

Fw 190D-9

eduard

GERMAN WWII FIGHTER

1/48 SCALE PLASTIC KIT

ProfiPACK
edition

#8184



INTRO

The fighter burden placed on the Fw 190A by the Luftwaffe was enormous. This very versatile aircraft found itself fulfilling fighter, fighter-bomber and ground support duties. Thanks to a robust airframe, the type was able to carry a wide variety of ordnance, which vastly improved upon the multi-role capabilities of the Luftwaffe's main fighter type, the Bf 109. Despite this, the design, which dated back to 1939, was finding its age showing towards the end of the war. The Fw 190A was falling short of its adversaries, especially at higher altitudes. The design development led first through the Fw 190B, powered by a BMW 801 with a turbo supercharger, followed by the Fw 190C, powered by an in-line DB 603, but was finalized on the Fw 190D. Conversion to the D version, and namely the Fw 190D-9, involved the installation of a new liquid cooled 12 cylinder Jumo 213A, rated at 1,726 hp. The front of the aircraft was therefore lengthened from the Fw 190A, which was fitted with a BMW 801 radial. In order to maintain the centre of gravity, there was a 50 cm extension at the rear of the plane, and a relocation of some of the interior components. The overall length of the Fw 190D-9, compared to the A-9, was increased by 1.52 m (just under five feet). The aircraft gained a new, more elegant shape, and was dubbed 'Langnasen Dora' ('Longnose Dora'). Other important changes in the type were the addition of MW 50 water methanol injection, temporarily boosting power output to 2,071 hp (1,545 kW), and increasing maximum speed to 680 km/h at 6600 m (426 mph at 21,650 ft). A standard feature on the D-9 was the bulged canopy, covering an armored head and back rest for the pilot. Despite this, the first series of the Fw 190D-9 were equipped with the older, flat style canopy. The armament was composed of two 13 mm MG 131 machine guns mounted over the engine, and two MG 151/20 20 mm cannon in the wing roots. The modifications through which the Fw 190D went through, were different enough to virtually consider it a new aircraft from the A, F and G. The first Fw 190D-9s were allocated to III./JG 54 in September 1944. This was followed by I./JG 26 in November and towards the end of the war there were 183 Doras in service. According to some sources, there over 1800 Fw 190Ds built. The D-9 led to other versions, of which only the D-11 and D-13 saw practical use. The more widely used D-11 (by some sources, the Luftwaffe took delivery of 17 pieces) differed from the D-9 first and foremost in armament, missing the 13 mm machine guns, but adding two outboard wing mounted 30 mm cannon, and by the installation of the upgraded Jumo 213E, along with other improvements. The armament of the D-11 was similar to the Fw 190A-8/R-2, which is indicative of the planned use of the type against Allied formations of heavy bombers. Out of over a thousand ordered D-13s, only seventeen were built, and only a handful reached combat units. The armament installation of the D-13 composed of two 20 mm cannon in the wing roots and one firing through the propeller hub. The D-13 also had all-weather flying equipment, along with other relatively modern avionics. Some later Doras were equipped with a larger tail unit („Einheitsheck“) standardized on the Ta 152. Volumes could (and have) be written covering the problematic subject of service camouflage schemes, which is quite varied and influenced by time and place of manufacture and the deteriorating conditions in Germany. The schemes consisted of RLM colors 70 and 80, as well as areas that remained in natural metal or fabric. Variations are also indicated in the scheme options in this kit. The longnose Dora was built mainly to adapt the proven Fw 190A to combat operations at high altitudes, above 7,000 m (20,000 ft), where allied bomber formations operated. Due to the development of events, these operational altitudes were rare. Even so, this was a fighter that could stand up to the best the Allies could field, and along with the Ta 152, represented the epitome of German piston-engined fighter design.

F W. Nr. 210003, Oblt. H. Dortenmann, I./JG 26, Germany, Spring 1945

On March 29th, 1945 Hans Dortenmann was appointed Staffelkapitän of 3./JG 26. In accordance to this, the marking of his Dora W.Nr. 210003 was changed from 'Black 1' to 'Yellow 1'. Also, the IV. Gruppe wave disappeared as I. Gruppe didn't use any special marking of this type. This is a reconstruction based on Dortenmann's memoirs. On the other hand, various sources say this Dora was used by JG 26 for a short period of time only at the end of WWII. There are doubts concerning the camouflage scheme changes also, as it is possible that this Dora W.Nr. 210003 wore the original RLM 74/75 pattern throughout its whole life. The camouflage changes as described by Dortenmann were done during major repairs only. In such a case, the original colours would have been completely stripped down and replaced with new ones.

FOR COMPLETE PROFILE PLEASE REFER
www.eduard.com

ČESKOU VERZI TEXTU A KOMPLETNÍ
KAMUFLÁŽNÍ SCHÉMA NALEZNETE NA
www.eduard.cz
POD KATALOGOVÝM ČÍSLEM 8184

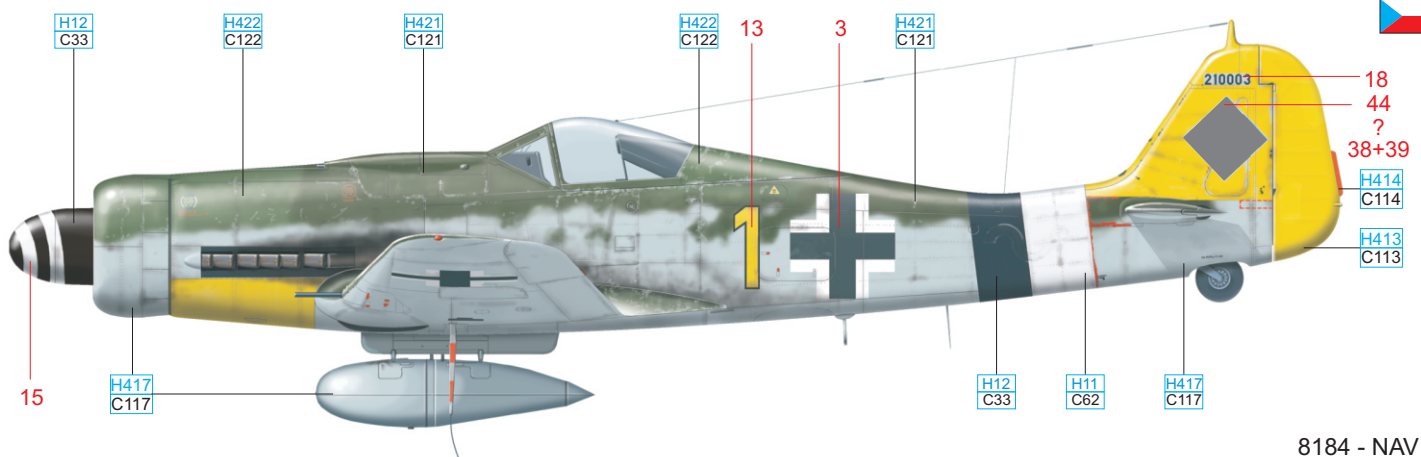

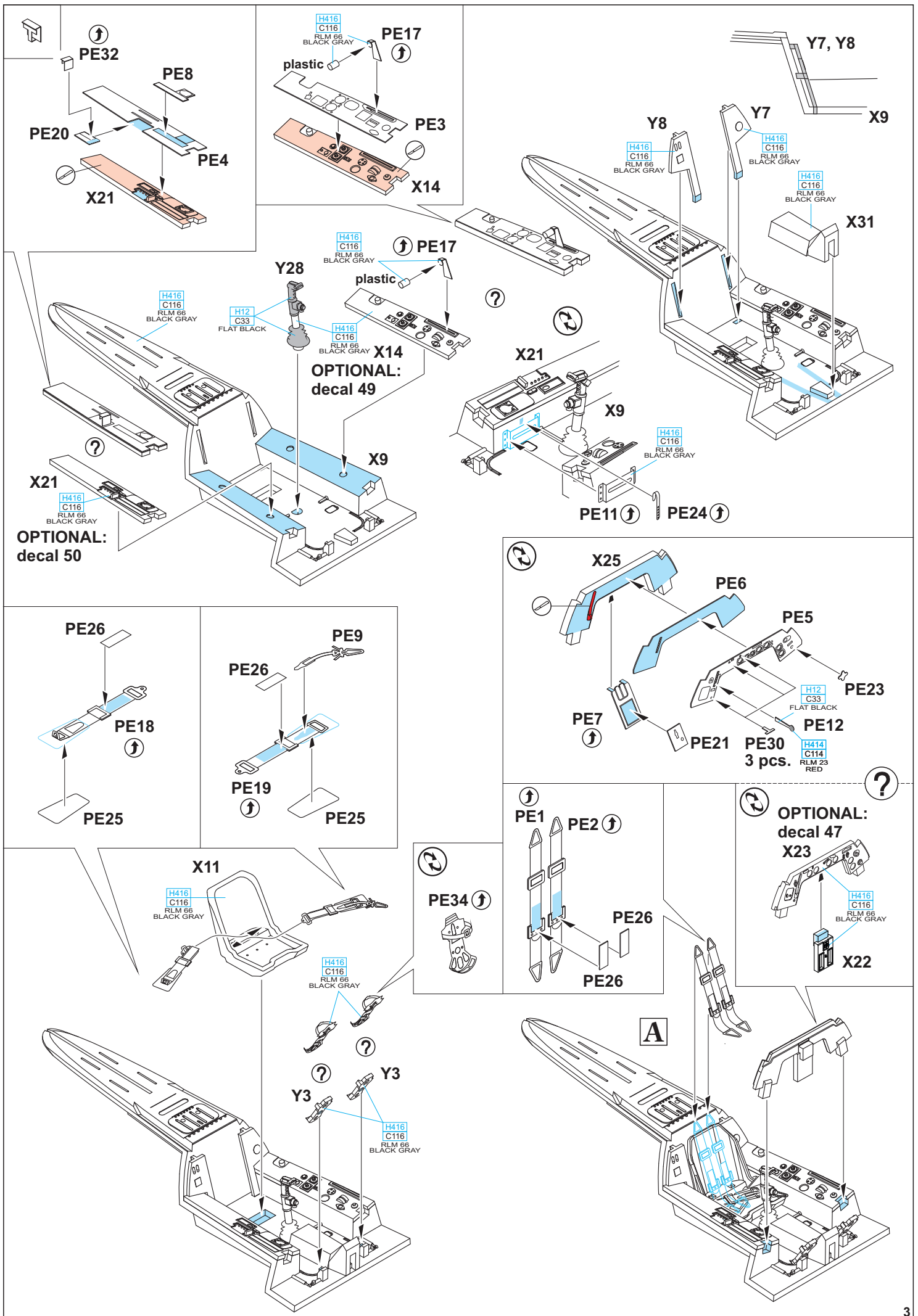



Carefully read instruction sheet before assembling. When you use glue or paint, do not use near open flame and use in well ventilated room. Keep out of reach of small children. Children must not be allowed to suck any part, or pull vinyl bag over the head.



Před započítím stavby si pečlivě prostudujte stavební návod. Při používání barev a lepidla pracujte v dobře větrané místnosti. Lepidla ani barvy nepoužívejte v blízkosti otevřeného ohně. Model není určen malým dětem, mohlo by dojít k požití drobných dílů.

INSTRUCTION SIGNS

* INSTR. SYMBOLS

* INSTRUKTION SINNBILDEN

* SYMBOLES

* 記号の説明



OPTIONAL
VOLBA



BEND
OHNOU



OPEN HOLE
VYVRTAT OTVOR



SYMMETRICAL ASSEMBLY
SYMETRICKÁ MONTÁŽ



REMOVE
ODŘÍZNOUT



REVERSE SIDE
OTOČIT



APPLY EDUARD MASK
AND PAINT
POUŽÍT EDUARD MASK
NABARVIT

PARTS



DÍLY



TEILE



PIÈCES



部品

PLASTIC PARTS

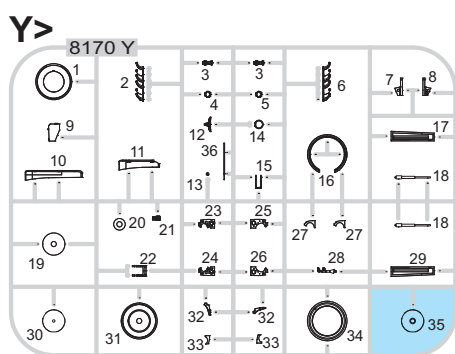
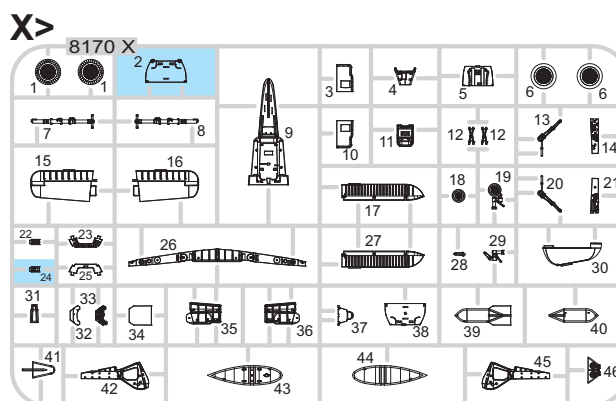
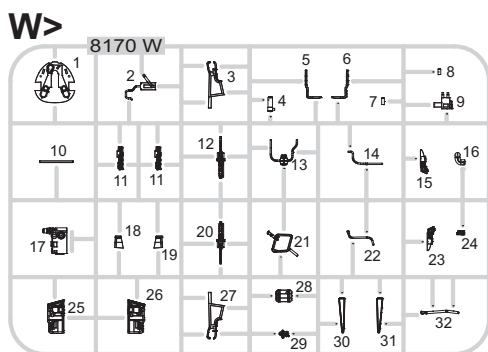
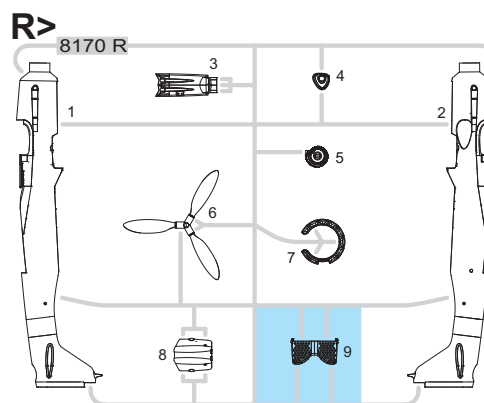
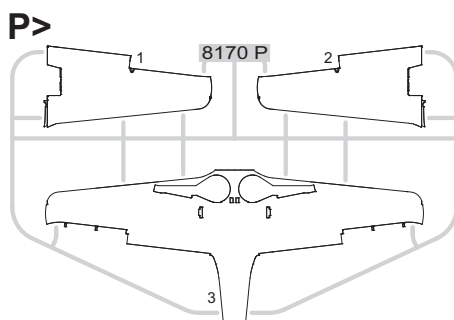
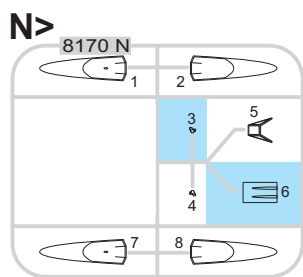
PE - PHOTO ETCHED
DETAIL PARTS

-Parts not for use. -Teile werden nicht verwendet. -Pièces à ne pas utiliser. -Tyto díly nepoužívejte při stavbě. - 使用しない部品

COLOURS



BARVY



FARBEN



PEINTURE



色

GSI Creos (GUNZE)		
AQUEOUS	Mr.COLOR	
H2	C2	BLACK
H8	C8	SILVER
H11	C62	FLAT WHITE
H12	C33	FLAT BLACK
H33	C81	RUSSET
H47	C41	RED BROWN
H69	C37	RLM75 GRAY
H70	C60	RLM02 GRAY
H77	C137	TIRE BLACK
H80	C54	KHAKI GREEN
H413	C113	RLM04 YELLOW

AQUEOUS	Mr.COLOR	
H414	C114	RLM23 RED
H416	C116	RLM66 BLACK GRAY
H417	C117	RLM76 LIGHT BLUE
H421	C121	RLM81 BROWN VIOLET
H422	C122	RLM82 LIGHT GREEN
Mr.METAL COLOR		
	MC214	DARK IRON
	MC218	ALUMINIUM
Mr.COLOR SUPER METALLIC		
	SM01	SUPER FINE SILVER
	SM04	STAINLESS

**DON'T INSTALL PARTS W12, W20, W3 AND W27 IF YOU ARE BUILDING THE MODEL WITH THE CLOSED FUSELAGE MG HOOD (R8).
POKUD STAVÍTE MODEL SE ZAVŘENÝM KRYTEM TRUPOVÝCH KULOMETŮ (R8), NEINSTALUJTE DÍLY W12, W20, W3 A W27**

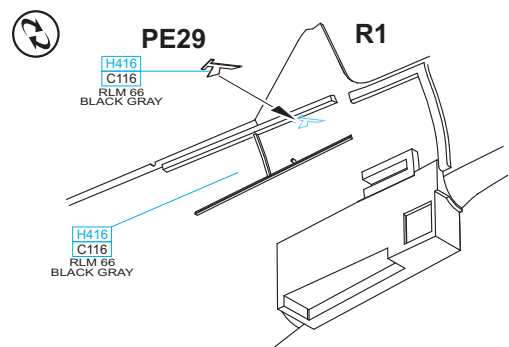
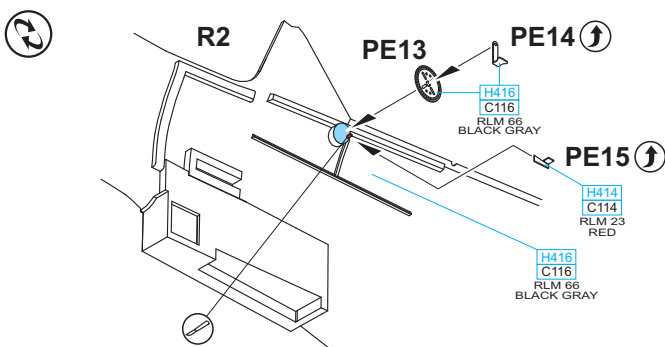
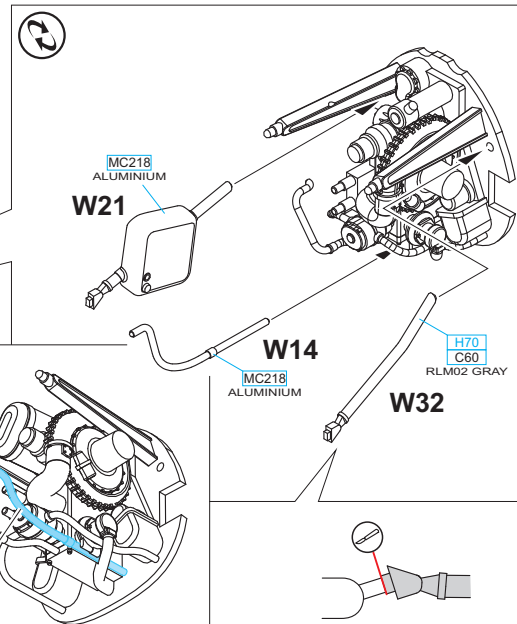
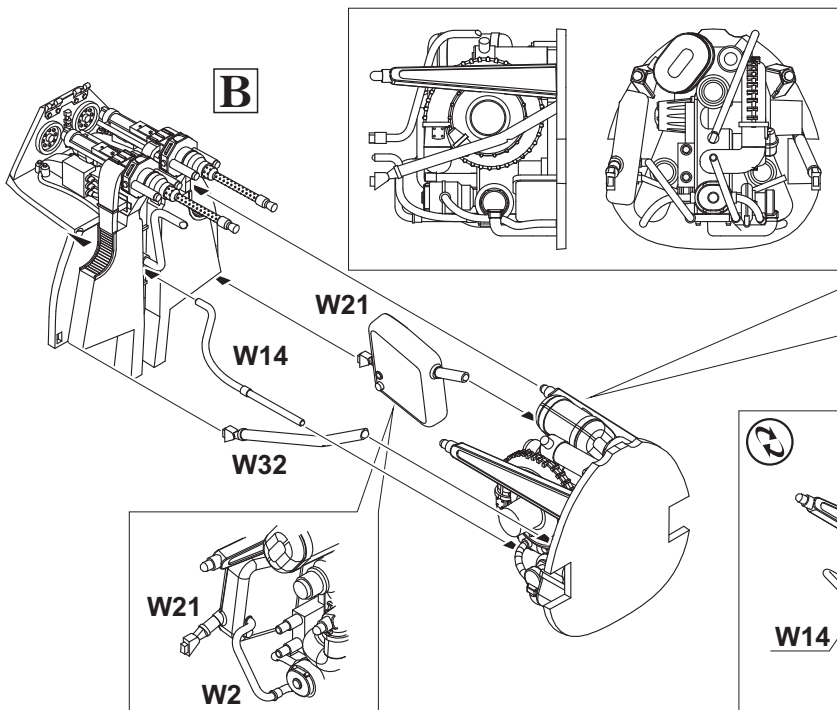
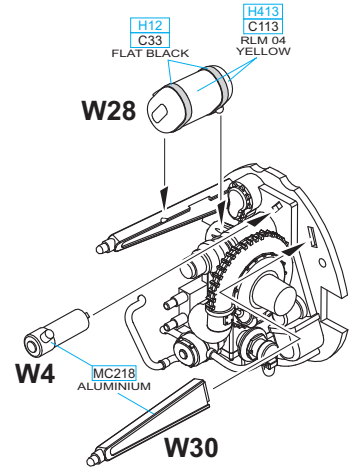
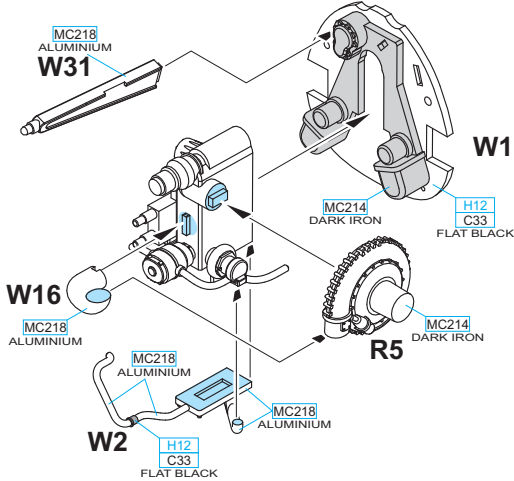
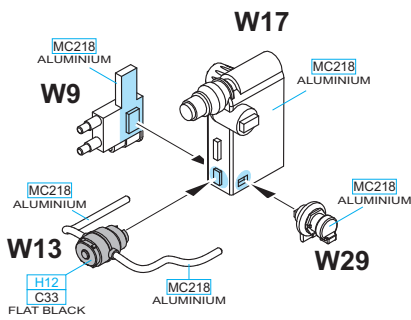
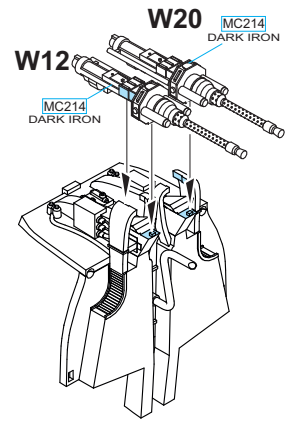
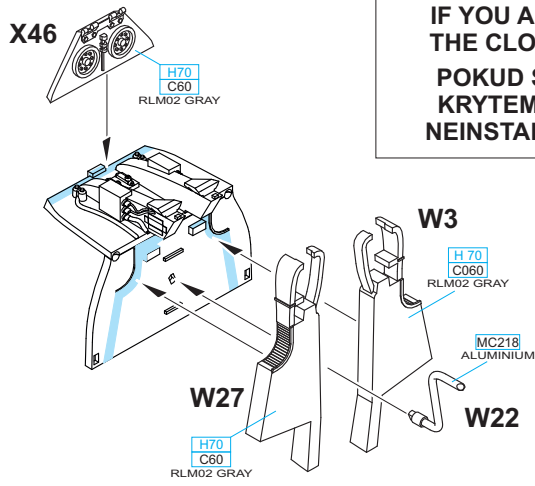
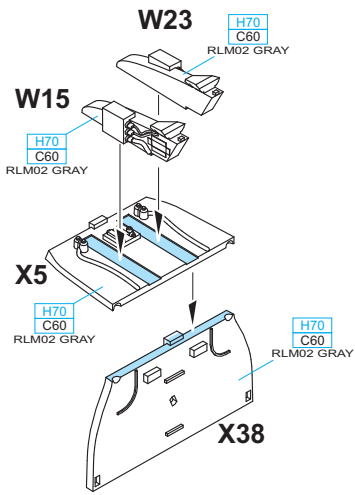

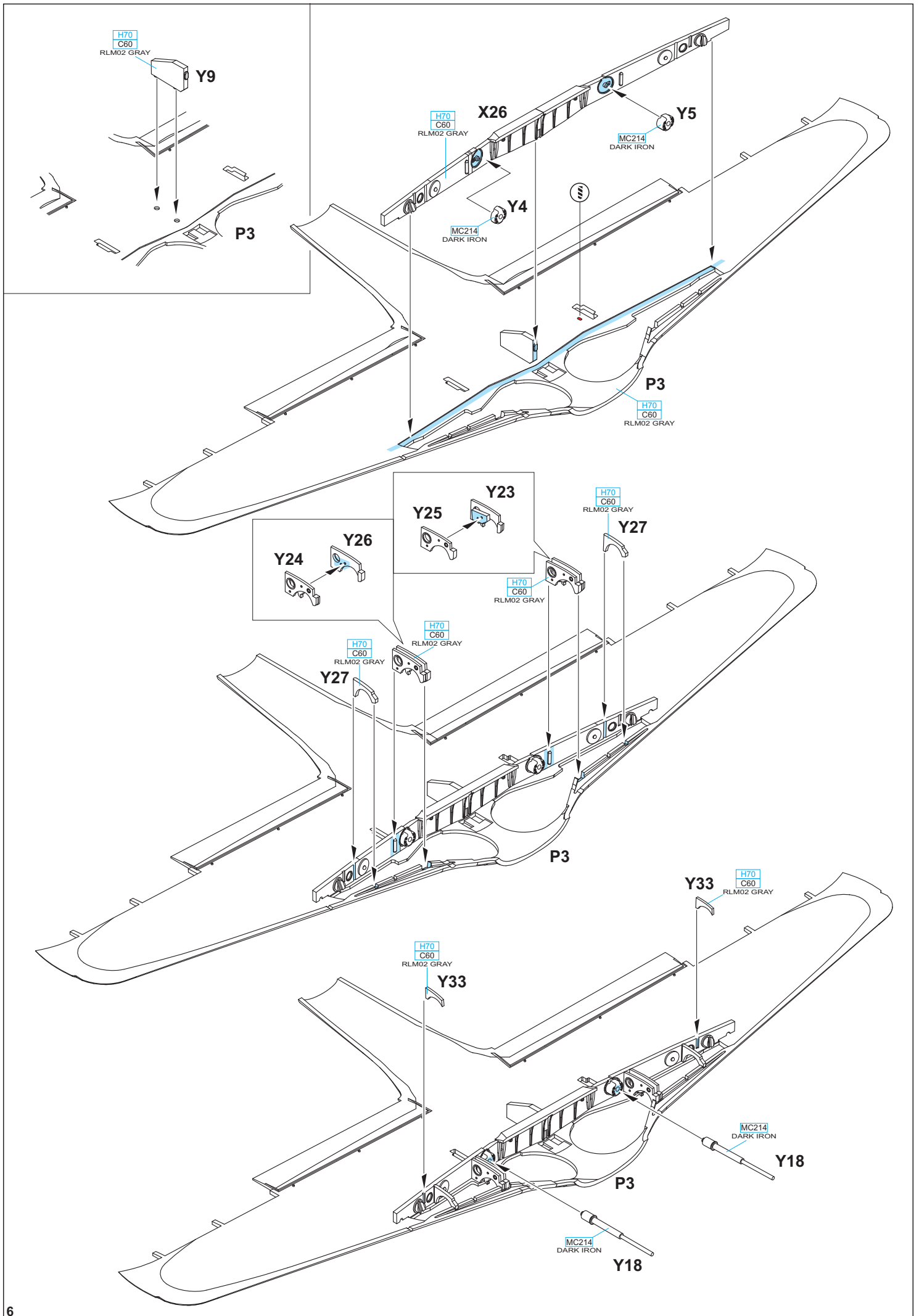

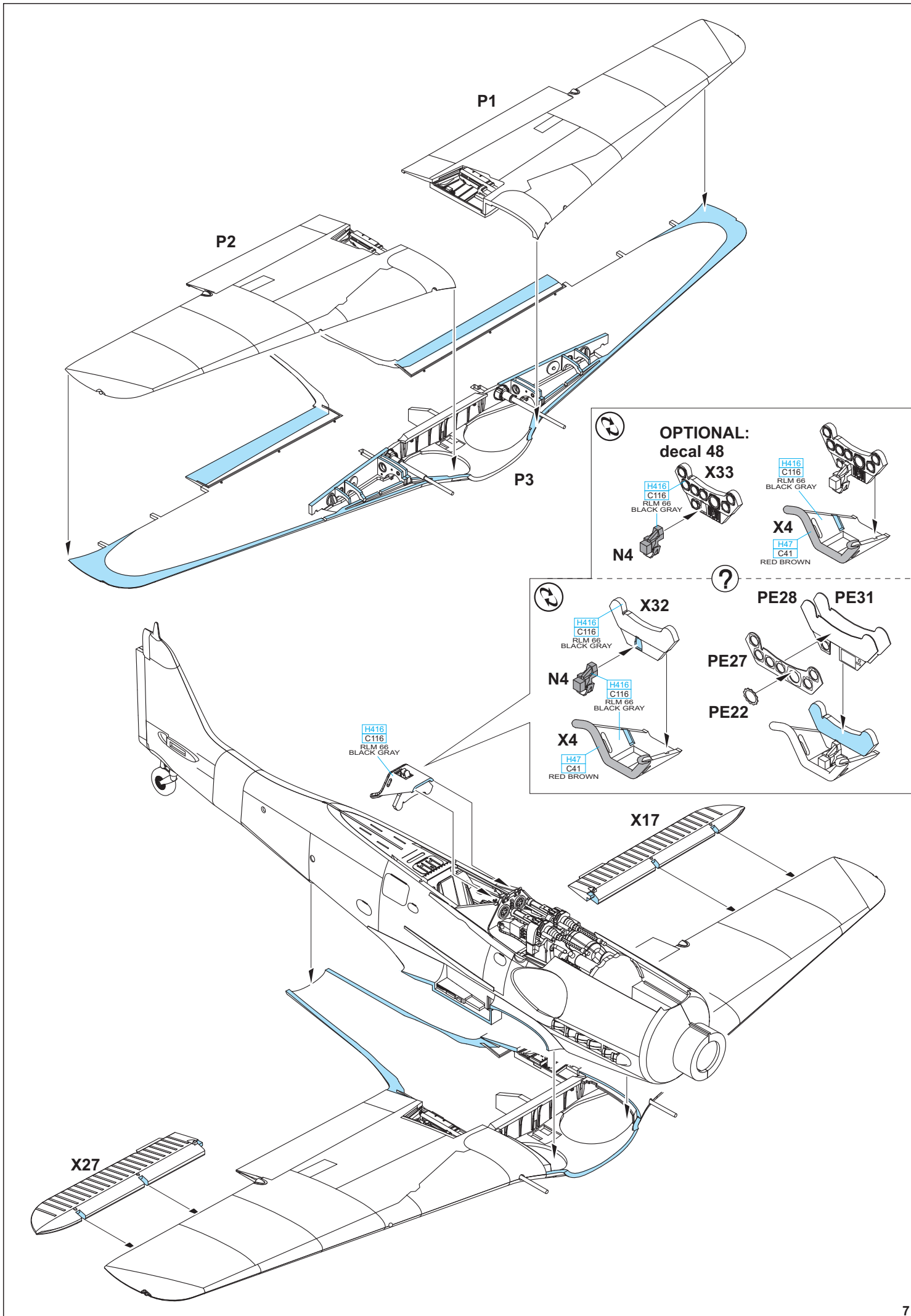

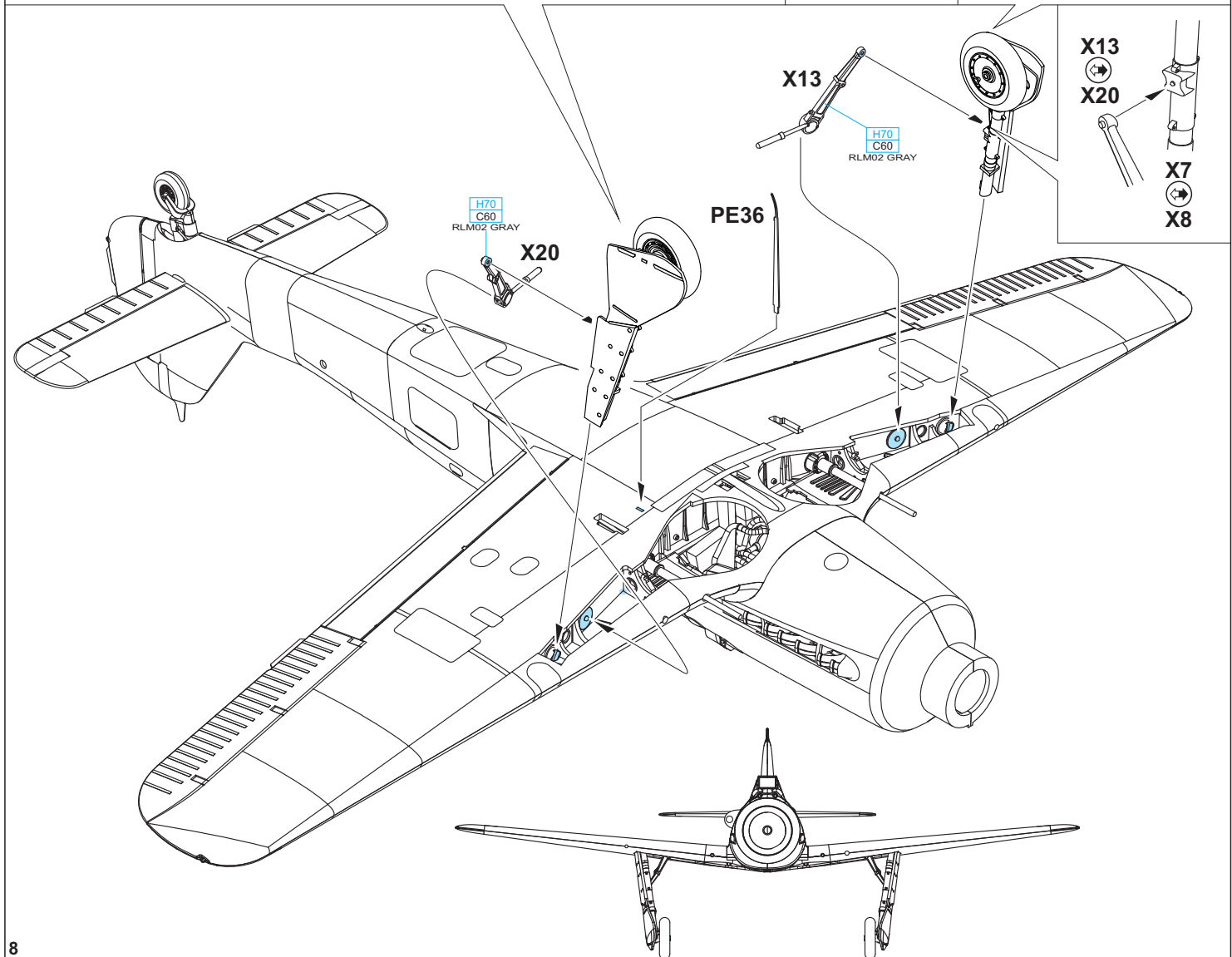
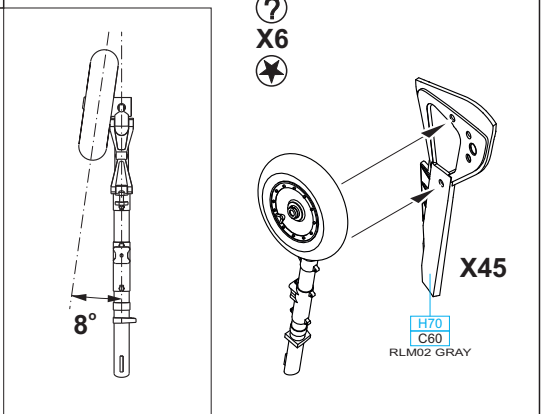
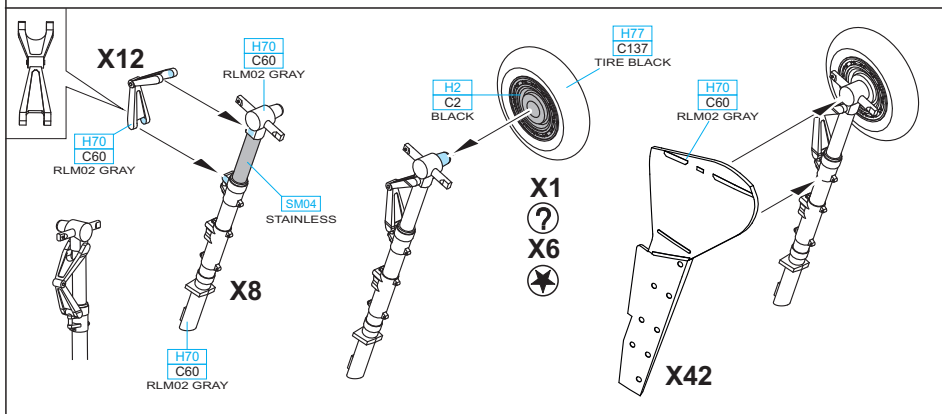
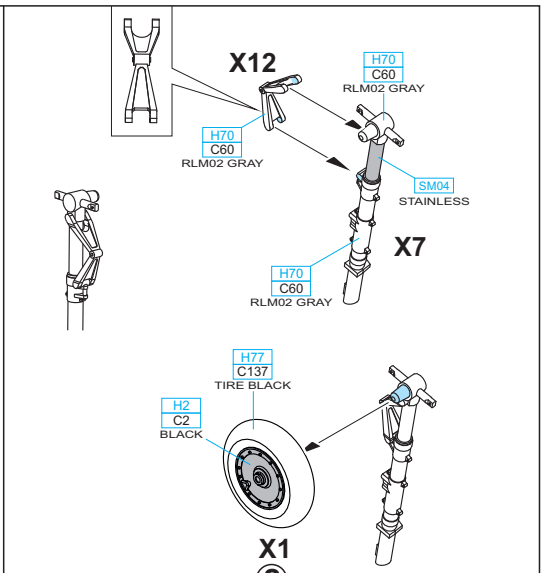
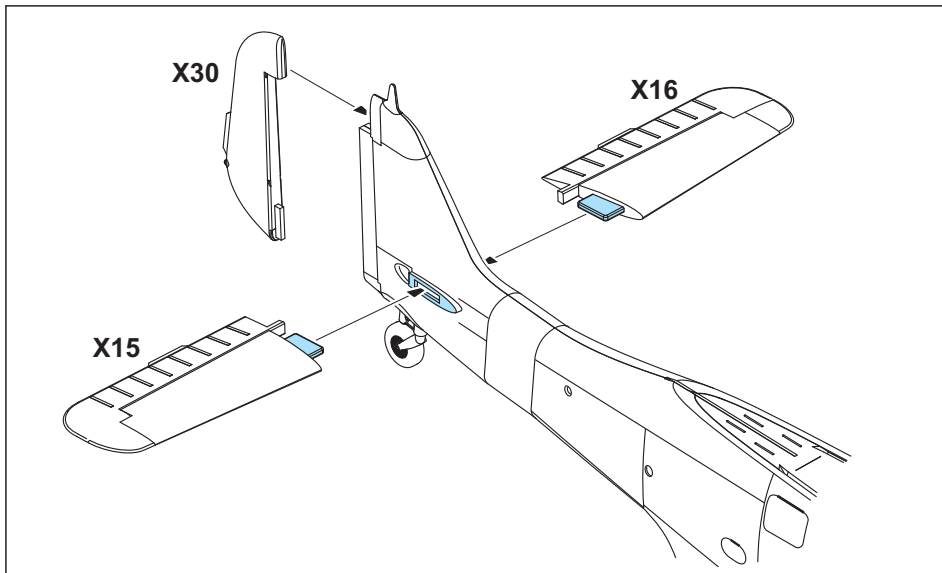

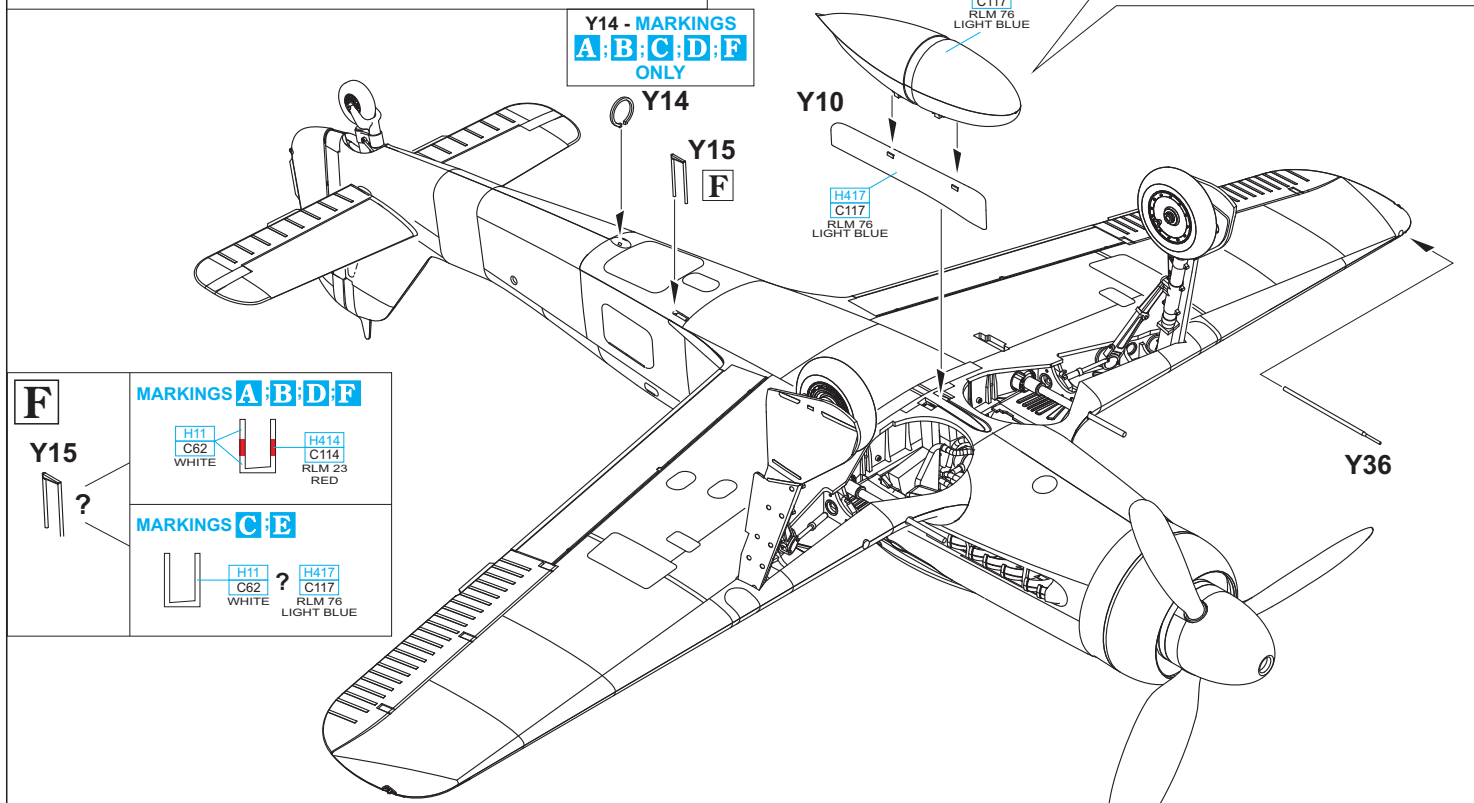
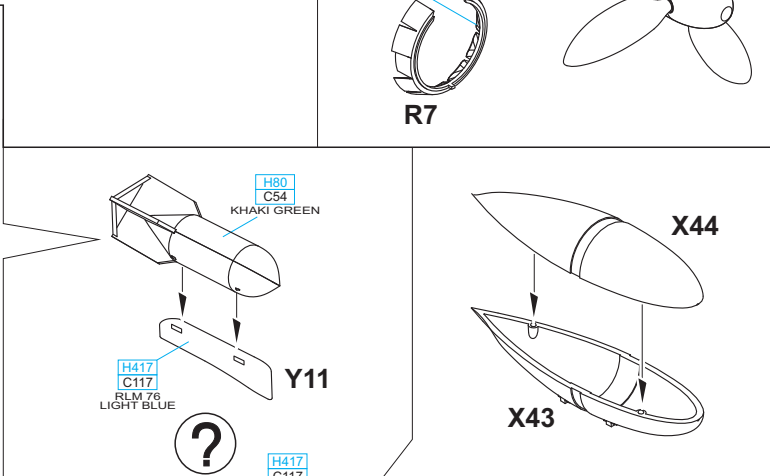
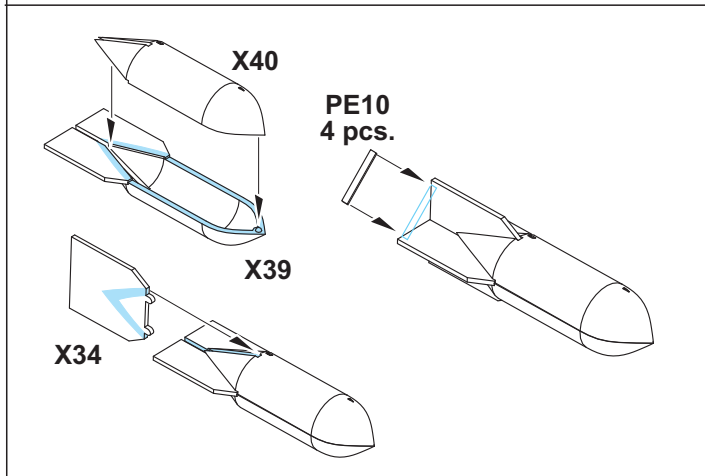
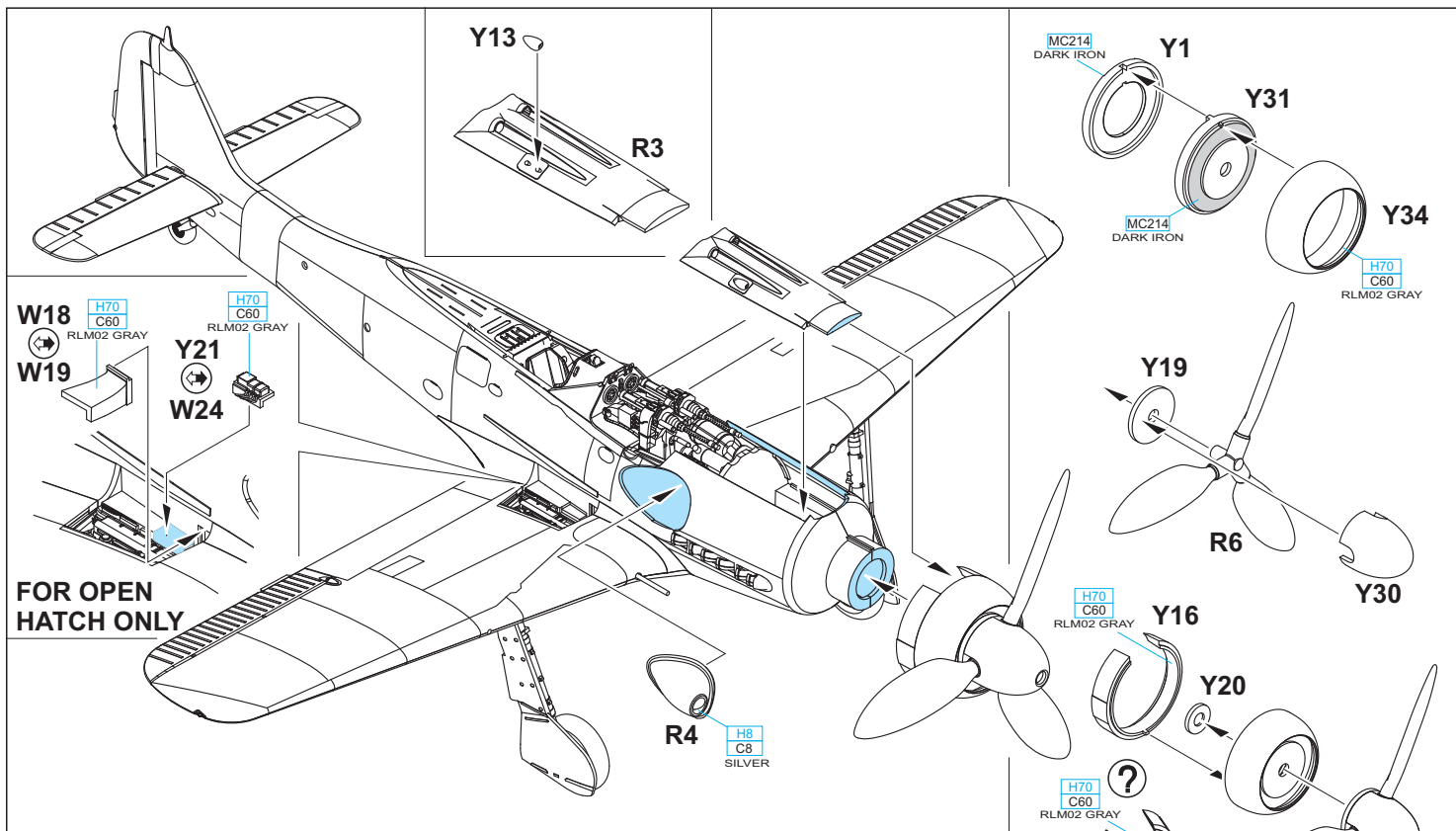

MARKINGS A, B, F

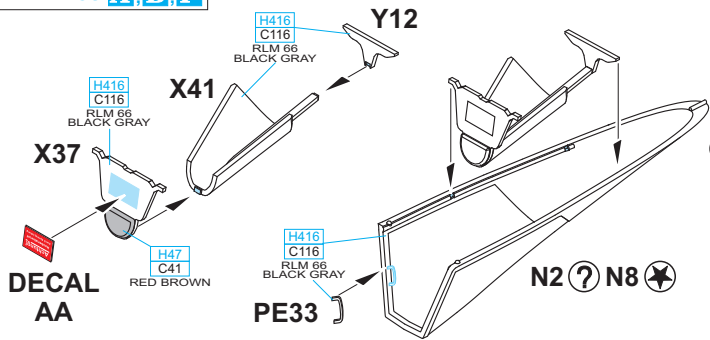

N2 - OPEN CANOPY N8 - CLOSED CANOPY

MARKINGS C, D, E

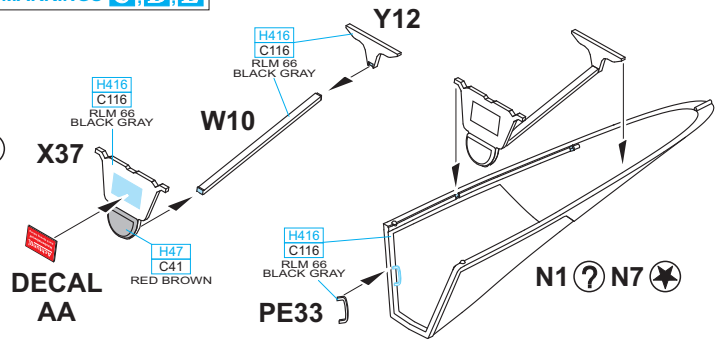

N1 - OPEN CANOPY N7 - CLOSED CANOPY

MARKING A

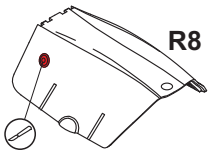

MARKINGS B, F

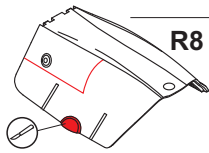

ADD PANEL LINE ON BOTH SIDES

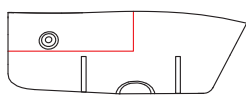

MARKING C

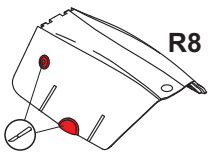

MARKINGS D, E

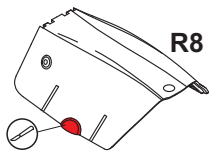

CLOSED HOOD

Y22

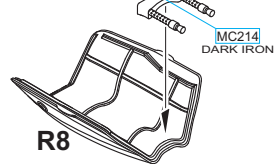

CLOSED X36



CLOSED HATCH ONLY

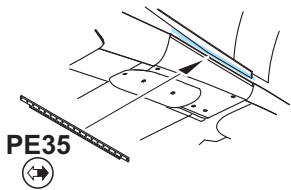

CLOSED X35

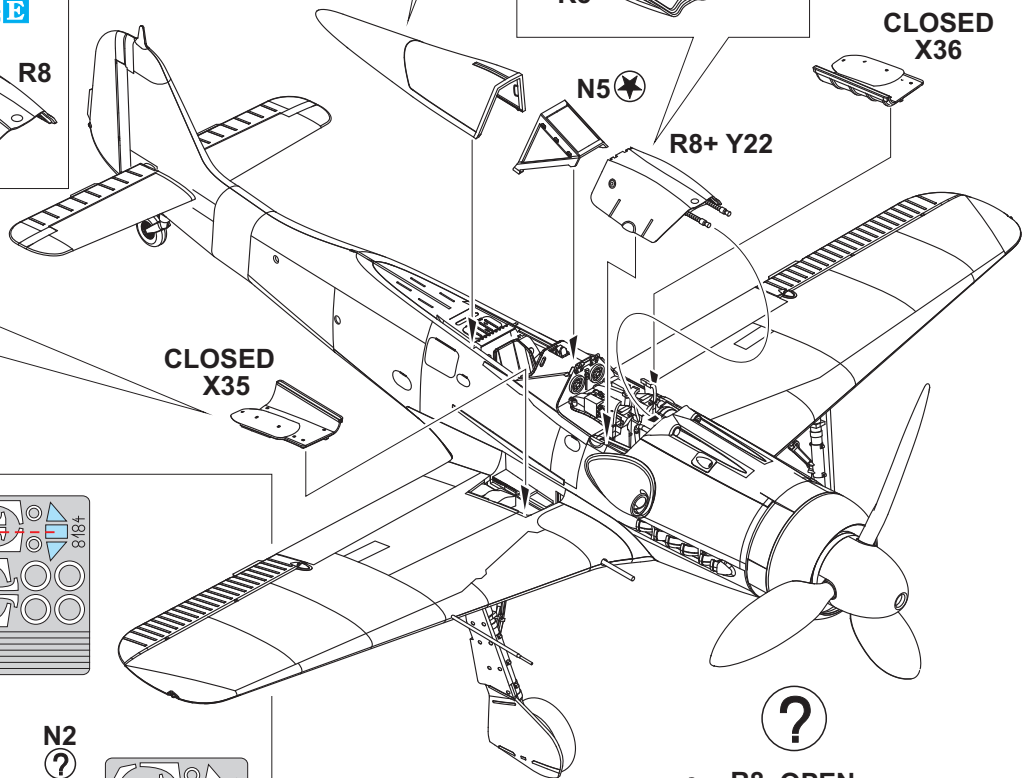
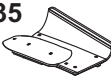

eduard MASK

X1 ?
X6



N5



X18



N2 ?
N8

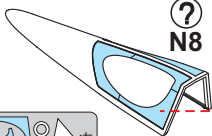

N1 ?
N7

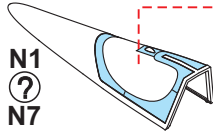

METAL COLOR

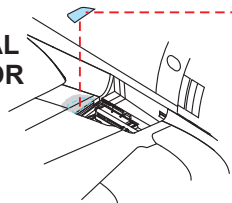

CAMOUFLAGE COLOR

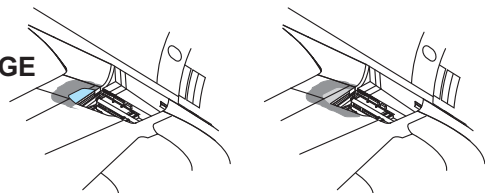

?

R8 OPEN

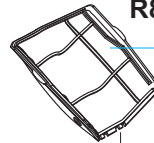

H70 C60 RLM02 GRAY

X35 OPEN



X36 OPEN

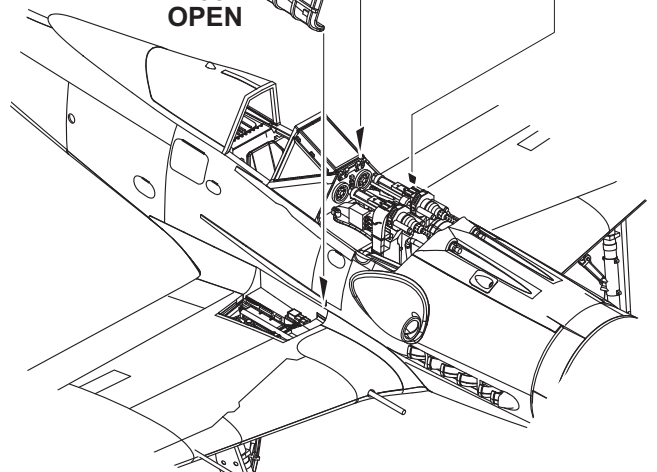
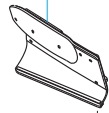

A W. Nr. 500408, 5./JG 301, Bad Langensalza, Germany, May 1945

This Dora, W.Nr. 500408, was discovered by U.S. forces at the airport near Bad Langensalza. She was one of seventy aircraft of Mimetall's second production batch, produced between December 1944 and January 1945. The yellow-red tail band indicates that this aircraft belonged to JG 301, the red horizontal bar denotes use by II. Gruppe, and the white individual numbers denote 5. Staffel aircraft. The fuselage was camouflaged in an RLM 81 and 82 pattern. Wing upper surfaces were in RLM 81 and 82. The forward part of the wing under surfaces were RLM 81. Note two variations of the RLM 76 color. The camouflage of the aileron undersurfaces indicate field replacement.

ČESKOU VERZI TEXTU NALEZNETE NA
www.eduard.cz
 POD KATALOGOVÝM ČÍSLEM 8184

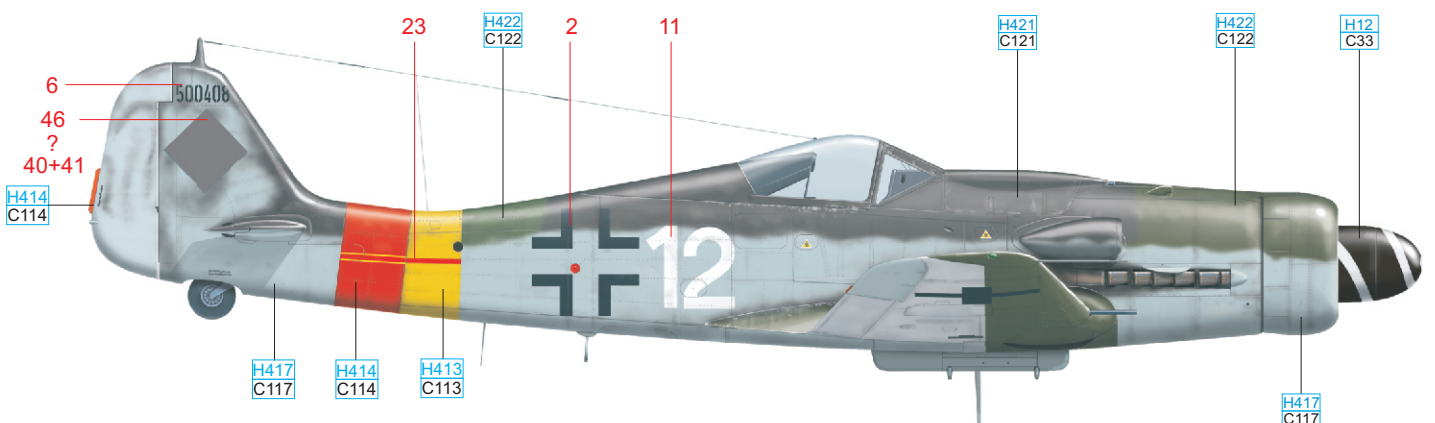
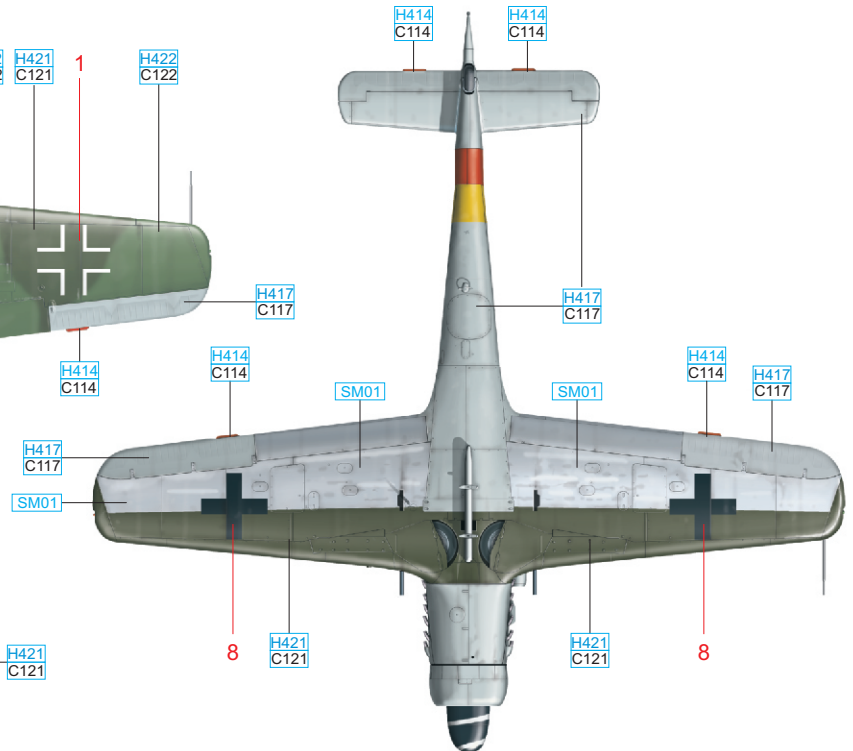
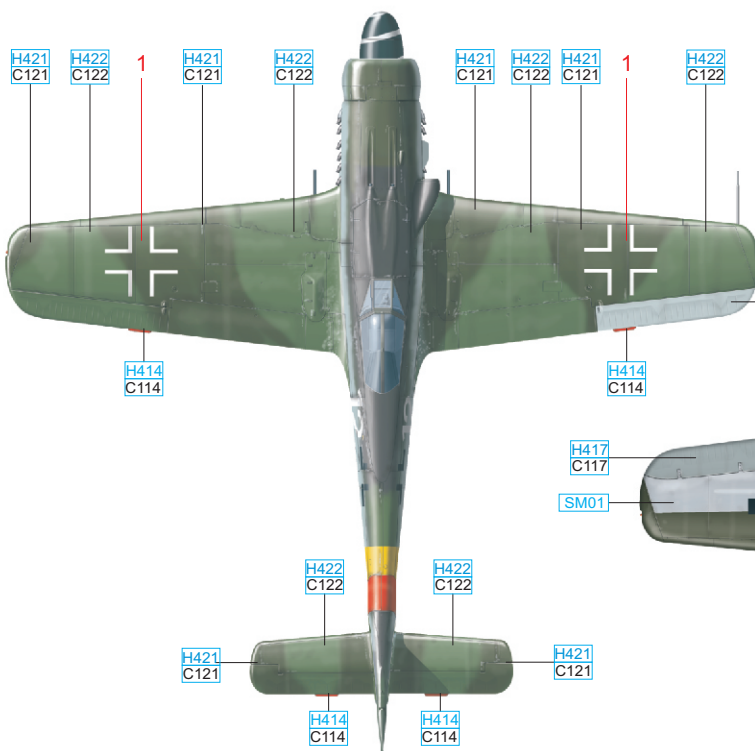
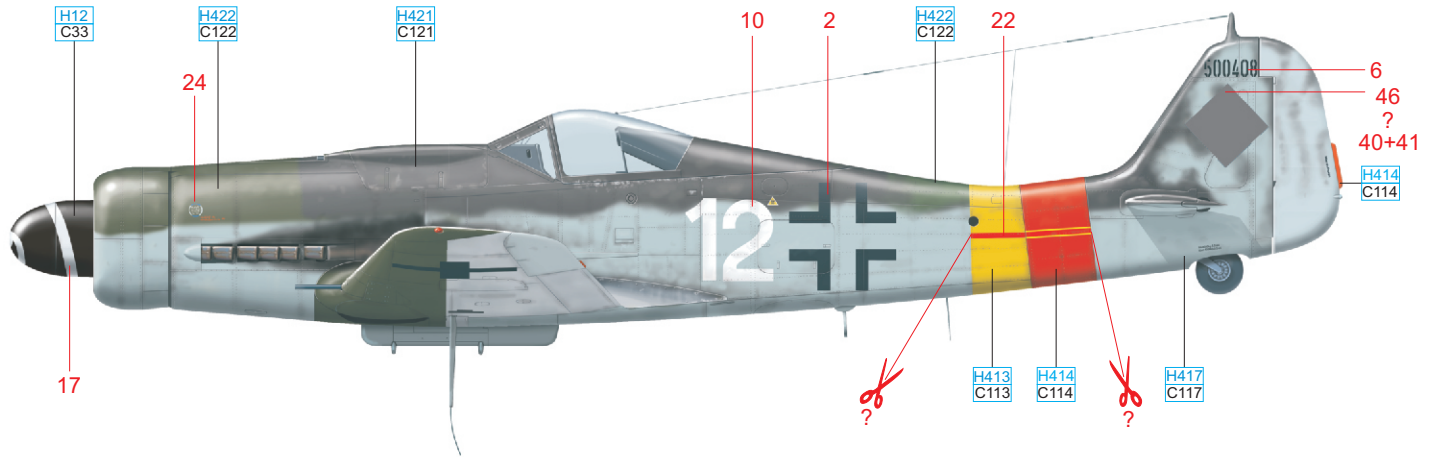

RLM 04	H413 C113	RLM 23	H414 C114	ALUMINIUM	SM01
RLM 76	H417 C117	RLM 81	H421 C121	RLM 82	H422 C122
				BLACK	H12 C33

B W. Nr. 210003, Oblt. H. Dortenmann, IV./JG 26, Germany, 1945

Oblt. Hans Dortenmann, a 38 kill fighter ace and Knight's Cross holder, noted in his memoirs that he used Dora W.Nr. 210003 as a personal mount from September 1944 to the end of hostilities. He personally destroyed her at the end of hostilities to avoid falling into enemy hands. At first, during Dortenmann's service with III./JG 54, the airplane was marked 'Red 1'. In late February III./JG 54 was redesignated IV./JG 26, and Dortenmann was appointed Staffelkapitän of 12./JG 26. His Dora became 'Black 1'. The White-Black band appeared on the tail as well as IV. Gruppe's wave. According to Dortenmann's memoirs, the original RLM 74/75 camouflage scheme was changed to RLM 81/82, but the reason for re-painting remains unknown. A new-style blown canopy was installed instead of the original flat one. The vertical part of the tail unit was painted yellow from JG 54 days.

ČESKOU VERZI TEXTU NALEZNETE NA
www.eduard.cz
 POD KATALOGOVÝM ČÍSLEM 8184

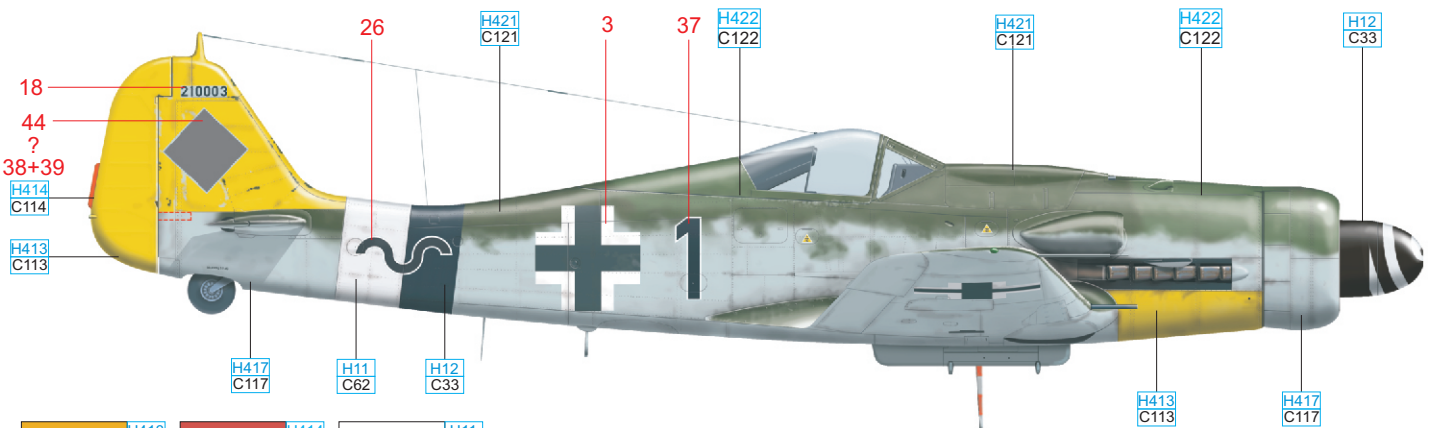
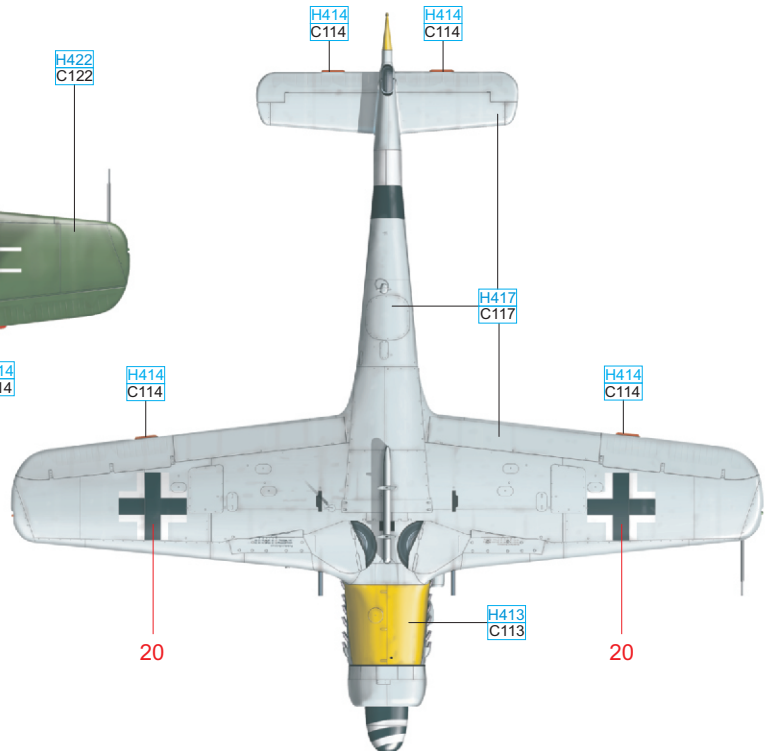
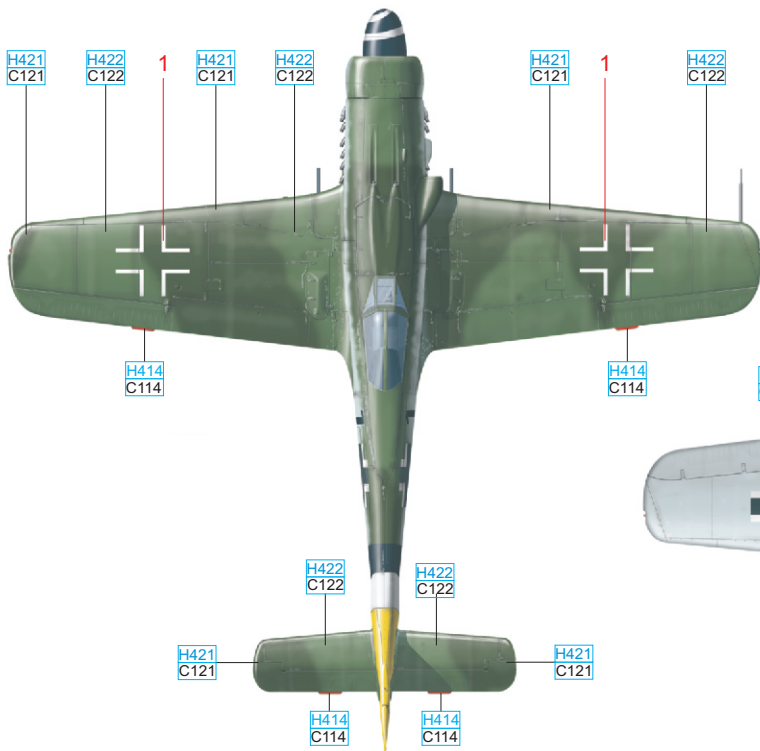
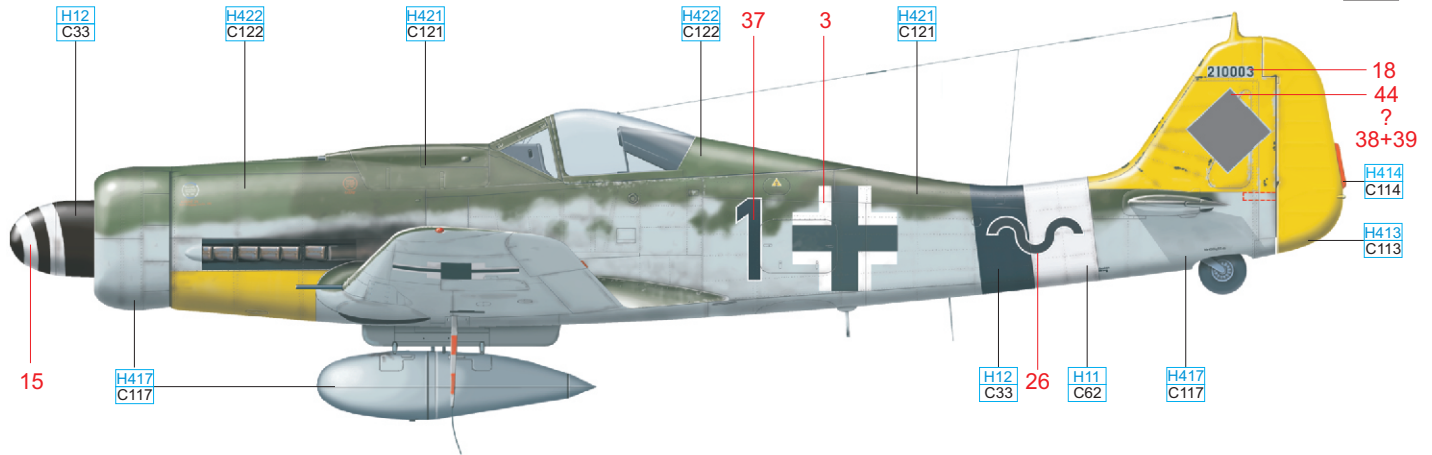

RLM 04	H413 C113	RLM 23	H414 C114	WHITE	H11 C62
RLM 76	H417 C117	RLM 81	H421 C121	RLM 82	H422 C122
		BLACK	H12 C33		

C W. Nr. 600150, Stab/JG 4, Frankfurt am Rhein-Main, Germany, April 1945

Dora W.Nr. 600150 was built by Gerhard Fieseler Werke (first production batch). It is the only recently discovered JG 4 Dora that sports the unit's badge. U.S. forces found her at Frankfurt am Rhein-Main airfield in April, 1945. Camouflage consisted of RLM 74/75 on the upper surfaces, and blue-green RLM 76 on the lower. The RLM 74 and 75 were applied to the fuselage, and the tail unit wore mottling of the same colours. The engine section showed original Junkers paint of RLM 74 and a whitish RLM 76. The RLM 75 spots were added to the upper cowling by GFW. The forward part of the wing under surfaces, ailerons and landing flaps were blue-green RLM 76. The Werk Nummer is present on the port side of the fin only. There is no pulley system on the early-style canopy. The Black-White-Black band on the tail identifies this as a JG 4 aircraft.

ČESKOU VERZI TEXTU NALEZNETE NA
www.eduard.cz
 POD KATALOGOVÝM ČÍSLEM 8184

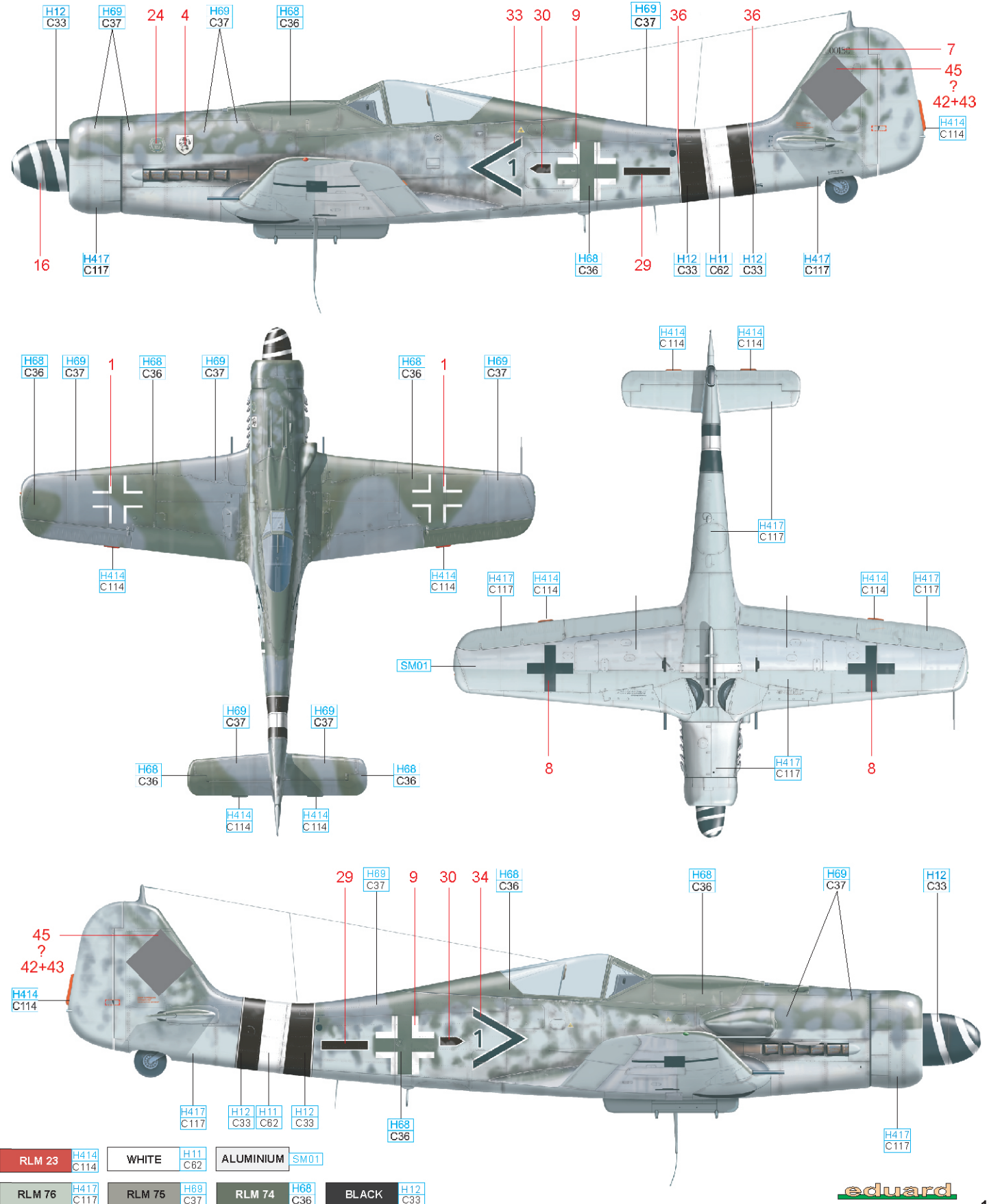

RLM 23	H414 C114	WHITE	H11 C62	ALUMINIUM	SM01
RLM 76	H417 C117	RLM 75	H69 C37	RLM 74	H68 C36
				BLACK	H12 C33

D W. Nr. 211115, I./EKG(J) or V./EJG 2, Pilsen, Czechoslovakia, May 1945

Dora captured by U.S. forces at Pilsen airfield in May, 1945, formerly belonged to I./EKG(J) – I. Gruppe of Ergänzungskampfgeschwader (Jagd). This supplementary unit was redesignated as V./EJG 2 on March 29th, 1945, and was located in Pilsen by the end of hostilities. Unusual style of Gruppe wave in red indicates that this Dora belonged to V./EJG 2 rather than to I./EKG(J) as this Gruppe marking wasn't used by I. Gruppe. The upper surfaces were camouflaged in RLM 81/82, and the under surfaces in RLM 76. The forward part of wing under surfaces were RLM 81, while the remainder of the wing bottoms were left unpainted except for the RLM 76 ailerons. The small black circle with a stylized number 17 under the cockpit appeared on the aircraft after capture and its exact meaning is unknown.

ČESKOU VERZI TEXTU NALEZNETE NA
www.eduard.cz
 POD KATALOGOVÝM ČÍSLEM 8184

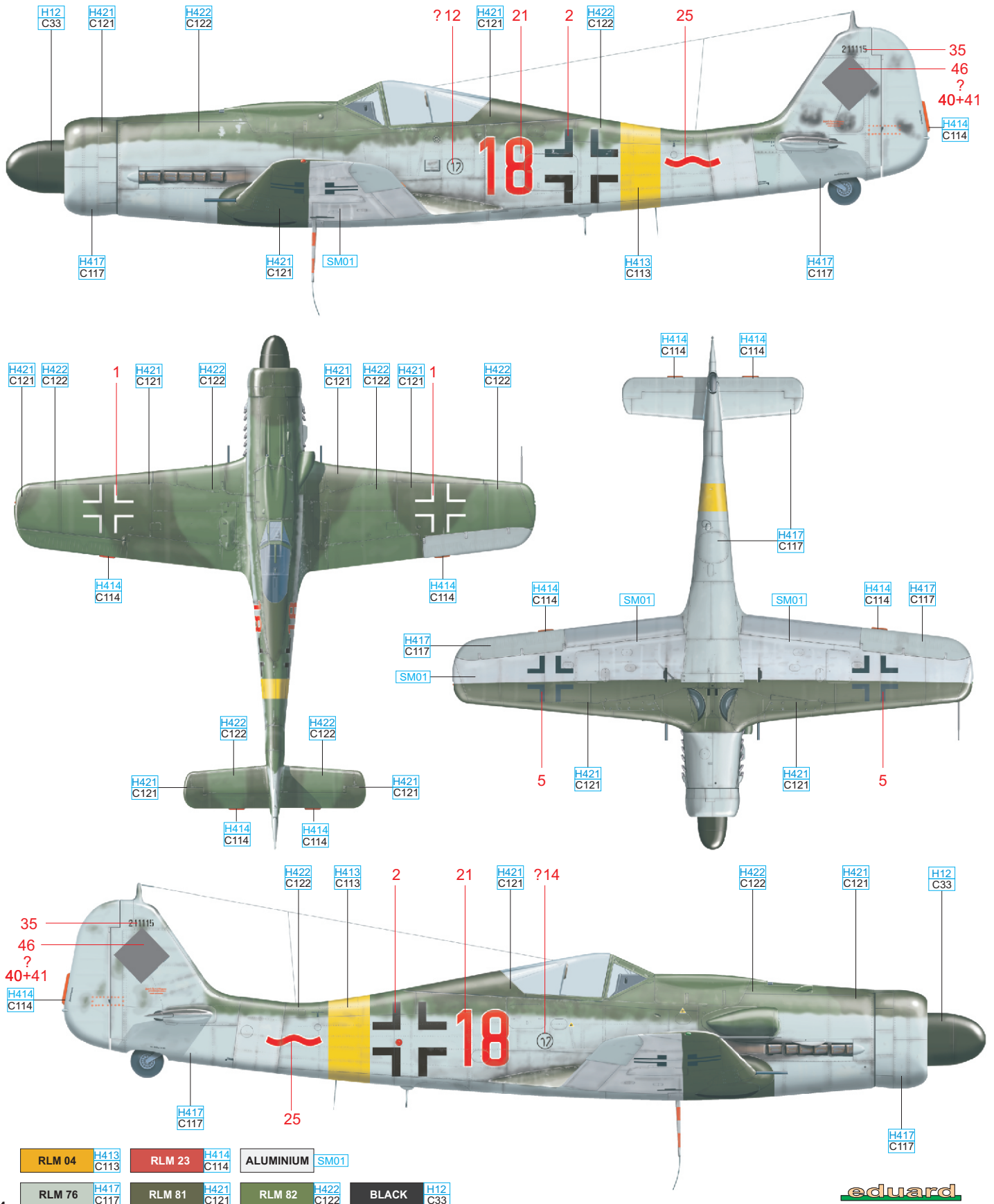

RLM 04	H413 C113	RLM 23	H414 C114	ALUMINIUM	SM01
RLM 76	H417 C117	RLM 81	H421 C121	RLM 82	H422 C122
				BLACK	H12 C33

E W. Nr. 211164, Stab/JG 6, Prag – Rusin, Czechoslovakia, May 1945

Dora W.Nr. 211164 found at Prague-Rusin airfield after WWII, in all probability belonged to Stab/JG 6. The upper cowling was painted in RLM 81 as well as the rest of the fuselage except for the rear, which was sprayed RLM 82. The tail section had previously been painted with a light colored tailband, which was oversprayed with RLM 81. The same colour was used for spots sprayed on the vertical tail surface. Wing upper surfaces were in RLM 81/ 82 too. The forward part of the wing undersides were painted RLM 81. Note the lack of a white spiral on the propeller spinner that was prescribed for all fighter aircraft engaged in the Western theatre of operations from July 1944 onwards.

ČESKOU VERZI TEXTU NALEZNETE NA
www.eduard.cz
 POD KATALOGOVÝM ČÍSLEM 8184

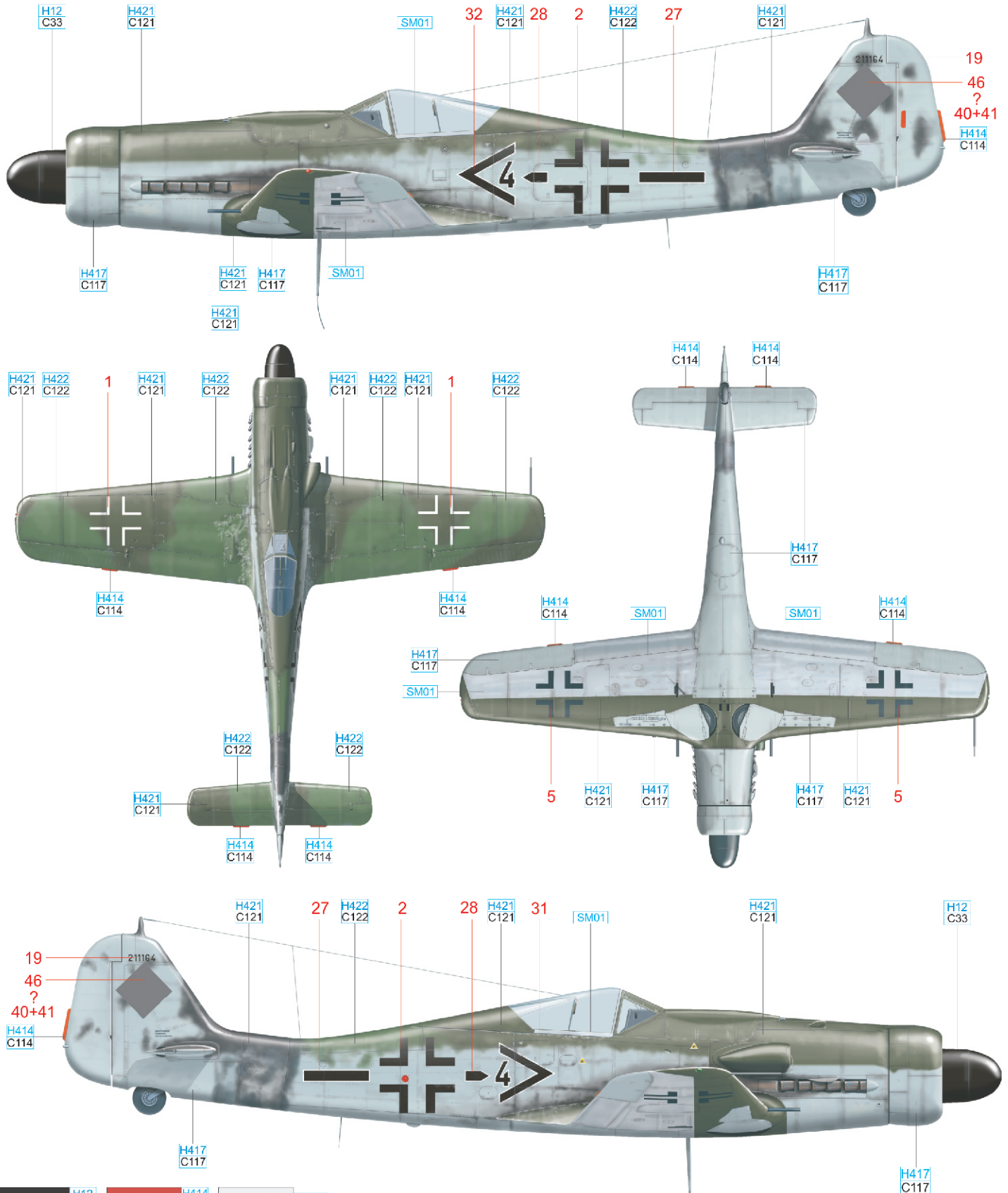

BLACK	H12 C33	RLM 23	H414 C114	ALUMINIUM	SM01
RLM 76	H417 C117	RLM 81	H421 C121	RLM 82	H422 C122

