

## 1/48 SCALE PLASTIC KIT

**ProfiPACK**  
edition

# #8197



### INTRO

The French SPAD XIII was a development of the SPAD VII. The SPAD VII was flown by Georges Guynemer, who was not particularly pleased with the type, especially when compared to the aircraft flown by his German adversaries. He took his concerns directly to the manufacturer. Because by this time, Guynemer was already well known in French life in general, his concerns were taken seriously. With that, the groundwork for the development of two more models were laid, the SPAD XII and SPAD XIII. While the SPAD XII was armed with a 37 mm cannon, and as such saw limited production and use by very experienced pilots, the SPAD XIII saw much more widespread use.

Thanks to the use of a more powerful Hispano-Suiza HS 8Be engine rated at 220 hp, and later the HS 8BEe (235 hp), the main drawback of the previous model in the form of inadequate armament could be addressed, and the SPAD XIII received two Vickers machine guns with 400 rpg. The head designer of the type, Louis Bechereau also enlarged the airframe slightly, and strengthened it. The first prototype of the SPAD XIII was flown by Second Lieutenant Rene Dorme on April 4th, 1917.

Due to a heavier weight, the new type didn't achieve the maneuverability of its predecessor, but it did display a better rate of climb, and a faster speed of 215 km/h.

The performance of the new type was such that contracts were immediately awarded for large production numbers. This was ultimately participated in by nine manufacturers (SPAD, A.C.M., Bernard, Bleriot, Borel, Kellner, Levasseur, Nieuport, and SAFCA). The new type began reaching units during the summer of 1917. The type was flown by a list of well-known and successful pilots - Frenchman Rene Fonck (75 kills), Italian Francesco Baracca (34 kills), Americans Eddie Rickenbacker (26 victories), Frank Luke (18 kills) and the aforementioned Georges Guynemer. Besides the French air force, the SPAD XIII was also flown by Great Britain, USA, Italy, Belgium, and, after the First World War, with Poland and the former Czechoslovakia.

Originally, the aircraft had rounded wingtips, but these soon reverted back to the squared off tips of the SPAD VII. This kit is dedicated to aircraft of the initial production phase.

**E** flown by Lt. E. Maurice Jean-Paul Boyau, Escadrille No. 77,  
Manoncourt-en-Vermois, France, March 1918

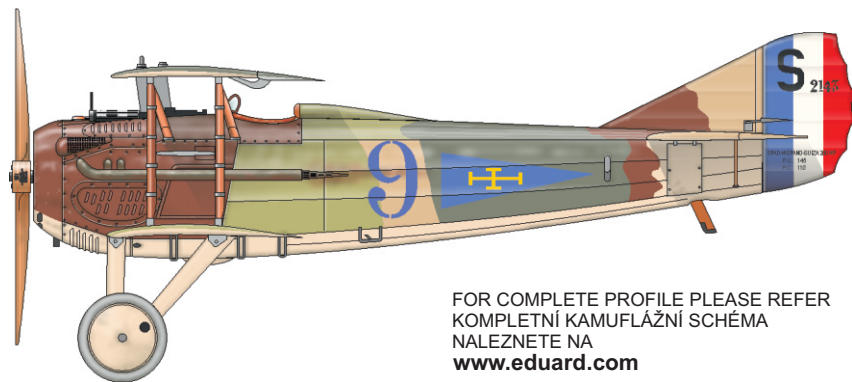

FOR COMPLETE PROFILE PLEASE REFER  
KOMPLETNÍ KAMUFLÁŽNÍ SCHEMA  
NALEZNETE NA  
[www.eduard.com](http://www.eduard.com)



Carefully read instruction sheet before assembling. When you use glue or paint, do not use near open flame and use in well ventilated room. Keep out of reach of small children. Children must not be allowed to suck any part, or pull vinyl bag over the head.



Před započítím stavby si pečlivě prostudujte stavební návod. Při používání barev a lepidel pracujte v dobře větrané místnosti. Lepidla ani barvy nepoužívejte v blízkosti otevřeného ohně. Model není určen malým dětem, mohlo by dojít k požití drobných dílů.

## INSTRUCTION SIGNS \* INSTR. SYMBOL \* INSTRUKTION SINNBILDEN \* SYMBOLES \* 記号の説明



OPTIONAL  
VOLBA



BEND  
OHNOUT



SAND  
BROUSIT



OPEN HOLE  
VYVRTAT OTVOR



SYMMETRICAL ASSEMBLY  
SYMETRICKÁ MONTÁŽ



REMOVE  
ODRŽNOUT



REVERSE SIDE  
OTOCIT



APPLY EDUARD MASK  
AND PAINT  
POUŽIT EDUARD MASK  
NABARVIT

## PARTS

## \* DÍLY

## \* TEILE

## \* PIÈCES

## \* 部品

## PLASTIC PARTS

A&gt;

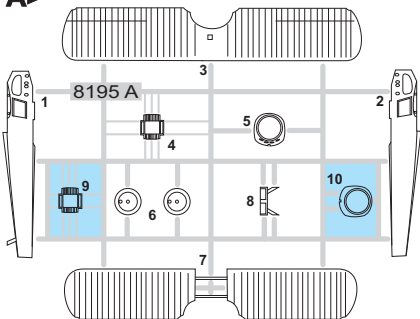

C&gt;

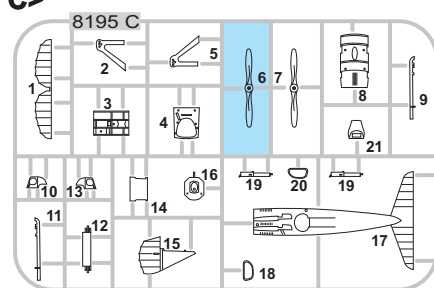

D&gt;

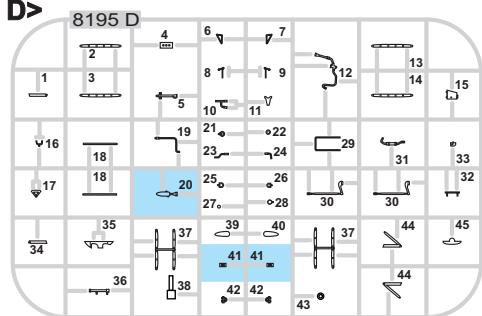

E&gt;

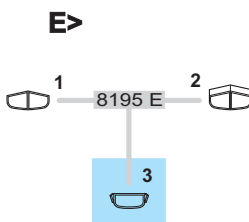
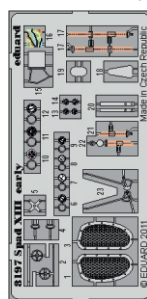
PE - PHOTO ETCHED  
DETAIL PARTS

-Parts not for use. -Teile werden nicht verwendet. -Pièces à ne pas utiliser. -Tyto díly nepoužívejte při stavbě. - 使用しない部品

## COLOURS

## \* BARVY

## \* FARBEN

## \* PEINTURE

## \* 色

GSI Creos (GUNZE)		MISSION MODELS	
AQUEOUS	Mr.COLOR	PAINTS	
[H10]	[C10]	[MMP-004]	COPPER
[H12]	[C33]	[MMP-047]	FLAT BLACK
[H37]	[C43]	[MMP-047]	WOOD BROWN
[H47]	[C41]	[MMP-012]	RED BROWN
[H51]	[C11]	[MMP-063]	LIGHT GULL GRAY
[H53]	[C13]	[MMP-063]	NEUTRAL GRAY
[H64]	[C17]	[MMP-087]	DARK GREEN
[H66]	[C119]	[MMP-119]	SAND YELLOW
[H85]	[C45]	[MMP-078]	SAIL COLOR
[H72]	[C22]	[MMP-078]	DARK EARTH

GSI Creos (GUNZE)		MISSION MODELS	
AQUEOUS	Mr.COLOR	PAINTS	
[H77]	[C137]	[MMP-040]	TIRE BLACK
[H303]	[C303]	[MMP-066]	GREEN
[H323]	[C323]	[MMP-066]	LIGHT BLUE
Mr.METAL COLOR		METALLICS	
[MC214]	[C214]	[MMM-001]	DARK IRON
[MC218]	[C218]	[MMM-003]	ALUMINIUM
[MC219]	[C219]	[MMM-009]	BRASS
Mr.COLOR SUPER METALLIC		METALLICS	
[SM01]	[C01]	[MMC-001]	SUPER CHROME

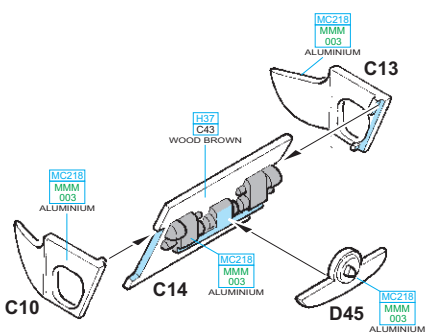
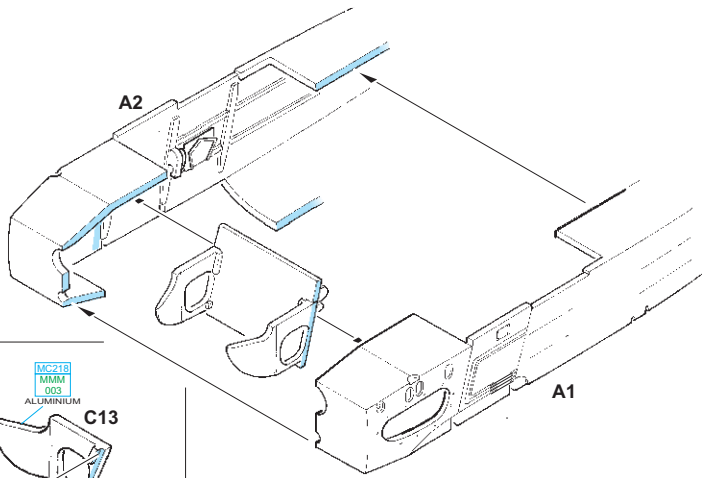
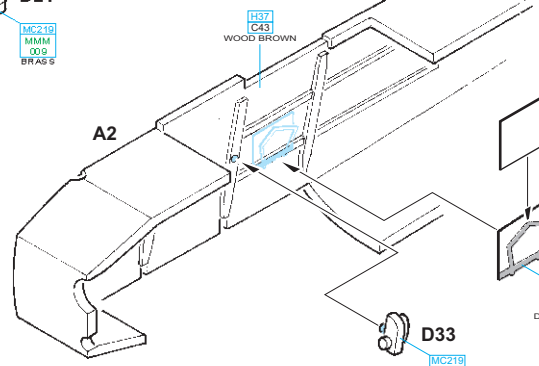
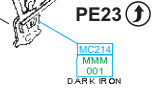
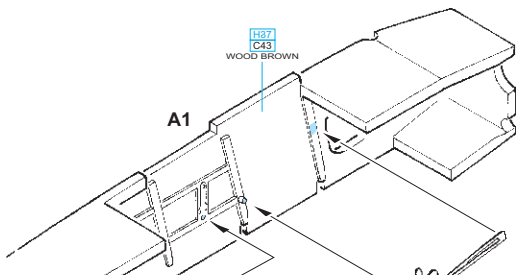

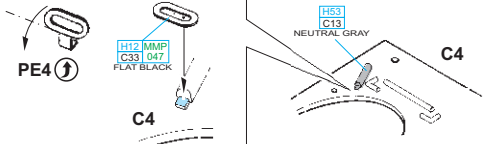
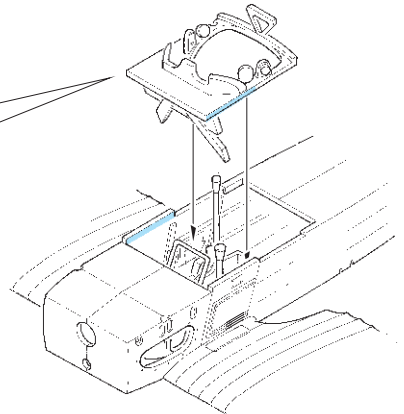
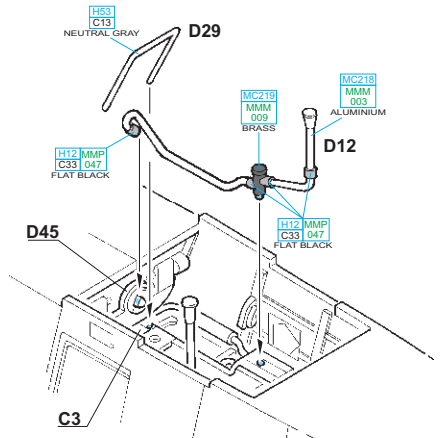
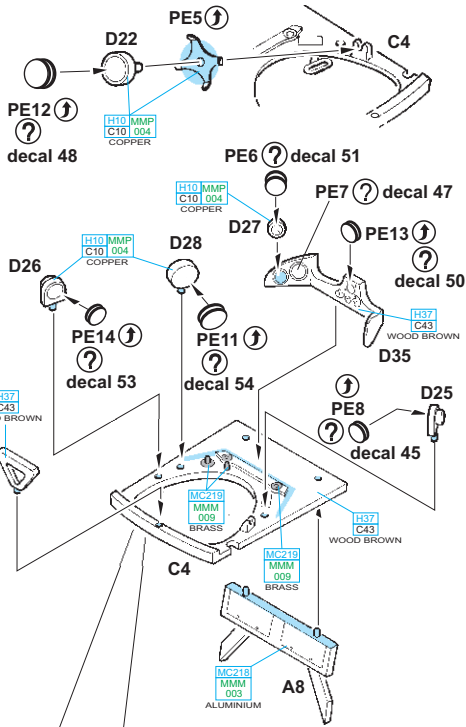
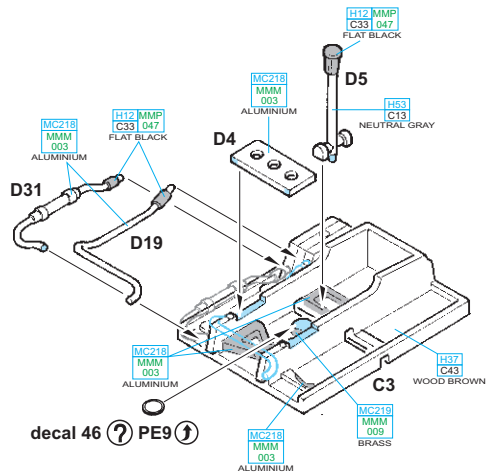
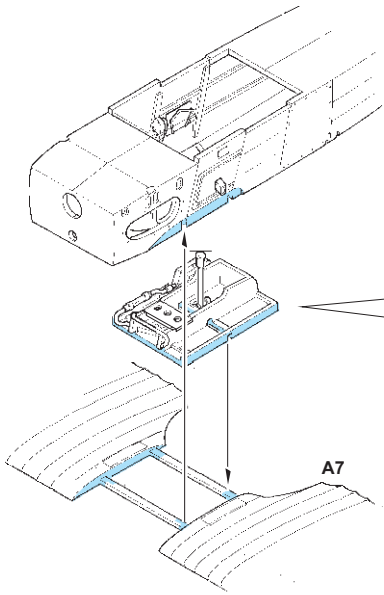

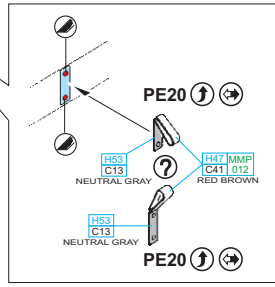
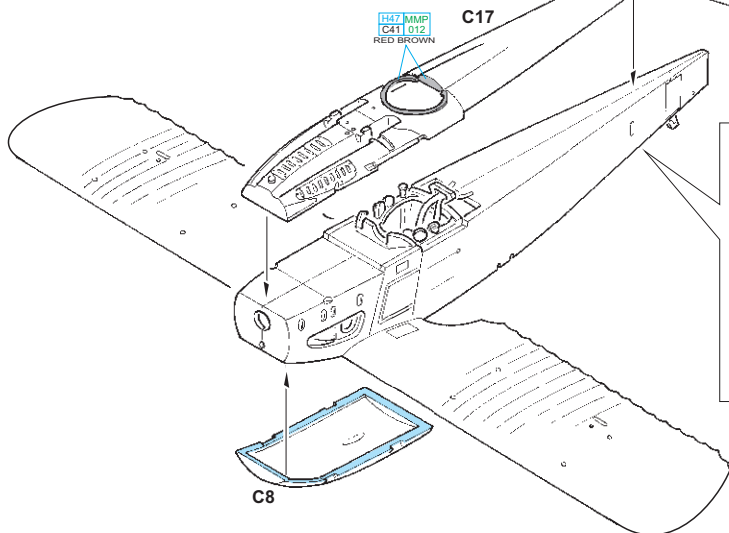
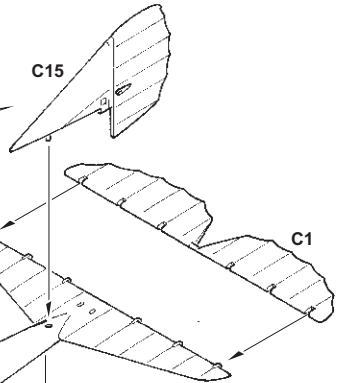
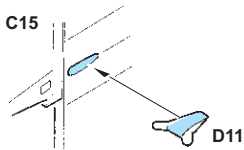
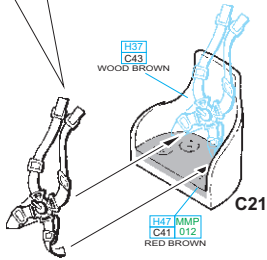
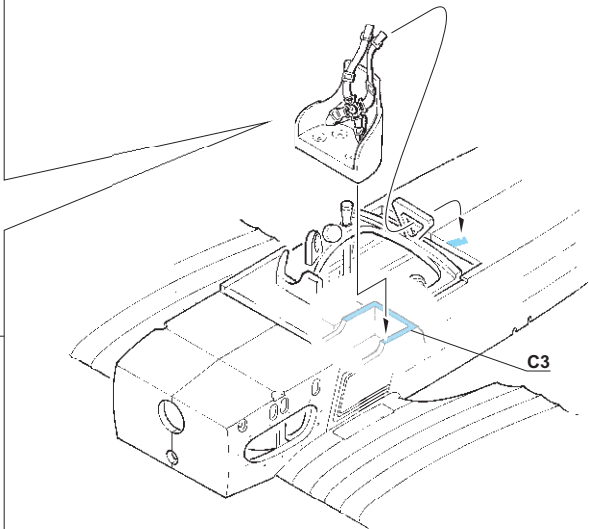
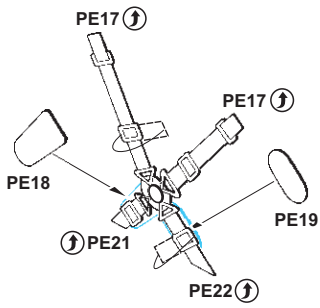

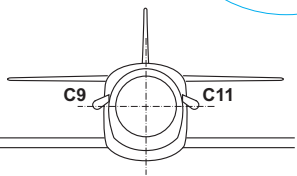
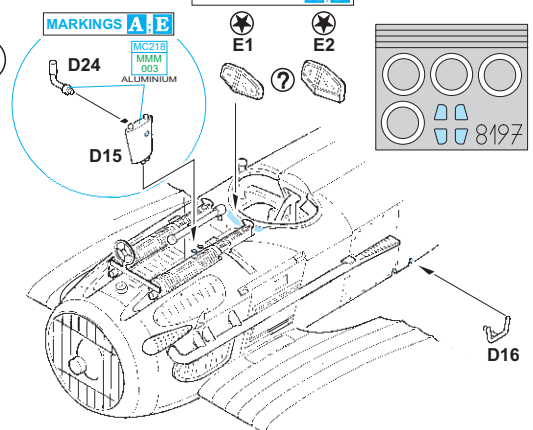
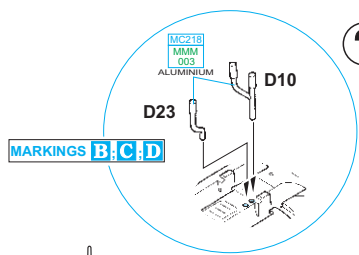
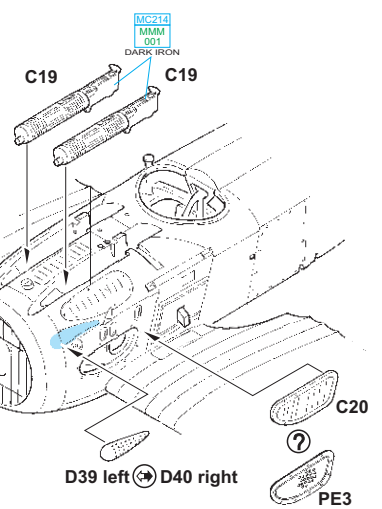
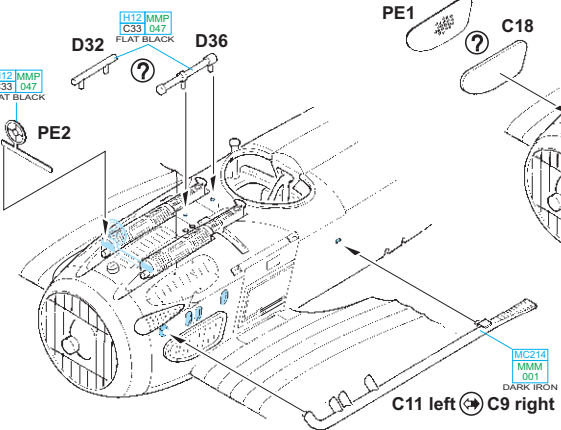
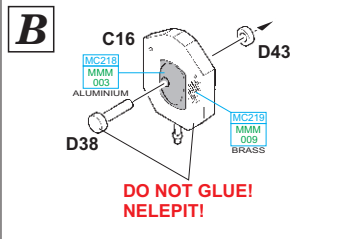
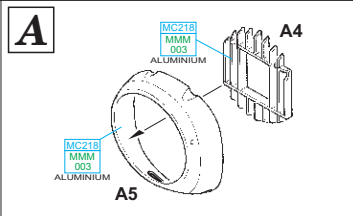
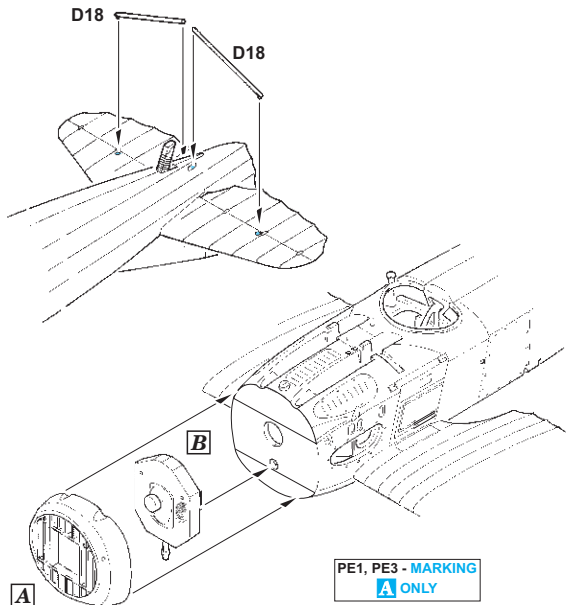

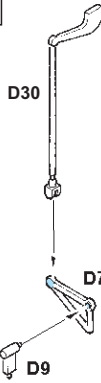
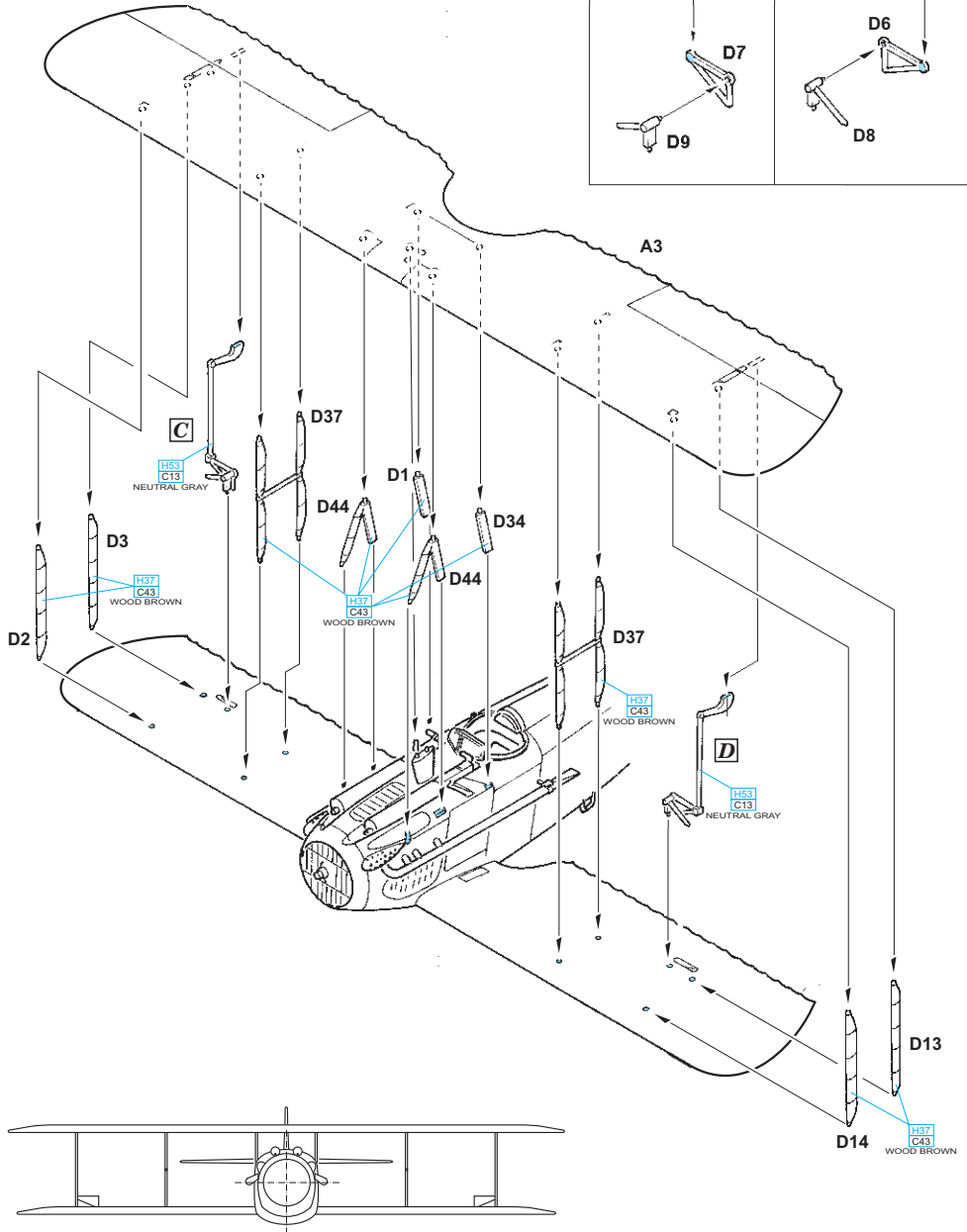
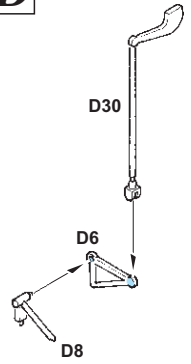
**C****D**

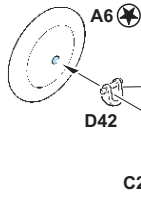
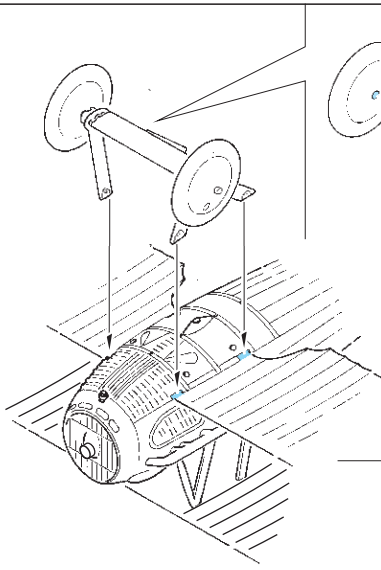

A6 2 pcs. A6 2 pcs.

**DO NOT GLUE!  
NELEPIT!**

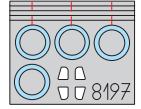

**DO NOT GLUE!  
NELEPIT!**

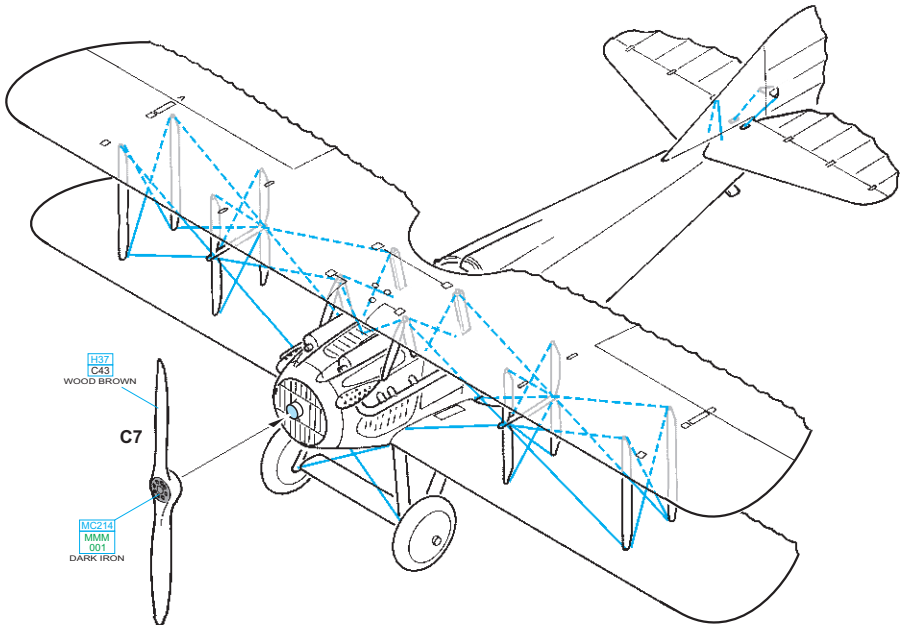
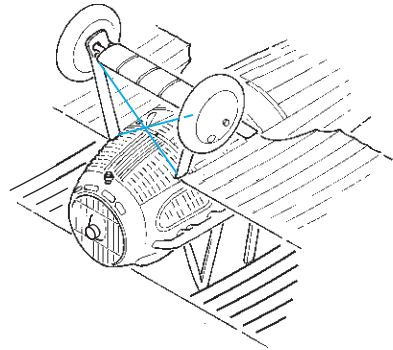
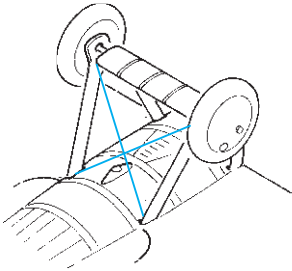
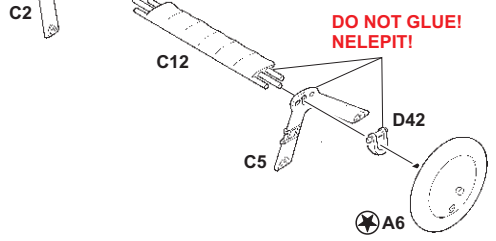

H37  
C43  
WOOD BROWN

C7

MC2-14  
MM8  
001  
DARK IRON

# A flown by Adj. Jacques Roques, Escadrille No. 48, France, Fall 1917

Combat operations were also participated in by citizens of countries outside of the warring nations. Among them was Paris-born, but Swiss by citizenship, Jacques Roques. He flew with Escadrille No.48, which had a rooster head as its emblem. Its motto was 'Chante et Combat' (Sing and Fight), which seemed rather appropriate at the time. Roques gained five confirmed kills with the French air force, and two more unconfirmed ones, all while serving with Escadrille No.48.

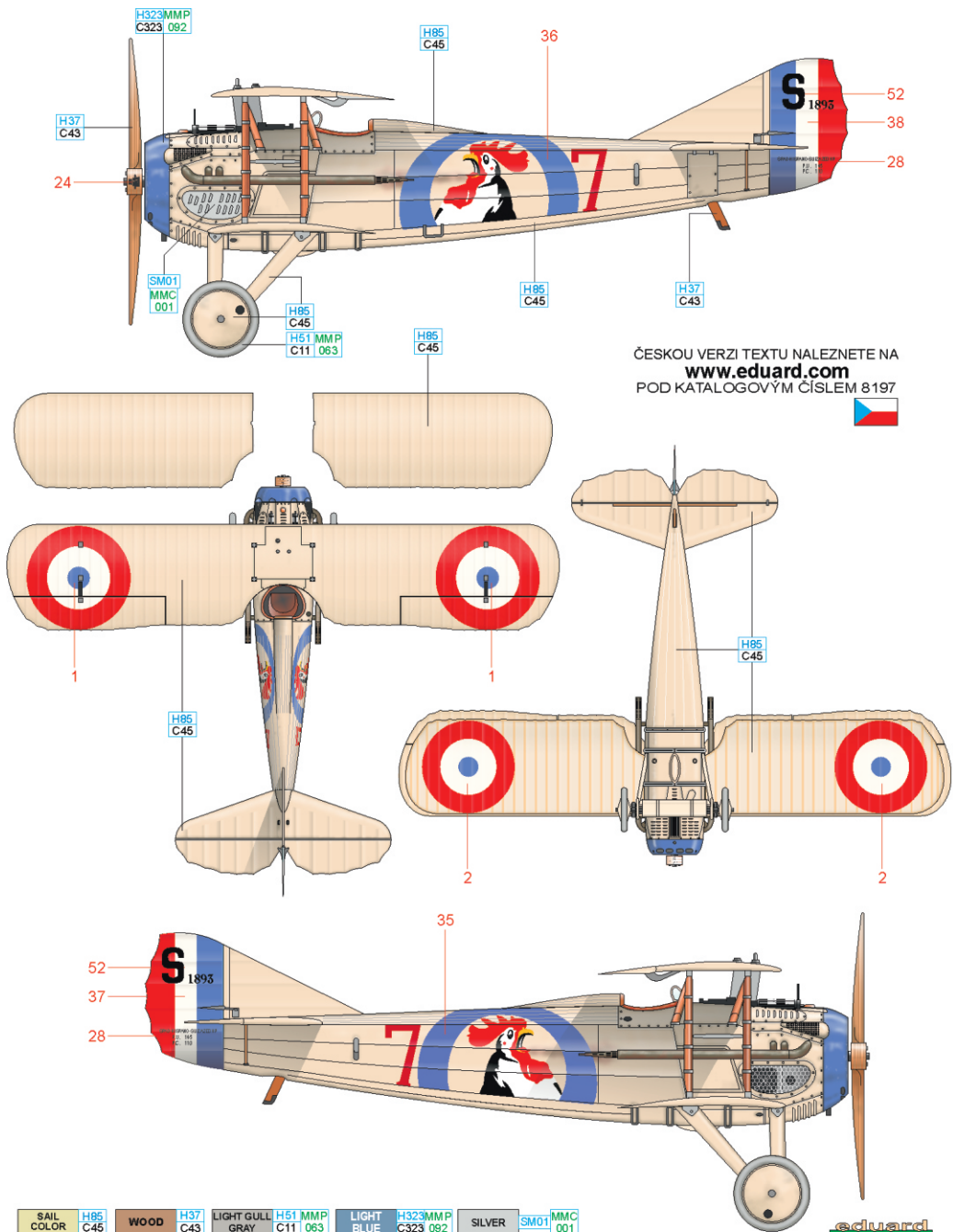

# B flown by Cne. Georges Guynemer, Escadrille No. 3, France, September 1917

Only a few fliers were able to achieve the honor of becoming certified celebrities in their lifetime. Into this category, we can certainly add without reservation the Frenchman Georges Guynemer. Georges Guynemer entered the armed forces as a volunteer in November 1914. He joined the air force in April 1915, where he would end up with Escadrille No.3, at the time equipped with the Morane-Saulnier monoplane. His first victory came by July 15th, 1915, and continually rose to eventually hit 53. He also had 35 unconfirmed kills. His most productive day came on May 25th, 1917, when he accounted for four confirmed victories. He became the first allied pilot to down a German Gotha G.III on February 8th, 1917. On the other hand, he managed to survive being shot down seven times, despite never having a parachute at his disposal. Guynemer's fate was sealed on September 11th, 1917, during combat. He fell victim to Lt. Kurt Wissemann, member of Jasta 3.

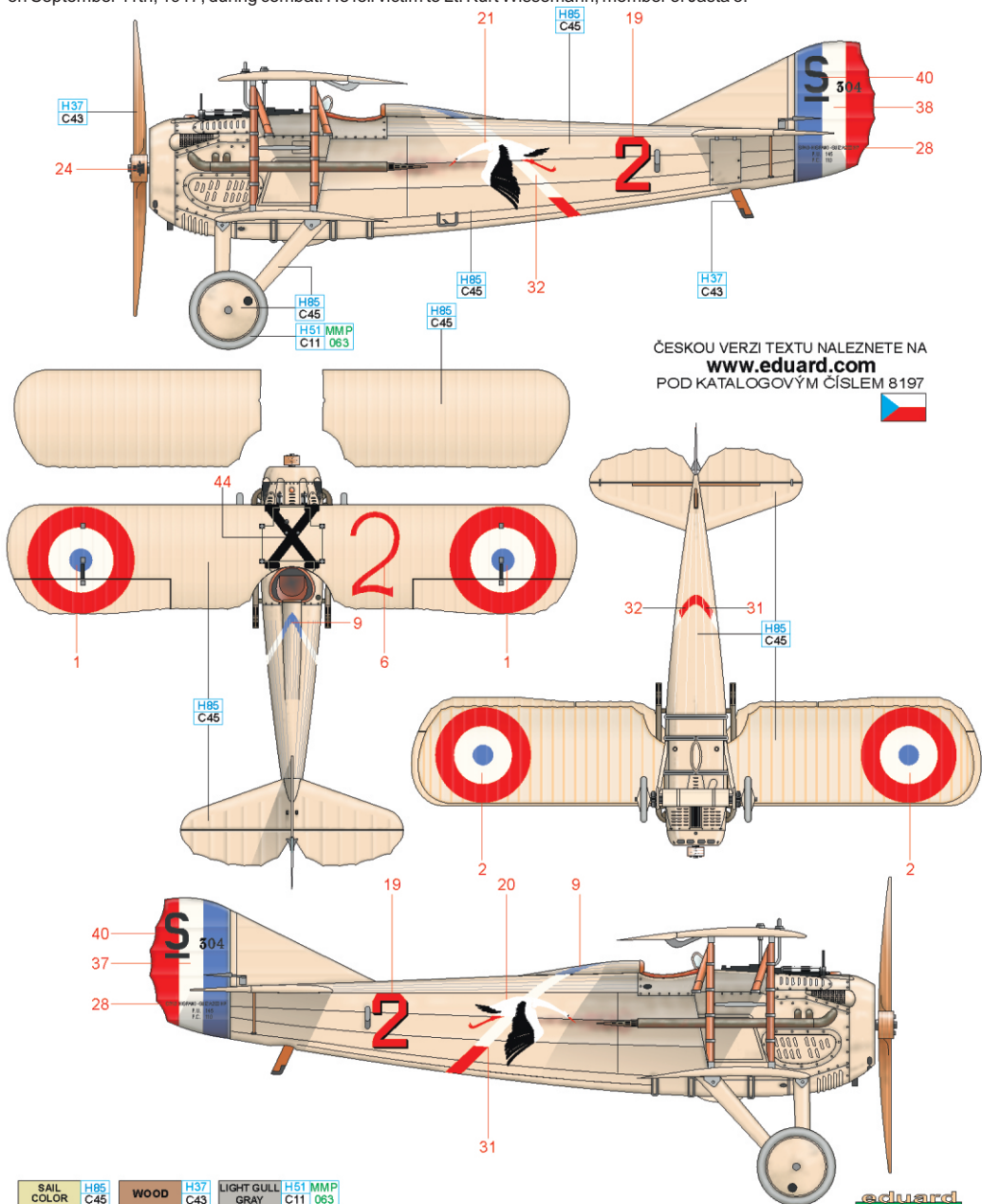

ČESKOU VERZI TEXTU NALEZNETE NA  
**www.eduard.com**  
 POD KATALOGOVÝM ČÍSLEM 8197



SAIL COLOR	H85 C45	WOOD	H37 C43	LIGHT GULL GRAY	H51 MMP C11 063
------------	---------	------	---------	-----------------	-----------------

eduard

# C flown by Lt. J.D. Hewett, No. 23 Squadron, Royal Flying Corps, France, February 1918

This aircraft was built under license by Kellner, one of nine manufacturers of the SPAD XIII. On February 19th, 1918, Lt. Hewett shot down a German two-seat aircraft flying this SPAD. A week later, on February 26th, 1918, this aircraft fell into the hands of Germany virtually undamaged, when it was forced to land by Adolf Ritter von Tutschek (total 27 victories) of Jasta 12 flying the Fokker Dr.I. The British pilot survived the war in a POW camp.

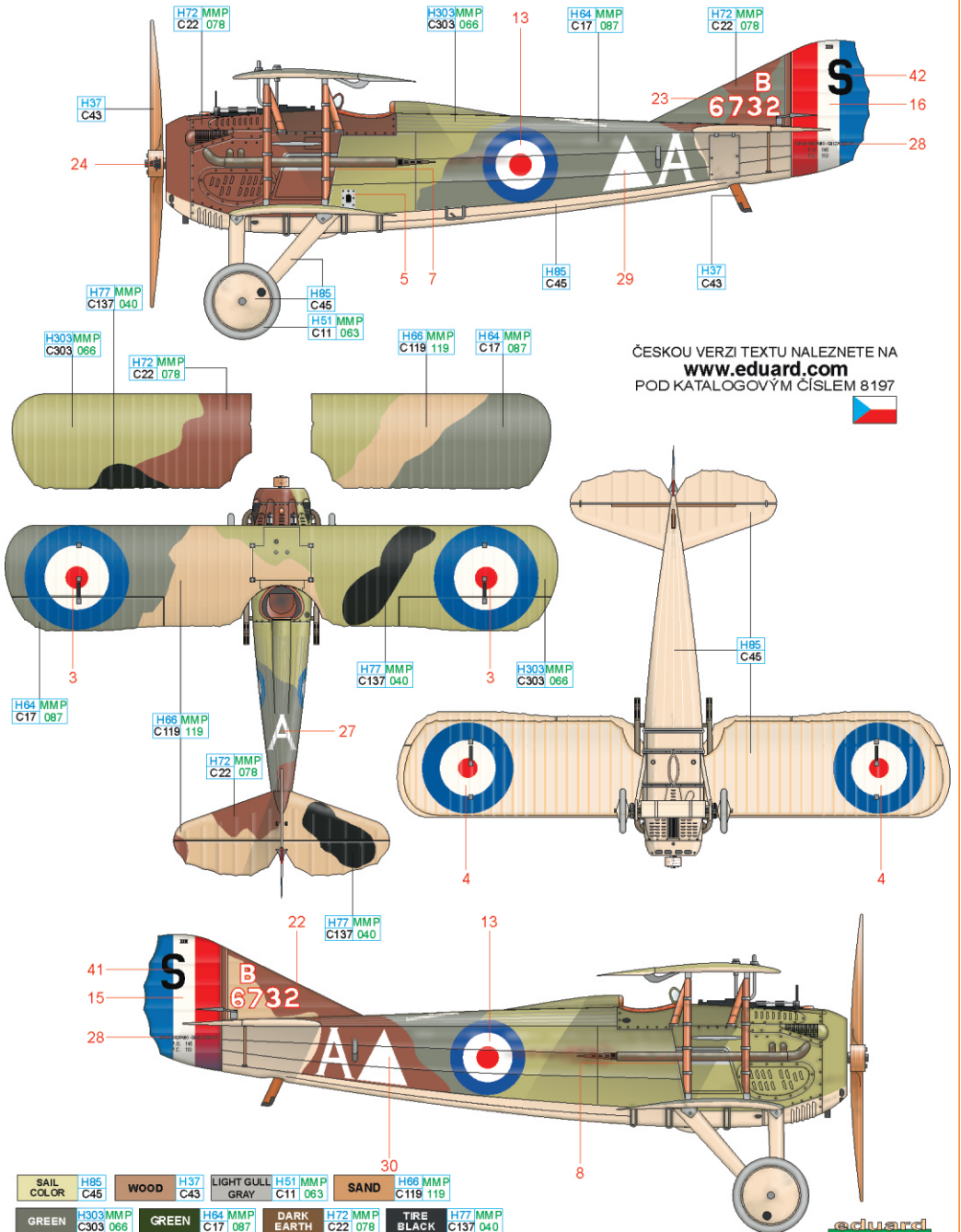

# D Flown by Maj. Francesco Baracca, 91a Squadriglia, Italy, May 1918

Francesco Baracca figures very prominently on the ladder of Italian aces of the First World War. He began the road to being a pilot as early as 1912, and by May 1915, when Italy entered the war, he was able to offer a good amount of experience. Much of this experience was expressed while flying the Nieuport and the SPAD. In all, he reached 34 victories. He fell during the last year of the war, on June 19th, 1918. He likely fell victim to the Austro-Hungarian pilot Oblt. Arnold Berwing, member of Flik 28D, where he also flew as an observer on the Phonix C.I. Baracca left his mark not only in aviation, but also in the auto industry. After his death, his mother granted his personal emblem to Enzo Ferrari, and so, in a way, accompanied the likes of Jacky Ickx, Niki Lauda, Gilles Villeneuve, Alain Prost and Michael Schumacher during great automotive accomplishments.

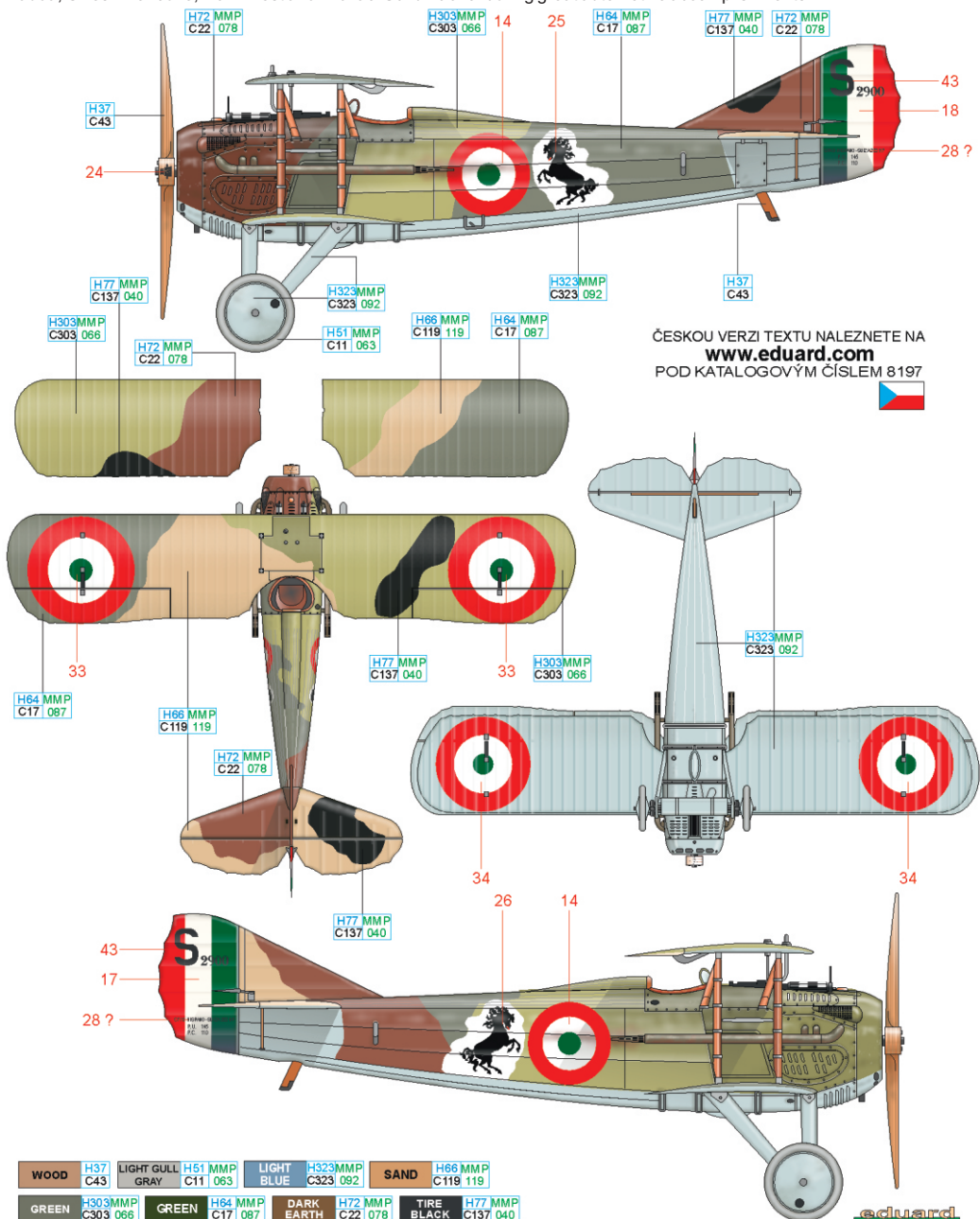

ČESKOU VERZI TEXTU NALEZNETE NA  
**www.eduard.com**  
 POD KATALOGOVÝM ČÍSLEM 8197



WOOD	H37 C43	LIGHT GULL GRAY	H51 MMP C11 063	LIGHT BLUE	H323MMP C323 092	SAND	H66 MMP C119 119
GREEN	H303MMP C303 066	GREEN	H64 MMP C17 087	DARK EARTH	H72 MMP C22 078	TIRE BLACK	H77 MMP C137 040

eduard

