

## 1/48 SCALE PLASTIC KIT



Produced under license.  
Boeing, P-51 Mustang  
their distinctive logos,  
product markings and  
trade dress are trademarks  
of The Boeing Company.



# ProfiPACK #82103

edition

### INTRO

The P-51 Mustang is regarded as one of the best pursuit aircraft of all the time and although American airplane, it owes a lot to the Great Britain for its genesis. It was in 1940, when British Buying Committee asked North American Aviation (NAA) to build the Curtiss P-40s for the RAF. NAA president James Kindelberger offered British development of much better plane instead. British agreed and the design team led by chief designer Edward Schmued, who was, by the way, German immigrant with Austrian roots, started to work. The preliminary design was approved on May 4th, 1940, final assembly, and engine installation began on September 9th (just 127 days after approval) and the first flight of the NA-73X prototype followed on October 26th.

#### Innovative fighter

The Allison V-1710-39 liquid cooled in-line engine rated at 1,100hp was chosen for the new fighter and the designers did their best to create as narrow and sleek fuselage as possible around it to lower the drag. For the same reason, the laminar flow airfoil was used for very first time on production aircraft. On the other hand, such a profile requires clean wing surface, so it was puttied and smoothed by sanding. Another design novelty was the radiator belly under the fuselage, providing some additional thrust thanks to the Meredith effect. The armament consisted of two guns in the nose and four in the wings, all of them .50 caliber Brownings (while the Mk. Ia variant had four 20mm cannons). British chose the name Mustang for the new aircraft, later adopted by USAAF as well. The RAF received their first Mustangs Mk.I in October 1941. The performance was found satisfactory, as it was faster than the Spitfire Mk.V and provided more than double the range. On the other side, the Allison engine reached its maximum power at only 11,800ft (3597m) as it was fitted with single stage supercharger only. Above this level the engine performance decreased rapidly. As the aerial combats occurred much higher, the RAF decided to use their Mustangs in the reconnaissance role and US Army Air Corps, interested in the new type as well (but bound to the contracts to build P-40, P-39 and P-38 pursuits), asked the NAA to convert the Mustang as a dive bomber with wing dive brakes (the A-36 variant) and also started to use the new type for reconnaissance and photo-reconnaissance purposes.

#### Merlin magic

To solve the high-altitude weakness, the work had begun in Britain to fit the Mustang with the two-stage supercharged Merlin engine. The trials of the Mustang X prototype revealed maximum speed of 433mph (697km/h) at 22,000ft (6700m), 100mph (161km/h) faster than Mustang Mk.I. Thanks to that, NAA started the design work, using Packard V-1650-1 (license built Merlin 61). As the Packard unit sported some design changes, it was not possible to fit the resulting Mustangs with original Merlins. The need of intercooler for two-stage supercharger necessitated bigger radiator duct, the carburetor intake moved from upper to the lower side of the nose. Another main change was removal of the fuselage guns. The production started at the Inglewood plant as P-51B on May 1943 and at the new production line at NAA Dallas plant as P-51C in August 1943. Also, the supplies to RAF continued as Mustang Mk.III. After just handful of the new Mustangs were produced, then commander of US Air Forces in Europe General Henry Arnold asked for even greater range. NAA responded with additional 85-gallon tank installed behind the pilot's seat.

The P-51B/C were great fighters but lacked backward visibility and suffered with gun jamming. The RAF found particle solution of the visibility issue with a "Malcolm Hood" semi-bubble canopy, but the design team of NAA decided to rework the Mustang again. The main change was the bubble canopy with lowered rear fuselage. The wing was reworked to accommodate six .50 cal guns and the new arrangement of ammo chutes eliminated the jam problem. Together with some other changes, the new P-51D Mustang, was born at the end of 1943 and the production started at both Inglewood (serials with -NA suffix) and Dallas (-NT) plants. Due to the short supply of the Hamilton Standard alloy propellers used on Merlin powered P-51s, the Dallas Factory was fitting their Mustangs with steel Aeroquip ones with hollow blades as the P-51K.

#### Photo reconnaissance Mustangs

During WWII, the USAAF used fifteen different aircraft specifically created for photo reconnaissance or mapping duties. These aircraft were designated with the F prefix (phonetically for Photo, as the P was already used for pursuit planes). The Mustang obtained the F-6 designation and 481 of these were manufactured. The production started in July 1941 with F-6A variant based on the initial Allison powered P-51 and culminated with F-6D and F-6K based on their appropriate pursuit variants. For the installation of the cameras, there were special fuselage openings and housings created at the Inglewood or Dallas factory and the aircraft were then sent to the modification centres for their camera and other special equipment installation process. For photo reconnaissance purposes, two K-24 cameras were fitted, first one being oblique, placed behind the pilot's seat and pointing to the left rear of the airplane, the other one was mounted in the tail section and was vertical (to be pointed by the pilot straight down). There were also changes in radio or oxygen system installations (the long-range oxygen system was fitted). Altogether 136 of F-6D and 163 of F-6K were built. Later, a few P-51Ds were converted to the recce standard becoming FP-51Ds and RF-51Ds. The reconnaissance Mustangs were used in all regions, where USAAF was operating and, as it kept its guns and flight performance, it did not need fighter escort. Thanks to that, several of the recce Mustangs pilots become aces with more than five aerial victories.

ATTENTION



UPOZORNĚNÍ



ACHTUNG



ATTENTION



注意



Carefully read instruction sheet before assembling. When you use glue or paint, do not use near open flame and use in well ventilated room. Keep out of reach of small children. Children must not be allowed to suck any part, or pull vinyl bag over the head.



Před započatím stavby si pečlivě prostudujte stavební návod. Při používání barev a lepidel pracujte v dobře větrané místnosti. Lepidla ani barvy nepoužívejte v blízkosti otevřeného ohně. Model není určen malým dětem, mohlo by dojít k požití drobných dílů.

INSTRUCTION SIGNS \* INSTR. SYMBOLS \* INSTRUKTION SINNBILDEN \* SYMBOLES \* 記号の説明

OPTIONAL  
VOLBABEND  
OHNOUTSAND  
BROUSITOPEN HOLE  
VYVRTAT OTVORSYMETRICAL ASSEMBLY  
SYMETRICKÁ MONTÁŽREMOVE  
ODŘÍZNOUTREVERSE SIDE  
OTOČITAPPLY EDUARD MASK  
AND PAINT  
POUŽIT EDUARD MASK  
NABARVIT

PARTS



DÍLY



TEILE



PIÈCES



部品

## PLASTIC PARTS

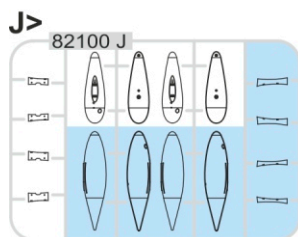
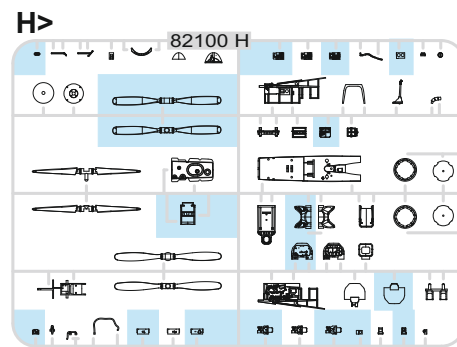
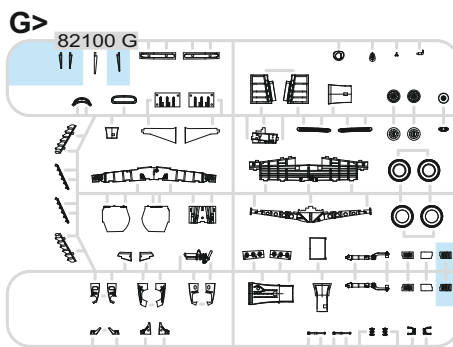
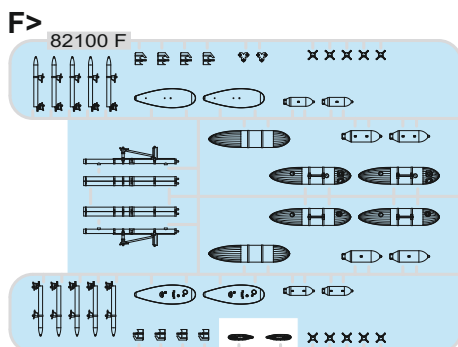
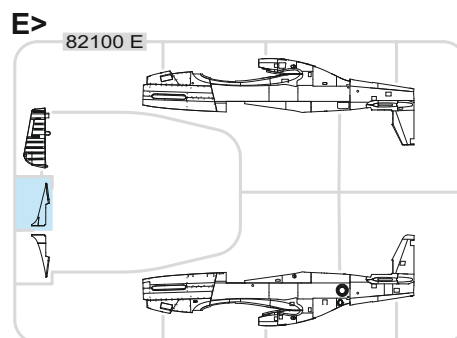
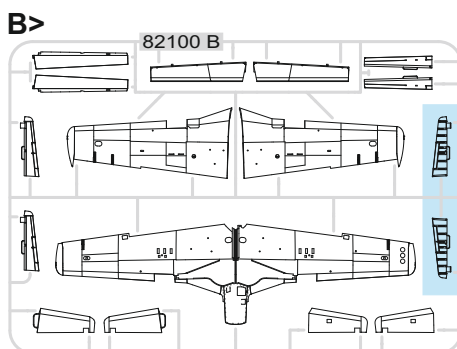
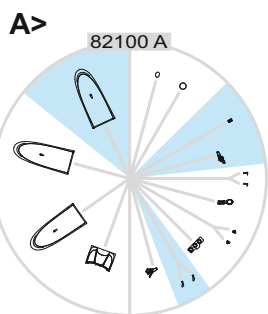

## PE - PHOTO ETCHED DETAIL PARTS

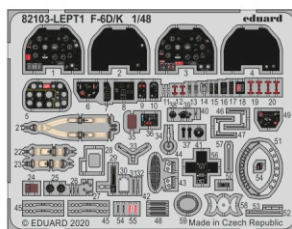
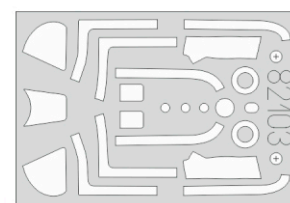
eduard  
MASK

-Parts not for use. -Teile werden nicht verwendet. -Pièces à ne pas utiliser. -Tyto díly nepoužívejte při stavbě. - 使用しない部品

COLOURS



BARVY



FARBEN



PEINTURE



色

GSI Creos (GUNZE)		MISSION MODELS	
AQUEOUS	Mr.COLOR	PAINTS	
H1	C1	MMP-001	WHITE
H8	C8		SILVER
H12	C33	MMP-047	FLAT BLACK
H27	C44		TAN
H37	C43		WOOD BROWN
H47	C41	MMP-012	RED BROWN
H52	C12	MMP-091	OLIVE DRAB
H58	C351	MMP-059	INTERIOR GREEN
H77	C137	MMP-040	TIRE BLACK
H90	C47		CLEAR RED

GSI Creos (GUNZE)		MISSION MODELS	
AQUEOUS	Mr.COLOR	PAINTS	
H91	C48		CLEAR YELLOW
H94	C138		CLEAR GREEN
H327	C327	MMP-101	RED
H329	C329		YELLOW
	C352		YELLOW CHROMATE
Mr.METAL COLOR		METALLICS	
	MC214	MMM-001	DARK IRON
Mr.COLOR SUPER METALLIC		METALLICS	
	SM201	MMC-001	SUPER FINE SILVER
	SM203		SUPER IRON

**A** 1 = 90% + 10%

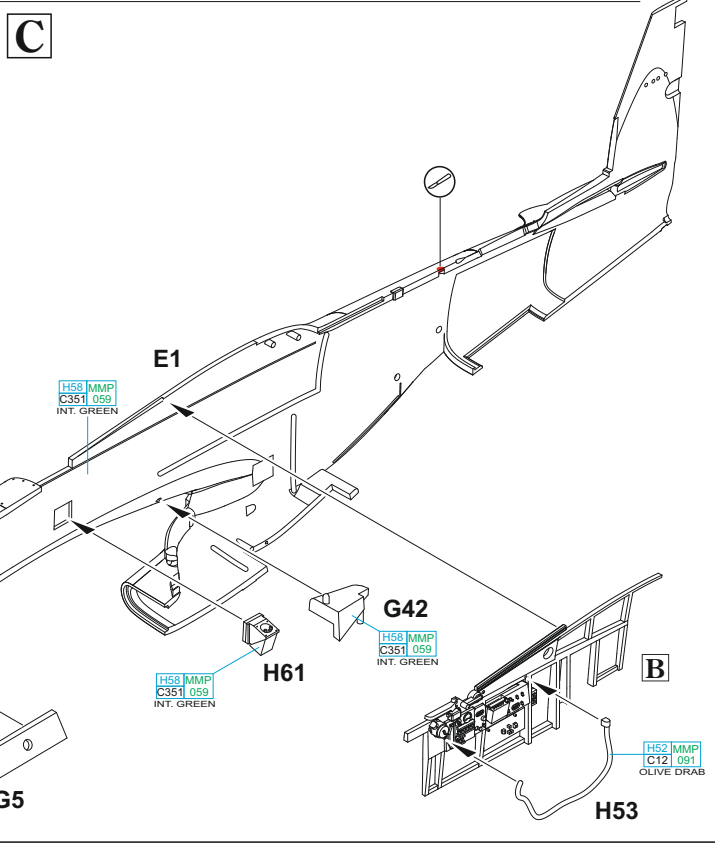
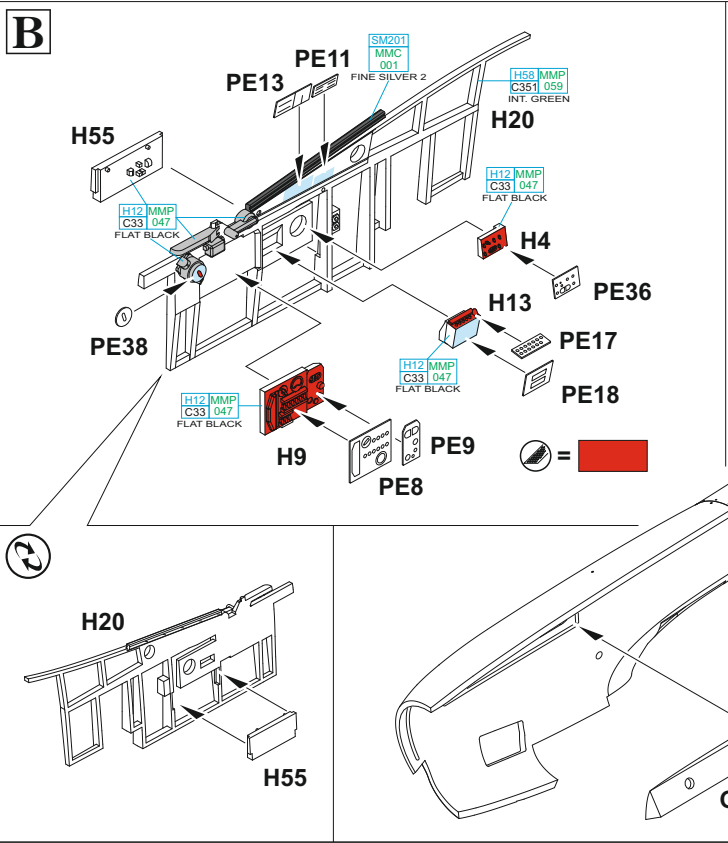
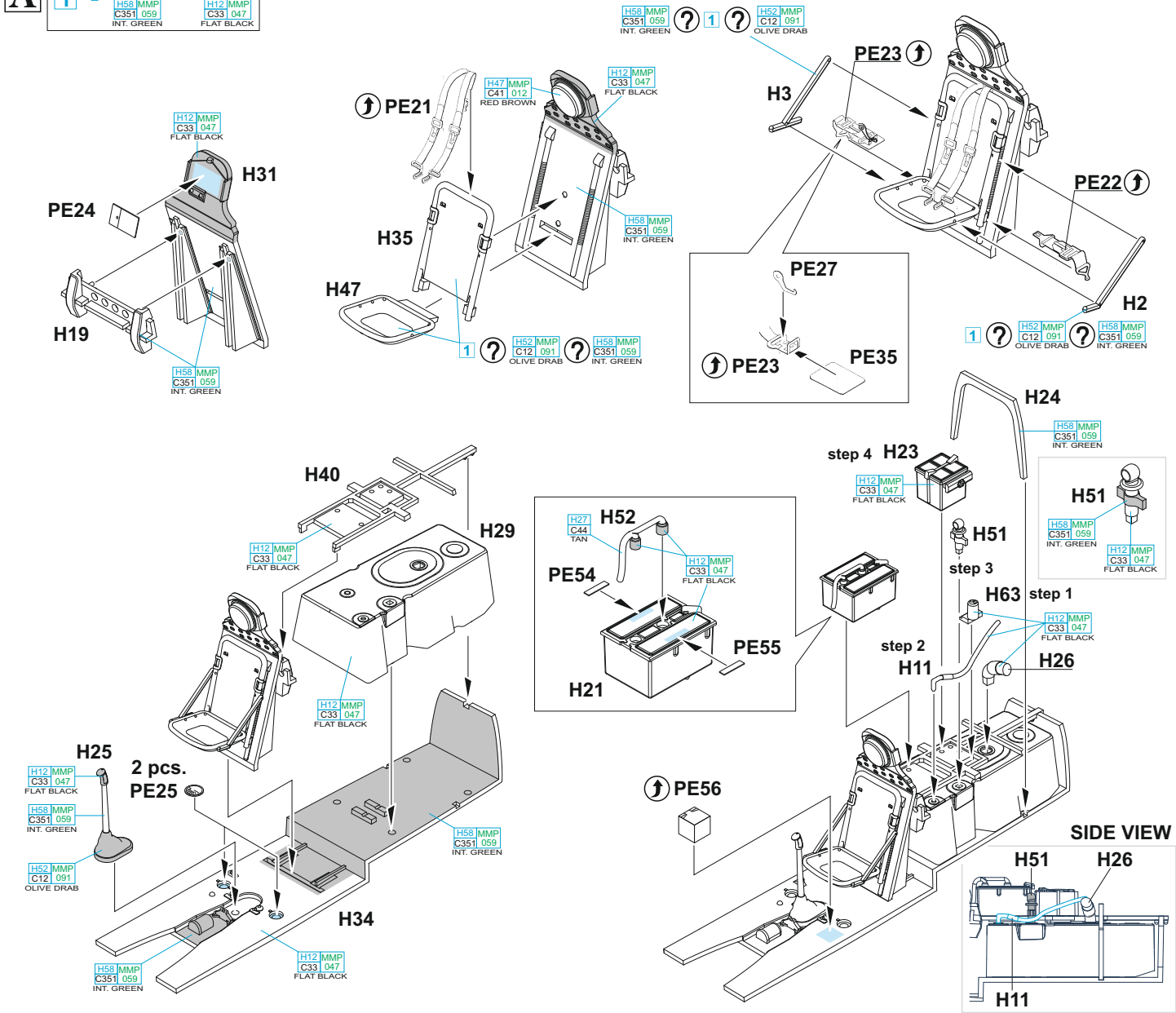

D

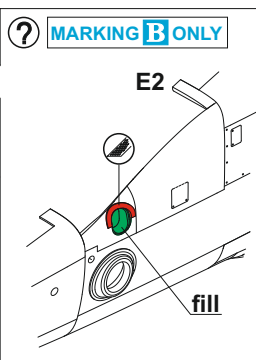
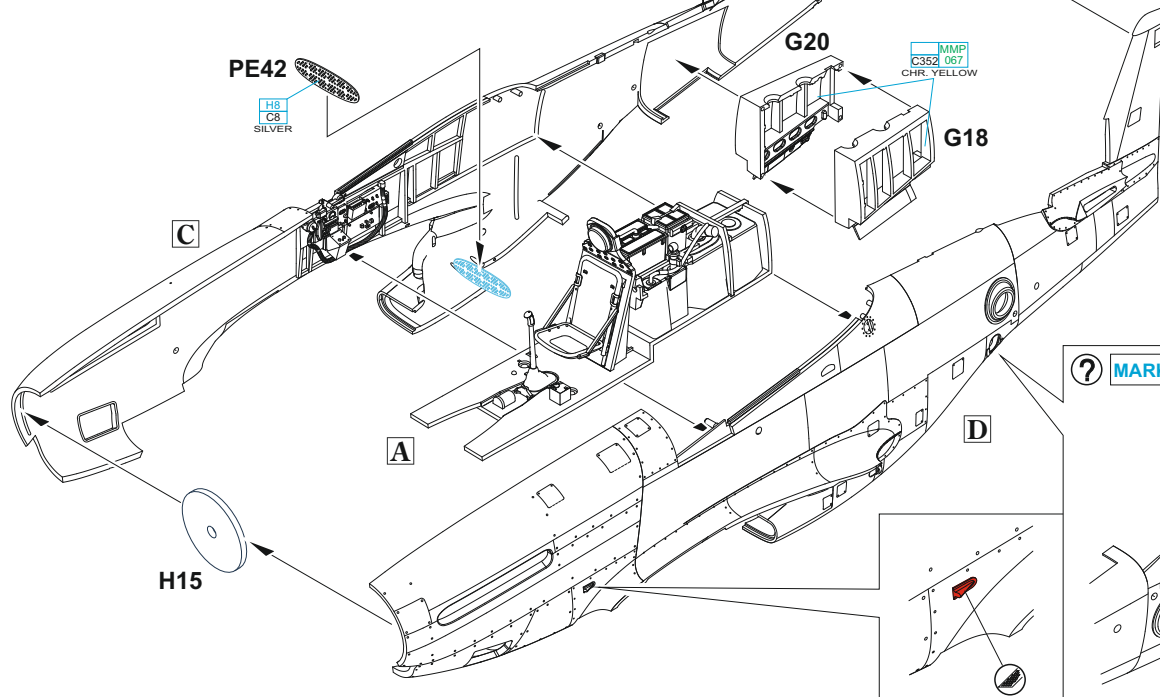
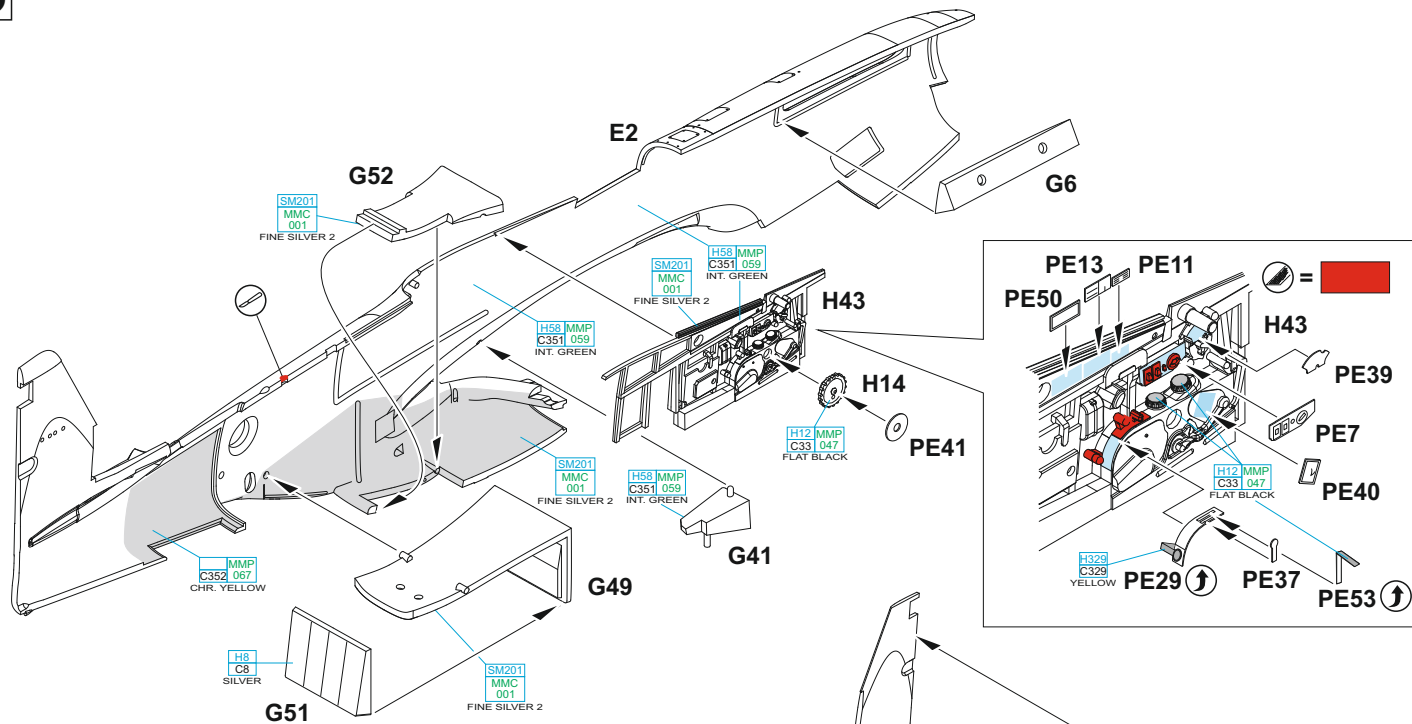

2 =   
 SM201 MMC 001 FINE SILVER 2 - MARKINGS B, C, F   
 MMP C352 067 CHR. YELLOW - MARKINGS A, D, E

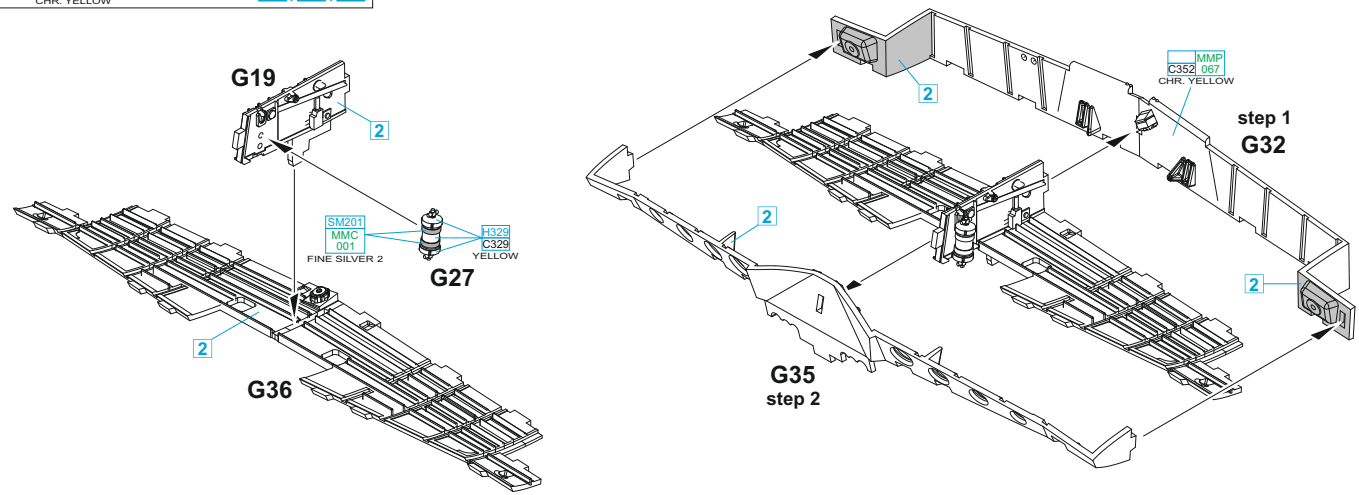

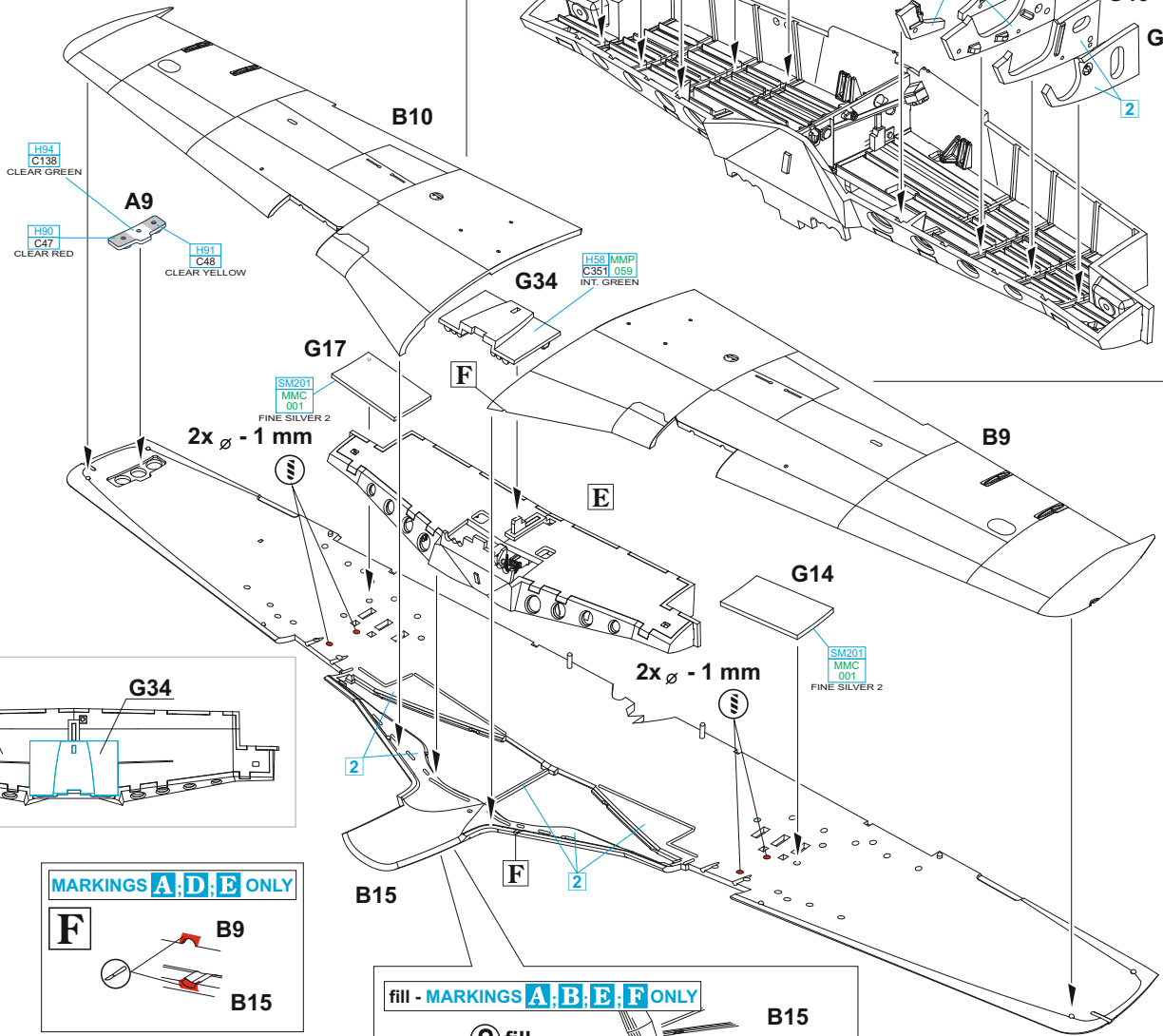
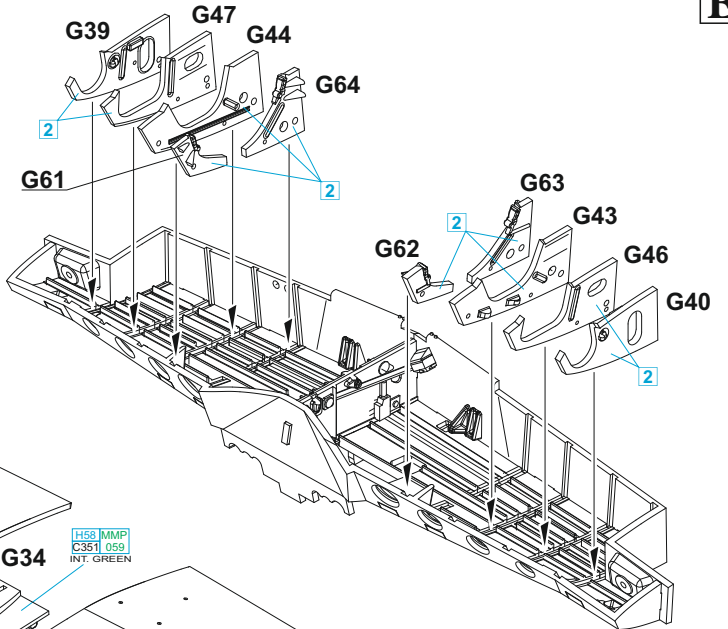
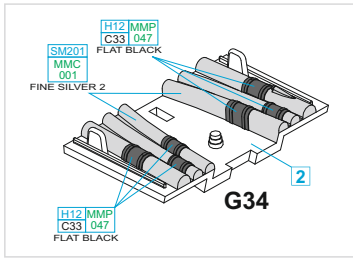

UPPER VIEW

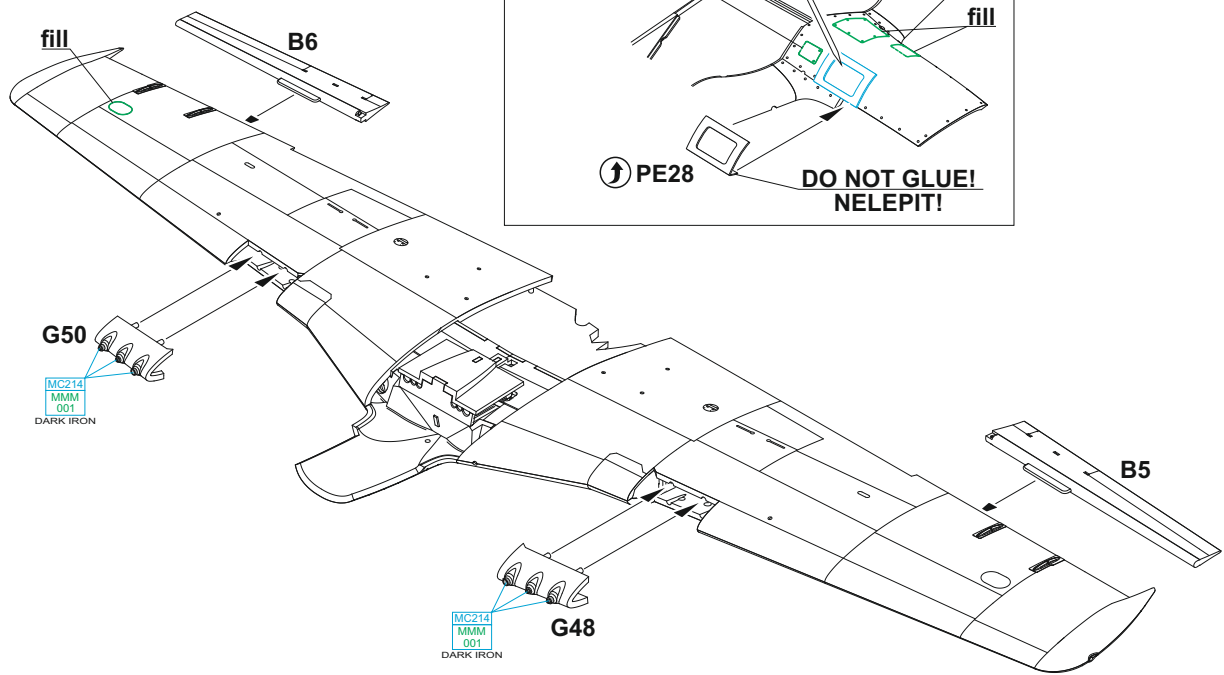
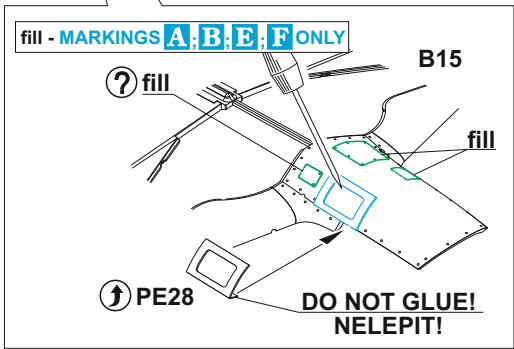
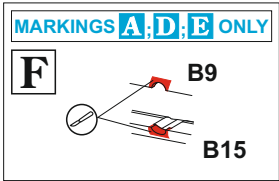
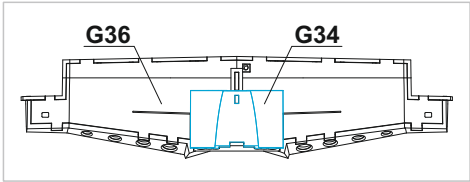

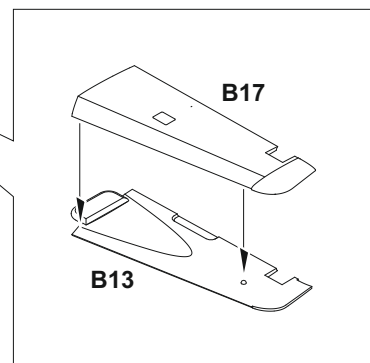
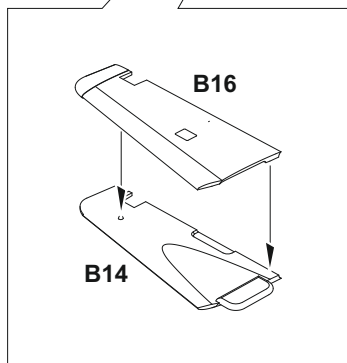
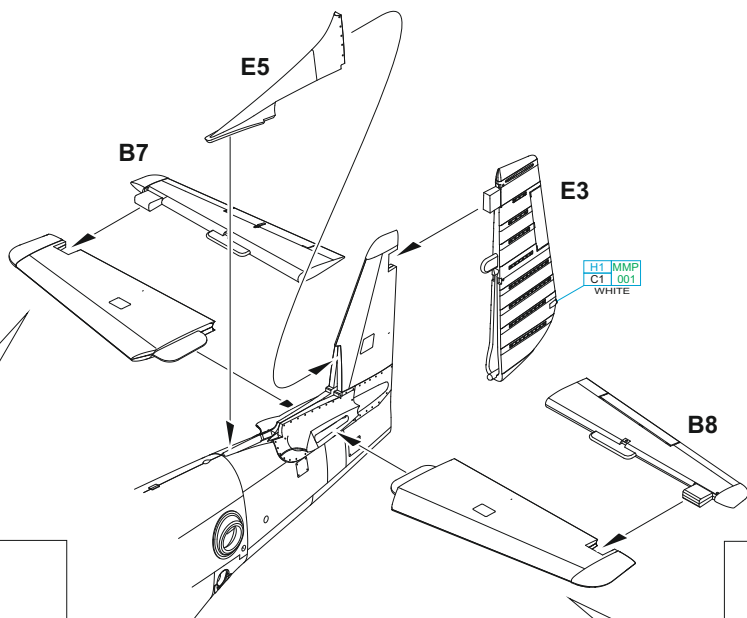
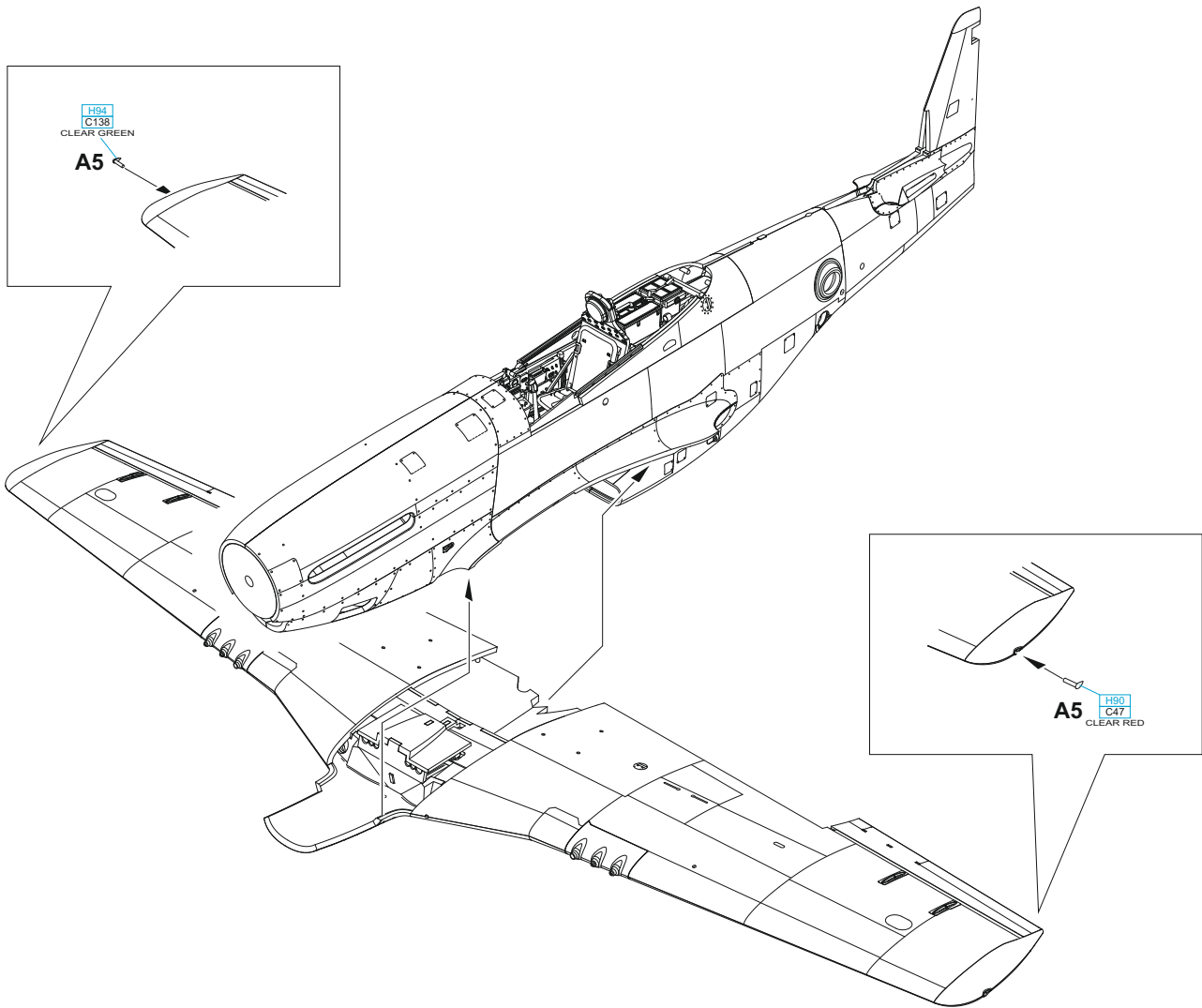

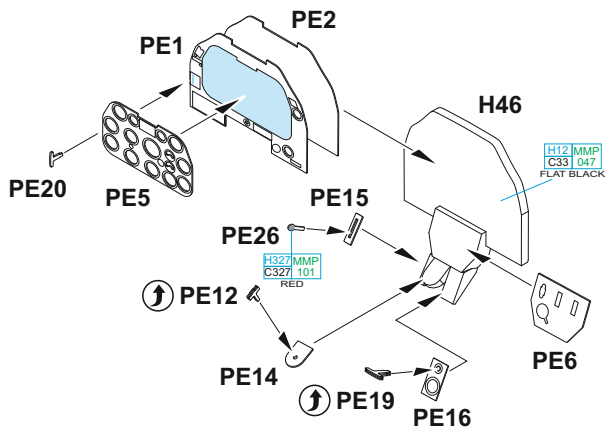

?

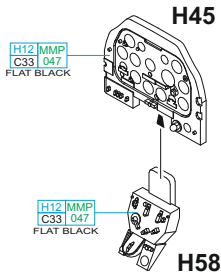

OPTIONAL: decals 58, 60, 62, 63, 64

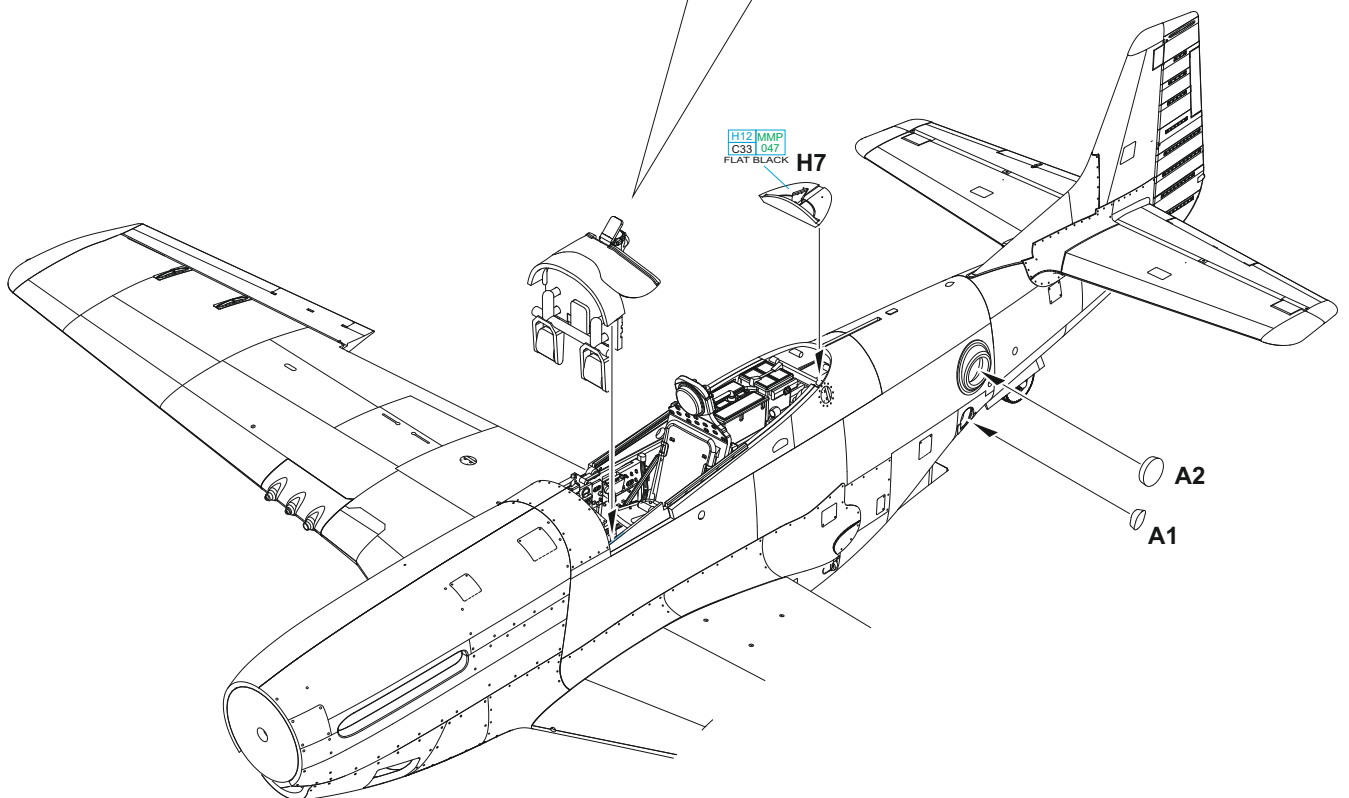
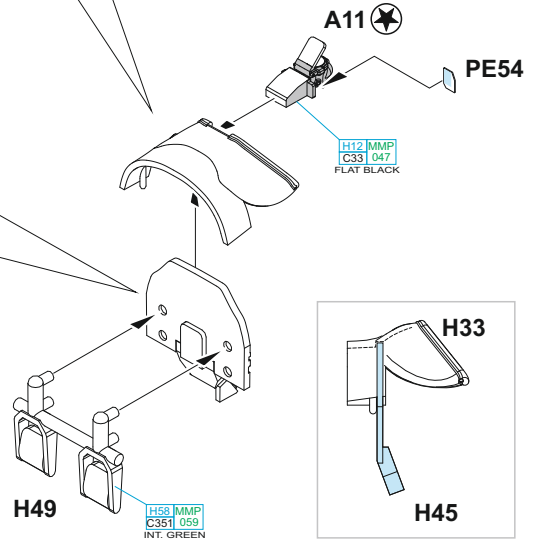
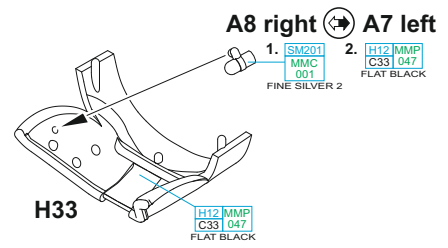
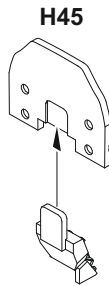

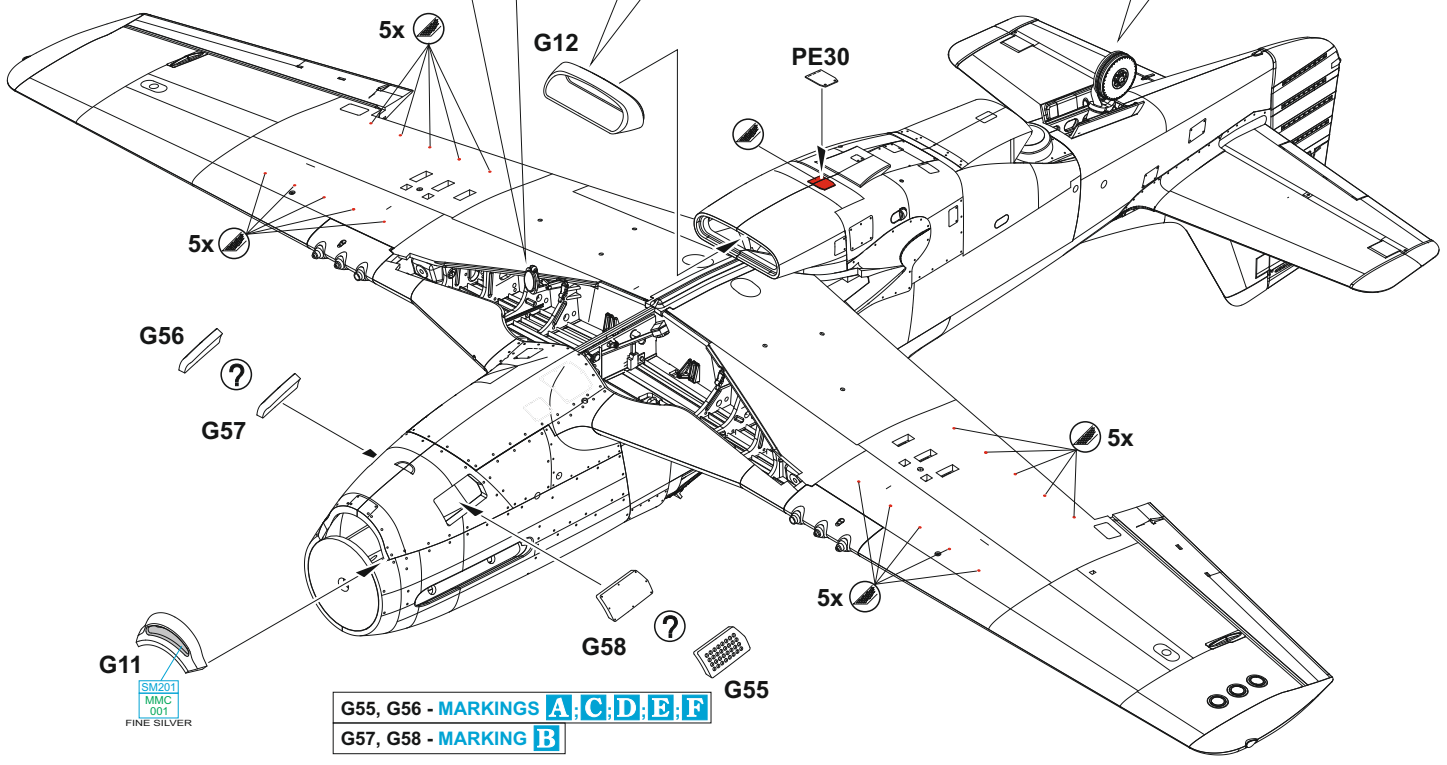
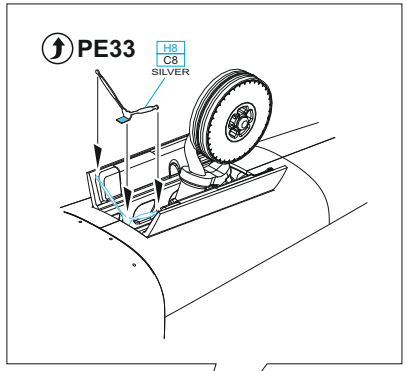
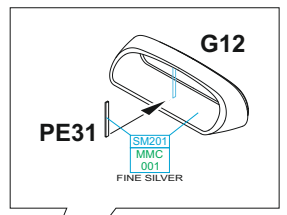
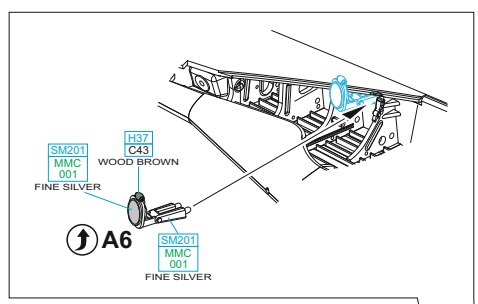
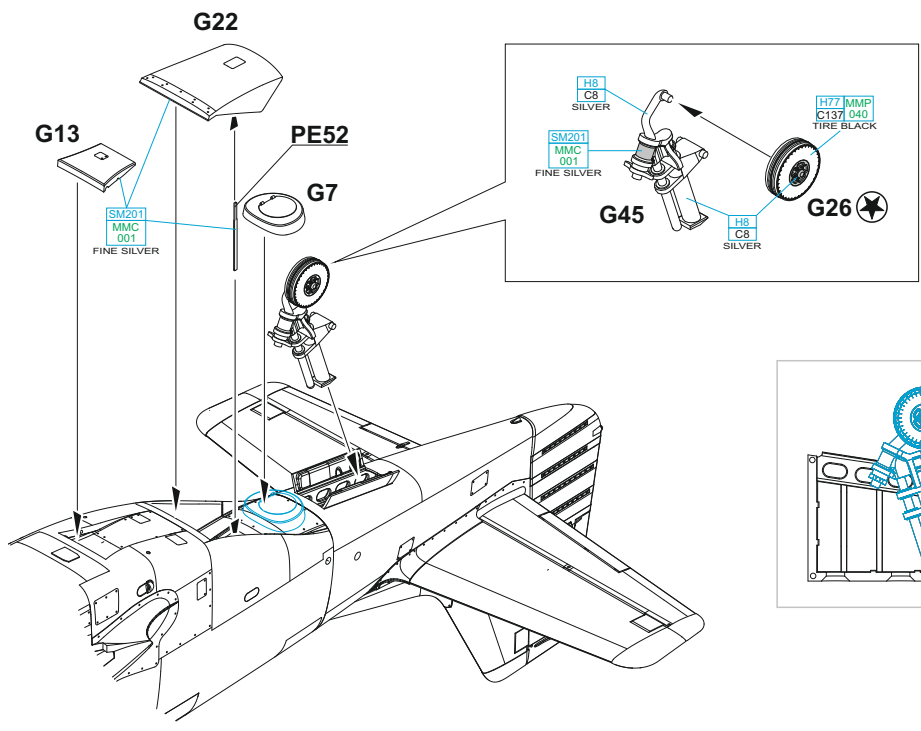

G55, G56 - MARKINGS **A C D E F**  
 G57, G58 - MARKING **B**

step 1 - G37, G38  
step 2 - G24, G25

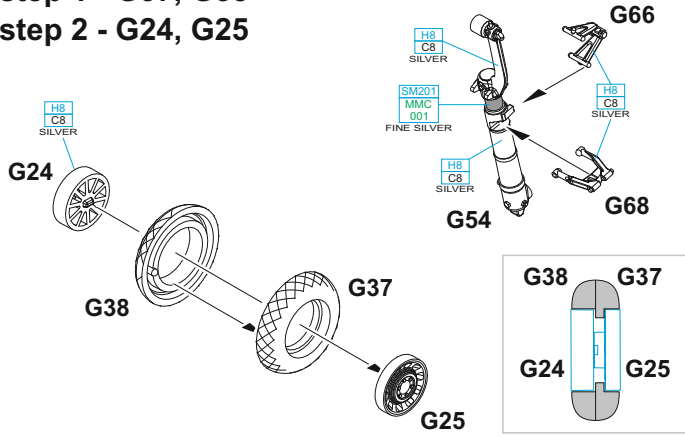

step 1 - G37, G38  
step 2 - G24, G25

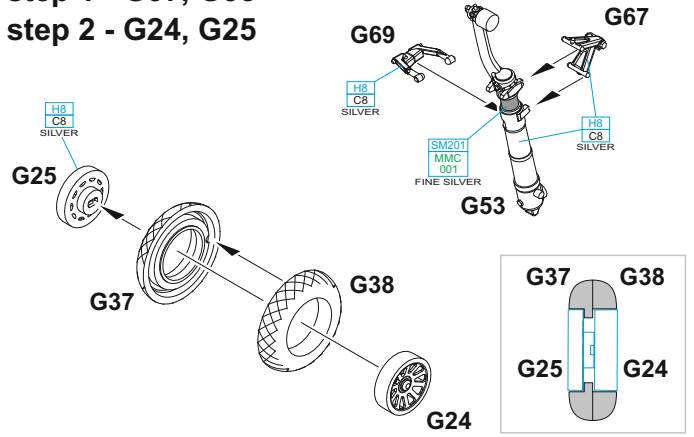

F

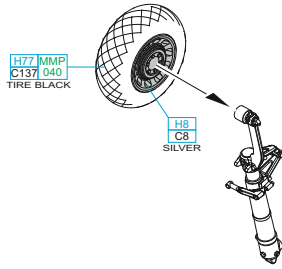

G

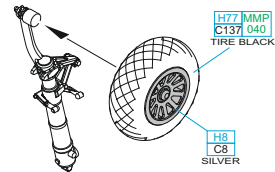

H

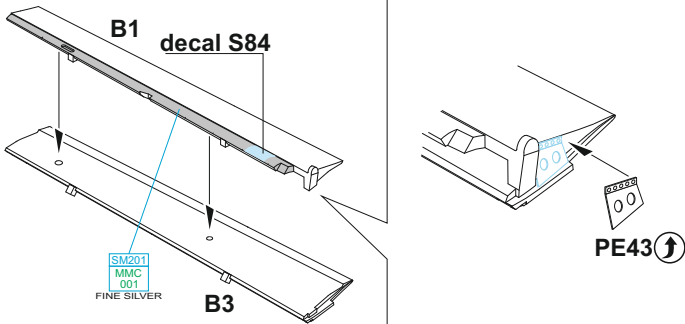

I

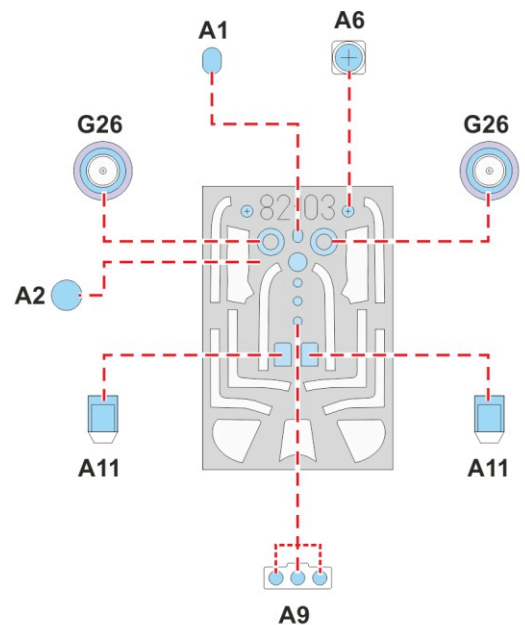
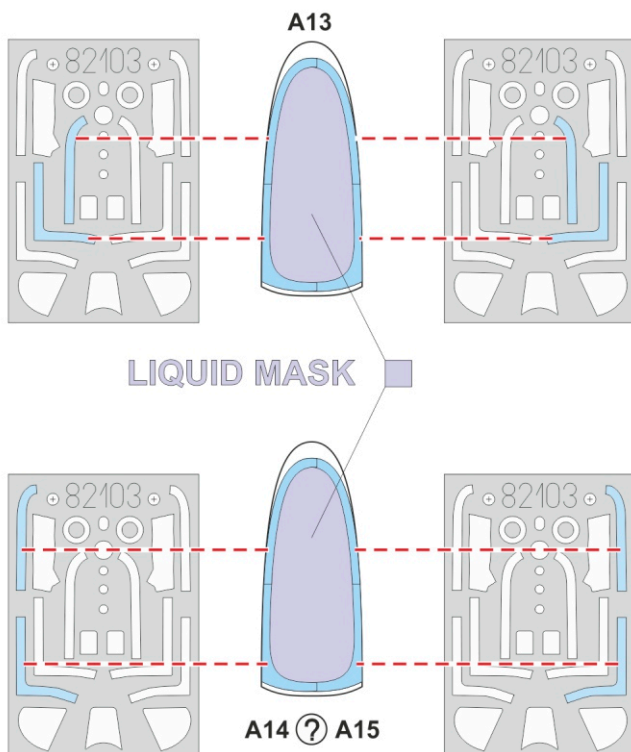
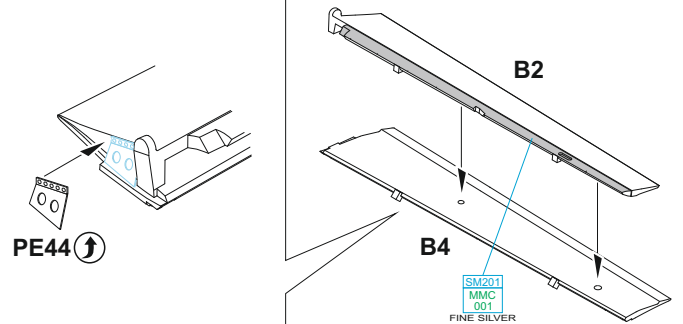

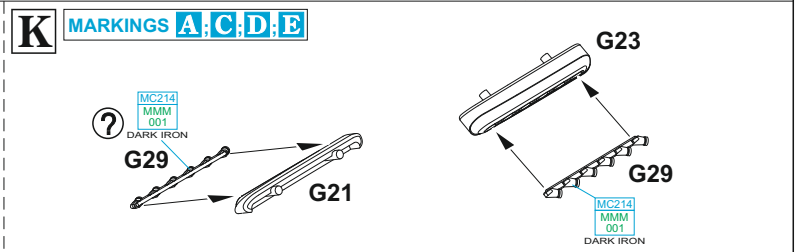
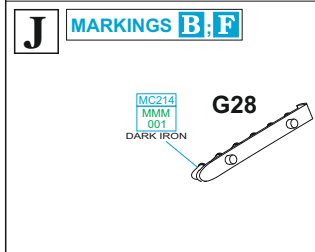
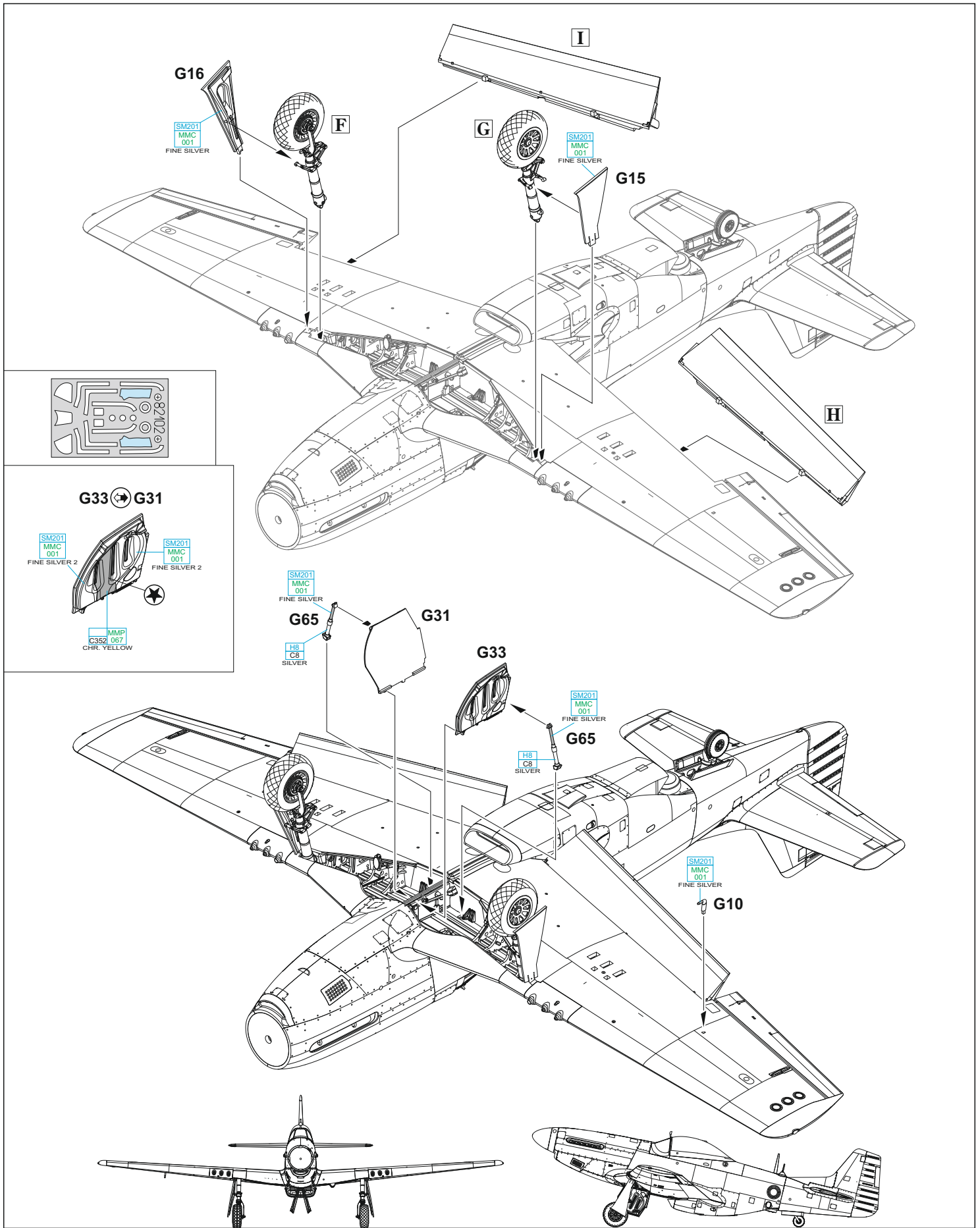

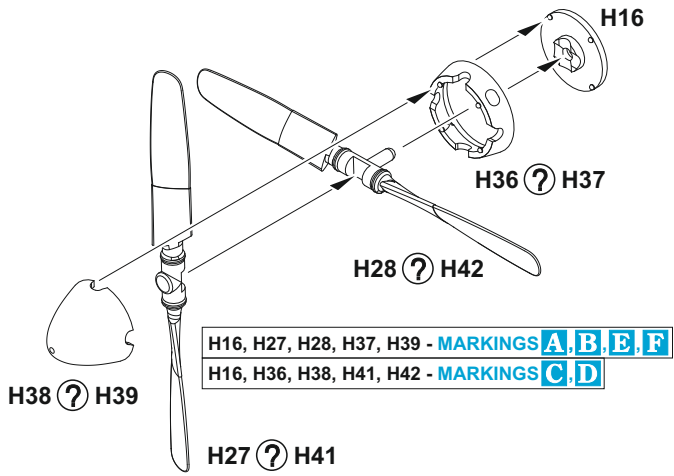
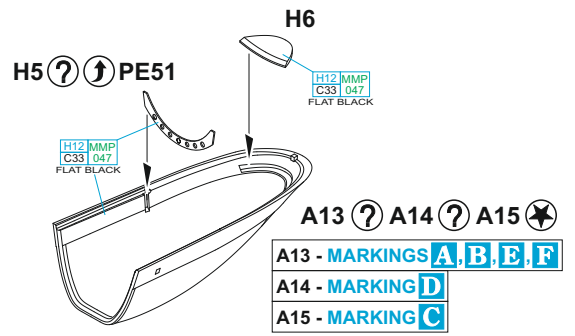
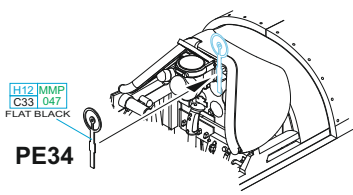
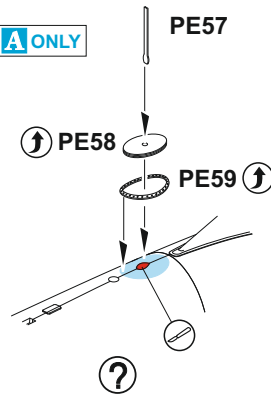
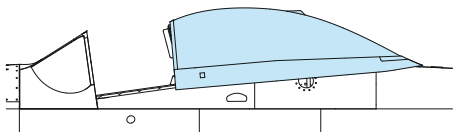
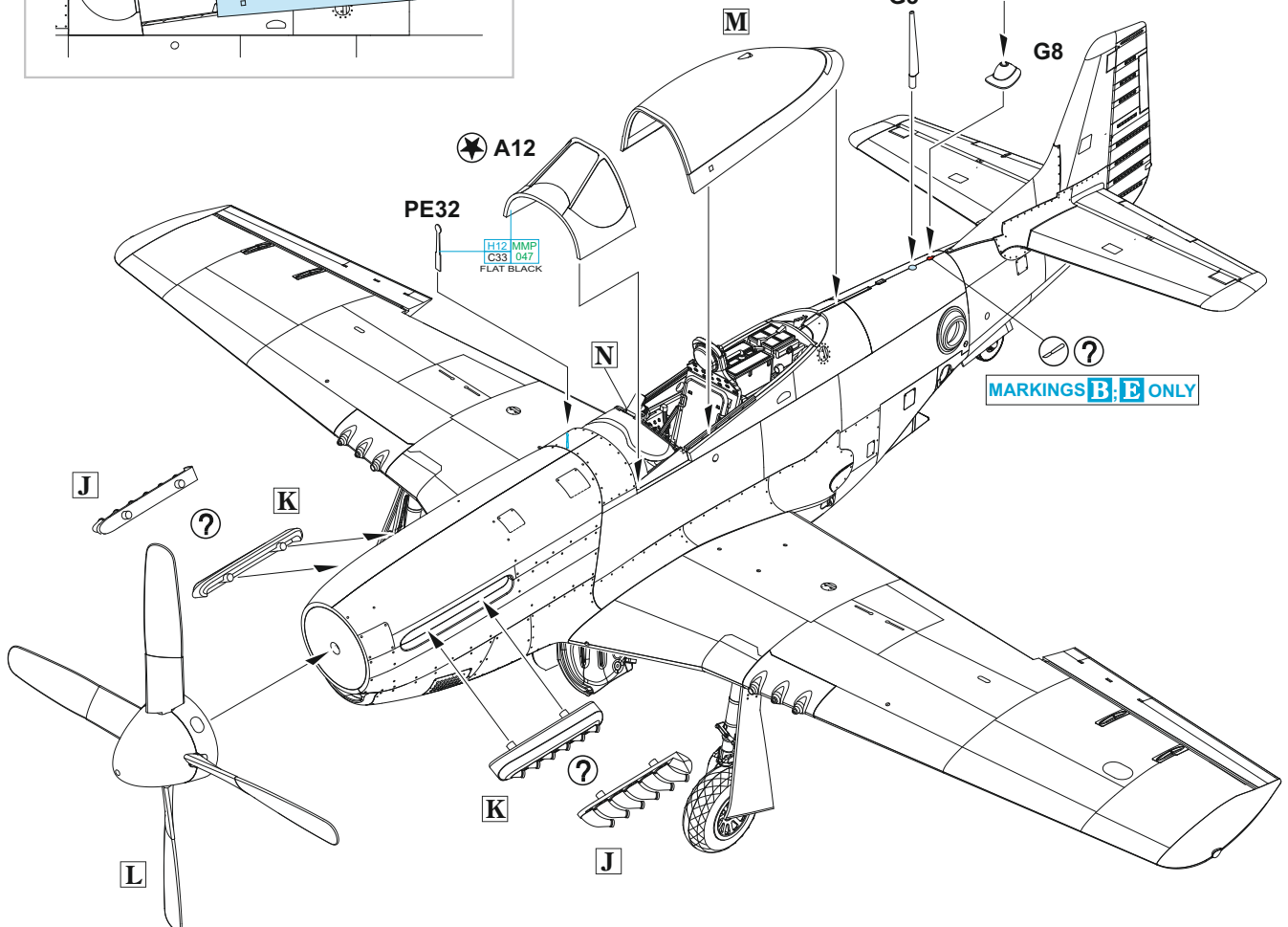
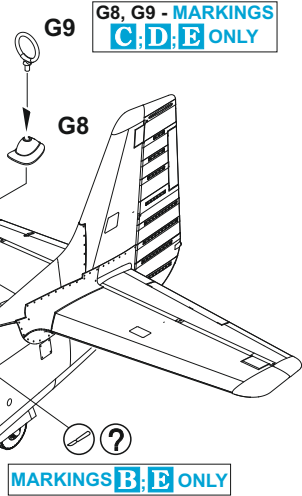
**L****M****N**PE57, 58, 59 - MARKING **A** ONLY**OPEN CANOPY POSITION**G8, G9 - MARKINGS **C, D, E** ONLY

2 pcs. MARKINGS C, D, E ONLY

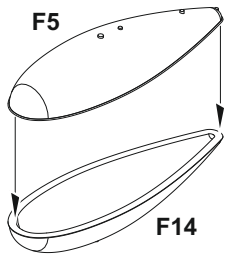

O MARKING A ONLY

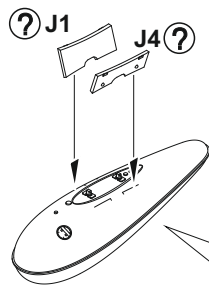

2 pcs.

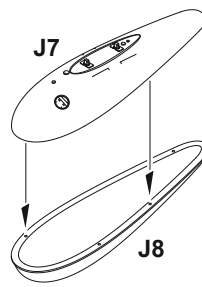

P MARKING A ONLY

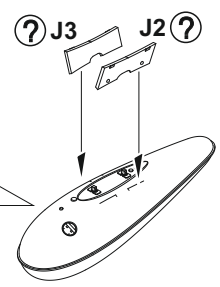

?

Q

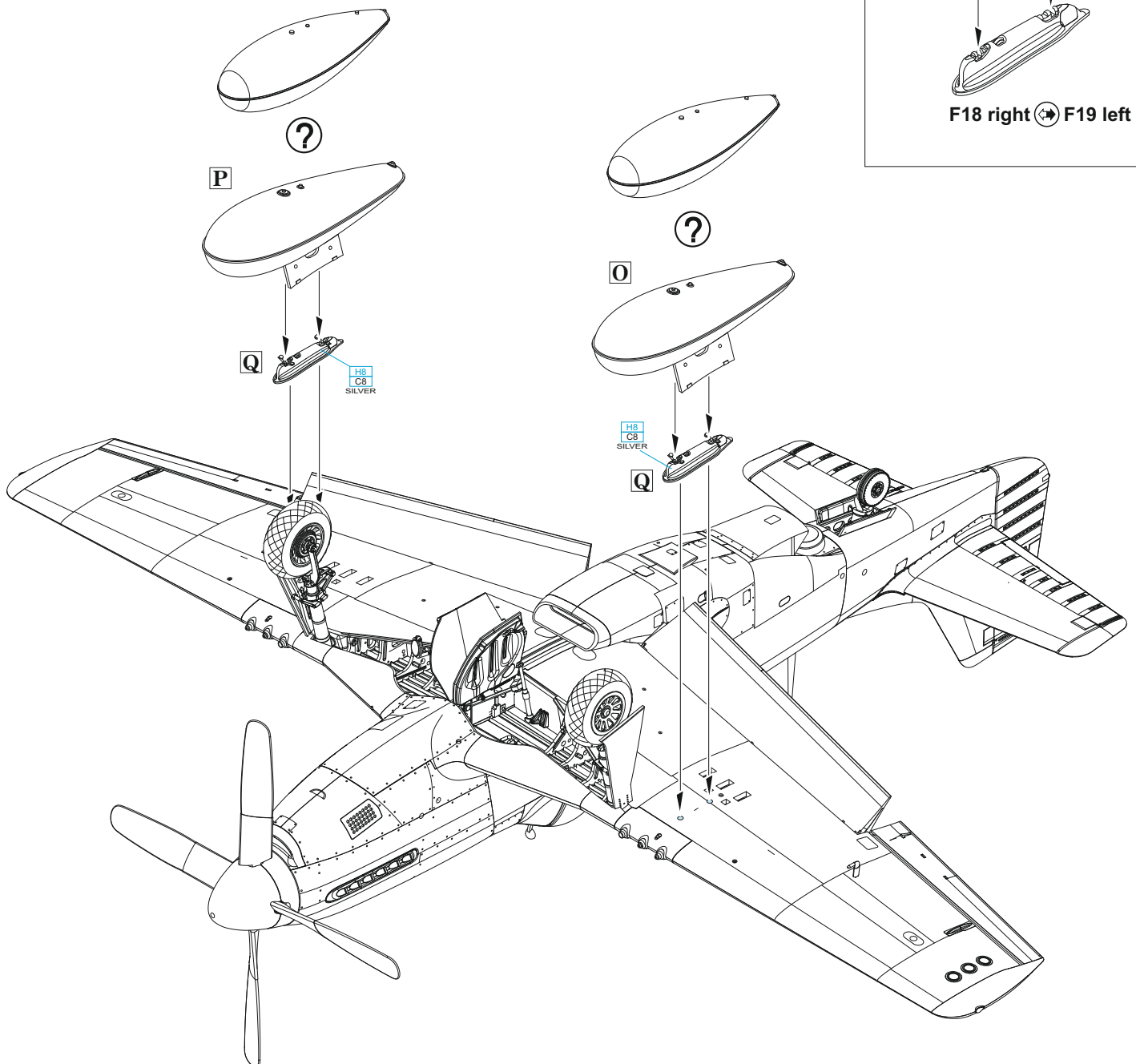
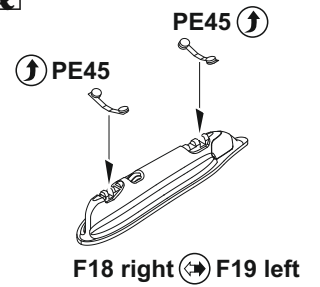

# A F-6D-15, 44-14874, flown by Lt. John E. Jacoby, 82nd TRS, 71st TRG, 5th AF, Johnson Field, Japan, September 1945

Since November 1944, 82nd Tactical Reconnaissance Squadron, within 71st TRG, participated in reconnaissance missions over Philippines island of Luzon, ground units' support, photographing and bombing of the airports on Formosa and China. Its next base became the island of Ie shima from where they were flying sorties over the Japanese island of Kyushu. Since the deployment over the Philippines until the middle of June 1945 the unit was commanded by Capt. William Shomo, probably the most famous F-6D pilot. At the end of hostilities, the unit was transferred to Irumagawa airbase on the Tokyo outskirts. The squadron deployed aircraft nr.54 from the very beginning of the combat on Philippines and she remained in the unit inventory even after the end of War and served as a part of occupying forces on Japanese territory. The aircraft appearance during its service changed significantly. At the beginning of its service the aircraft carried only number 54 on the vertical tail surface, later the black stripes were added to the fuselage and wings, anti-glare panel was repainted black and the propeller spinner sported several versions of the coloration. Inscriptions on the fuselage nose are also documented in two different layouts. There is an 82nd TRS marking on the port side of the fuselage, most probably applied after the end of War.

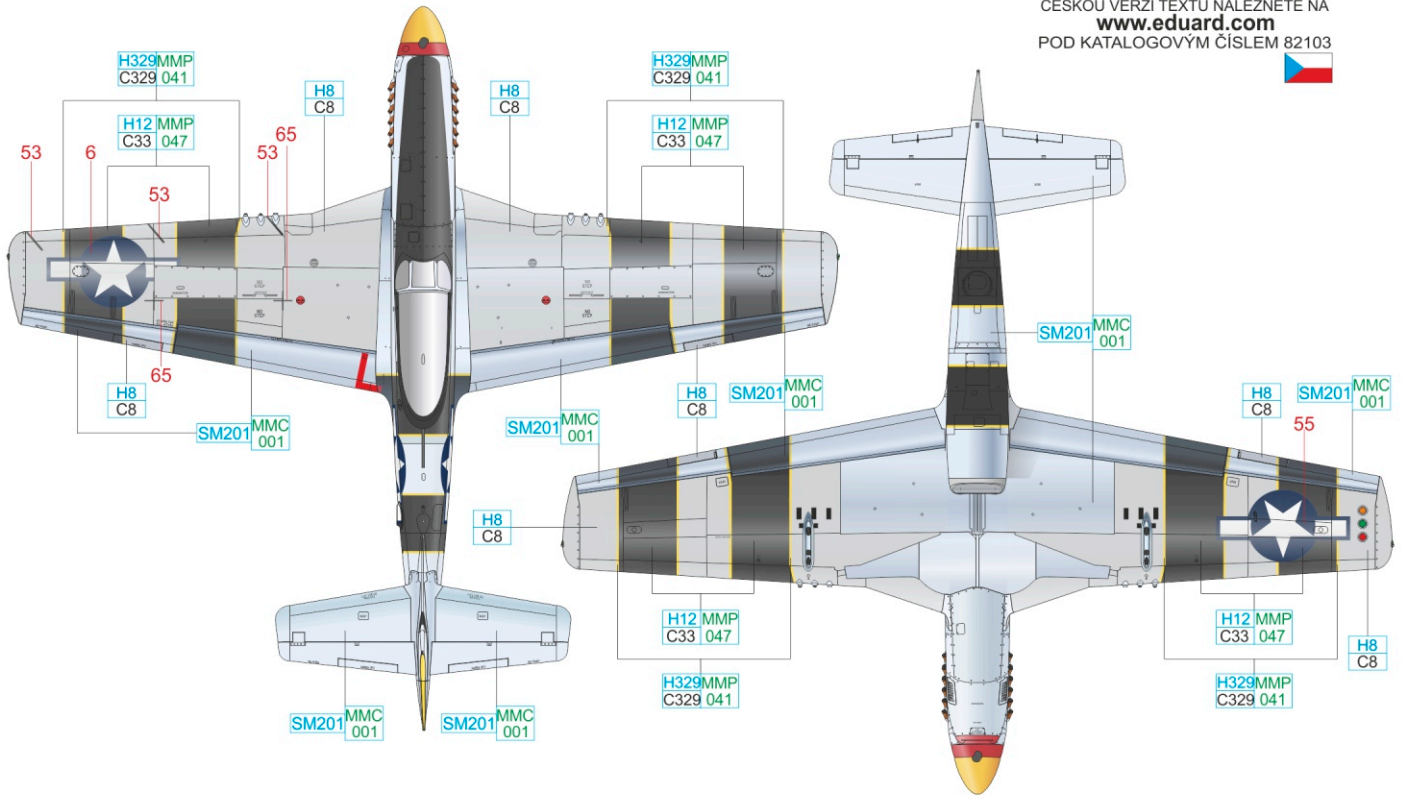
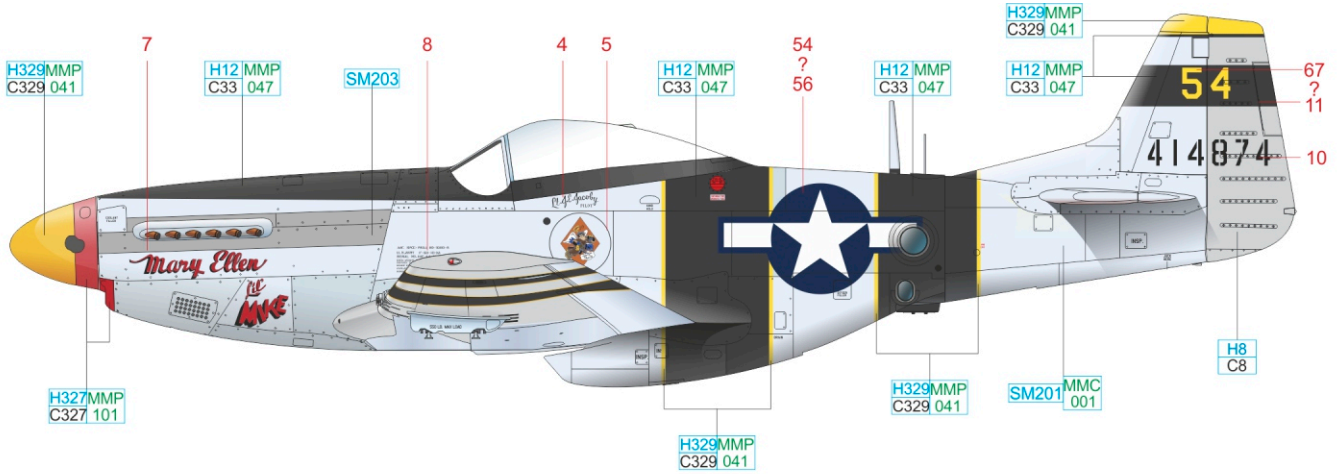

ČESKOU VERZI TEXTU NALEZNETE NA [www.eduard.com](http://www.eduard.com)

POD KATALOGOVÝM ČÍSLEM 82103

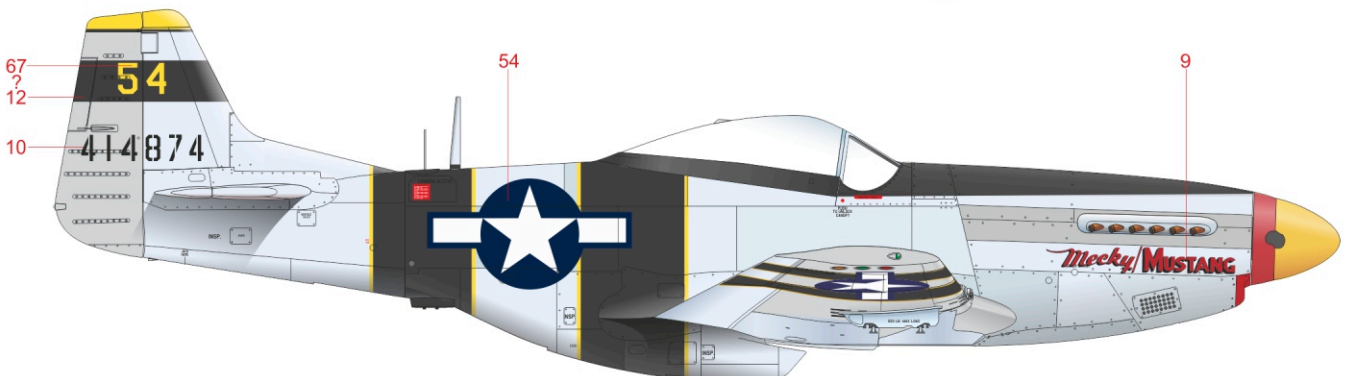

BLACK	H12 MMP C33 047	RED	H327MMP C327 101	YELLOW	H329MMP C329 041
SUPER FINE SILVER	SM201 MMC 001	SUPER IRON	SM203	SILVER	H8 C8

# B F-6D-10, 44-14699, flown by Lt. Clifford S. Slonneger, 109th TRS, 67th TRG, 9th AF, Gosselies, Belgium, 1945

67th TRG history begins in September 1941 when it was formed in Louisiana as the Observation Group and its first task were anti-submarine patrols alongside the United States East Coast which it carried out until March 1942. Transfer to the Great Britain followed in August 1942, where the training continued. In October 1943 it was ordered under the 9th Air Force command, renamed to 67th Tactical Reconnaissance Group and 107th and 109th TRS under its command were equipped with F-6 Mustang. 109th TRS, in which ranks Lt. Slonneger flew 54 missions, operated this type on photo-reconnaissance sorties until the end of hostilities. After the War, the unit was transferred back to the United States in August 1945 and disbanded in March the following year. F-6D from this unit often had the oval window on the side of the fuselage covered. It is highly probable that it was the case of the aircraft named Shady Lady.

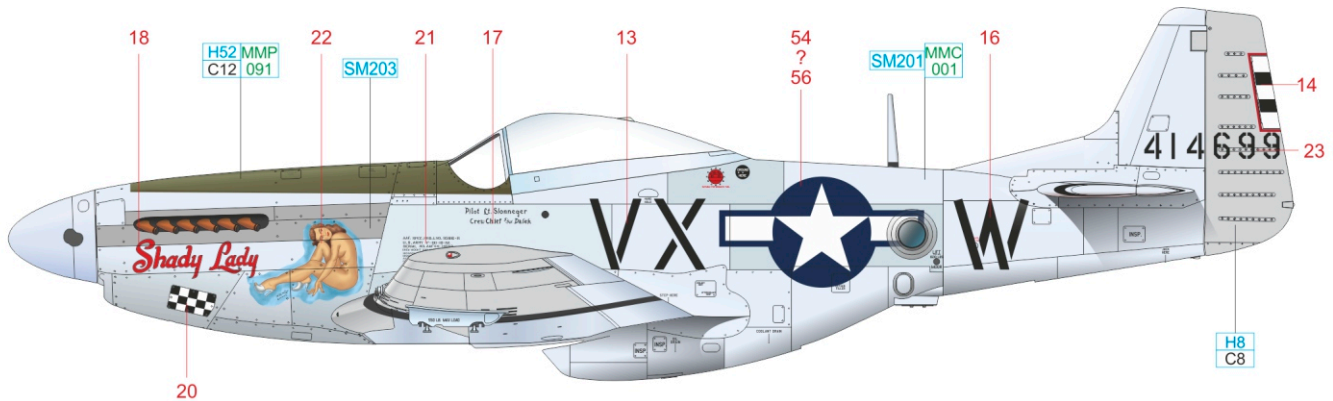

ČESKOU VERZI TEXTU NALEZNETE NA  
[www.eduard.com](http://www.eduard.com)  
 POD KATALOGOVÝM ČÍSLEM 82103

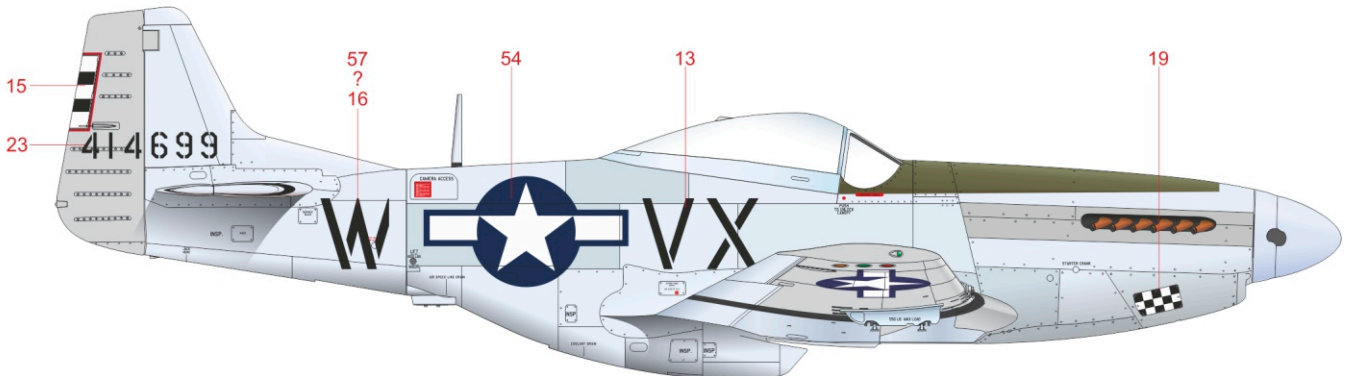
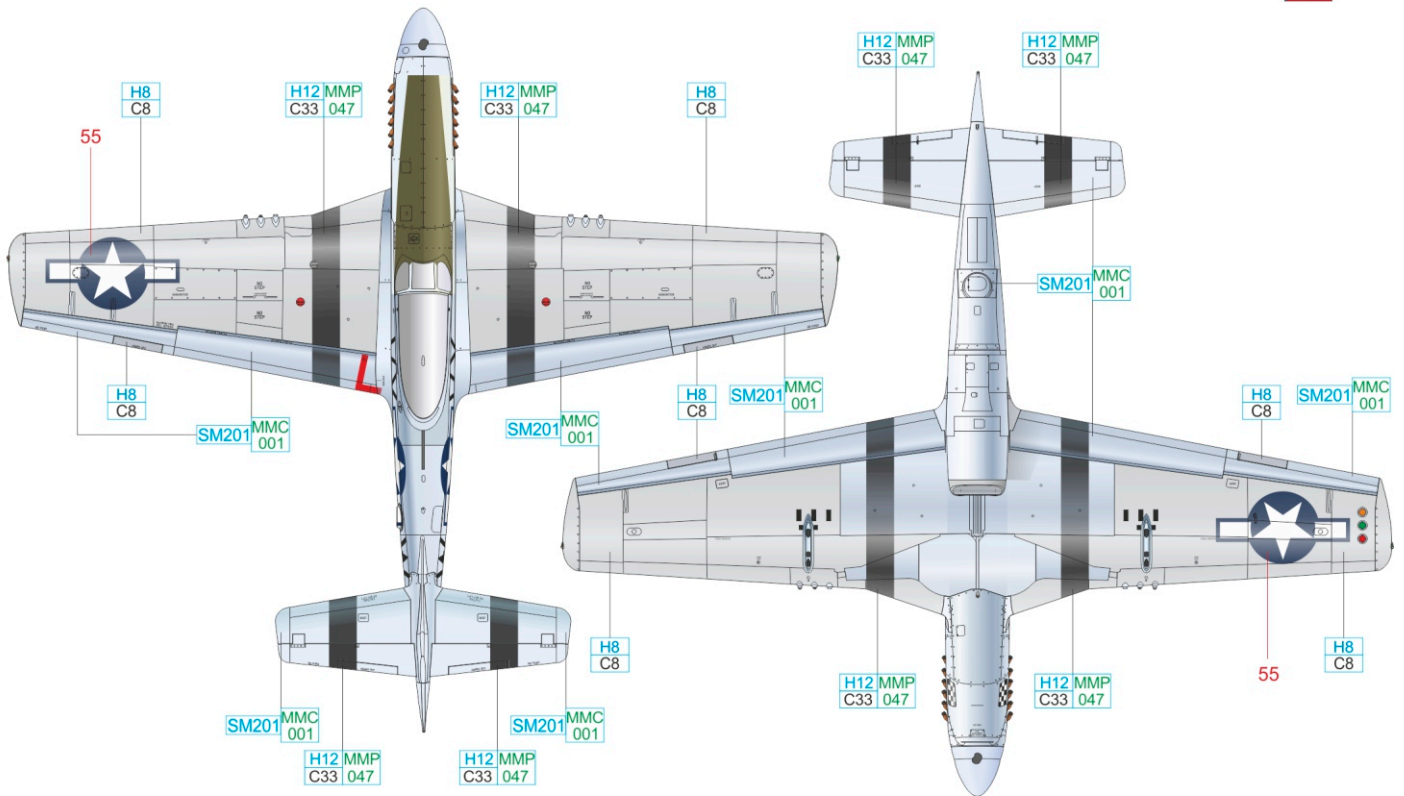

OLIVE DRAB	H52 MMP C12 091	BLACK	H12 MMP C33 047
SUPER FINE SILVER	SM201 MMC 001	SUPER IRON	SM203
		SILVER	H8 C8

# C F-6K-10, 44-12223, 118th TRS, 23rd FG, 14th AF, Chengkung, China, 1945

118th Squadron was activated in March 1941 at Jacksonville airbase in Florida from where it flew anti-submarine sorties. In August 1942 it was relieved from these duties and started the preparations for the overseas service. In August 1943 it was redesignated to 118th TRS, its was assigned to China-Burma-India Theatre for which specifics it was being prepared the following year. At the beginning of the year the unit was transferred from the USA to India. Between May and June 1944 the unit supported the ground units, attacked the traffic centers, warehouses, troops gathering points, airports, and other ground targets. Initially the unit was equipped with P-40s, later it received P-51Ds including several reconnaissance F-6. 118th TRS aircraft recognition marking was black lightning outlined in yellow painted on the sides of the P-51 fuselage. In smaller size these markings were also applied on the wing tips, vertical and horizontal tail surfaces. The aircraft christened SNOOPER carried the lightnings on the fuselage sides only, the rest of the marking was not applied.

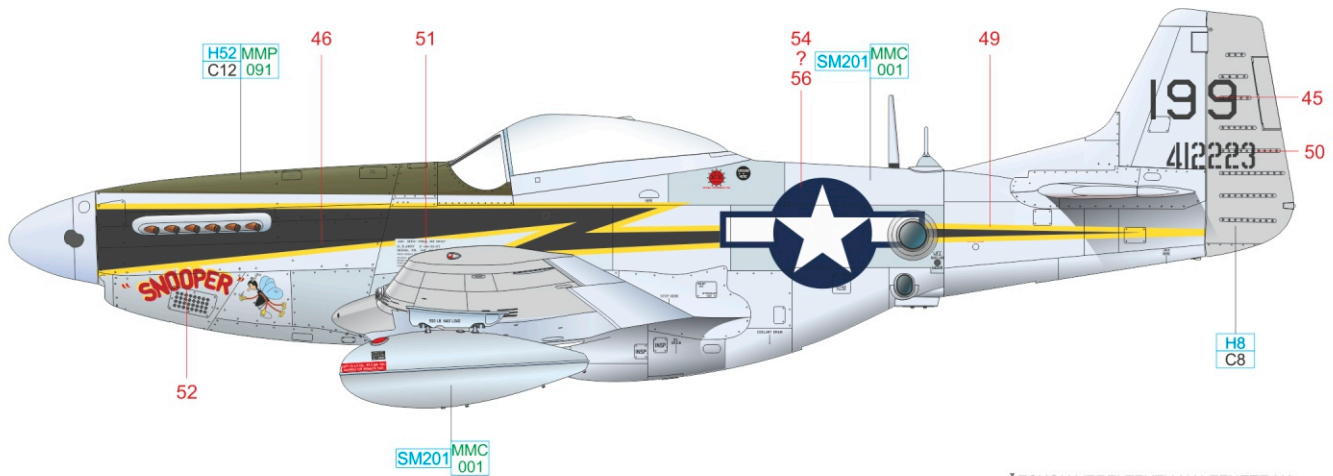

ČESKOU VERZI TEXTU NALEZNETE NA  
[www.eduard.com](http://www.eduard.com)  
 POD KATALOGOVÝM ČÍSLEM 82103

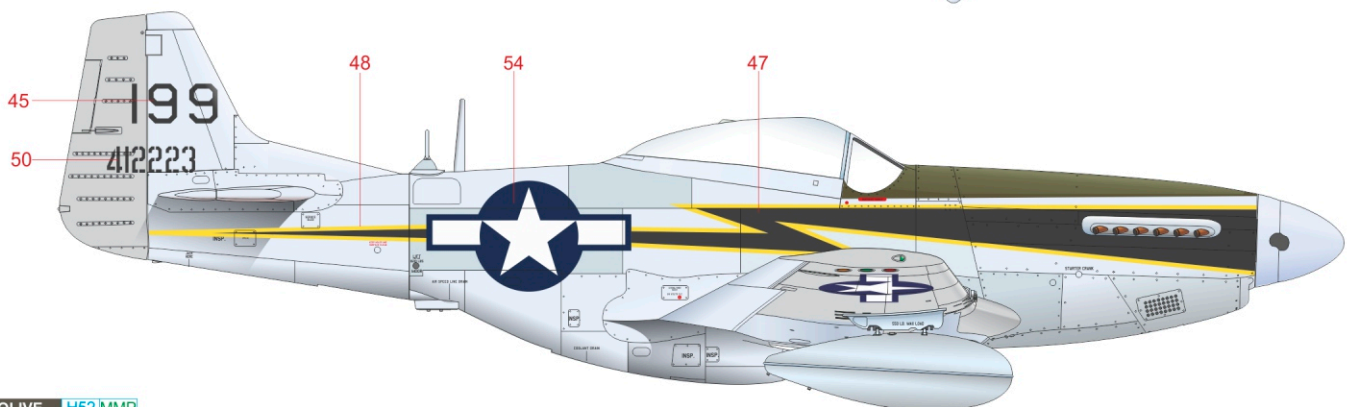
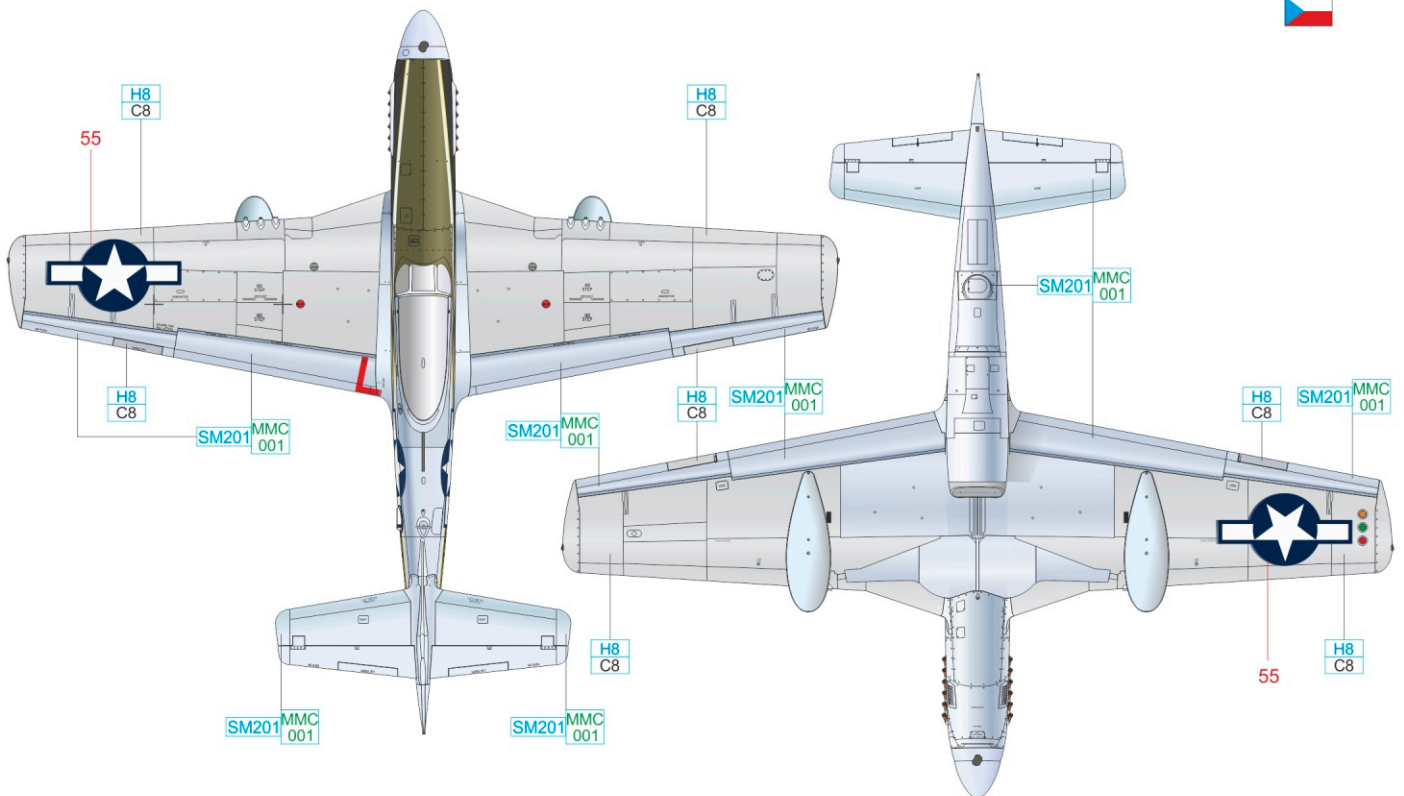

OLIVE DRAB	H52 MMP C12 091	SILVER	H8 C8
SUPER FINE SILVER	SM201 MMC 001		

# D F-6K-15, 75th FS, 23rd FG, 14th AF, Luliang Airfield, China, 1945

After the American Volunteer Group flying P-40s in combat over the Chinese territory, known as The Flying Tigers, was disbanded, most of its pilots joined 75th FS ranks. Same as its sister 118th TRS, also under 23rd FG command, 75th FS, equipped with P-51Ds engaged in ground units' close support, attacks on the traffic centers, warehouses, troops gathering points, airports, and other ground targets. To verify the results of such combat missions 23rd FG squadrons were equipped with several reconnaissance F-6. It was always a few aircraft only. Reconnaissance F-6K christened Pack's Hack flying with this unit had the rear part of the fuselage including the tail surfaces painted black same as all the airplanes of the 75th FS and simplified unit marking sprayed on both sides of the fuselage under the canopy just in black paint directly on the metal surface.

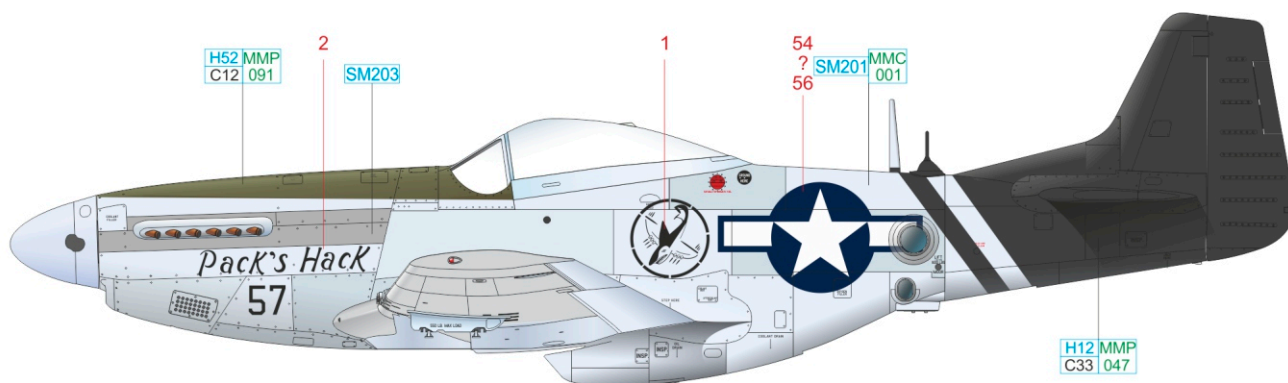

ČESKOU VERZI TEXTU NALEZNETE NA  
[www.eduard.com](http://www.eduard.com)  
 POD KATALOGOVÝM ČÍSLEM 82103

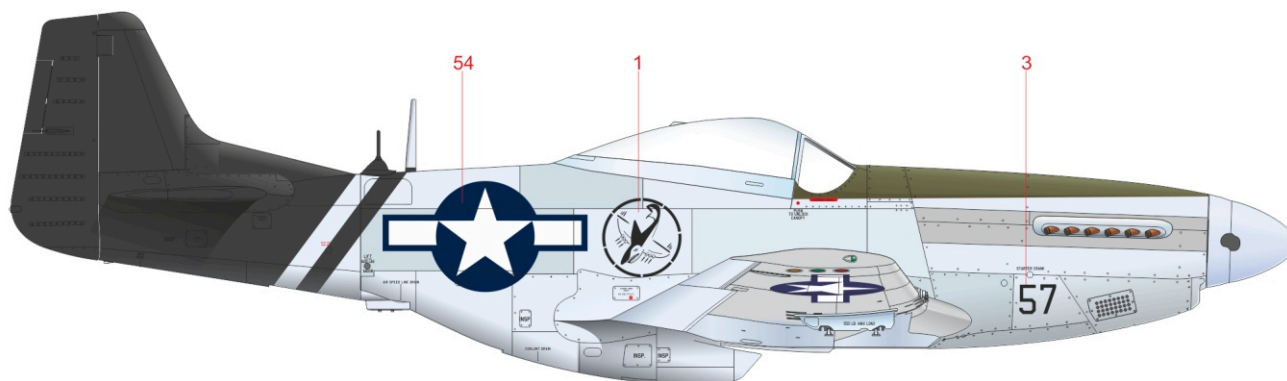
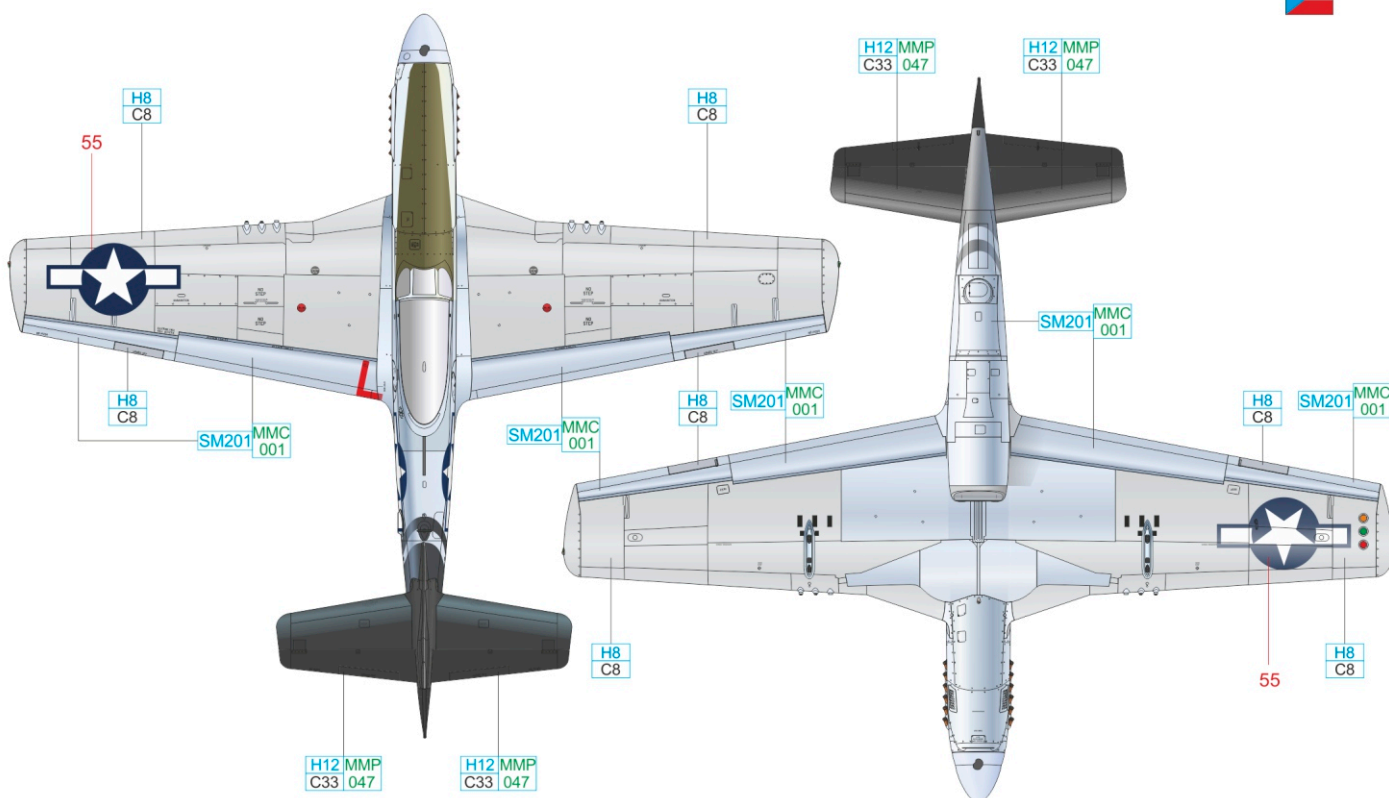

OLIVE DRAB H52 MMP C12 091 BLACK H12 MMP C33 047

SUPER FINE SILVER SM201 MMC 001 SUPER IRON SM203 SILVER H8 C8

eduard

# E F-6D-15, 44-15417, flown by Lt. Edwin H. Pearle, 2nd FS, 2nd ACG, Cox's Bazar, India, Spring 1945

2nd Air Commando Group, equipped with P-51, C-47 and L-5 aircraft relocated from the United States to India during the fall 1944 and its main task was support of the ground units operating on the territory of China and Burma, including the resupplying the units with armament and equipment. Part of this group were two fighter squadrons - 1st FS and 2nd FS. Each one was equipped with 22 P-51D fighters and three reconnaissance F-6s. Both 2nd ACG squadrons were mainly busy with ground units' support but in the spring 1945 pilots of the both squadrons organized several extremely long distance attacks against the Japanese air bases during which they claimed 60 enemy aircraft destroyed and 40 probably destroyed or damaged. Lt. Pearle contributed with one damaged bomber to this score. 2nd FS recognition marking was a propeller spinner with natural metal tip and base in black paint. Rebel Gal, same as several other airplanes from this unit, carried the unit marking on the fuselage nose in the form of an eagle carrying machine gun in his claws. The fuselage and wings sported 2nd ACG markings in the form of lightnings.

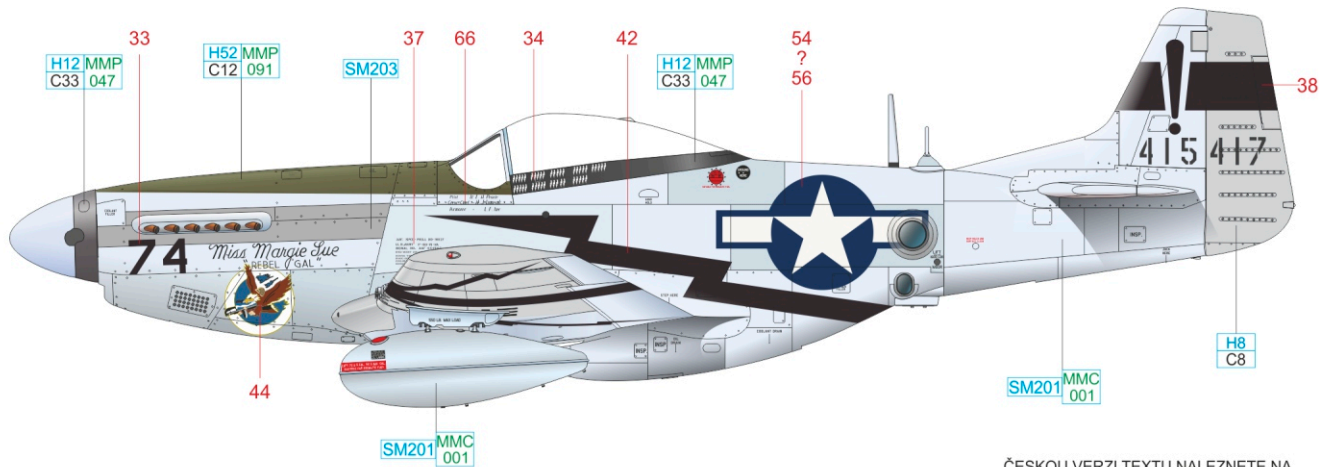

ČESKOU VERZI TEXTU NALEZNETE NA [www.eduard.com](http://www.eduard.com)  
POD KATALOGOVÝM ČÍSLEM 82103

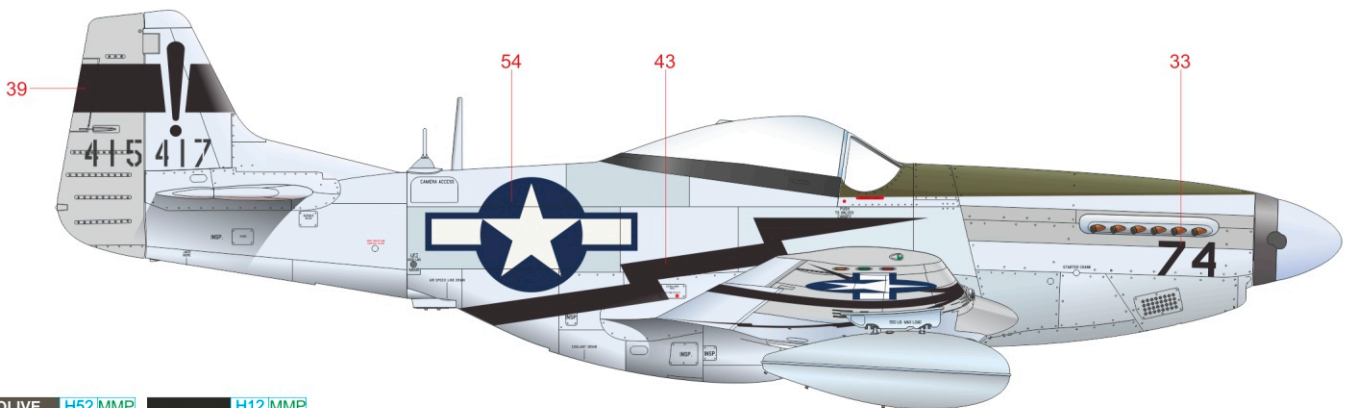
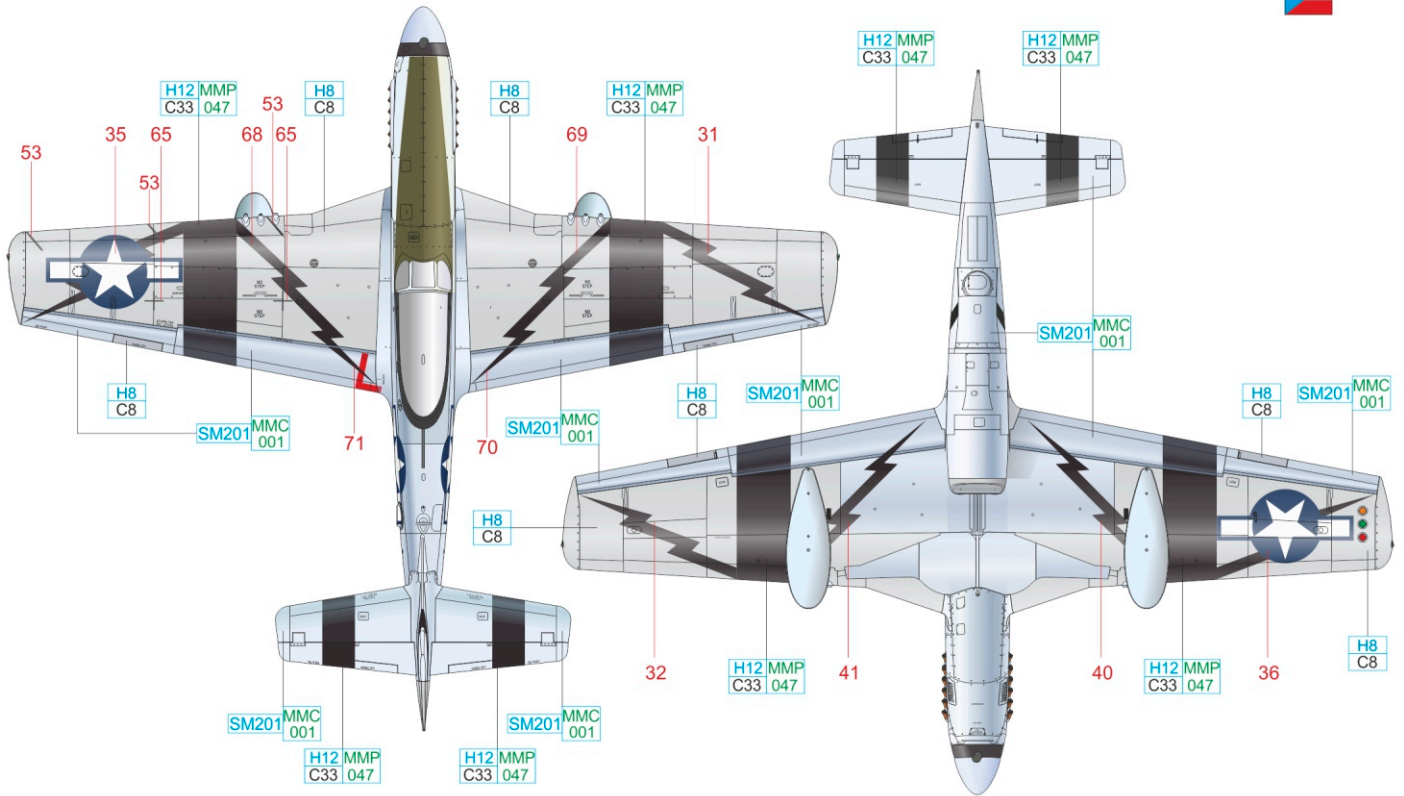

OLIVE DRAB	H52 MMP C12 091	BLACK	H12 MMP C33 047
SUPER FINE SILVER	SM201 MMC 001	SUPER IRON	SM203
		SILVER	H8 C8

# F F-6D-10, 44-14659, 111th TRS, 68th TRG, 12th AF, Fürth, Germany, July 1945

111th Observation Squadron, part of the Texas Air National Guard, was after the attack on Pearl Harbor dispatched to the Mexican border where it was guarding the border. As soon as February 1942 it was ordered under 68th OG command and started preparations for the service in Europe. In 1942 the unit with its P-39s relocated to the Great Britain as a part of the preparations for the invasion to Algiers. In 1943 the unit was renamed to 111th TRS, equipped with F-6A and B aircraft and participated in the Operation Husky (invasion of Sicily), Operation Dragoon (invasion of the Southern France) and further campaigns of the ground forces through the Southern Europe. After the end of the War the unit returned into the ranks of the Texas Air National Guard. It is still active nowadays equipped with MQ-1B Predator.

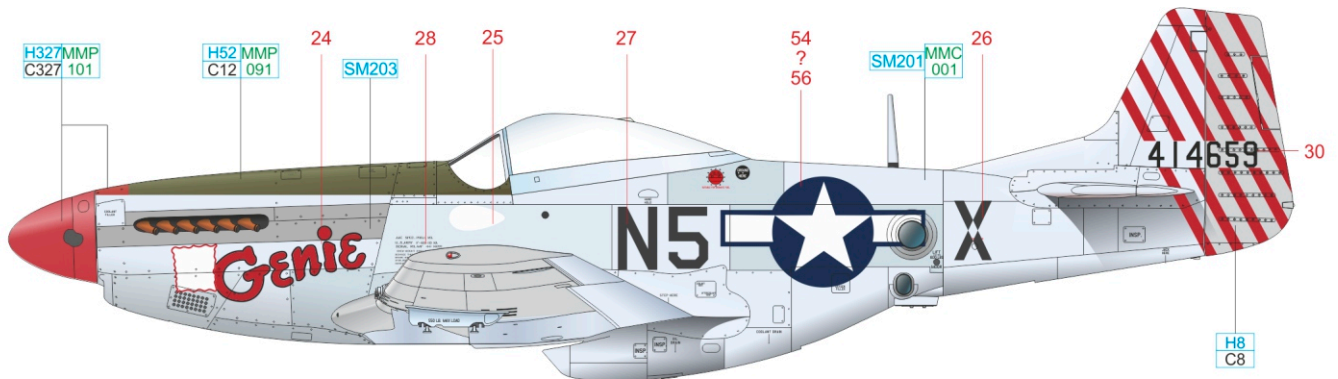

ČESKOU VERZI TEXTU NALEZNETE NA  
[www.eduard.com](http://www.eduard.com)  
 POD KATALOGOVÝM ČÍSLEM 82103

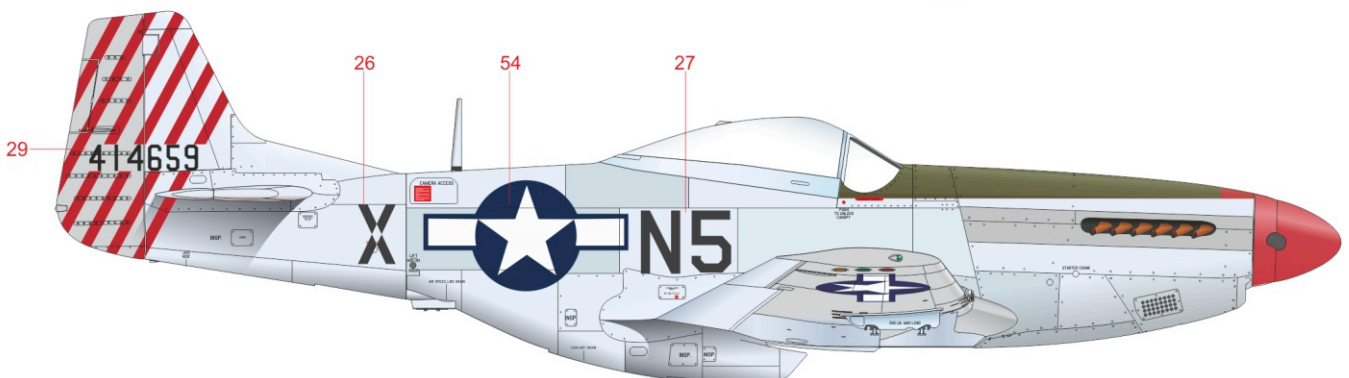
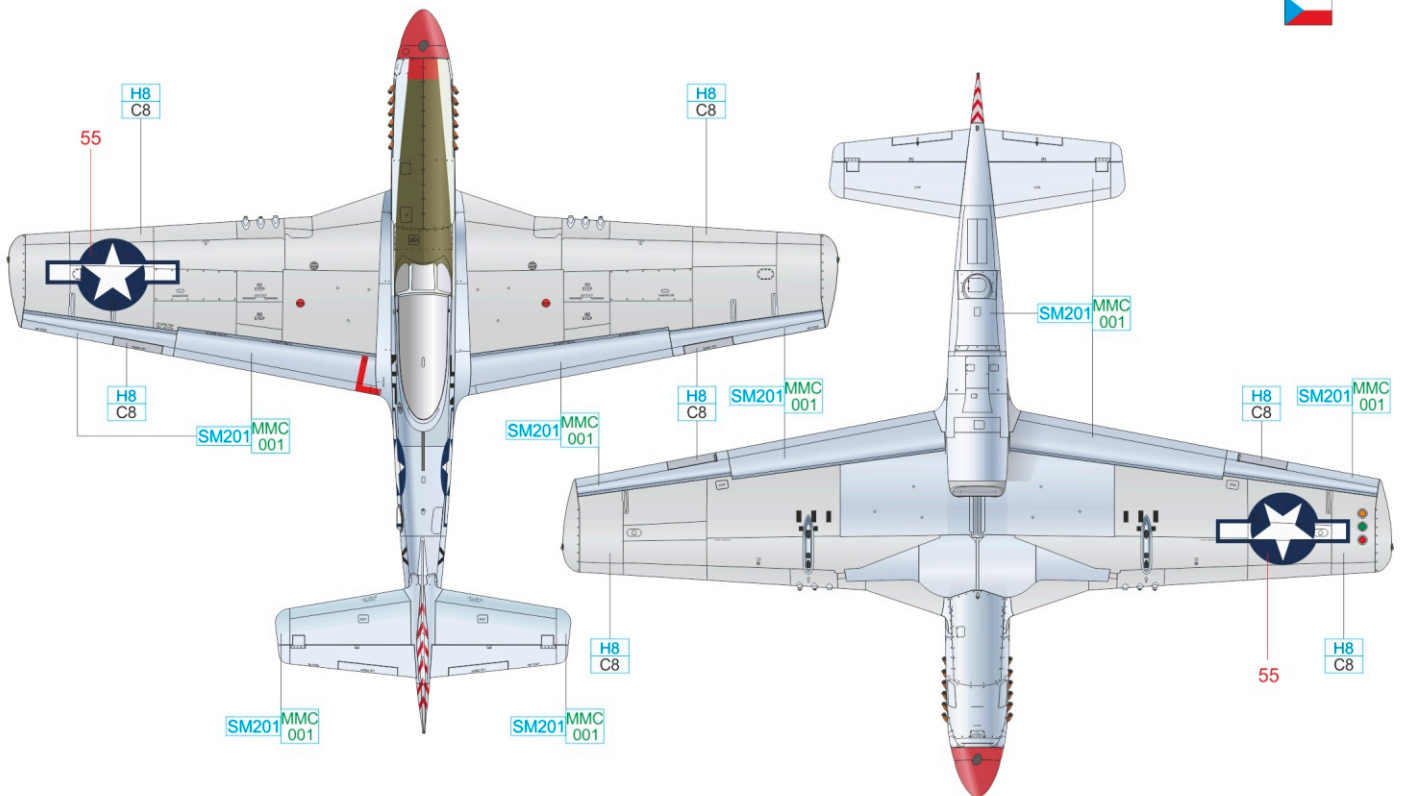

OLIVE DRAB H52 MMP C12 091 RED H327MMP C327 101

SUPER FINE SILVER SM201 MMC 001 SUPER IRON SM203 SILVER H8 C8

# F-6D/K ALUMINIUM LACQUER PAINTED AREAS

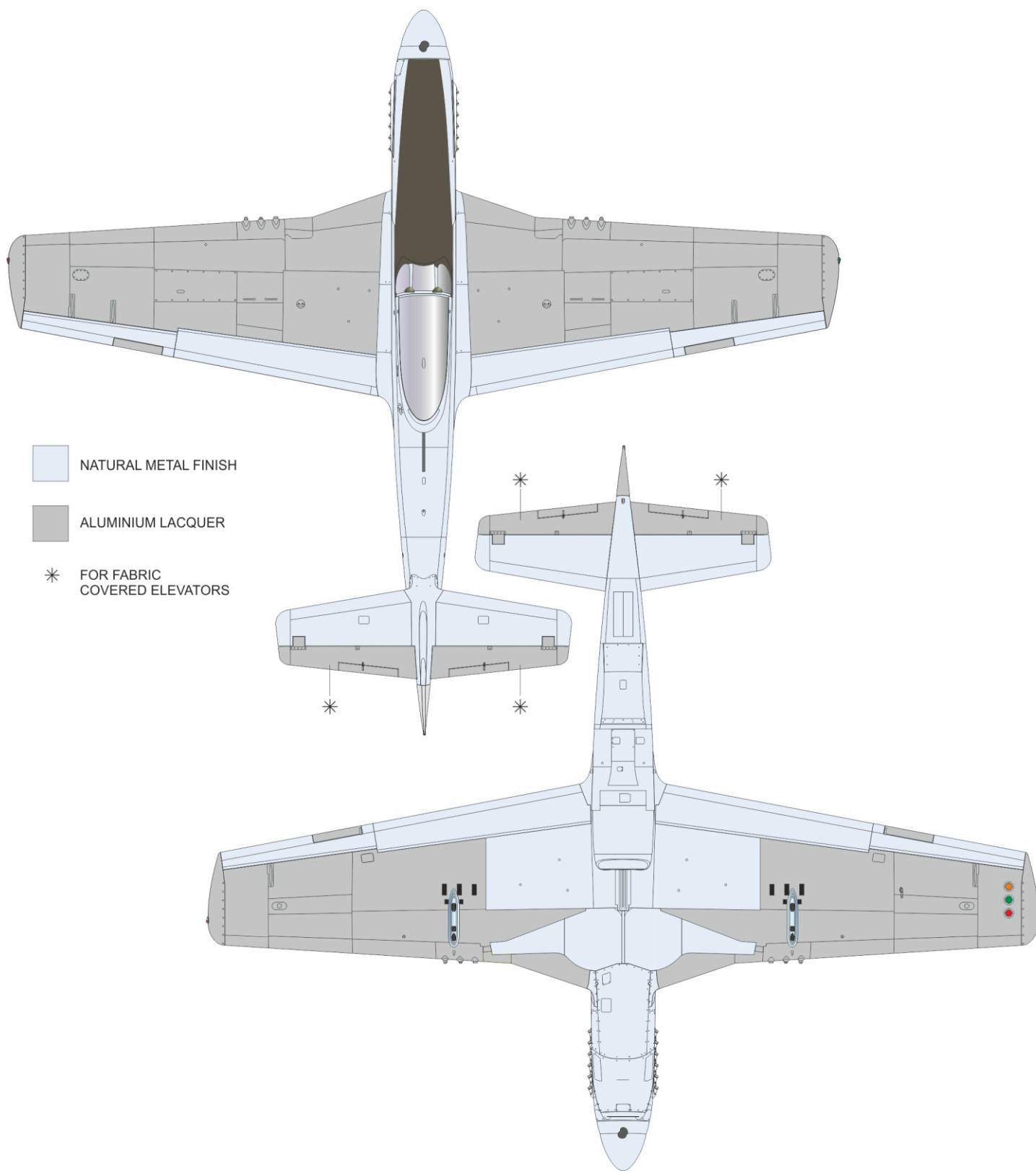

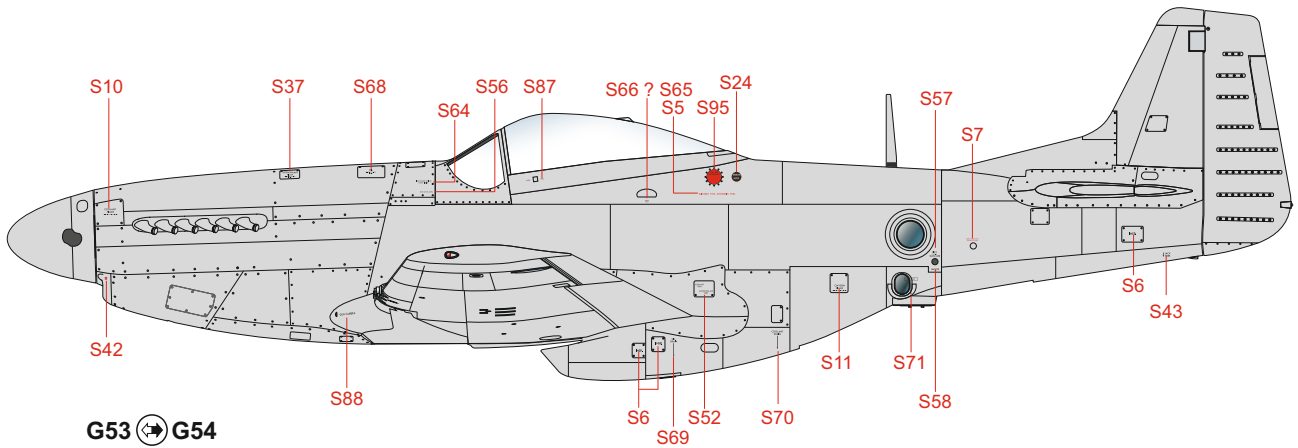

G53 G54

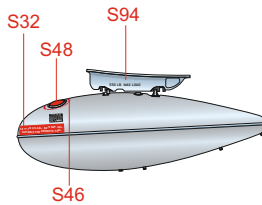
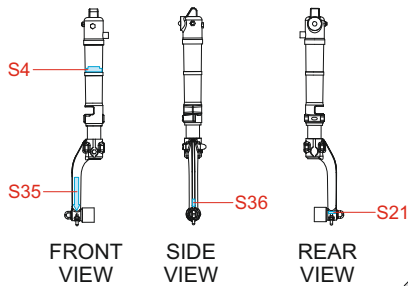

Parts No. H27, H28

H329 MMP  
C329 041  
H12 MMP  
C33 047

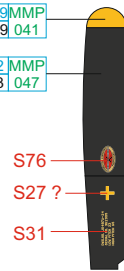

Parts No. H41, H42

H329 MMP  
C329 041  
H12 MMP  
C33 047

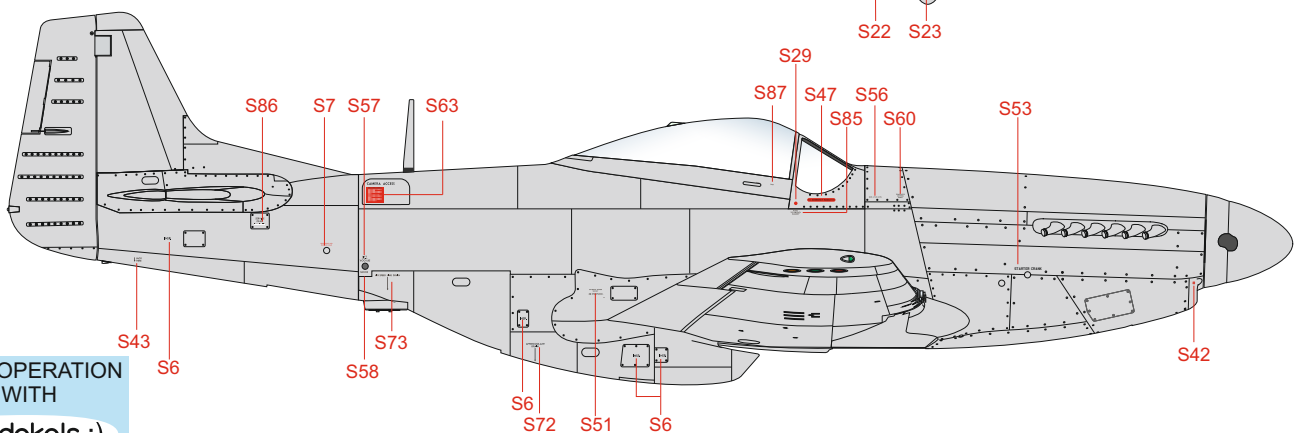
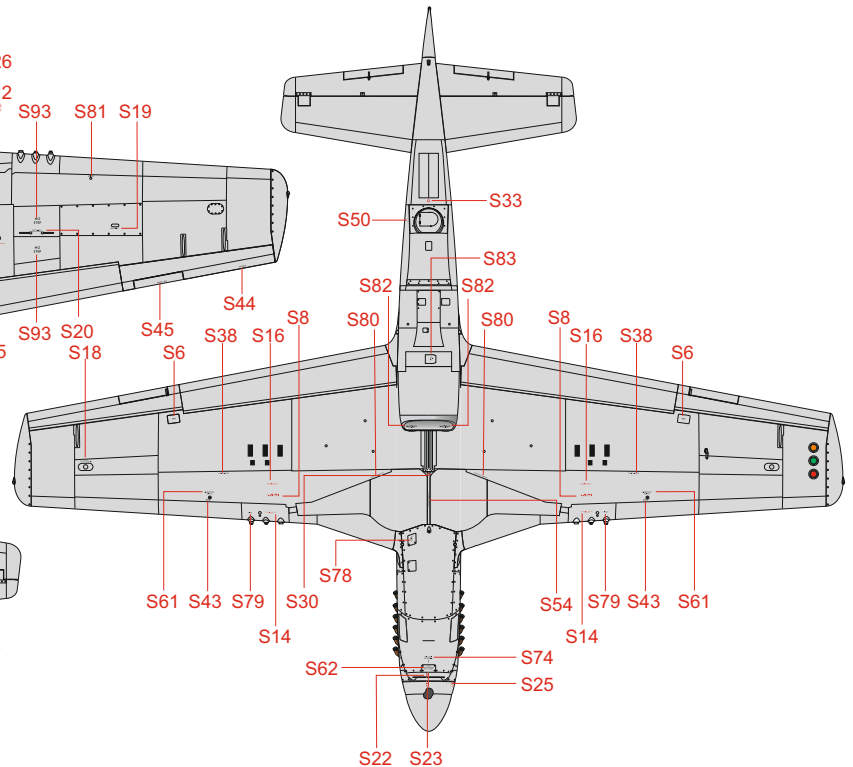
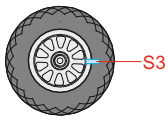
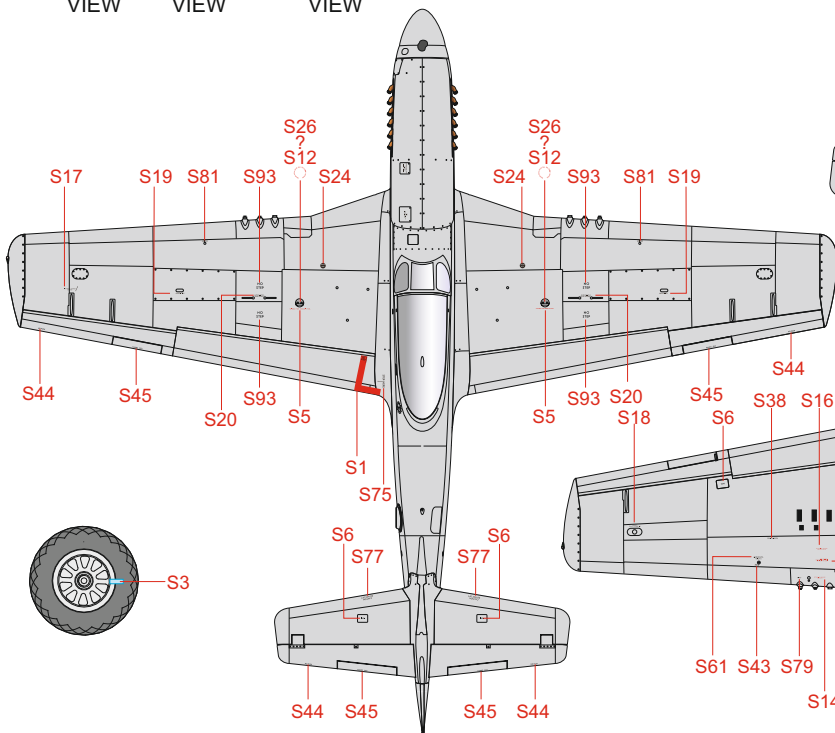
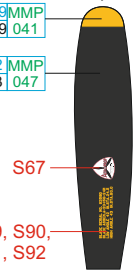

IN COOPERATION WITH  
fündekals :)

eduard