

P-51B Mustang™ w/ dorsal fin

eduard

1/48 Scale Plastic Model Kit



Produced under license

Boeing, P-51 Mustang, their distinctive logos, product markings and trade dress are trademarks of The Boeing Company.

ProfiPACK edition



item No. 82108

The P-51 Mustang is one of the best fighters of all the time and although American design, it owes a lot to the Great Britain for its genesis.

It was in 1940, when British Buying Committee asked North American Aviation (NAA) to build the Curtiss P-40s for the RAF. NAA president James Kindelberger offered Britons development of much better plane instead. Britons agreed and the design team led by chief designer Edward Schmued, who was German immigrant with Austrian roots, commenced their work. The preliminary design was approved on May 4, 1940, final assembly and engine installation began on September 9 (just 127 days after approval) and the first flight of the NA-73X prototype followed on October 26.

Innovative fighter

The Allison V-1710-39 liquid cooled in-line engine rated at 1,100 HP was chosen for the new fighter and the designers did their best to create as narrow and sleek fuselage as possible to lower the drag. For the same reason they decided to use an innovative laminar flow airfoil reducing drag, but, on the other hand, requiring smooth surface to work properly. That necessitated to putty and sand the leading area of the wing. Another design novelty was the radiator belly under the fuselage, which also developed additional thrust thanks to the Meredith effect. Armament consisted of two guns in the nose and four in the wings, all of them .50 caliber Brownings (the Mk. Ia variant had four 20mm cannons). Britons chose the name Mustang for the new aircraft, later adopted by USAAF as well. The RAF received first Mustangs Mk.I in October, 1941. The performance was found satisfactory, as they were faster than Spitfires Mk.V and had more than double the range. On the other side, the Allison engine reached its maximum power output at 11,800 ft (3597 m) because of its one-stage supercharger. Above this level the engine performance decreased rapidly. As the aerial combats occurred much higher, the RAF decided to use their Mustangs in the reconnaissance role and US Army Air Corps, interested in the new type as well (but bound to the contracts to buy P-40s, P-39s and P-38s), asked the NAA to convert the Mustang to dive bomber variant with wing dive brakes (A-36).

Merlin magic

To solve the high-altitude lack of power, the work had begun in Britain to fit the Mustang with the double-stage supercharger Merlin engine. The trials of the Mustang X prototype revealed the level speed of 433 mph (697 km/h) at 22,000 ft (6700 m), thus 100 mph (161 km/h) faster than Mustang Mk. I. As it was obvious this is the way to further develop the Mustang, NAA started the work using Packard V-1650-1 (license built Merlin 61). As the

Packard unit sported some design changes, it was not possible to retrofit Mustangs with original Merlins. The need for intercooler for two-stage supercharger necessitated bigger radiator duct. Another change included removal of the fuselage guns. The production started at the Inglewood plant as P-51B on May and at the new production line at NAA Dallas plant as P-51C in August, 1943. Supplies to RAF continued as Mustang Mk. III. After just handful of new Mustangs were produced, the then commander of US Air Forces in Europe General Henry Arnold asked for even greater range. NAA responded with additional 85-gallon tank installed behind the pilot's seat.

The P-51B/C were great fighters but lacked backward visibility and suffered with gun jamming. The RAF found particle solution of the visibility issue with a „Malcolm Hood“ semi-bubble canopy, but the design team of NAA decided to rework the Mustang again. The main change was the bubble canopy with lowered rear fuselage. The wing was reworked to accommodate six .50 cal guns and the new arrangement of ammo chutes eliminated the jam problem. Together with some other changes, the new P-51D, the „Definitive“ Mustang, was born at the end of 1943 and the production started at both Inglewood (serials with -NA suffix) and Dallas (-NT) plants. Due to the short supply of the Hamilton Standard alloy propellers used on Merlin powered P-51s, the Dallas Factory was fitting their Mustangs with steel Aero product ones with hollow blades as the P-51K.

The P-51D/K became the true ruler of the skies, serving as the escort and patrol fighter, and also in ground attack or reconnaissance role (F-6 conversion). In total, 8,102 units of P-51D and 1,500 of P-51K were produced. Mustang stayed operational after the War and served in pursuit and attack role even during the Korean War. The last P-51 retired from USAF service in 1978, while in foreign services was operational until 1984 (Dominican Republic). Some 55 nations used the Mustang.

Ace maker and infinite warrior

The first Mustang aerial victory was achieved on August 19, 1942, when Flight Officer Hills shot down an Fw 190. It was the beginning of the incredible tally of 4950 enemy aircraft shot down by Mustang pilots during World War II. Of them, 251 achieved the „ace“ status. The most successful pilot of P-51 was George Preddy Jr., recording 24 of his 27 aerial victories flying Mustang, followed by John C. Meyer and John J. Woll with 21 kills. Famous Charles Yeager, the first man to break the sonic barrier (1947), was the first pilot of P-51D to become Ace in just one day, after recording five kills during October 12, 1944.

ATTENTION



UPOZORNĚNÍ



ACHTUNG



ATTENTION



注意



Carefully read instruction sheet before assembling. When you use glue or paint, do not use near open flame and use in well ventilated room. Keep out of reach of small children. Children must not be allowed to suck any part, or pull vinyl bag over the head.



Před započítím stavby si pečlivě prostudujte stavební návod. Při používání barev a lepidel pracujte v dobře větrané místnosti. Lepidla ani barvy nepoužívejte v blízkosti otevřeného ohně. Model není určen malým dětem, mohlo by dojít k požití drobných dílů.

INSTRUCTION SIGNS * INSTR. SYMBOLS * INSTRUKTION SINNBILDEN * SYMBOLES * 記号の説明

OPTIONAL
VOLBABEND
OHNOUTSAND
BROUSITOPEN HOLE
VYVRTAT OTVORSYMETRICAL ASSEMBLY
SYMETRICKÁ MONTÁŽREMOVE
ODRÍZNOUTREVERSE SIDE
OTOČITAPPLY EDUARD MASK
AND PAINT
POUŽIT EDUARD MASK
NABARVIT**PLEASE CHECK THE LATEST VERSION OF THE INSTRUCTIONS ON www.eduard.com**

PARTS



DÍLY



TEILE



PIÈCES



部品

F>

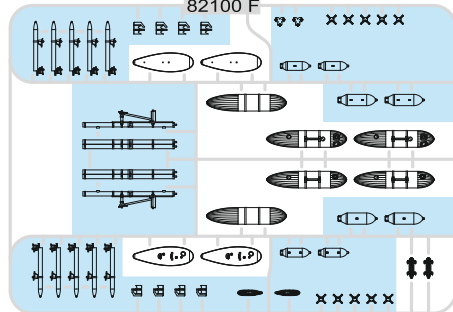

PLASTIC PARTS

K>

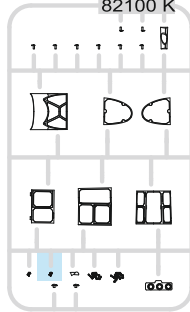

L>

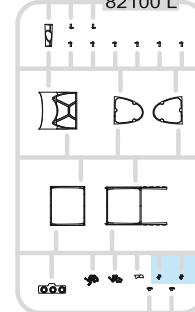

N>

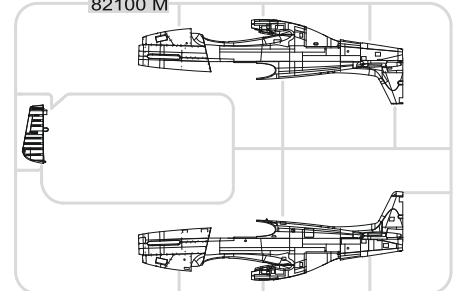

O>

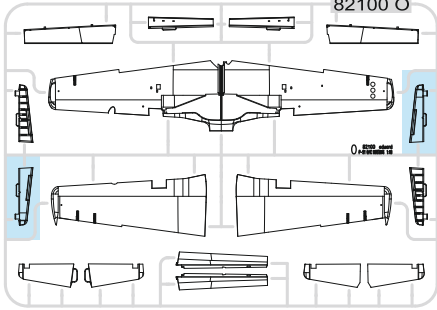

P>

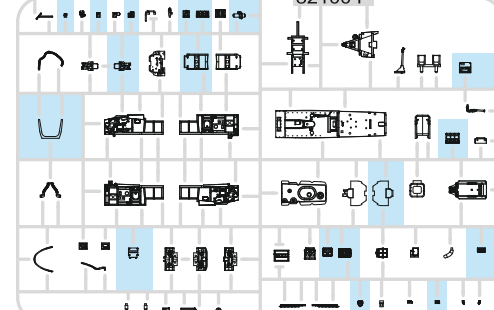

R>

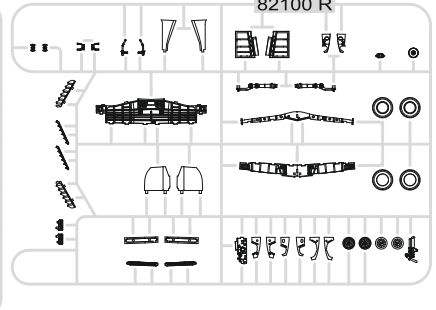

S>

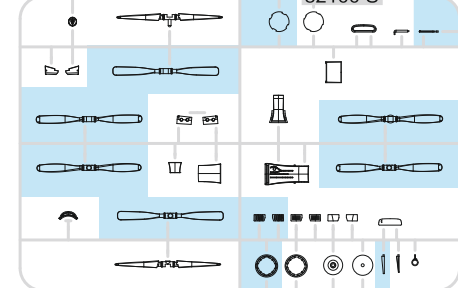

PE - PHOTO ETCHED DETAIL PARTS

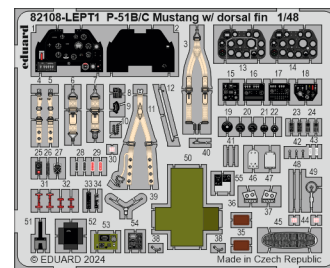
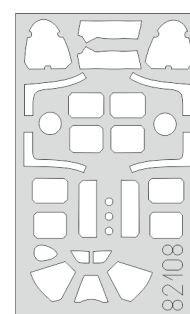
eduard
MASK

-Parts not for use. -Teile werden nicht verwendet. -Pièces à ne pas utiliser. -Tyto díly nepoužívejte při stavbě. - 使用しない部品

COLOURS



BARVY



FARBEN



PEINTURE



色

GSI Creos (GUNZE)		
AQUEOUS	Mr.COLOR	
H1	C1	WHITE
H4	C4	YELLOW
H8	C8	SILVER
H11	C62	FLAT WHITE
H12	C33	FLAT BLACK
H27	C44	TAN
H47	C41	RED BROWN
H52	C12	OLIVE DRAB
H53	C13	NEUTRAL GRAY
H58	C351	INTERIOR GREEN
H74	C368	SKY
H77	C137	TIRE BLACK
H90	C47	CLEAR RED
H92	C49	CLEAR ORANGE

GSI Creos (GUNZE)		
AQUEOUS	Mr.COLOR	
H94	C138	CLEAR GREEN
H327	C327	RED
H329	C329	YELLOW
H330	C361	DARK GREEN
H335	C363	MEDIUM SEAGRAY
	C352	CHROMATE YELLOW
	C362	OCEAN GRAY
Mr.METAL COLOR		
MC214		DARK IRON
Mr.COLOR SUPER METALLIC		
SM201		SUPER FINE SILVER
SM203		SUPER IRON

1 = 90% + 10%
 H58 C351 INTERIOR GREEN H12 C33 FLAT BLACK

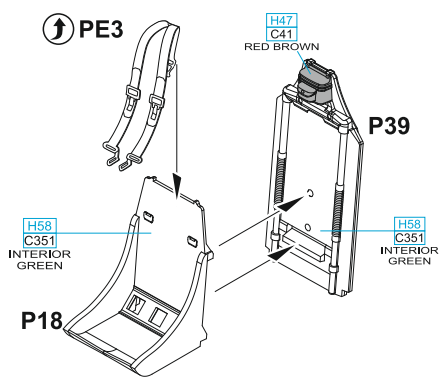

P18, P39 - MARKING A

PE11- MARKING C ONLY

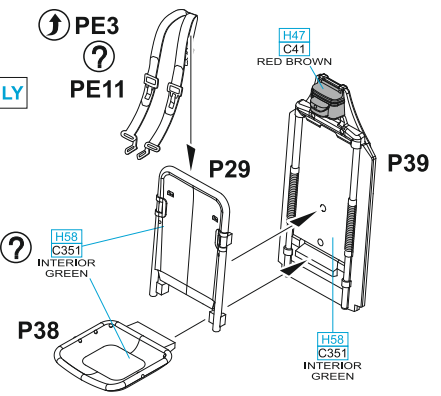

P29, P38, P39 - MARKINGS B, C, D, E, F

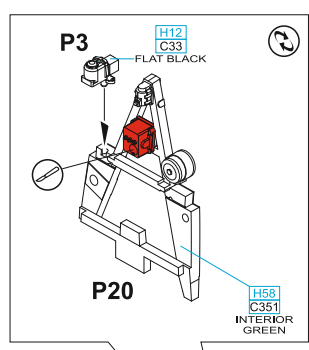

1 ? H52 C12 OLIVE DRAB ? H58 C351 INTERIOR GREEN

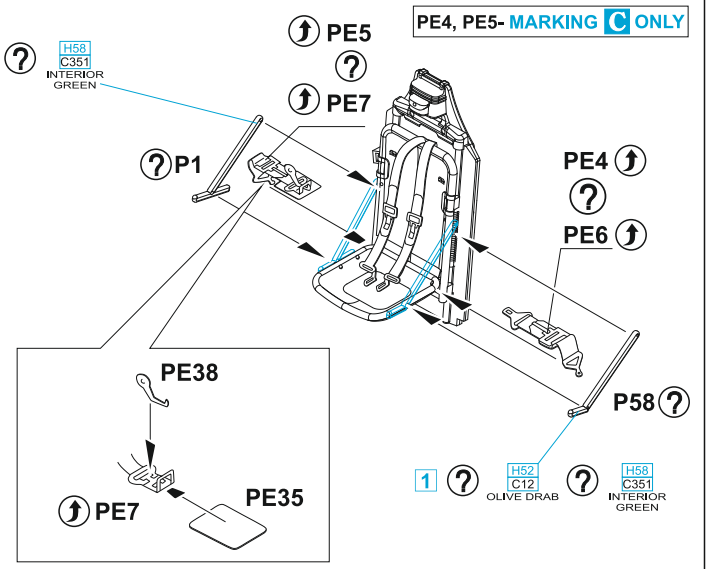

P1, P58 - MARKINGS B, C, D, E, F ONLY

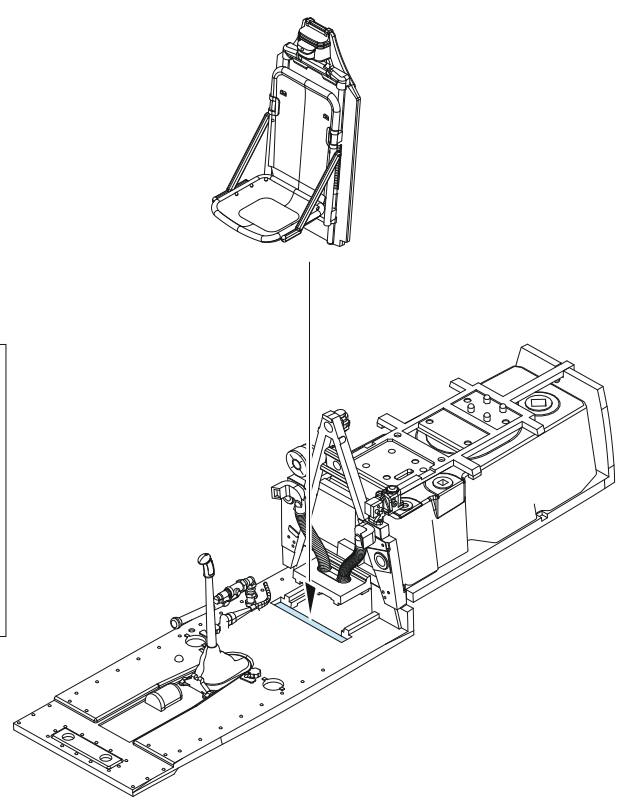
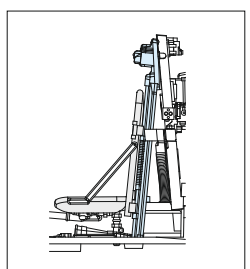
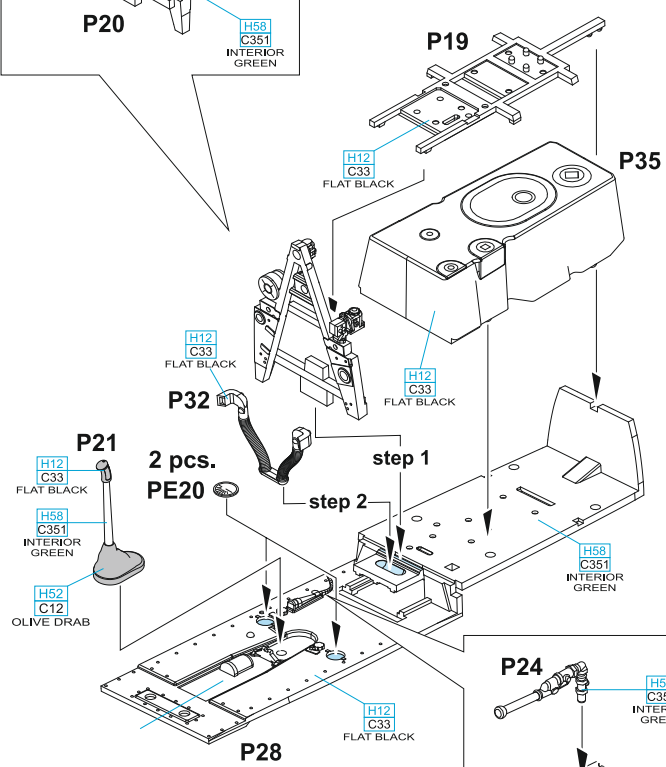

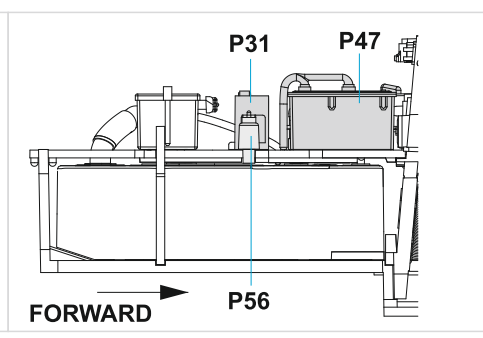
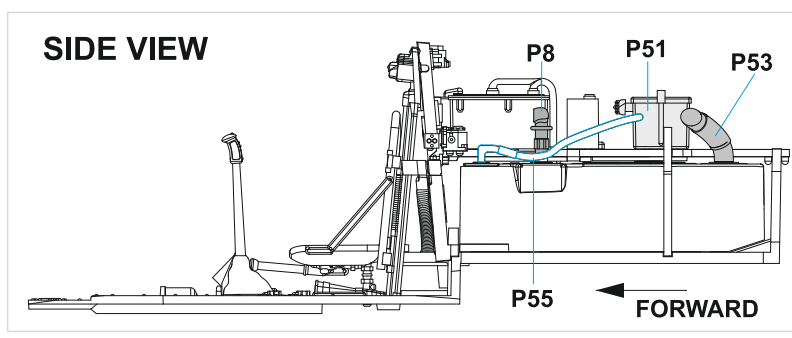
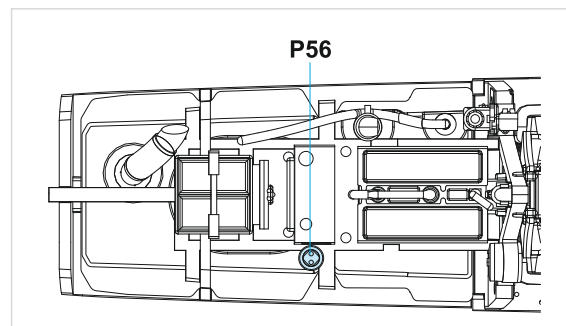
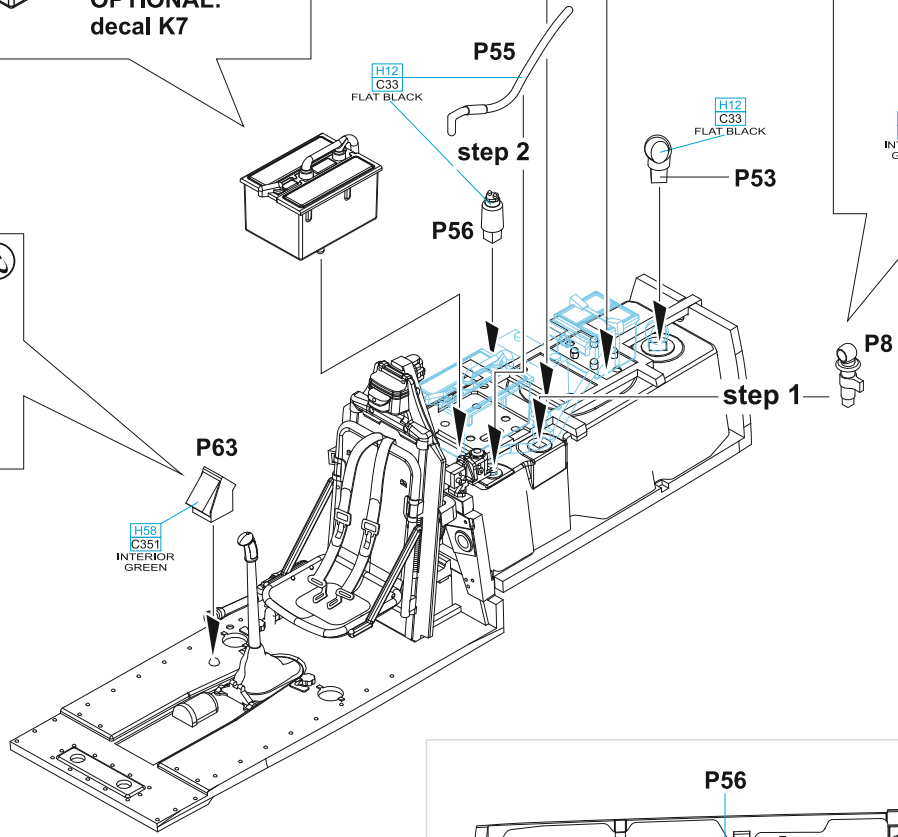
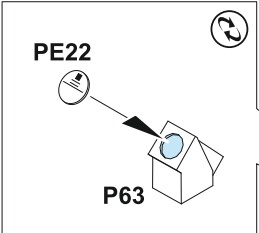
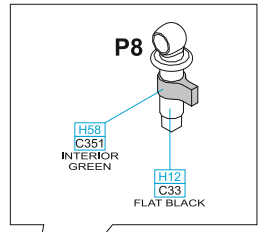
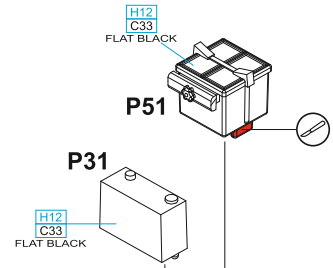
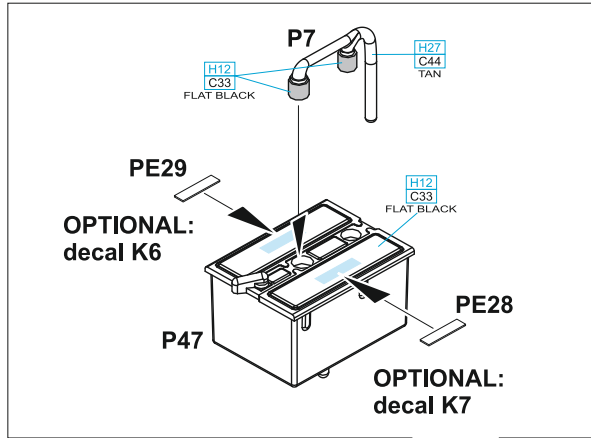

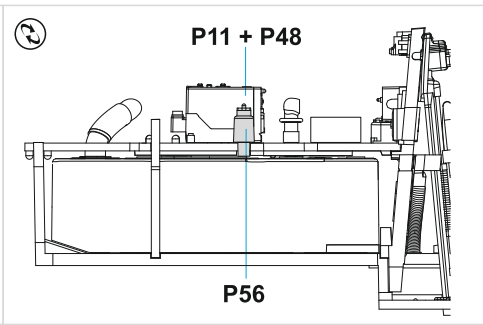
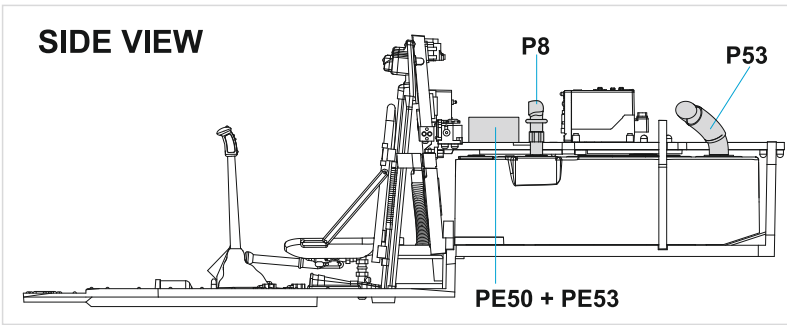
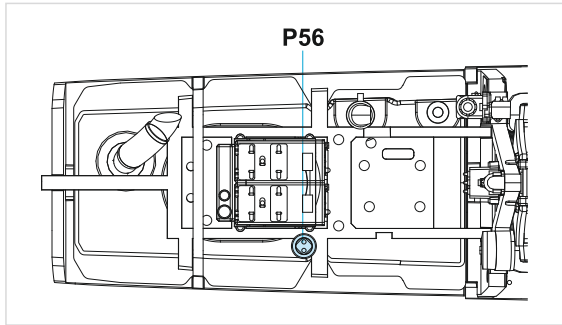
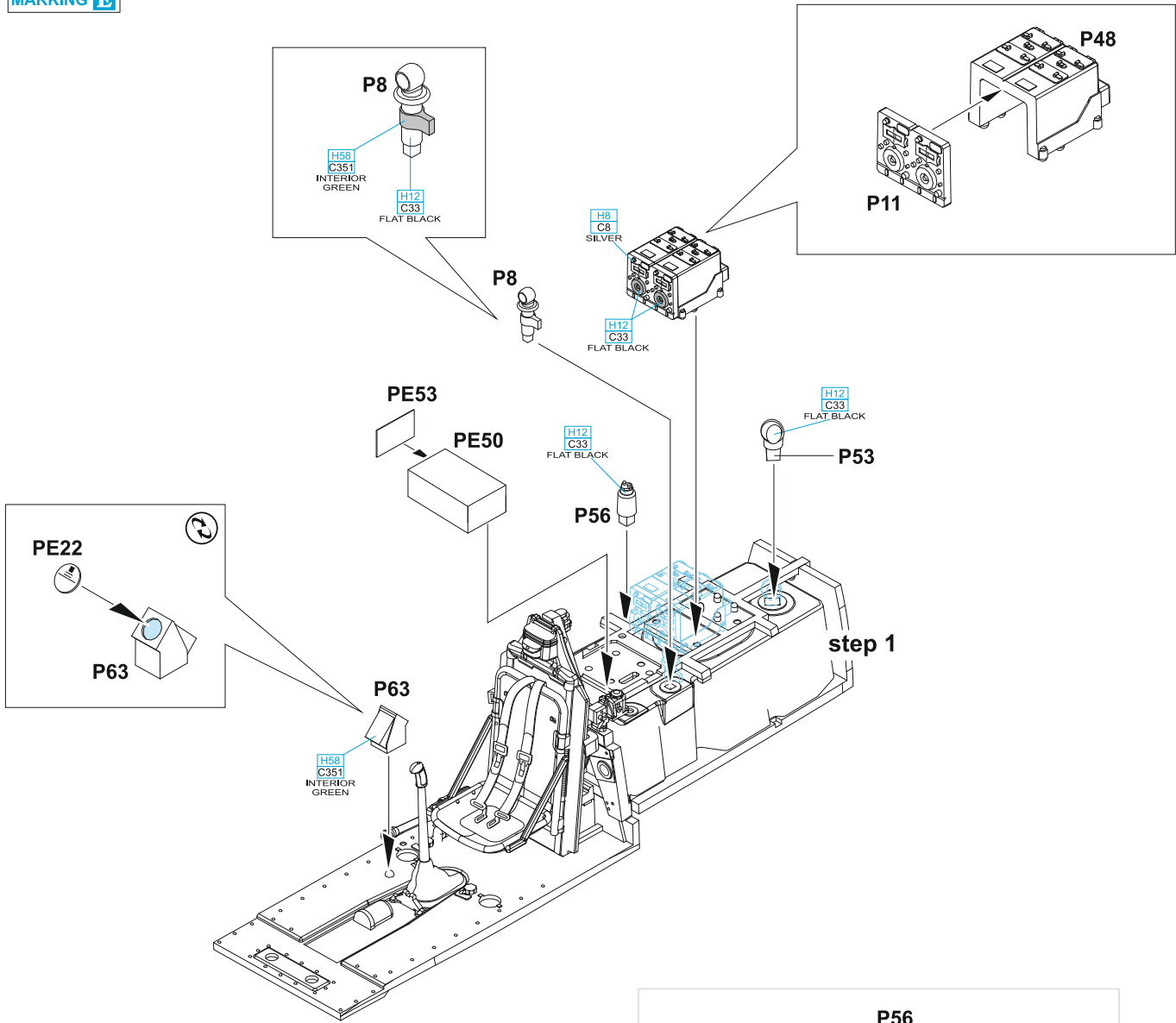

B MARKINGS **A, B, C**

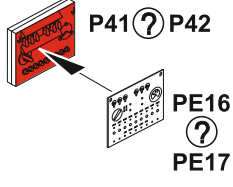
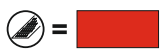
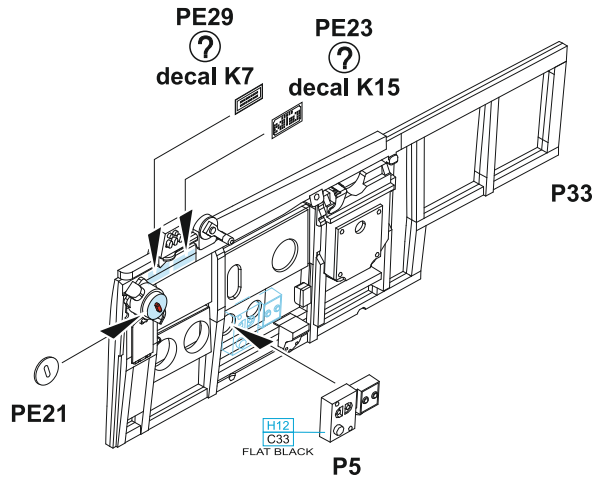
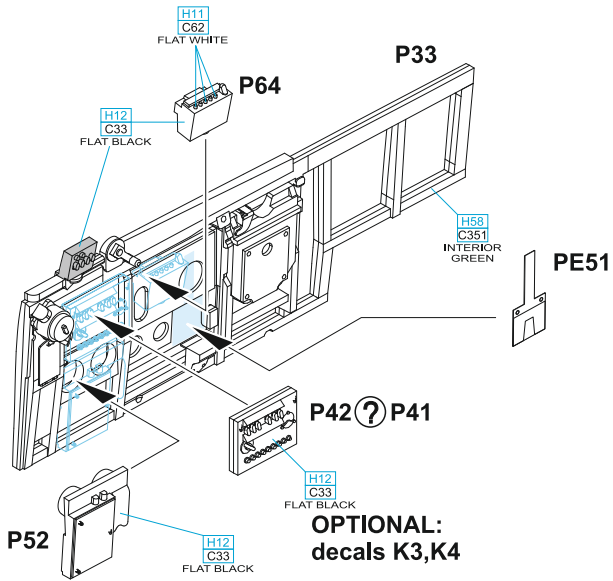

P41, K3 ? PE16 - MARKING C ONLY



MARKINGS **D, E, F**

P64 - MARKINGS **D, F** ONLY

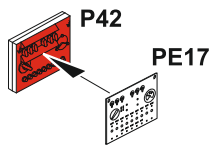
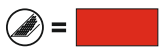
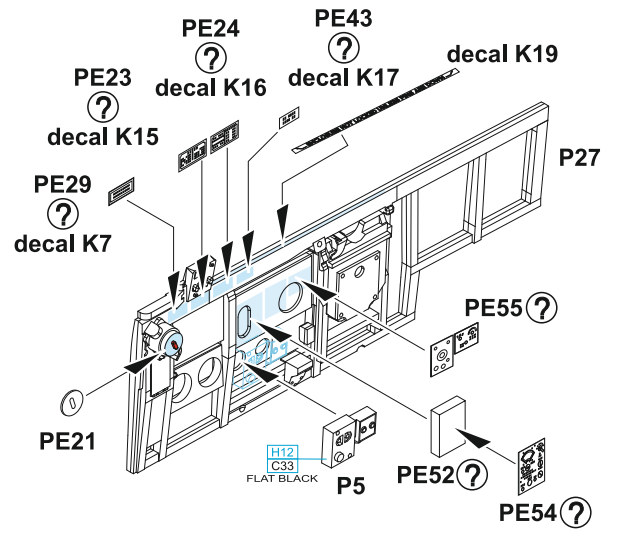
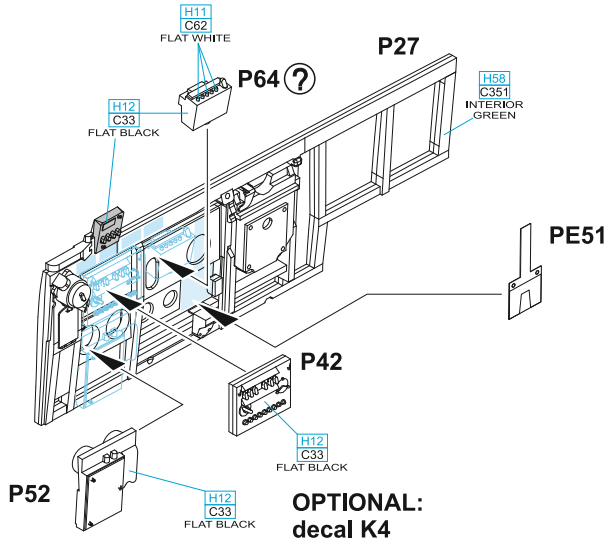

PE52, PE54, PE55 - MARKING E ONLY

C

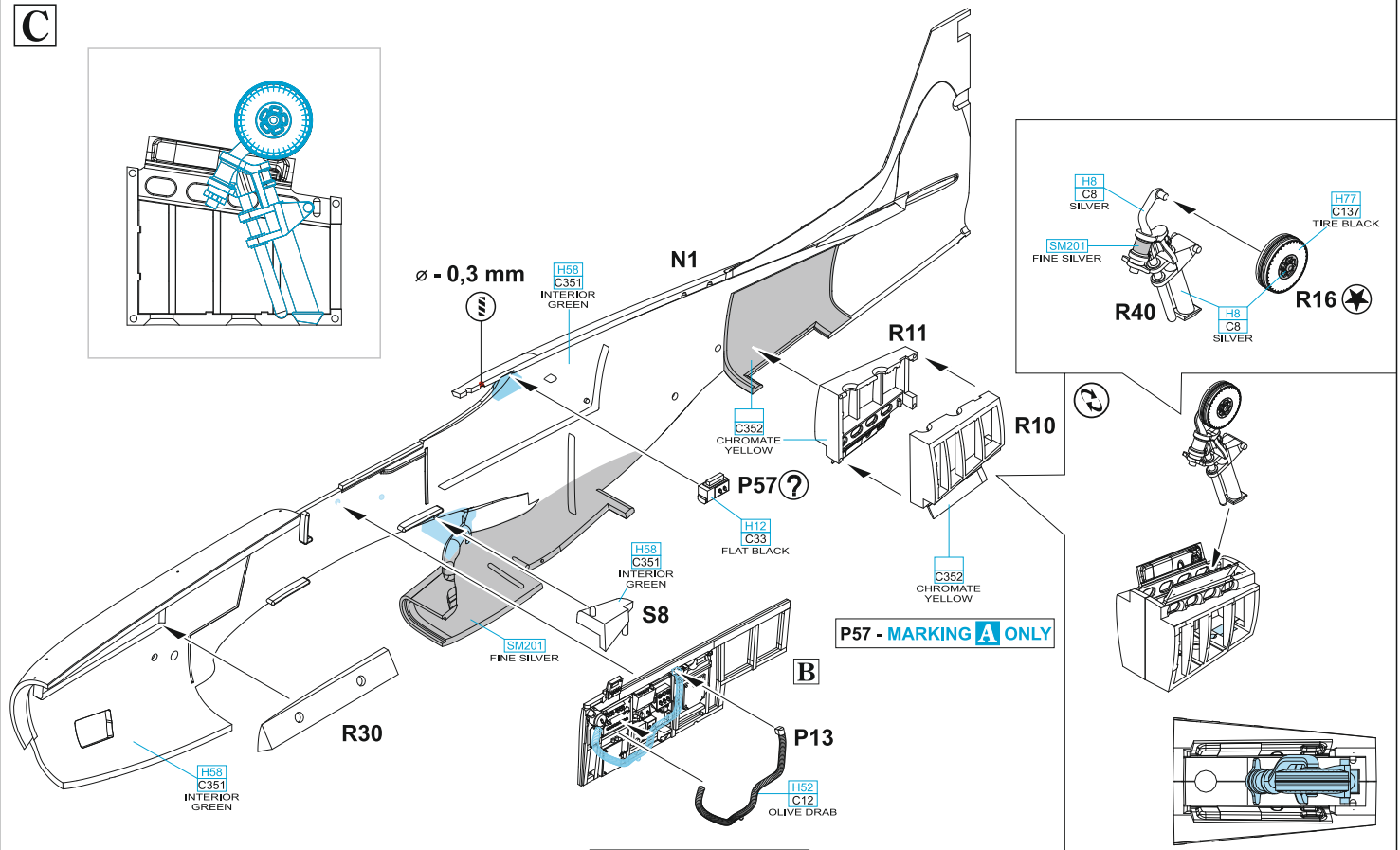

D

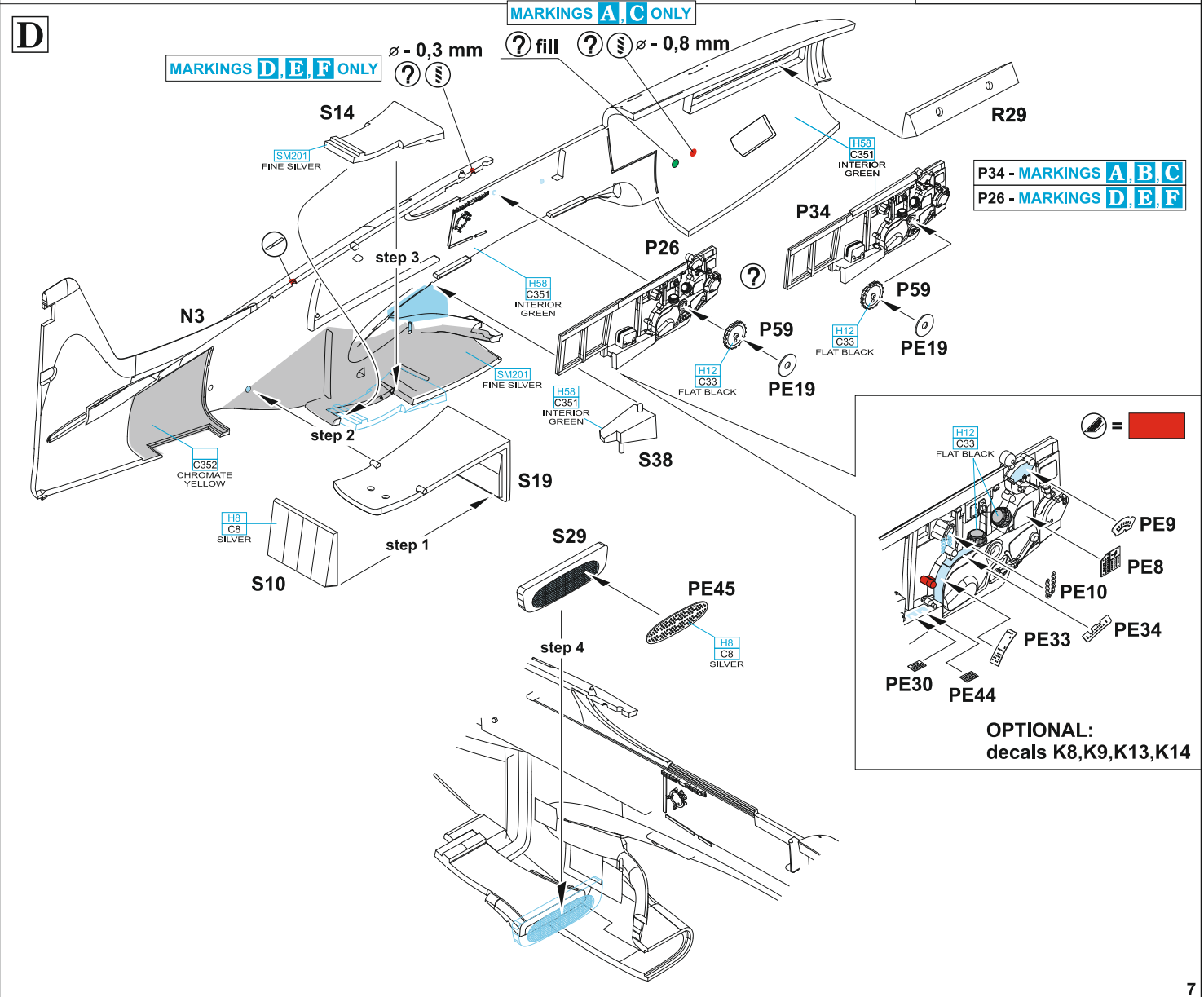

L5, L7 - MARKINGS **A, B, C**
 K6, K8 - MARKINGS **D, E, F**

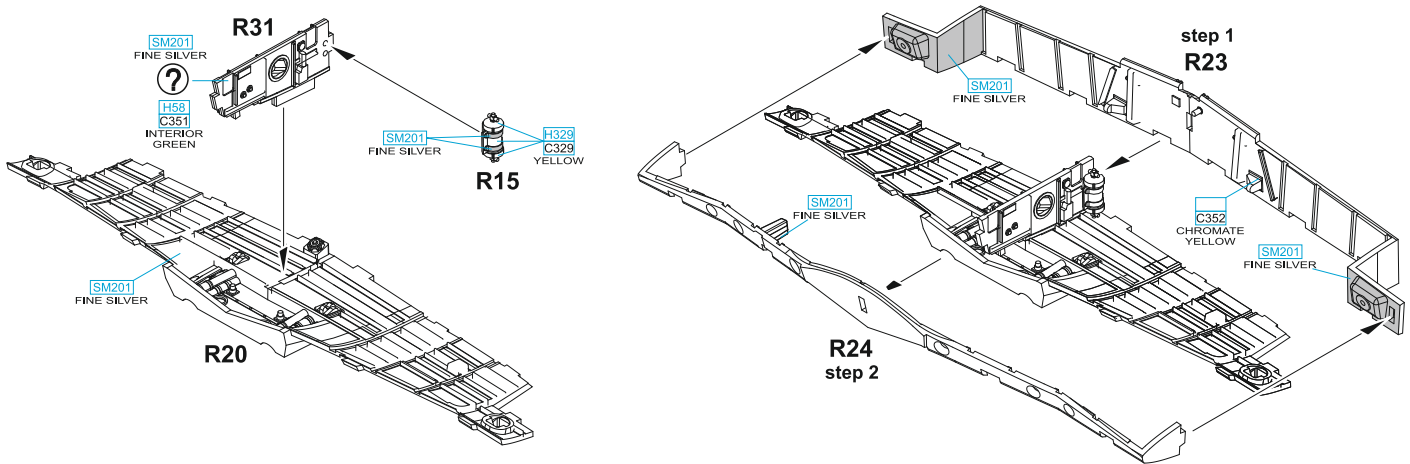
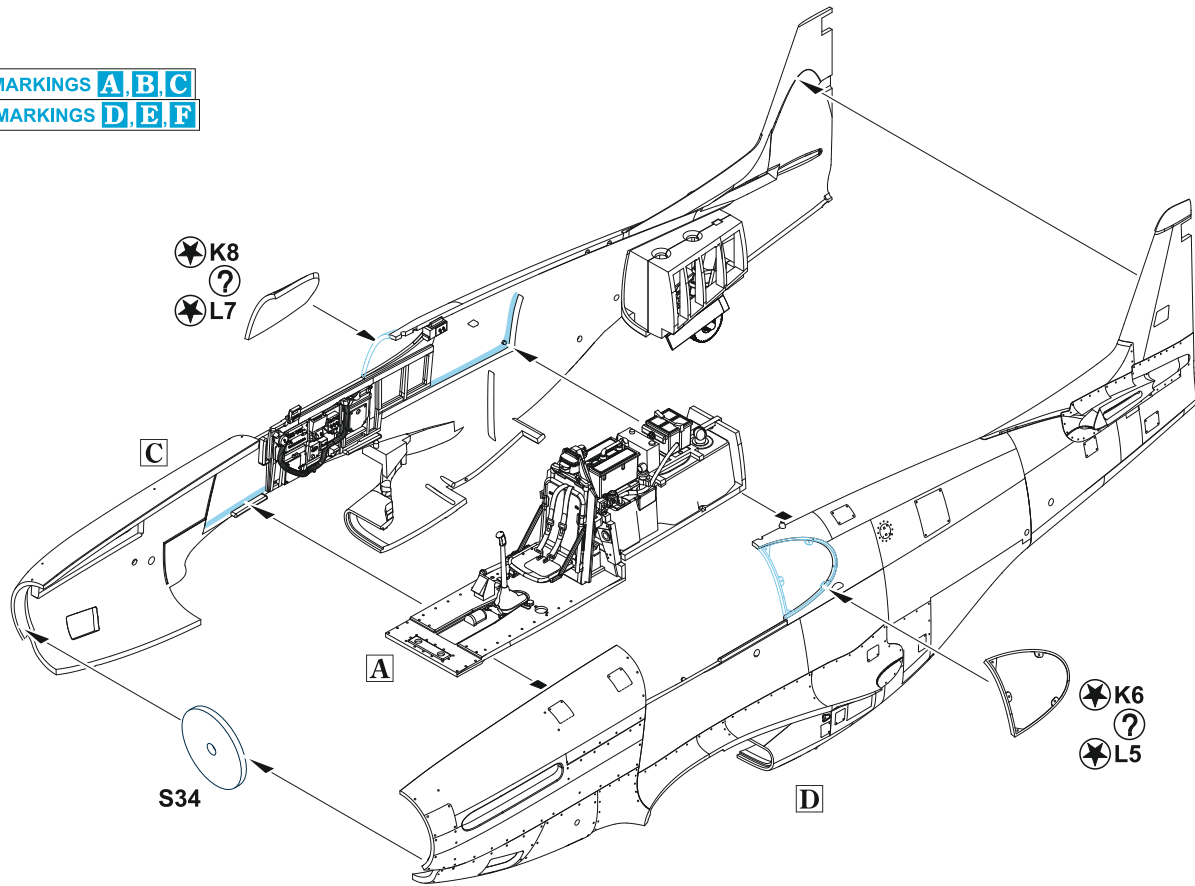

E

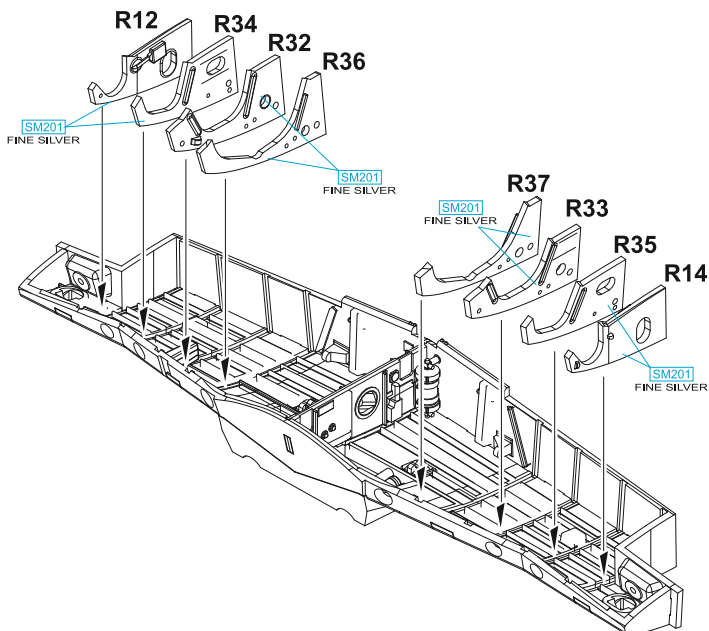

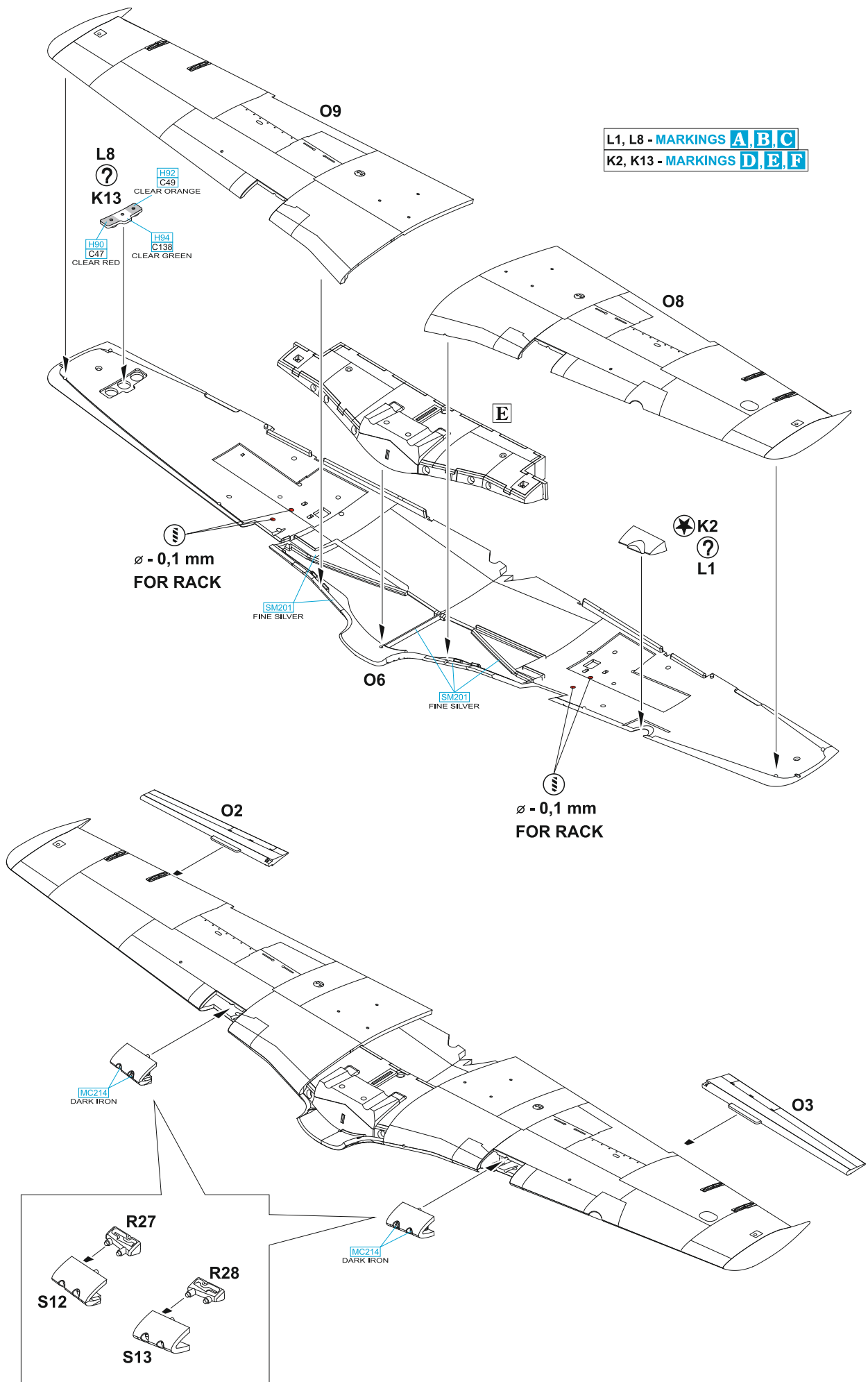

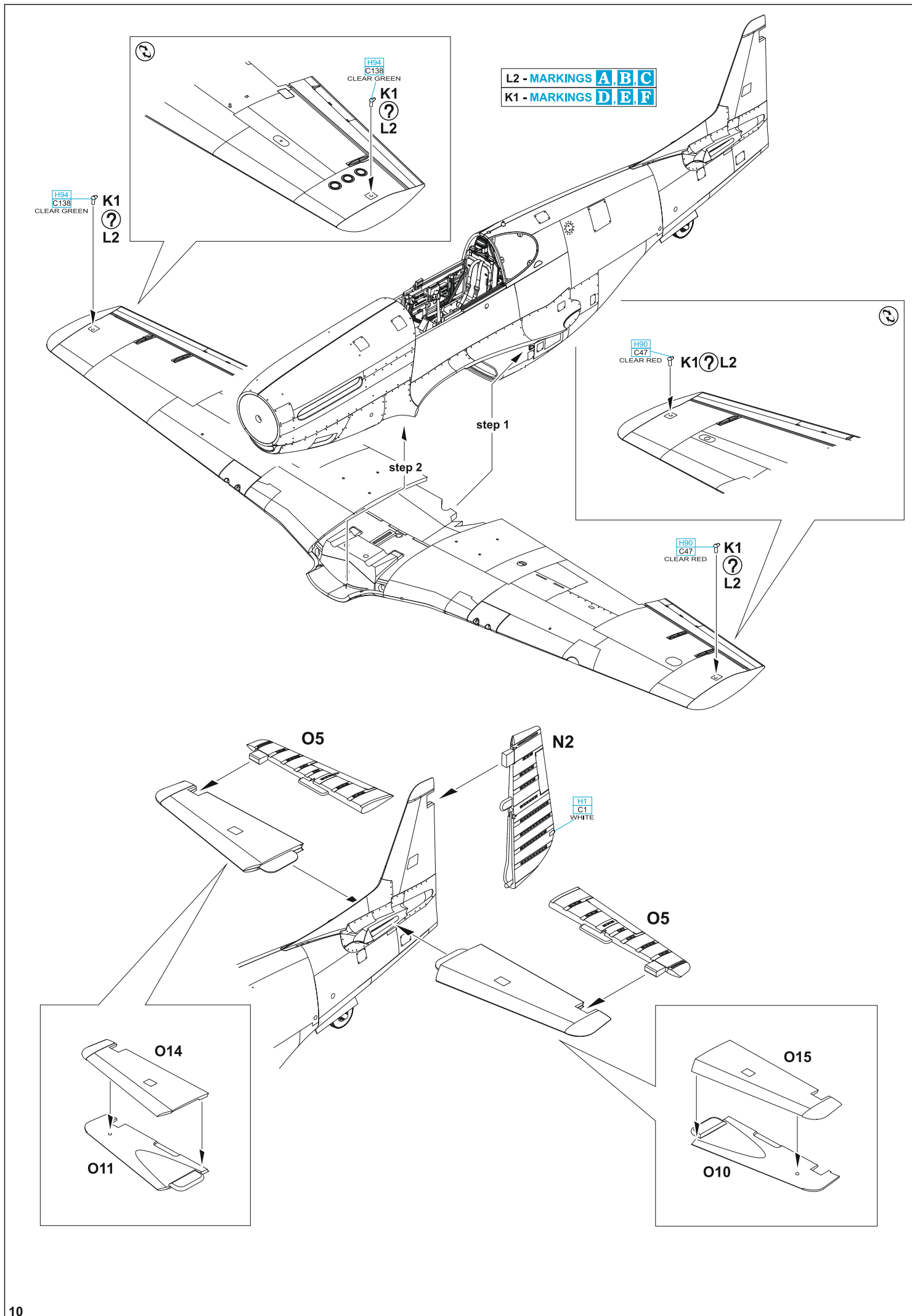

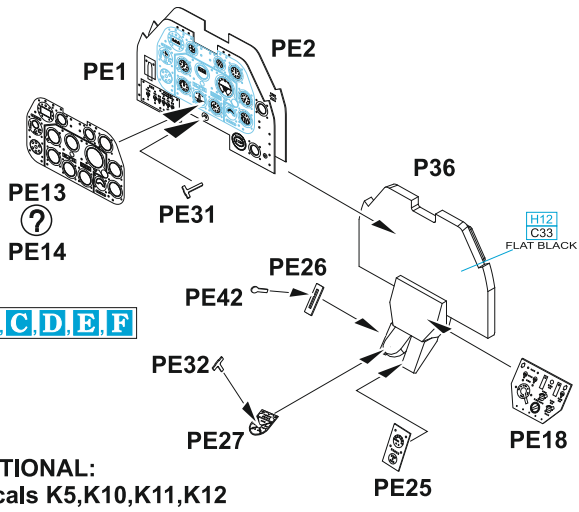

PE14 - MARKING **A**
PE13 - MARKINGS **B, C, D, E, F**

OPTIONAL:
decals K5, K10, K11, K12

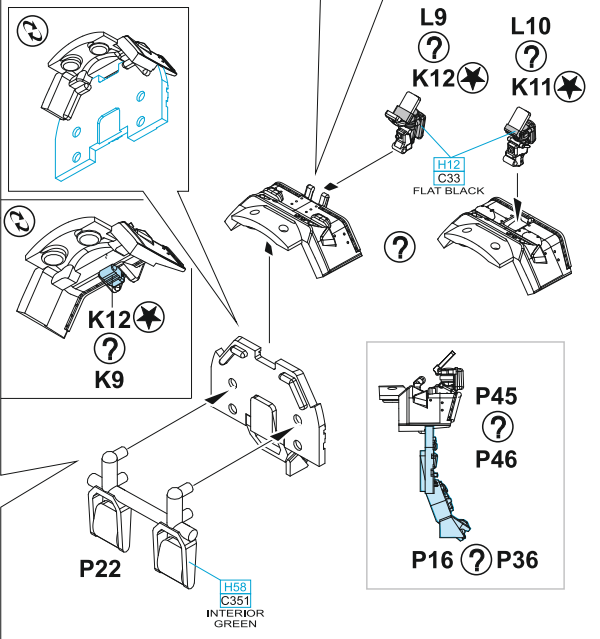
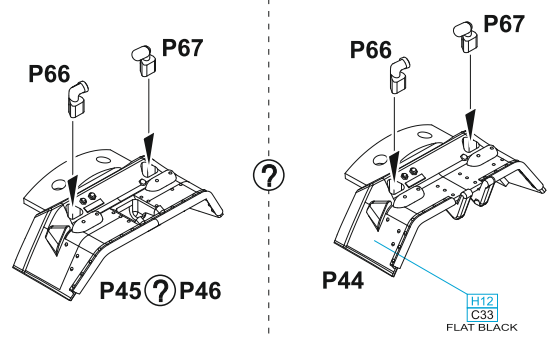

L10, K11 - MARKINGS **A, C, D, E, F**
L9, K12 - MARKING **B**

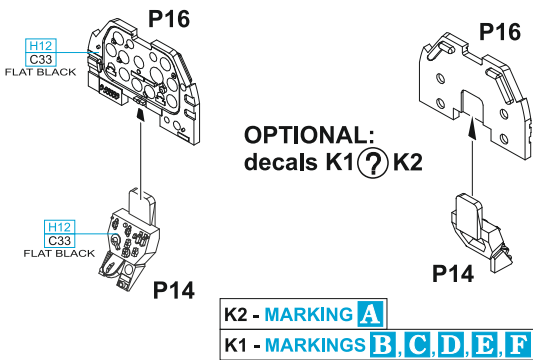

K2 - MARKING **A**
K1 - MARKINGS **B, C, D, E, F**

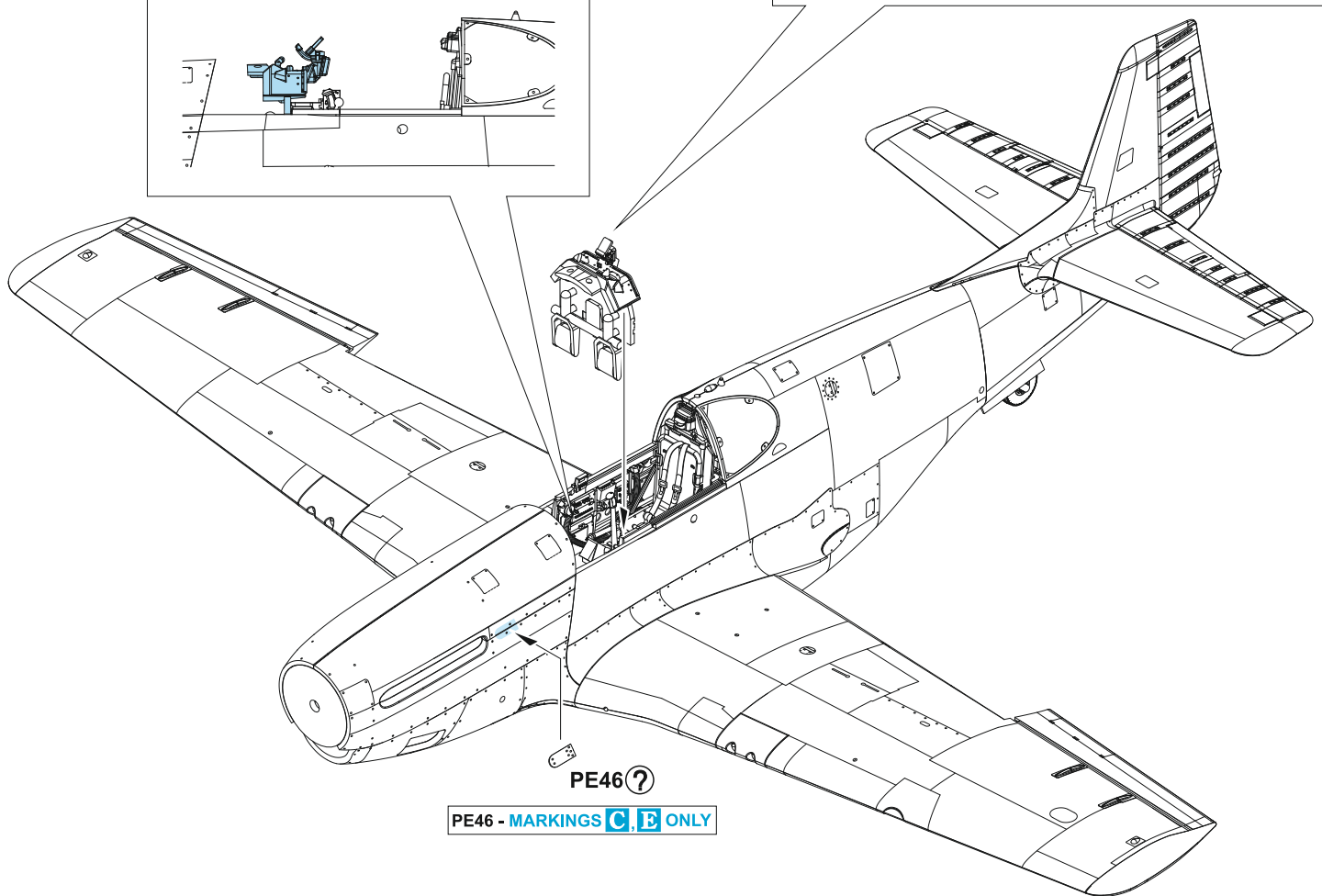
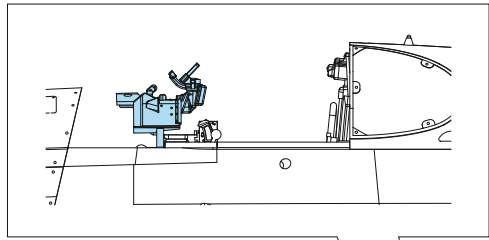

PE46 - MARKINGS **C, E ONLY**

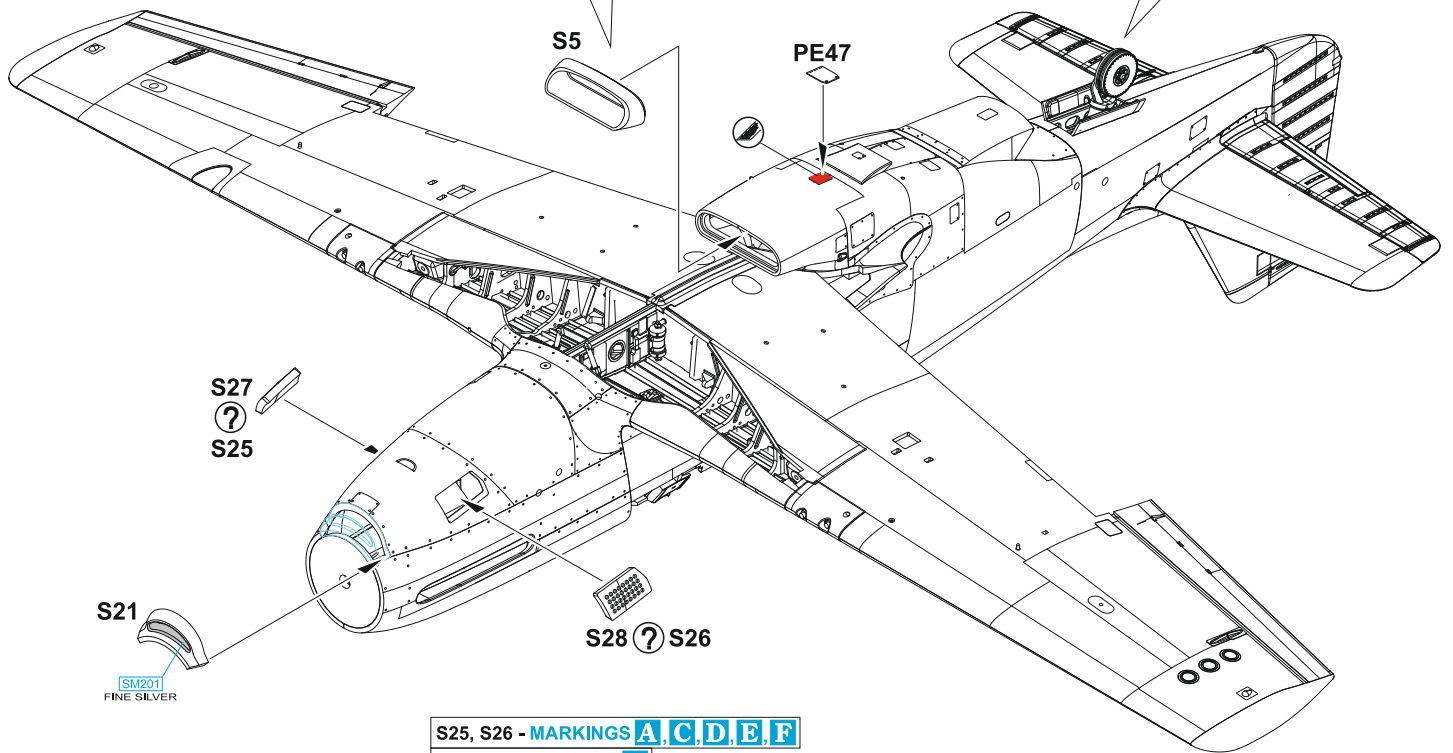
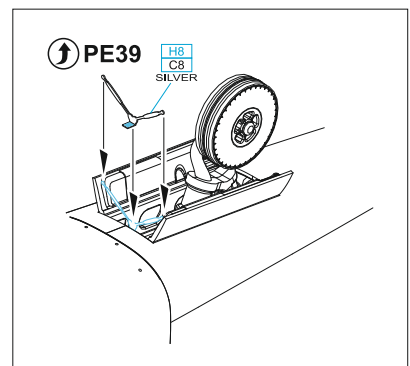
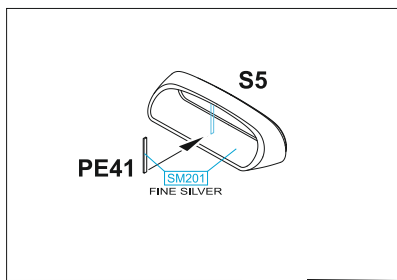
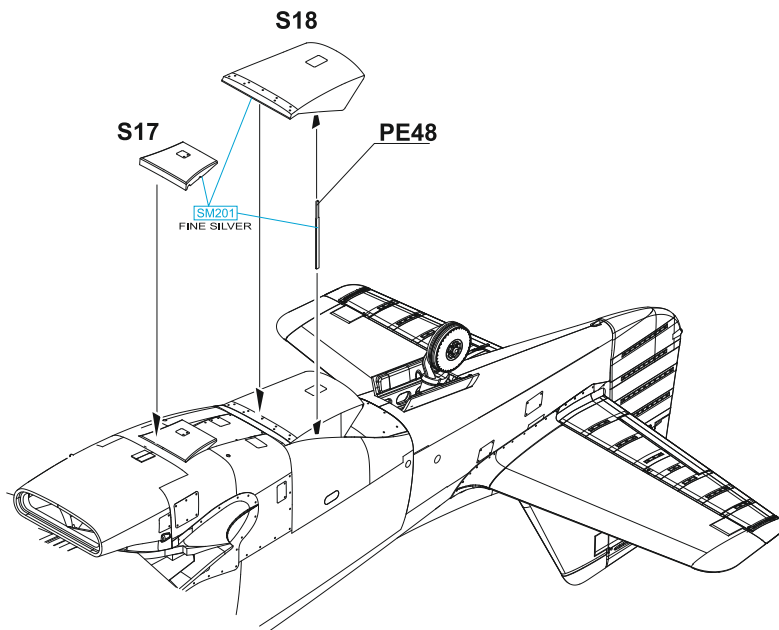

S25, S26 - MARKINGS **A, C, D, E, F**
 S27, S28 - MARKING **B**

step 1 -
R25, R26
step 2 -
R38, R39

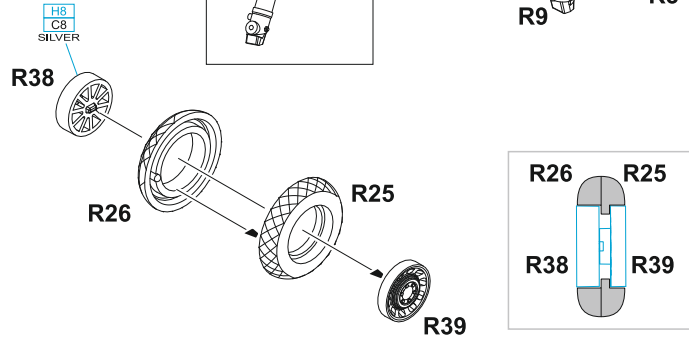

step 1 -
R25, R26
step 2 -
R38, R39

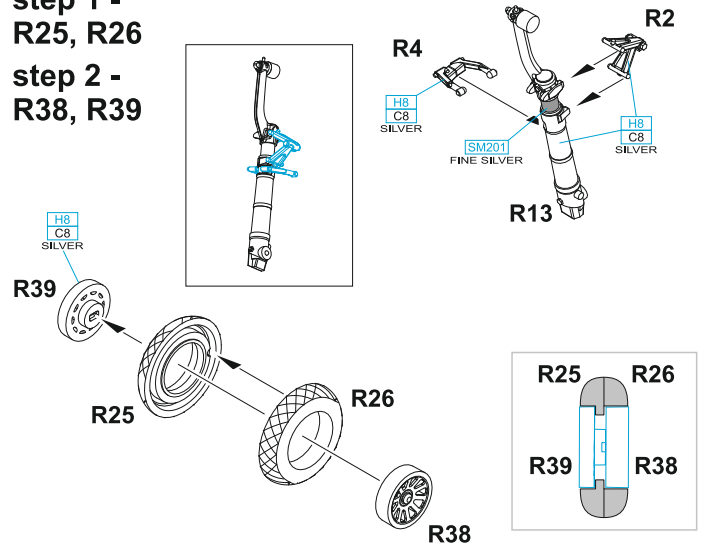

F

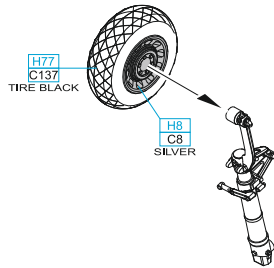

G

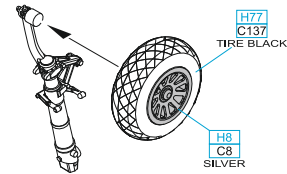

H

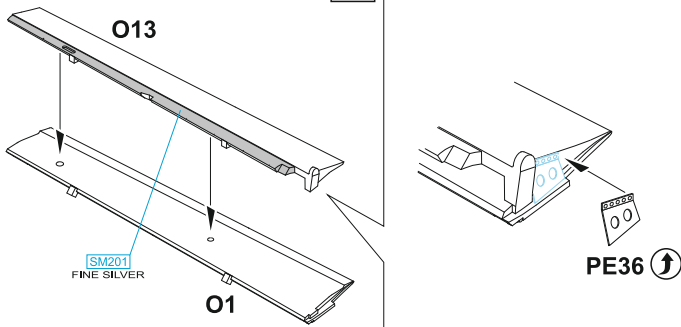

I

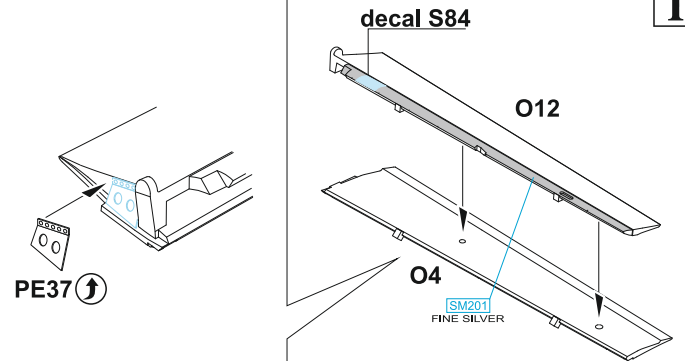

eduard
MASK
82108

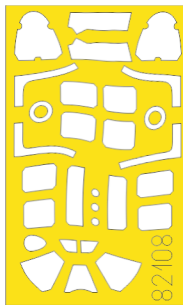

K13 L8



R16



K2 L1

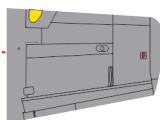

K6 K8

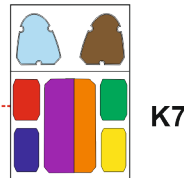

L7

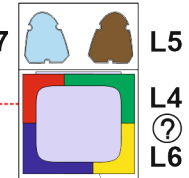

LIQUID MASK

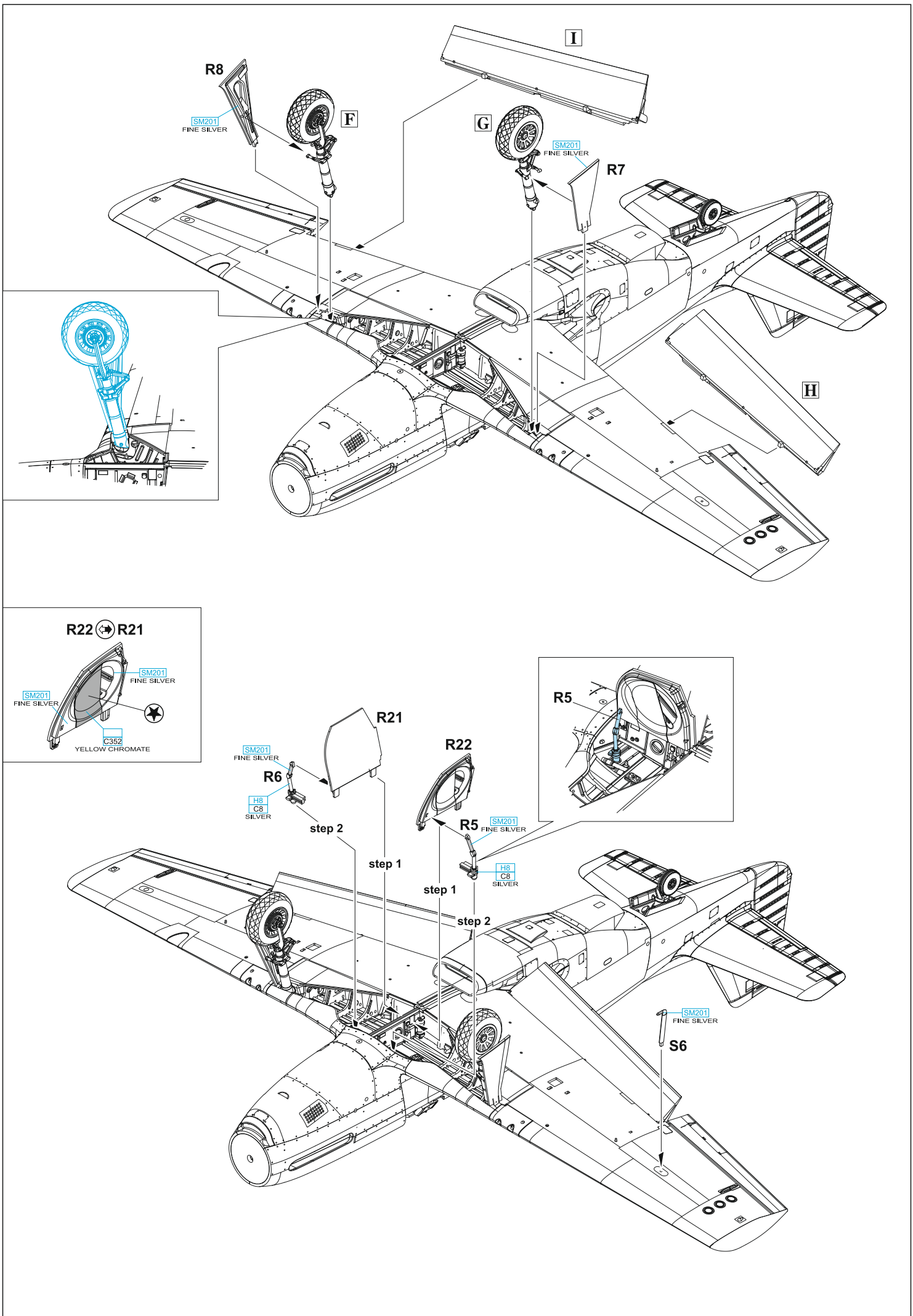

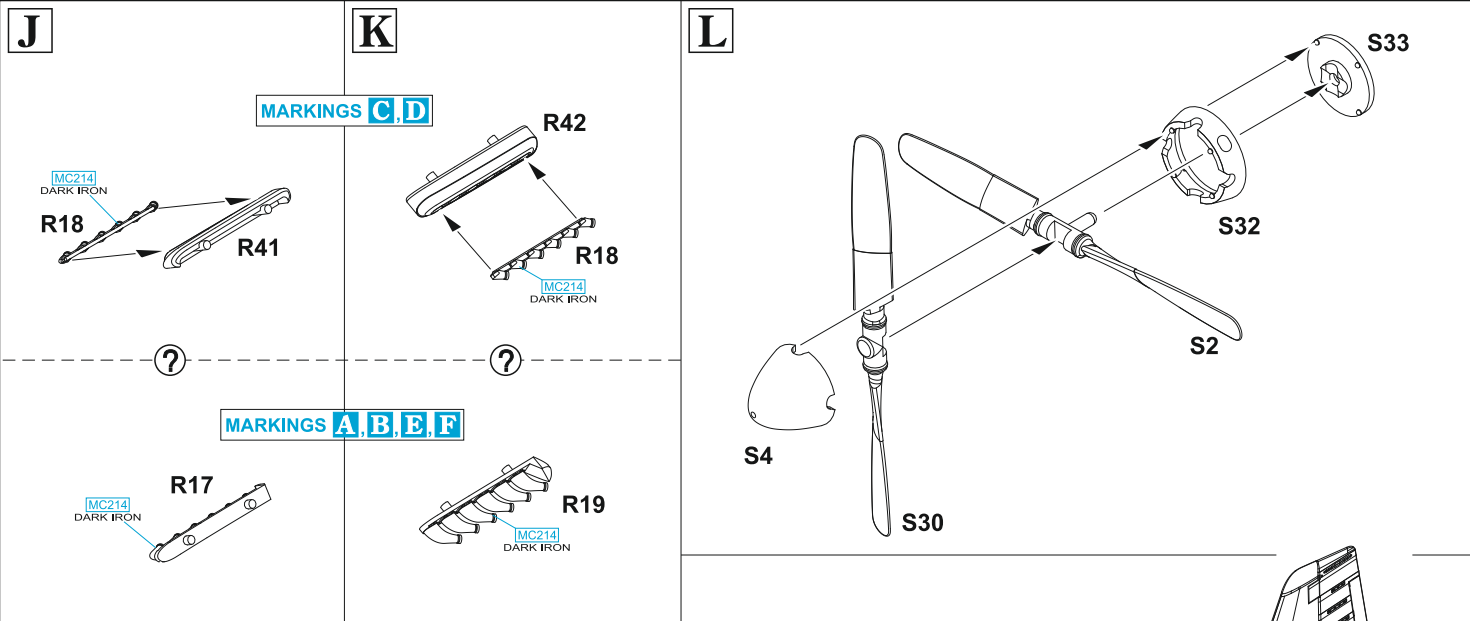

MARKINGS **A, B, C**

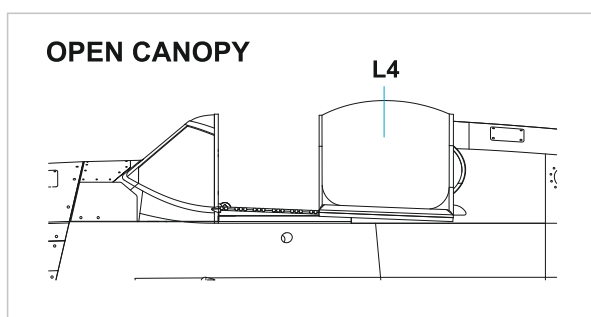

P60, P61, P40 - OPEN CANOPY ONLY

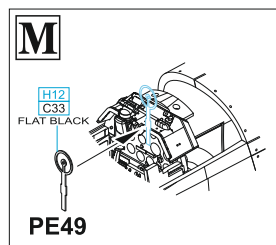
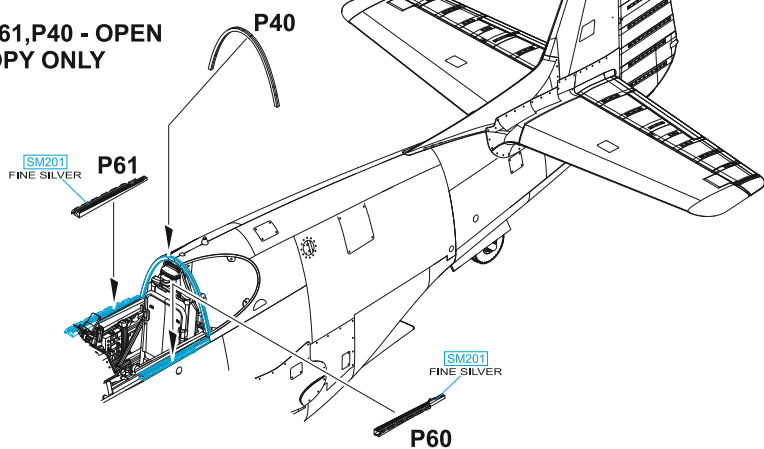

CLOSED CANOPY

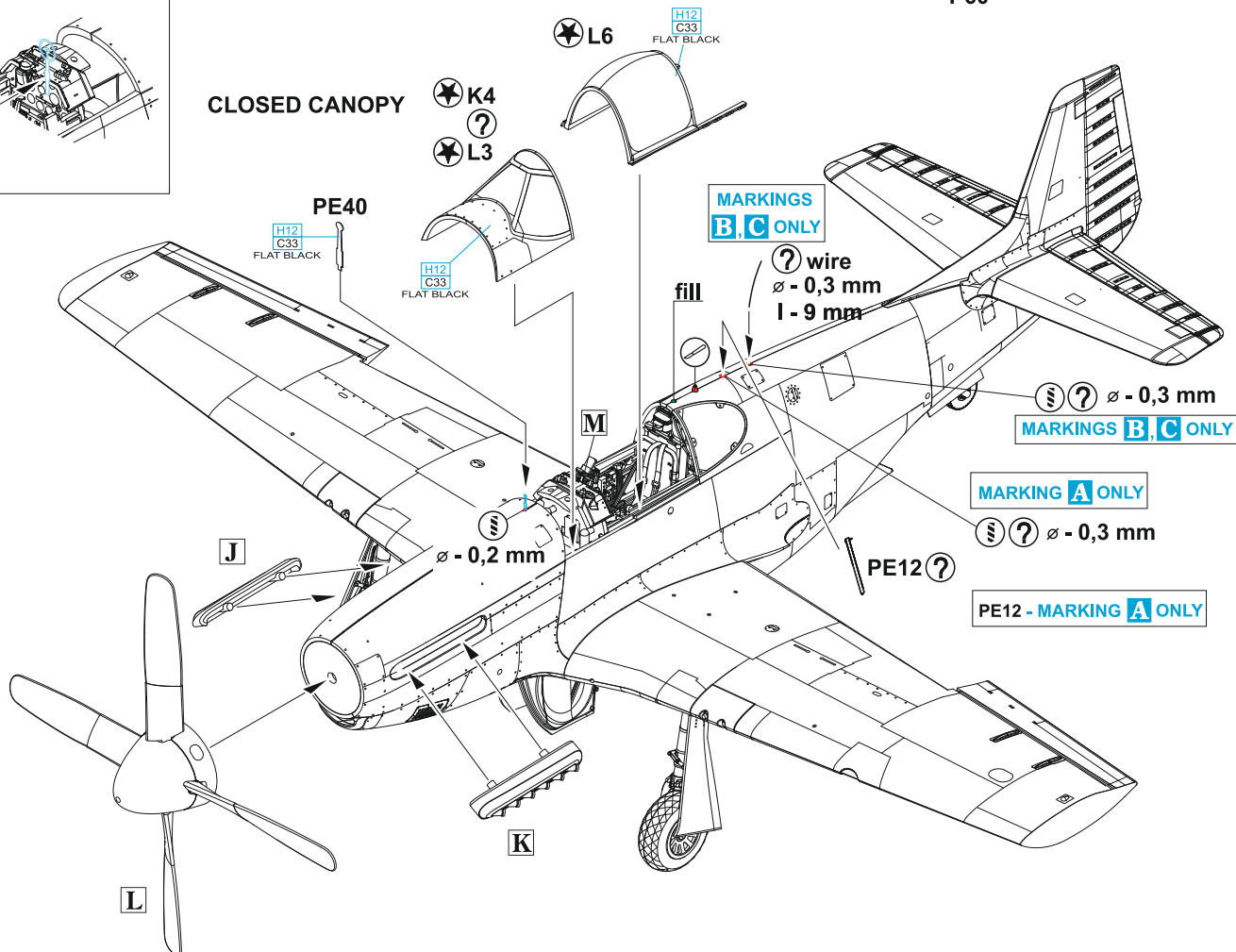

MARKINGS **D, E, F**

S1, S37 - MARKING **E** ONLY

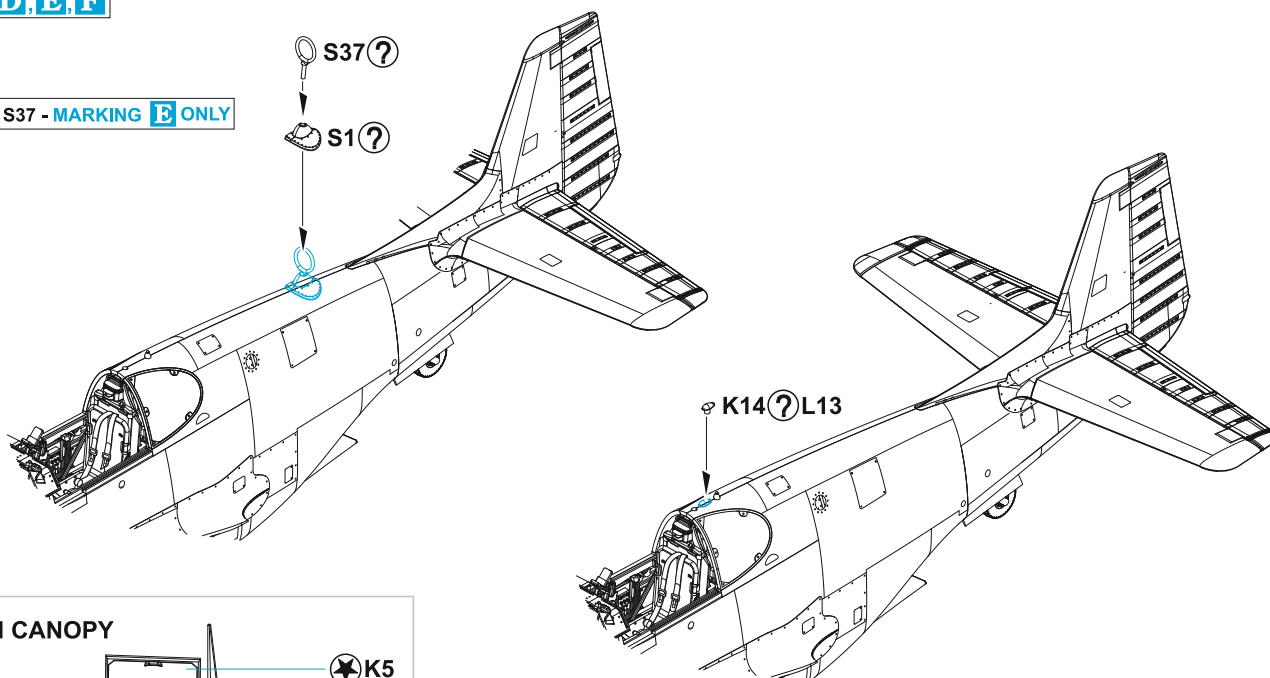

OPEN CANOPY

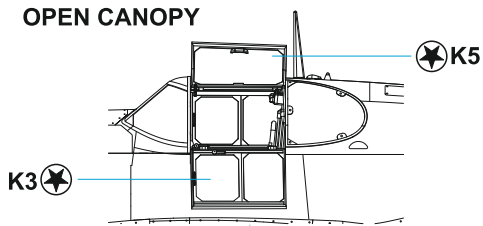

NO STEP decal K18

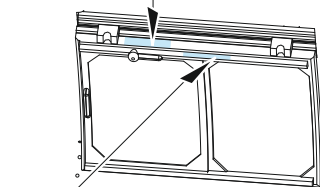

NO STEP decal K18

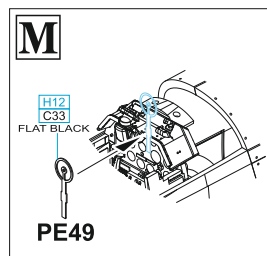

CLOSED CANOPY

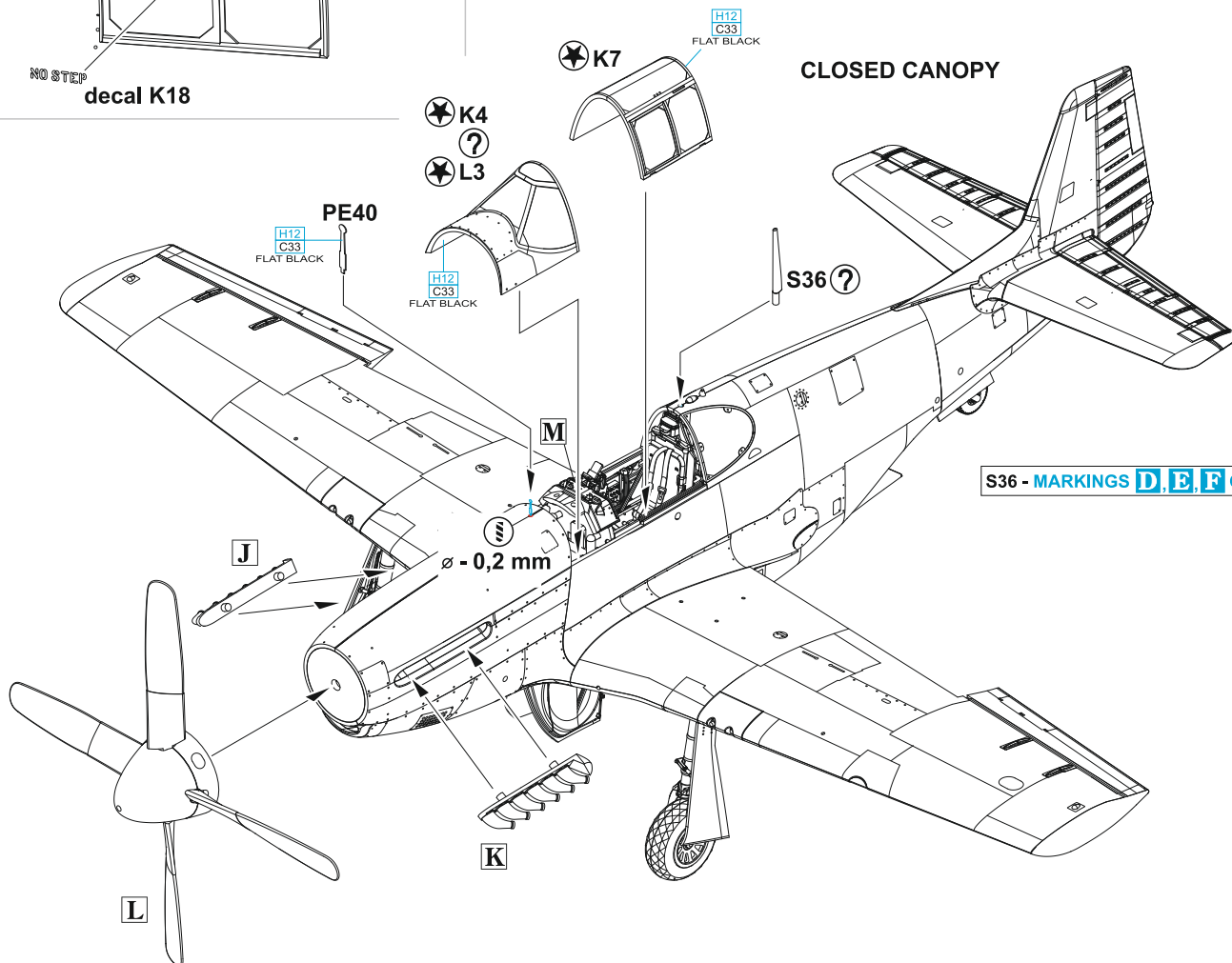

S36 - MARKINGS **D, E, F** ONLY

N

2 pcs.

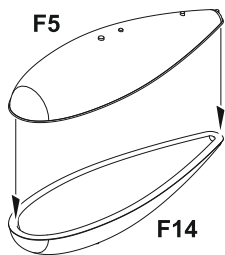

O

2 pcs.

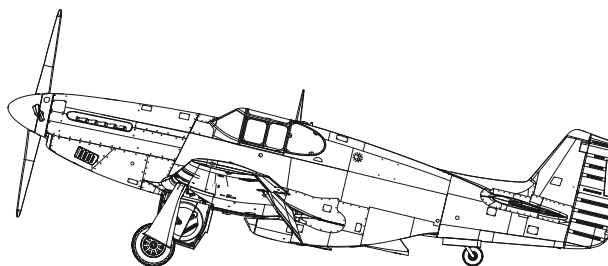
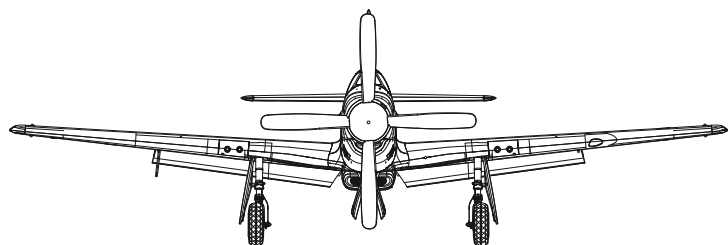
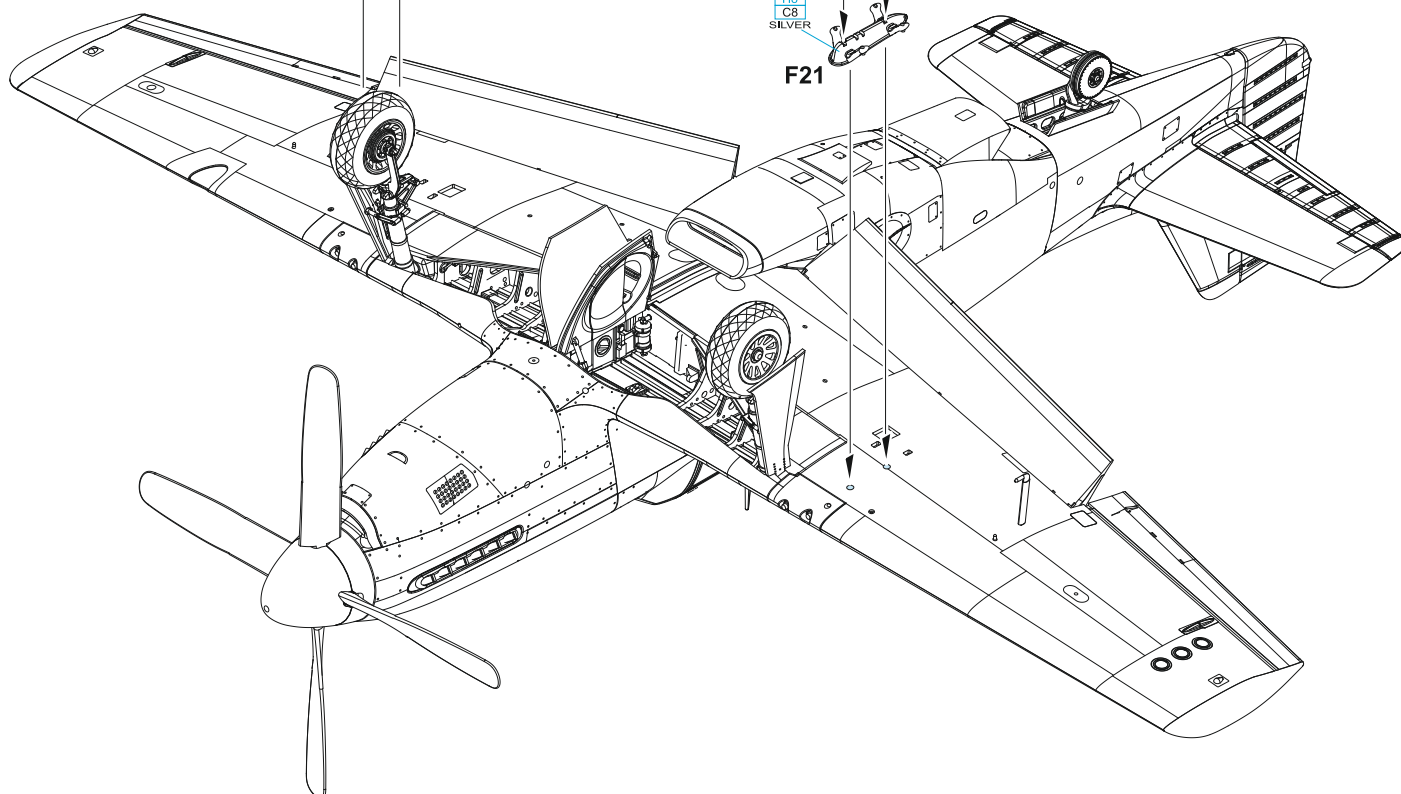
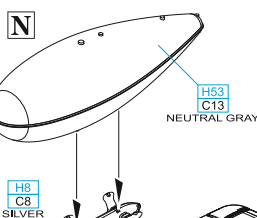
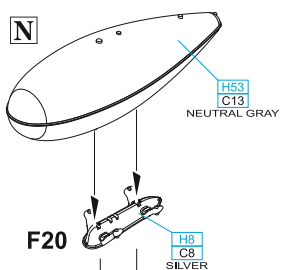
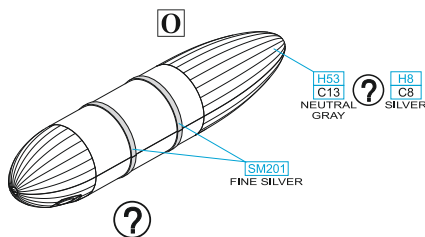
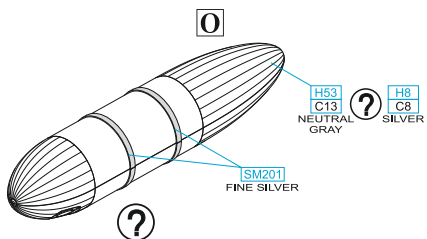
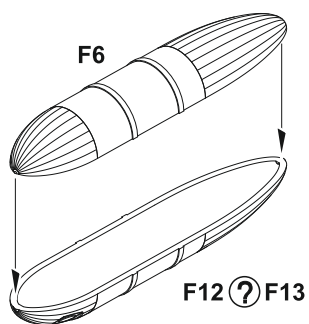

B P-51C-10-NT, s/n 43-25054, Lt. Robert M. Scott, 79th FS, 20th FG, 8th AF, Kings Cliffe, Northamptonshire, United Kingdom, November 1944

A Mustang of four forms, that's what you could call the color history of this P-51C s/n 43-25054. At the start, when the aircraft lacked the fin, Lt. W. H. Lewis was flying it. At that time, the aircraft was camouflaged with Olive Drab paint on the upper surfaces and bore the inscription Hells Belle and a small devil painting. After the fin was applied and the Olive Drab camouflage was partially removed especially in the fuselage area, the aircraft received black and white stripes on the nose and the Beaverhead Filly lettering was painted on the port side. The Mustang thus painted was flown by Lt. Keith C. Price, who scored his only kill in it. Lt. Robert M. Scott was the next pilot to take over this aircraft and had the inscription Shoot You're Faded painted on the port side of its engine cowling. The inscription Berties Bet was later added. Throughout its wartime career, this Mustang was cared for by the same mechanic and armorer, Sgt. E. Schrader and Sgt. A. Kublin. Under their care, this Mustang flew over 700 hours during the war and lived to see the end of it. It finally crashed near Munich after the war.

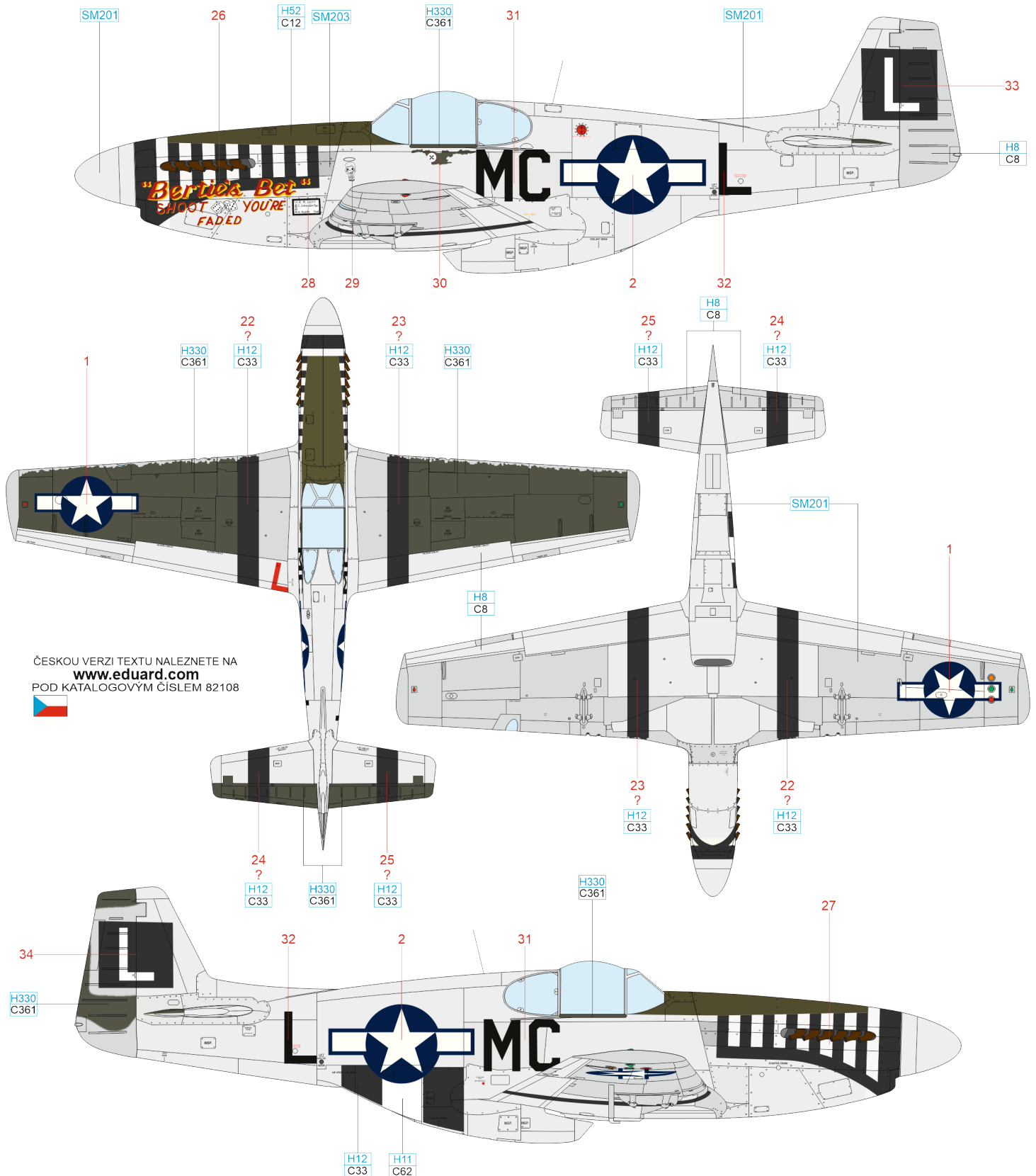

ČESKOU VERZI TEXTU NALEZNETE NA
www.eduard.com
 POD KATALOGOVÝM ČÍSLEM 82108



DARK GREEN	H330 C361	SUPER FINE SILVER 2	SM201
SILVER	H8 C8	OLIVE DRAB	H52 C12
	FLAT WHITE	H11 C62	
	FLAT BLACK	H12 C33	
	SUPER IRON 2		SM203

C Mustang Mk.III, s/n FZ111, F/L Mieczysław Gorzula, No. 309 (Polish) Squadron, RAF Andrews Field, United Kingdom, April - May 1945

F/Lt Mieczysław Gorzula was one of the few British RAF pilots flying Mustang aircraft who managed to shoot down a Me 262 jet fighter in aerial combat at the end of World War II. On April 9, 1945, while escorting Lancaster bombers heading for Hamburg, he led a blue section of three Mustangs as commander of B Flight of No. 309 Squadron. Soon after the bombers left the target the formation was attacked by several Me 262s. Gorzula managed to approach one of them and shoot it down. His Mustang Mk.III serial number FZ111, which he regularly flew, bore a drawing of his beloved Englishwoman Jean on the left side of the nose.

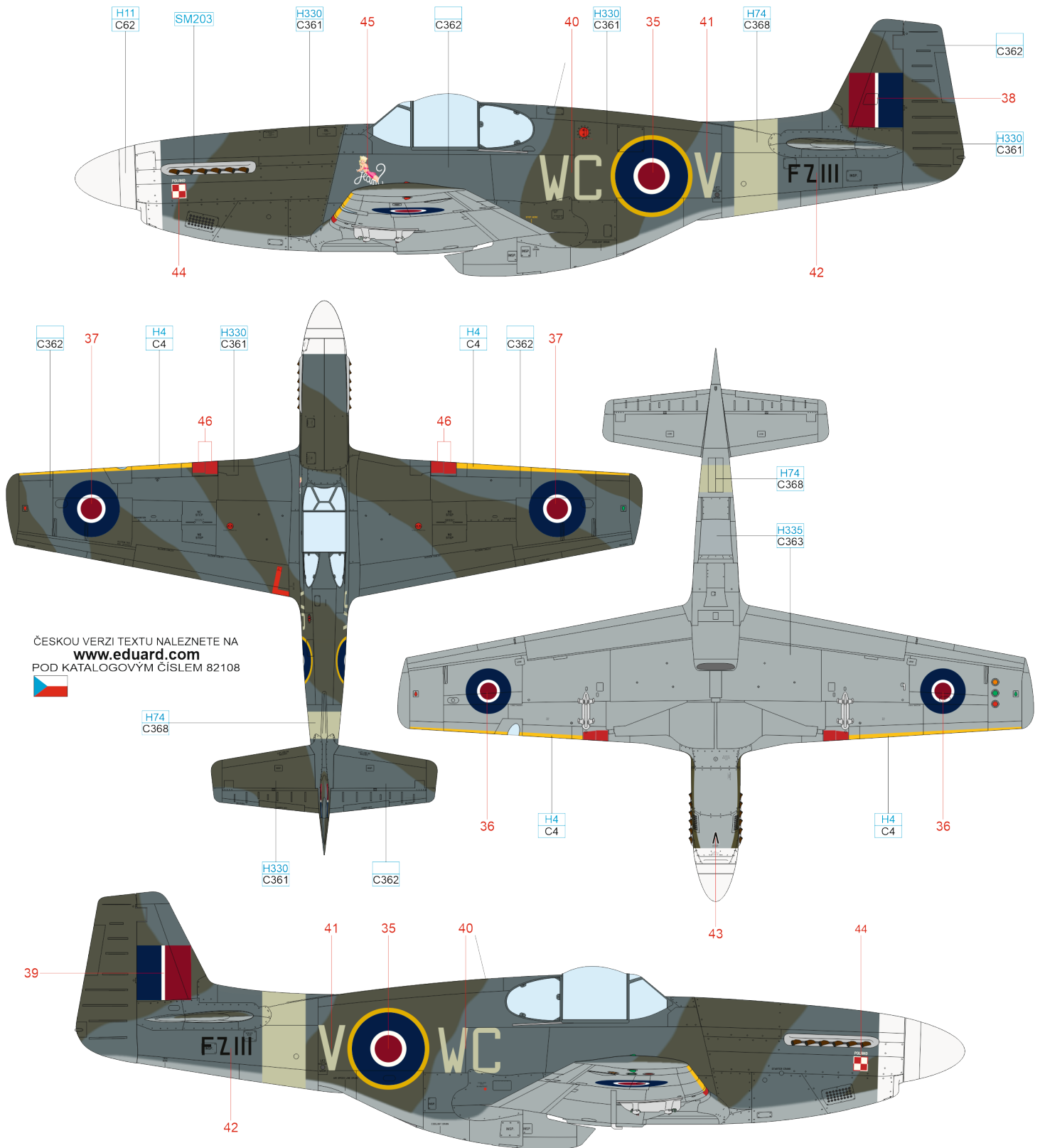

ČESKOU VERZI TEXTU NALEZNETE NA
www.eduard.com
 POD KATALOGOVÝM ČÍSLEM 82108

FLAT WHITE	H11 C62	YELLOW	H4 C4
SKY	H74 C368	MEDIUM SEA GRAY	H335 C363
		OCEAN GRAY	C362
		DARK GREEN	H330 C361
		SUPER IRON 2	SM203

D P-51B-15-NA, s/n 43-24877, Lt. Harold P. Kick, 325th FS, 318th FG, 15th AF, Lesina, Italy, November 1944

The ace with six victories and 325th FS commander Roy Burton Hogg was flying Mustang number 69, named Penrod. Captain Hogg joined the 325th FS in March 1943 and recorded his victories with three different types of aircraft (two with the P-40, two with the P-47 and two with this Mustang). After the unit was partially re-equipped with the new D version Mustangs, Lt. Harold Kick took over the aircraft and renamed it Chinese Laundry. This inscription adorned the left side of the engine cowling, with the great It's a Dog inscription on the right side. It was one of the last three P-51Bs left in service with the 15th AF.

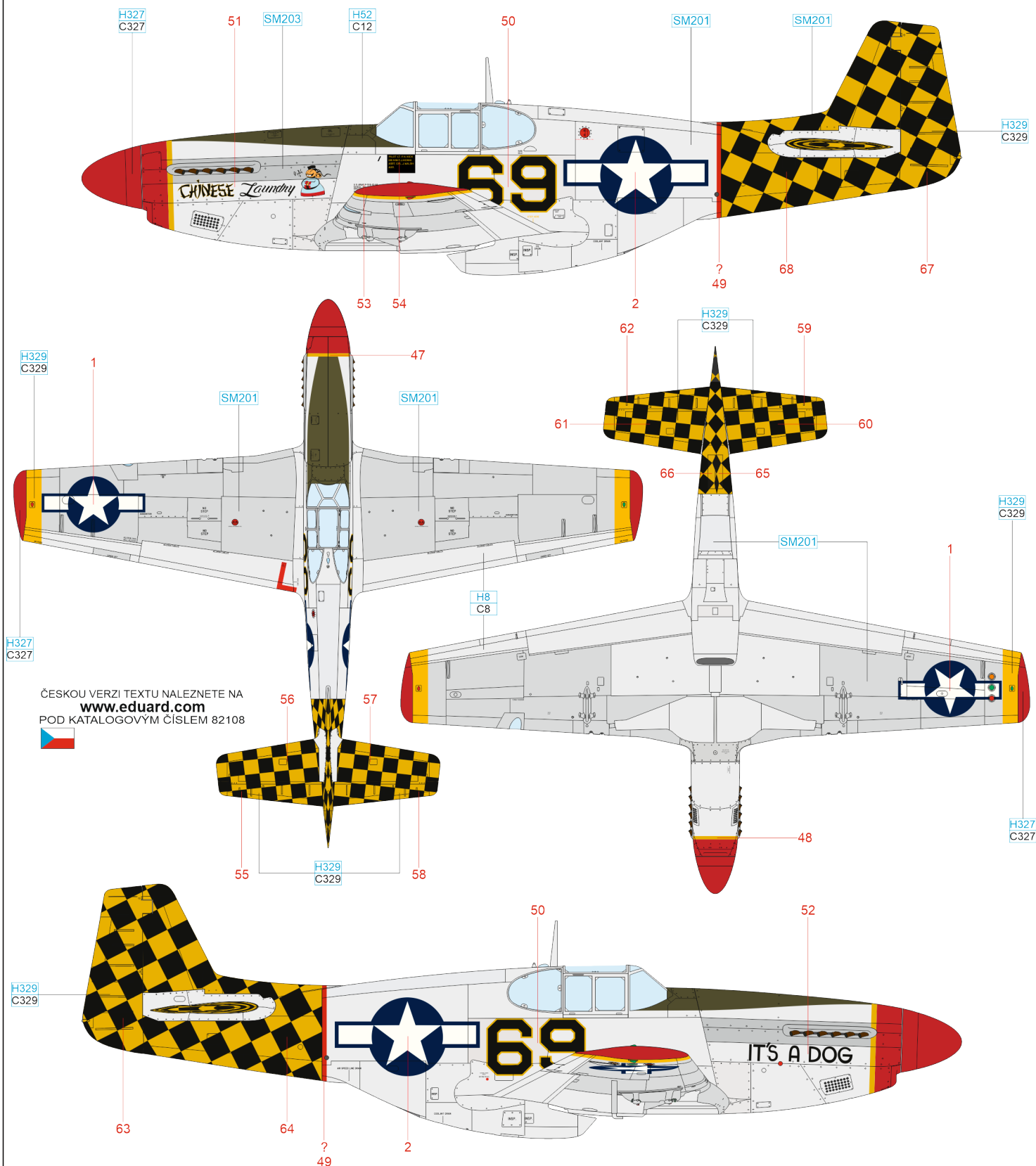

ČESKOU VERZI TEXTU NALEZNETE NA
www.eduard.com
 POD KATALOGOVÝM ČÍSLEM 82108

YELLOW	H329 C329	RED	H327 C327	SUPER FINE SILVER 2	SM201
SILVER	H8 C8	OLIVE DRAB	H52 C12	SUPER IRON 2	SM203

E P-51C-10 NT, s/n 44-11096, 26th FS, 51st FG, 14th AF, Kunming, China, 1944

Mustangs of the 26th FS carried the typical shark's mouth and were often decorated with various inscriptions. The 51st Fighter Group spent most of World War II defending both ends of an air supply route between India and China called The Hump. The unit was activated in January 1941, almost a year before the Americans entered the war. It was one of the first groups sent from the United States to India after the attack on Pearl Harbor. In September 1942, it moved to Dinjan, Assam, and began operations in October. Dinjan was within range of Japanese aircraft, so the 51st FG spent part of the period defending supply routes and its own bases. It also took part in the fighting during the Japanese offensive in northern Burma in 1943. In October 1943, the 51st FG was transferred to the 14th AF in China. Its mission was to defend the Chinese end of The Hump and also to support the Chinese Army. It also carried out attacks on Japanese ships. The unit returned to India in September 1945 and to the United States in November.

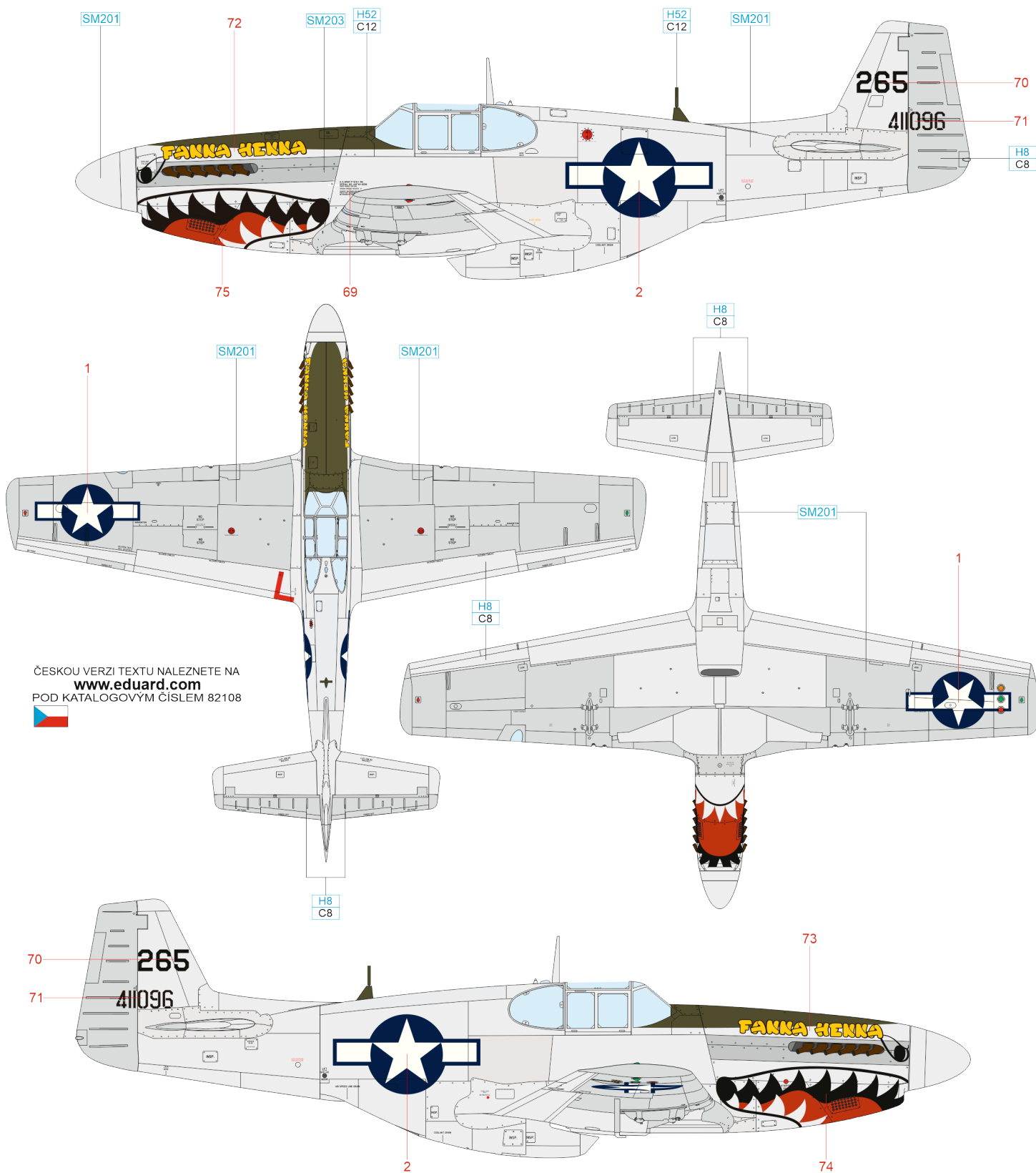

SILVER H8 OLIVE H52 SUPER FINE SILVER 2 SM201 SUPER IRON 2 SM203
C8 DRAB C12

eduard

F P-51C, Lt. G. J. Kaplanek and L. D. Monaghan, 118th TRS, 23rd FG, 14th AF, Chengkung, China, May 1945

The history of the 118th TRS, in the form of the 118th Aero Squadron, began on August 31, 1917, when it flew in France. In 1923, it was redesignated as the 118th Observation Squadron within the Connecticut National Guard. After the Japanese attack on Pearl Harbor, its activities consisted of anti-submarine patrolling off the Atlantic coast. In August 1942, it was withdrawn from that tasking and prepared for deployment overseas. In October 1943, already as the 118th Tactical Reconnaissance Squadron, it was assigned to the 23rd Fighter Group, flying as part of the 14th AF over the CBI (China-Burma-India) area. There it operated first with P-40s in the defense of airfields in India, from which B-29s operated. On its return to the US, it was reassigned to the Connecticut Air National Guard. The unit is still active, now flying as the 118th Airlift Squadron with C-130H Hercules aircraft. The distinguishing feature of the 118th TRS Mustangs was the black, yellow-lined lightning bolt on the fuselage and small lightning bolts on the wing tips. The machine with the number 586 on the stern bore the inscription Dottie N' Butch on the left side of the engine cowl and Roxie on the right side of it. The upper surfaces of the fuselage and wings were camouflaged with Olive Drab paint and the surface was heavily weathered.

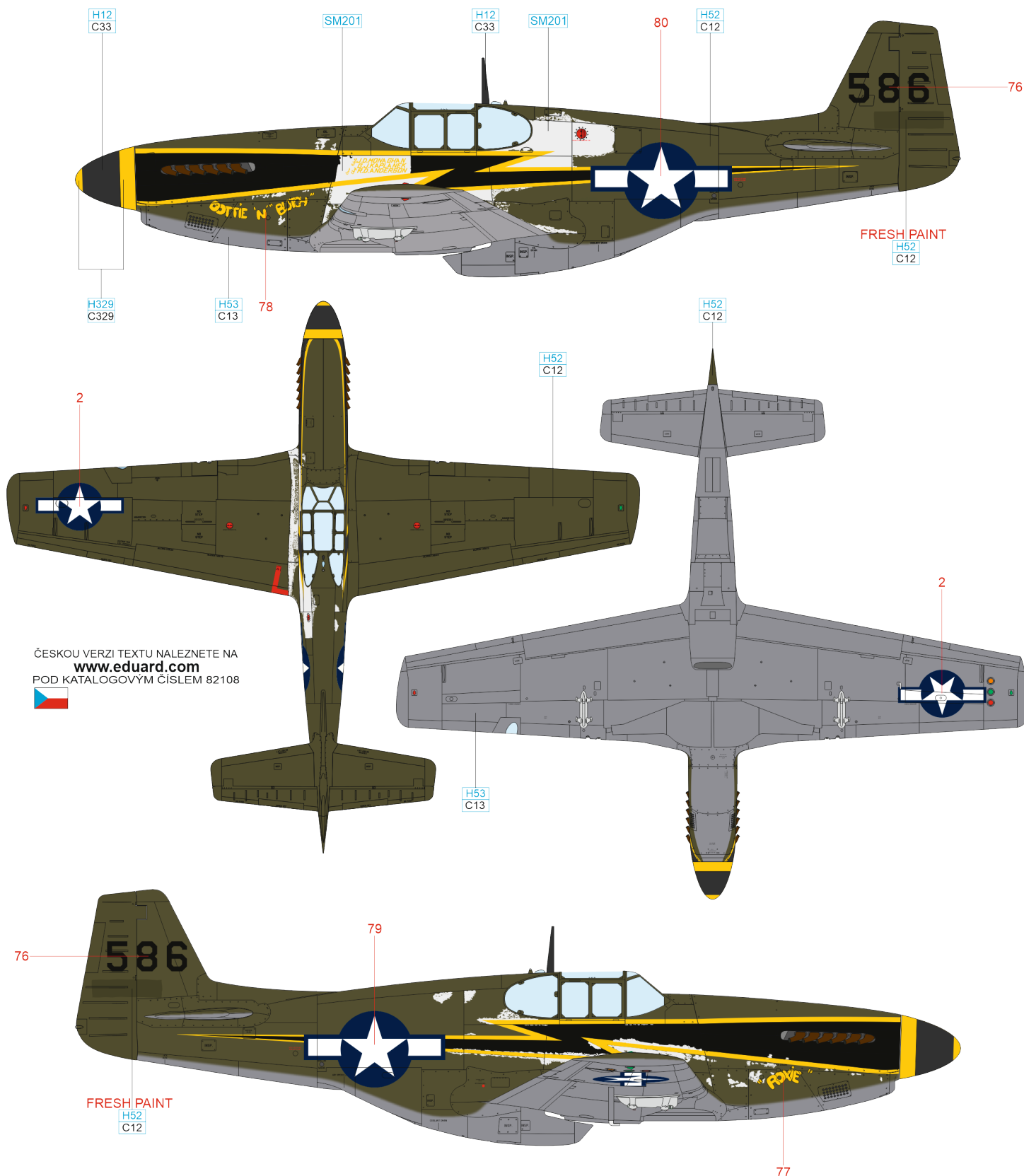

ČESKOU VERZI TEXTU NALEZNETE NA
www.eduard.com
 POD KATALOGOVÝM ČÍSLEM 82108



OLIVE DRAB H52 C12 NEUTRAL GRAY H53 C13 YELLOW H329 C329 FLAT BLACK H12 C33 SUPER FINE SILVER 2 SM201

