

Bf 109G-6 late series

eduard

GERMAN WWII FIGHTER

1/48 SCALE PLASTIC KIT

ProfiPACK
edition

#82111



INTRO

No other aircraft of the German Luftwaffe is so intimately connected with its rise and fall in the course of the Second World War than the Messerschmitt Bf 109. This type, by whose evolution outlived the era in which it was conceptualized, bore the brunt of Luftwaffe duties from the opening battles of Nazi Germany through to her final downfall. The history of the aircraft begins during 1934-35, when the Reich Ministry of Aviation formulated a requirement for the development of a single-engined monoplane fighter. Proposals were submitted by Arado, Heinkel, Focke-Wulf and Bayerische Flugzeugwerke. The last mentioned firm featured a technical director named Professor Willy Messerschmitt, who was riding a wave of popularity based on the success of his recent liaison aircraft, the Bf 108. His goal was to conceive of an aircraft with the best possible performance for the specified weight, size, and aerodynamic qualities. Over the subsequent months, several prototypes were built that served first and foremost in development flights and further modifications. The aircraft was relatively small, and compared to the prevailing trends of the time, docile with revolutionary features such as low wing design, the use of a retractable landing gear, a wing with a very narrow profile, wing slats, landing flaps, weapons firing through the prop hub, and so on. Even the enclosed cockpit and the method of construction were not very common just four years prior to the beginning of the Second World War. At its conception, the Bf 109 was a very promising asset despite some powerplant troubles. These were solved by the introduction of the DB 601. This engine, together with its extrapolated development DB 605, is umbilically connected to the types success. These two-row, twelve cylinder inverted V engines powered several tens of thousands of 109s in over 25 versions and variants.

The first combat use was by three developmental Bf 109s in the Spanish Civil War, where they were delivered in December 1936. The pre-series airframes were to, first of all, validate the aircraft's abilities in modern aerial combat. Shortly thereafter, production machines in the form of the Bf 109B-1 began to reach 2./J/88, the Legion Condor. The desire of Germany to demonstrate her aerial prowess to potential foes was advanced further in international sport meets. The triumphs attained in Zurich in the summer of 1937 were complemented several months later by grabbing the speed record of 610.95 kph. In very short order, the progressive developments represented by the C, D and E versions appeared. Despite this, the delivery of the types to combat units did not sustain a rate that was desired by military brass. Even by August 1938 the Bf 109 accounted for less than half of the 643 front line fighters in service. The later months saw an increase in these rates. By the time of the invasion of Poland (which saw the participation of only a little more than 200 aircraft) the Luftwaffe possessed the best fighter produced in continental Europe. With both a qualitative and quantitative advantage, the fighter wing of the Luftwaffe entered the Polish campaign, the first defenses of the Fatherland, Blitzkrieg against the West, and the Battle for France. With one foot in the door that was the English Channel, the Luftwaffe embarked on the attacks on Britain in the summer months of 1940. Here, the first weakness of the Bf 109 was revealed: the inability to carry drop tanks that would have enabled the type to effectively escort bombers to England. This was one of the factors that made the defeat of the Luftwaffe in the Battle of Britain possible. Experiences gained in 1940 led to the development of the 'F' version prior to the spring of 1941. The elegance of the Bf 109 crested with the 'Friedrich'. Following a largely defensive stance over the Channel and northern France, the Bf 109F took on a more offensive role in Operation Barbarossa in the east, and in northern Africa. In later duties with the 'Jagdwaaffe' during the second phase of the war in the east, and in the 'Defense of the Reich' from 1943 to 1945, the Bf 109 served in the form of the 'G' version, followed by the 'K'. Even if by the end of the war it was clear that the development of the Bf 109 was exhausted, during its combat career, the type was able to keep pace with the foes that it encountered. Besides its primary function as fighter, the Bf 109 also appeared as a fighter-bomber, reconnaissance platform, night fighter, trainer and rammjäger.

The disappearance of the Bf 109 from the skies over Europe was not spelled out by the end of the war. Several examples were in Swiss service up to 1949, and many flew in the air force of Czechoslovakia in both original form with a DB 605 powerplant and as aircraft built out of necessity with surplus Jumo 211s. The latter type also served as the first fighter to fight for the independence of the newly formed state of Israel. Finland retired the type as recently as 1954, and Spain didn't retire its HA-1109-1112, re-engined Bf 109s, until 1967. The legendary low-wing fighter of Professor Willy Messerschmitt survived the state that developed it.

ÚVODEM

Žádný jiný stroj německé Luftwaffe není výrazněji spojen s jejím vzestupem a pádem ve 2. světové válce, než stíhací Messerschmitt Bf 109. Letoun, který svou koncepcí výrazně předběhl dobu, ve které vznikl, se stal tahounem stíhacího letectva od prvních válečných konfliktů nacistického Německa, až do jeho hořkého konce. Historie letounu se začíná v období let 1934-35, kdy Říšské ministerstvo letectví formulovalo specifikace zakázky na vývoj jednomotorové jednoplošné stíhačky. Projektu se zúčastnily firmy Arado, Heinkel, Focke-Wulf a Bayerische Flugzeugwerke. V poslední jmenované působil na postu technického ředitele profesor Willy Messerschmitt, jehož popularita se nesla na vlně úspěchu nedávno dokončeného kurýrního Bf 108. Jeho cílem bylo vytvořit letoun s co největším poměrem výkonu k celkové hmotnosti, velikosti a aerodynamickým vlastnostem. V průběhu následujících měsíců vzniklo několik prototypů, které sloužily zejména ke zkouškám a dalšímu vývoji. Letoun byl poměrně malý, oproti stávajícím zvyklostem relativně jemný, s revolučními konstrukčními prvky jako byla dolnokřídla koncepce, použití zatahovacího podvozku, křídlo s velmi štíhlým profilem, pohyblivé sloty, vztlakové klapky, zbraně střelící osou vrtule, atd.

Dokonce uzavíratelný překryt kabiny nebo skofepinová konstrukce nebyly čtyři roky před začátkem 2. světové války tak obvyklým jevem, jak by se z dnešního pohledu mohlo zdát. Bf 109 byl již z počátku svého vývoje, i přes problémy s pohonnou jednotkou, velmi nadějným projektem. Problémy s pohonem vyřešila až zástavba motoru DB 601. Ten je spolu s pozdějším DB 605 neodmyslitelně spojen s úspěchy Bf 109. Řadový invertní dvanáctiválec do V poháněl několik desítek tisíc vyprodukovaných „stodevíték“ ve více než 25 verzích a variantách. K prvnímu bojovému nasazení tří zkušebních kusů Bf 109 došlo za občanské války ve Španělsku, kam byly odeslány v prosinci 1936. Stroje z před sériové výroby měly především ukázat schopnosti letounu v moderní letecké válce. Následně se do bojového nasazení u 2./J/88 Legion Condor začaly dostávat i sériové stroje varianty Bf 109B-1. Snaze Německa ukazovat svou leteckou sílu potenciálním protivníkům napomáhala i sportovní klání. Triumf letounů Bf 109 na leteckém mítinku v Curychu v létě 1937 byl doplněn o několik měsíců později ustanovením rychlostního rekordu 610,95 km/h. Ve velmi krátkých časových úsecích následovaly verze C, D a E. Přesto však doplňování nových strojů k bojovým útvarům nepokračovalo tempem, který by si velení mohlo přát. Ještě v srpnu roku 1938 tvořila výzbroj letouny Bf 109 méně než polovinu z 643 stíhačů první linie. Ovšem během následujících měsíců roku se tempo dodávek k bojovým útvarům zrychlilo. V okamžik přepadení Polska (kterého se však zúčastnilo jen o málo více než dvě stě Bf 109) tak Luftwaffe disponovala zajisté nejlepší stíhačkou, jaká byla v kontinentální Evropě vyrobena. S technickou i množství převahou tak stíhací část Luftwaffe absolvovala polskou kampaň, první obranu Vatanlandu, Blitzkrieg proti západu i bitvu o Francii. S jednou nohou vykročenou přes kanál La Manche zahájila Luftwaffe v letních měsících roku 1940 útoky na Británii. V tu dobu se mj. projevil jeden vážný nedostatek Bf 109 - nepřipravenost konstrukce stroje na nesení přídavné nádrže, která by zvýšila dolet letounu při doprovodu bombardérů nad Británií. Tato zdánlivá maličkost byla jedním z faktorů, které zapříčinily porážku Luftwaffe v Bitvě o Británii. Zkušenosti z bojů v r. 1940 napomohly při vývoji verze F, která se začala k bojovým útvarům dostávat během předjaří 1941. Elegance Bf 109 u „Friedricha“ dosáhla vrcholu. Po bojích nad Kanálem a severní Francií, spíše již defenzivního charakteru, se Bf 109F zapojily i do útočných akcí, a to zejména při operaci Barbarossa na východě nebo v severní Africe. Do pozdějších úkolů Jagdwaaffe ve druhé fázi války na východě i do obrany Říše v letech 1943 - 1945 se zapojovaly především Bf 109 verze G a v posledních měsících války pak také verze K. Ačkoli na konci války bylo jasné, že koncepce letounu Bf 109 se po deseti letech služby dostala na hranici možností, po celou dobu své bojové činnosti dokázaly jednotlivé varianty držet krok se svými stíhacími protivníky. Kromě svého prioritního určení stíhacího letounu se Bf 109 objevily i v rolích stíhací-bombardovací, průzkumná, noční stíhací, palubní stíhací, cvičné nebo jako rammjäger.

Nebe se pro Bf 109 nezavřelo ani po skončení války. Několik strojů sloužilo až do roku 1949 ve Švýcarsku, mnohé létaly v balkánských zemích, v osvobozeném Československu, a to jak v původní podobě s motory DB 605, tak v přestavěné variantě s motory Jumo 211. Zejména tyto stroje později tvořily základ letectva bráničů svobodu nově budovaného státu Izrael. Finsko zrušilo Bf 109 až v roce 1954 a Španělsko opustilo své HA-1109 a 1112 dokonce až v roce 1967.



Carefully read instruction sheet before assembling. When you use glue or paint, do not use near open flame and use in well ventilated room. Keep out of reach of small children. Children must not be allowed to suck any part, or pull vinyl bag over the head.



Před započítím stavby si pečlivě prostudujte stavební návod. Při používání barev a lepidel pracujte v dobře větrané místnosti. Lepidla ani barvy nepoužívejte v blízkosti otevřeného ohně. Model není určen malým dětem, mohlo by dojít k požití drobných dílů.

INSTRUCTION SIGNS * INSTR. SYMBOLS * INSTRUKTION SINNBILDEN * SYMBOLES * 記号の説明



OPTIONAL
VOLBA



BEND
OHNOUT



OPEN HOLE
VYVRTAT OTVOR



SYMMETRICAL ASSEMBLY
SYMETRICKÁ MONTÁŽ



REMOVE
ODŘÍZNOUT



REVERSE SIDE
OTOČIT



APPLY EDUARD MASK
AND PAINT
POUŽÍT EDUARD MASK
NABARVIT

PARTS



DÍLY



TEILE



PIÈCES



部品

PLASTIC PARTS

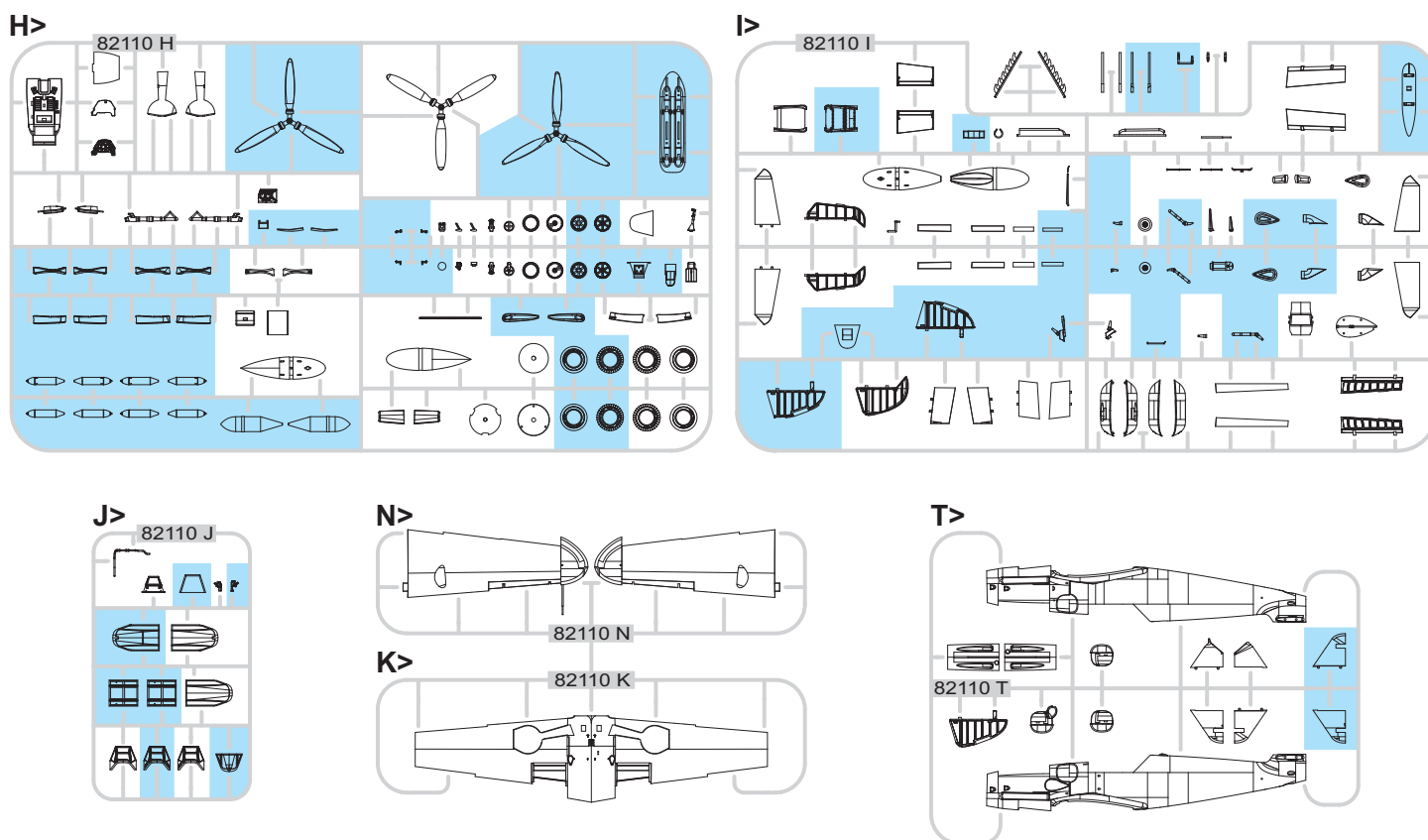

eduard
MASK

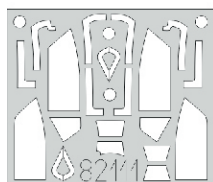

PE - PHOTO ETCHED DETAIL PARTS

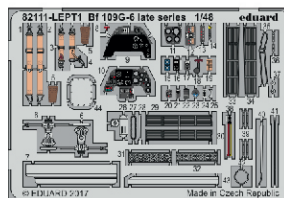

-Parts not for use. -Teile werden nicht verwendet. -Pièces à ne pas utiliser. -Tyto díly nepoužívejte při stavbě. - 使用しない部品

COLOURS



BARVY



FARBEN



PEINTURE



色

GSI Creos (GUNZE)			
AQUEOUS	Mr.COLOR		
H2	C2	BLACK	
H8	C8	SILVER	
H11	C62	WHITE	
H12	C33	FLAT BLACK	
H25	C34	SKY BLUE	
H26	C66	BRIGHT GREEN	
H47	C41	RED BROWN	
H65	C18	BLACK GREEN	RLM70
H68	C36	DARK GRAY	RLM74
H69	C37	GRAY	RLM75

AQUEOUS	Mr.COLOR		
H70	C60	GRAY	RLM02
H77	C137	TIRE BLACK	
H90	C47	CLEAR RED	
H94	C138	CLEAR GREEN	
H413	C113	YELLOW	RLM04
H414	C114	RED	RLM23
H416	C116	BLACK GRAY	RLM66
H417	C117	LIGHT BLUE	RLM76
Mr.METAL COLOR			
MC213		STAINLESS	
MC214		DARK IRON	

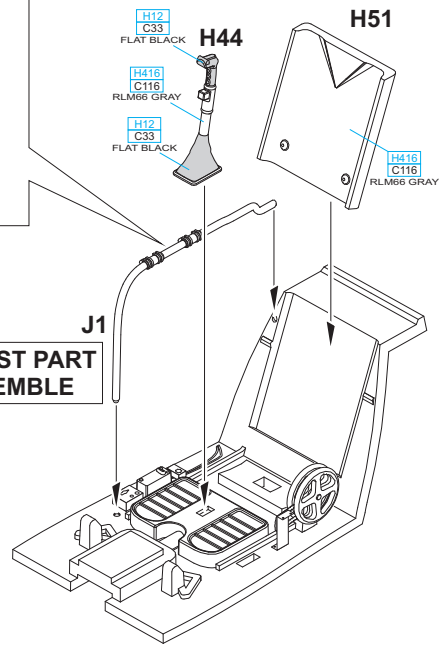
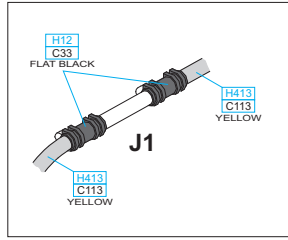
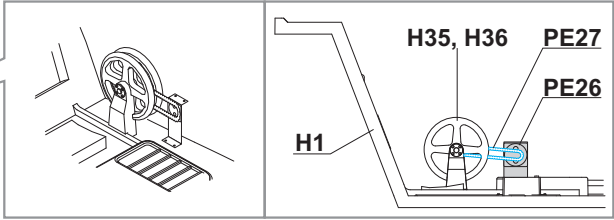
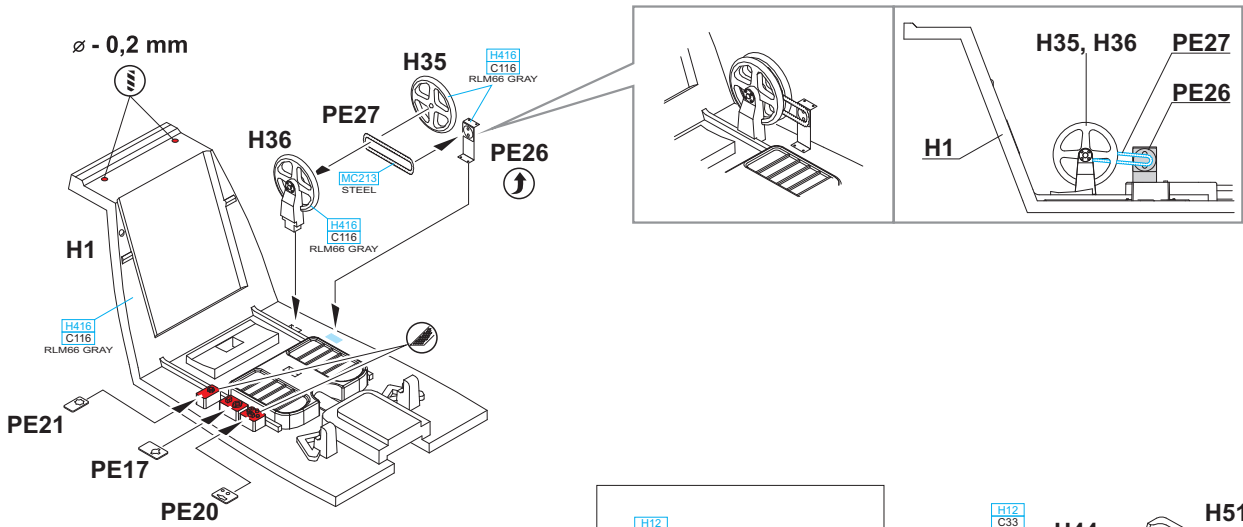

THE LATEST PART TO ASSEMBLE

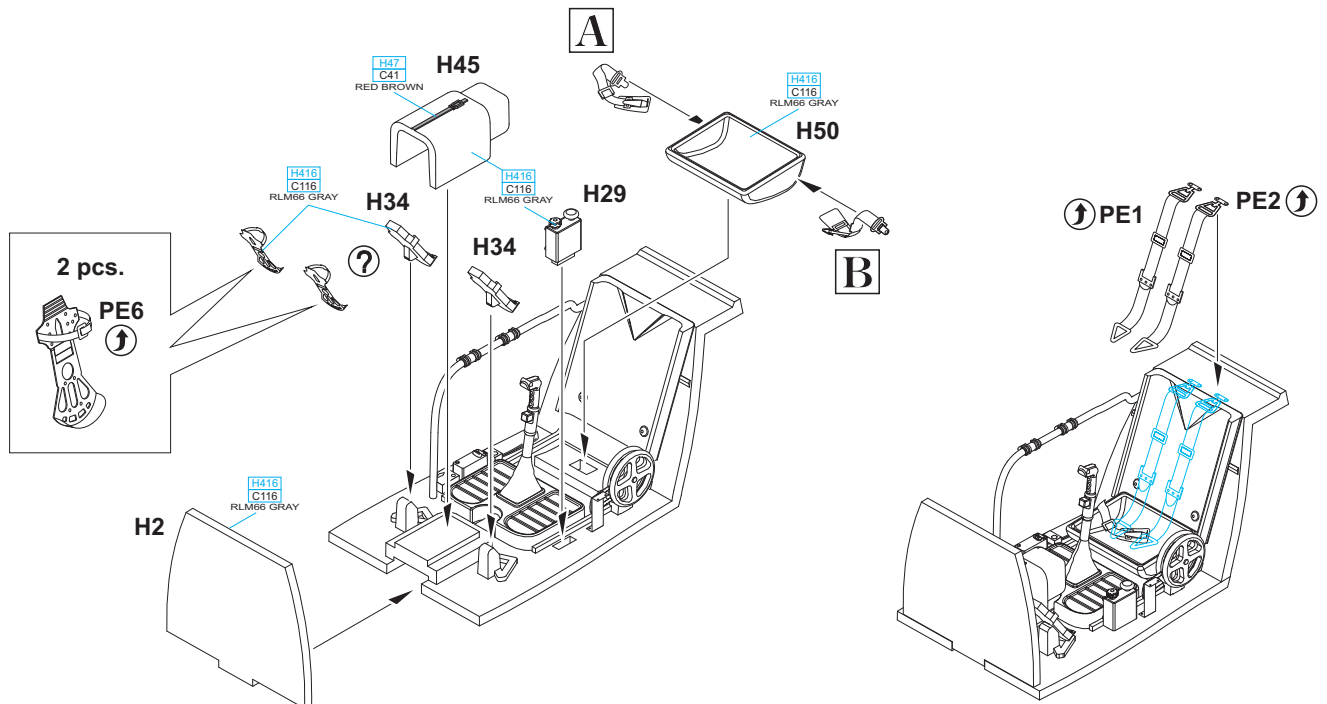
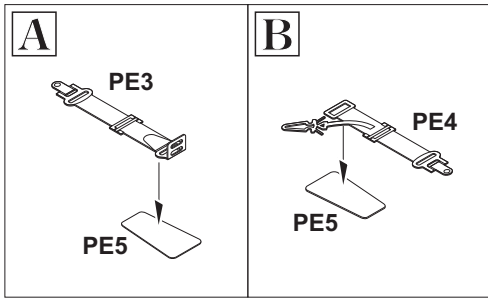

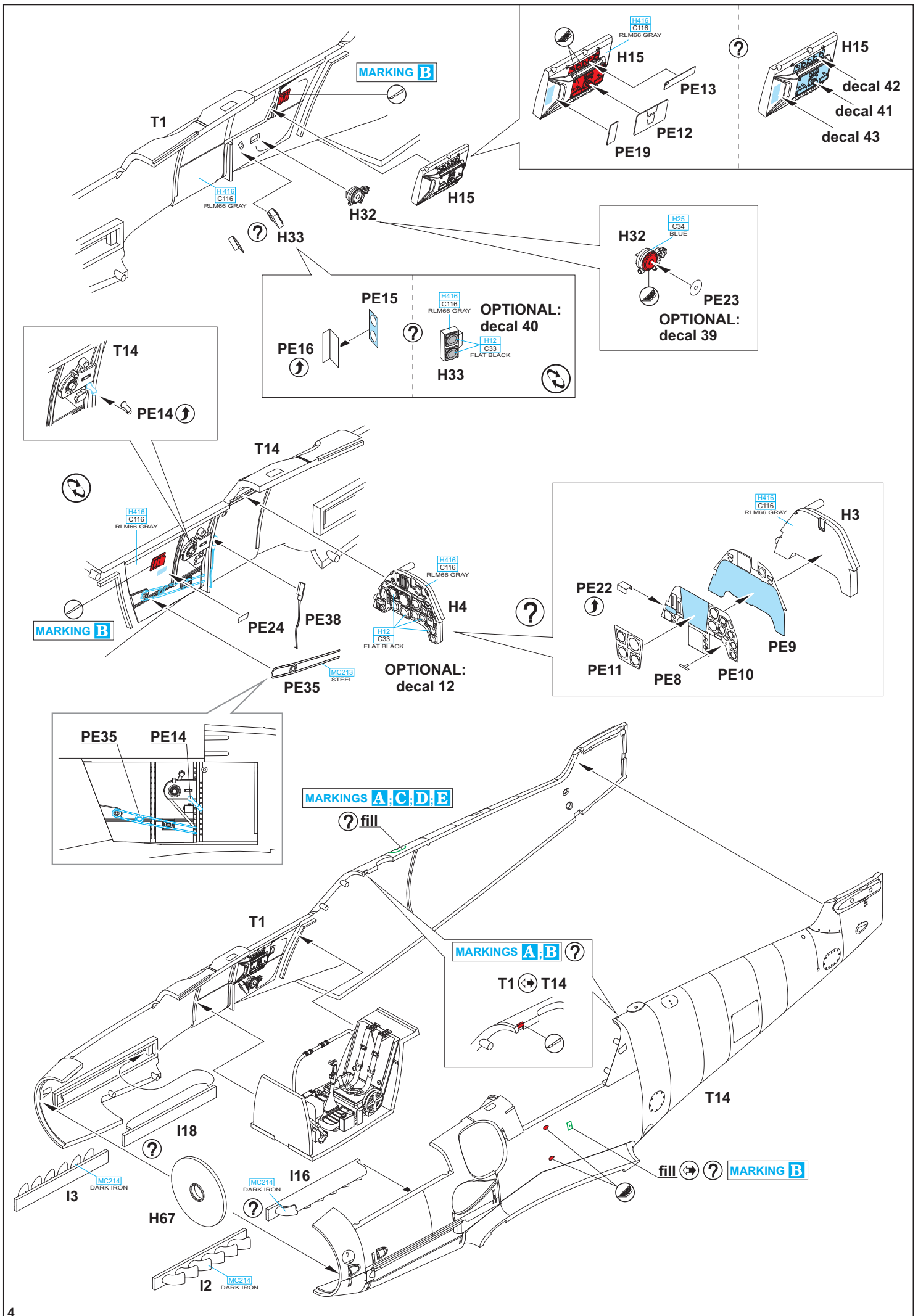

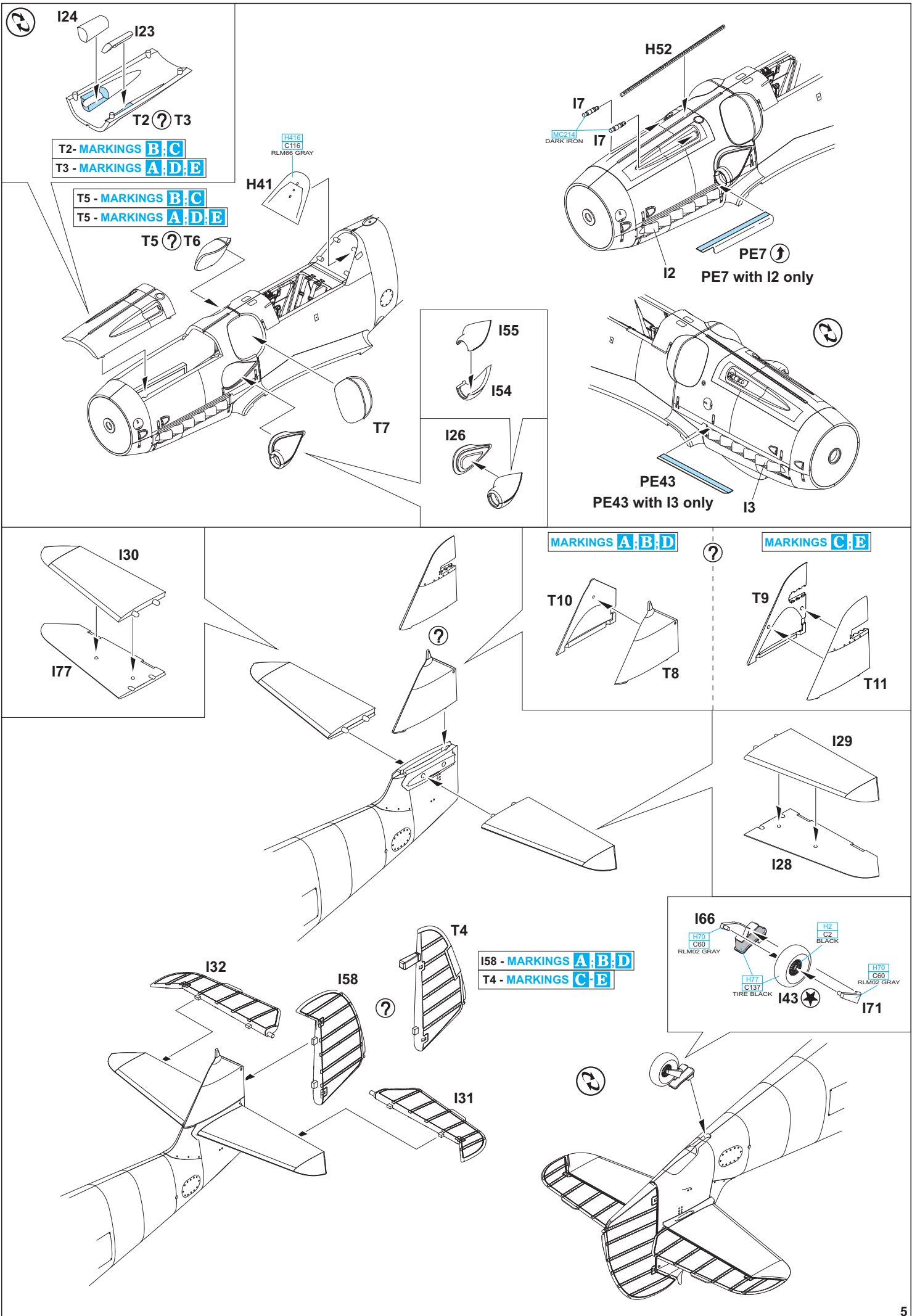

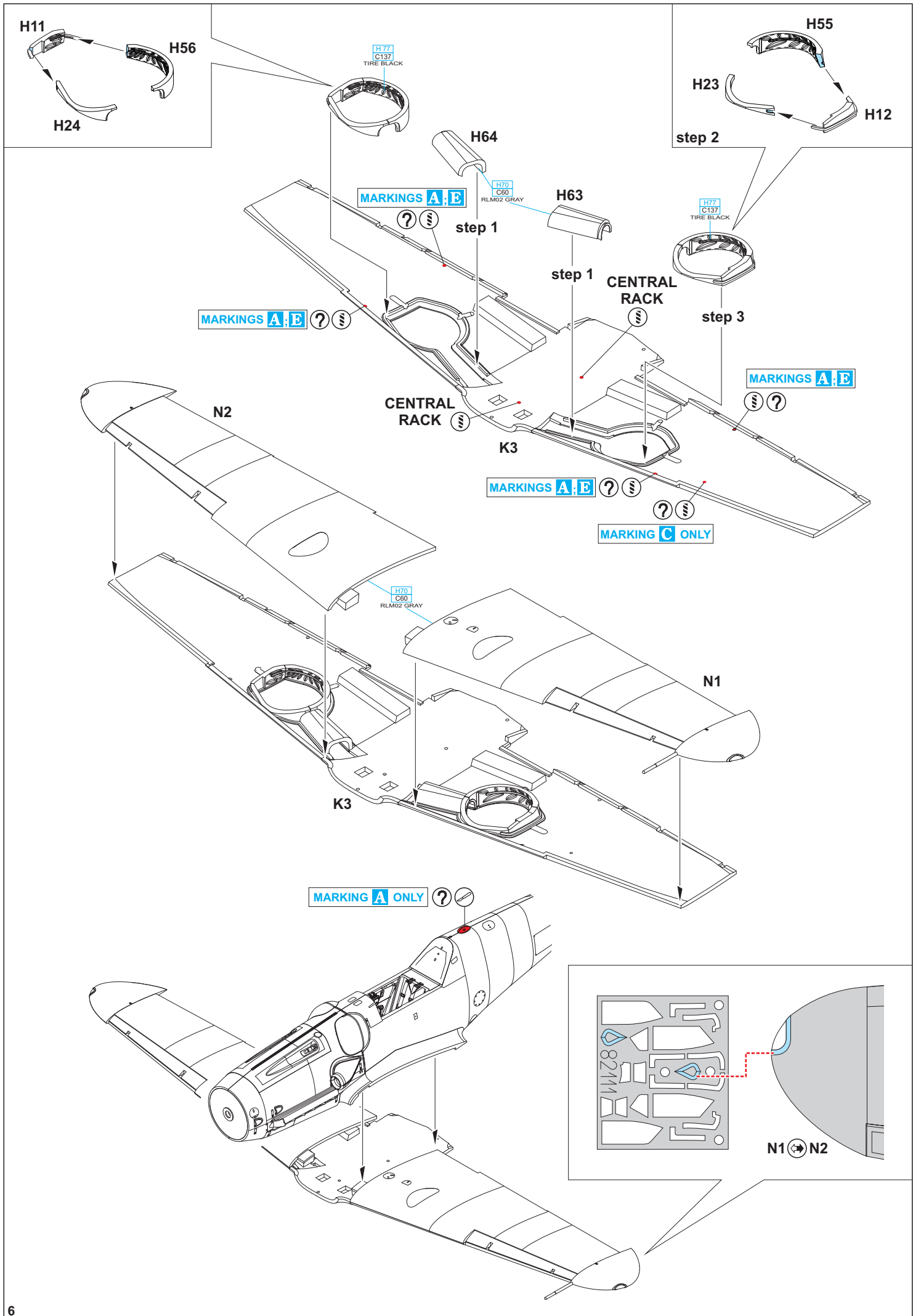

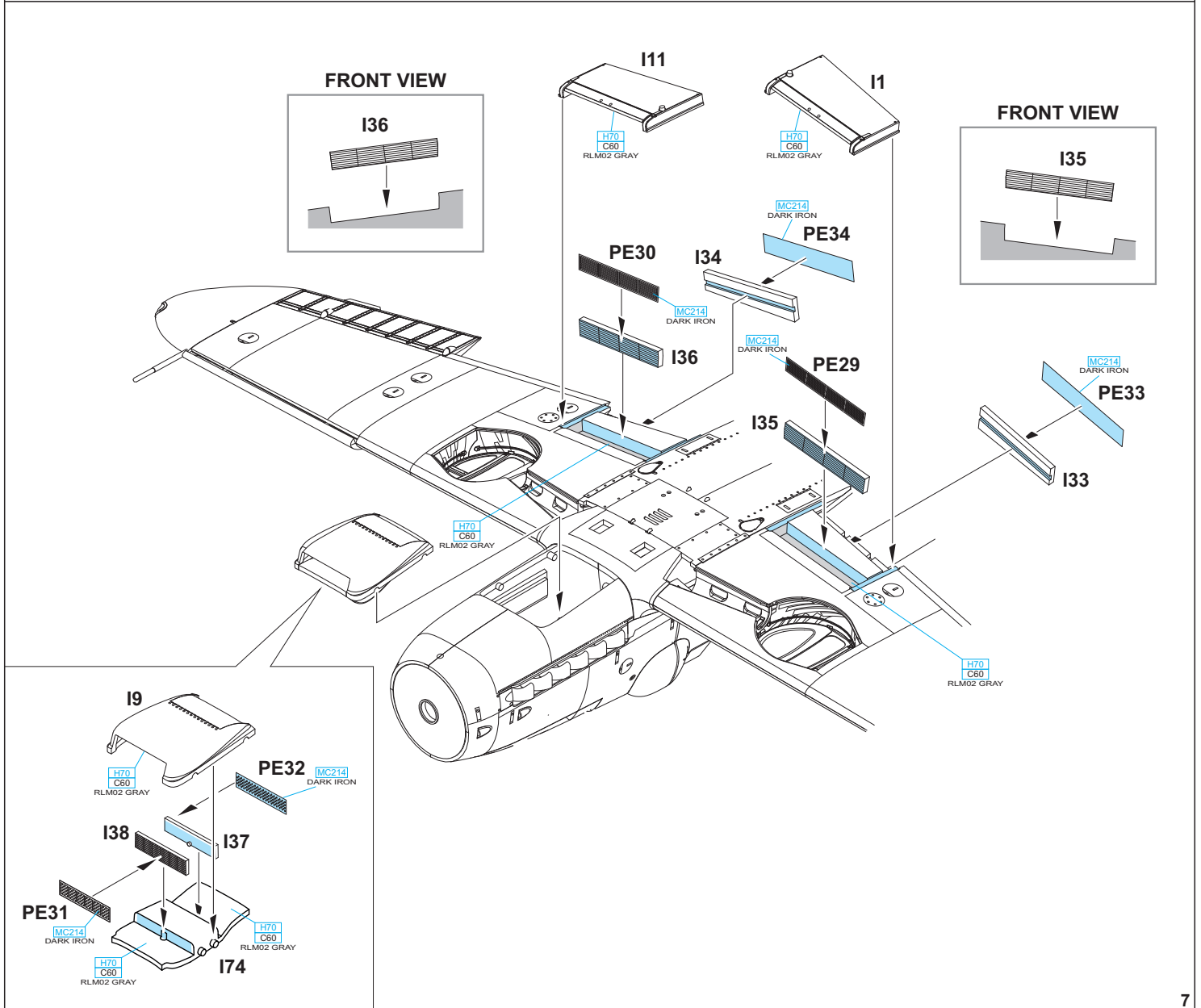
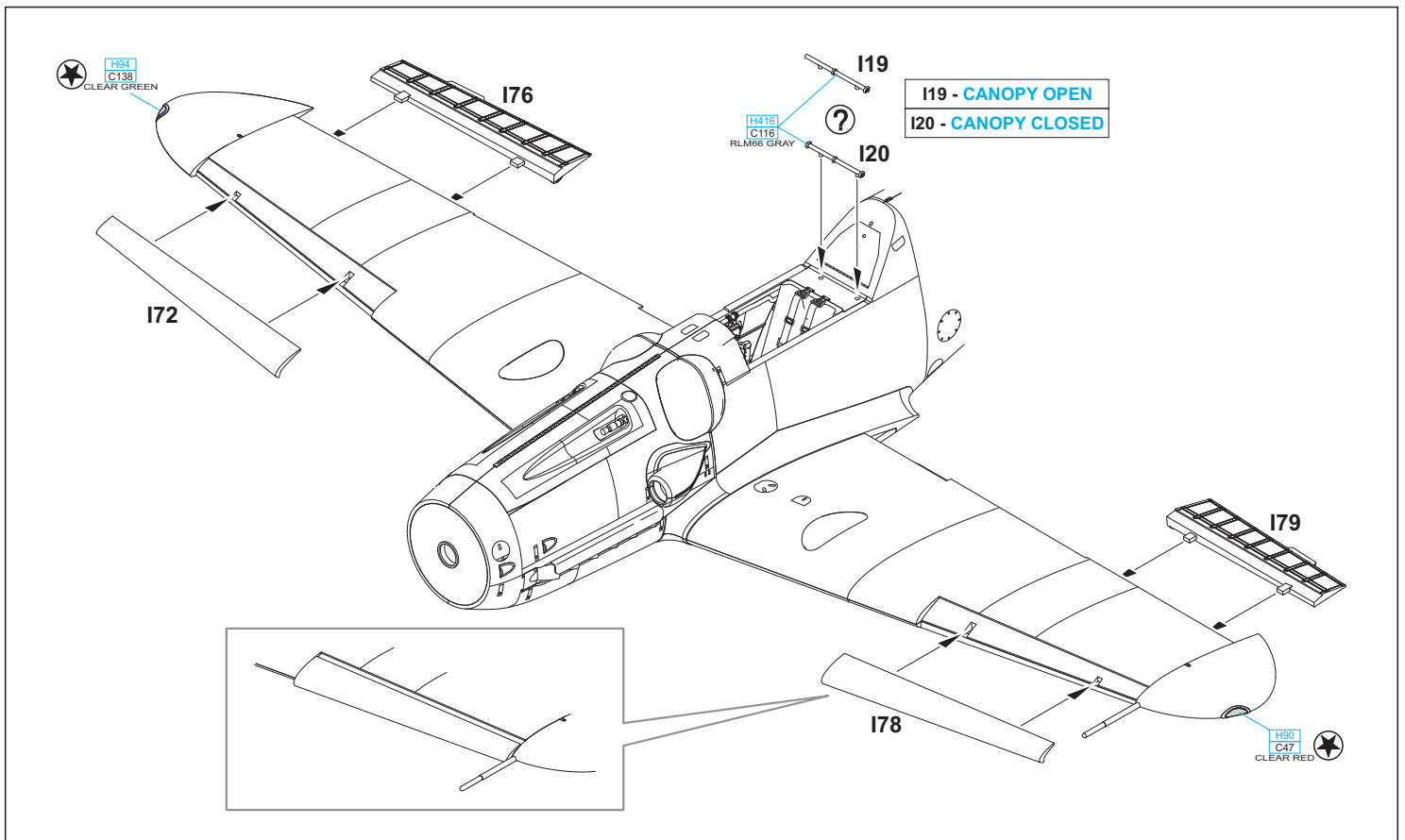

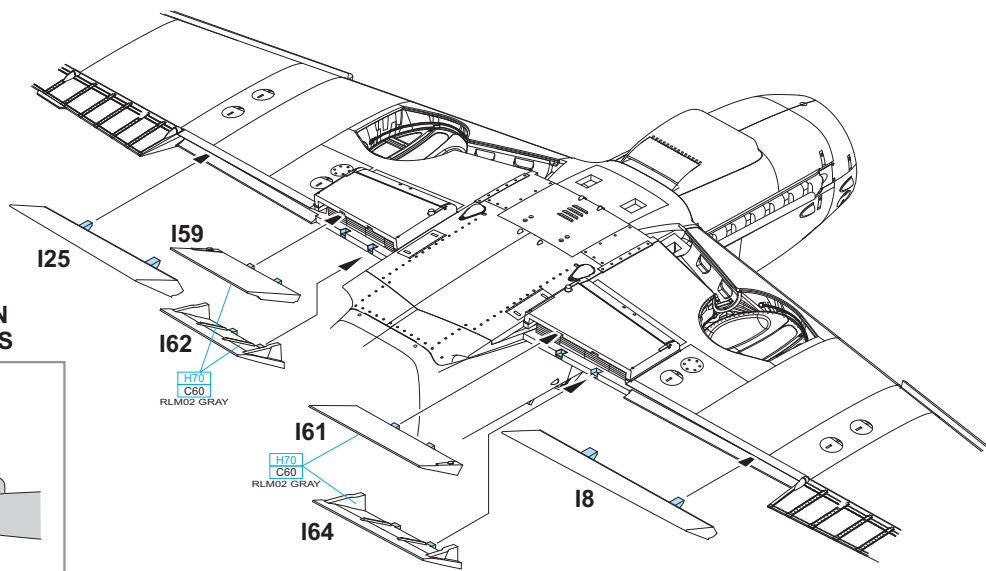

CORRECT POSITION OF RADIATOR FLAPS

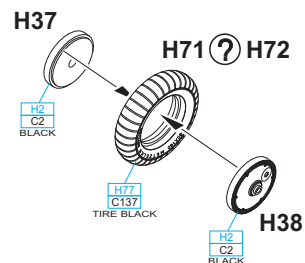
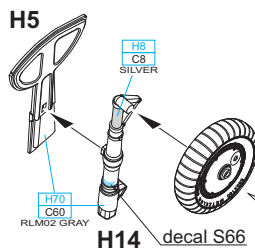
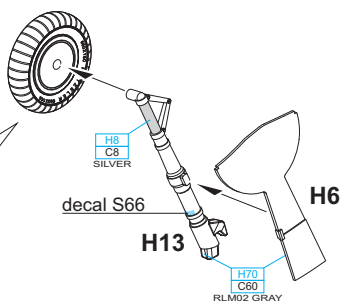
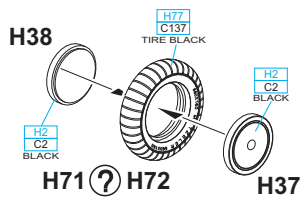
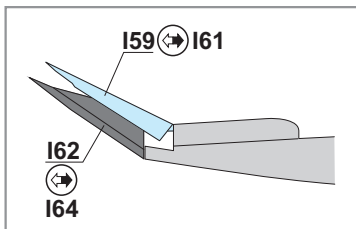

I17 ? PE40 - MARKING C ONLY

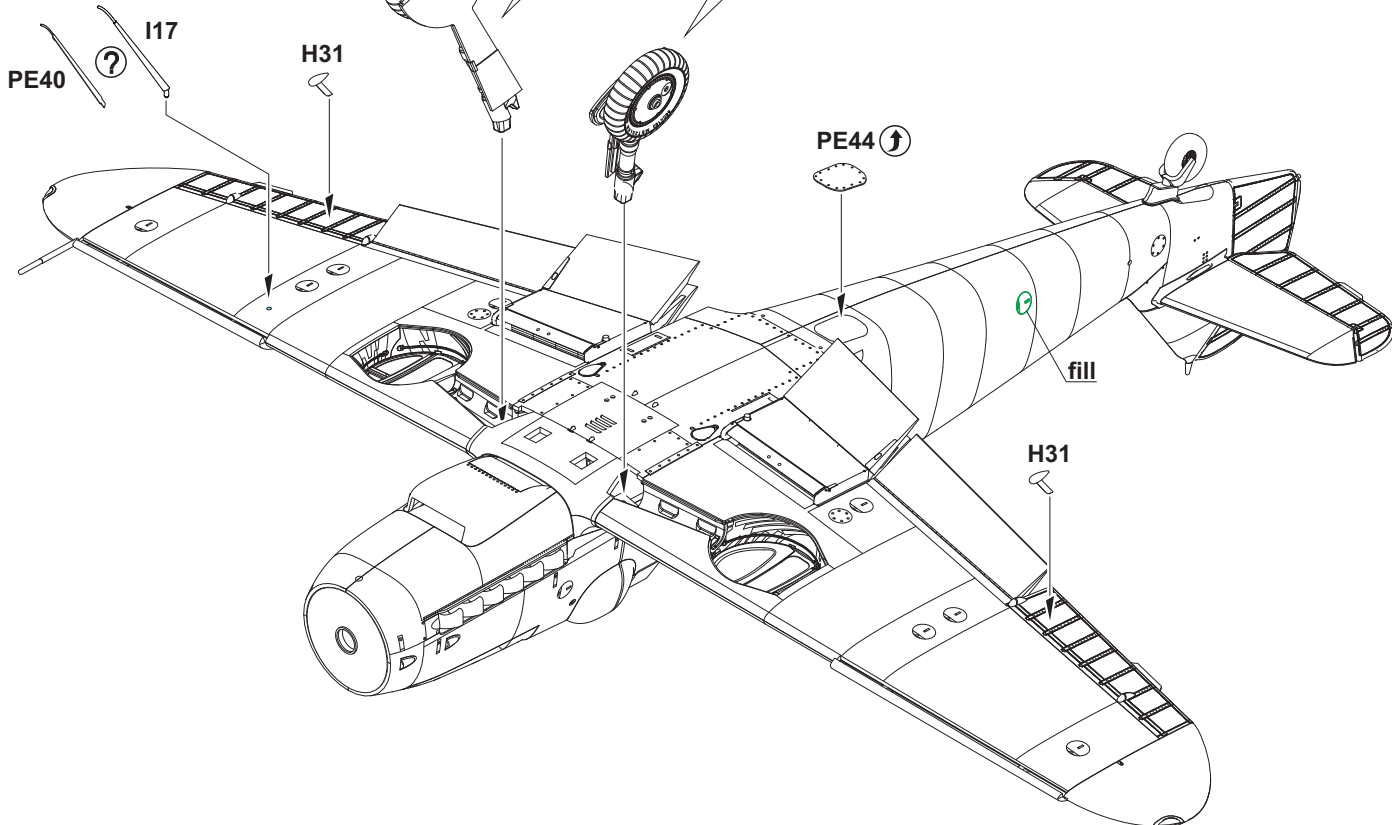

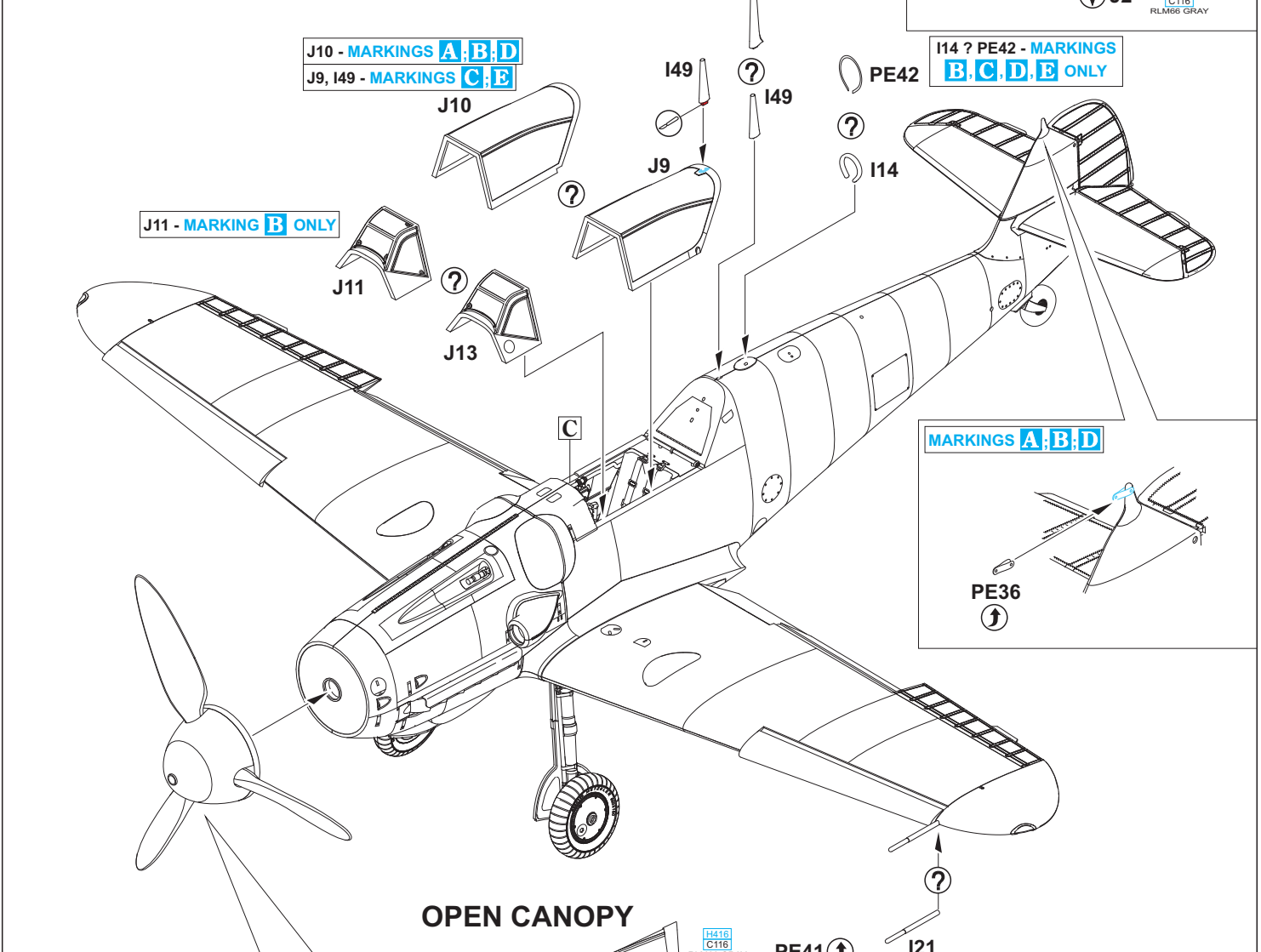
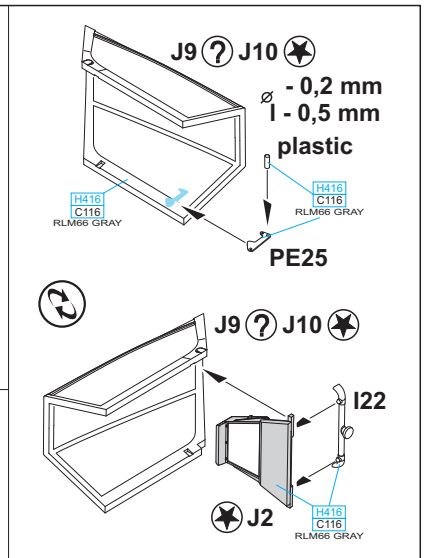
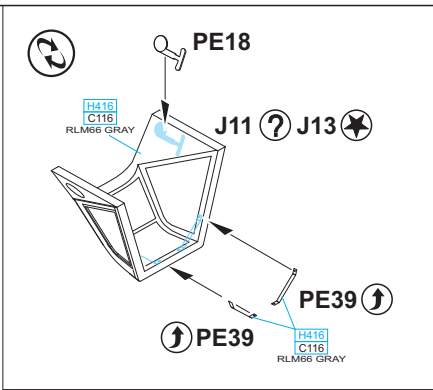
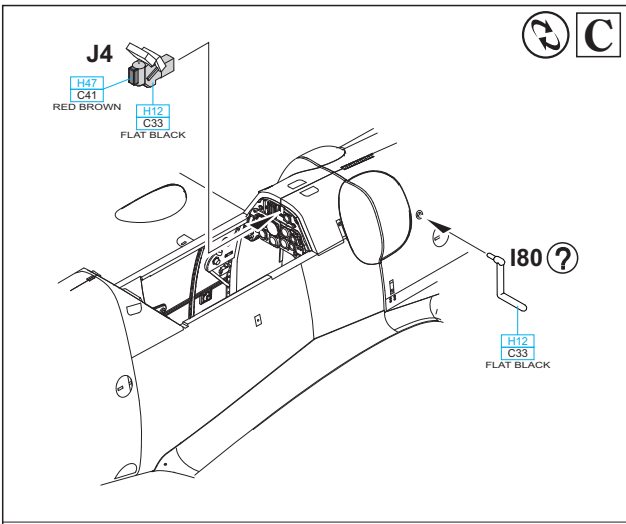

OPEN CANOPY

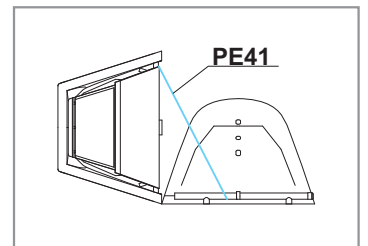
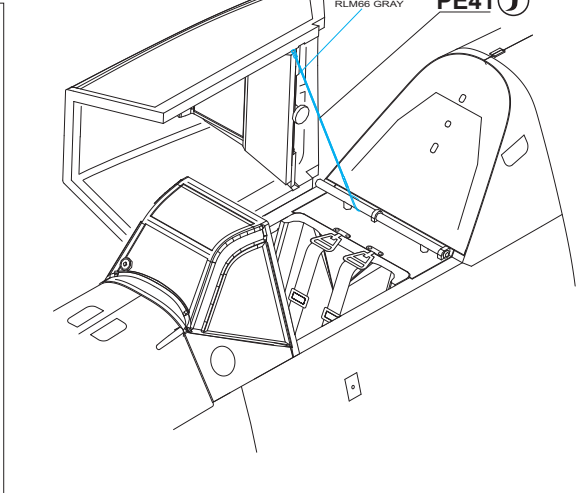
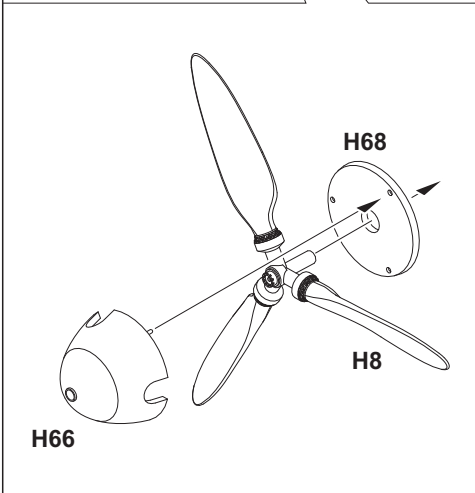

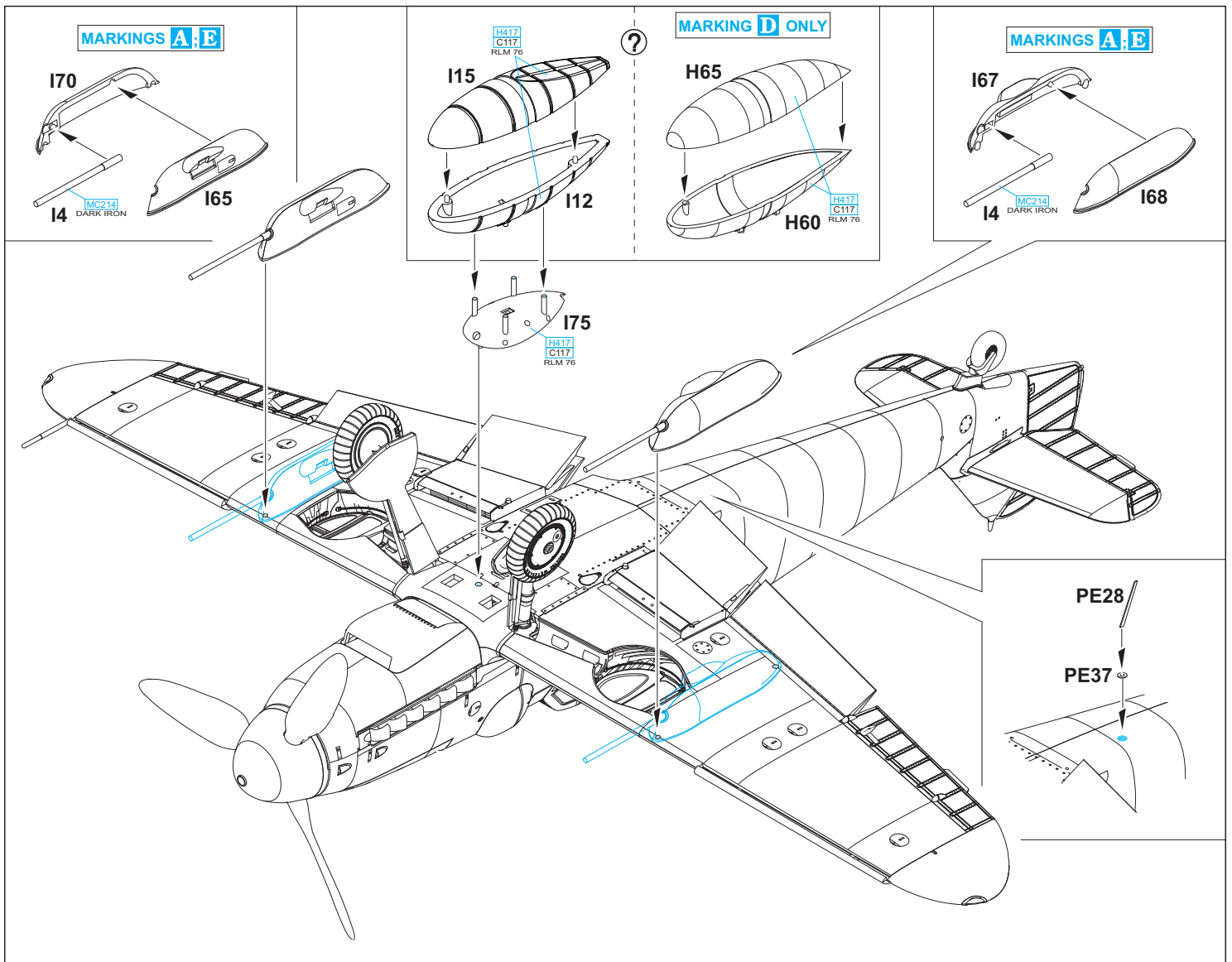

eduard
MASK
82111

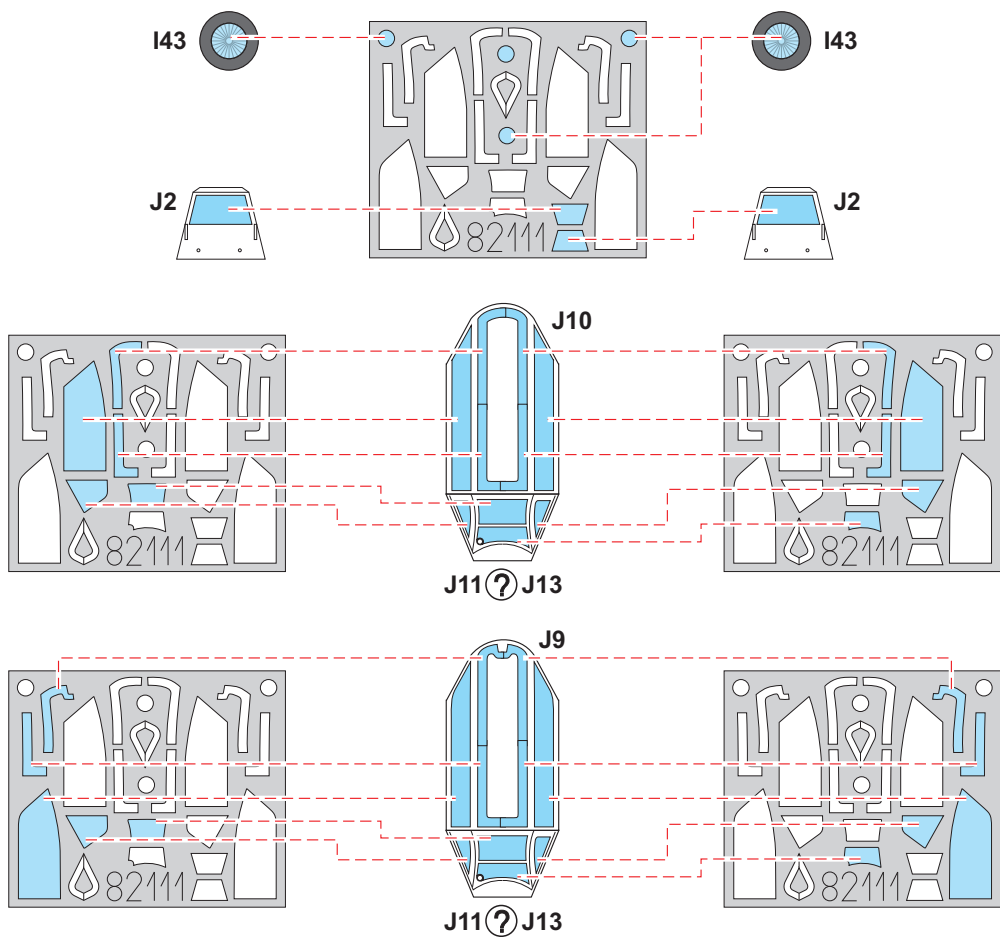
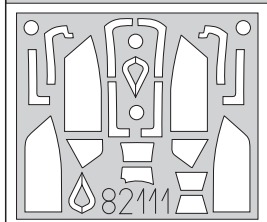

A W.Nr.160303, flown by Hptm. Friedrich Eberle, the CO of III./JG 1, Volkel, November, 1943

Friedrich Eberle, the commanding officer of III. Gruppe of JG 1, was downed in this Bf 109G-6 on January 30, 1944. The man who recorded the kill was a P-47D Thunderbolt jockey, Lt. Robert Booth, of the 369th FS / 359th FG, a fighter ace with a total of eight kills to his credit. Booth himself was downed a few months later, on June 8, 1944 and became a POW. Eberle was injured but survived the encounter with Booth and led III. Gruppe until April 27, 1944. In July 1944, he was appointed the CO of III./JG 4. Eberle led his unit in Operation Bodeplatte, the attack on Allied airfields on January 1, 1945. He was court martialled for cowardice but finally was acquitted of the charge and survived the war with 33 kills. Eberle's aircraft had been marked with a double chevron but in accordance with temporary orders, this marking was painted over and the commander's aircraft was marked with a number. The JG 1 crest was painted on the left side of the cowling only. The rear part of the fuselage was partially overpainted with RLM 76 to tone it down.

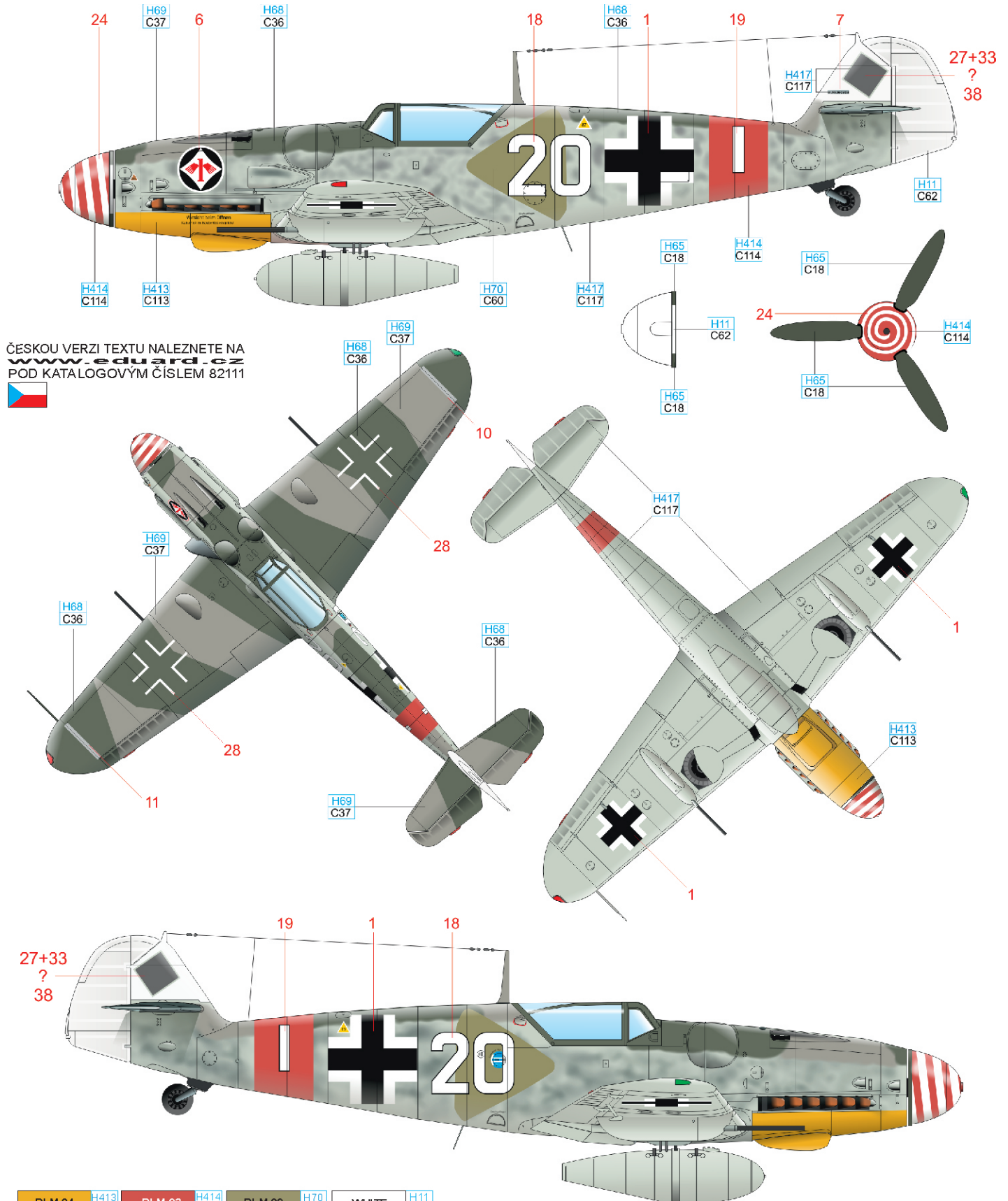

ČESKOU VERZI TEXTU NALEZNETE NA www.eduard.cz POD KATALOGOVÝM ČÍSLEM 82111



RLM 04	H413 C113	RLM 23	H414 C114	RLM 02	H70 C60	WHITE	H11 C62
RLM 74	H68 C36	RLM 75	H69 C37	RLM 76	H417 C117	RLM 70	H65 C18

B W.Nr. 15729, flown by Obstlt. Hermann Graf, Stab./JG11, Jever, early 1944

This aircraft was manufactured by the Erla factory as a Bf 109G-5 high-altitude fighter, but was converted to G-6 standard later. What was typical for the G-5 and retained during the conversion was the anti-fog capsule in the windscreens. The camouflage scheme is unusual – the former camouflage including the Stab marking was oversprayed with a light grey colour, probably RLM 76. Hermann Graf commanded JG 11 from November 11, 1943 till March 29, 1944 and despite the fact that he was officially banned from flying, he managed to down seven aircraft – amounting to the final kills of his career. He is credited with 212 victories in total (the majority of which were with JG 52 and three with JGr 50). He was awarded for his successes during the war as well as after. He received Diamonds to his Ritterkreuz with Oak Leaves and Swords, the fifth recipient of this honour, on September 29, 1942. Graf participated in propaganda campaigns, and he was a member of the Luftwaffe soccer team. At the end of the war, Graf led JG 52 and retreated from East Prussia via Silesia to Bohemia and surrendered to US forces at Pisek on May 8, 1945. He was promptly handed over to the Russians and spent more than four years in Russian captivity.

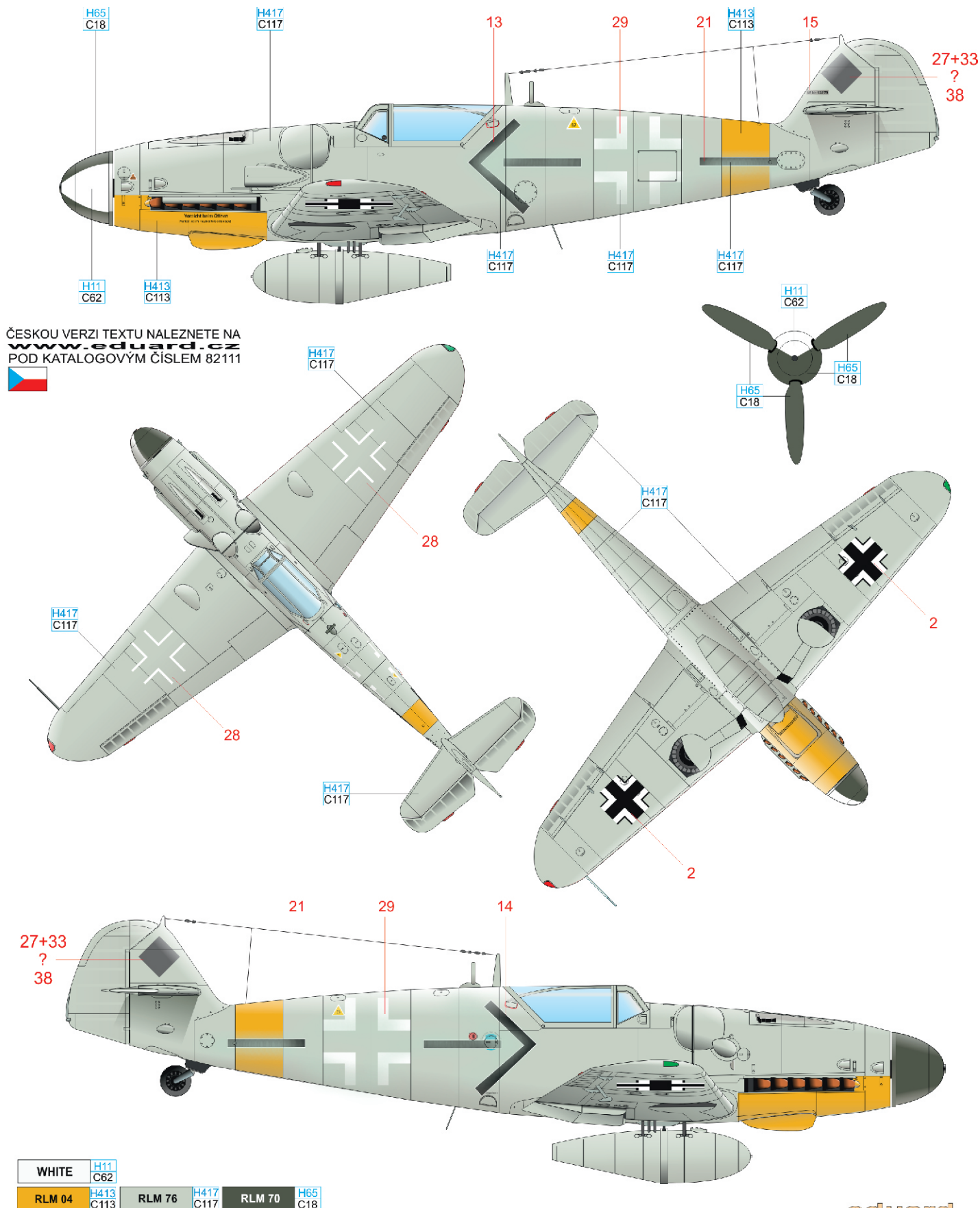

C W.Nr. 411960, flown by Hptm. Franz Dörr, the CO of III./JG 5, Gossen, Norway, May, 1945

Franz Dörr downed his first victim, a British Wellington bomber, on September 29, 1941 as a member of 1.(Erg.)/JG 3. This unit was redesignated 7./JG 5 on January 1, 1942. In early May 1944, Dörr took command of III. Gruppe of JG 5 and led this unit till the end of war. Dörr was awarded the Ritterkreuz on August 19, 1944. He managed to down 122 enemy aircraft – his score is marked on the rudder of his personal Bf 109G-6, W. Nr. 411960. This aircraft was manufactured at the Erla factory and sports all its typical characteristics such as the small bulge on the right side of the cowl and different gun troughs. The exact colour of the spinner is inconclusive from photographic evidence but can be black with a white spiral. The small disc on the rear fuselage identified III. Gruppe aircraft.

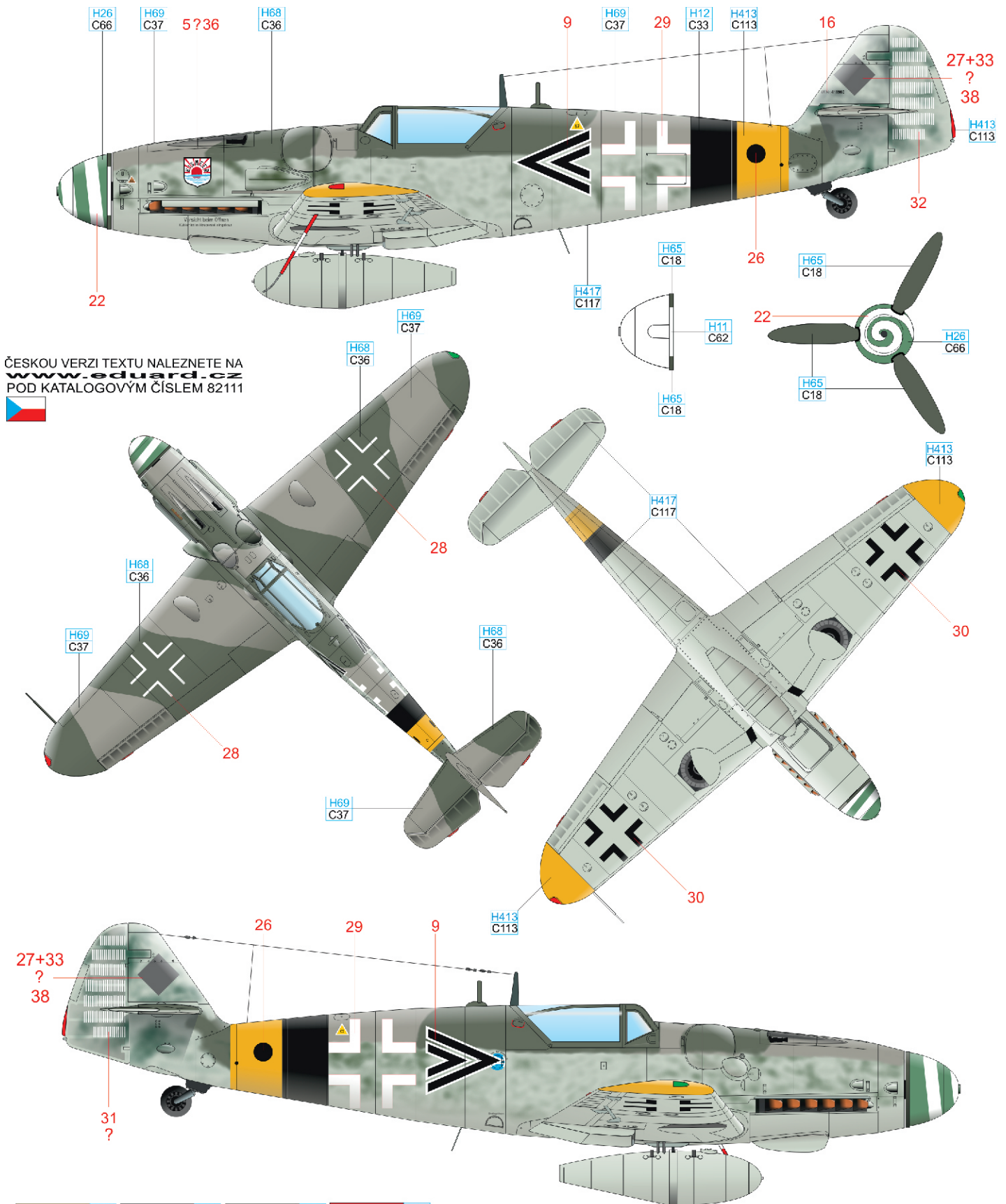

ČESKOU VERZI TEXTU NALEZNETE NA www.eduard.cz POD KATALOGOVÝM ČÍSLEM 82111



RLM 04	H413 C113	BLACK	H12 C33	RLM 25	H26 C66	RLM 23	H413 C113
RLM 74	H68 C36	RLM 75	H69 C37	RLM 76	H417 C117	RLM 70	H65 C18

E W.Nr. 165350, flown by Lt. Anton Hafner, the CO of 8./JG 51, Tilsit-Ost, August, 1944

Hafner was photographed in the cockpit of this particular aircraft in August, 1944, when his unit was based at an airfield close to Tilsit in East Prussia (today Sovetsk, a city on the Russian-Lithuanian border). Anton Hafner is credited with a total of 204 victories, all of them achieved as a JG 51 pilot. He served with JG 51 not only on the Eastern Front where he downed the majority of his opponents, but in North Africa as well, where he was shot down and injured. He met up with his destiny on October 14, 1944. During a dogfight with his 204th and final victim, a Yak-9, Hafner hit some trees and succumbed to his resulting injuries. He was awarded the Ritterkreuz on August 23, 1943 and Oak Leaves were added on April 11, 1944. The appearance of this aircraft was partially reconstructed from existing photos. It could have the standard rudder. The fuselage is darkened with blotches of RLM 74 and 75.

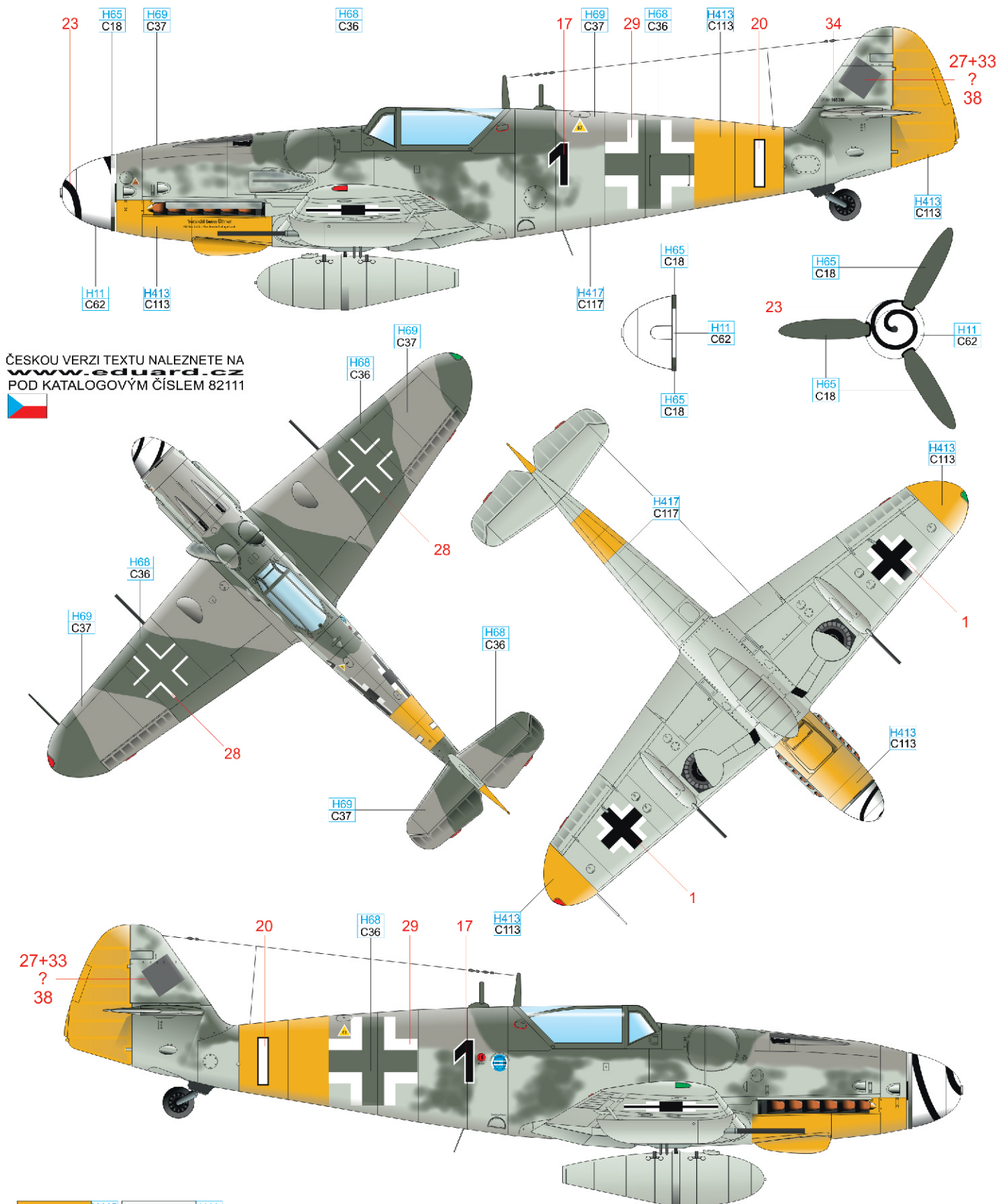

ČESKOU VERZI TEXTU NALEZNETE NA www.eduard.cz POD KATALOGOVÝM ČÍSLEM 82111



RLM 04	H413 C113	WHITE	H11 C62
RLM 74	H68 C36	RLM 75	H69 C37
	RLM 76	H417 C117	RLM 70
		H65 C18	

