

Bf 109G-2

eduard

GERMAN WWII FIGHTER

1/48 SCALE PLASTIC KIT

ProfiPACK
edition

#82116



INTRO

No other aircraft of the German Luftwaffe is so intimately connected with its rise and fall in the course of the Second World War than the Messerschmitt Bf 109. This type, by whose evolution outlined the era in which it was conceptualized, bore the brunt of Luftwaffe duties from the opening battles of Nazi Germany through to her final downfall. The history of the aircraft begins during 1934-35, when the Reich Ministry of Aviation formulated a requirement for the development of a single-engined monoplane fighter. Proposals were submitted by Arado, Heinkel, Focke-Wulf and Bayerische Flugzeugwerke. The last mentioned firm featured a technical director named Professor Willy Messerschmitt, who was riding a wave of popularity based on the success of his recent liaison aircraft, the Bf 108. His goal was to conceive of an aircraft with the best possible performance for the specified weight, size, and aerodynamic qualities. Over the subsequent months, several prototypes were built that served first and foremost in development flights and further modifications. The aircraft was relatively small, and compared to the prevailing trends of the time, docile with revolutionary features such as low wing design, the use of a retractable landing gear, a wing with a very narrow profile, wing slats, landing flaps, weapons firing through the prop hub, and so on. Even the enclosed cockpit and the method of construction were not very common just four years prior to the beginning of the Second World War. At its conception, the Bf 109 was a very promising asset despite some powerplant troubles. These were solved by the introduction of the DB 601. This engine, together with its extrapolated development DB 605, is umbilically connected to the types success. These two-row, twelve cylinder inverted V engines powered several tens of thousands of '109s in over 25 versions and variants.

The first combat use was by three developmental Bf 109s in the Spanish Civil War, where they were delivered in December 1936. The pre-series airframes were to, first of all, validate the aircraft's abilities in modern aerial combat. Shortly thereafter, production machines in the form of the Bf 109B-1 began to reach 2./J.88, the Legion Condor. The desire of Germany to demonstrate her aerial prowess to potential foes was advanced further in international sport meets. The triumphs attained in Zurich in the summer of 1937 were complemented several months later by grabbing the speed record of 610.95 kph. In very short order, the progressive developments represented by the C, D and E versions appeared. Despite this, the delivery of the types to combat units did not sustain a rate that was desired by military brass. Even by August 1938, the Bf 109 accounted for less than half of the 643 front line fighters in service. The later months saw an increase in these rates. By the time of the invasion of Poland (which saw the participation of only a little more than 200 aircraft) the Luftwaffe possessed the best fighter produced in continental Europe. With both a qualitative and quantitative advantage, the fighter wing of the Luftwaffe entered the Polish campaign, the first defenses of the Fatherland, Blitzkrieg against the West, and the Battle for France. With one foot in the door that was the English Channel, the Luftwaffe embarked on the attacks on Britain in the summer months of 1940. Here, the first weakness of the Bf 109 was revealed: the inability to carry drop tanks that would have enabled the type to effectively escort bombers to England. This was one of the factors that made the defeat of the Luftwaffe in the Battle of Britain possible. Experiences gained in 1940 led to the development of the 'F' version prior to the spring of 1941. The elegance of the Bf 109 crested with the 'Friedrich'. Following a largely defensive stance over the Channel and northern France, the Bf 109F took on a more offensive role in Operation Barbarossa in the east, and in northern Africa. In later duties with the 'Jagdwaaffe' during the second phase of the war in the east, and in the 'Defense of the Reich' from 1943 to 1945, the Bf 109 served in the form of the 'G' version, followed by the 'K'. Even if by the end of the war it was clear that the development of the Bf 109 was exhausted, during its combat career, the type was able to keep pace with the foes that it encountered. Besides its primary function as fighter, the Bf 109 also appeared as a fighter-bomber, reconnaissance platform, night fighter, trainer and Rammjäger.

The disappearance of the Bf 109 from the skies over Europe was not spelled out by the end of the war. Several examples were in Swiss service up to 1949, and many flew in the air force of Czechoslovakia in both original form with a DB 605 powerplant and as aircraft built out of necessity with surplus Jumo 211s. The latter type also served as the first fighter to fight for the independence of the newly formed state of Israel. Finland retired the type as recently as 1954, and Spain didn't retire its HA-1109-1112, re-engined Bf 109s, until 1967. The legendary low-wing fighter of Professor Willy Messerschmitt survived the state that developed it.

ÚVODEM

Žádný jiný stroj německé Luftwaffe není výrazněji spojen s jejím vzestupem a pádem ve 2. světové válce, než stíhací Messerschmitt Bf 109. Letoun, který svou koncepcí výrazně předběhl dobu, ve které vznikl, se stal tahounem stíhacího letectva od prvních válečných konfliktů nacistického Německa, až do jeho hořkého konce. Historie letounu se začíná v období let 1934-35, kdy Říšské ministerstvo letectví formulovalo specifikace zakázky na vývoj jednomotorové jednoplošné stíhačky. Projektu se zúčastnily firmy Arado, Heinkel, Focke-Wulf a Bayerische Flugzeugwerke. V poslední jmenované působil na postu technického ředitele profesor Willy Messerschmitt, jehož popularita se nesla na vlně úspěchu nedávno dokončeného kurýrního Bf 108. Jeho cílem bylo vytvořit letoun s co největším poměrem výkonu k celkové hmotnosti, velikosti a aerodynamickým vlastnostem. V průběhu následujících měsíců vzniklo několik prototypů, které sloužily zejména ke zkouškám a dalšímu vývoji. Letoun byl poměrně malý, oproti stávajícím zvyklým relativně jemný, s revolučními konstrukčními prvky jako byla dolnokřídla koncepce, použití zatahovacího podvozku, křídlo s velmi štíhlým profilem, pohyblivé sloty, vztlakové klapky, zbraně střelící osou vrtule, atd. Dokonce uzavíratelný překryt kabiny nebo skořepinová konstrukce nebyly čtyři roky před začátkem 2. světové války tak obvyklým jevem, jak by se z dnešního pohledu mohlo zdát. Bf 109 byl již od počátku svého vývoje, i přes problémy s pohonnou jednotkou, velmi nadějným projektem. Problémy s pohonem vyřešila až zástavba motoru DB 601. Ten je spolu s pozdějším DB 605 neodmyslitelné spojení s úspěšným Bf 109. Řadový invertní dvanáctiválec do V poháněl několik desítek tisíc vyrobených „stodevíték“ ve více než 25 verzích a variantách.

K prvnímu bojovému nasazení tři zkušební kusy Bf 109 došlo za občanské války ve Španělsku, kam byly odeslány v prosinci 1936. Stroje z předseriesové výroby měly především ukázat schopnosti letounu v moderní letecké válce. Následně se do bojového nasazení v 2./J.88 Legion Condor začaly dostávat i sériové stroje varianty Bf 109B-1. Snaze Německa ukazovat svou leteckou sílu potenciálním protivníkem napomáhala i sportovní klání. Triumf letounů Bf 109 na leteckém mítinku v Curychu v létě 1937 byl doplněn o několik měsíců později ustanovením rychlostního rekordu 610,95 km/h. Ve velmi krátkých časových úsecích následovaly verze C, D a E. Přesto však doplňování nových strojů k bojovým útvarům nepokračovalo tempem, který by si velení mohlo přát. Ještě v srpnu roku 1938 tvořila výzbroj letouny Bf 109 méně než polovinu z 643 stíhaček první linie. Ovšem během následujících měsíců roku se tempo dodávek k bojovým útvarům zrychlilo. V okamžik předání Polska (kterého se však zúčastnilo jen o málo více než dvě stě Bf 109) tak Luftwaffe disponovala jistě nejlepší stíhačkou, jaká byla v kontinentální Evropě vyrobena. S technickou i množství převahou tak stíhací část Luftwaffe absolvovala polskou kampaň, první obranu Váterlandu, Blitzkrieg proti západu i bitvu o Francii. S jednou nohou vykročenou přes kanál La Manche zahájila Luftwaffe v letních měsících roku 1940 útoky na Británii. V tu dobu se mj. projevil jeden vážný nedostatek Bf 109 - nepřipravenost konstrukce stroje na nesení přídavné nádrže, která by zvýšila dolet letounu při doprovodu bombardérů nad Británii. Tato zdanlivá maličkost byla jedním z faktorů, které zapříčinily porážku Luftwaffe v Bitvě o Británii. Zkušenosti z bojů v r. 1940 napomohly při vývoji verze F, která se začala k bojovým útvarům dostávat během předjaří 1941. Elegance Bf 109 u „Friedricha“ dosáhla vrcholu. Po bojích nad Kanálem a severní Francií, spíše již defenzivního charakteru, se Bf 109F zapojily i do útočných akcí, a to zejména při operaci Barbarossa na východě nebo v severní Africe. Do pozdějších úkolů Jagdwaaffe ve druhé fázi války na východě i do obrany Říše v letech 1943 - 1945 se zapojovaly především Bf 109 verze G a v posledních měsících války pak také verze K. Ačkoli na konci války bylo jasné, že koncepce letounu Bf 109 se po deseti letech služby dostala na hranici možností, po celou dobu své bojové činnosti dokázaly jednotlivé varianty držet krok se svými stíhacími protivníky. Kromě svého prioritního určení stíhacího letounu se Bf 109 objevily i v rolích stíhací-bombardovací, průzkumná, noční stíhací, palubní stíhací, cvičné nebo jako Rammjäger.

Nebe se pro Bf 109 nezavřelo ani po skončení války. Několik strojů sloužilo až do roku 1949 ve Švýcarsku, mnohé létaly v balkánských zemích, v osvobozeném Československu, a to jak v původní podobě s motory DB 605, tak v přestavěné variantě s motory Jumo 211. Zejména tyto stroje později tvořily základ letectva bráničného svobody nově budovaného státu Izrael. Finsko zrušilo Bf 109 až v roce 1954 a Španělsko opustilo své HA-1109 a 1112 dokonce až v roce 1967.

ATTENTION



UPOZORNĚNÍ



ACHTUNG



ATTENTION



注意



Carefully read instruction sheet before assembling. When you use glue or paint, do not use near open flame and use in well ventilated room. Keep out of reach of small children. Children must not be allowed to suck any part, or pull vinyl bag over the head.



Před započítím stavby si pečlivě prostudujte stavební návod. Při používání barev a lepidla pracujte v dobře větrané místnosti. Lepidla ani barvy nepoužívejte v blízkosti otevřeného ohně. Model není určen malým dětem, mohlo by dojít k požití drobných dílů.

INSTRUCTION SIGNS * INSTR. SYMBOLS * INSTRUKTION SINNBILDEN * SYMBOLES * 記号の説明

OPTIONAL
VOLBABEND
OHNOUTOPEN HOLE
VYVRTAT OTVORSYMMETRICAL ASSEMBLY
SYMETRICKÁ MONTÁŽREMOVE
ODŘÍZNOUTREVERSE SIDE
OTOČITAPPLY EDUARD MASK
AND PAINT
POUŽÍT EDUARD MASK
NABARVIT

PARTS



DÍLY



TEILE



PIÈCES



部品

PLASTIC PARTS

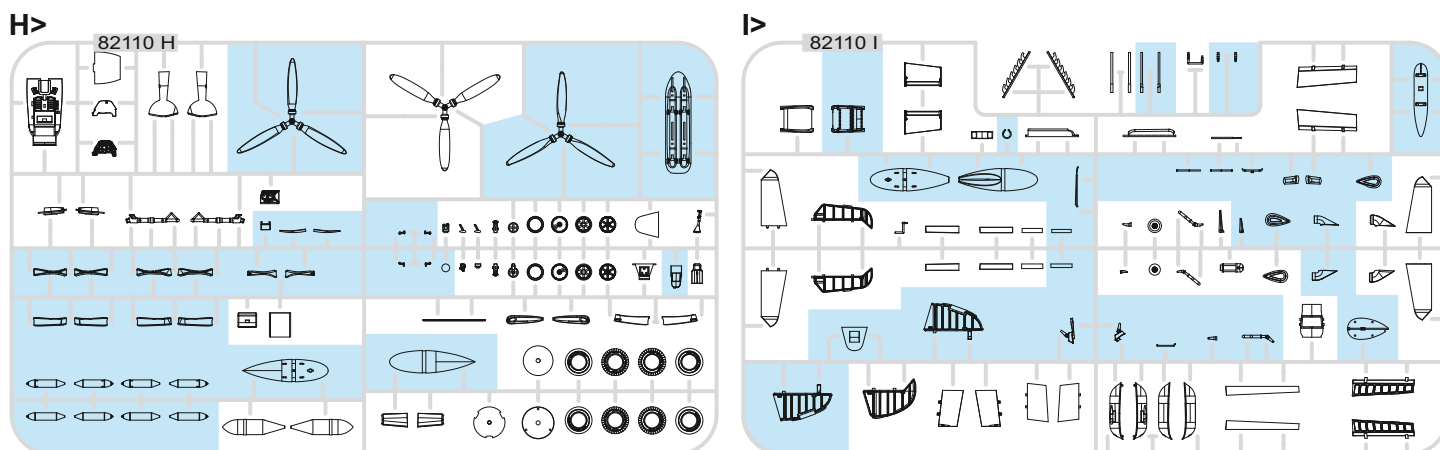

M>

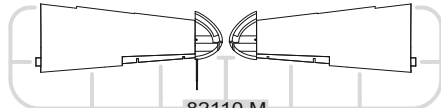

82110 M

K>

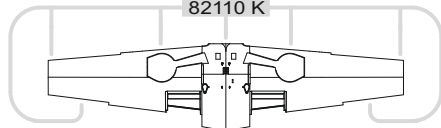

82110 K

N>

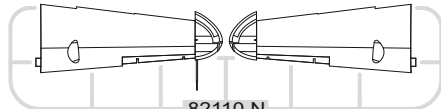

82110 N

S>

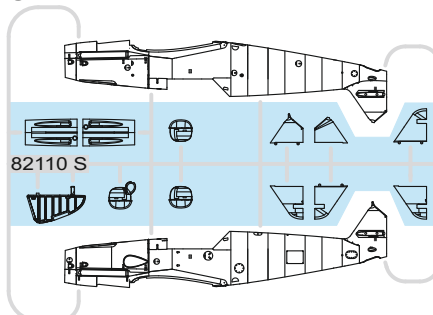

82110 S

J>

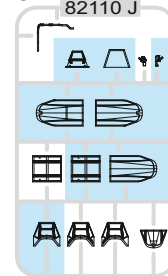

82110 J

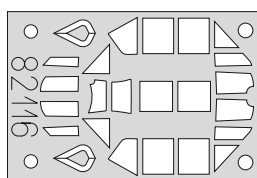
eduard
MASK

PE - PHOTO ETCHED DETAIL PARTS

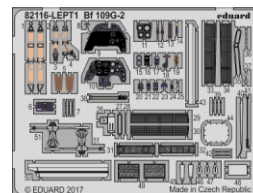

-Parts not for use. -Teile werden nicht verwendet. -Pièces à ne pas utiliser. -Tyto díly nepoužívejte při stavbě. - 使用しない部品

COLOURS



BARVY



FARBEN



PEINTURE



色

GSI Creos (GUNZE)			
AQUEOUS	Mr.COLOR		
H 2	C2	BLACK	
H 8	C8	SILVER	
H 11	C62	WHITE	
H 12	C33	FLAT BLACK	
H 25	C34	SKY BLUE	
H 47	C41	RED BROWN	
H 64	C17	DARK GREEN	RLM71
H 65	C18	BLACK GREEN	RLM70
H 66	C119	SANDY BROWN	RLM79
H 68	C36	DARK GRAY	RLM74
H 69	C37	GRAY	RLM75
H 70	C60	GRAY	RLM02

AQUEOUS	Mr.COLOR		
H 77	C137	TIRE BLACK	
H 90	C47	CLEAR RED	
H 94	C138	CLEAR GREEN	
H 413	C113	YELLOW	RLM04
H 414	C114	RED	RLM23
H 416	C116	BLACK GRAY	RLM66
H 417	C117	LIGHT BLUE	RLM76
H 418	C118	LIGHT BLUE	RLM78
H 420	C120	OLIVE GREEN	RLM80
Mr.METAL COLOR			
MC213		STAINLESS	
MC214		DARK IRON	

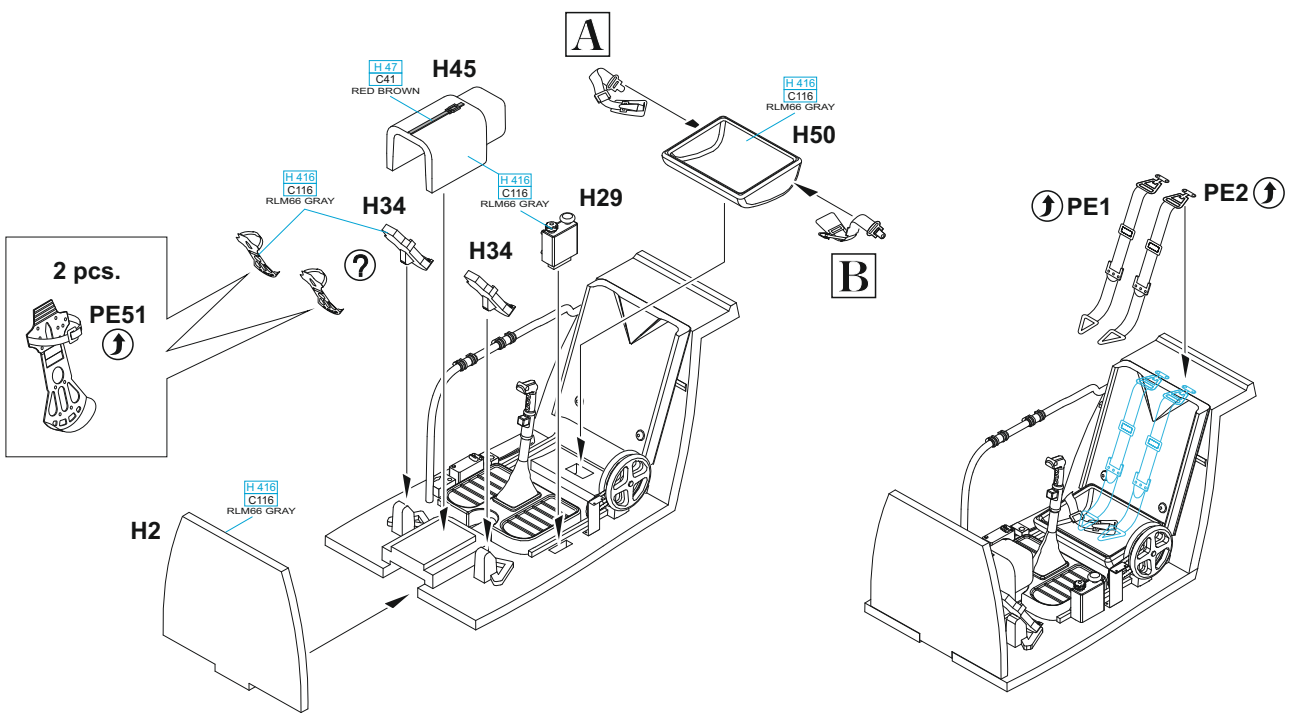
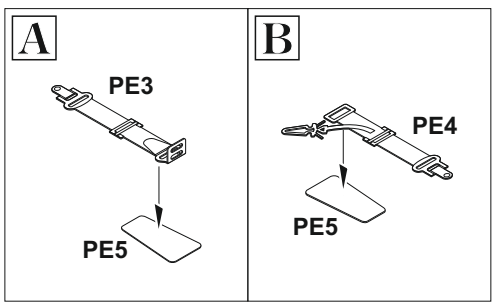
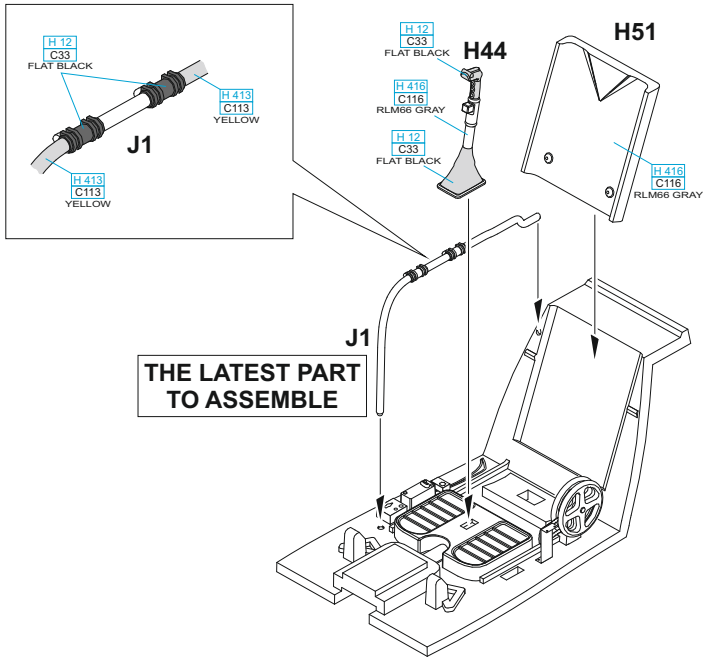
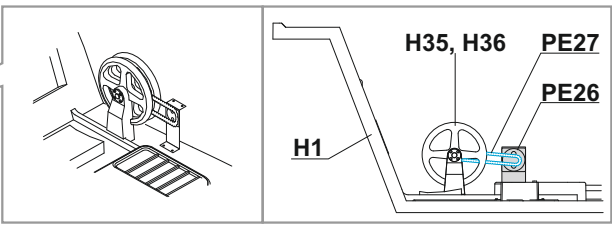
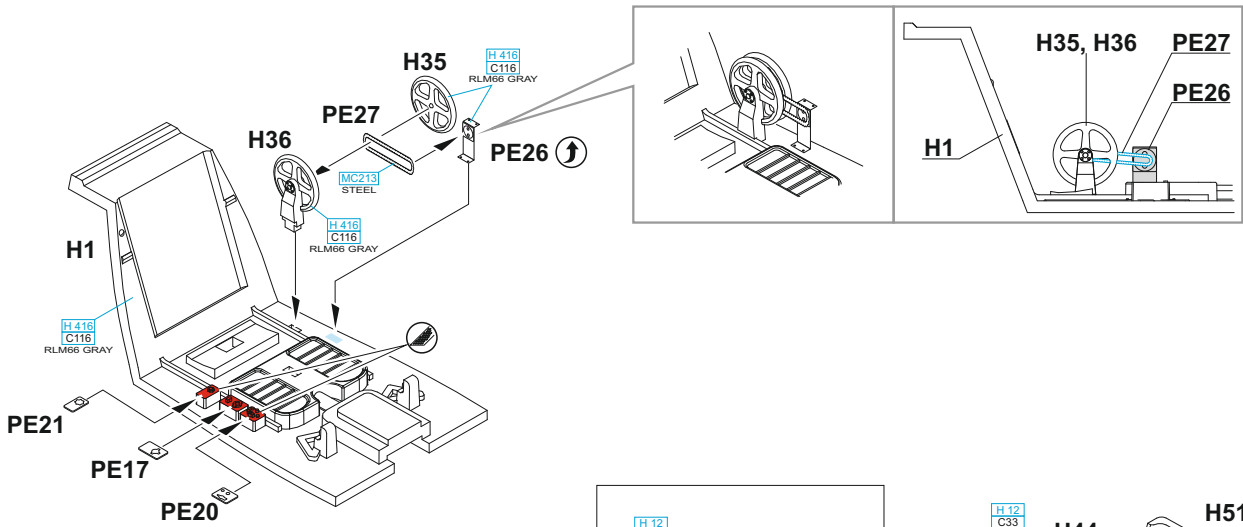

MARKING A ONLY

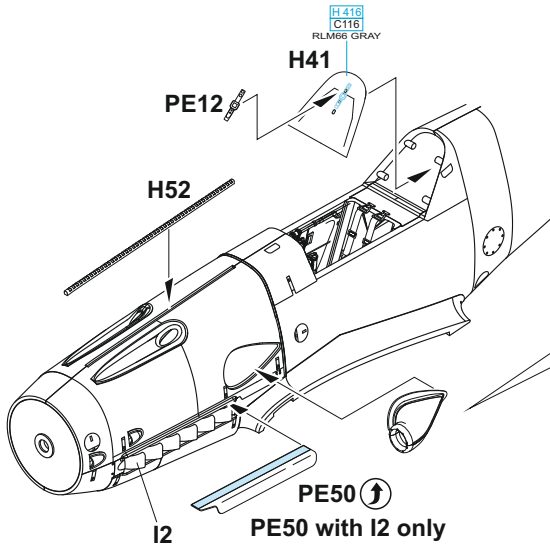

↑ PE49

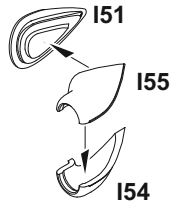
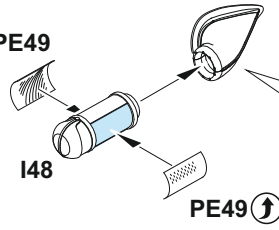

MARKING A ONLY

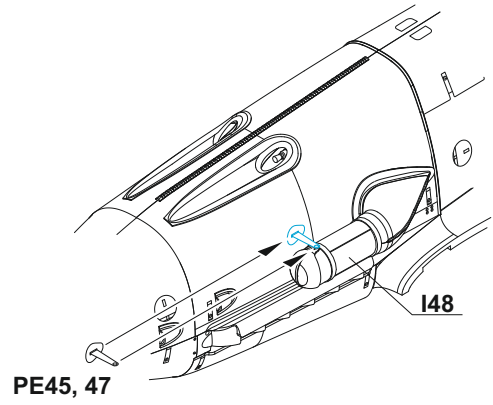

PE46, 47

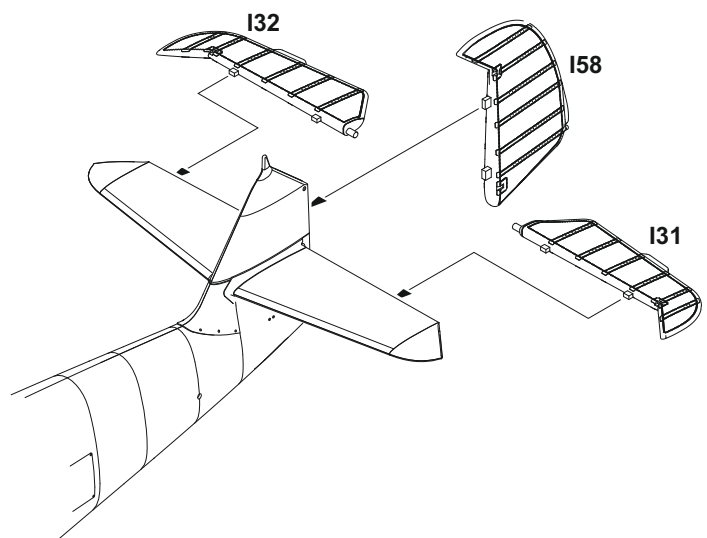
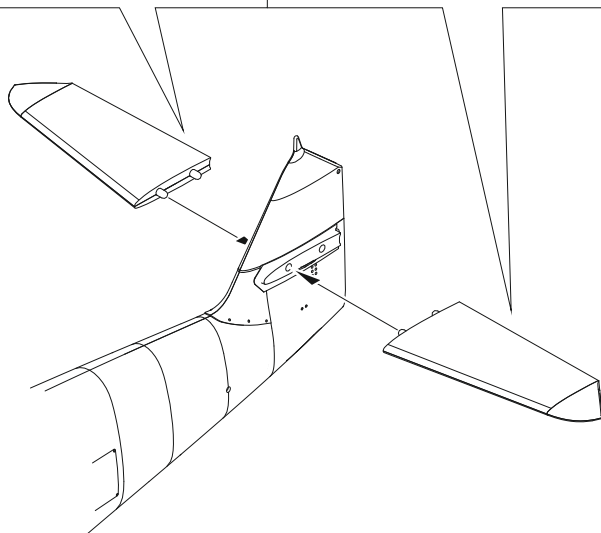
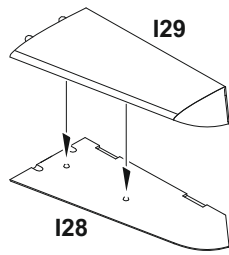
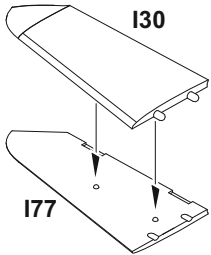
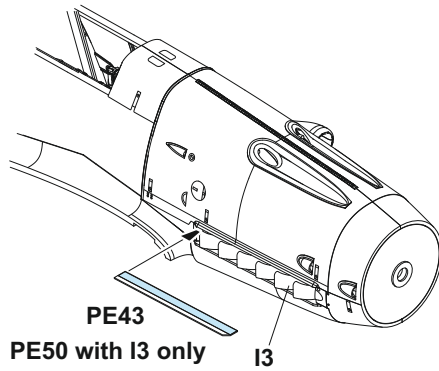
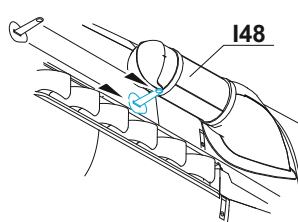

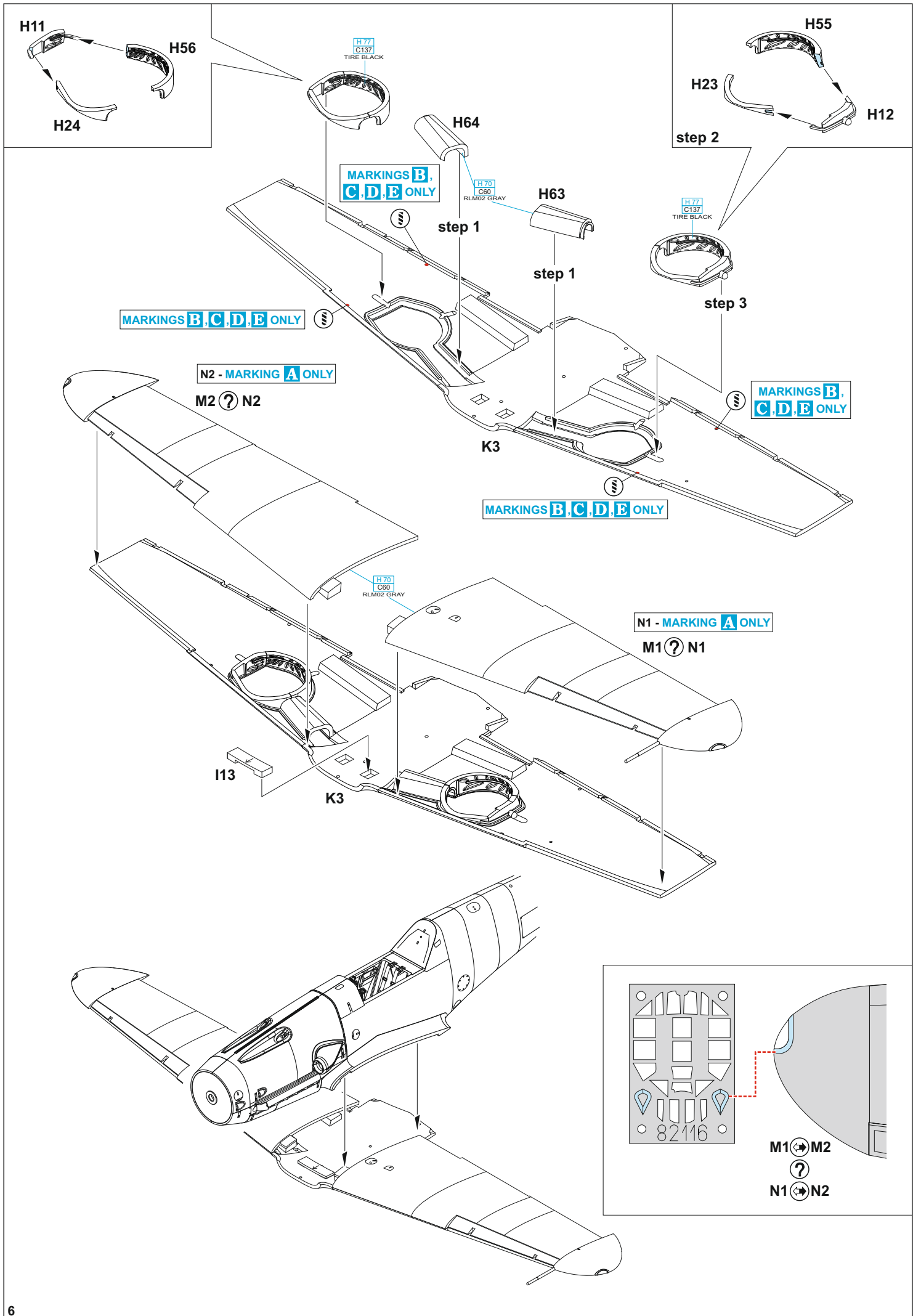

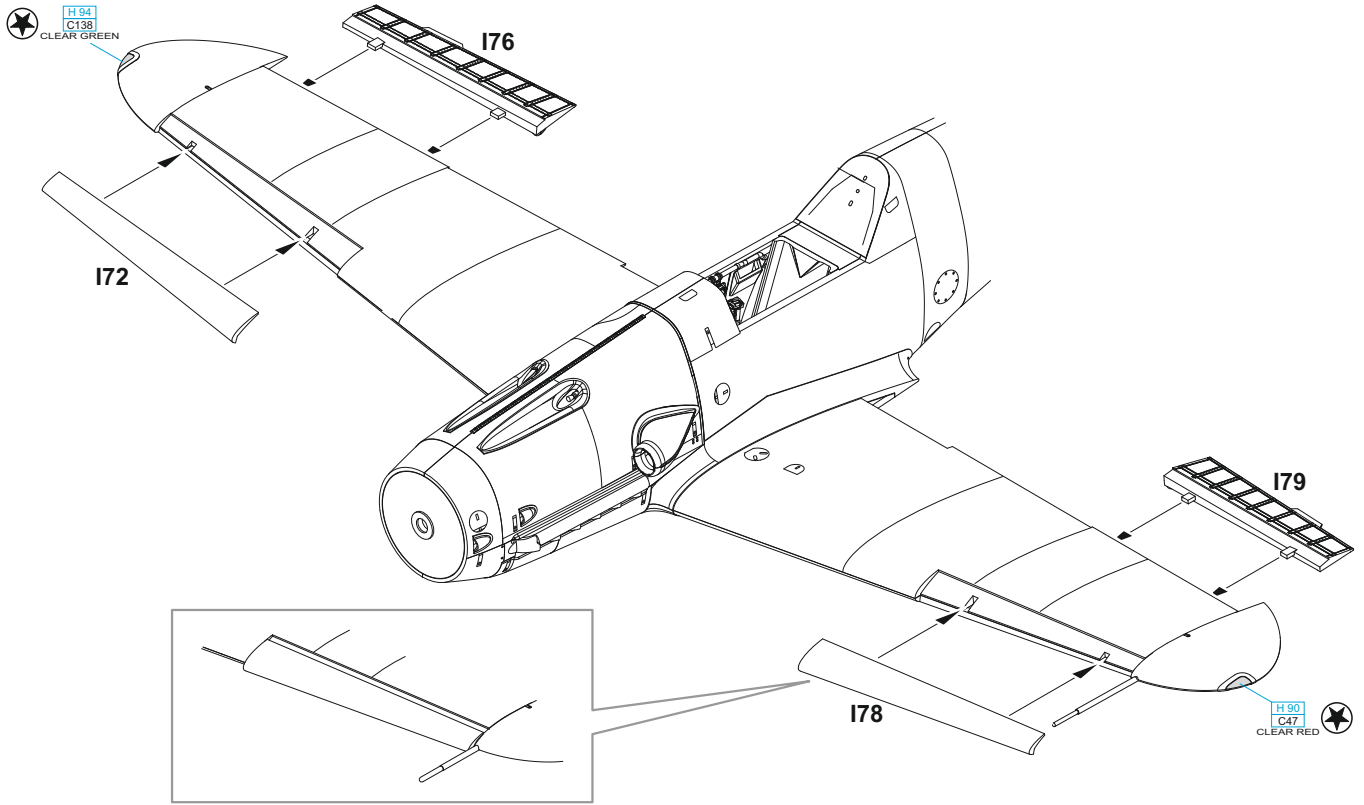

FRONT VIEW

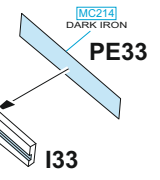
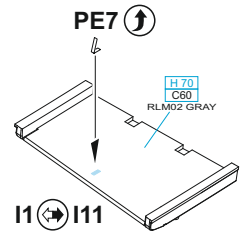
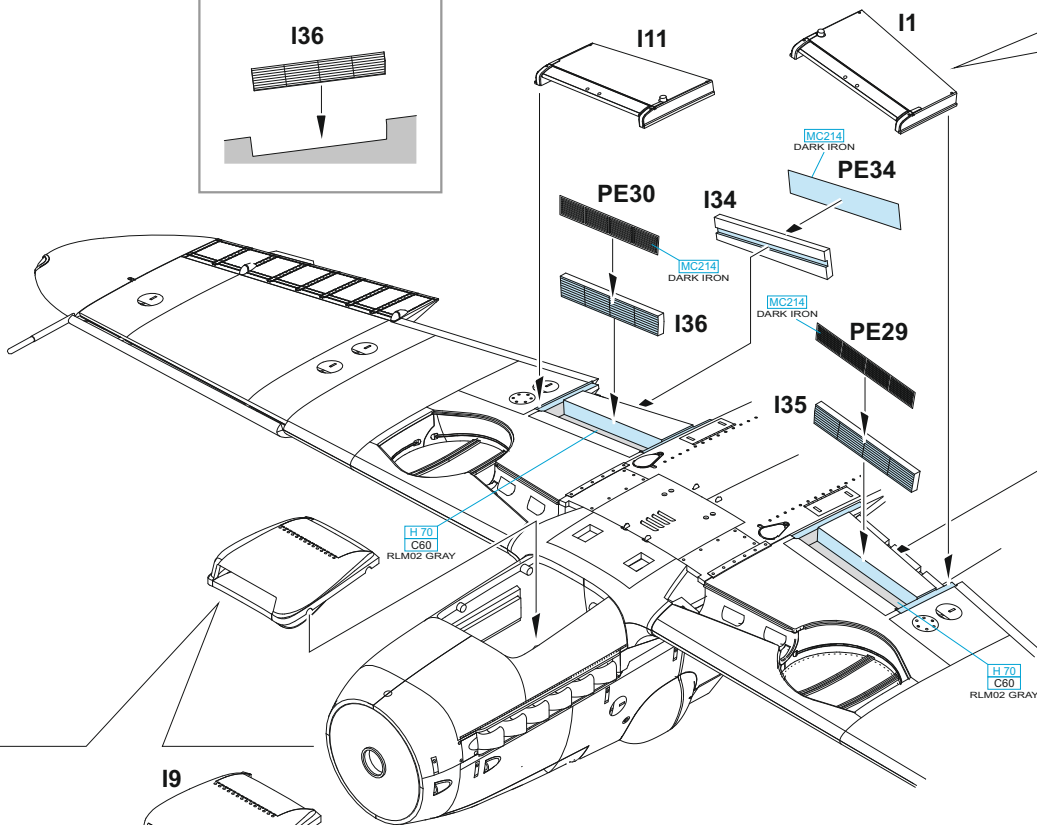
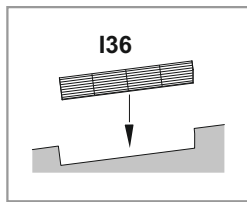

FRONT VIEW

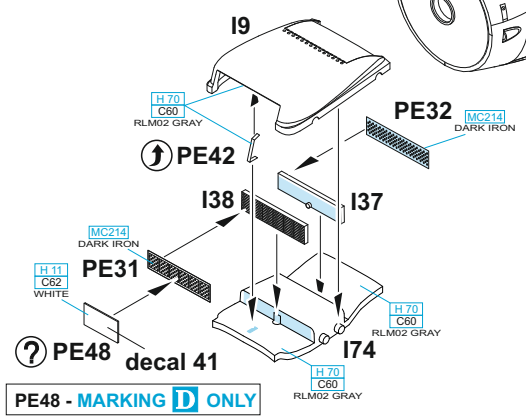
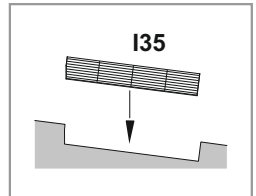

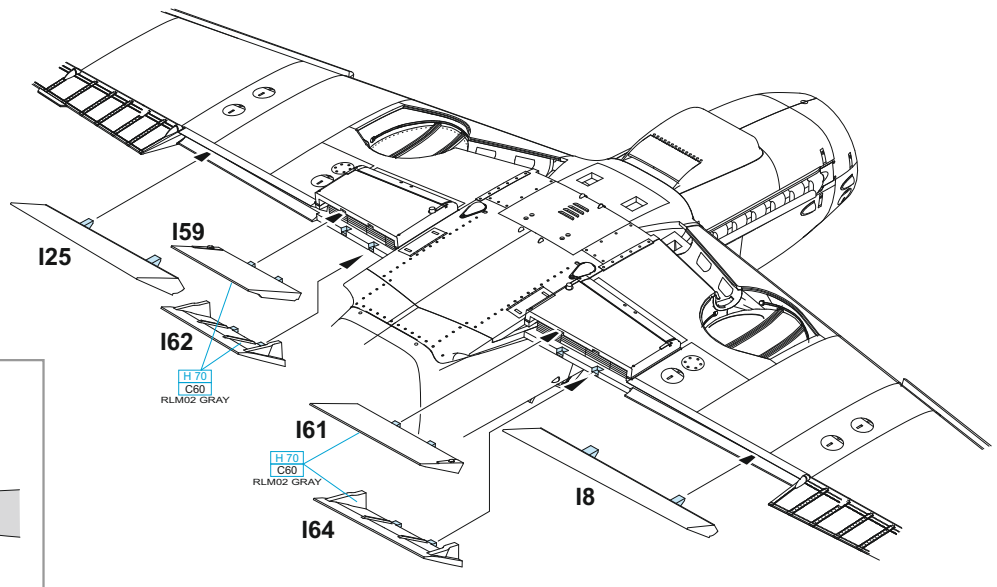

CORRECT POSITION OF RADIATOR FLAPS

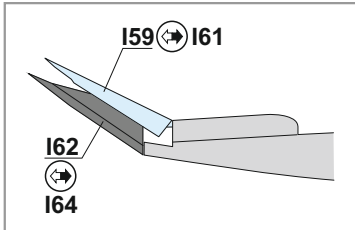

H37, H38, H71 ? H72 - MARKING A ONLY

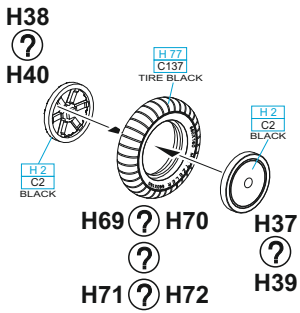

MARKING D ONLY

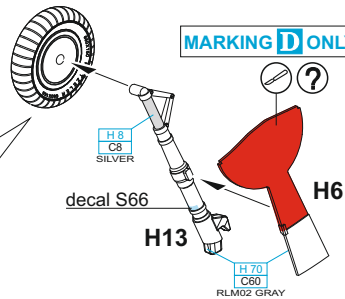

MARKING D ONLY

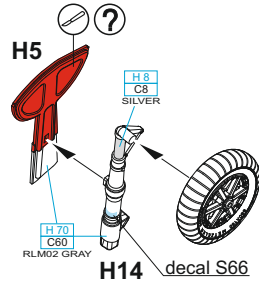

H37, H38, H71 ? H72 - MARKING A ONLY

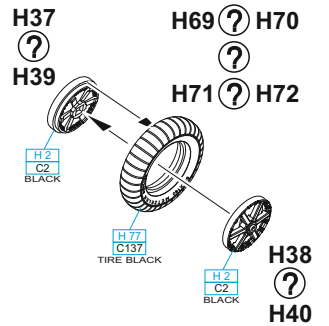

H36, H69 ? H70

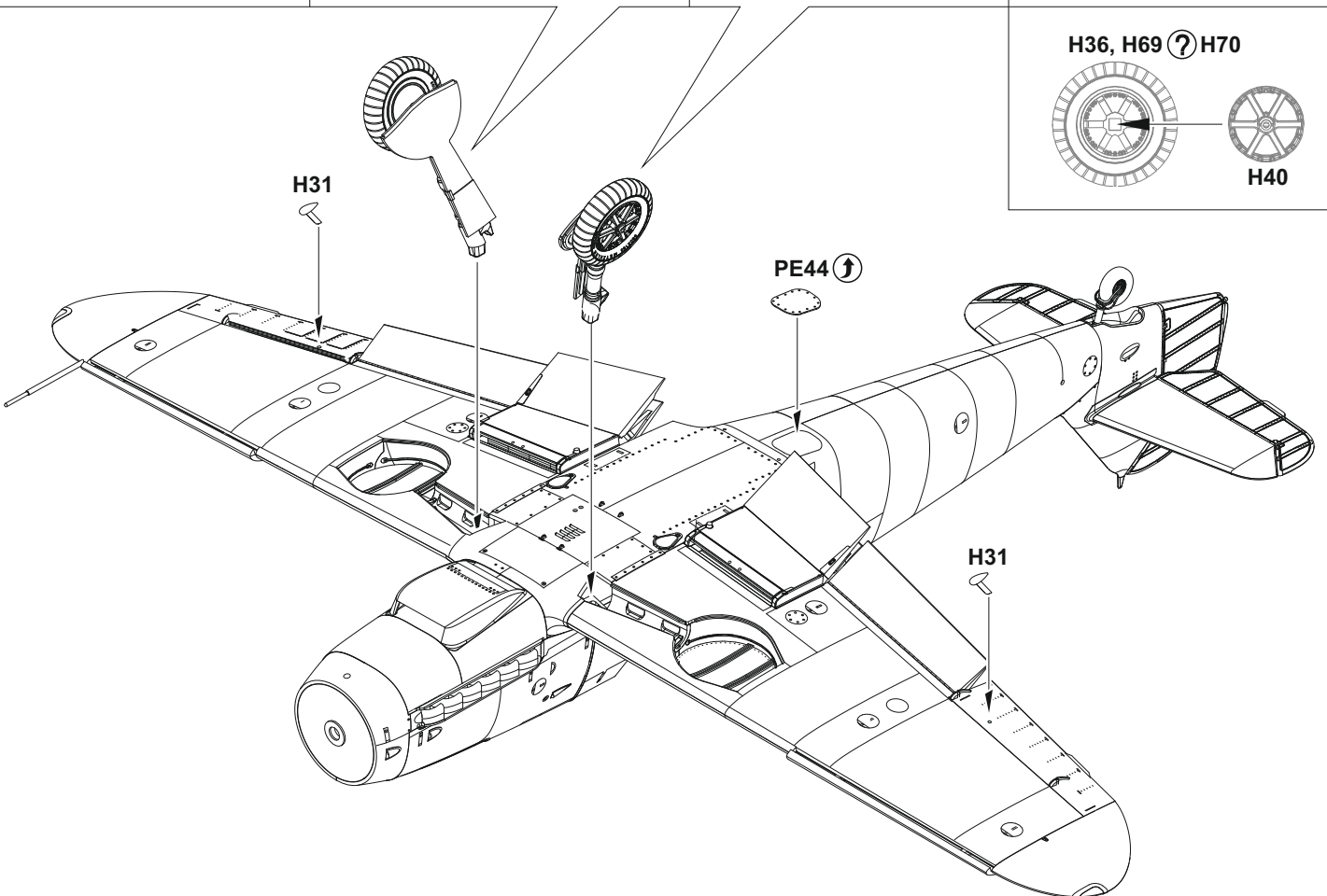
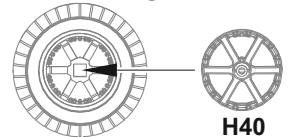

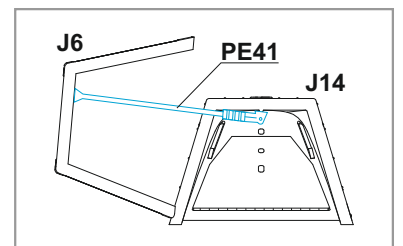
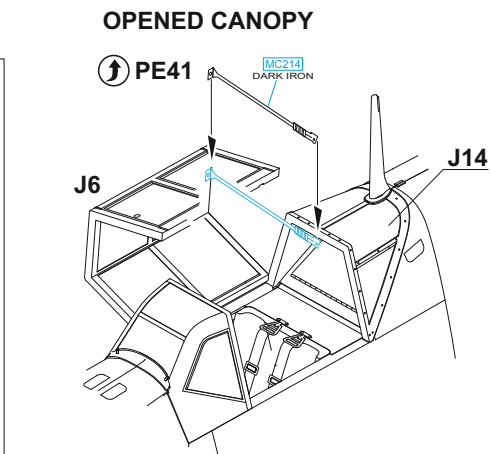
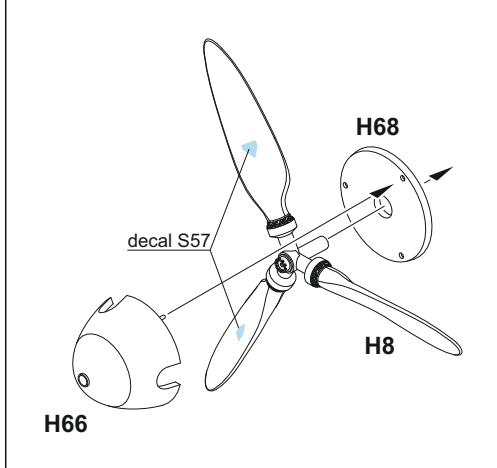
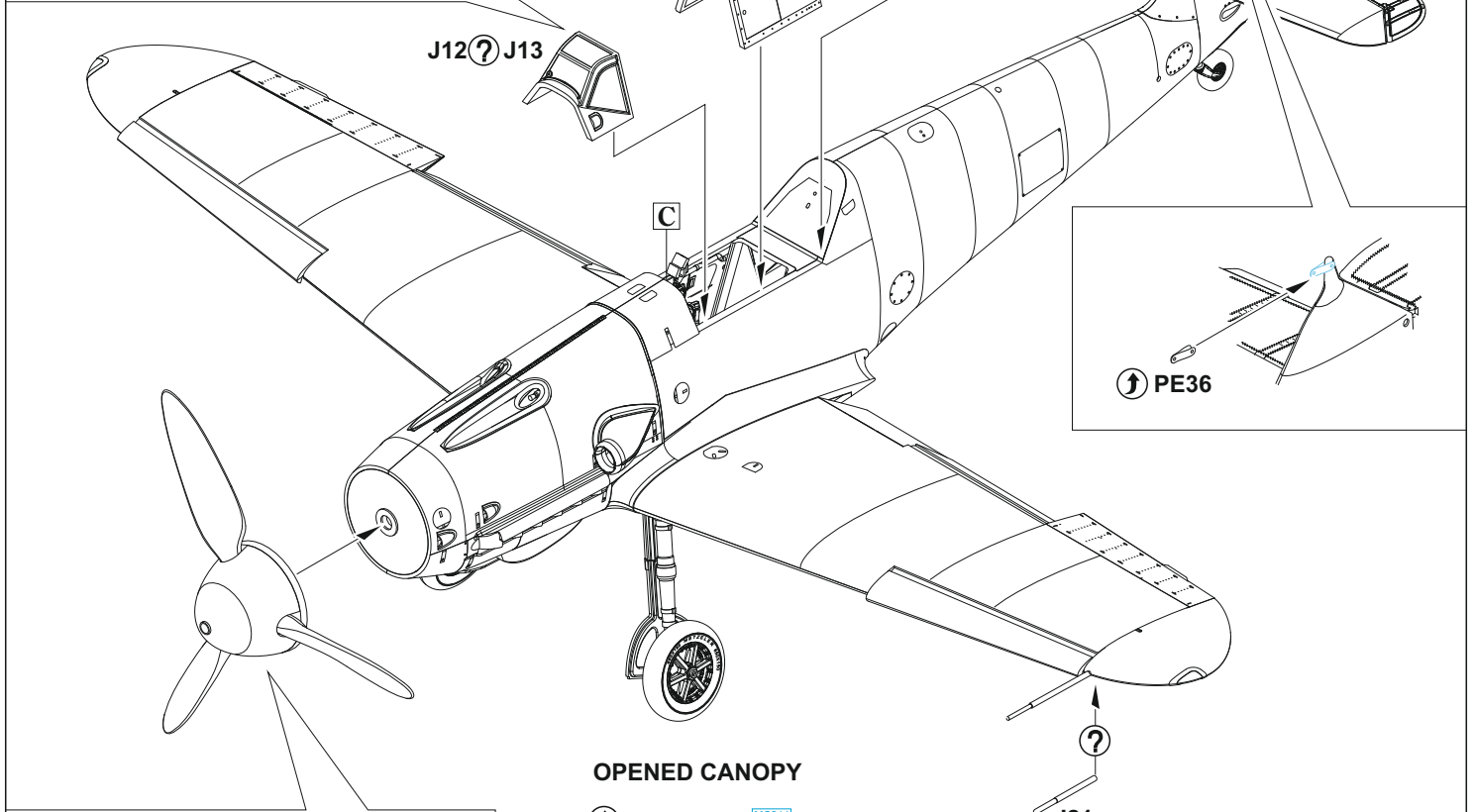
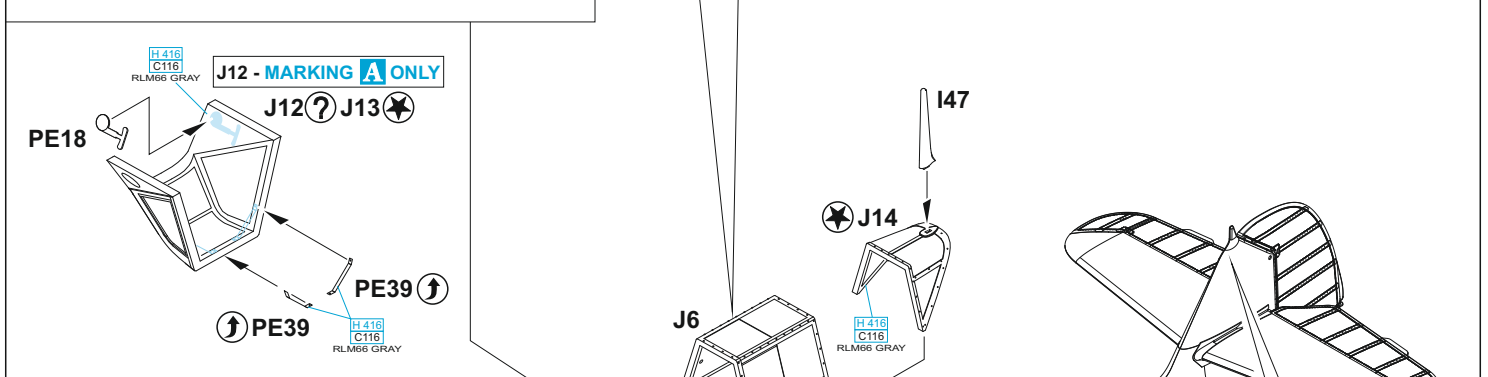
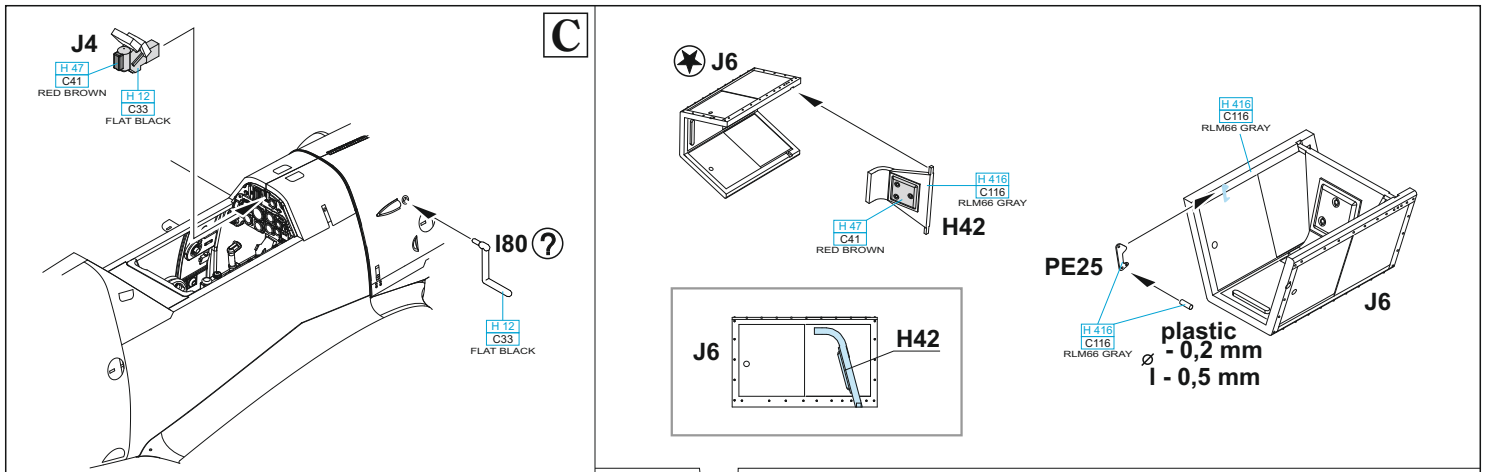

MARKINGS B, C, D, E ONLY

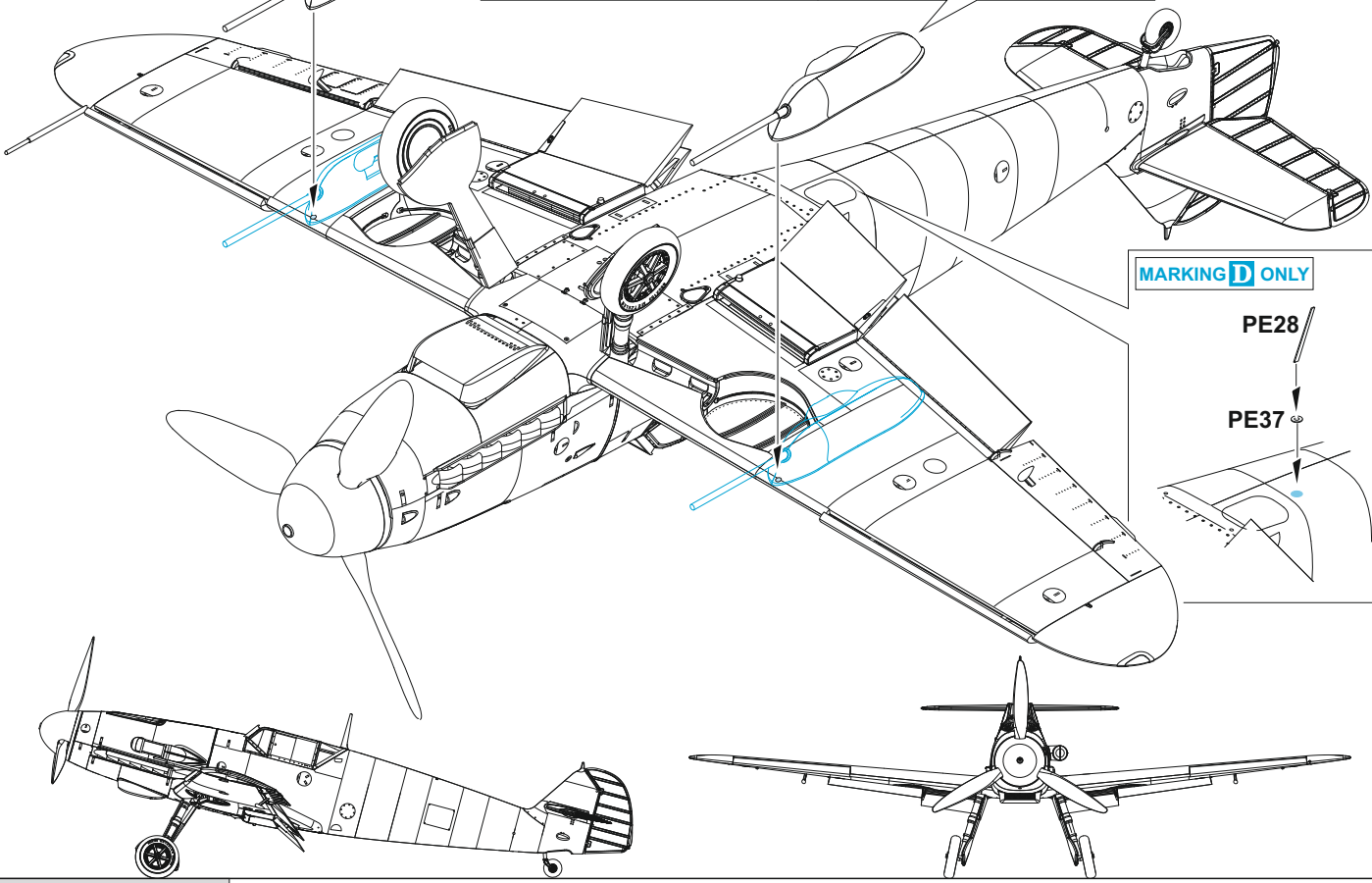
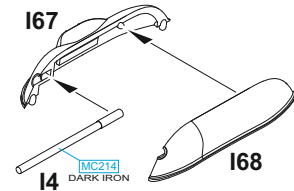
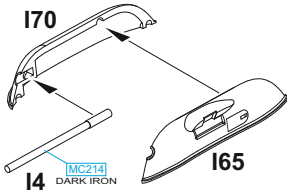

MARKING D ONLY

PE28

PE37

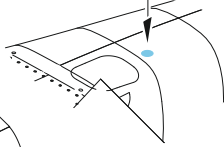

eduard
MASK
82116

inner side

inner side

outer side

outer side

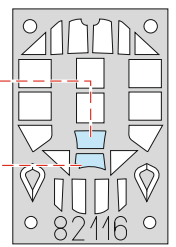
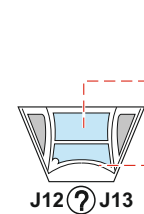
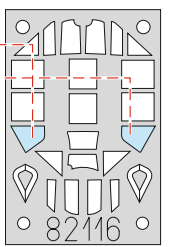
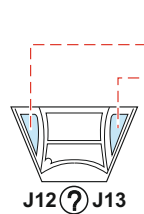
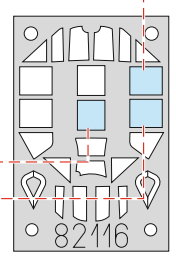
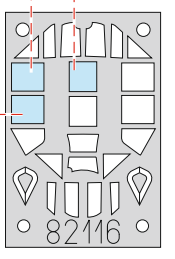
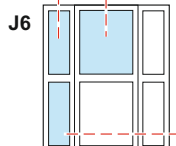
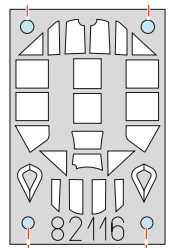
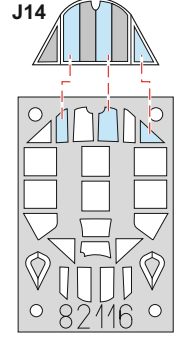
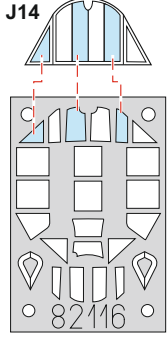
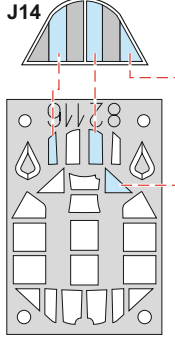
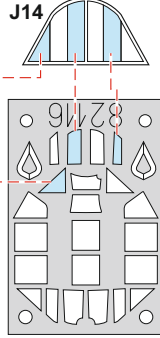

A Bf 109G-2/trop, 2./JG 77, Matmata, Tunisia, early 1943

After modified Messerschmitt Bf 109F-4 fighters, Luftwaffe fighter units also began to take delivery of the improved G-2/trop versions that were used by, among others, units of I. Gruppe Jagdgeschwader 77. This Bf 109G-2/trop from 2./JG 77 originally wore a standard camouflage scheme optimized for north Africa. The upper surfaces were sprayed RLM 79, and the lower surfaces RLM 78. Apparently as the result of a mishap, the G-2 wings were replaced by units intended for the G-4 with fairings over the wheel wells. Alternatively, this could be an example from the end of the G-2 production run when G-4 wings were installed. Subsequently, a squiggle pattern of RLM 80 was applied over the upper and side surfaces. The aircraft is also adorned with the identifiers for this area of operations, white wing tips and a white fuselage band. Ahead of the tail surfaces, the unit marking of a black tophat in a white circle was applied.

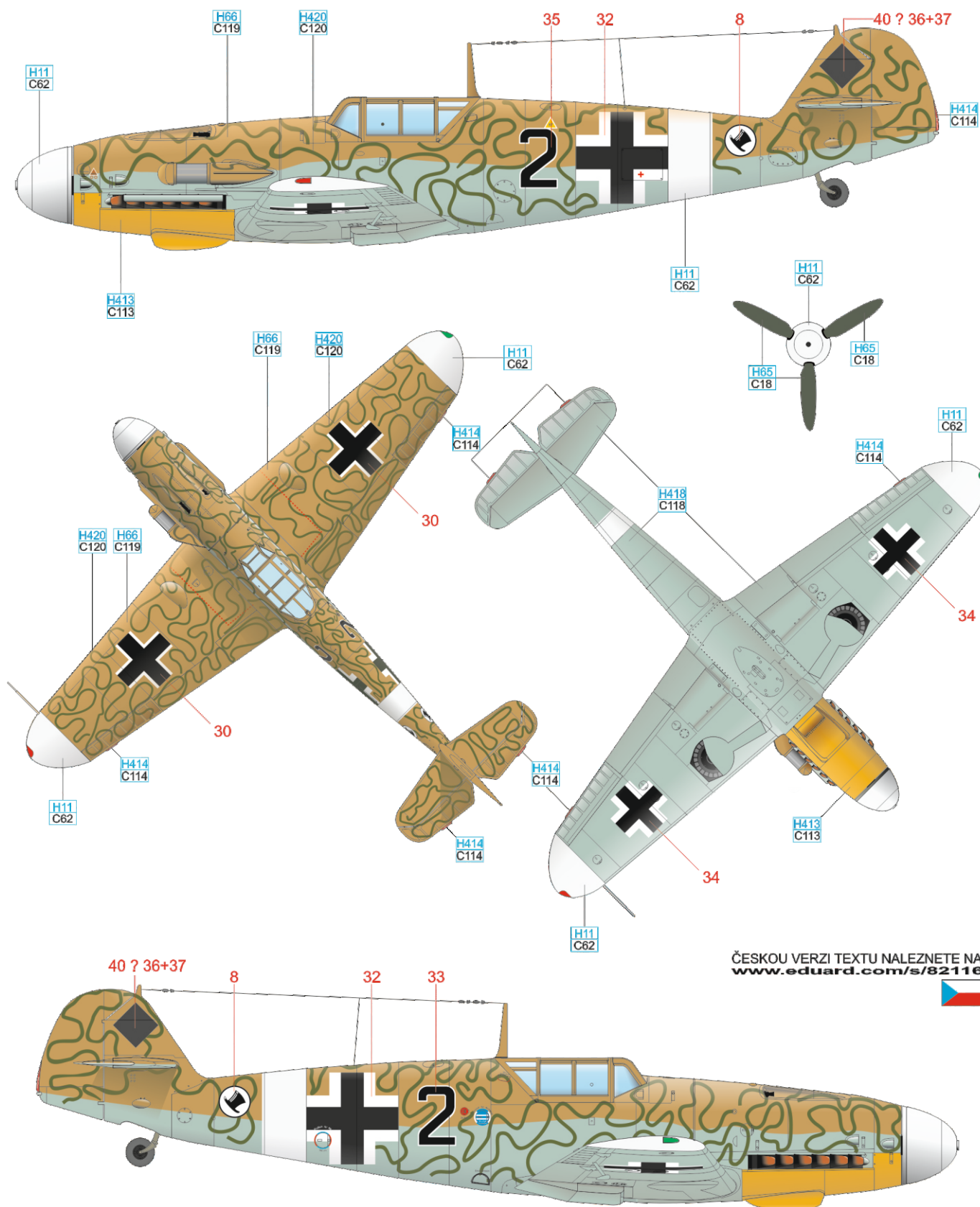

ČESKOU VERZI TEXTU NALEZNETE NA
www.eduard.com/s/82116



WHITE	H11 C62	RLM 23	H414 C114	RLM 70	H65 C18
RLM 04	H413 C113	RLM 78	H418 C118	RLM 79	H66 C119
				RLM 80	H420 C120

B Bf 109G-2/R-6/trop, W. Nr. 13916, Fw. Hans Döbrich, 6./ JG 5, Alakurtti, Finland, February 1943

Hans Döbrich gained 65 kills over his combat career and for his success he was awarded the Knight's Cross. On the other hand, he was himself shot down three times, with the final one resulting in serious enough injuries that he never returned to operational flying. He began using this aircraft on February 9th, 1943, when with 43 kills he was one of II./JG 5's most successful pilots. He involuntarily took to his parachute on March 14th, 1943, shortly after a scramble take-off from Salmijarvi due to engine failure. The original camouflage scheme composed of RLM 74/75/76 was filled in with white squiggles to make the aircraft less visible in winter conditions. The yellow identifying markings were used on aircraft on the Eastern Front. Döbrich's personal marking appears under the cockpit – a rendition of Mickey Mouse standing over II./JG 5's emblem ripping apart a Soviet I-16. The green four-leaf clover on the nose was carried by aircraft of II. Gruppe Jagdgeschwader 5.

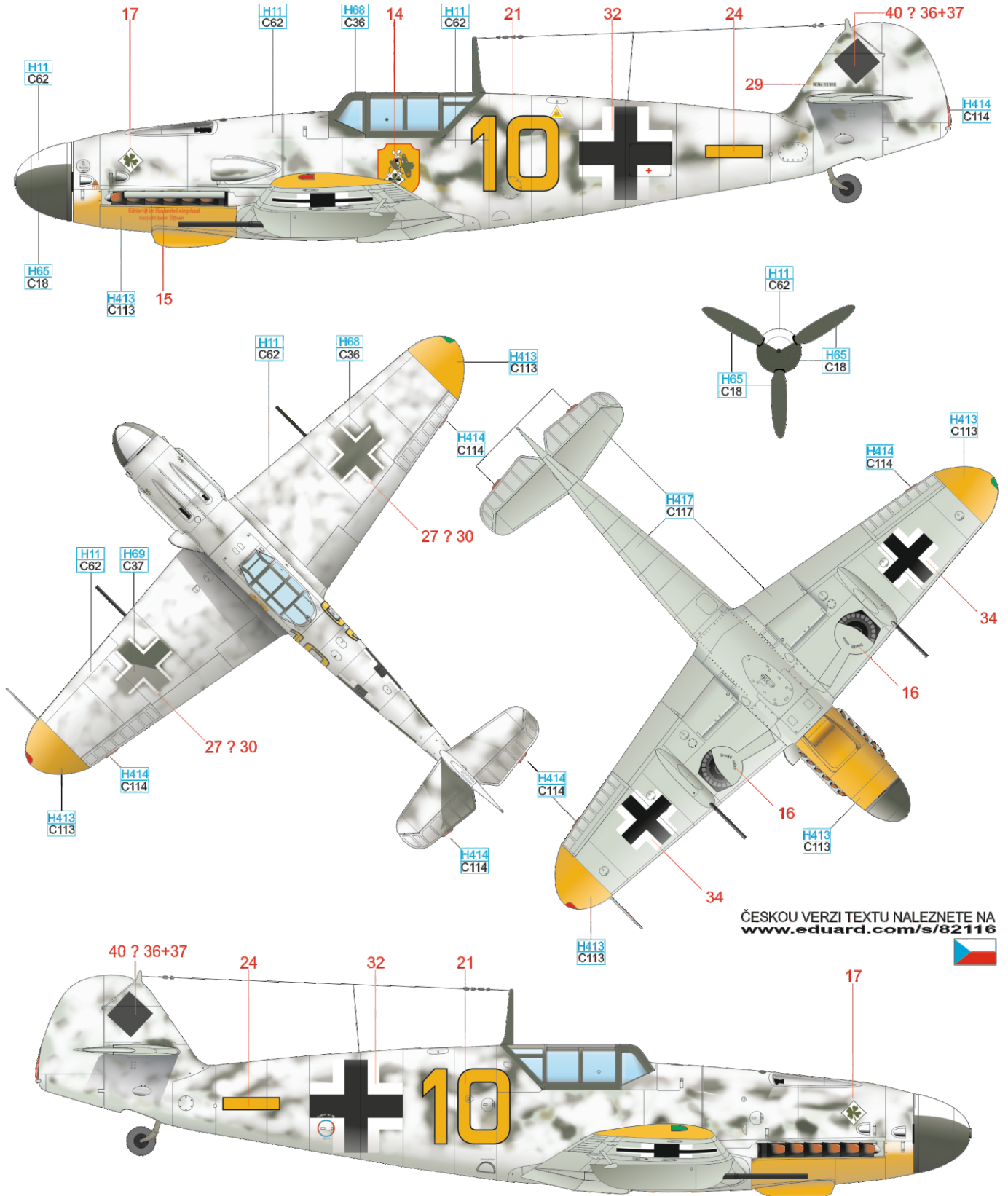

ČESKOU VERZI TEXTU NALEZNETE NA www.eduard.com/s/82116

WHITE	H11 C62	RLM 23	H414 C114	RLM 70	H65 C18
RLM 04	H413 C113	RLM 74	H68 C36	RLM 75	H69 C37
				RLM 76	H417 C117

D Bf 109G-2/R6 W. Nr. 13949, Mjr. Hans Hahn, II./ JG 54, Rjelbitzy, Soviet Union, January 1943

Hans Hahn, a fighter ace and holder of the Knight's Cross with Oak Leaves, held a list of command positions throughout his career. From December 1939, he commanded 4./JG 2, and from October 29th, 1940 he led III./JG 2. Starting on November 1st, 1942, he took over command of II./JG 54, and he commanded this Gruppe up to February 21st, 1943, when he was shot down and taken prisoner by the Soviets. He wasn't freed until 1950. At the time of his capture, he had attained 108 kills, 66 of which were on the Western Front. According to Russian sources, 'Assi' Hahn was shot down by Soviet ace Lt. P. Grazhdaninov. Hahn himself noted that after shooting down an La-5, he was hit in the port wing and suffering an overheated engine, he was forced to land behind Soviet lines, where he was captured. The aircraft was oversprayed in white on the upper and side surfaces in order to better suit winter conditions. Double chevron and the horizontal bar on the rear fuselage is the CO marking of II. Gruppe, and this Group's unit emblem appears below the windscreen, and JG 54's Green Heart – Grünherz – marking is also present. The spinner and the lower sides of the engine cowl are also lightly sprayed over in white.

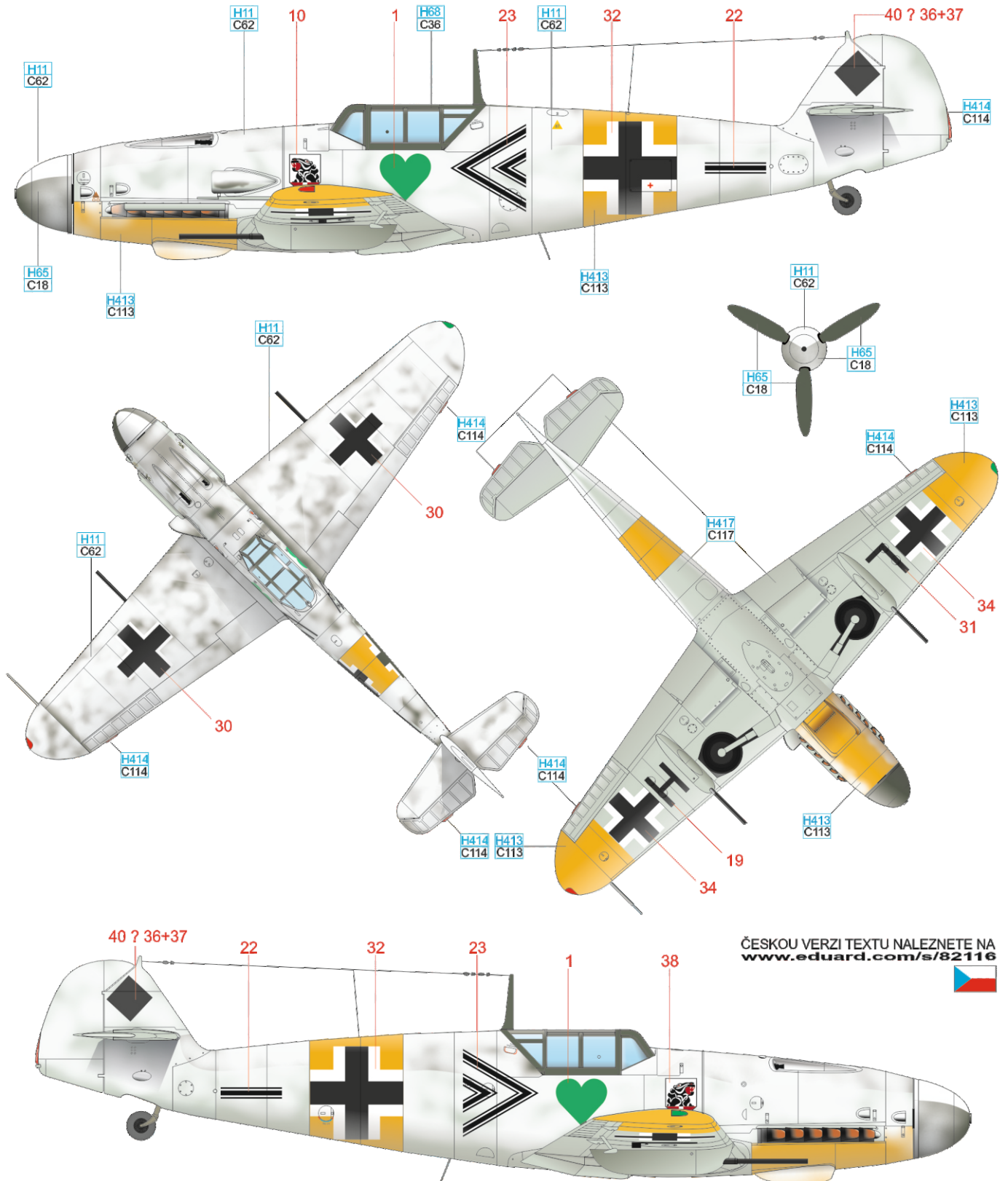

ČESKOU VERZI TEXTU NALEZNETE NA
www.eduard.com/s/82116



WHITE	H11 C62	RLM 23	H414 C114	RLM 70	H65 C18
RLM 04	H413 C113	RLM 74	H68 C36	RLM 75	H69 C37
				RLM 76	H417 C117

