

Tempest Mk.V Series 1

eduard

1/48 Scale Plastic Model Kit

ProfiPACK
edition



item No. 82121

The piston engine aircraft development peaked at the end of the Second World War, bringing some remarkable designs. The Hawker Tempest was one of them. This high performing beast excelled as the mid and low level fighter and attack aircraft.

The story of the Tempest is in fact nothing more than an attempt to sort out the shortcomings of Hawker Typhoon, which prevented the type from being a successful fighter. The main problem of the Typhoon was the thick wing with NACA 22 profile, offering lot of inner space for fuel and armament, but building drag rapidly with rising speed. Not surprisingly was the wing at the core of the changes on the way to the new fighter. The design was originally supposed to retain the Typhoon name marked as the Mark II but as it became obvious, the final result would be a new plane, so the name was changed. The Tempest name followed the path of Hawker to use the "wind" names for its fighters.

Series of changes

The new wing was 5 in (12,7 cm) thinner at the root and the planform changed in comparison with Typhoon wing to more elliptical shape. As the new wing did not offer enough space for fuel, additional fuel tank of 76 gallon (288 l) volume had to be installed in the fuselage. The space for it was found between the firewall and the oil tank, but, consequently, it was necessary to move the engine forward by 21 in (53,4 cm). Due to that, the tail surfaces, both the stabilizer as well as elevator, had to be enlarged, also the undercarriage was rebuilt. All in all, the Tempest really was a new aircraft, although keeping the Typhoon engine, which was a very complex issue by itself. With quite ambitious goals regarding the performance of Tempest, new units were considered instead of troubled Napier Sabre II, but the things went different way...

Back to the roots

Early contract was placed for two prototypes based on the Typhoon airframes powered by Sabre IV engine, but, due to delays with supply, only the HM599 was fitted with it, while HM595 used old Sabre II. The two prototypes also differed in radiator layout as the HM595 retained the distinctive chin radiator of Typhoon, while HM599 undergo radical change as Sydney Camm, Hawker chief designer, attempted to streamline the design. The radiator moved to the leading edge of the inner wing sections on both sides and the sleek nose got some resemblance to the Spitfire. The wing-mounted radiators layout worked well aerodynamically, but the Sabre IV evinced multiple problems, while the complexity of the wing assembly with integrated radiators was of some concern. There were only two other units powerful enough for use with the Tempest instead of Sabre IV: The R&R Griffon and radial Bristol Centaurus IV. As the new name Tempest was chosen, different marks were assigned to each engine variant and four more prototypes were ordered. The Mk.I was to be powered by the Sabre IV (HM599), the Mk.II by the Centaurus IV (LA602 and LA607), the Mk.III by the R&R Griffon IIB (LA610) and the Mk.IV by the Griffon 61 (LA614). Finally, the Mk.V (HM595) used slightly improved version of the Sabre II (IIB) engine producing 2,400 hp (1,790 kW), thus 200 hp (147 kW) more than previous one. Although it was meant as a stopgap solution until Sabre IV engines would be available, it finally emerged as the main mark of the Tempest, because Centaurus

engine supply was too late, Sabre IV was still troubled by glitches and integration of the Griffon into the Typhoon airframe proved to be more demanding than expected, so Mk.III ended with first and only prototype, while Mk.IV was never built.

Legend is born

The HM595 prototype with Sabre II flew for the first time on September 2, 1942, fitted with car door canopy, as the bubble canopy was in development at the time. Streamlined HM599 with Sabre IV performed its maiden flight on February 24, 1943. It was quite faster than HM595, but the solution of its problems would take too much time. The easiest way to get the Tempest into the service was to proceed with the Mk.V.

The first production Tempest Mk.V made its maiden flight on June 21, 1943, already fitted with bubble canopy. Armed with four 20mm Hispano Mk.II cannon (200 rounds per barrel) it achieved a top speed of 432 mph (695 km/h) at 18,400 feet (5,600 m), up to 45 mph (72 km/h) more than Bf 109 od Fw 190 (depending on mark). After the first production batch, the Hispano Mk. V cannons were installed, differentiating the Tempest from the first batch by barrels fully covered by the wing.

The first squadron to receive Tempests was No. 486 in January 1944. Together with No. 3 Squadron it became operational in April 1944. With addition of No. 56 Squadron the first Tempest Wing was formed at Newchurch, Kent, under the command of W/C Roland Prosper „Bee“ Beamont.

Fighting everything

After the period of operations over the France following the D-Day, the Tempest Wing was tasked to fight the V-1 Flying Bombs travelling low at speed of some 400 mph (640 km/h). The Tempest Mk.V was never effective high-level fighter due to the nature of its engine, but at the middle and low levels it was superior to virtually everything. And some 640 destroyed V-1s during the short period between June and August 1944 speak by themselves, as the rest of RAF scored some 160 of them during the period.

After the V-1 bombing campaign ceased, the Tempest Squadrons returned to the common tasks. At the time, seven Tempest squadrons flew air-to-air combats, claiming 240 kills (20 of them being Me 262 jets). Most successful Tempest ace, D. C. Fairbanks (US) recorded 11 kills flying Mk. V „Terror of Rheine“. Second with nine kills came W. E. Schrader (NZ) with nine and J. J. Payton with six kills emerged as third overall. The most famous Tempest Pilot, the Free French Pierre Clostermann, added four kills to his tally of 11 (some sources state 18 kills, the precise number is unknown) flying the Tempest.

Hawker Tempest was formidable fighter, fast, tough, with powerful weapons. Thanks to the excellent low altitude performance, the strafing attacks were also quite common, usually during the „search and destroy“ rides. Apart of cannons, the provision of two 1,000lb (450kg) bombs or eight 60lb (27kg) rockets added to its destructive force.

ATTENTION



UPOZORNĚNÍ



ACHTUNG



ATTENTION



注意



Carefully read instruction sheet before assembling. When you use glue or paint, do not use near open flame and use in well ventilated room. Keep out of reach of small children. Children must not be allowed to suck any part, or pull vinyl bag over the head.



Před započítím stavby si pečlivě prostudujte stavební návod. Při používání barev a lepidla pracujte v dobře větrané místnosti. Lepidla ani barvy nepoužívejte v blízkosti otevřeného ohně. Model není určen malým dětem, mohlo by dojít k požití drobných dílů.

INSTRUCTION SIGNS * INSTR. SYMBOLS * INSTRUKTION SINNBILDEN * SYMBOLES * 記号の説明

OPTIONAL
VOLBABEND
OHNOUTSAND
BROUSITOPEN HOLE
VYVRTAT OTVORSYMETRICAL ASSEMBLY
SYMETRICKÁ MONTÁŽREMOVE
ODŘÍZNOUTREVERSE SIDE
OTOČITAPPLY EDUARD MASK
AND PAINT
POUŽIT EDUARD MASK
NABARVIT

PARTS



DÍLY



TEILE



PIÈCES



部品

PLASTIC PARTS

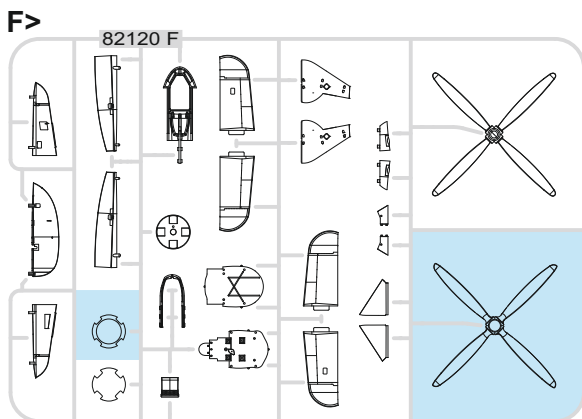
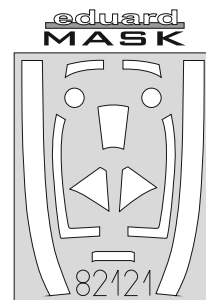
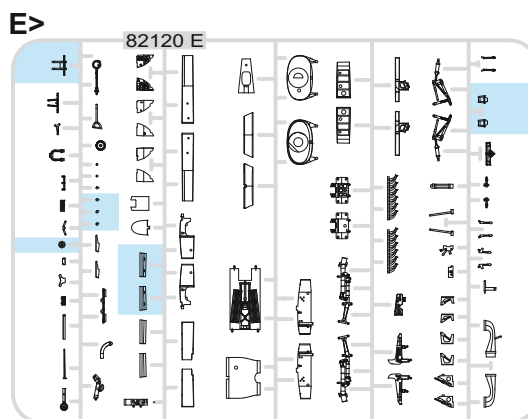
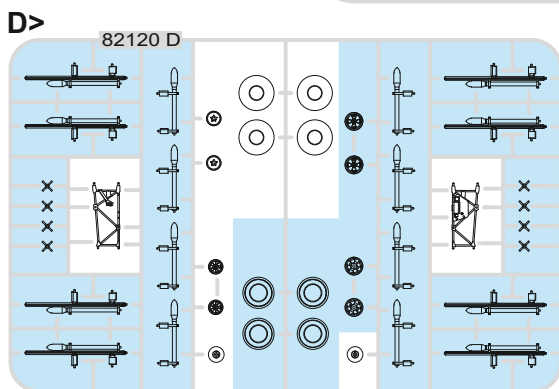
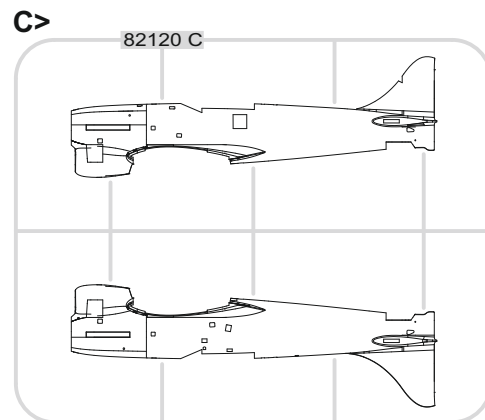
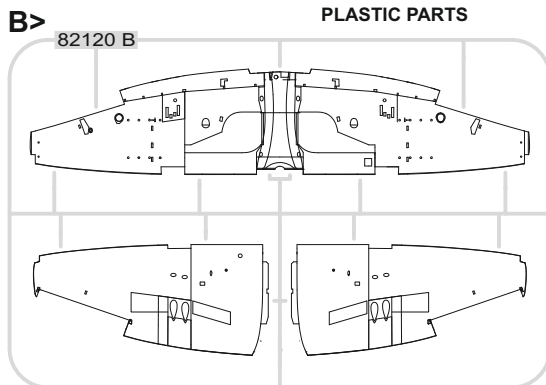
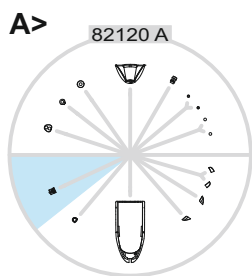

PE - PHOTO ETCHED DETAIL PARTS

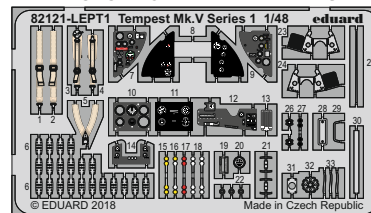

-Parts not for use. -Teile werden nicht verwendet. -Pièces à ne pas utiliser. -Tyto díly nepoužívejte při stavbě. - 使用しない部品

COLOURS



BARVY



FARBEN



PEINTURE



色

| GSI Creos (GUNZE) | | MISSION MODELS | |
|-------------------|----------|----------------|-------------|
| AQUEOUS | Mr.COLOR | PAINTS | |
| H4 | C4 | MMP-007 | YELLOW |
| H8 | C8 | | SILVER |
| H11 | C62 | MMP-001 | FLAT WHITE |
| H12 | C33 | MMP-047 | FLAT BLACK |
| H74 | C368 | MMP-080 | SKY |
| H77 | C137 | MMP-040 | TIRE BLACK |
| H90 | C47 | | CLEAR RED |
| H94 | C138 | | CLEAR GREEN |

| GSI Creos (GUNZE) | | MISSION MODELS | |
|-------------------------|----------|----------------|---------------------|
| AQUEOUS | Mr.COLOR | PAINTS | |
| H330 | C361 | MMP-077 | DARK GREEN |
| H335 | C363 | MMP-094 | MEDIUM SEAGRAY |
| | C362 | | OCEAN GRAY |
| | C364 | MMP-079 | AIRCRAFT GRAY-GREEN |
| Mr.METAL COLOR | | METALLICS | |
| | MC214 | MMM-001 | DARK IRON |
| Mr.COLOR SUPER METALLIC | | METALLICS | |
| | SM01 | MMC-001 | SUPER CHROME |

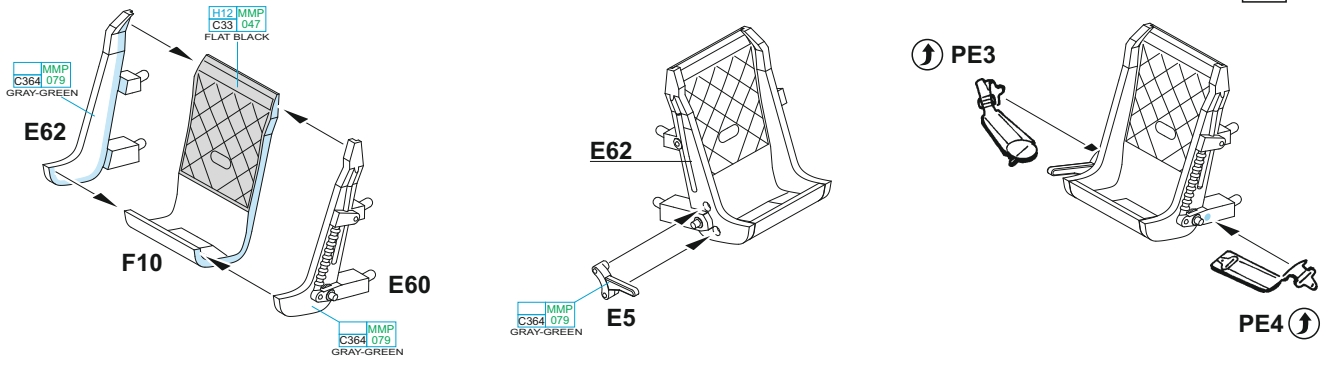
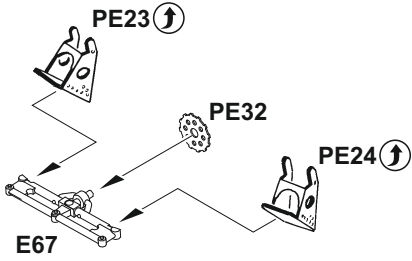
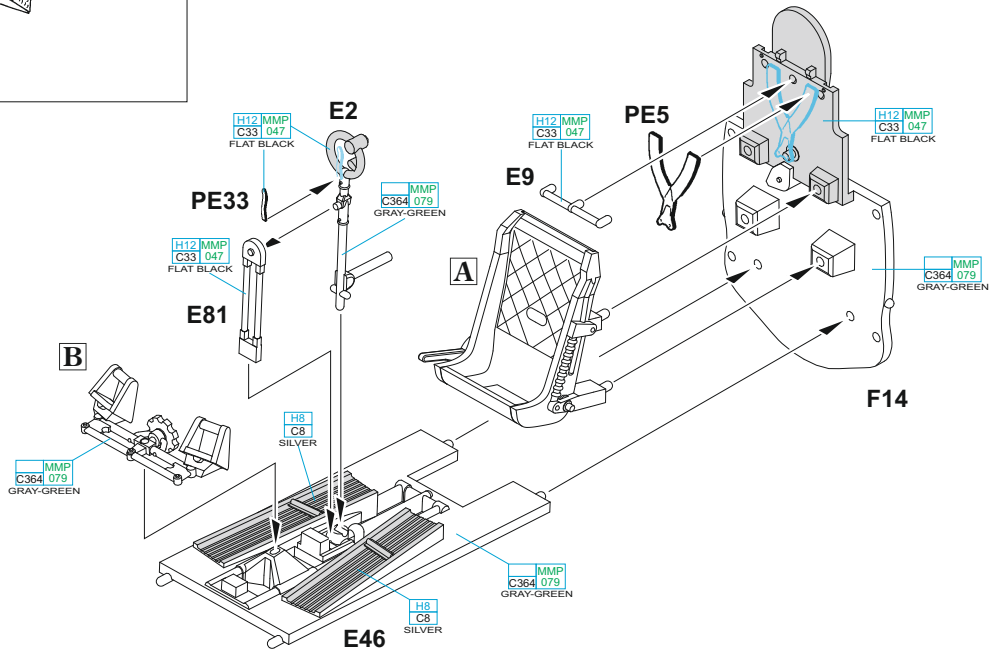
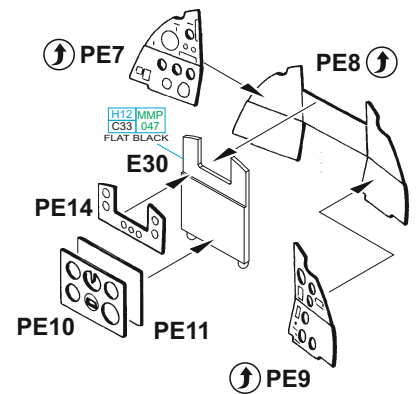
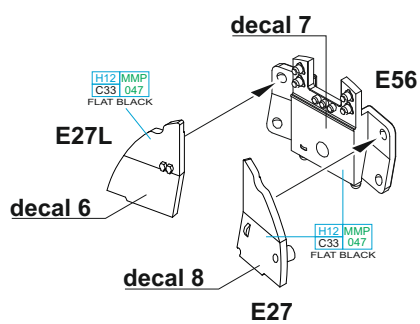
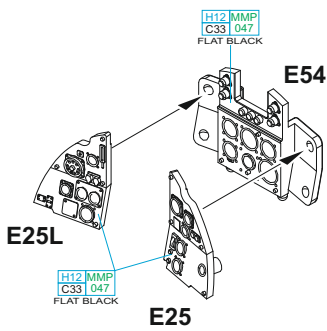
A**B****C****D**

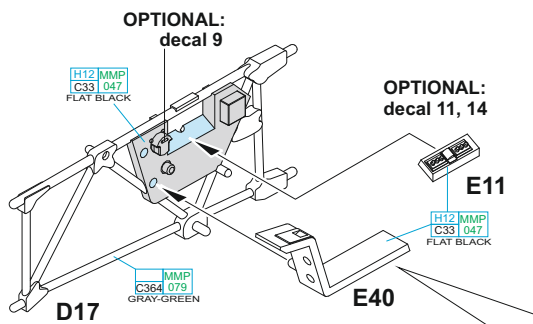
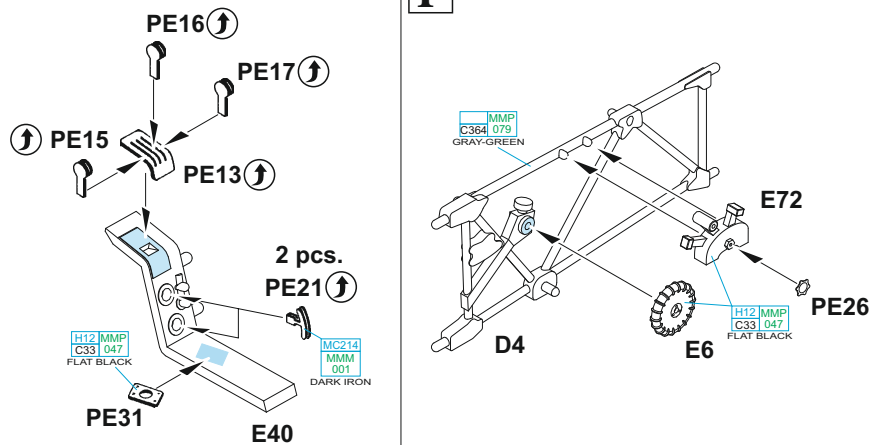
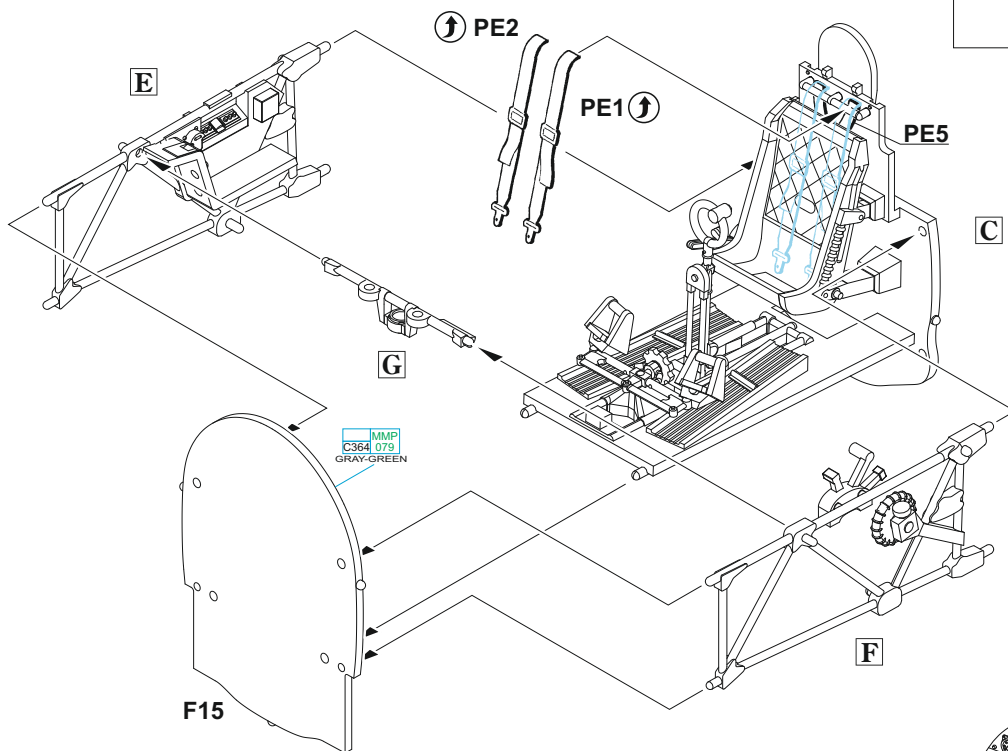
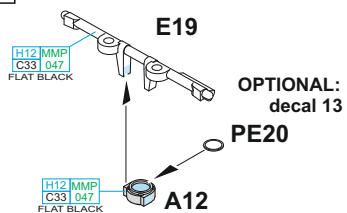
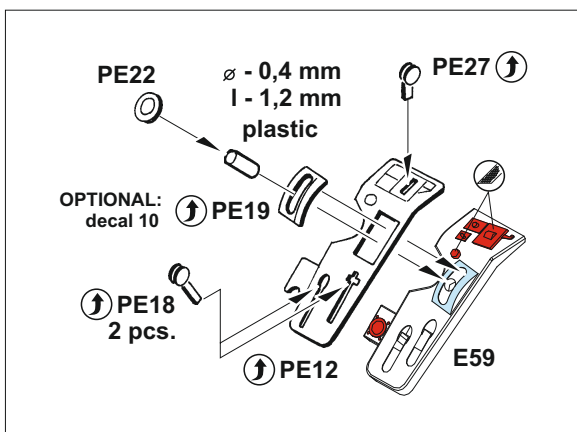
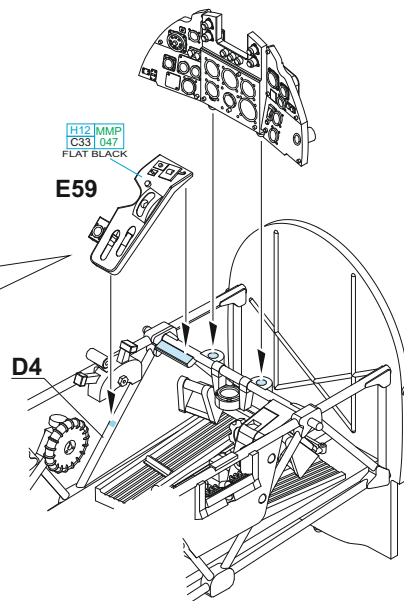
E**F****H****G****D**

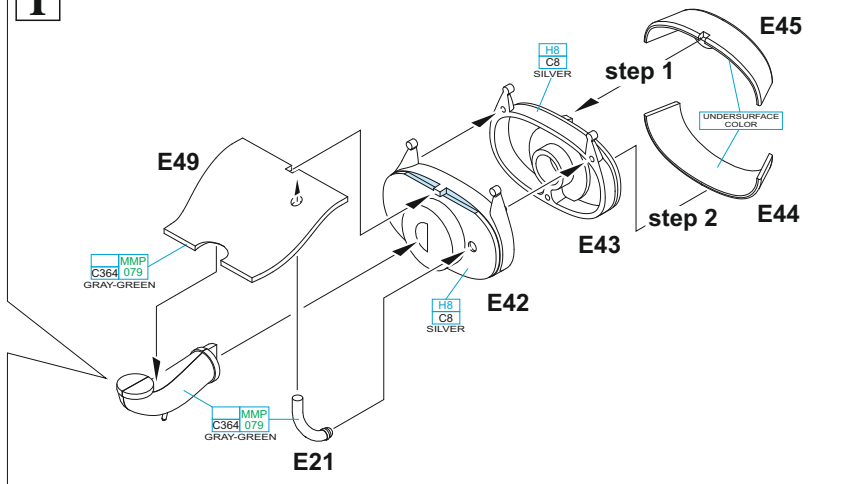
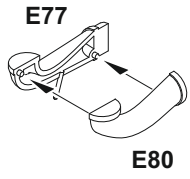
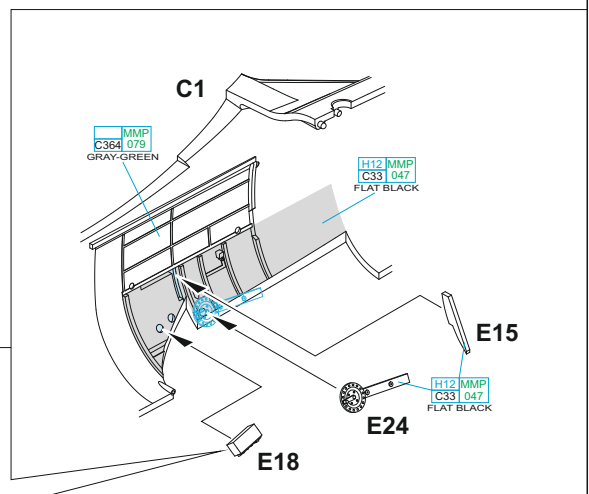
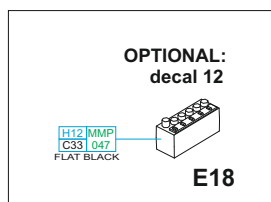
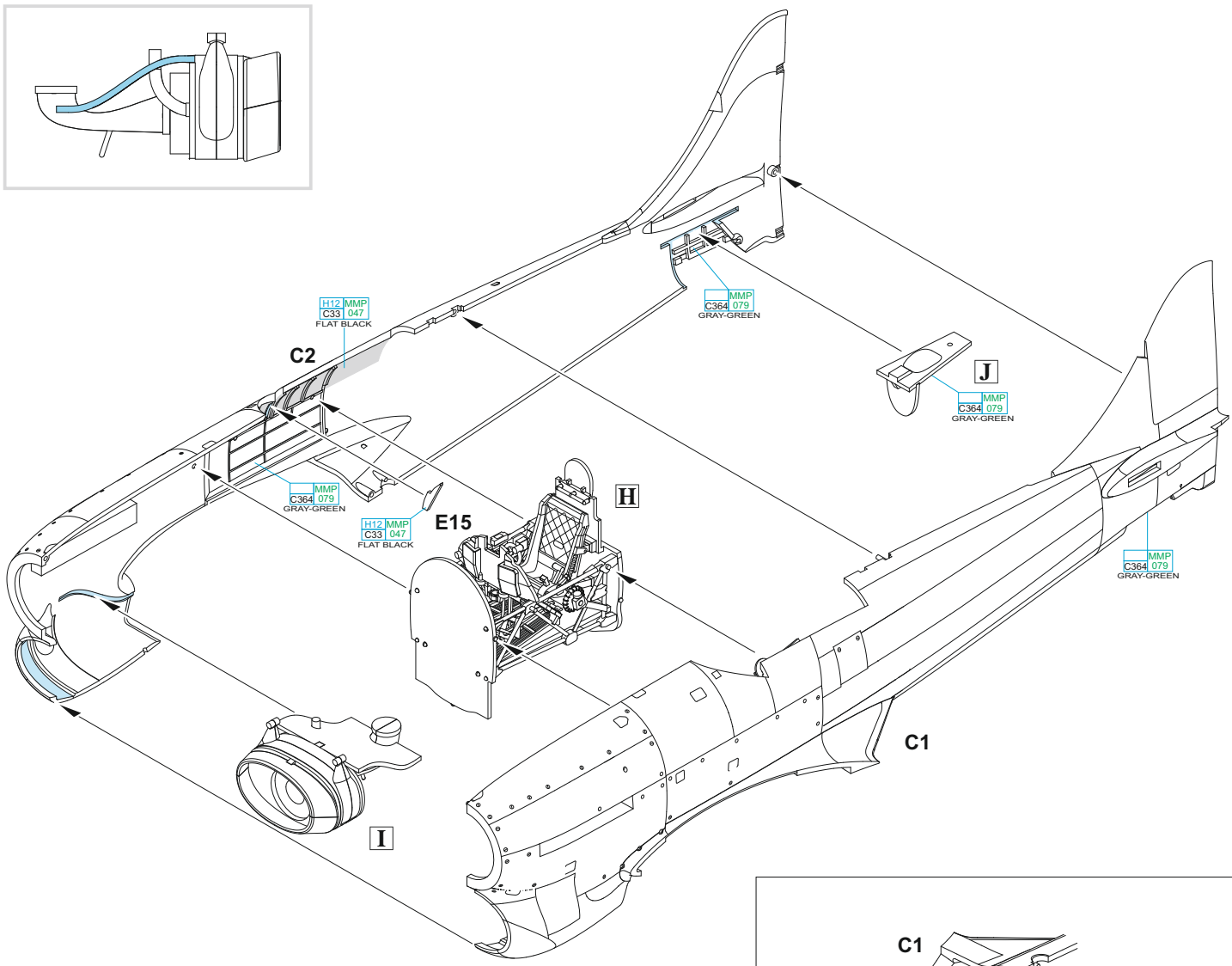
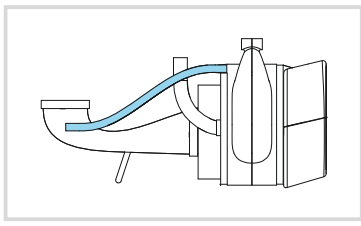
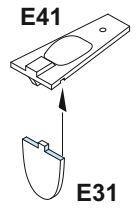
I**J**

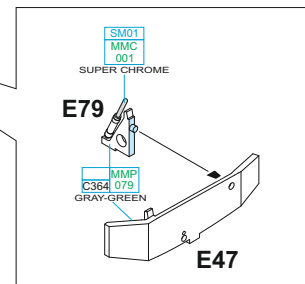
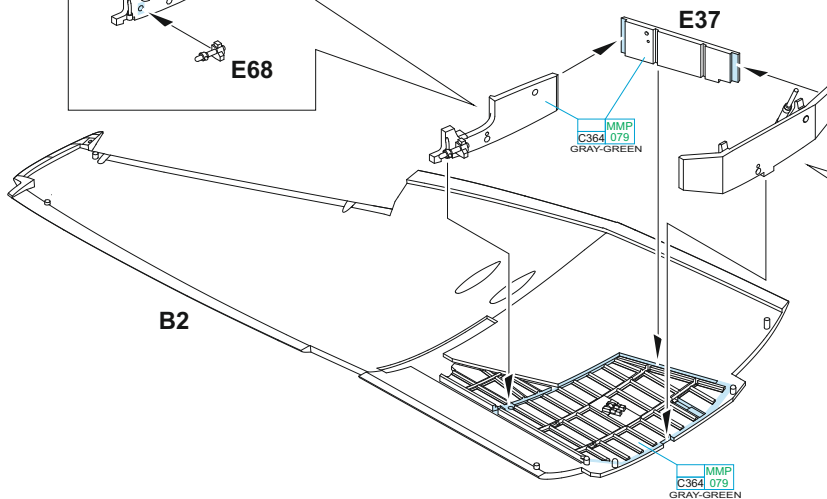
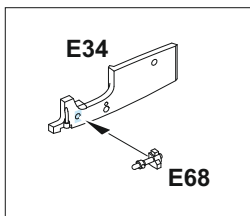
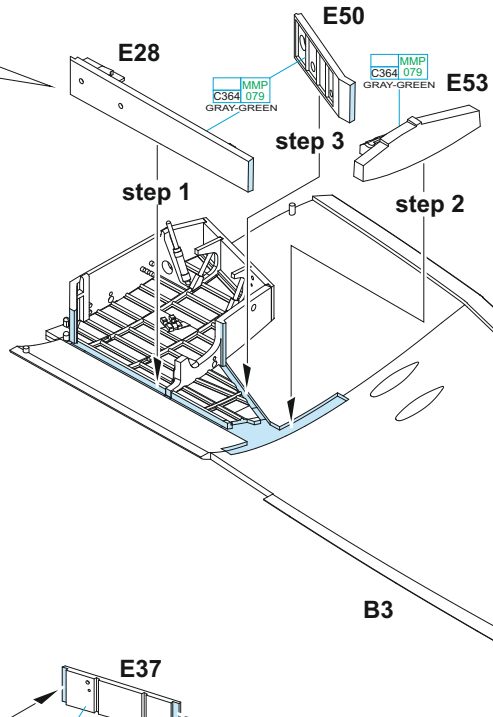
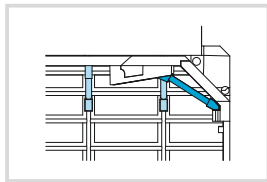
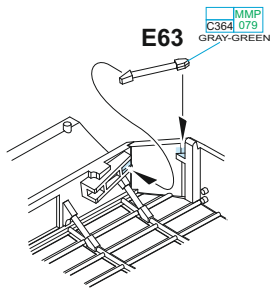
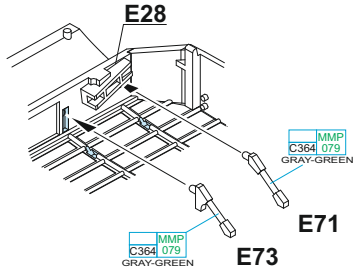
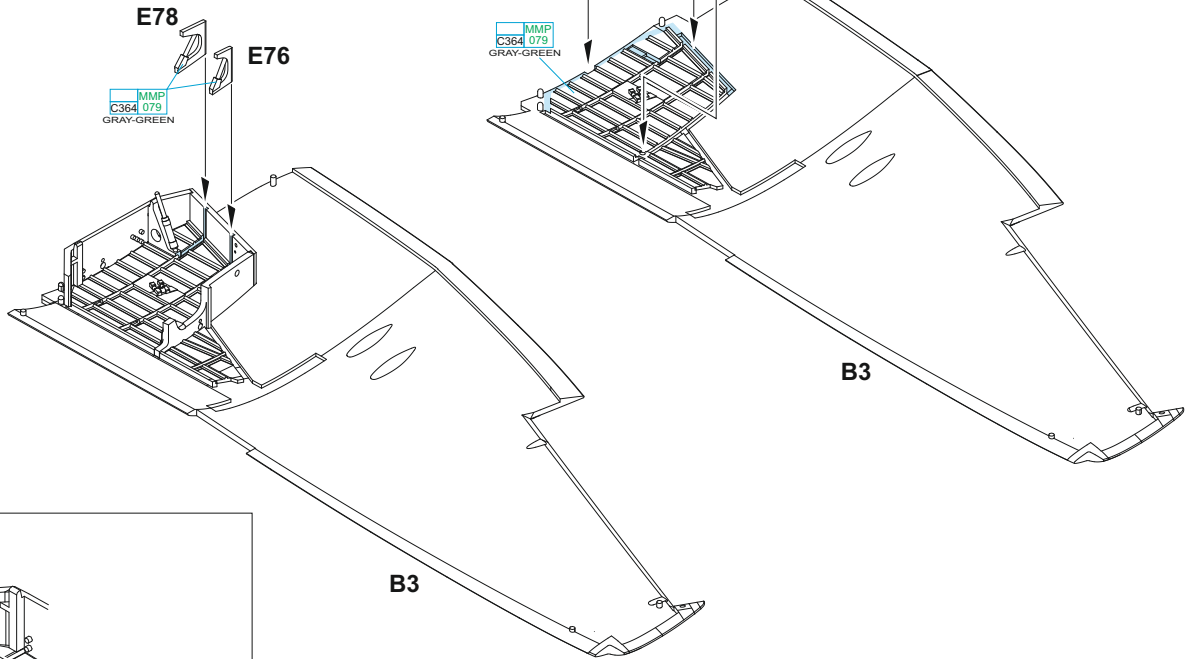
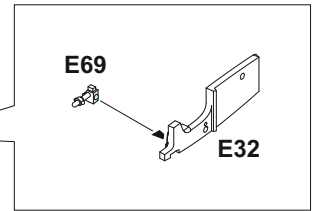
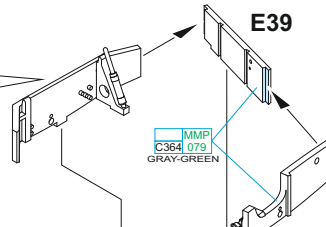
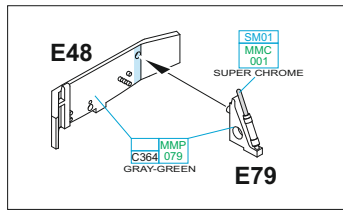

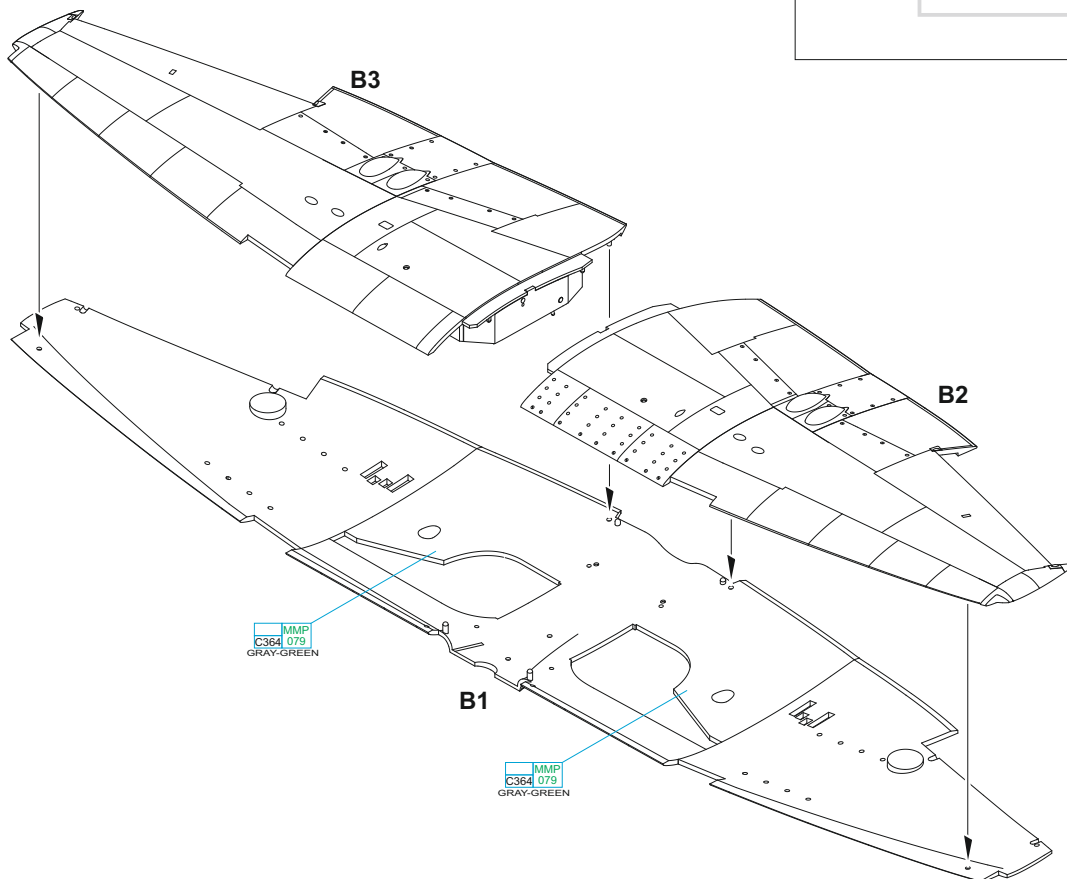
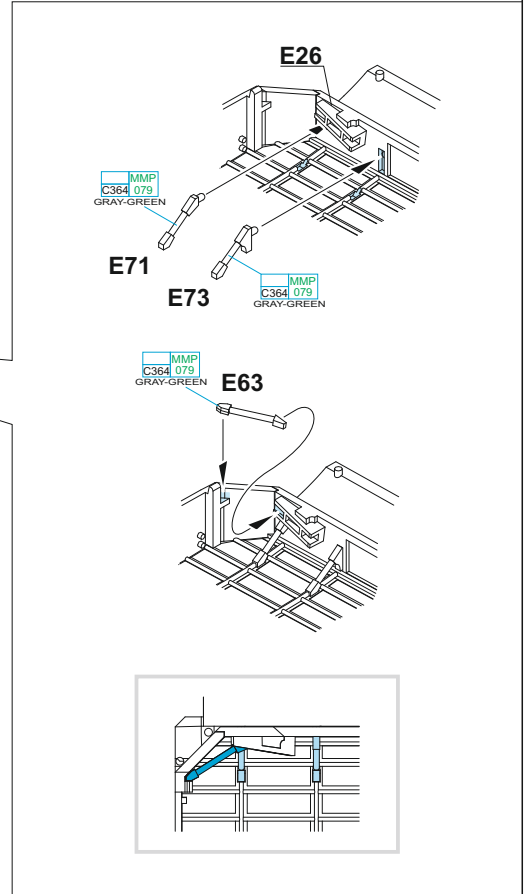
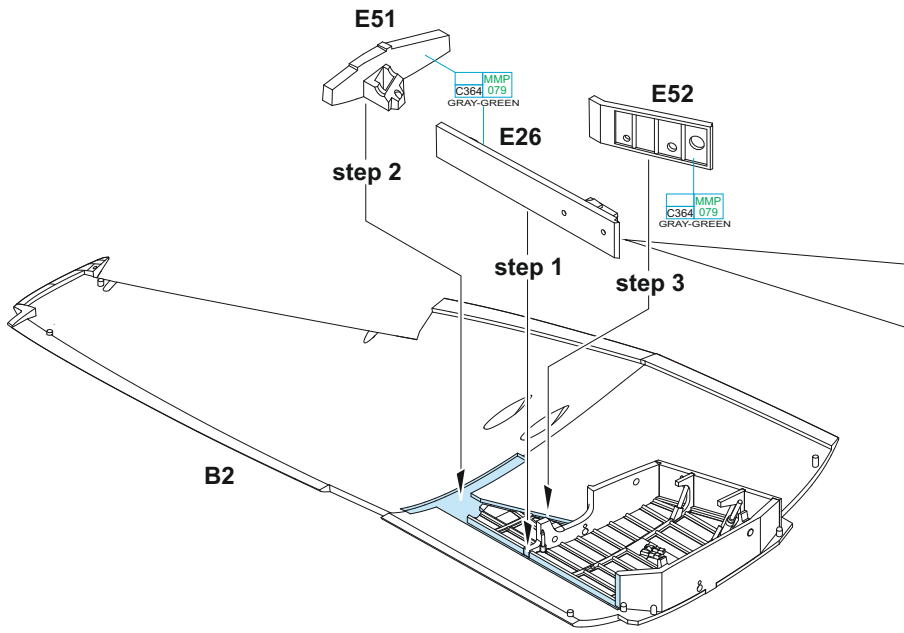
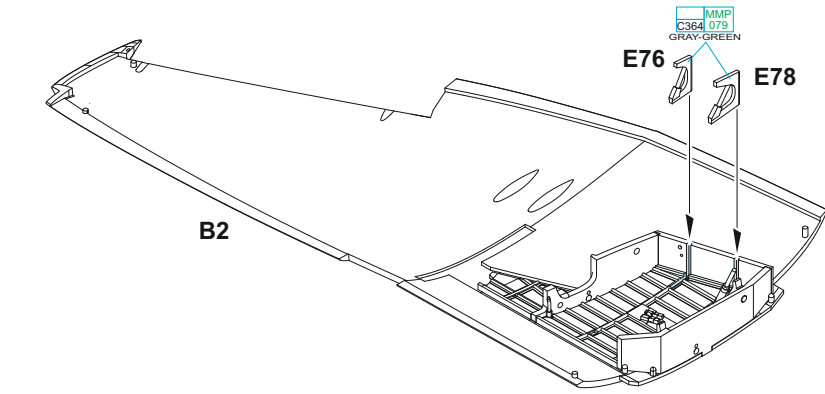

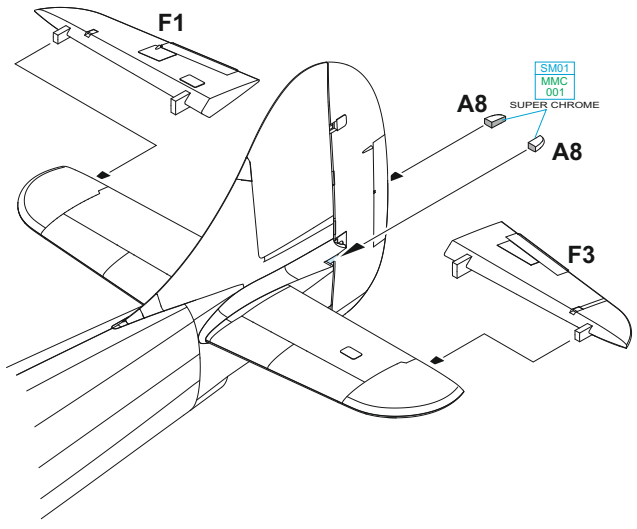
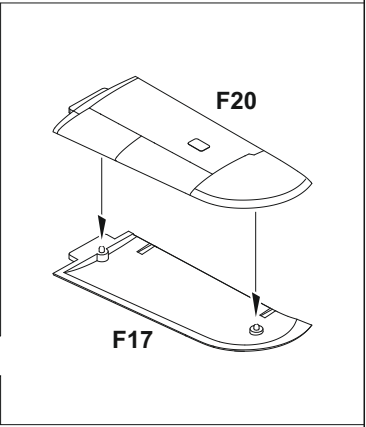
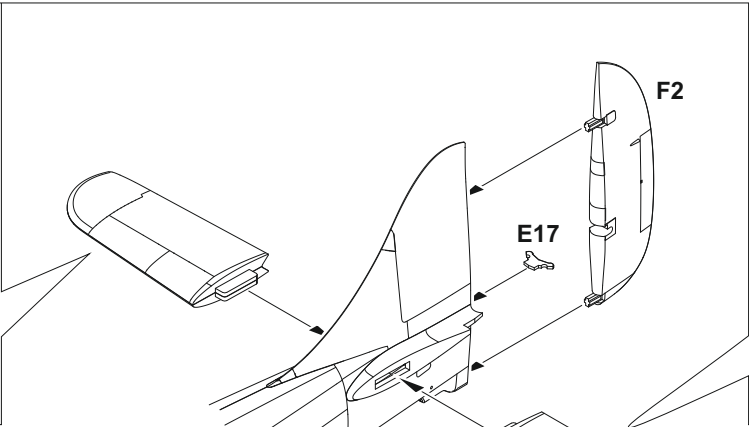
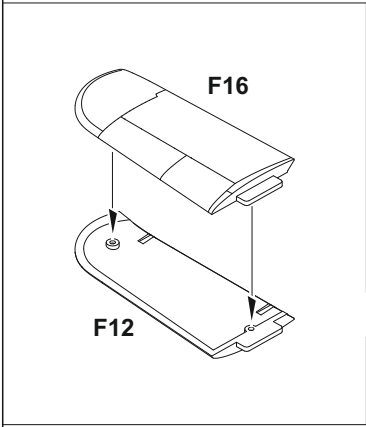
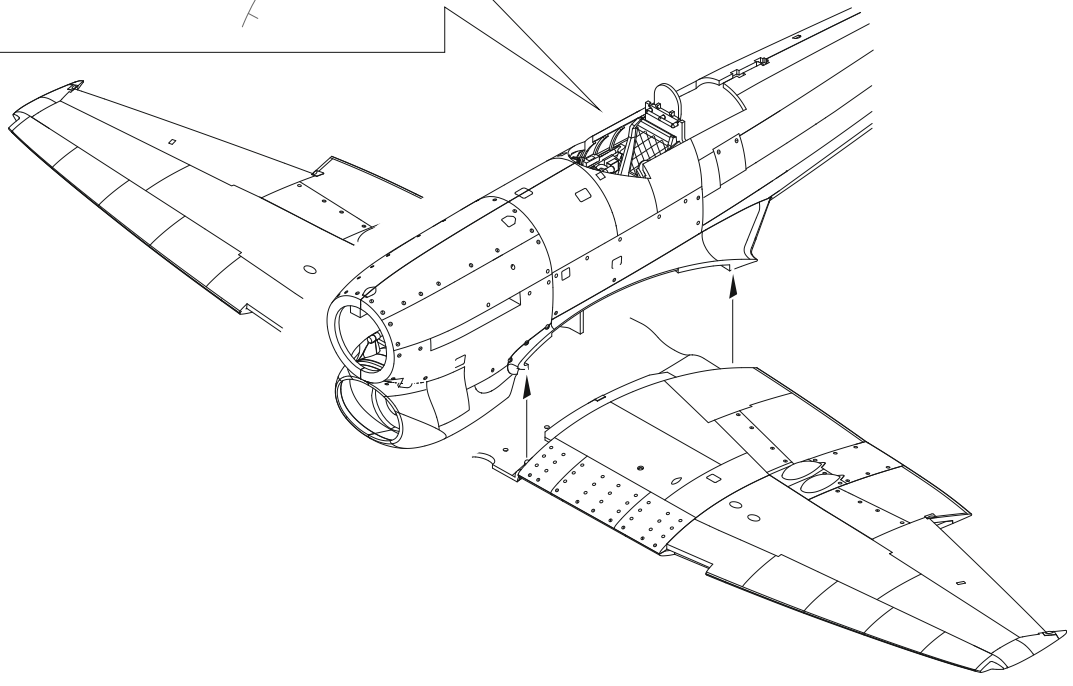
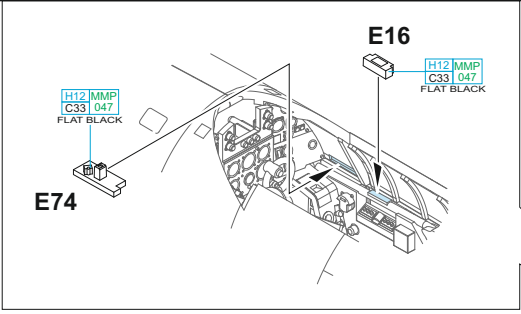

K

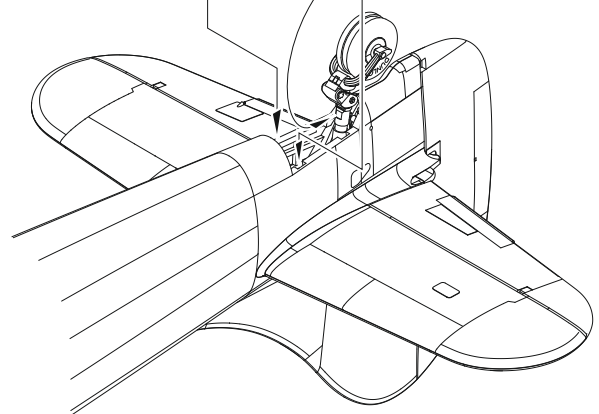
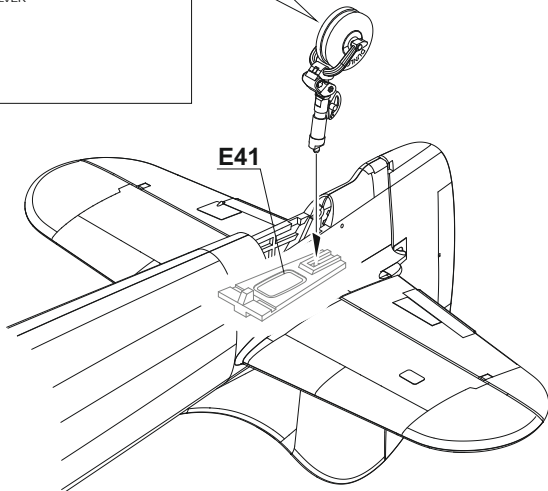
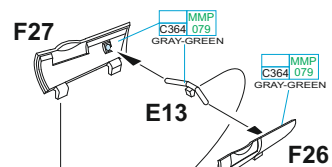
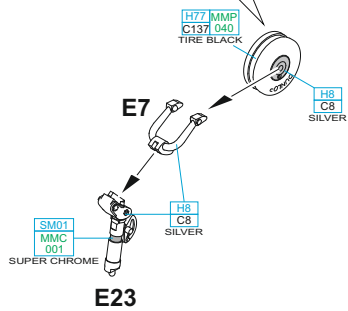
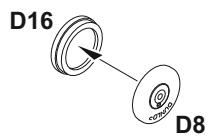
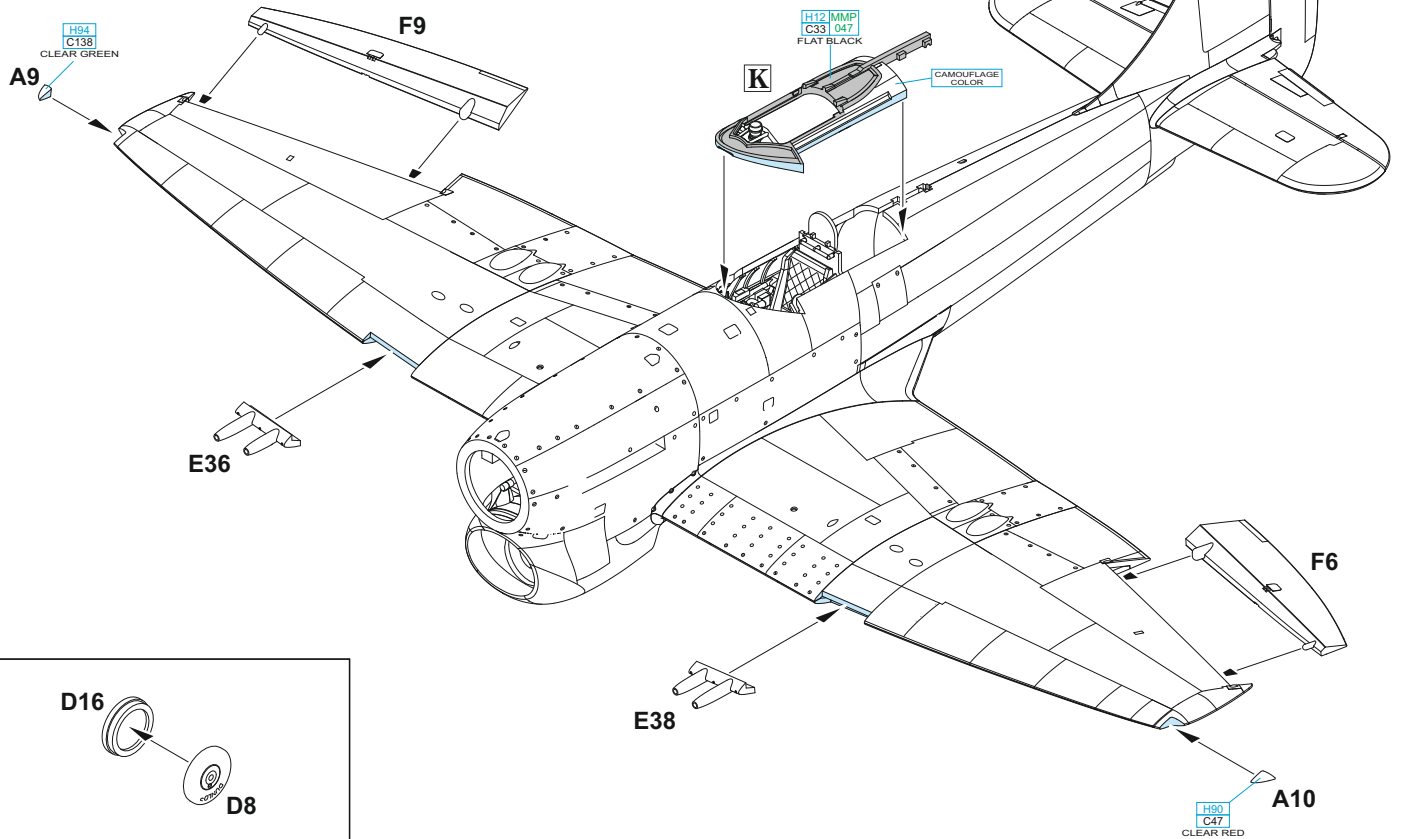
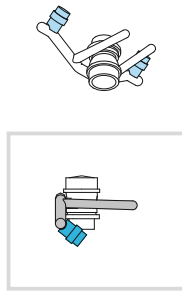
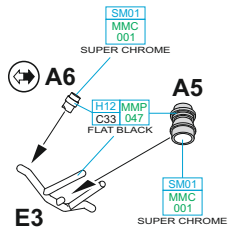
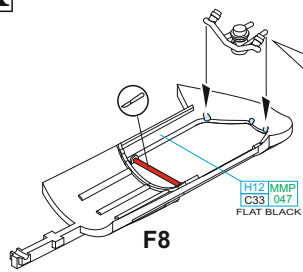

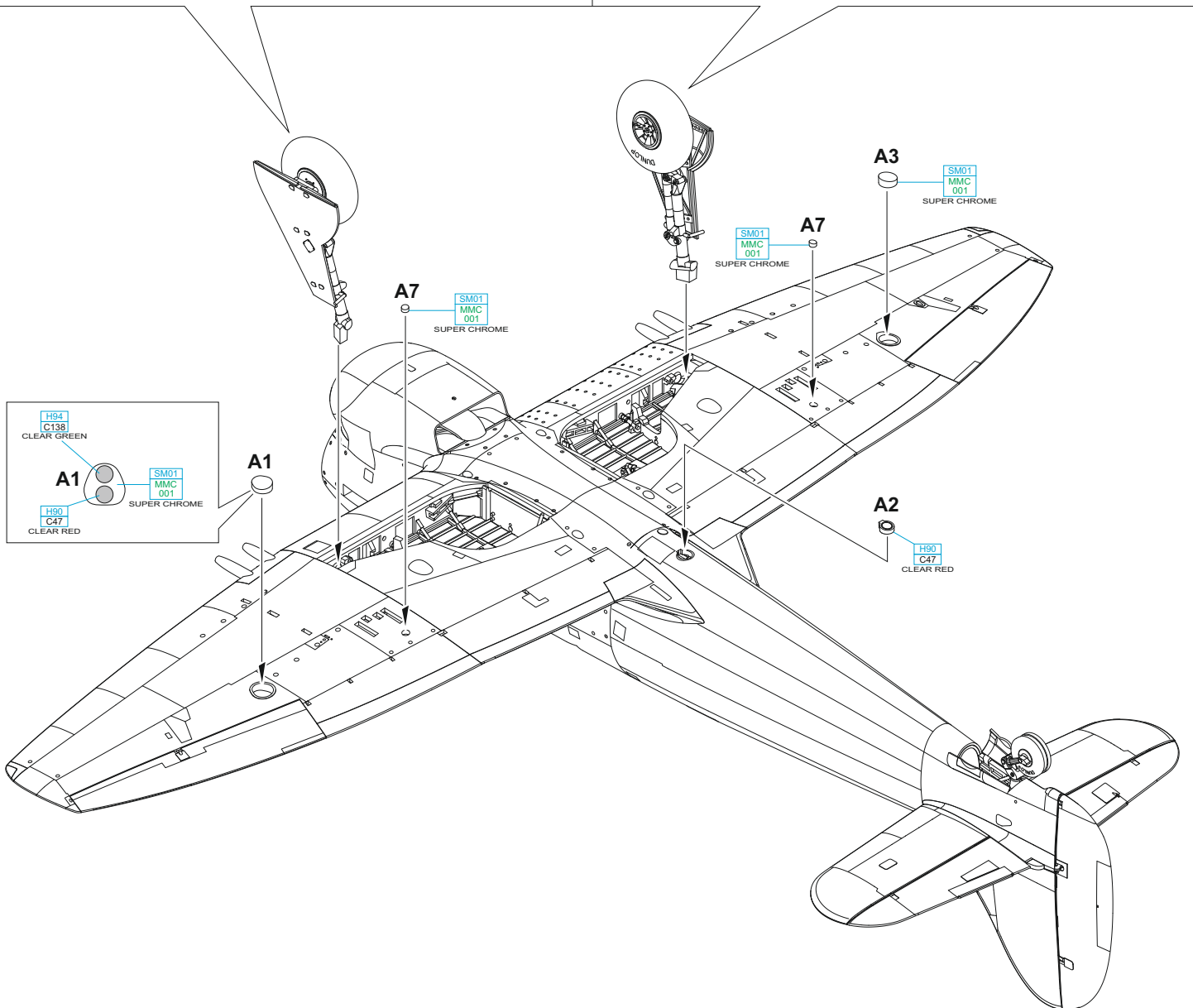
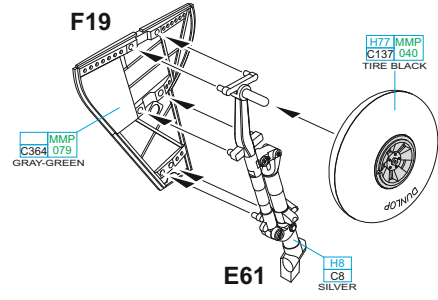
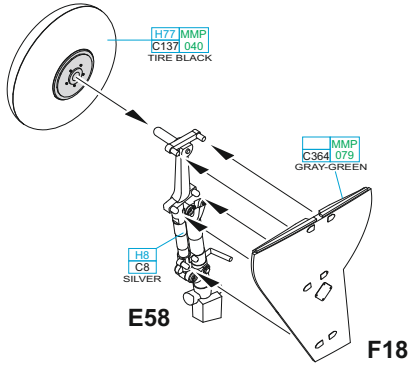
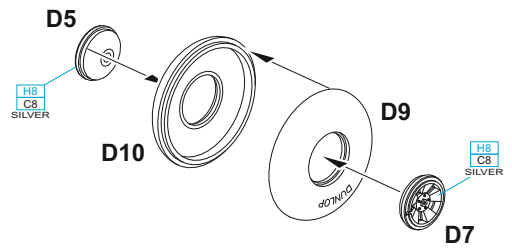
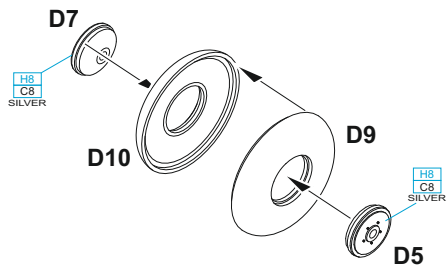

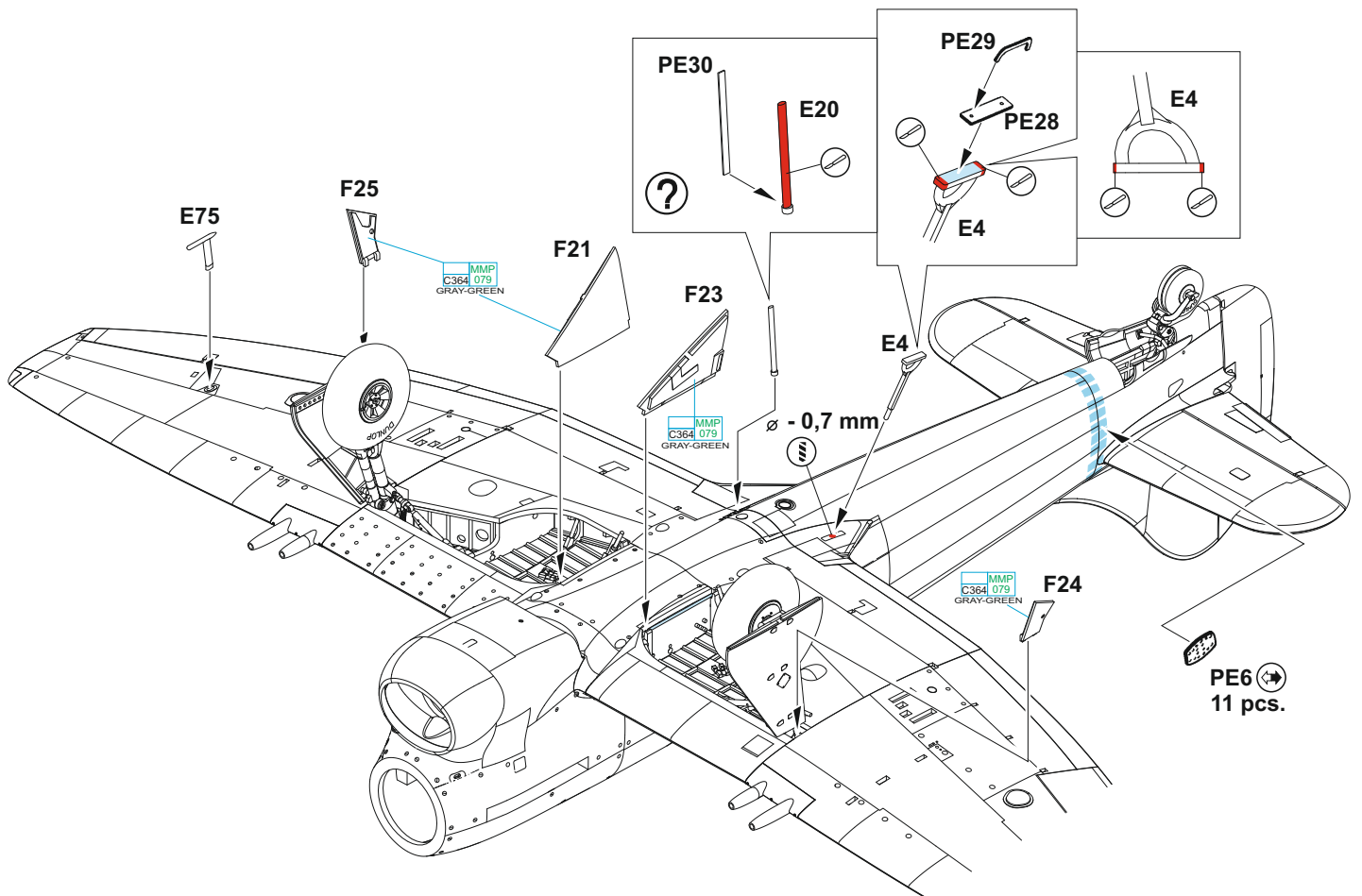
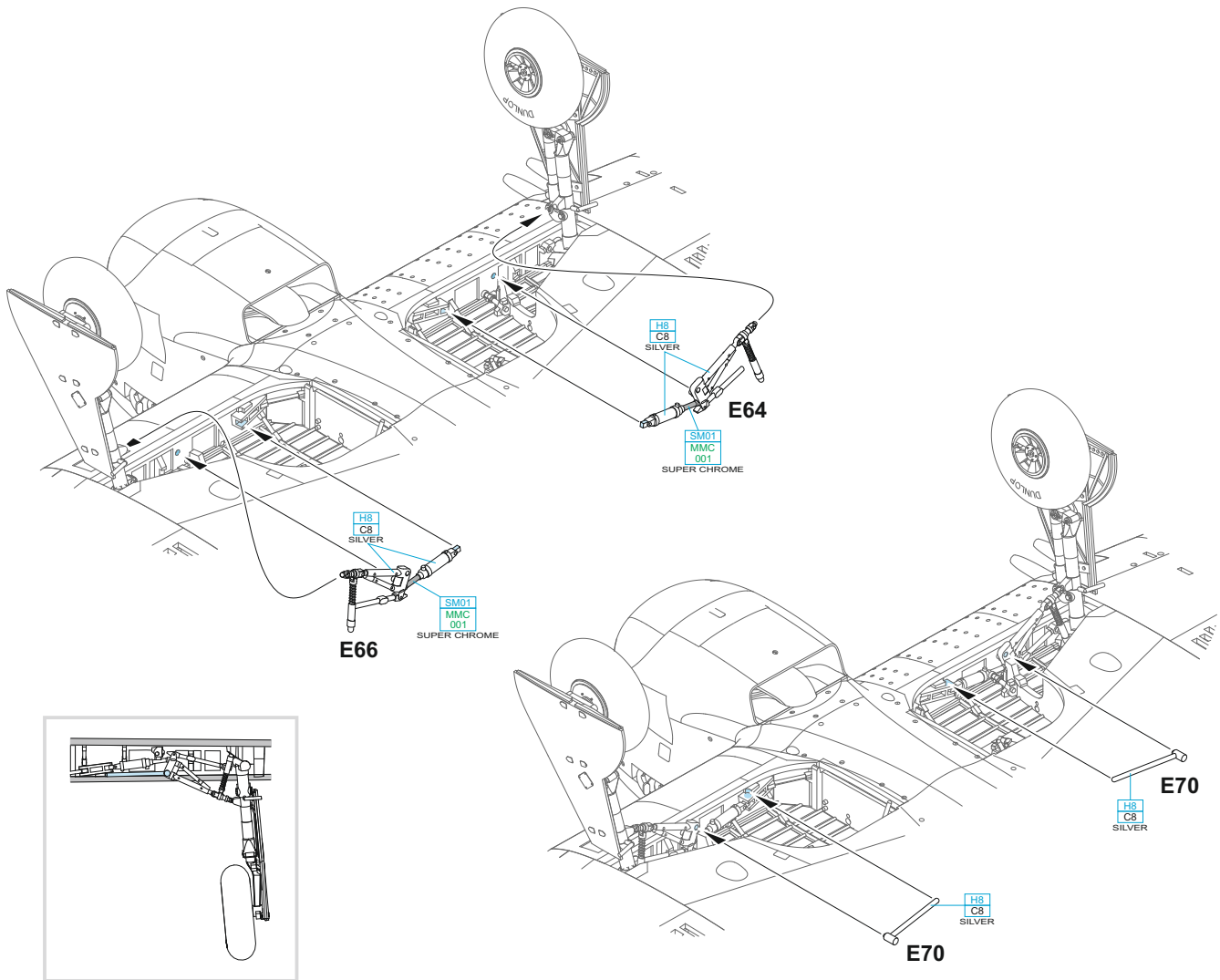

L

H12 MMP
C33 047
FLAT BLACK

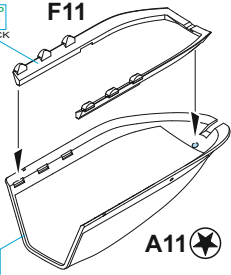

PE25

E22



CLOSED CANOPY

L

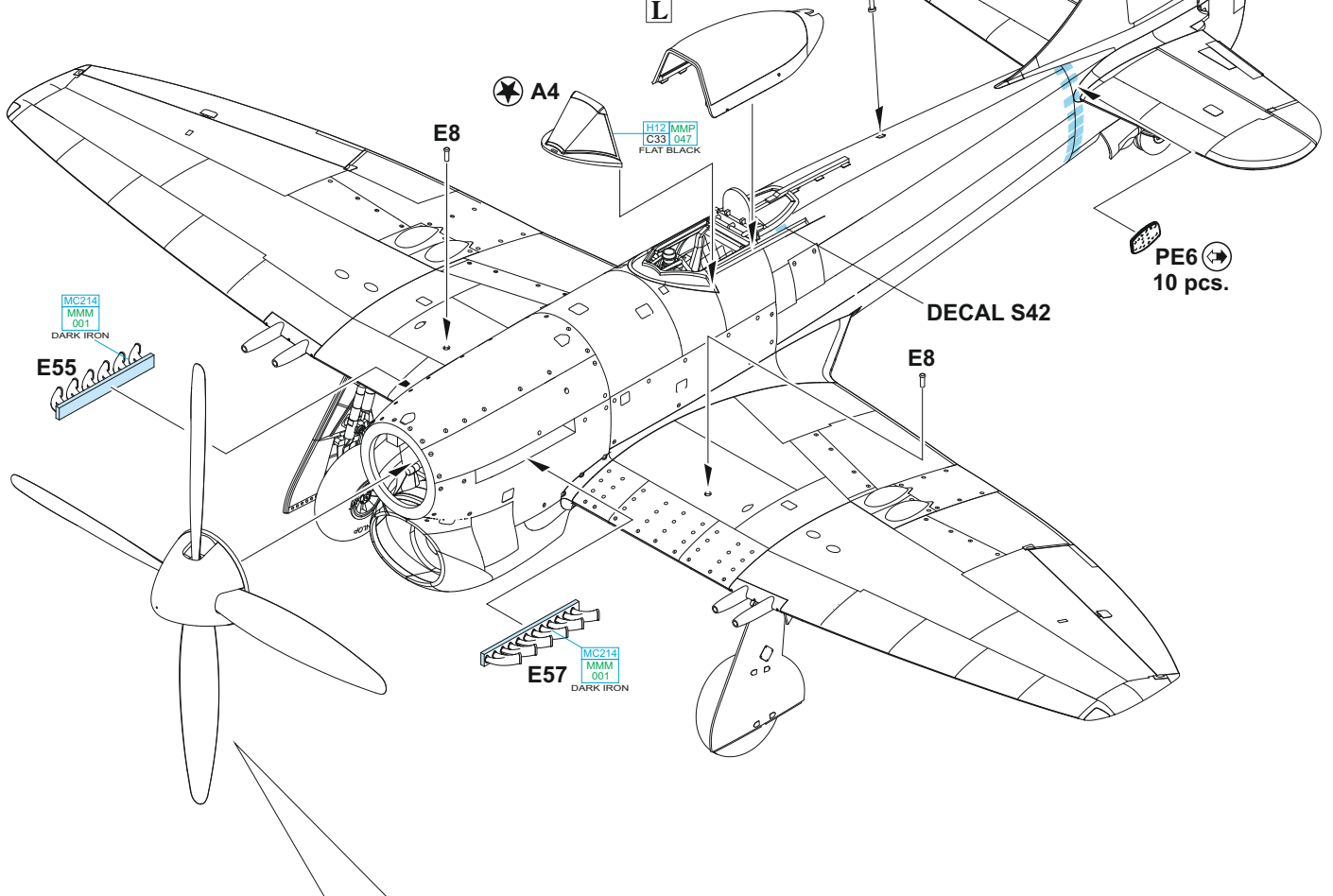

PE6
10 pcs.

DECAL S42

MC214
MMM
001
DARK IRON

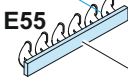

MC214
MMM
001
DARK IRON



OPEN CANOPY

L

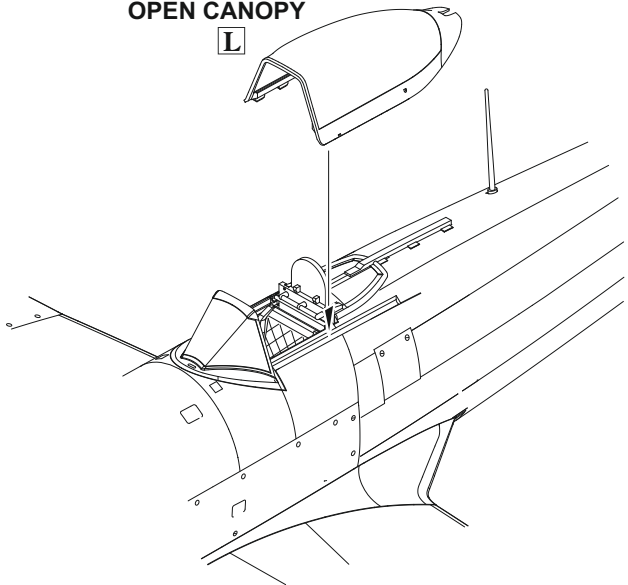

F7

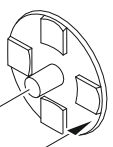

F4



F28

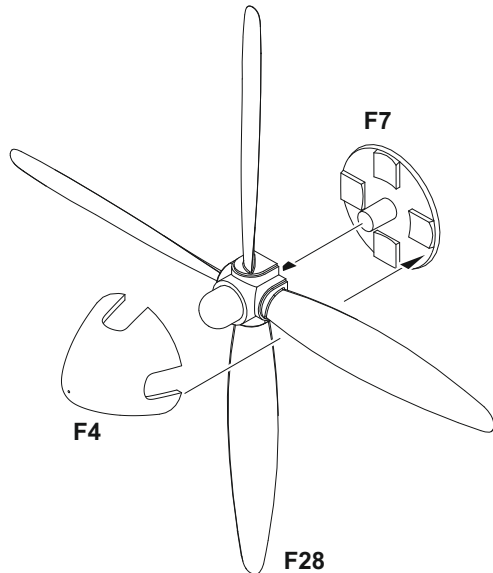

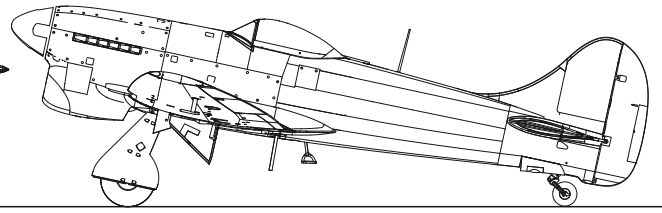
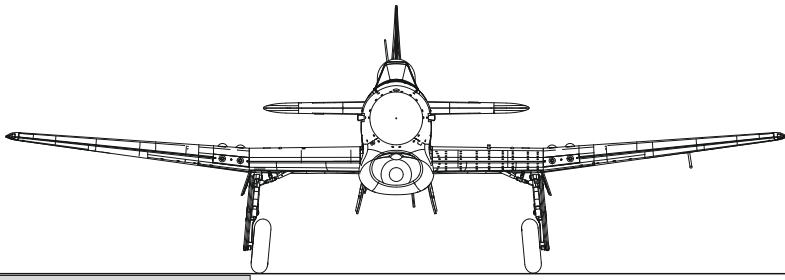

eduard
MASK

82121

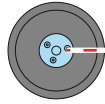

D16

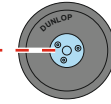
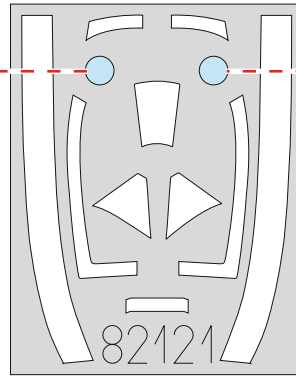

D8

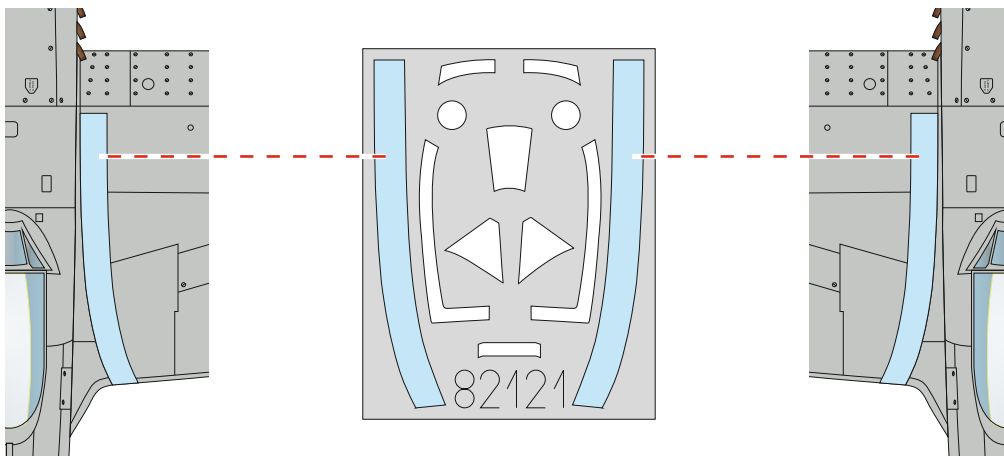
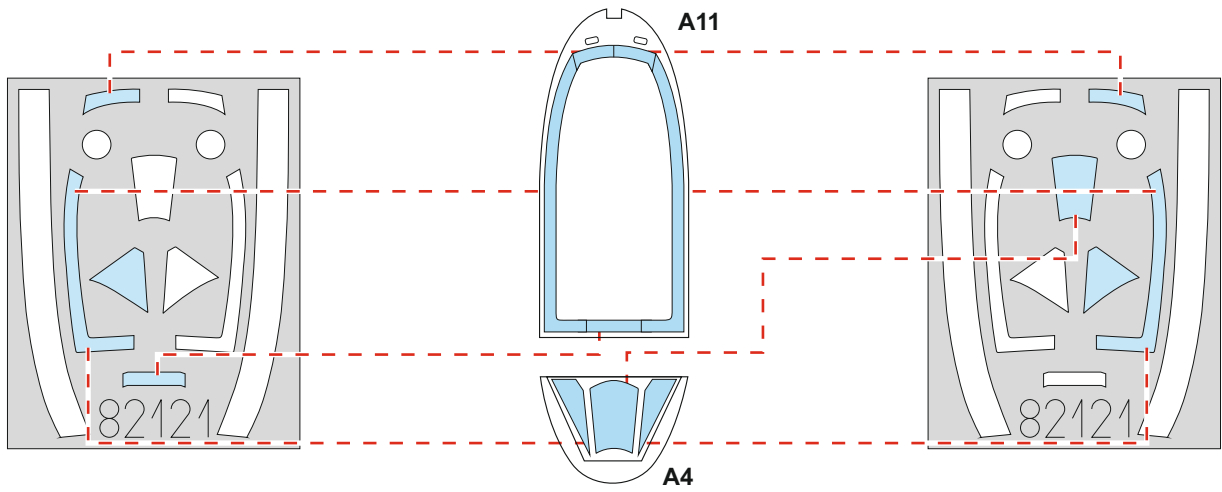

B JN751, W/Cdr Roland P. Beamont, DSO, DFC & bar, CO of No. 150 Wing, RAF Station Bradwell Bay, Great Britain, April 1944

Roland Prosper Beamont was born on August 10, 1920 in Enfield in the County of Middlesex, and aviation captured his imagination at an early age. In 1939, he underwent pilot training and was assigned to No. 87 Squadron, equipped with Hurricanes, where he flew during the Battle of France and Battle of Britain. From May 1941, he served with No. 79 Squadron, and in December of the same year, on completion of his tour, he joined the Hawker factory as a test pilot. In June 1942 he joined No. 56 Squadron flying Typhoons. Subsequently, he was assigned to No. 609 Squadron equipped with the same type as its CO in October 1942. In mid-May 1943, Beamont returned to Hawker, where he took part in trials of the Typhoon and its successor, the Tempest. In February 1944, he was named CO of No. 150 Wing, made up of No. 3, 56 and 486 Squadrons intended to be equipped with the Hawker Tempest. One of the perks of being a Wing Commander was to be allowed to use one's initials for an aircraft code. W/Cdr Beamont made use of this privilege and his personal Tempest carried the letters R and B. Beneath the windscreen on the right side of the fuselage was the Wing Commander insignia.

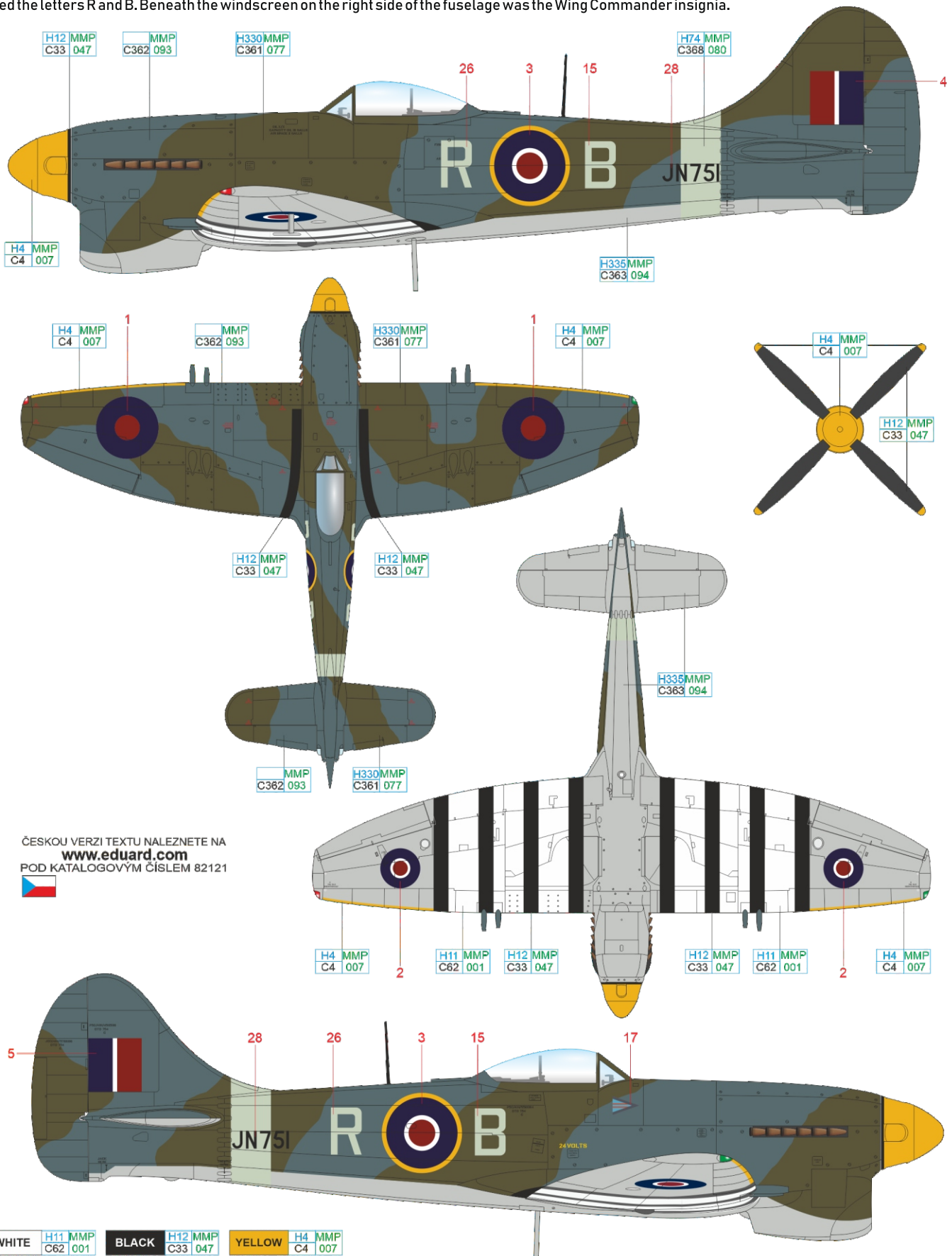

ČESKOU VERZI TEXTU NALEZNETE NA
www.eduard.com
 POD KATALOGOVÝM ČÍSLEM 82121



| | | | | | |
|-----------------|-------------------|------------|-------------------|------------|---------------|
| WHITE | H11 MMP C62 001 | BLACK | H12 MMP C33 047 | YELLOW | H4 MMP C4 007 |
| MEDIUM SEA GRAY | H335 MMP C363 094 | DARK GREEN | H330 MMP C361 077 | OCEAN GRAY | MMP C362 093 |
| | | SKY | H74 MMP C368 080 | | |

C JN755, No. 3 Squadron, Newchurch, Great Britain, May 1944

No. 3 Squadron was formed in 1912 and at the beginning of the Second World War was equipped with the Hawker Hurricanes. As a component of the British Expeditionary Force, it fought over Belgium and France. When back to the Great Britain, the squadron was tasked with patrol duties over the Royal Navy base at Scapa Flow and from April 1941 it operated over southern England as a night fighter unit. In February 1943, the unit was re-equipped with the Hawker Typhoon and a year later with the Tempest. Armed with these "beasts", the unit prepared itself for the invasion to the Europe but was held back to defend southern England against the V-1 flying bombs instead. When the V-1 launch sites were over-run, it was one of the Tempest squadrons transferred to the European mainland to support advancing Allied troops all the way to the end of the war. No. 3 Squadron stayed in Germany until May 1999 as part of the British Air Forces of Occupation (BAFO), 2nd TAF and RAF Germany. From April 20, 1944, the standard camouflaged Tempests did not carry the black and white ID stripes. The code QO was assigned by No. 3 Squadron until June 5, 1944, when they were replaced by the JF code.

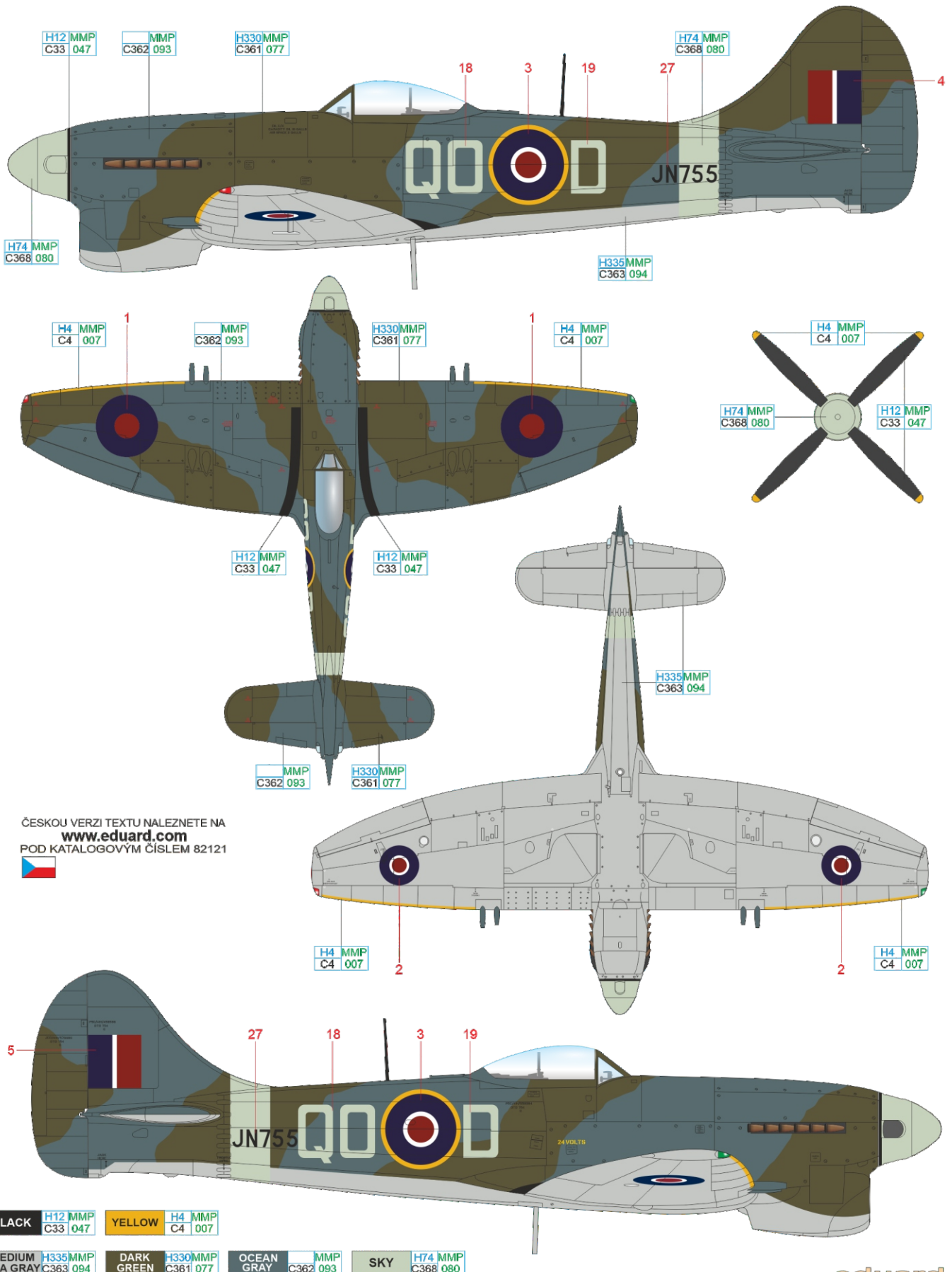

ČESKOU VERZI TEXTU NALEZNETE NA
www.eduard.com
 POD KATALOGOVÝM ČÍSLEM 82121



| | | | |
|-----------------|----------------------|------------|----------------------|
| BLACK | H12 MMP C33 047 | YELLOW | H4 MMP C4 007 |
| MEDIUM SEA GRAY | H335 MMP C363 094 | DARK GREEN | H330 MMP C361 077 |
| OCEAN GRAY | MMP C362 093 | SKY | H74 MMP C368 080 |

D JN751, W/Cdr Roland P. Beamont DSO, DFC & bar, CO of No. 150 Wing, Newchurch, Great Britain, June 1944

In May 1944, No. 150 Wing was deemed operational, although only Nos. 3 and 486 Sqn were equipped with Tempests, while No. 56 Sqn had to wait for them until late June 1944 and used the Spitfire Mk. IXs in the interim. The Tempests of No. 150 Wing were tasked with air cover over the battlefield and attack enemy ground targets at the time of the invasion. Starting from mid-June, the situation changed, as the protection of southern England from V-1 attacks emerged as a priority and the Tempest was the most suitable aircraft for the task. At the end of September 1944, the entire unit led by Beamont moved to liberated Europe. On October 12, Beamont's aircraft was hit by flak and due to a damaged radiator, the pilot had to belly-land it behind enemy lines. He spent the remainder of the war in captivity. Over the course of the Second World War, Beamont claimed nine kills and in July 1944 was awarded a bar to his DSO in recognition of his successful leadership of the Tempest wing which had destroyed more than 600 V-1s (32 by Beamont himself). After the war, he continued as a test pilot and flew, among others, the Meteor, Vampire, Canberra, Lighting and the, most notably, the impressive TSR-2. He retired in August 1979 and died on November 19, 2001. Two days before the invasion of Europe, Beamont's aircraft received the prescribed "Special Markings" - 18-inch wide black and white stripes encircling the rear fuselage and wings.

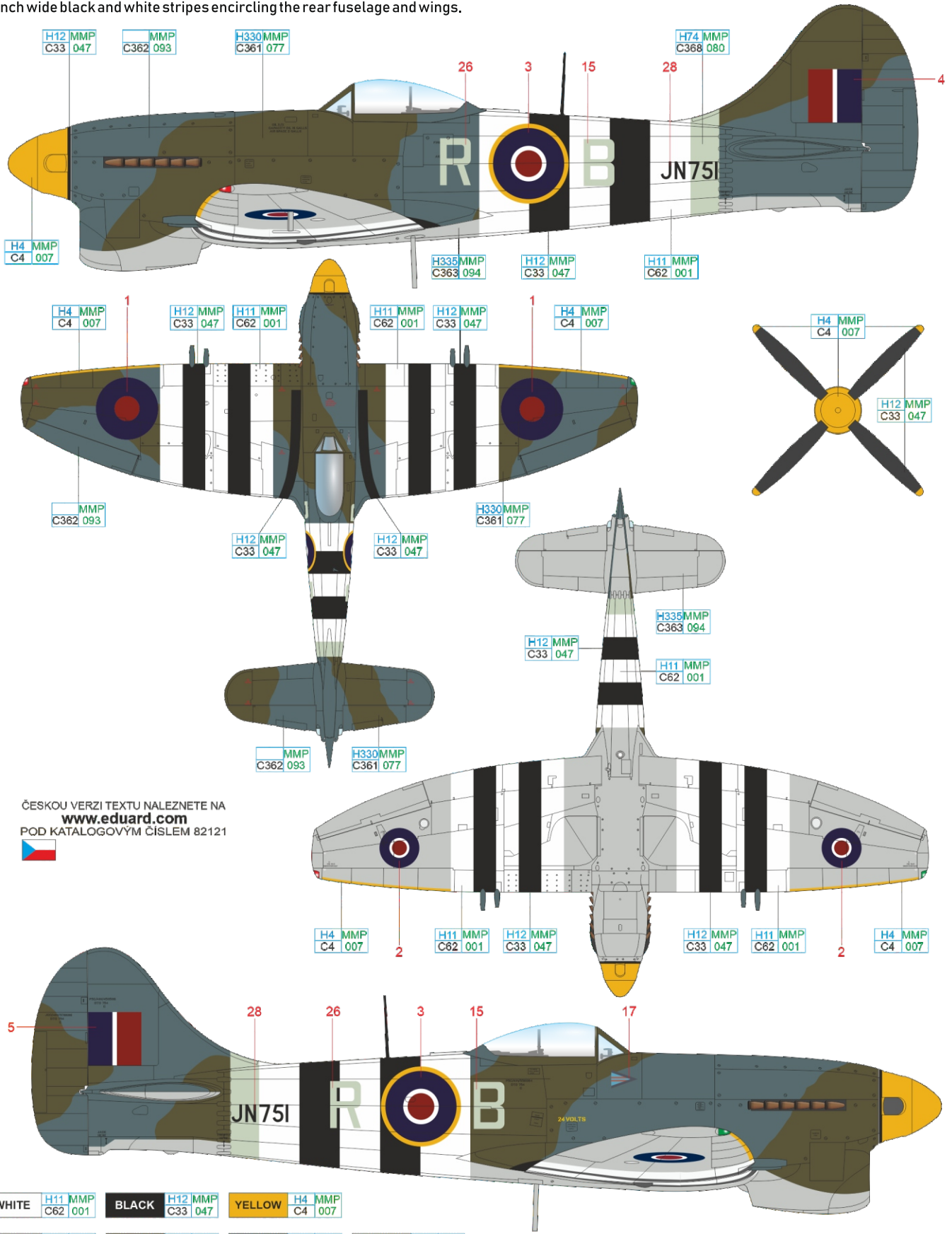

ČESKOU VERZI TEXTU NALEZNETE NA
www.eduard.com
 POD KATALOGOVÝM ČÍSLEM 82121

| | | | | | |
|-----------------|-------------------|------------|-------------------|------------|---------------|
| WHITE | H11 MMP C62 001 | BLACK | H12 MMP C33 047 | YELLOW | H4 MMP C4 007 |
| MEDIUM SEA GRAY | H335 MMP C363 094 | DARK GREEN | H330 MMP C361 077 | OCEAN GRAY | MMP C362 093 |
| | | SKY | H74 MMP C368 080 | | |

E JN763, No. 486 (RNZAF) Squadron, Newchurch, Great Britain, June 1944

No. 486 Squadron, a component of No. 150 Wing, was tasked with ground attack, but from mid-June 1944 to early September 1944, it was fully occupied with intercepting V-1 flying bombs launched from occupied Europe. The Squadron's pilots were credited with the destruction of 223,5 of them. After the threat of these attacks had decreased, No. 486 Squadron, along with its sister units, moved to liberated territory and up to the end of the war it was tasked with supporting advancing British units. The unit was disbanded on October 12, 1945 at RAF Dunsfold. On June 5, 1944, the squadron would receive aircraft, which were intended to support Operation Overlord (the invasion of Normandy) and received the invasion stripes on the rear fuselage and wings in the form of 18-inch wide black and white bands. These were applied in haste and could be quite inaccurate and scruffy. Photographic evidence shows stiffeners added to the rear section of the fuselage in form of fishplates (on this aircraft and all the other Tempests featured in this box).

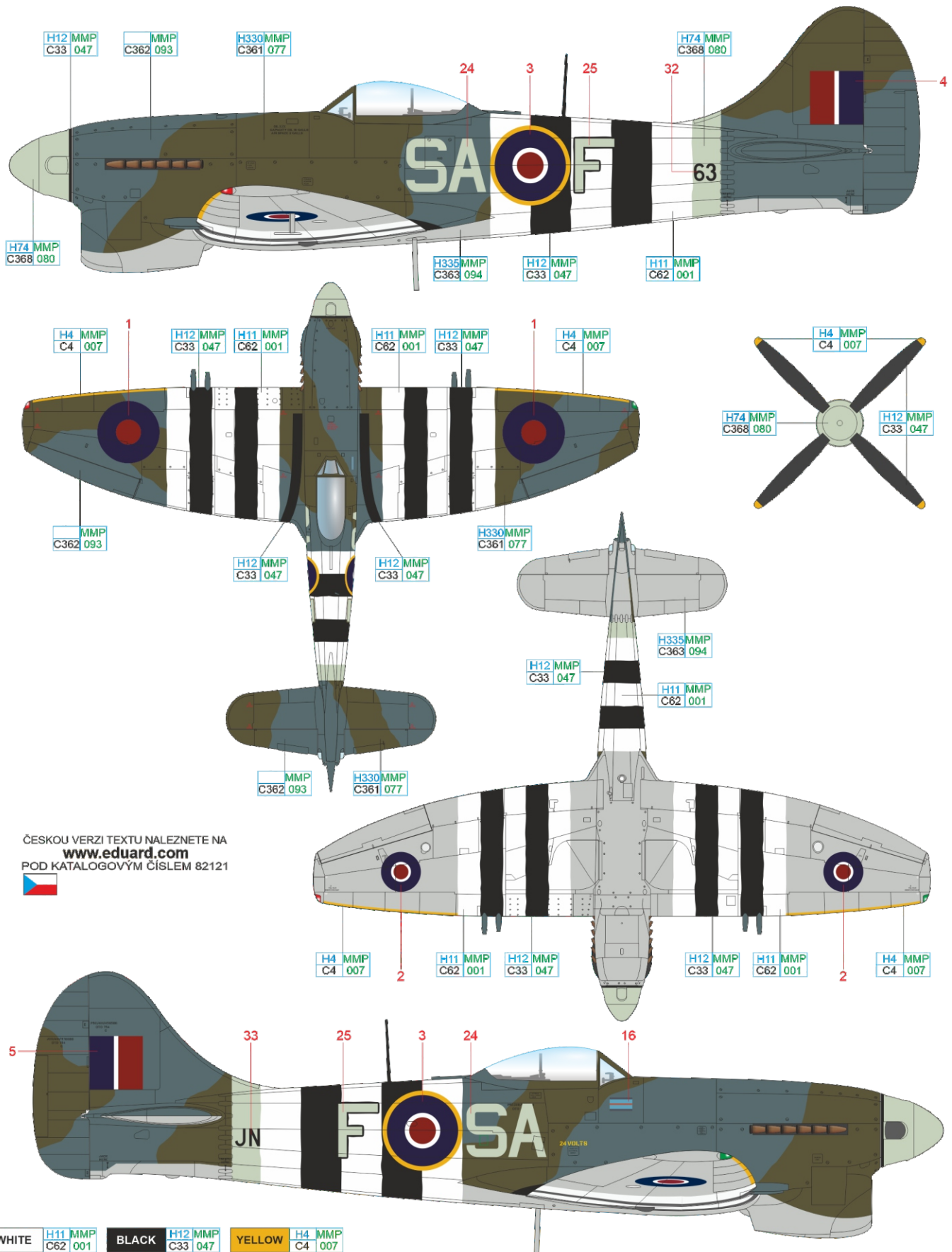

ČESKOU VERZI TEXTU NALEZNETE NA
www.eduard.com
 POD KATALOGOVÝM ČÍSLEM 82121



| | | | | | |
|--------------------|----------------------|---------------|----------------------|---------------|------------------|
| WHITE | H11 MMP C62 001 | BLACK | H12 MMP C33 047 | YELLOW | H4 MMP C4 007 |
| MEDIUM SEA GRAY | H335 MMP C363 094 | DARK GREEN | H330 MMP C361 077 | OCEAN GRAY | MMP C362 093 |
| | | SKY | H74 MMP C368 080 | | |

F JN765, No. 3 Squadron, Newchurch, Great Britain, June 1944

In early June 1944, No. 3 Squadron's code was changed from Q0 to JF which was used until August 1945. The so-called "Invasion Stripes" were also added to JN765 aircraft prior to the operation. Groundcrew painted the bottom section of the main landing gear cover black, apparently in error.

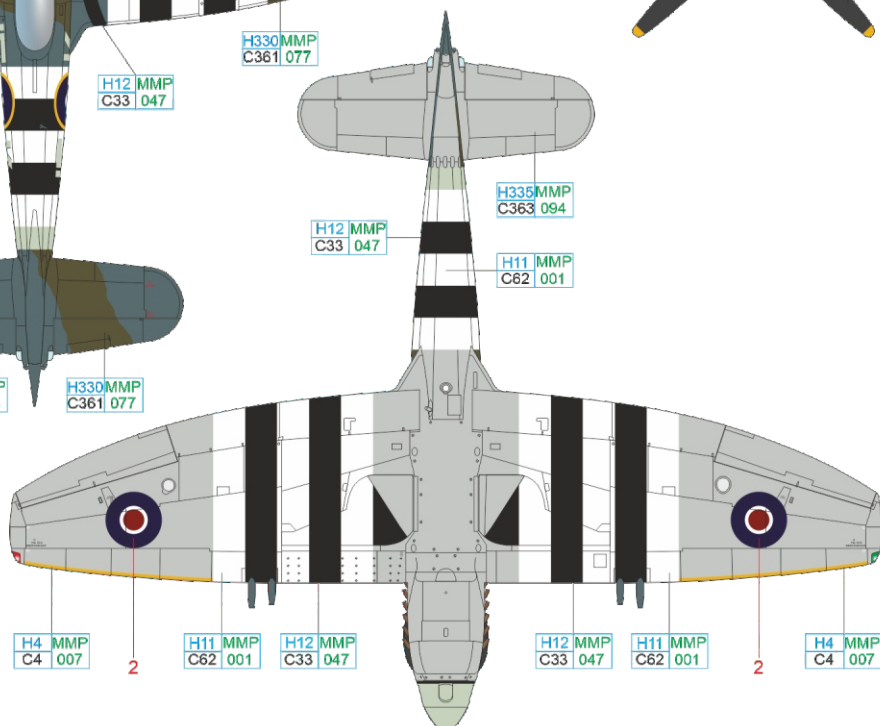
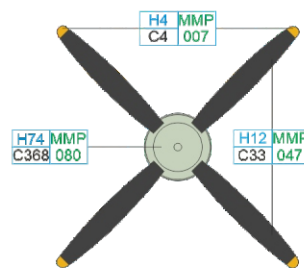
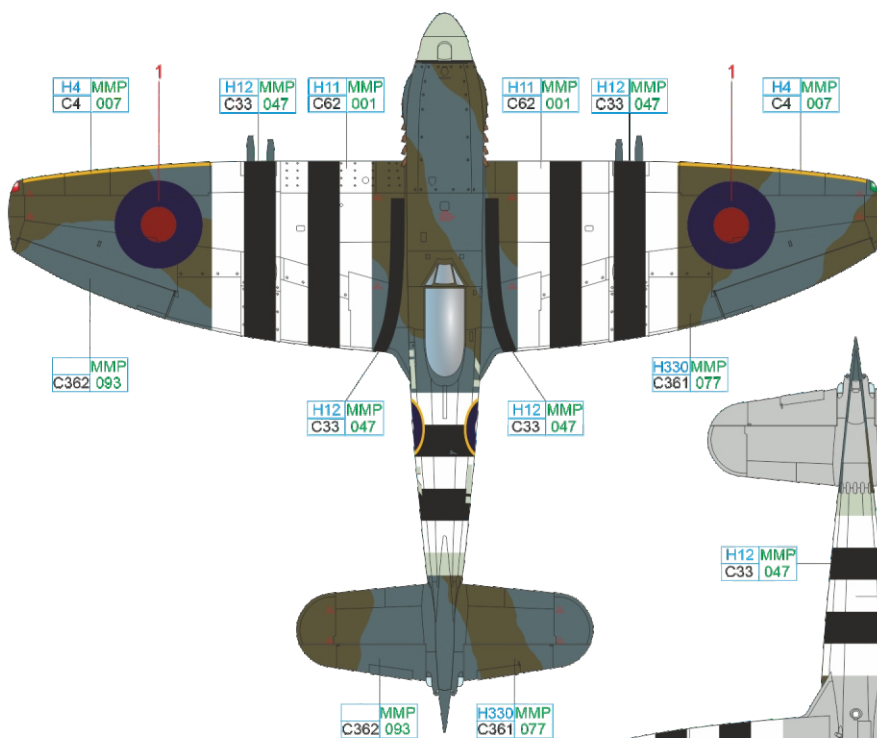
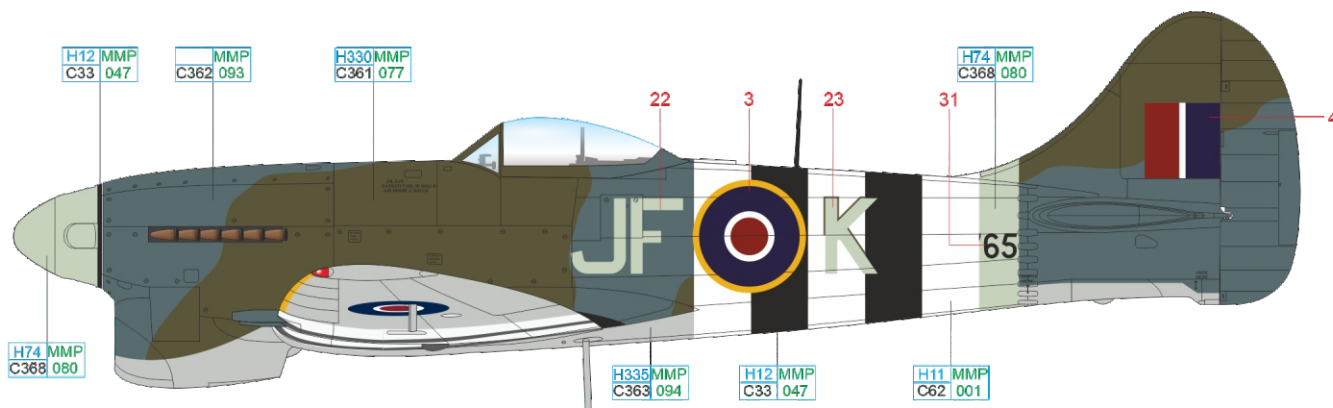

ČESKOU VERZI TEXTU NALEZNETE NA
www.eduard.com
POD KATALOGOVÝM ČÍSLEM 82121

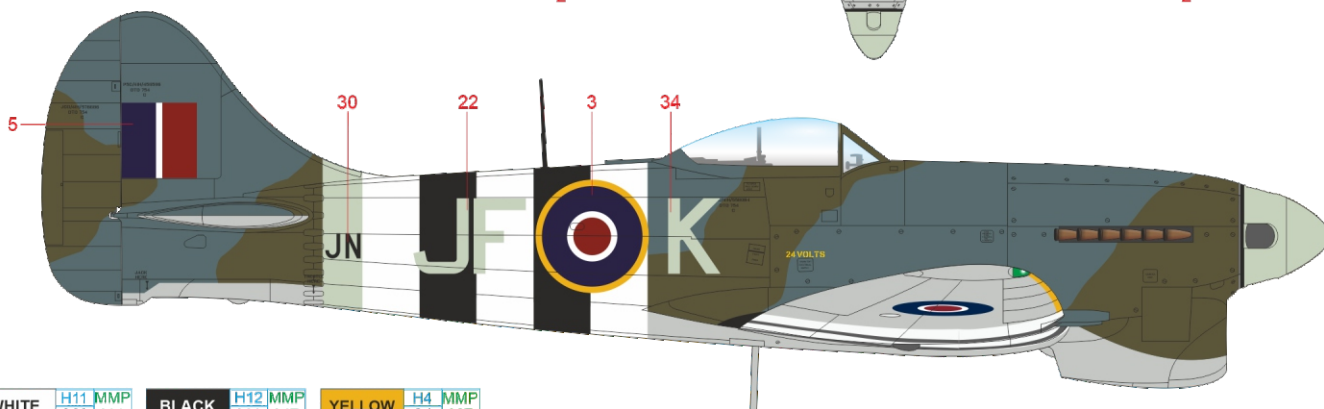

| | | | | | |
|-----------------|----------------------|------------|----------------------|------------|------------------|
| WHITE | H11 MMP C62 001 | BLACK | H12 MMP C33 047 | YELLOW | H4 MMP C4 007 |
| MEDIUM SEA GRAY | H335 MMP C363 094 | DARK GREEN | H330 MMP C361 077 | OCEAN GRAY | MMP C362 093 |
| | | SKY | H74 MMP C368 080 | | |

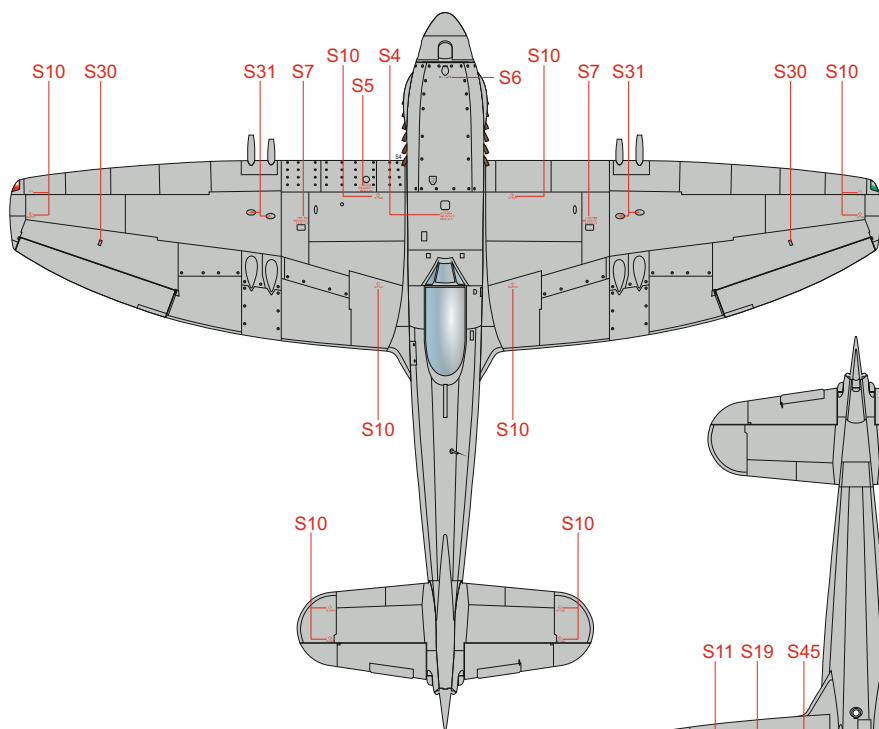
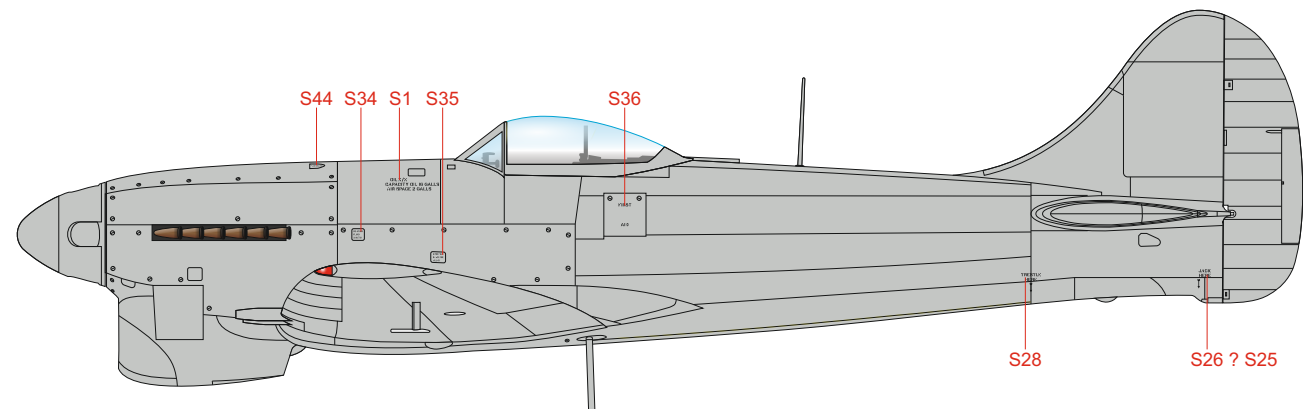

S47 - ALL „AMAL”
FASTENERS
ON THE WINGS AND
FUSELAGE

