

Tempest Mk.II late version

eduard

1/48 Scale Plastic Model Kit

ProfiPACK
edition



item No. 82125

The piston engine aircraft development peaked at the end of World War II, pushing some remarkable designs into service. The Hawker Tempest was one of them. This high performing beast reached its full potential with radial engine power.

The story of the Tempest originated in an attempt to address the shortcomings that prevented its predecessor, the Hawker Typhoon succeeding as a fighter. The main design problem with the Typhoon was the thick wing with NACA 22 profile, offering lot of inner space for fuel and armament, but building drag rapidly with rising speed. Not surprisingly the wing was at the core of the changes in the development of the new fighter. The resulting design was originally supposed to retain the Typhoon name as the Mark II, but it was changed to Tempest finally. The new wing was 5 in (12,7 cm) thinner at the root and the planform changed in comparison with Typhoon wing to a near elliptical shape. As the new wing did not offer enough space for fuel, additional fuel tank of 76-gallon (288 l) volume had to be installed in the fuselage. The space was created between the firewall and the oil tank by moving the engine forward by 21 in (53,4 cm). Owing to that, the horizontal tail surfaces had to be enlarged. The Typhoon main undercarriage was replaced by a levered-leg Dowty design.

Sabre first

An initial contract was placed for two prototypes based on the Typhoon airframes powered by Sabre IV engine, but, due to delays in the development of the latter, it was only installed in HM599, while HM595 used the older Sabre II. Concerns over the Sabre's future led to the consideration of other engines but there were only two other units powerful enough for use with the Tempest: The RR Griffon and radial Bristol Centaurus. The prototype order was increased to six – two with each engine type. Different marks were assigned to each engine variant. The Mk.I was to be powered by the Sabre IV (HM599), the Mk.II by the Centaurus IV (LA602 and LA607), the Mk.III by the R&R Griffon IIB (LA610) and the Mk.IV by the Griffon 61 (LA614). Finally, the Mk.V (HM595) used a slightly improved version of the Sabre II (IIB) producing 2,400 hp (1,790 kW), thus 200 hp (147 kW) more than previous version. However, the Mk.V with the Sabre IIB was only intended as a stopgap solution until Sabre IV engines would be available; it would finally emerge as the main mark of the Tempest. The Mk. I, III and IV were not put into production, leaving the Mk.II as the „ultimate Tempest“ (although it would later be joined by the Mk.VI, powered by a developed Sabre engine). The HM595 prototype with Sabre II flew for the first time on September 2, 1942. The first production Tempest Mk.V made its maiden flight on June 21, 1943, already fitted with bubble canopy. Armed with four 20mm Hispano Mk.II cannon (200 rounds per gun) it achieved a top speed of 432 mph (695 km/h) at 18,400 feet (5,600 m), up to 45 mph (72 km/h) more than Bf 109 or Fw 190 (depending on mark).

Radial power

The radial-powered prototype of Tempest Mk.II, LA602, made its maiden flight on June 28, 1943, just seven days after the first production Mk.V. This prototype was powered by Bristol Centaurus IV developing 2,520 hp (1,879 kW) but still had problems to resolve. The increase of power over the Napier Sabre was quite significant and allowed for better over-

all performance, as the weight remained roughly the same. One of the most evident problems, excessive vibration, was solved by changing original rigid eight-point engine mounts for rubber-packed six-point mounts. As there were several other shortcomings, the start of the production was delayed, although the first order had been placed as early as in September 1942, calling for 500 Mk.IIs to be built by Gloster company. Later it was changed for 330 Mk.IIs built by Bristol and 1,800 by Hawker and these logistical changes caused yet more delay. The first production Mk.II came off production line on October 4, 1944, only to serve for trials alongside next six production aircraft.

Limited combat action

With the end of the war in Europe in sight, the orders for the Tempest Mk.II were cancelled or substantially reduced. Deployment to the Far East was postponed following the Japanese surrender and so the Tempest Mk.II did not see any wartime action. Only 50 of them were produced by the Bristol facility at Banwell, while Hawker added 402 aircraft. From 452 produced 180 were sent to India between 1945 and 1947. Some of them were to serve with four RAF squadrons (Nos. 5; 20; 30 and 152) based there, others with RIAF (Royal Indian Air Force) squadrons. When India and Pakistan achieved independence in 1947 the RAF squadrons were disbanded and their Mk.IIs were divided between the two countries. Both later purchased more Tempests from Hawker and from surplus RAF stocks and the type would see use in the fighting over Hyderabad, Kashmir and Jammu states in 1947-49.

In Europe, the Tempest Mk.II saw post-war service with two Fighter Command squadrons, as well as with three BAFo (British Air Forces of Occupation) squadrons in Germany. All these would be re-equipped with Vampire jets by 1949, except for No. 33 Sqn whose Mk.IIs would see combat use in 1949-51 during RAF operations against the communist guerillas in Malaya.

This kit: Tempest Mk.II late version

Although some sources distinguish between the fighter-bomber and fighter versions of Tempest Mk.II, it was the same aircraft with provisions for the wing racks to carry rockets or bombs; attachment points for drop tanks were also incorporated in the structure of the wing. The Mk.IIs were basically produced in two batches, with the first one split between two facilities. The Banwell Bristol factory made 50 of them, while the Langley Hawker factory added 100. These aircraft were given serials with MW prefix and were finished without the tropical filter, recognizable by the louvred panel in front of the windshield. They also lacked the water cylinders in the cockpit. Both features were typical for the late series (serials with PR prefix) produced in seven batches (302 were manufactured). Many Tempests Mk.II of MW series were later converted to the full tropical standard and sold to Pakistan and India. The latest RAF Tempests in combat were those of the No. 33 Sqn, deployed in Malaysia during the Malayan Emergency. They were used during 1950 and 1951.

ATTENTION



UPOZORNĚNÍ



ACHTUNG



ATTENTION



注意



Carefully read instruction sheet before assembling. When you use glue or paint, do not use near open flame and use in well ventilated room. Keep out of reach of small children. Children must not be allowed to suck any part, or pull vinyl bag over the head.



Před započítím stavby si pečlivě prostudujte stavební návod. Při používání barev a lepidel pracujte v dobře větrané místnosti. Lepidla ani barvy nepoužívejte v blízkosti otevřeného ohně. Model není určen malým dětem, mohlo by dojít k požití drobných dílů.

INSTRUCTION SIGNS * INSTR. SYMBOLS * INSTRUKTION SINNBILDEN * SYMBOLES * 記号の説明

OPTIONAL
VOLBABEND
OHNOUTSAND
BROUSITOPEN HOLE
VYVRTAT OTVORSYMETRICAL ASSEMBLY
SYMETRICKÁ MONTÁŽREMOVE
ODŘÍZNOUTREVERSE SIDE
OTOČITAPPLY EDUARD MASK
AND PAINT
POUŽIT EDUARD MASK
NABARVIT

PARTS



DÍLY



TEILE



PIÈCES



部品

PLASTIC PARTS

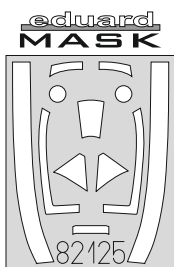
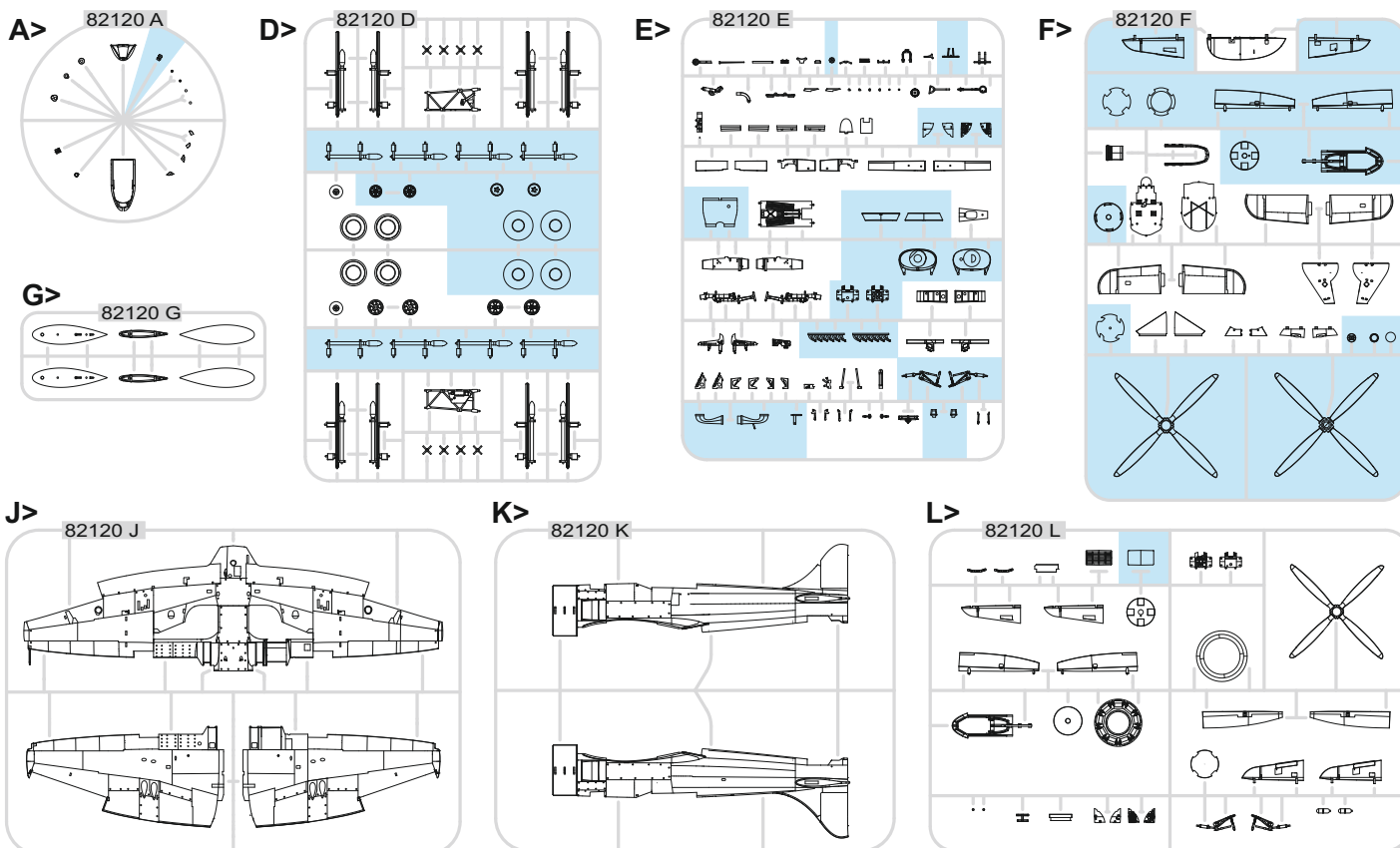

PE - PHOTO ETCHED DETAIL PARTS

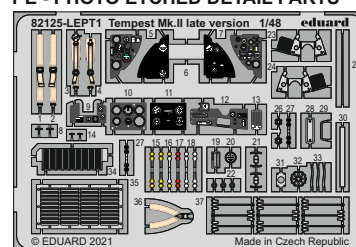

-Parts not for use. -Teile werden nicht verwendet. -Pièces à ne pas utiliser. -Tyto díly nepoužívejte při stavbě. - 使用しない部品

COLOURS



BARVY



FARBEN



PEINTURE



色

GSI Creos (GUNZE)		MISSION MODELS	
AQUEOUS	Mr.COLOR	PAINTS	
H4	C4	MMP-007	YELLOW
H7	C47	MMP-002	BROWN
H8	C8		SILVER
H11	C62	MMP-001	FLAT WHITE
H12	C33	MMP-047	FLAT BLACK
H15	C66		BRIGHT BLUE
H52	C12	MMP-091	OLIVE DRAB
H71	C21	MMP-076	MIDDLE STONE
H72	C369	MMP-078	DARK EARTH
H74	C368	MMP-080	SKY
H77	C137	MMP-040	TIRE BLACK
H90	C47		CLEAR RED

GSI Creos (GUNZE)		MISSION MODELS	
AQUEOUS	Mr.COLOR	PAINTS	
H94	C138		CLEAR GREEN
H307	C307	MMP-074	GRAY
H330	C361	MMP-077	DARK GREEN
H335	C363	MMP-094	MEDIUM SEAGRAY
	C362		OCEAN GRAY
	C364	MMP-079	AIRCRAFT GRAY-GREEN
	C370	MMP-092	AZURE BLUE
Mr.METAL COLOR		METALLICS	
MC214		MMM-001	DARK IRON
MC218		MMM-003	ALUMINIUM
Mr.COLOR SUPER METALLIC		METALLICS	
SM201		MMC-001	SUPER FINE SILVER

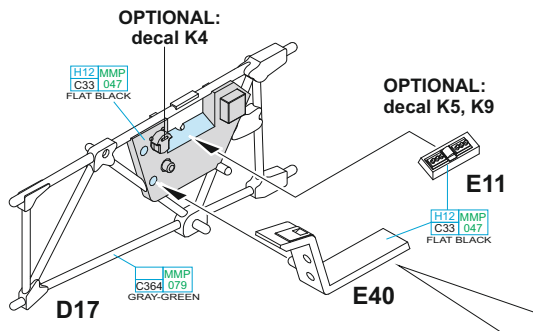
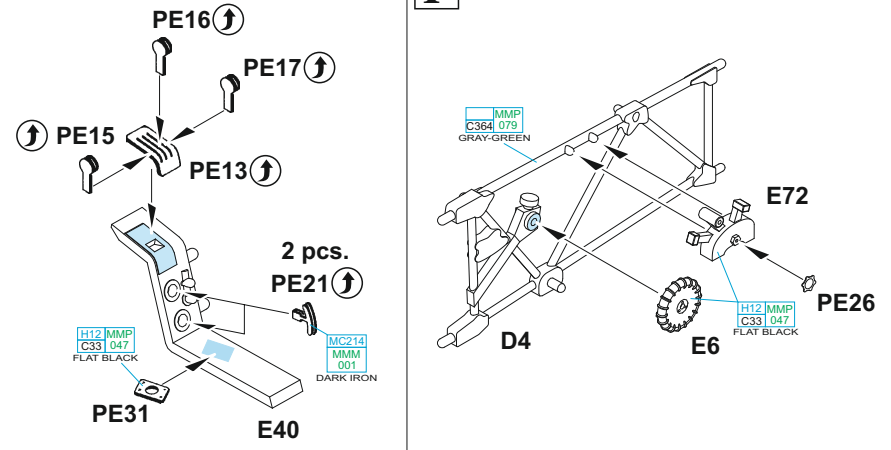
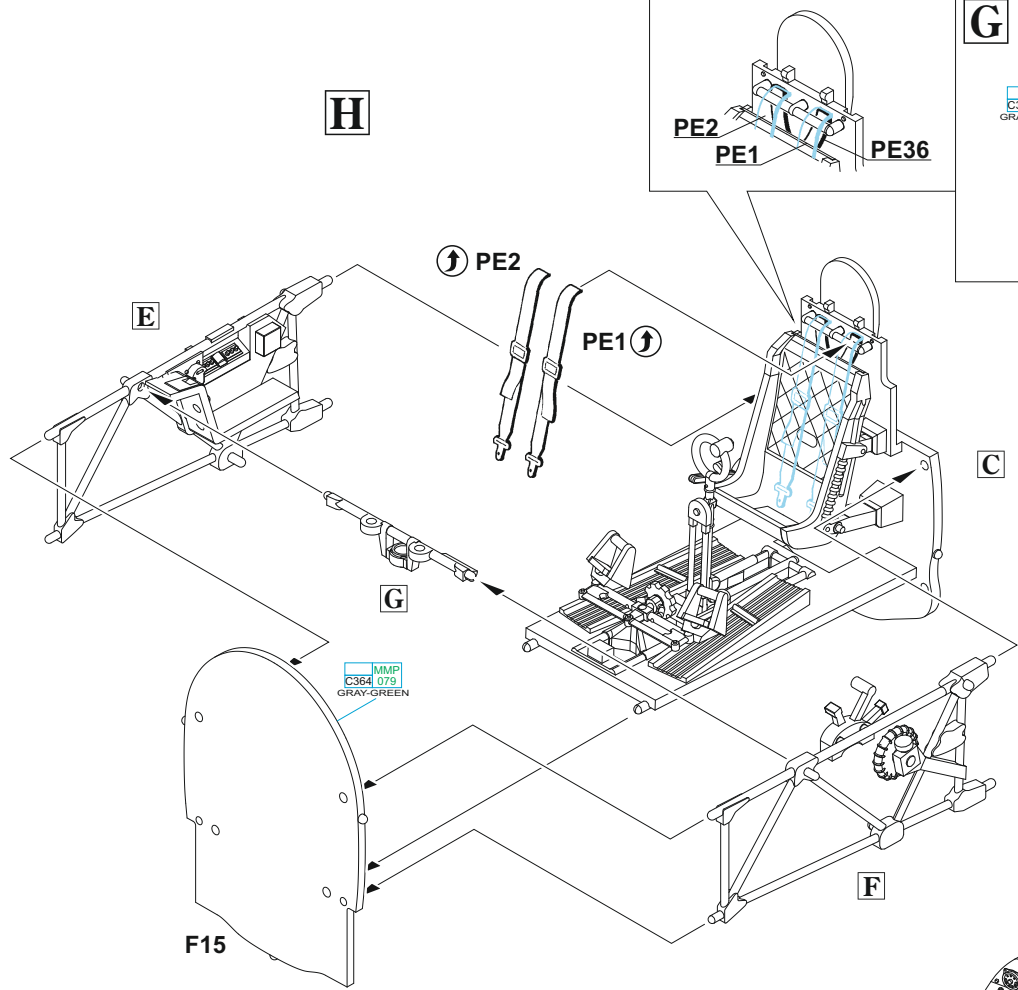
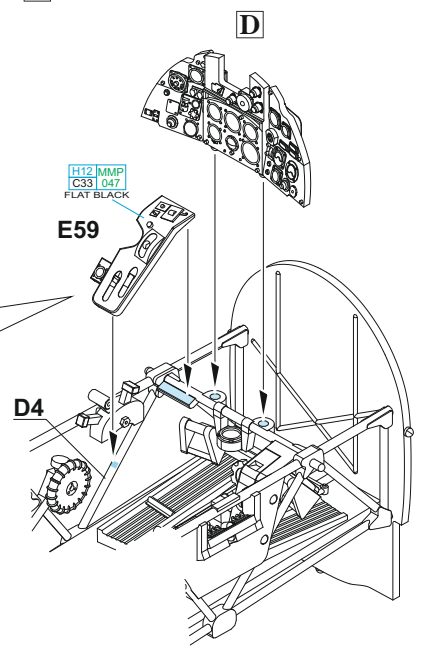
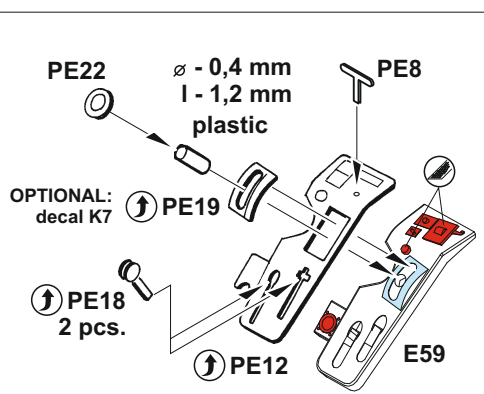
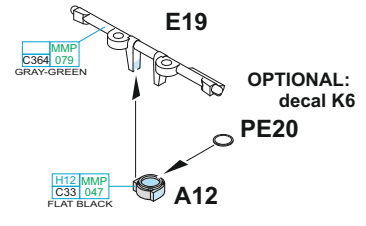
E**F****H****G**

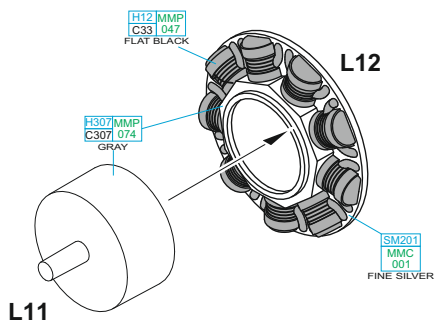
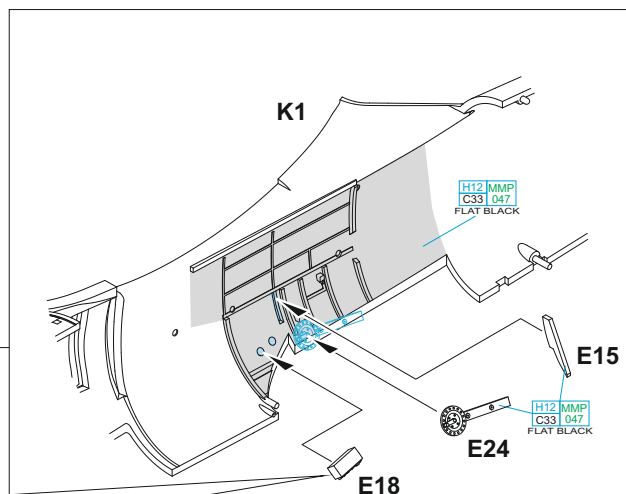
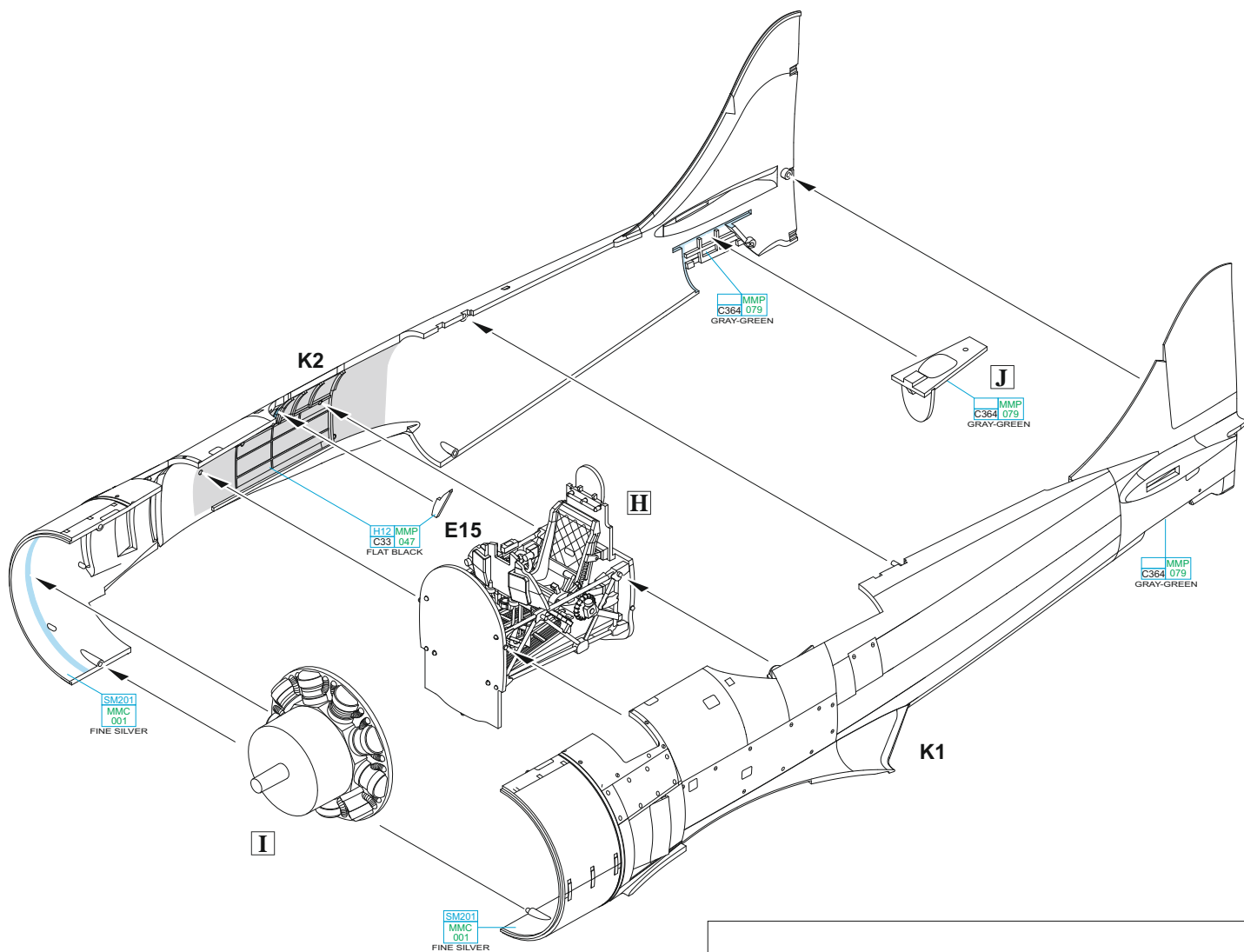
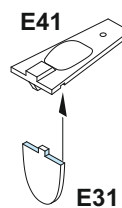
I**J**

OPTIONAL:
decal K8

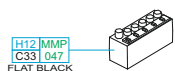
**E18**

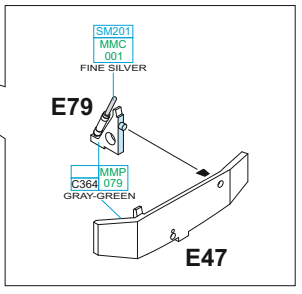
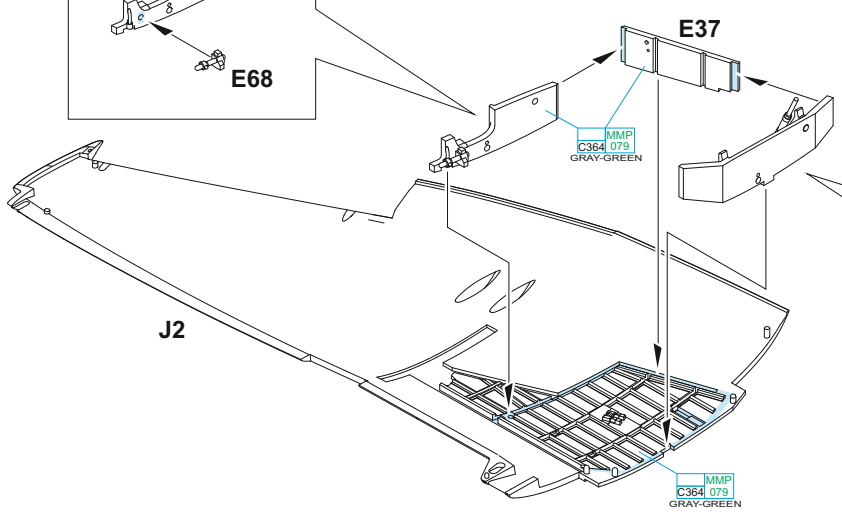
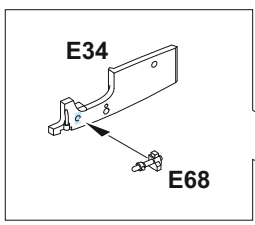
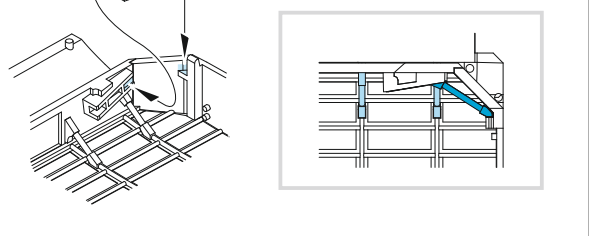
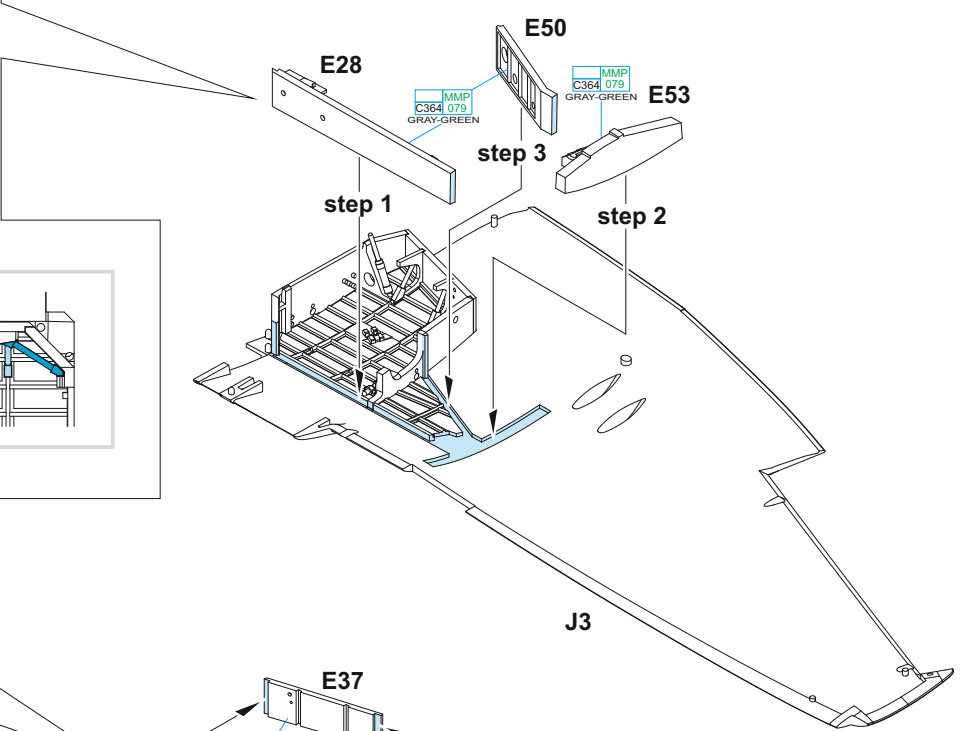
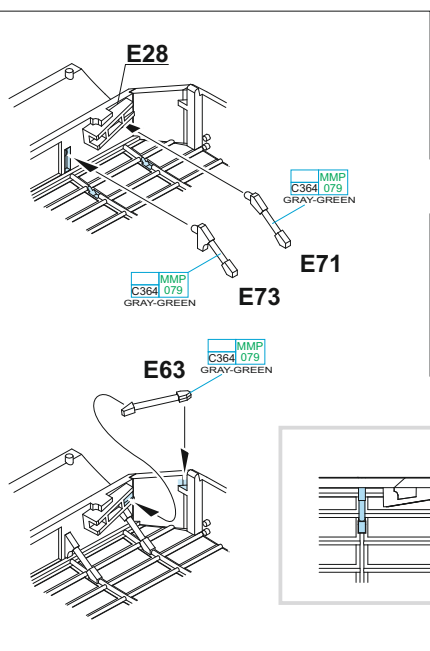
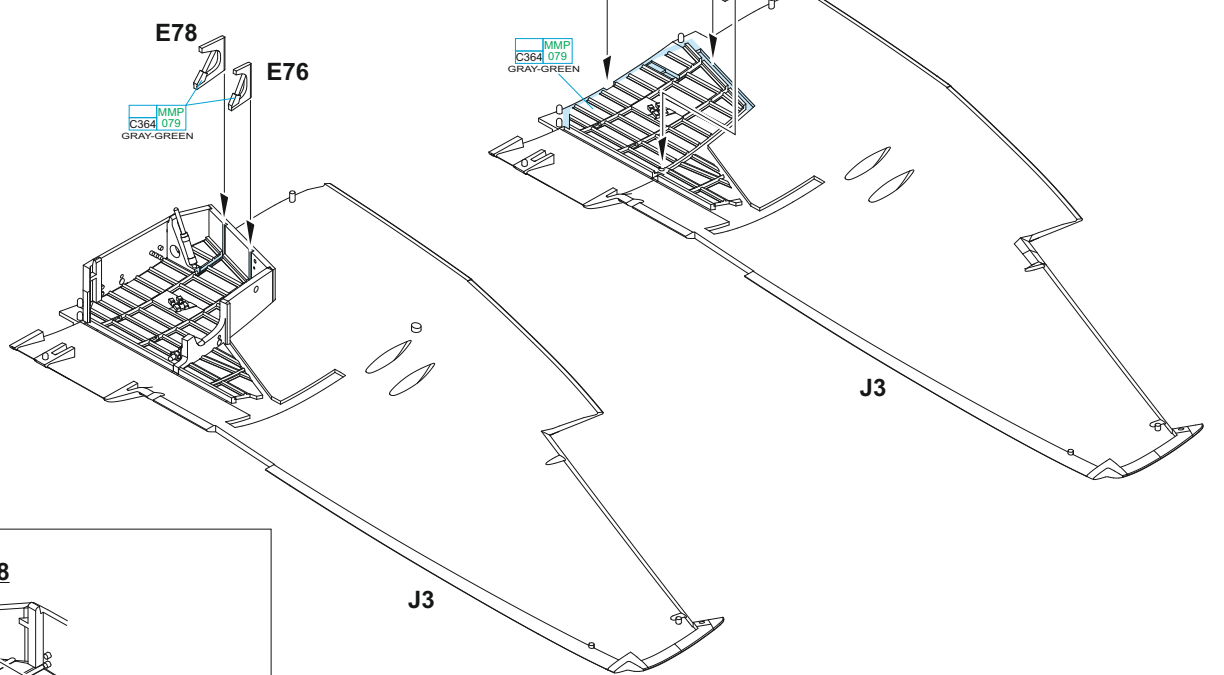
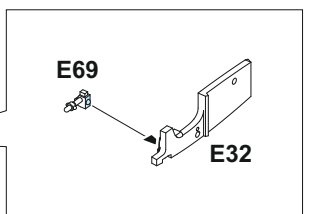
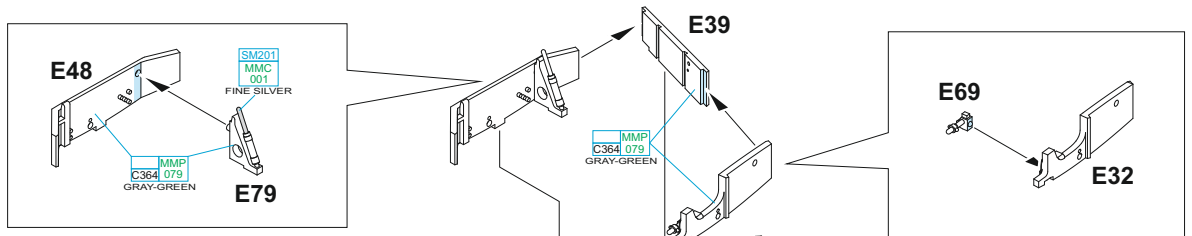

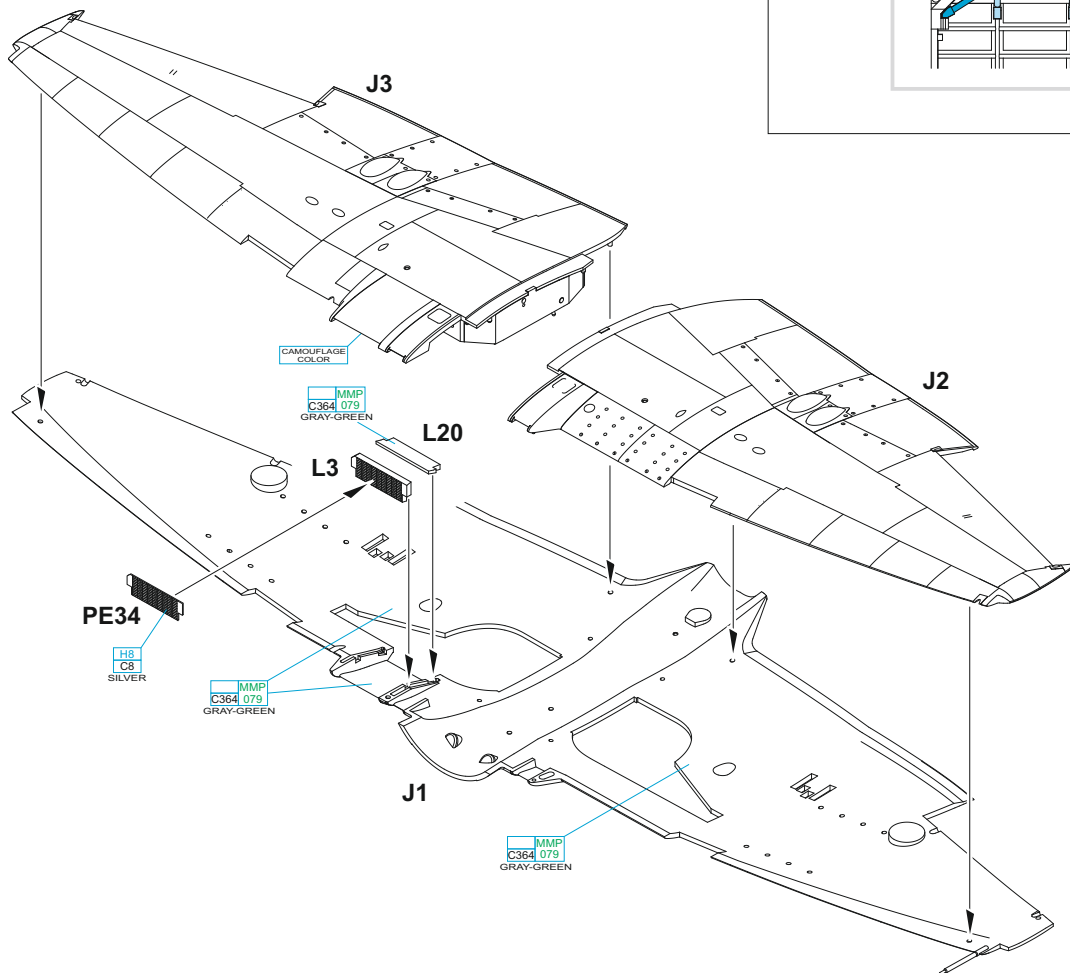
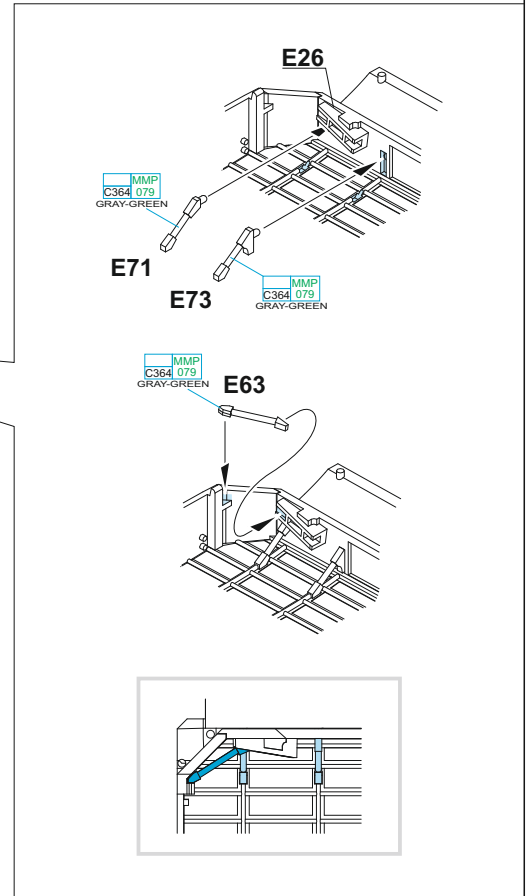
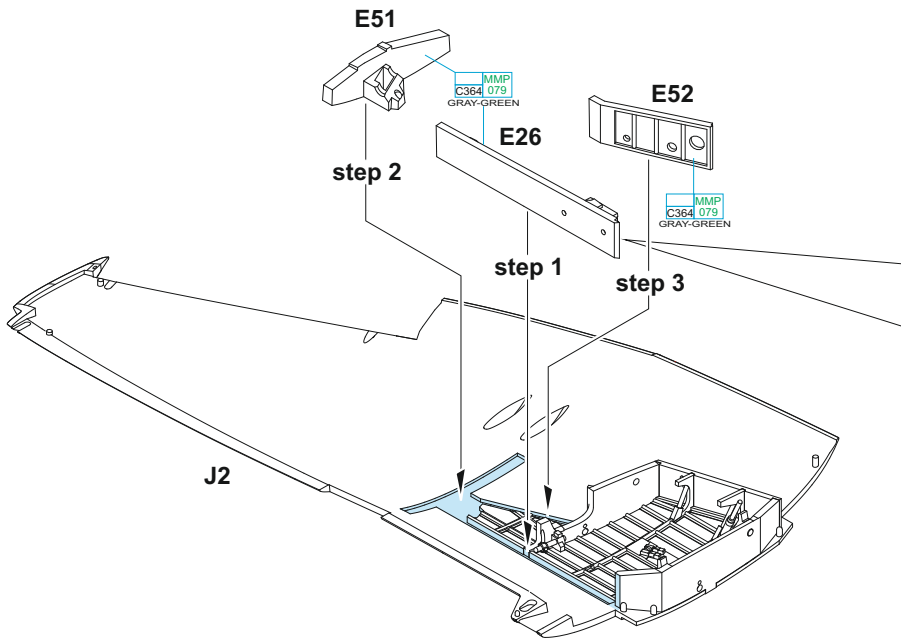
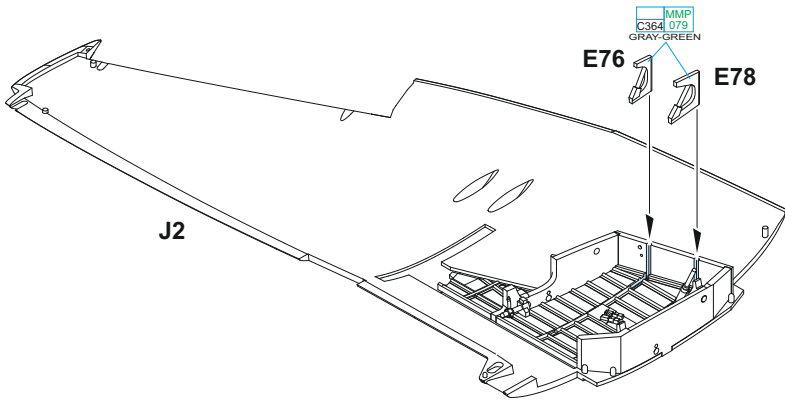

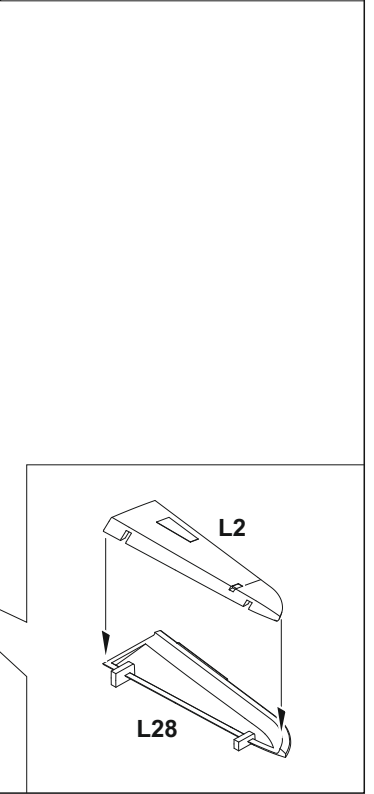
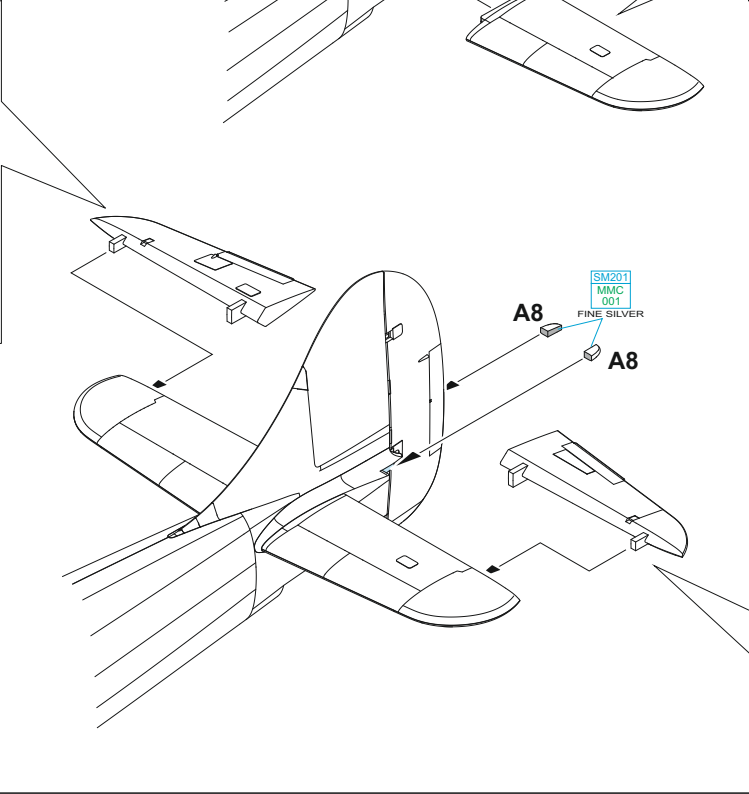
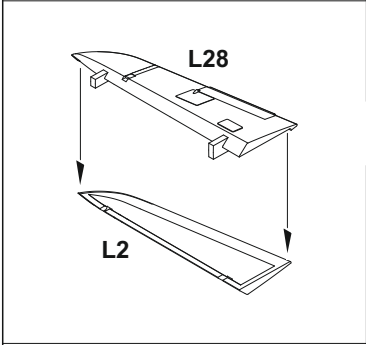
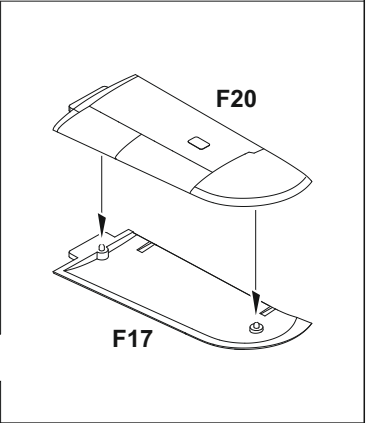
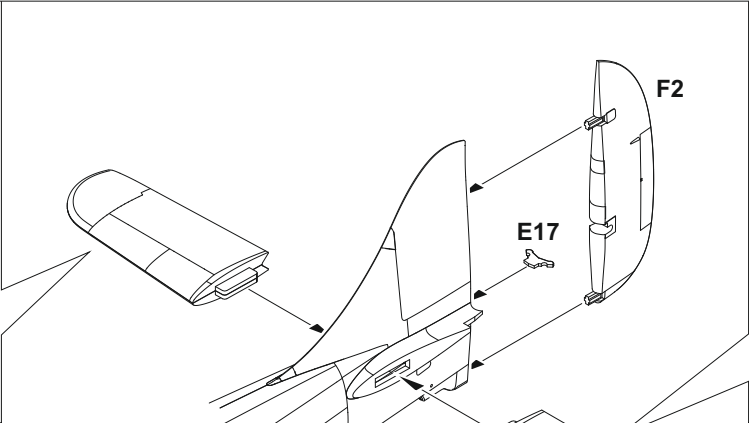
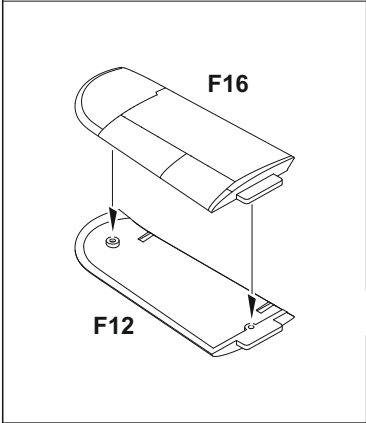
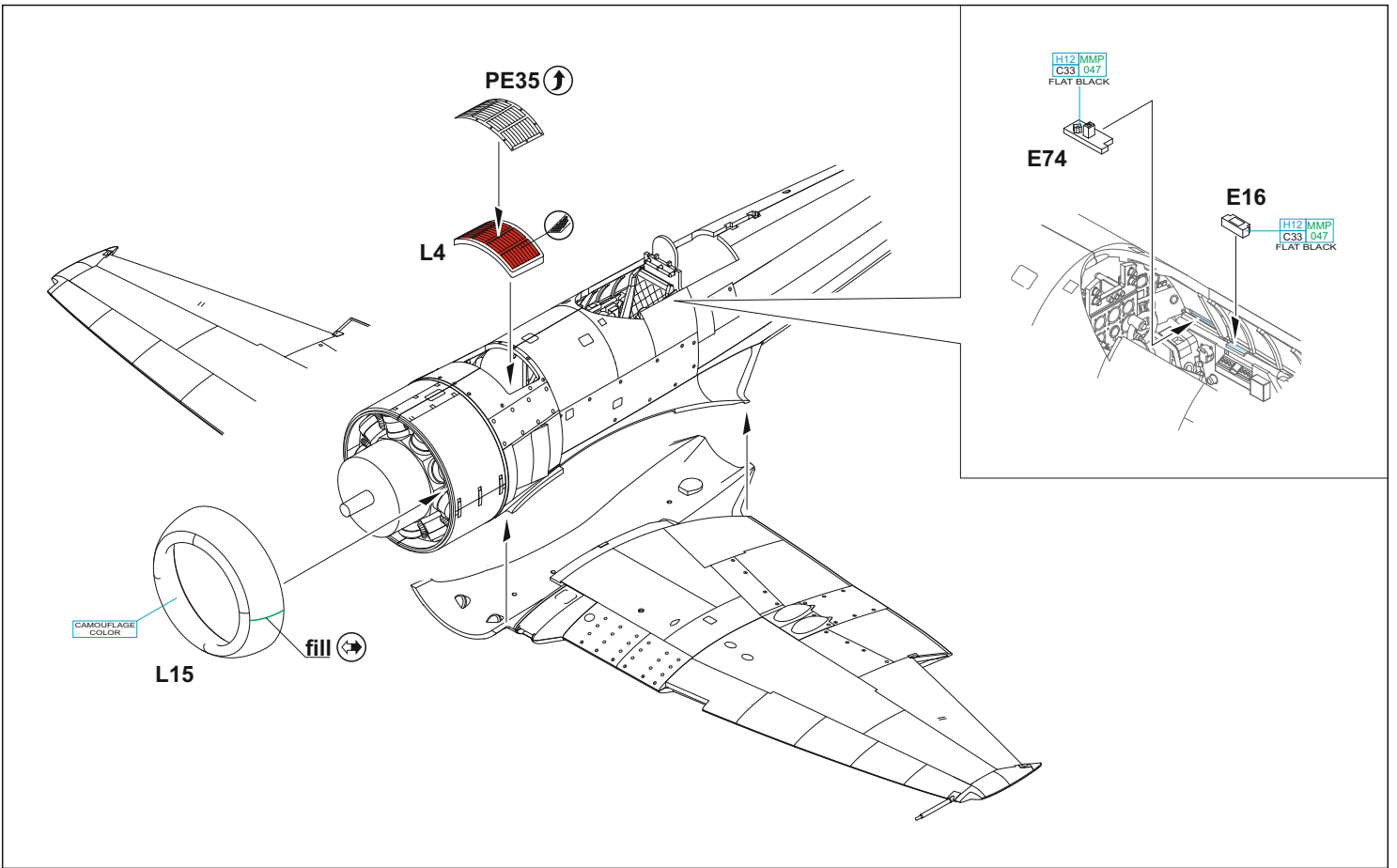

K

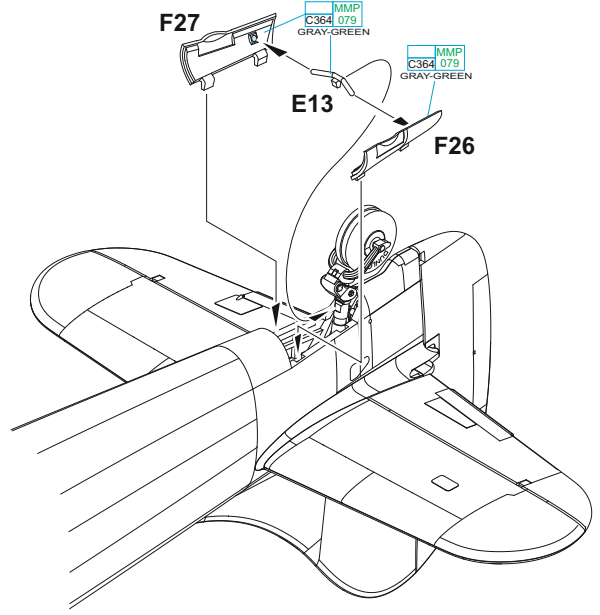
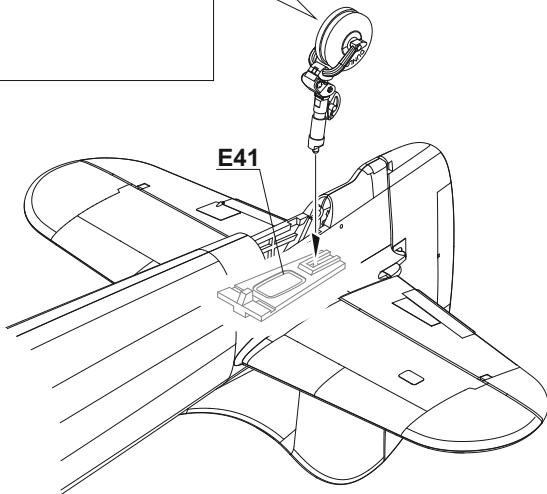
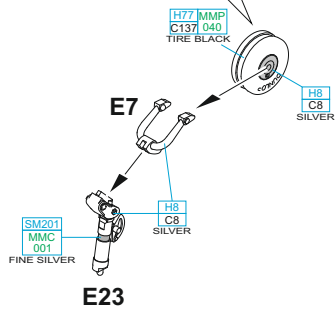
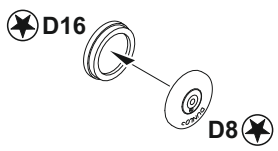
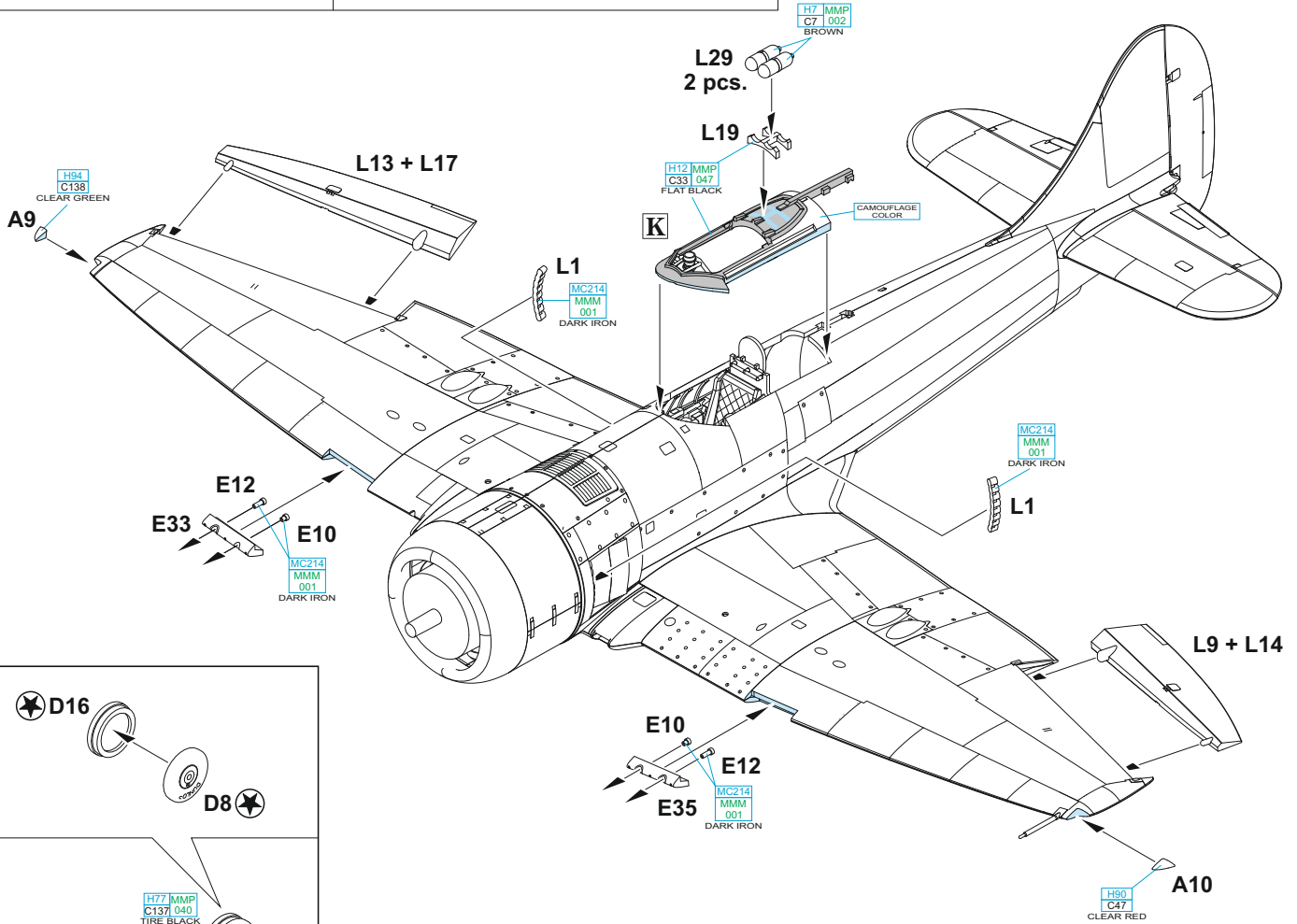
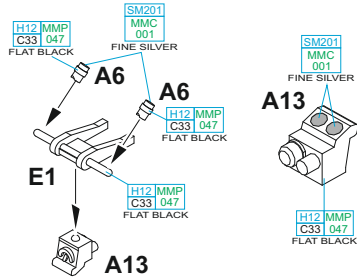
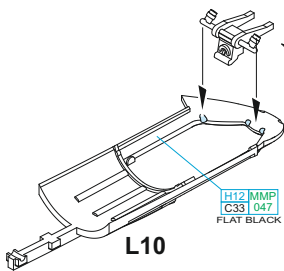

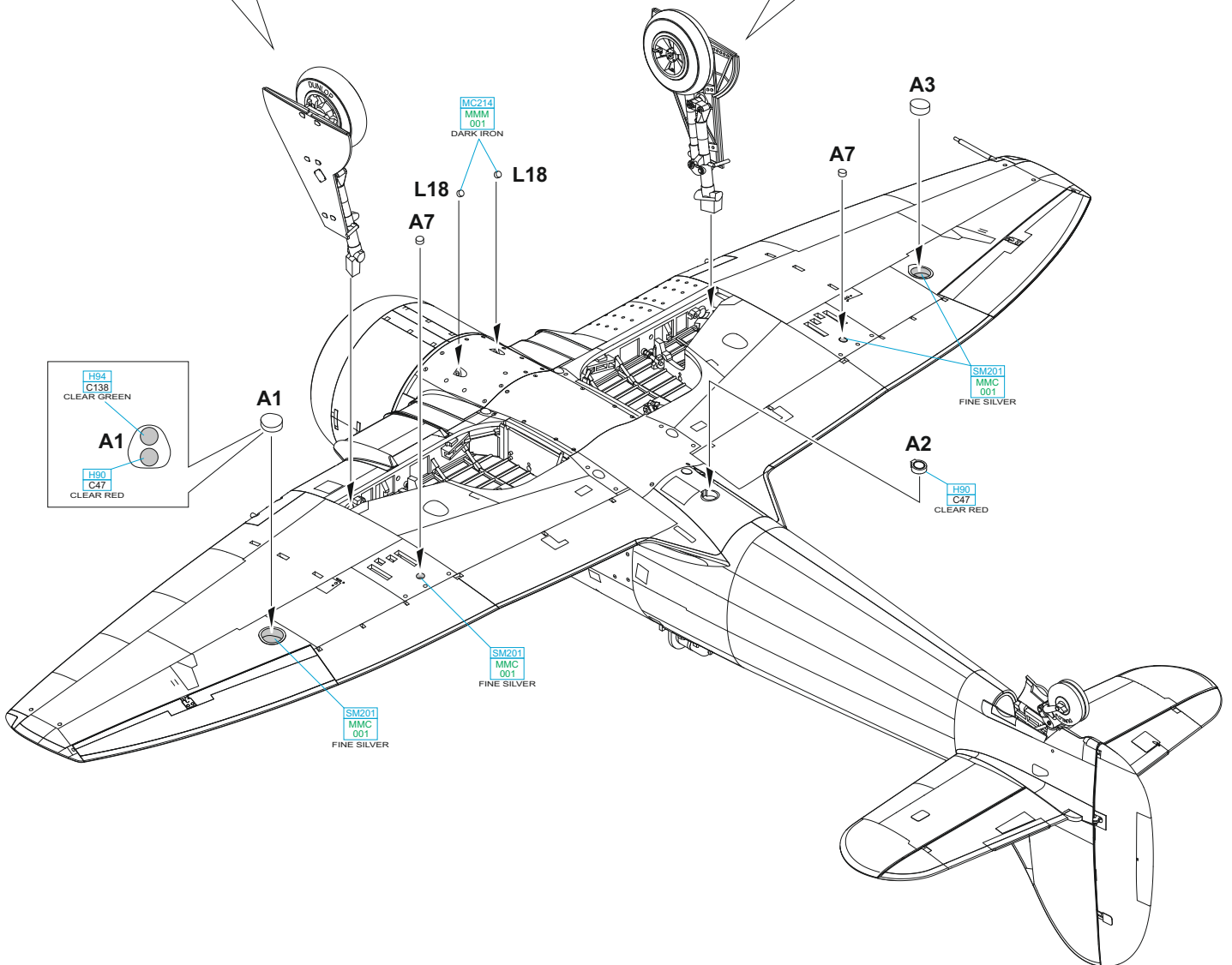
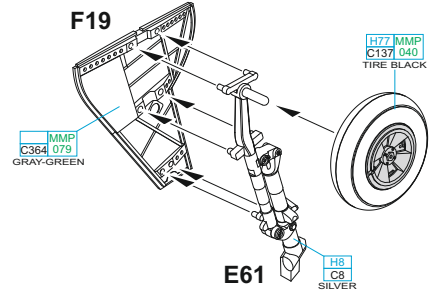
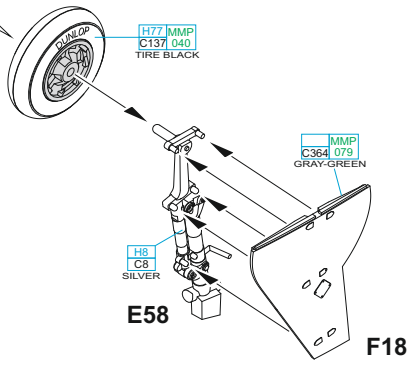
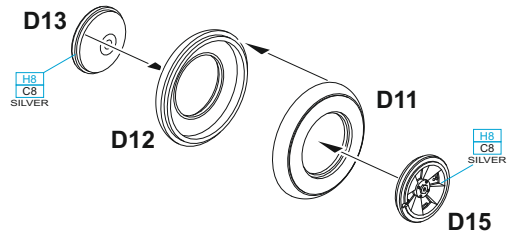
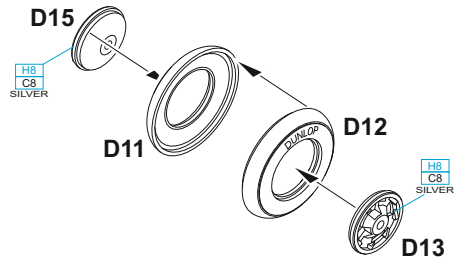

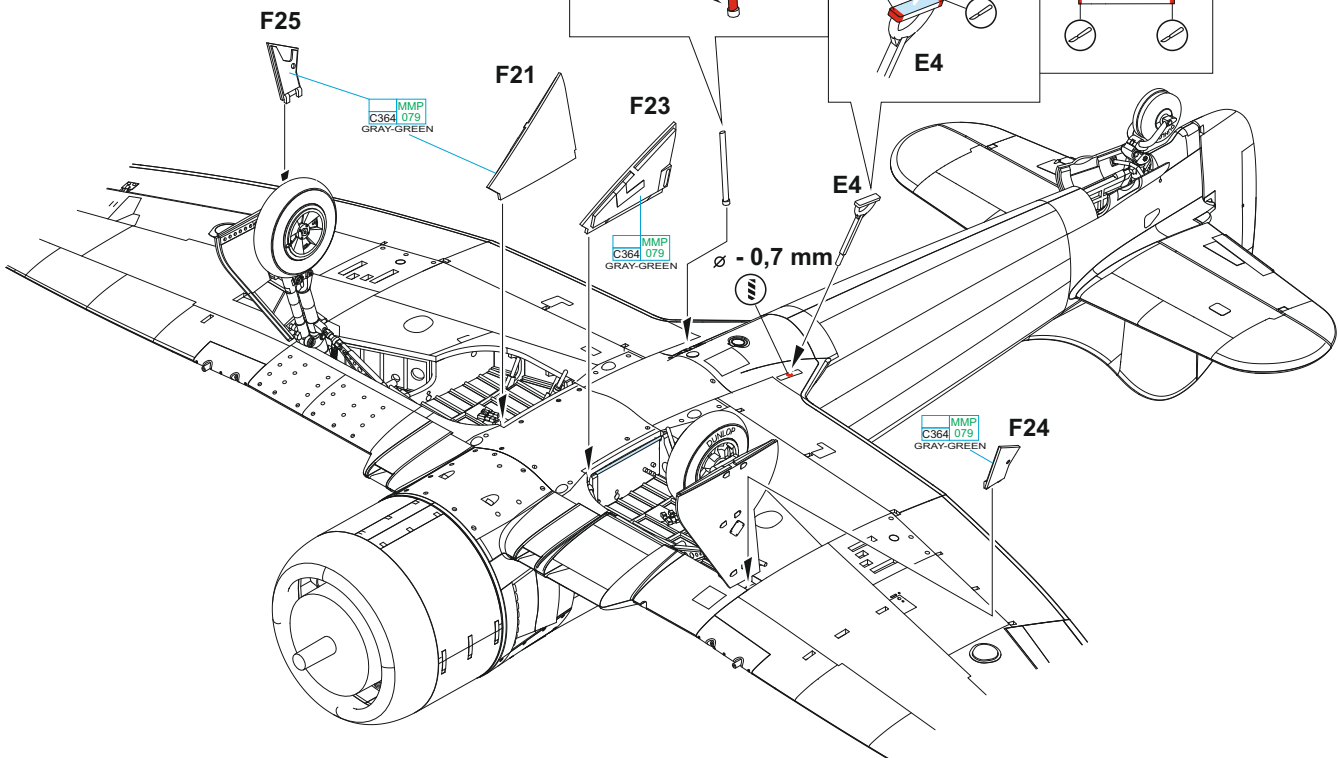
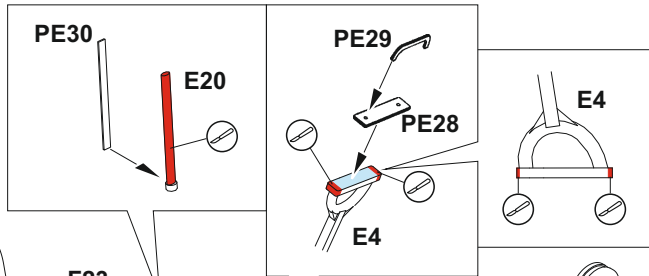
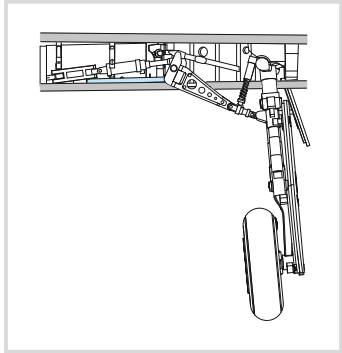
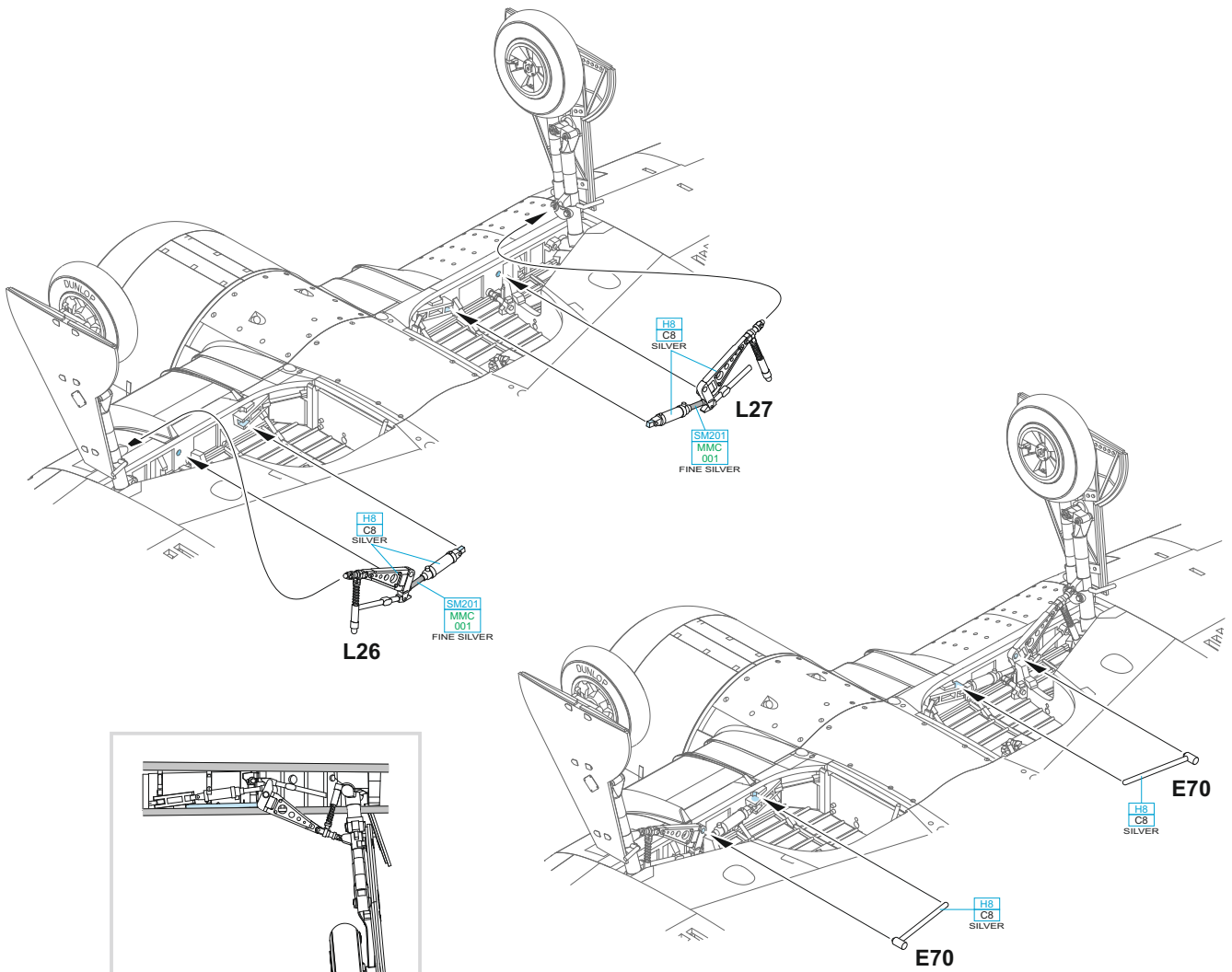

L

H12 MMP
C33 047
FLAT BLACK

F11

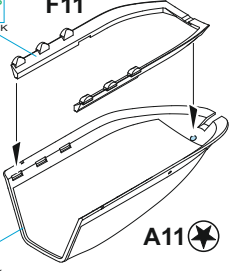

A11

PE25

E22

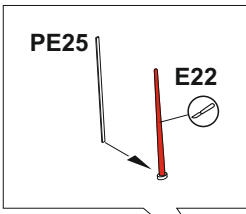

CLOSED CANOPY

L

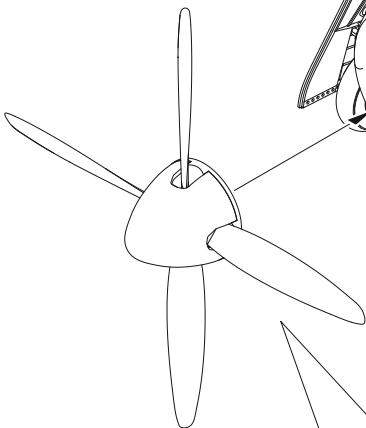
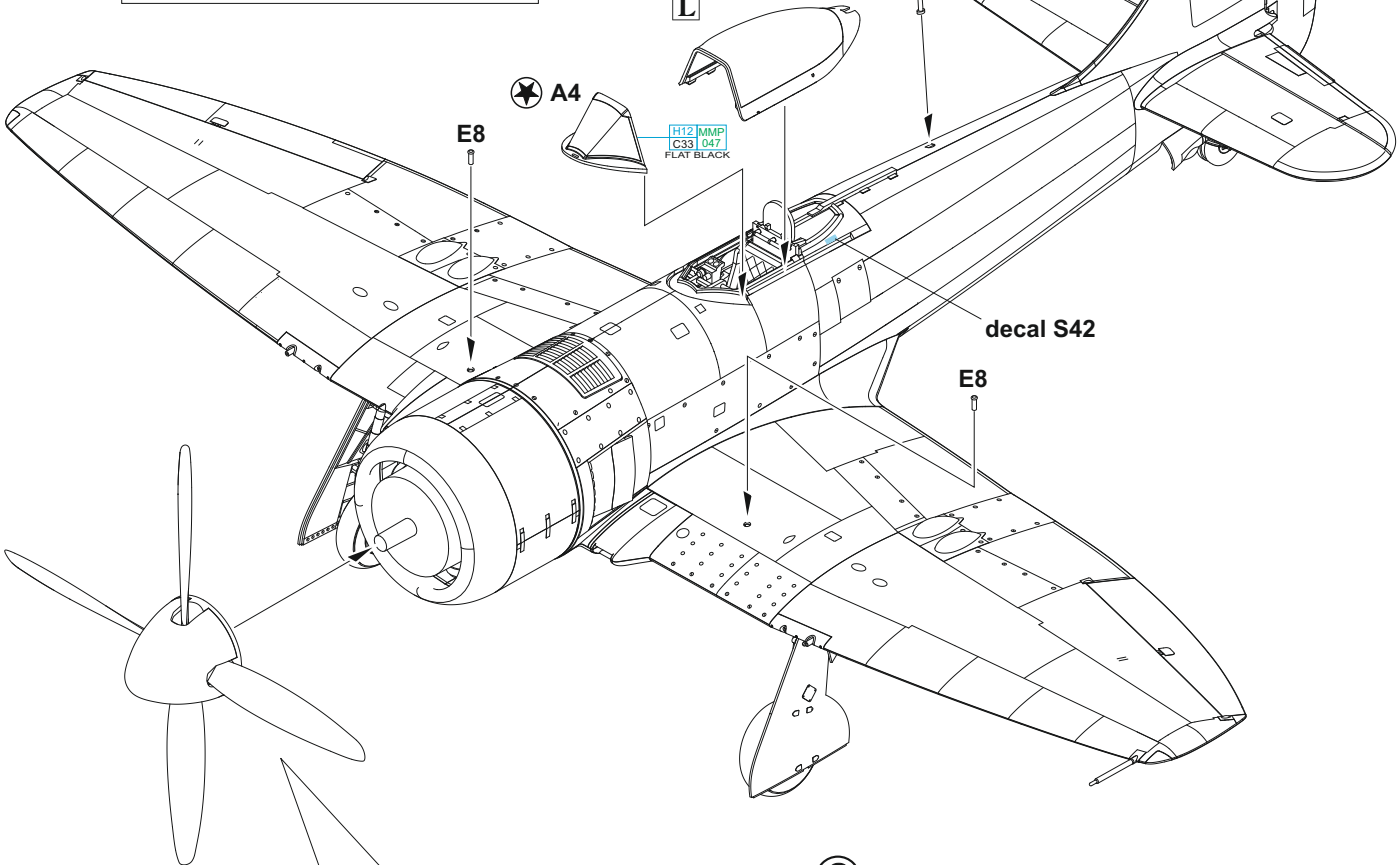

L6

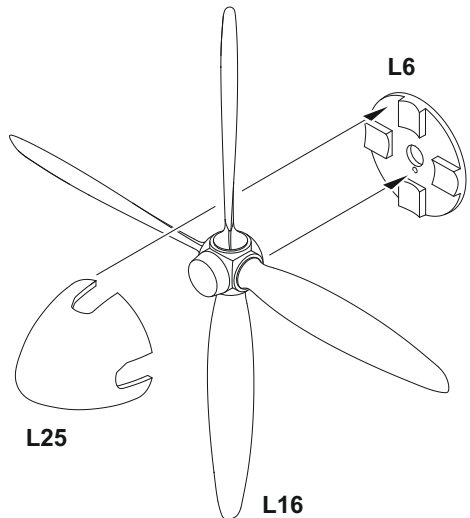
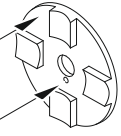

L25

L16

OPEN CANOPY

L

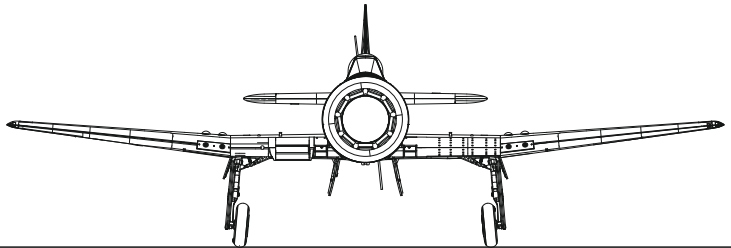
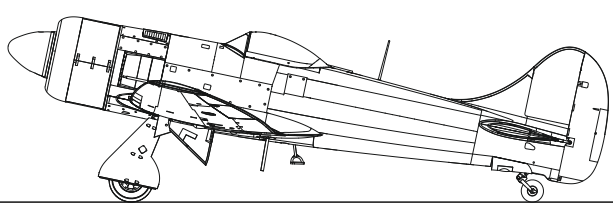
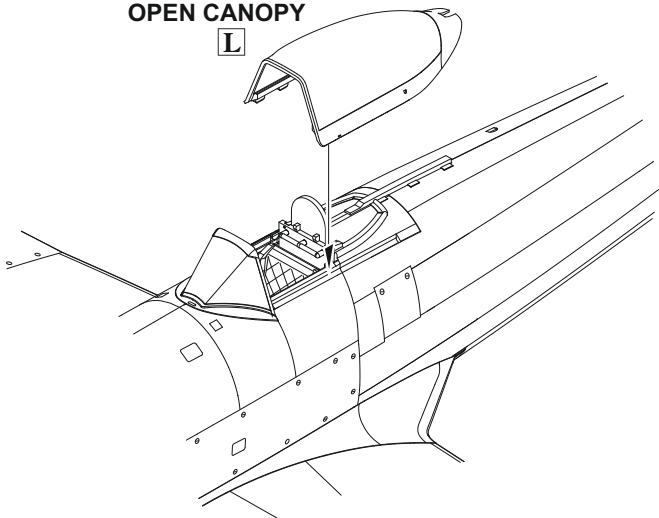

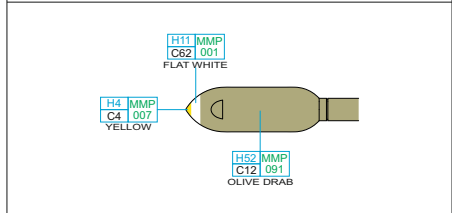
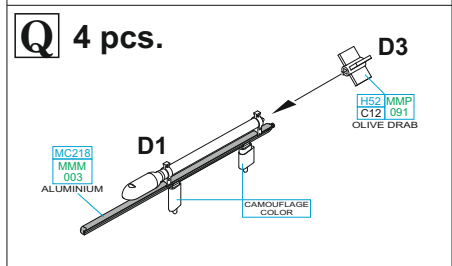
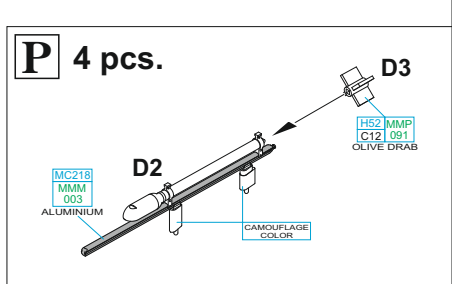
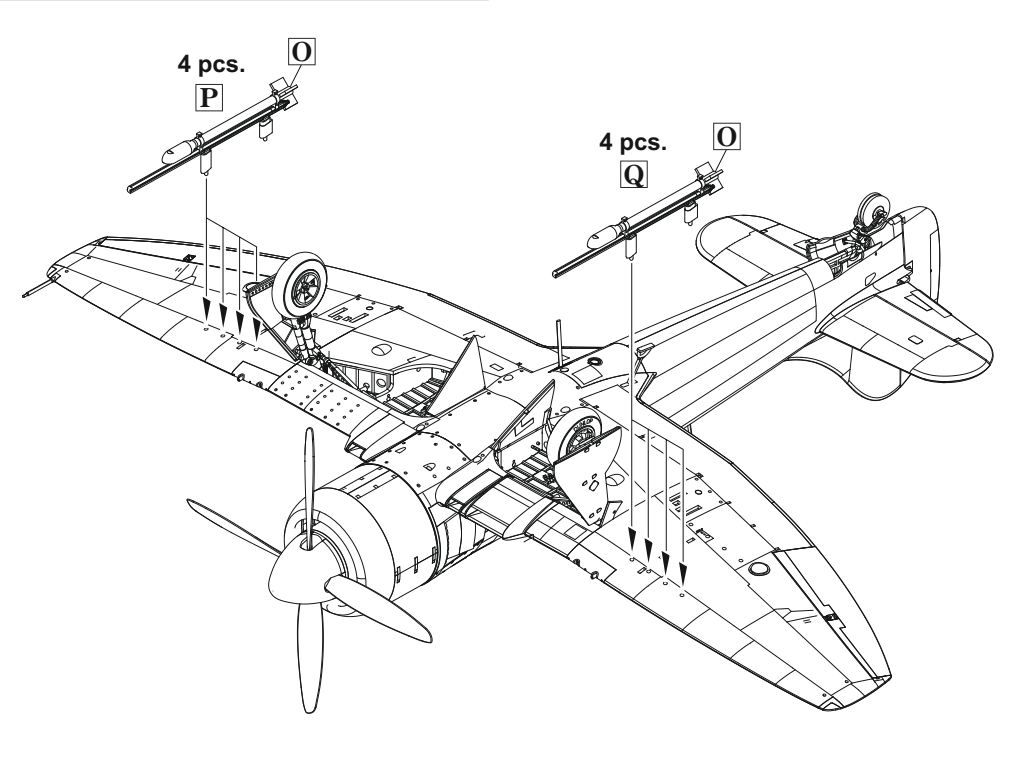
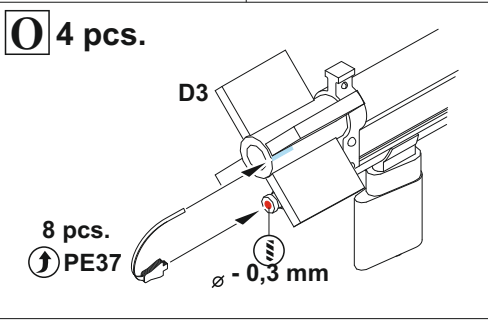
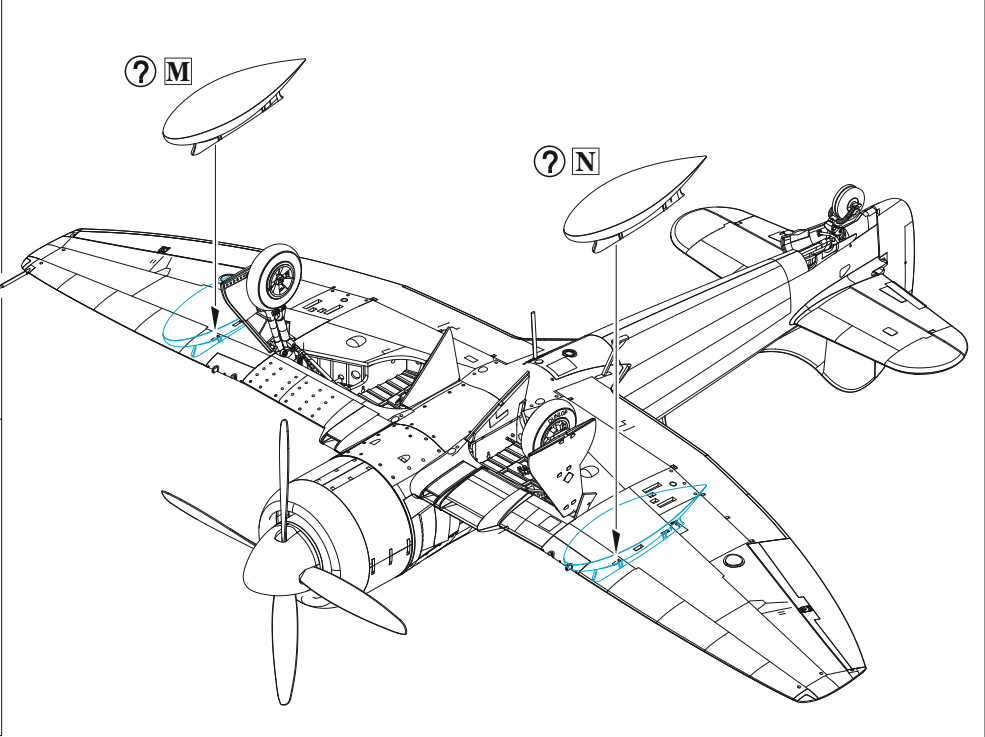
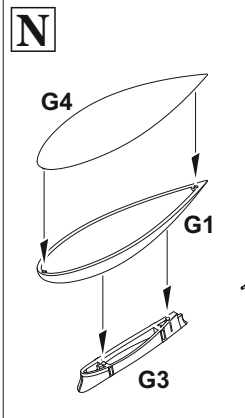
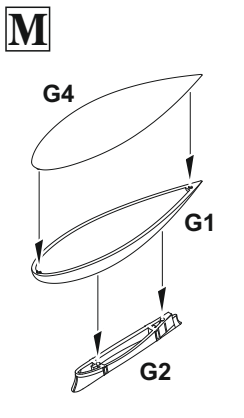

eduard
MASK
82125

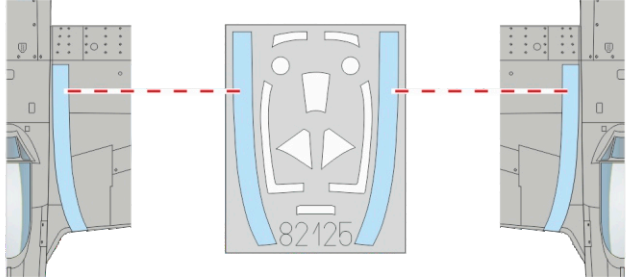
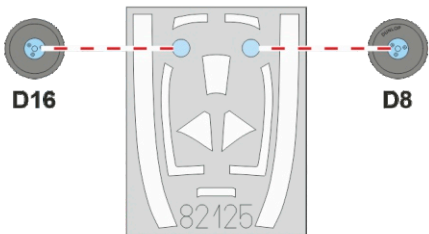
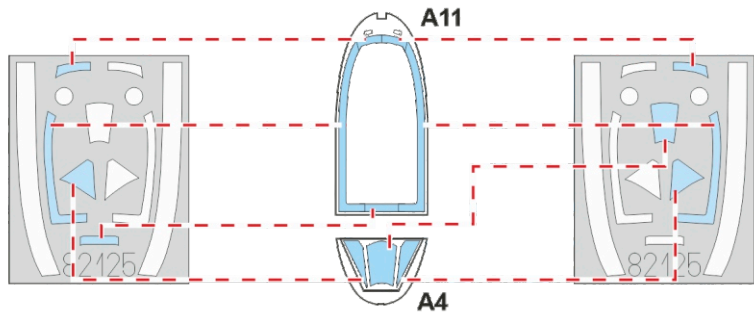

A PR805, No. 33 Sqn, Butterworth, Malaysia, 1951

One of the last operational Tempests Mk.II served with No. 33 Squadron during their operations against Malayan Communists (First Malayan Emergency) from October 1950 to the end of May 1951 (Operation Firedog). Tempests conducted air-to-ground attacks against the Malayan guerillas using 3-inch RP (Rockets Projectiles) as their primary weapon. Towards the end of its operational use PR805 was repainted in the new Long-range Day Fighter Scheme. However, it was withdrawn from use at the end of May 1951 and delivered into storage at Seletar (Singapore). Later on, this aircraft was sold to Pakistan.

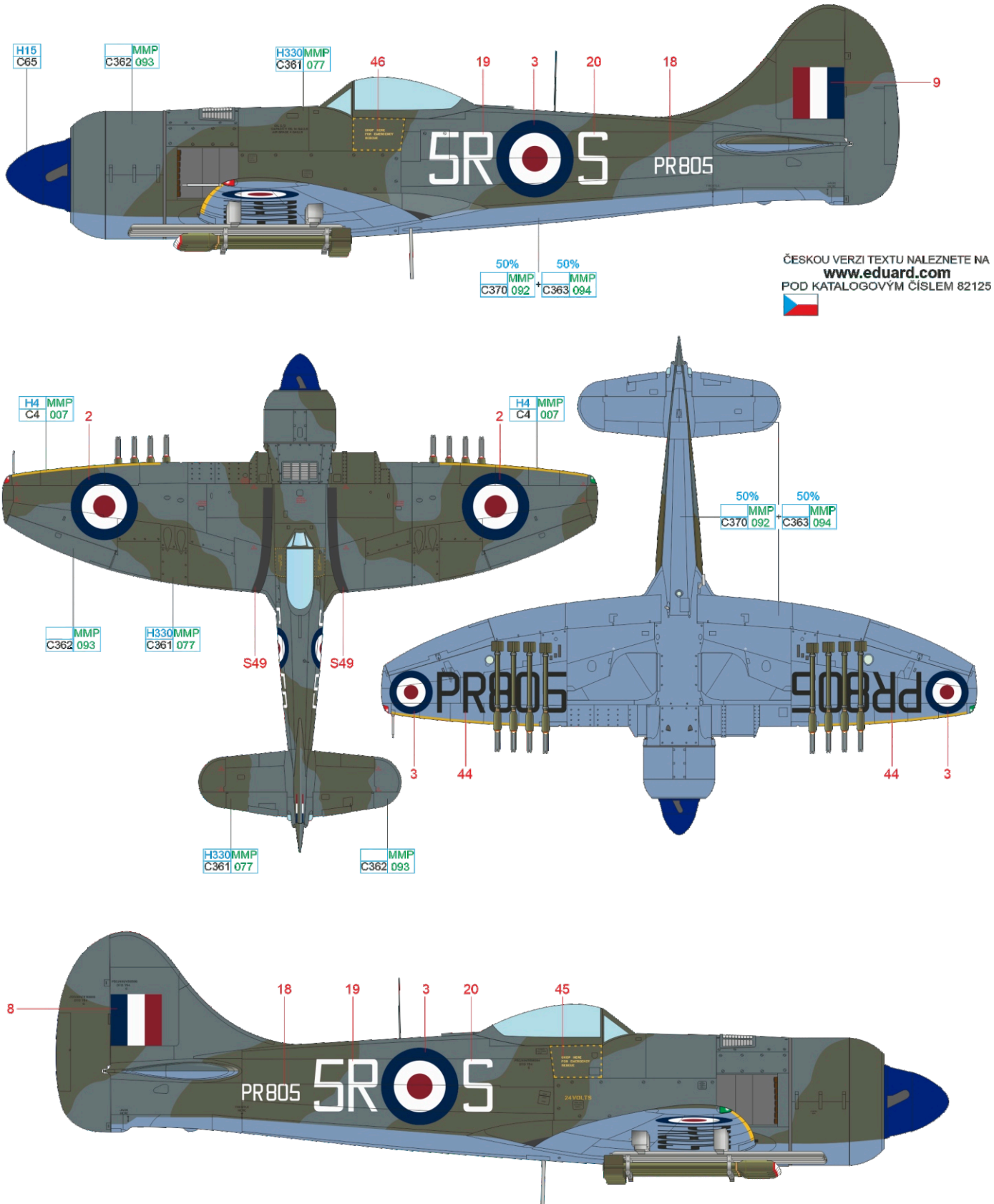

ČESKOU VERZI TEXTU NALEZNETE NA
www.eduard.com
 POD KATALOGOVÝM ČÍSLEM 82125

DARK GREEN	H330 MMP C361 077	OCEAN GRAY	MMP C362 093	MEDIUM SEA GRAY	H335 MMP C363 094
AZURE BLUE	MMP C370 092	SKY	H74 MMP C368 080	YELLOW	H4 MMP C4 007
BLUE	H15 C65				

B PR772, S/Ldr G. T. A. Douglas, No. 152 Sqn, Risalpur, India, November 1946

The wartime No. 152 Sqn had disbanded in March 1946 but was reformed in May 1946 by renumbering No. 136 Sqn (Spitfire-equipped). However, the newly reformed unit was planned to receive Tempests Mk.II and the first of these arrived at Risalpur in July 1946. The following month, the unit received a new commanding officer, S/Ldr G. T. A. Douglas, along with its full complement of 16 Tempests. The squadron's activities were severely hampered due to the lack of both air and ground crew and of Tempest spares. S/Ldr Douglas adopted PR772 as his personal Tempest and it was coded UM-D; it was camouflaged in the DFS at this time. However, at the beginning of September, Douglas was posted to Delhi and F/Lt D. J. M. Coxhead assumed command in his absence. Meanwhile UM-D was repainted in the Aluminium scheme; it also gained the colored spinner and squadron badges when it and five other Tempests from the unit took part in a fire-power demonstration for the Staff College at Quetta on November 10, 1946. By the time No. 152 Sqn was disbanded at the end of January 1947 its Tempests had been flown to No. 5 Sqn at Peshawar, for transfer to RIAF units, but PR772 was retained by No. 5 Sqn RAF, becoming OQ-R, once again a CO's aircraft.

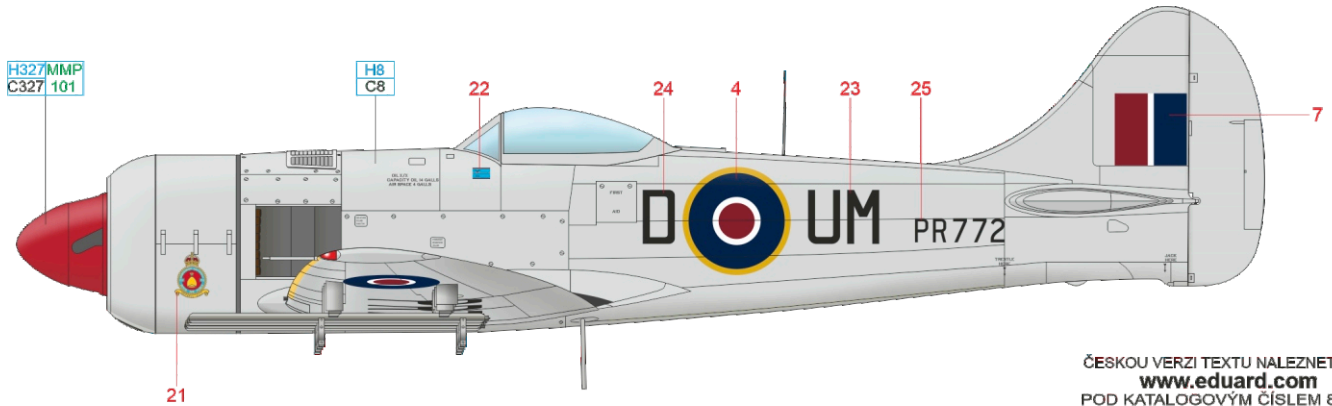

ČESKOU VERZI TEXTU NALEZNETE NA
www.eduard.com
 POD KATALOGOVÝM ČÍSLEM 82125

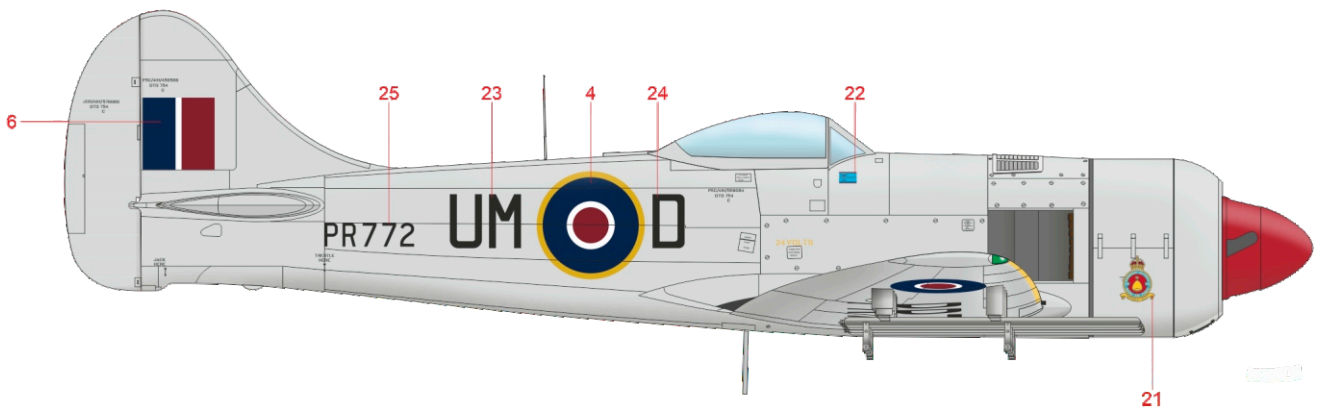
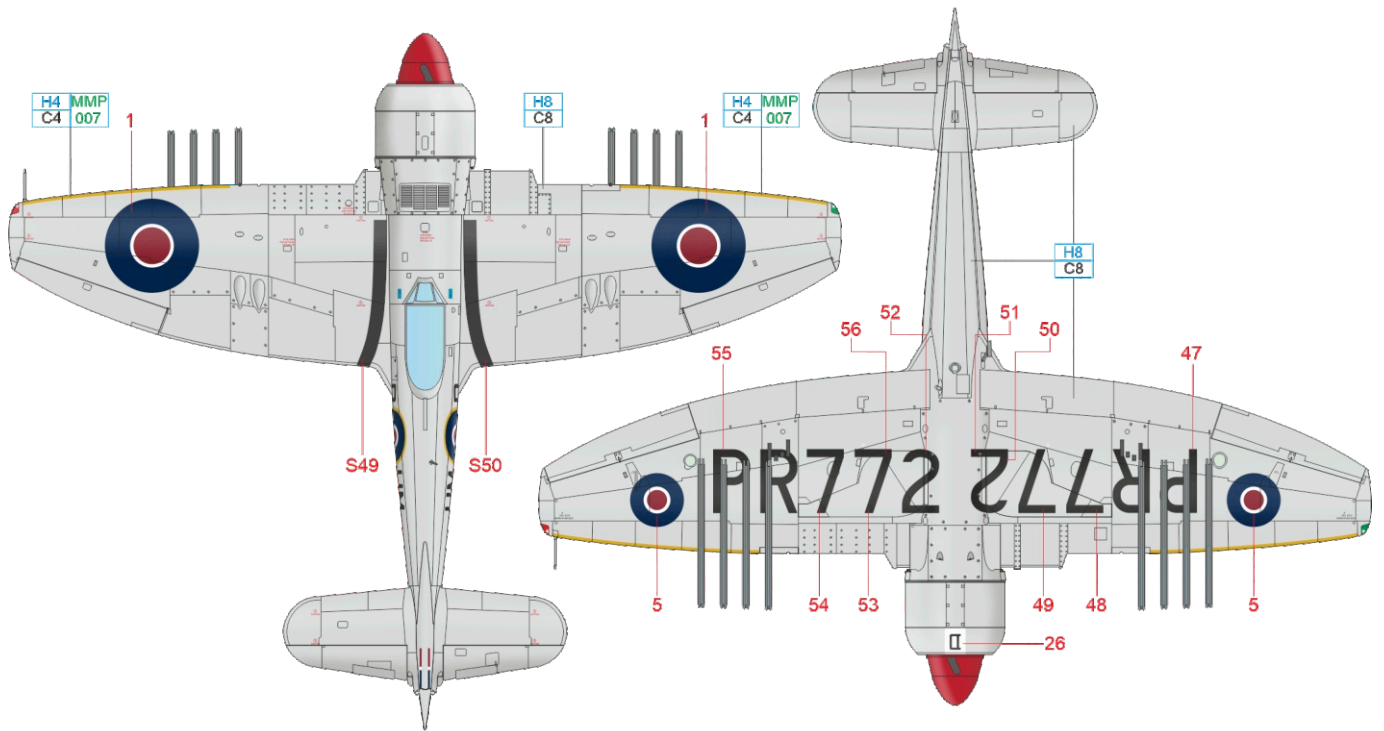

SILVER	H8 C8	RED	H327/MMP C327 101	YELLOW	H4 MMP C4 007
--------	-------	-----	-------------------	--------	---------------

C PR782, No. 16 Sqn, RAF Fassberg, Germany, 1948

After the 2nd TAF was renamed British Air Forces of Occupation (BAFO), the main task for units deployed in Germany changed from keeping an eye on former enemy to safeguarding the West from its former allies in the east. In a period of great reorganization, a Spitfire fighter-reconnaissance unit, No. 16 Squadron, was disbanded at Celle (Germany) on April 1, 1946, but was reformed at RAF Fassberg on the same day, by renumbering No. 56 Squadron. The unit used Mk.V Tempests until August 1946, when they began conversion to the Tempest Mk.II. On August 6, F/O D. W. Baldock flew his Tempest V, EG-V, back to the UK and collected a brand new Tempest II, PR782 which he flew back to Fassberg, via Eindhoven, the next day; it would also be coded EG-V, his allocated aircraft. On September 14, he flew it back to the UK, along with eight other Tempests from his squadron, to take part in a massive Battle of Britain commemorative fly-past over London. PR782 would serve with the squadron through to December 1948 when it was replaced by a De Havilland Vampire jet. PR782 then flew for three months with No. 26 Sqn before transfer to No. 33 Sqn, who took it to Malaya in August 1949; it was scrapped there following a flapless landing at Butterworth when it overshot the runway and the undercarriage collapsed.

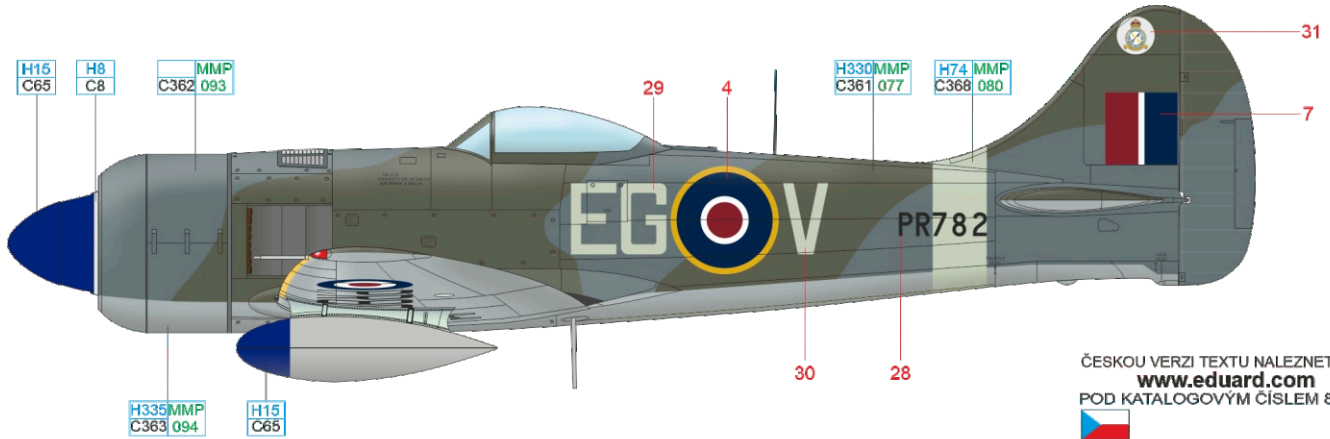

ČESKOU VERZI TEXTU NALEZNETE NA www.eduard.com POD KATALOGOVÝM ČÍSLEM 82125

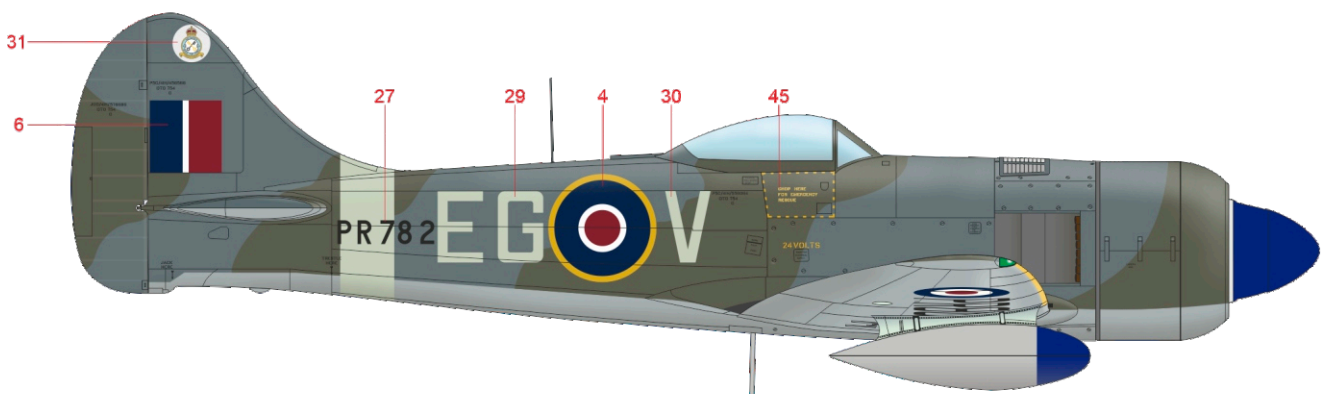
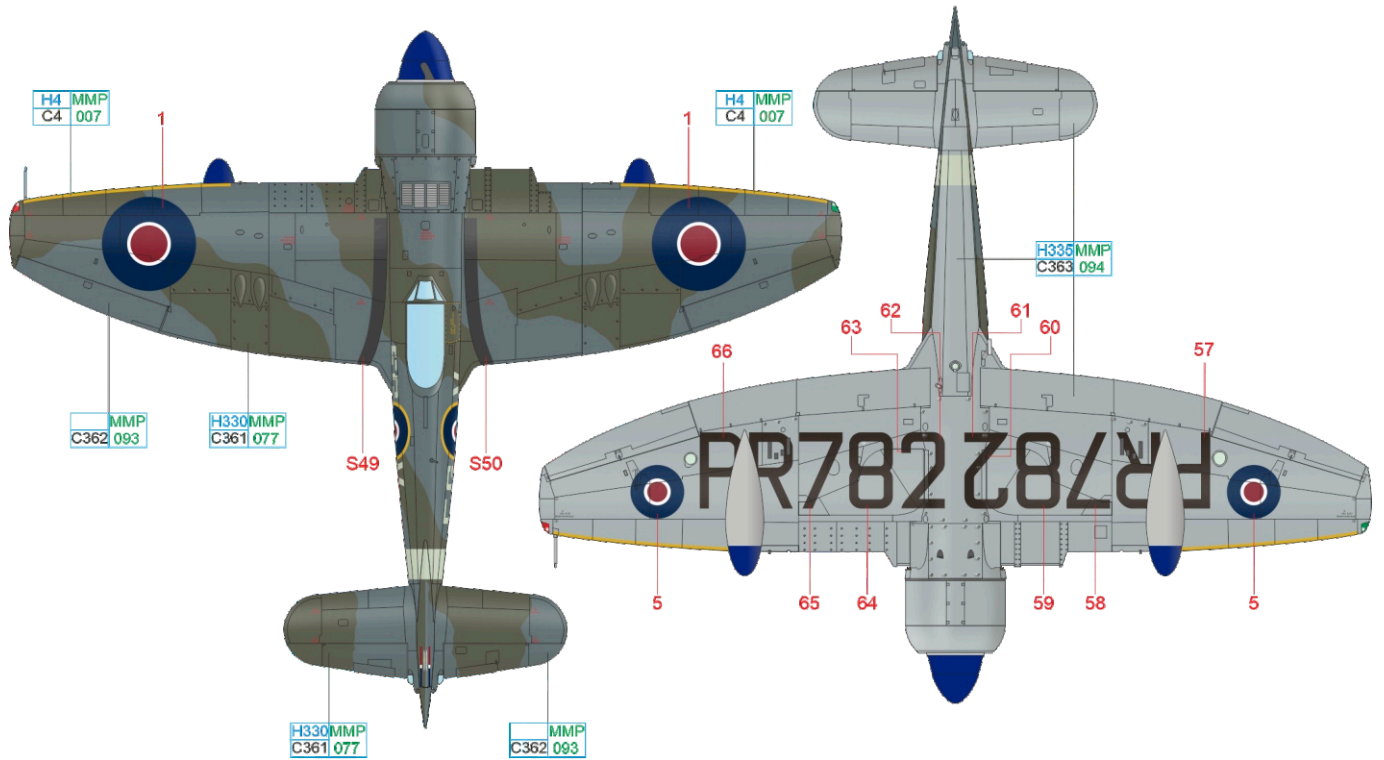

SKY	H74 MMP C368 080	YELLOW	H4 MMP C4 007	BLUE	H15 C65
DARK GREEN	H330MMP C361 077	OCEAN GRAY	MMP C362 093	MEDIUM SEA GRAY	H335MMP C363 094
		SILVER	H8 C8		

D A152, No. 5 Squadron, Royal Pakistan Air Force, 1949

Pakistan obtained their Mk.IIs following partition of Pakistan and India and establishment of the RPAF. Pakistan took over 35 Tempests, all inherited from RAF. These aircraft formed Nos.1 and 5 Squadrons RPAF established on August 15, 1947, with aircraft arriving a month later; No.1 Sqn was later renumbered No.9. All Mk.IIs were overhauled at RPAF Drigh Road in Karachi, as they were received in bad condition. In the process they got also new serials A100–A127 during 1948 and the same year Hawker delivered batch of Mk.IIs already in Desert Scheme colors (A128–A151). The A152 was one of four or five aircraft which were returned to the service in 1949 (the original aircraft inherited from India) using new and also cannibalized parts from other „grounded“ aircraft. It seems logical and probable the aircraft obtained the already used Desert Scheme, but not sure. The Day Fighter Scheme of RAF is also possible according to some sources. What's sure are the white identification chevrons on fuselage and wings used for quick identification of RPAF's Tempests in the air and bottom cockades without the yellow outline contrary to the standard markings. It is up to the modeler to choose which camouflage colors prefers according to his knowledge, as the sources are rather scanty. We tend to believe it was the Desert Scheme.

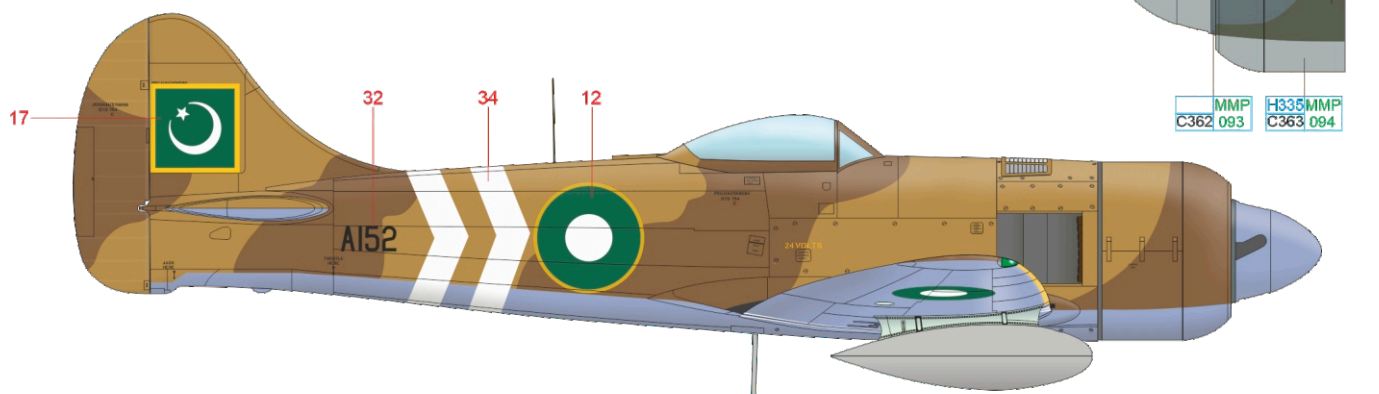
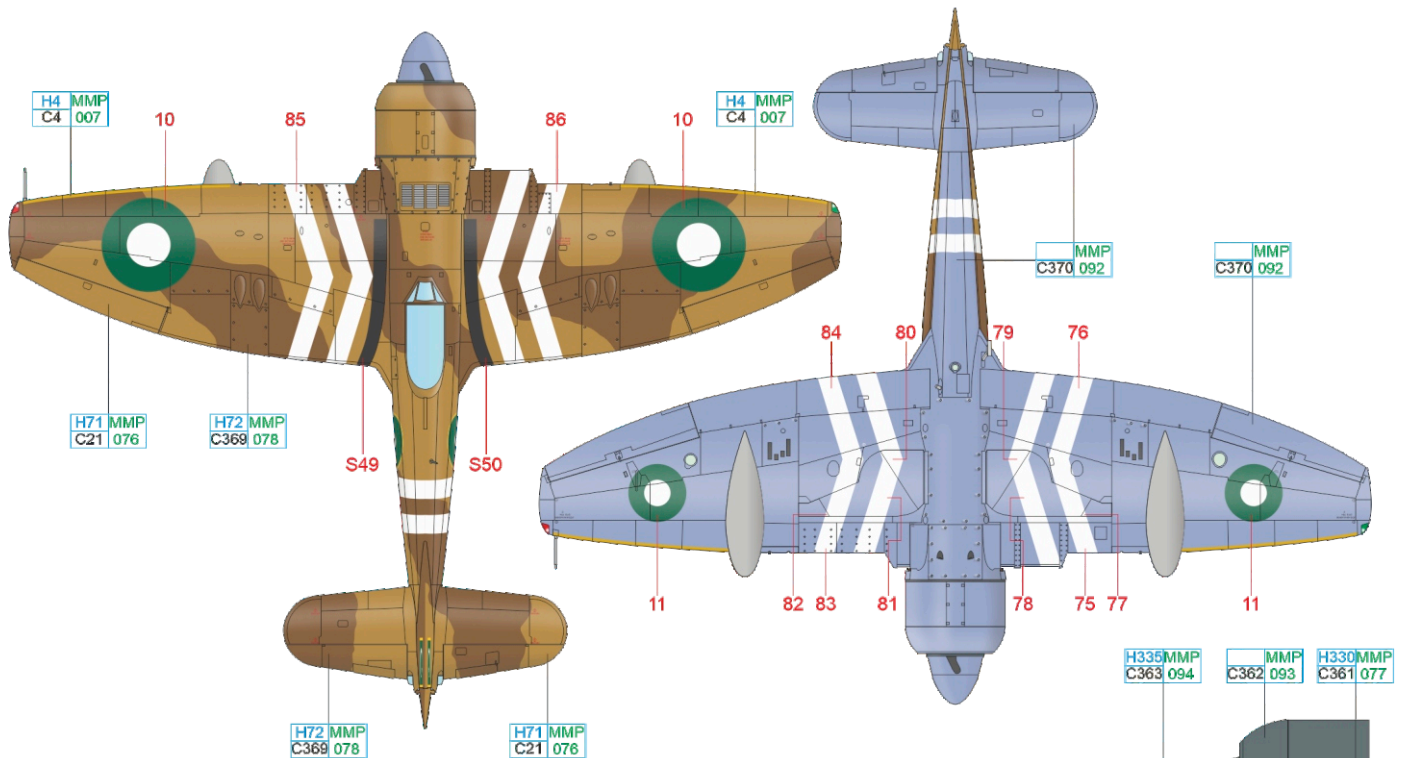
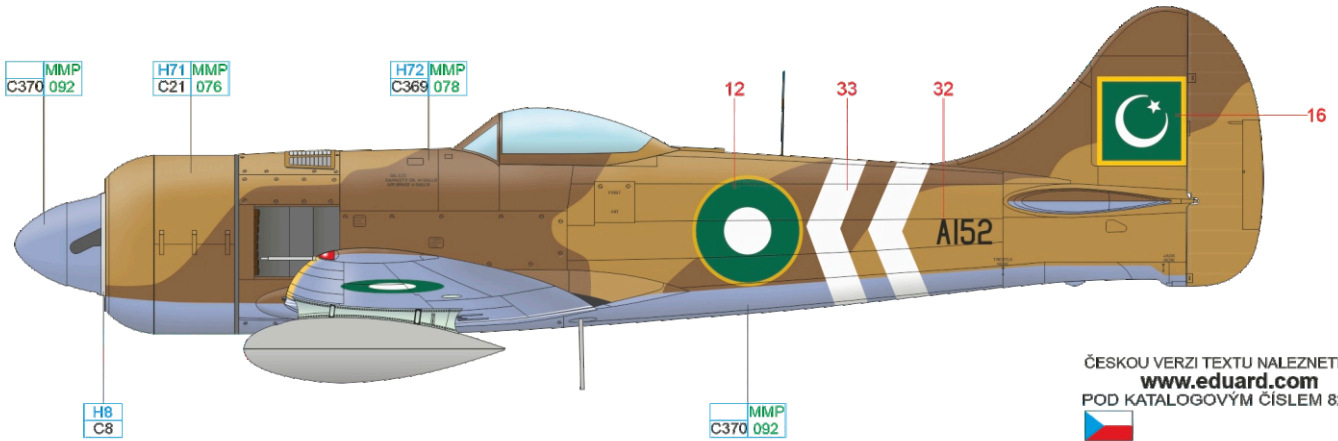

DARK GREEN	H330 MMP C361 077	OCEAN GRAY	MMP C362 093	MEDIUM SEA GRAY	H335 MMP C363 094	SILVER	H8 C8
DARK EARTH	H72 MMP C369 078	MIDDLE STONE	H71 MMP C21 076	AZURE BLUE	MMP C370 092	YELLOW	H4 MMP C4 007

E PR666, Sqn Ldr T. H. Meyer, No. 30 Sqn, Santa Cruz, Bombay, India, 1946

S/Ldr T. H. Meyer used several aircraft named Joe Soap, which is an imaginary name for a gullible person who can be fooled or misled easily. Joe Soap I and II were Mohawks flown by Meyer during the hostilities and Joe Soap III was a Spitfire; he marked his Tempest Mk.II as Joe Soap IV (not III as stated elsewhere) and at some point, the aircraft got the R letter in the code modified to the B, creating the "BS" code, which is abbreviation for "Bull Shit". This might well be a reaction to the situation in the RAF at the time, as the slow rate of demobilization caused discontent among the personnel, or it could have been his favorite expletive. Some illustrations show the part of inscription "Joe Soap" at the bottom of the letter R, but a close look at the photo shows it is in fact an unbroken bar. It is not known whether the inscription Joe Soap IV was repeated on the starboard side.

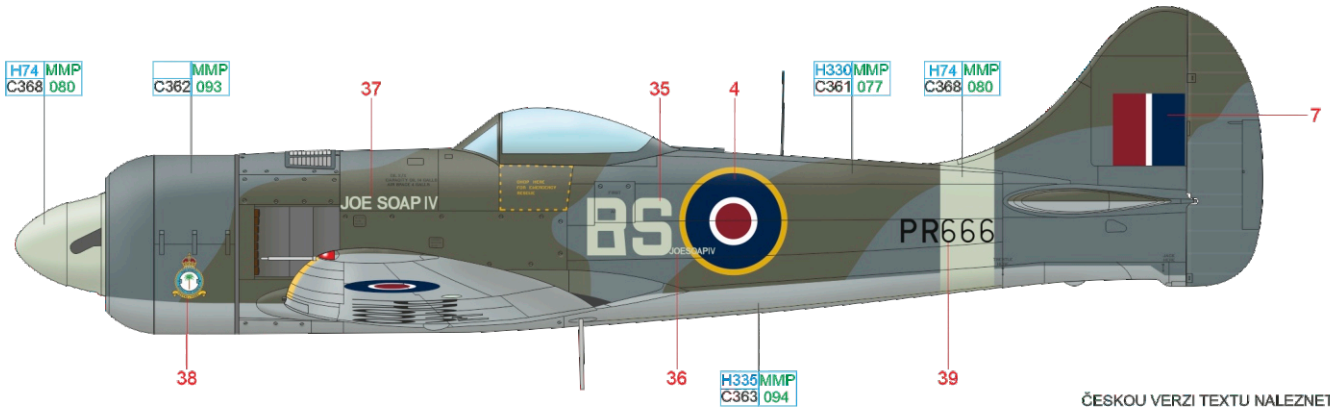

ČESKOU VERZI TEXTU NALEZNETE NA www.eduard.com
 POD KATALOGOVYM ČÍSLEM 82125

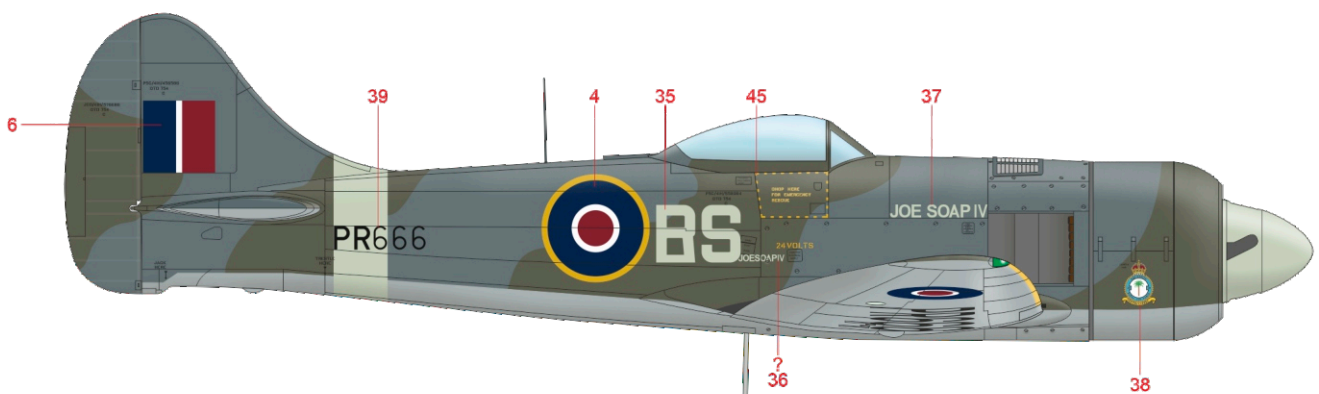
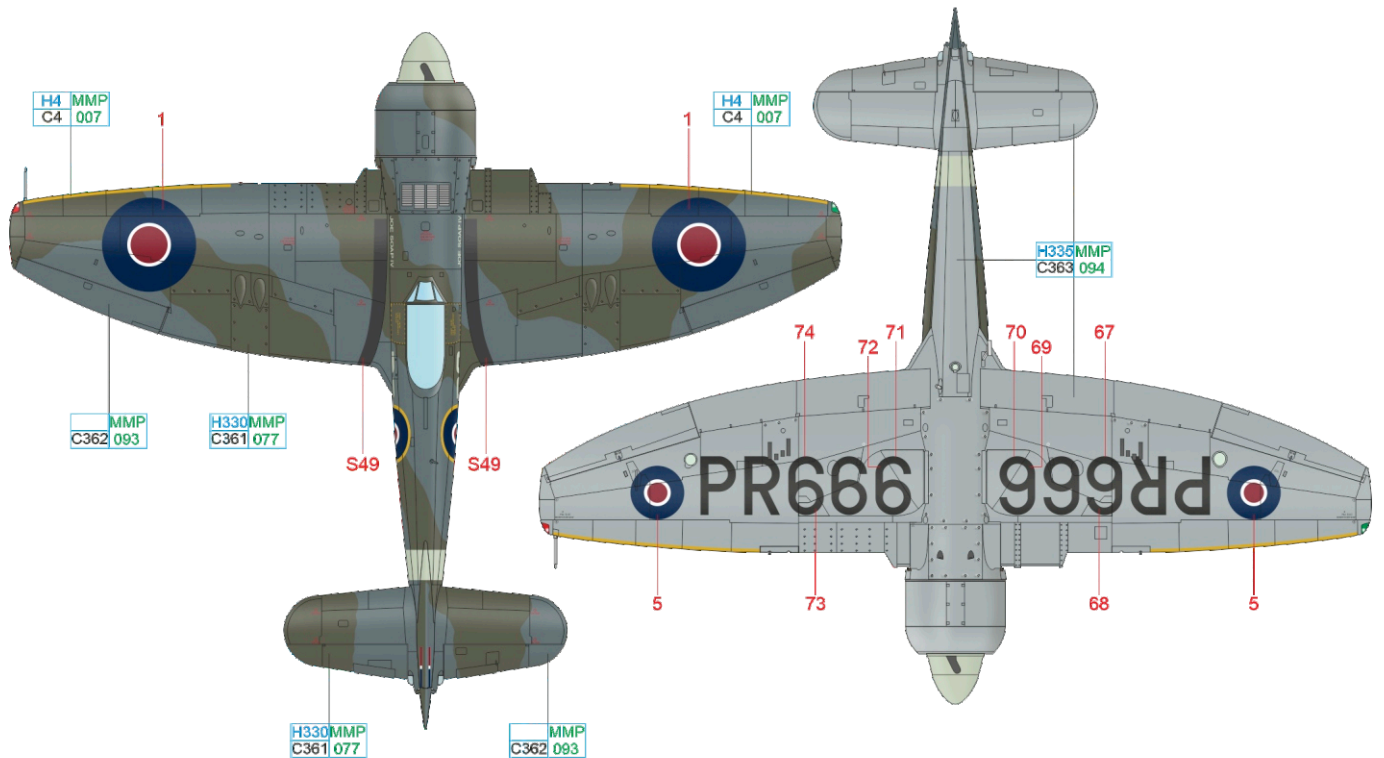
SKY	H74 MMP C368 080	YELLOW	H4 C4 007
DARK GREEN	H330MMP C361 077	OCEAN GRAY	MMP C362 093
		MEDIUM SEA GRAY	H335MMP C363 094

F HA598, No. 7 Sqn, Royal Indian Air Force, 1947

Some 124 Tempests Mk.II were transferred to the RIAF from the RAF squadrons departing India. First to use them was No. 3 Sqn at Kolar in September 1946 with Nos. 10 and 4 Sqn following. In mid 1947 Nos. 7 and 8 Sqn added to the India Tempest strength. Two other Squadrons of RIAF converted to Tempests later in 1947, the No. 1 and No. 9, but these were almost immediately transferred to Pakistan, becoming No. 5 and No. 9 RPAF squadrons. India brought another 89 Tempests from Hawker, all of them full refurbished and, if necessary, modified to full tropical standard. The latter was the case of for MW809 which became HA598; this makes it an exception from the PR series in this kit but puts it on par with these thanks to the upgrade technically. No. 7 Sqn was the first unit to exchange Tempests for De Havilland Vampire jets in 1949; their last Tempests departed in December 1949.

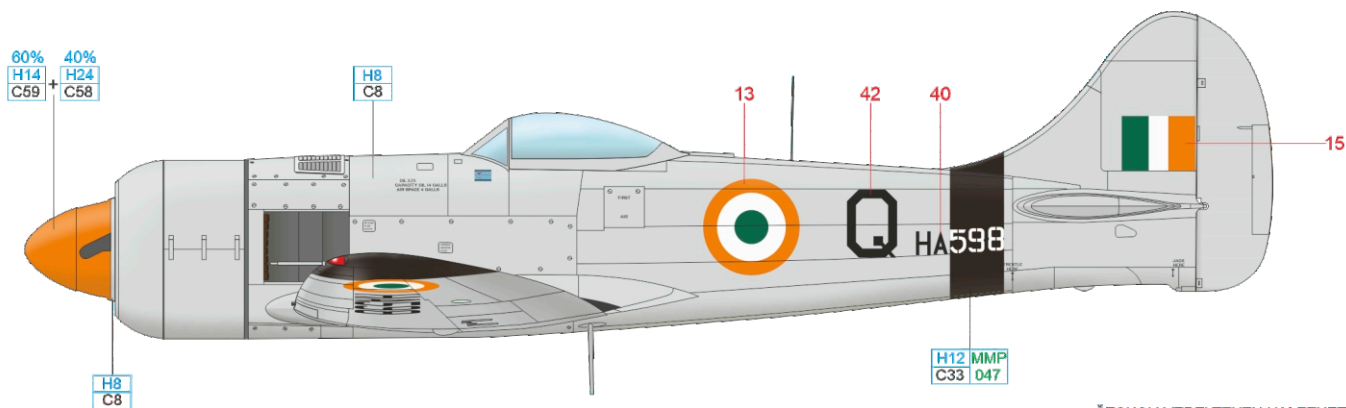

ČESKOU VERZI TEXTU NALEZNETE NA
www.eduard.com
 POD KATALOGOVÝM ČÍSLEM 82125

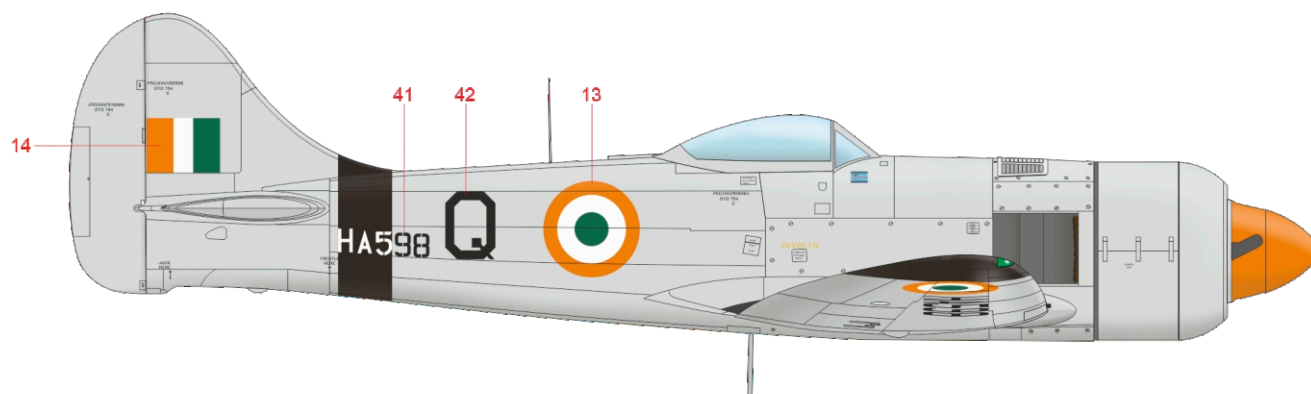
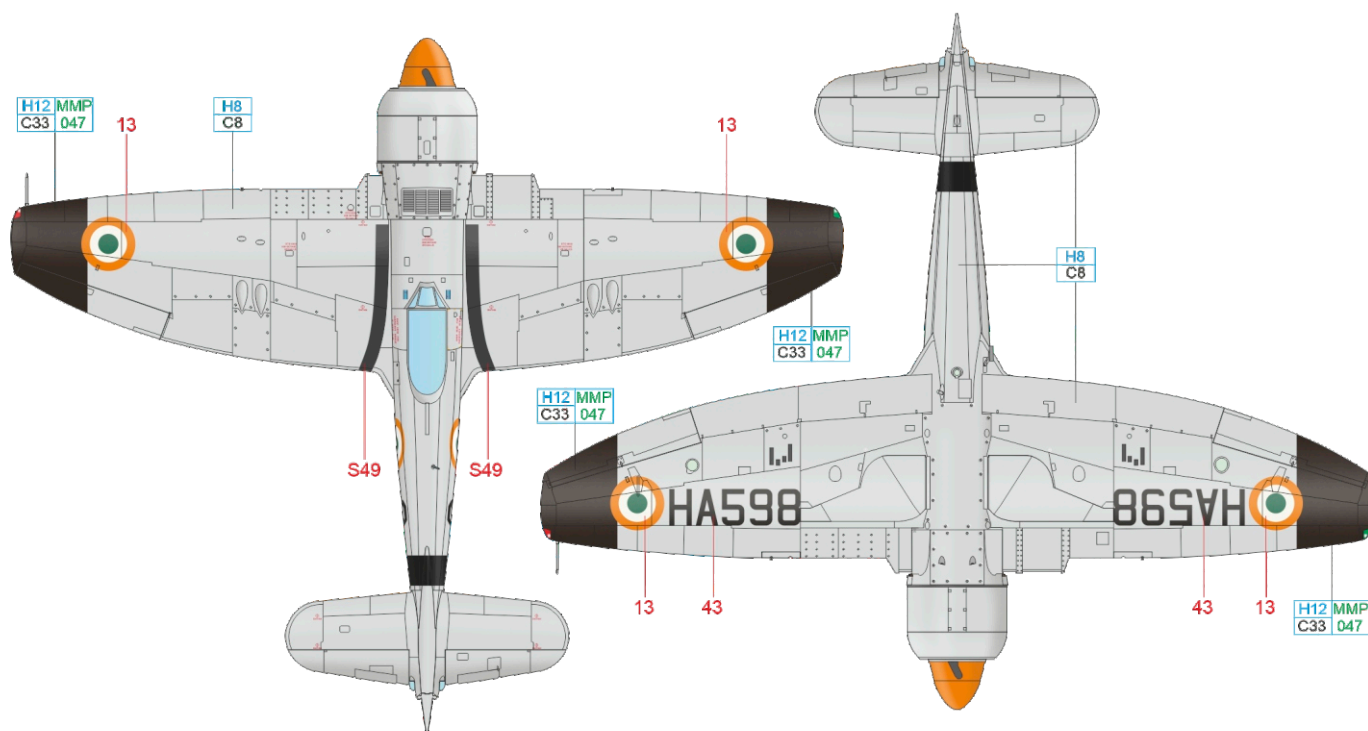

ORANGE	H14 C59	ORANGE	H24 C58
SILVER	H8 C8	FLAT BLACK	H12 MMP C33 047
		YELLOW	H4 MMP C4 007

