

SE.5a Wolsley Viper

eduard

BRITISH WWI FIGHTER

1/48 SCALE PLASTIC KIT

ProfIPACK
edition

#82131



INTRO

The Royal Aircraft Factory SE.5a is credited with being one of the fastest and deadliest aircraft of World War I. But the story of this 'Spitfire of Great War', as it is sometimes referred to, is not so straightforward. The SE. 5 (Scout Experimental 5) was designed by Henry Folland, John Kenworthy and Frank Goodden as a fighter powered by the new 150hp V8 Hispano-Suiza 8Aa engine. As the rotary engines neared their limitations, in-line liquid cooled engines were supposed to be a more promising way to fly faster and higher. The first prototype of the new fighter made its maiden flight on November 22nd, 1916 and began a somewhat intricate journey from miserable testing to combat proven glory. The new engine was troublesome and the wing design of the plane had glitches. The first two prototypes were lost in crashes, with chief test pilot at the Royal Aircraft Factory and one of the aircraft's designers, Major F. W. Goodden, losing his life on January 28th, 1917. The problems were partly solved thanks to modifications adopted on the third prototype, thus creating the first production variant of the new fighter.

The SE.5 entered service with No.56 Sqn RFC, during April 1917. The squadron was home to several famous aces. One of them, Albert Ball, was instrumental in honing the SE.5 into a formidable airplane. The new fighter was received with mixed emotions because of its unusually high seat position, large windscreen and armament layout that was composed of fuselage mounted 0.303 Vickers and upper wing mounted 0.303 Lewis machine guns. Ball, together with his mechanic, worked during the nights to address smaller as well as bigger glitches of the new design and most of the changes they made to the design were adopted for all SE.5s at squadron level. The large windscreen was dispensed with and the pilots lowered their seats to a more normal position. But, they always prayed for good visibility from the cockpit. The changes made by No.56 Sqn were shortly adopted for production. The final few SE.5 aircraft built in July 1917 were fitted with a more powerful 200hp Hispano-Suiza 8Ab engine, effectively setting the SE.5a standard. Production of the SE.5 ended after only 77 examples being built. The SE.5a was then produced in high quantities by six manufacturers: Vickers (2164), Austin Motors (1650), Air Navigation and Engineering Company (560), Wolsley Motors Limited (431), Martinside (258) and Royal Aircraft Factory (200). The American Curtiss Aeroplane and Motor Company built one example, as production of some 1000 aircraft was considered there. The US Army Squadrons of the American Expeditionary Force were among those receiving the SE.5a, and the Curtiss supplies would equip them. But the armistice ended this plan.

The SE.5a is frequently compared to another famous WWI fighter, the Sopwith Camel, the last formidable British fighter with a rotary engine. Because of the different engine construction philosophy, the two fighters were very different aircraft. The Camel was highly maneuverable thanks to the centre of gravity pushed very far forward and also because of the sheer inertia of the rotating engine, which made it very fast in a right turn. But the Camel was an unforgiving airplane, dangerous to less experienced pilots. The SE.5a, although very fast, was to the contrary a very stable and forgiving fighter. It was not as agile as the Camel, but still agile enough. And above 10,000 ft it was clearly superior not only to the Camel, but also to most enemy aircraft. Furthermore, the armament of one fixed, fuselage mounted Vickers machine gun, supplemented by a Lewis machine gun affixed to the top of the upper wing made it possible for pilots to attack a high-flying enemy, sneaking up beneath it unobserved. Some pilots questioned this armament arrangement, with two fixed Vickers suggested as a better solution, but early problems with the Constantinesco synchronizing gear spoke against it. In the end, the SE.5 was the first fighter with two machine guns. The Camel entered the field later in 1917. For SE.5a pilots, it was quite easy to pull down the wing mounted Lewis machine gun for reloading, but changing the drum and pushing the weapon back into firing position was a different story. The slipstream could even ram the removed drum into the pilot's face. But, pilots learned how to get the best from the SE.5a, the best of them leading the way. Apart from the aforementioned Albert Ball, there was, for example, James McCudden, a former sapper and air mechanic, later an ace with 57 kills, who used his skills to optimise the engine of his SE.5a for use in high level solo patrols against high-flying Rumpier observers. While 17,000 ft was the ceiling for the usual SE.5a, McCudden was capable of sorties of up to the 20,000 ft level. Another of the more famous men of the RFC, Edward C. Mannock, developed tactics which allowed extraction of the best of the SE.5a's qualities.

Hisso and Viper

Problems with both supply and reliability of the 200hp Hispano-Suiza (nicknamed 'Hisso') engines troubled the SE.5a throughout its service career. As a result, there were a number of engine modifications installed in the SE.5a, both from the French supplier of the Hispano-Suiza, as well as from the British Wolsley firm, whose engines were usually further developments of Hispano-Suiza designs. With the earlier geared engines, the prop shaft was driven by a reduction gear and the propeller rotated counter clockwise (from the pilots perspective). The later direct drive engines had the propeller rotating clockwise. As Hispano Suiza supplied most of the early engines, the nickname 'Hisso' was used for all the planes with the geared engine, whether it came from Hispano-Suiza or Wolsley. For later production, the more reliable direct drive Wolsley Viper became the standard engine and aircraft so equipped were nicknamed 'Viper', again without distinction between suppliers. After the armistice a great sale of army surplus was held, and many planes were offered to the public, including the SE.5a. The price of one airworthy plane was 5 £, which translates to some 1,500 £ at today's values. Some retired pilots, who never flew the SE.5a during the war, brought one just to make one test flight, returning the plane with a discount. Such was the reputation of the SE.5a, enticing the pilots to try them, even if it did cost them a sizeable amount of money! Many of SE.5as were actually sold and were used in air races and also for 'Sky-Writing' purposes in advertising.

ATTENTION



UPOZORNĚNÍ



ACHTUNG



ATTENTION



注意



Carefully read instruction sheet before assembling. When you use glue or paint, do not use near open flame and use in well ventilated room. Keep out of reach of small children. Children must not be allowed to suck any part, or pull vinyl bag over the head.



Před započítím stavby si pečlivě prostudujte stavební návod. Při používání barev a lepidel pracujte v době větrané místnosti. Lepidla ani barvy nepoužívejte v blízkosti otevřeného ohně. Model není určen malým dětem, mohlo by dojít k požití drobných dílů.

INSTRUCTION SIGNS * INSTR. SYMBOL * INSTRUKTION SINNBILDEN * SYMBOLES * 記号の説明

OPTIONAL
VOLBABEND
OHNOUTOPEN HOLE
VYVRTAT OTVORSYMETRICAL ASSEMBLY
SYMETRICKÁ MONTÁŽNOTCH
ZÁREZREMOVE
ODRIZNOUTAPPLY EDUARD MASK AND PAINT
POUŽIT EDUARD'S MASK NABARVIT

PARTS



DÍLY



TEILE



PIĚCES



部品

PLASTIC PARTS

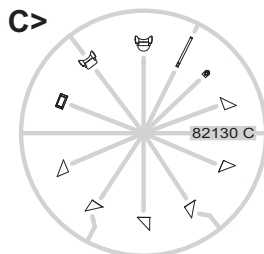
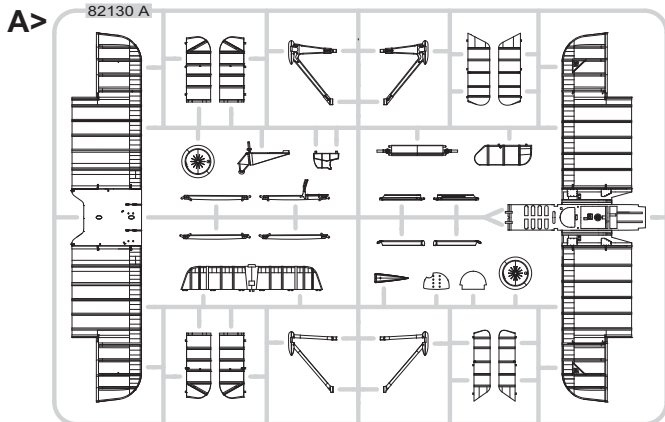
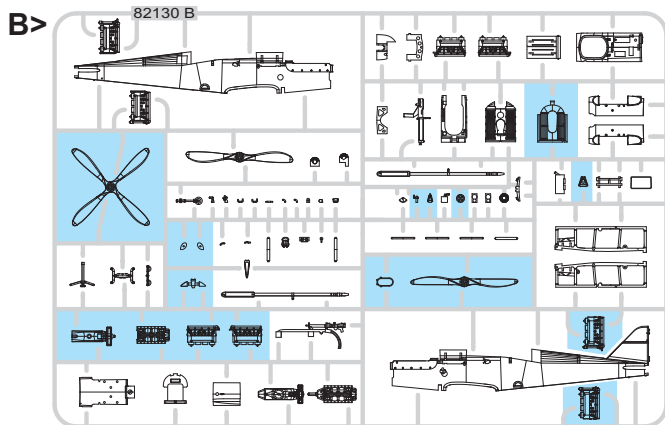
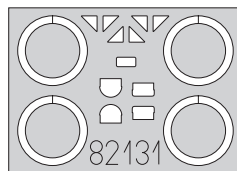
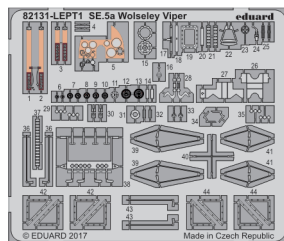
eduard
MASKPE- PHOTO ETCHED
DETAIL PARTS

-Parts not for use. -Teile werden nicht verwendet. -Pièces à ne pas utiliser. -Tyto díly nepoužívejte při stavbě. - 使用しない部品

COLOURS



BARVY



FARBEN



PEINTURE



色

GSI Creos (GUNZE)		
AQUEOUS	Mr.COLOR	
H.3	C3	RED
H.5	C5	BLUE
H.11	C82	WHITE
H.12	C33	FLAT WHITE
H.33	C81	RUSSET

AQUEOUS	Mr.COLOR	
H147	C43	WOOD BROWN
H147	C41	RED BROWN
H151	C11	LIGHT GULL GRAY
H159	C12	OLIVE DRAB
H155	C45	SAIL COLOR
H 309	C309	GREEN

Mr.METAL COLOR		
MCPT4		DARK IRON
MCPT6		ALUMINIUM
MCPT8		BRASS

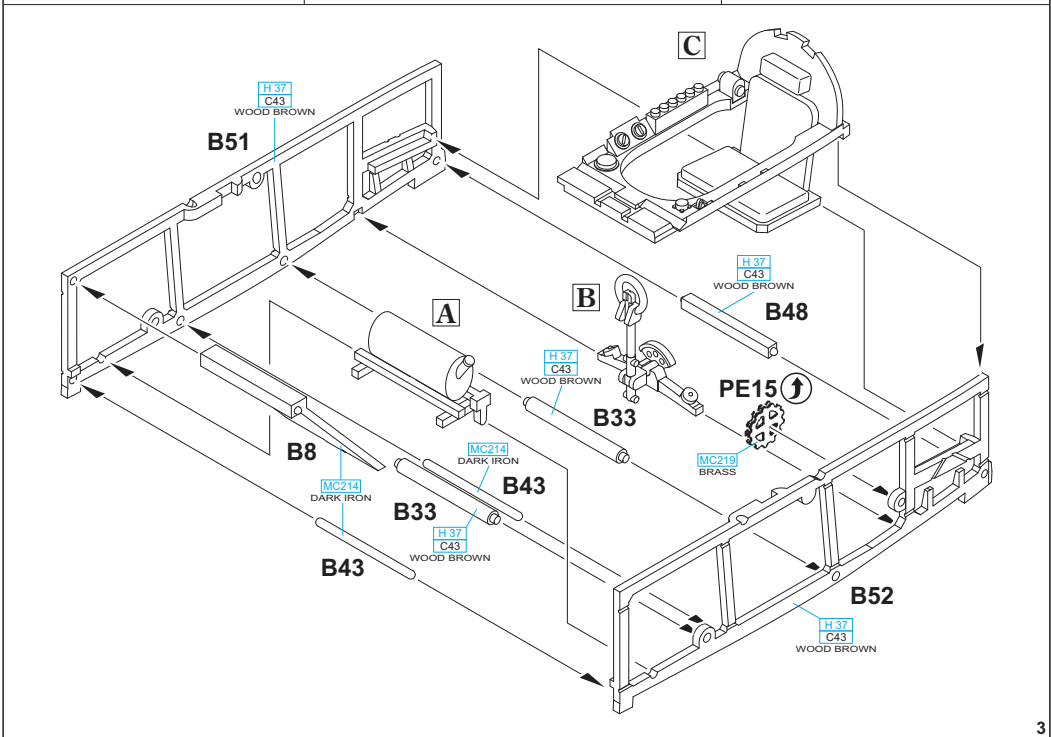
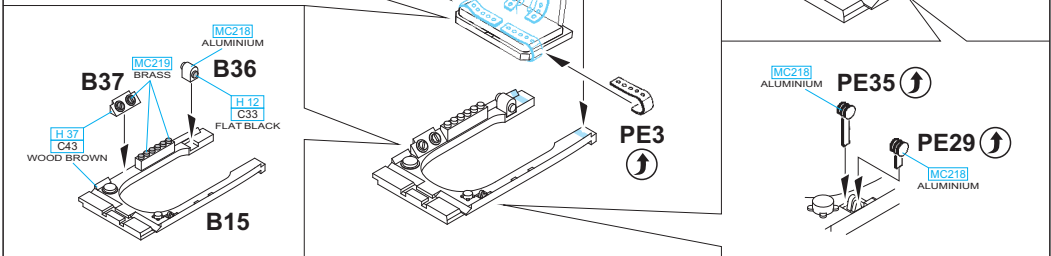
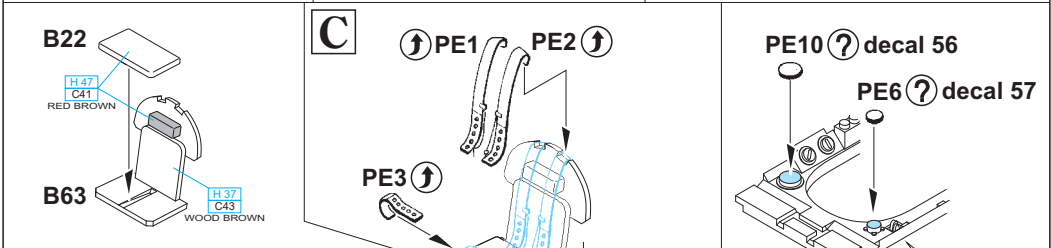
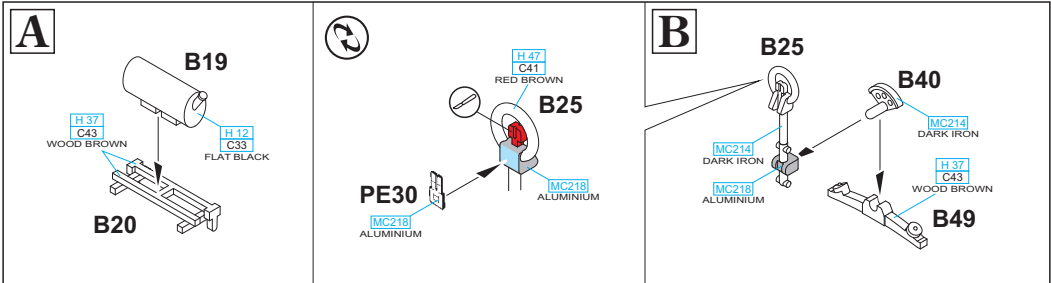

D

step 1

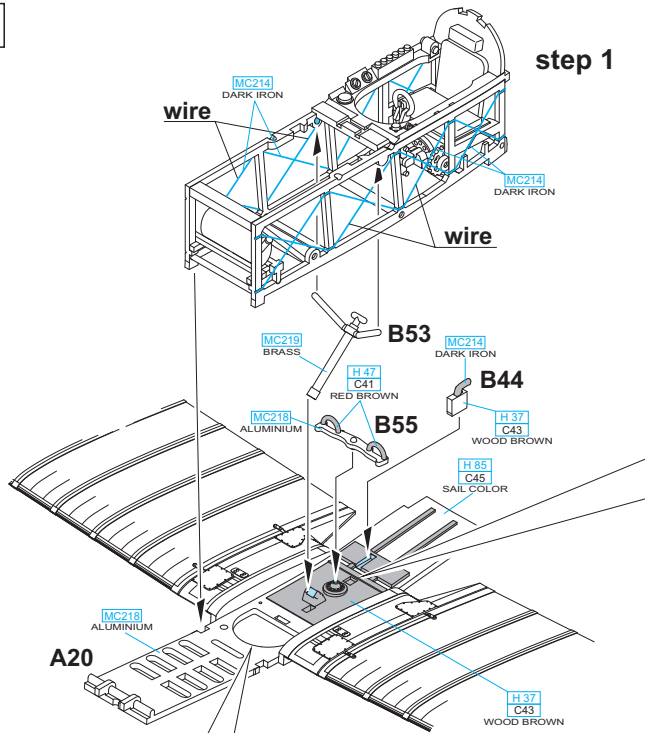

step 2

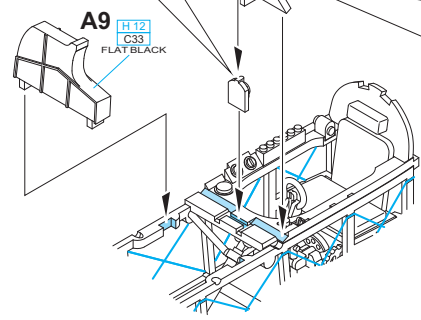
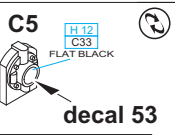
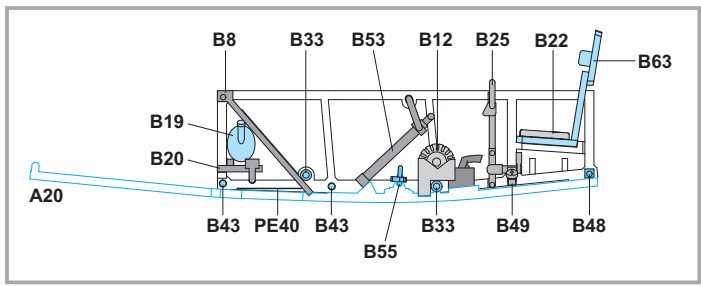
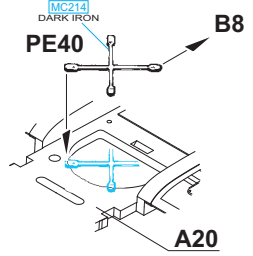
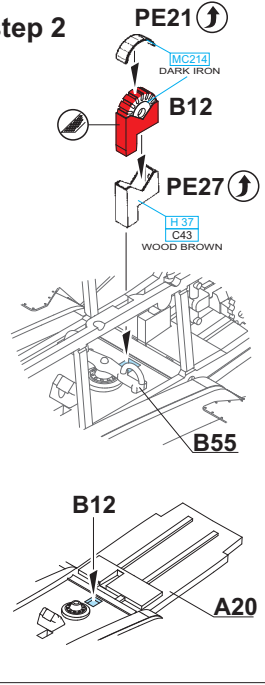

OPTIONAL: decals

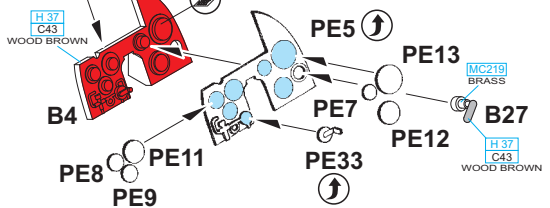
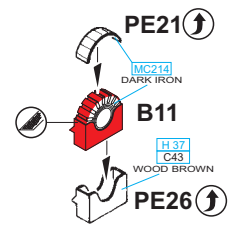
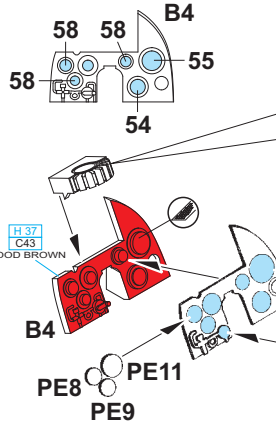

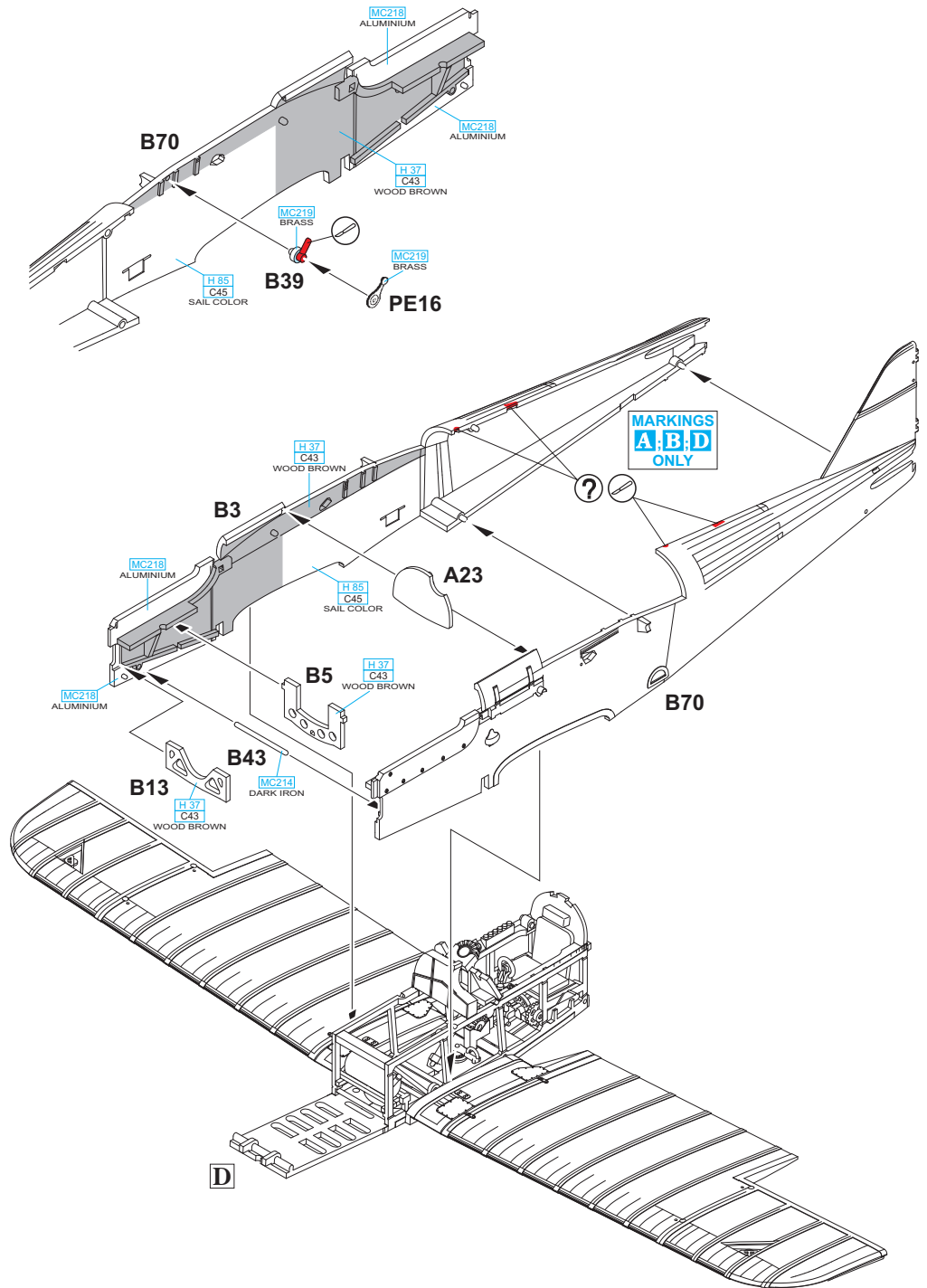

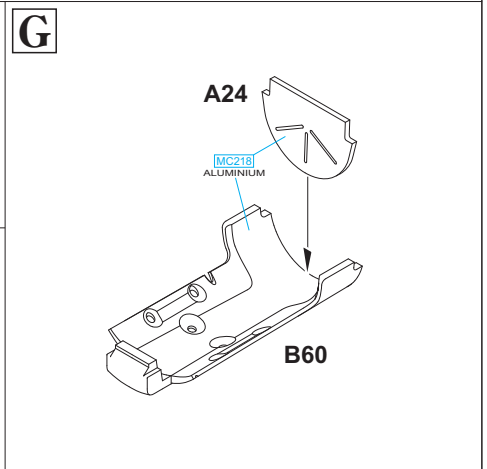
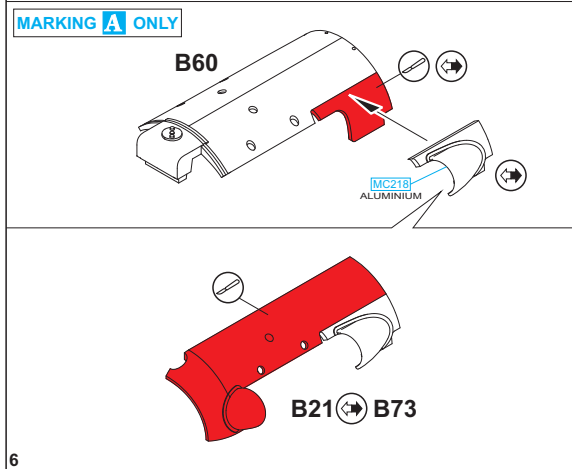
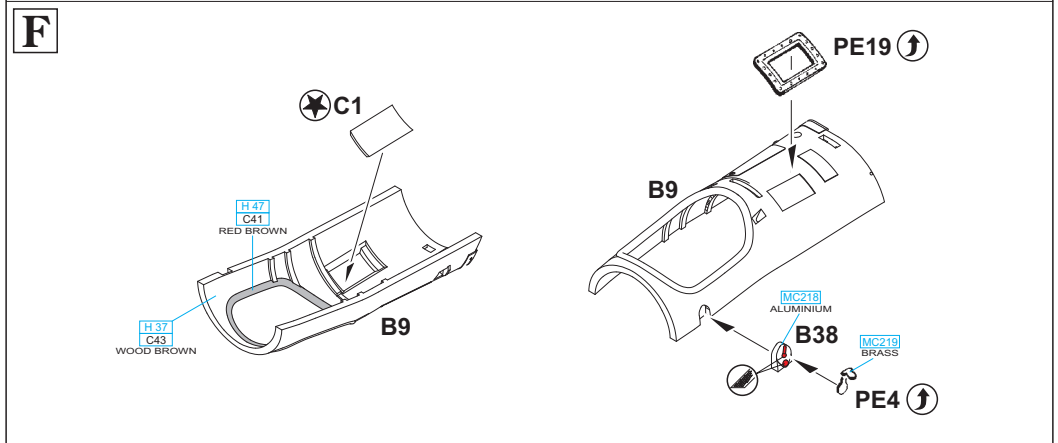
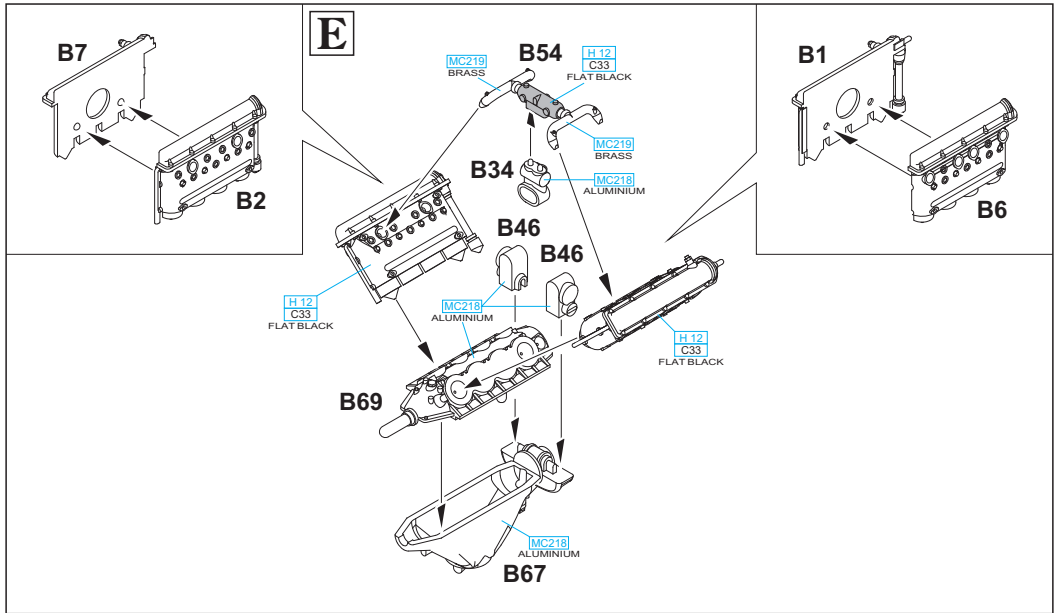

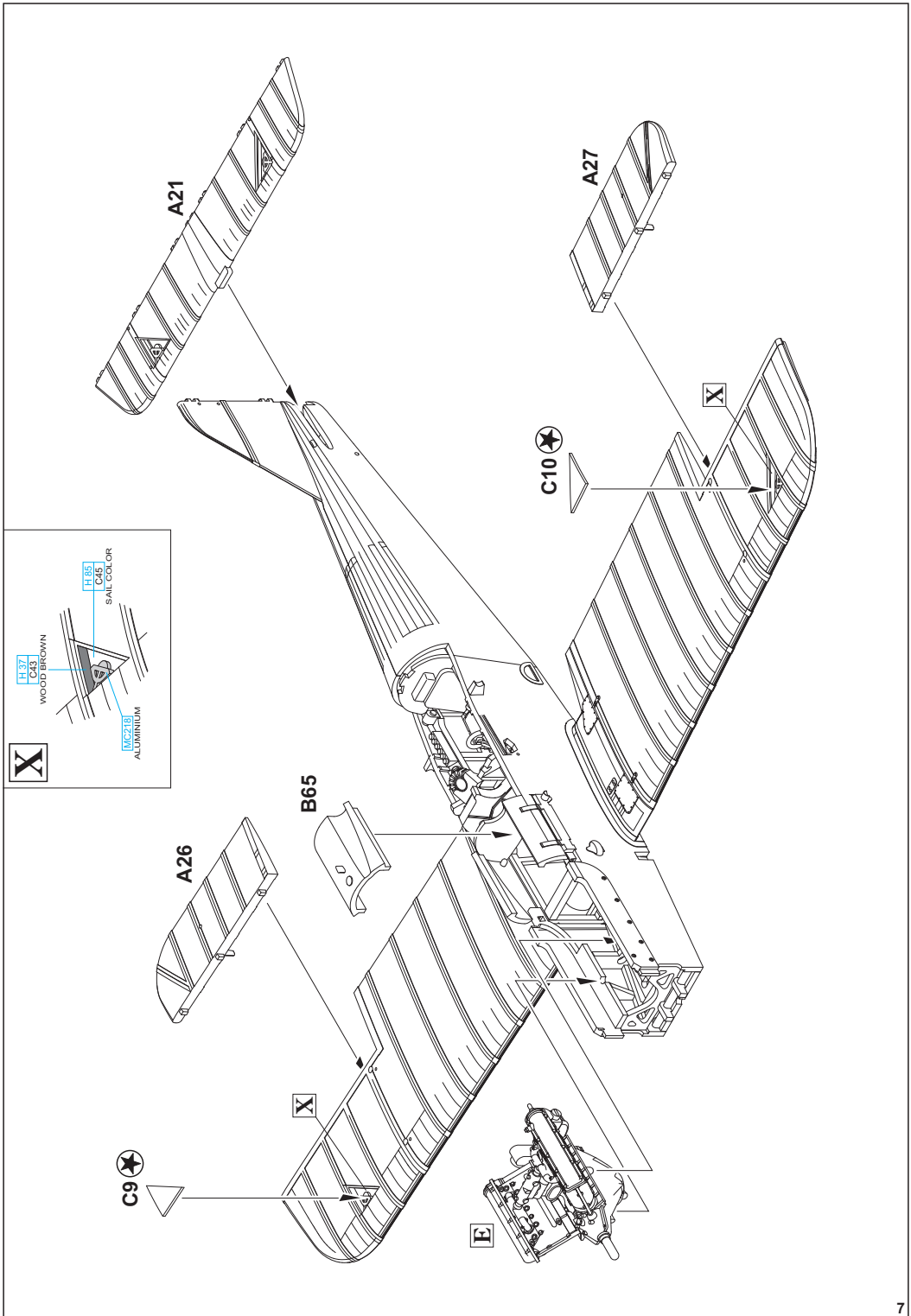

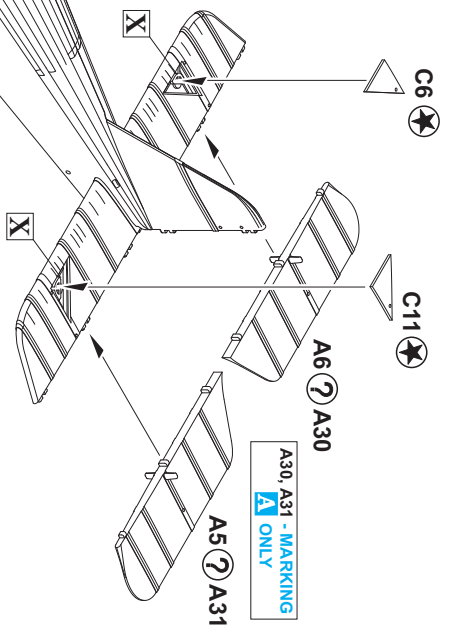
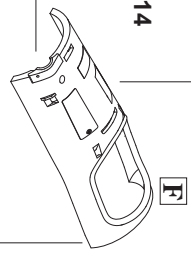
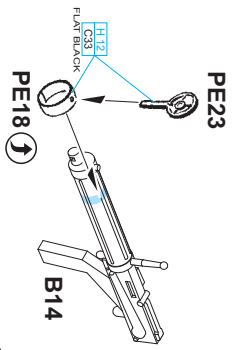
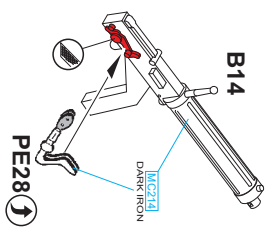
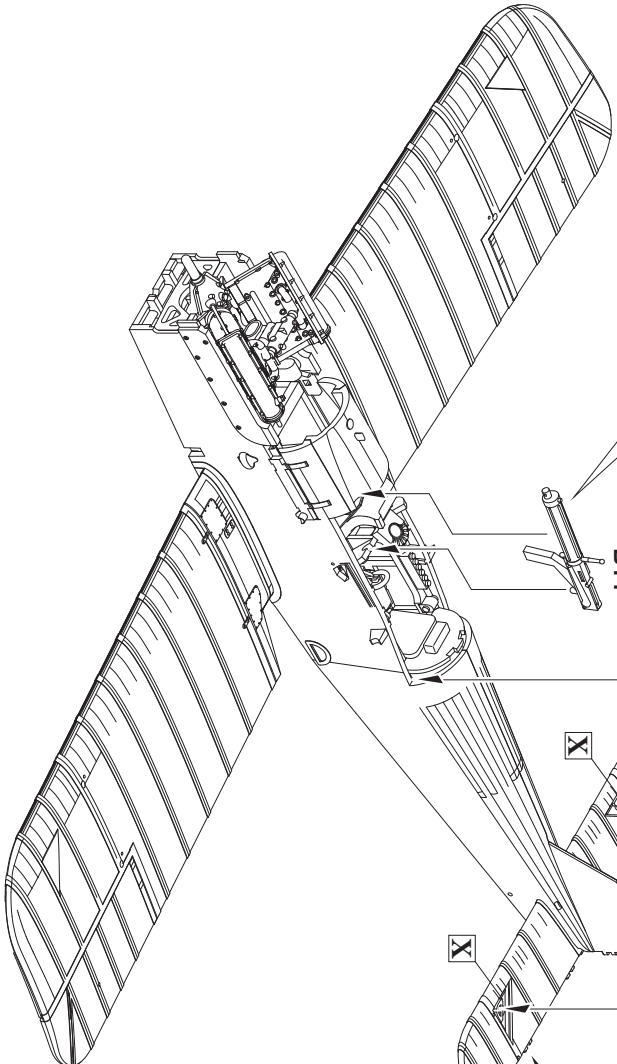



C2 - MARKINGS **B** **D**
C3 - MARKINGS **A** **C** **E**

PE22 ↻



C4, PE31 - MARKINGS **A** **B** **C** **E** ONLY

PE31

HT12
C33
FLAT BLACK



C4

PE17 ↻



fill

G

MC21B
BRASS

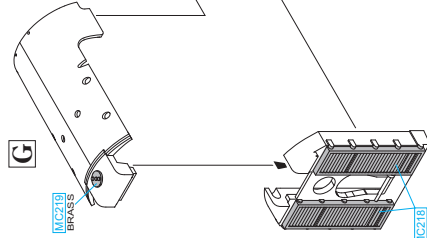

B17

MC21B
ALUMINIUM

B74 ?

B74 - MARKINGS **B** **D** ONLY

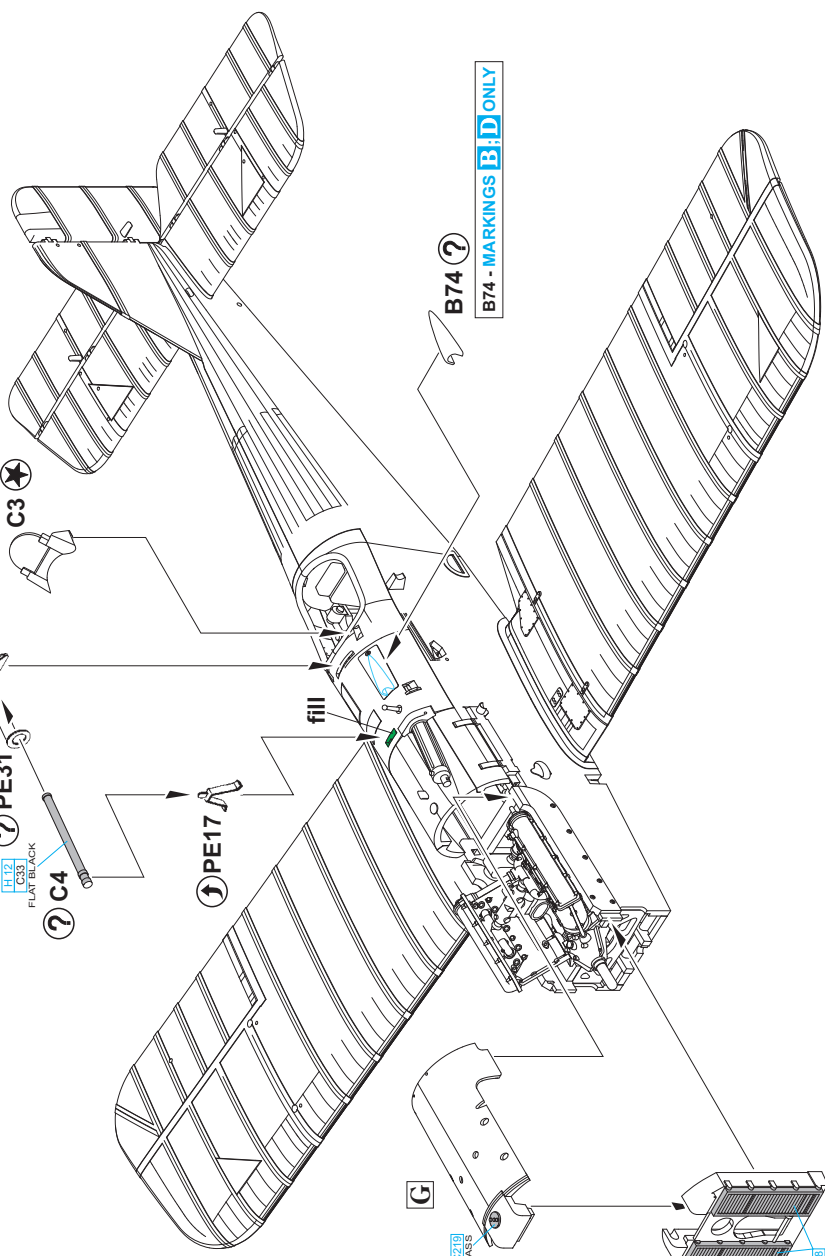

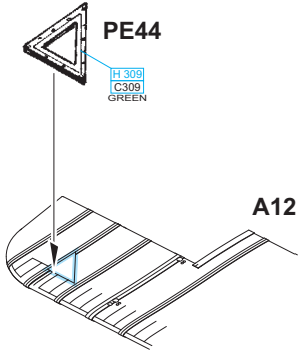
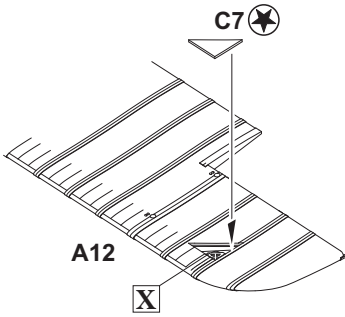
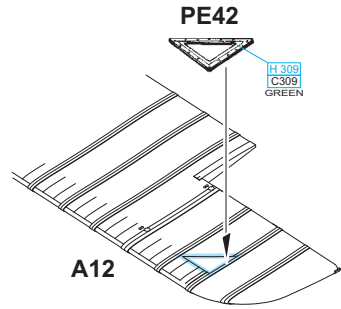
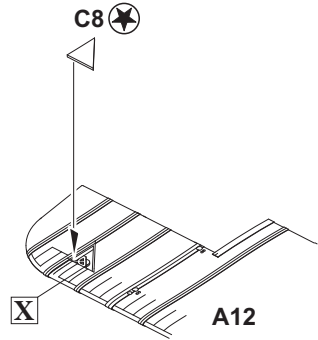
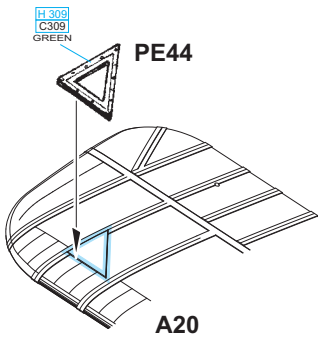
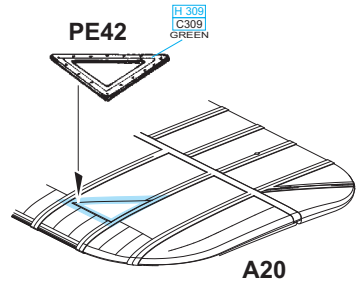
H**I****J****K**

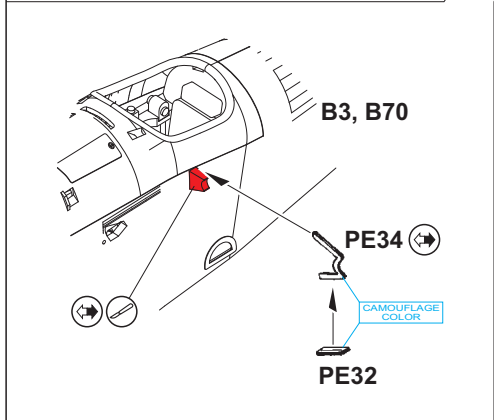
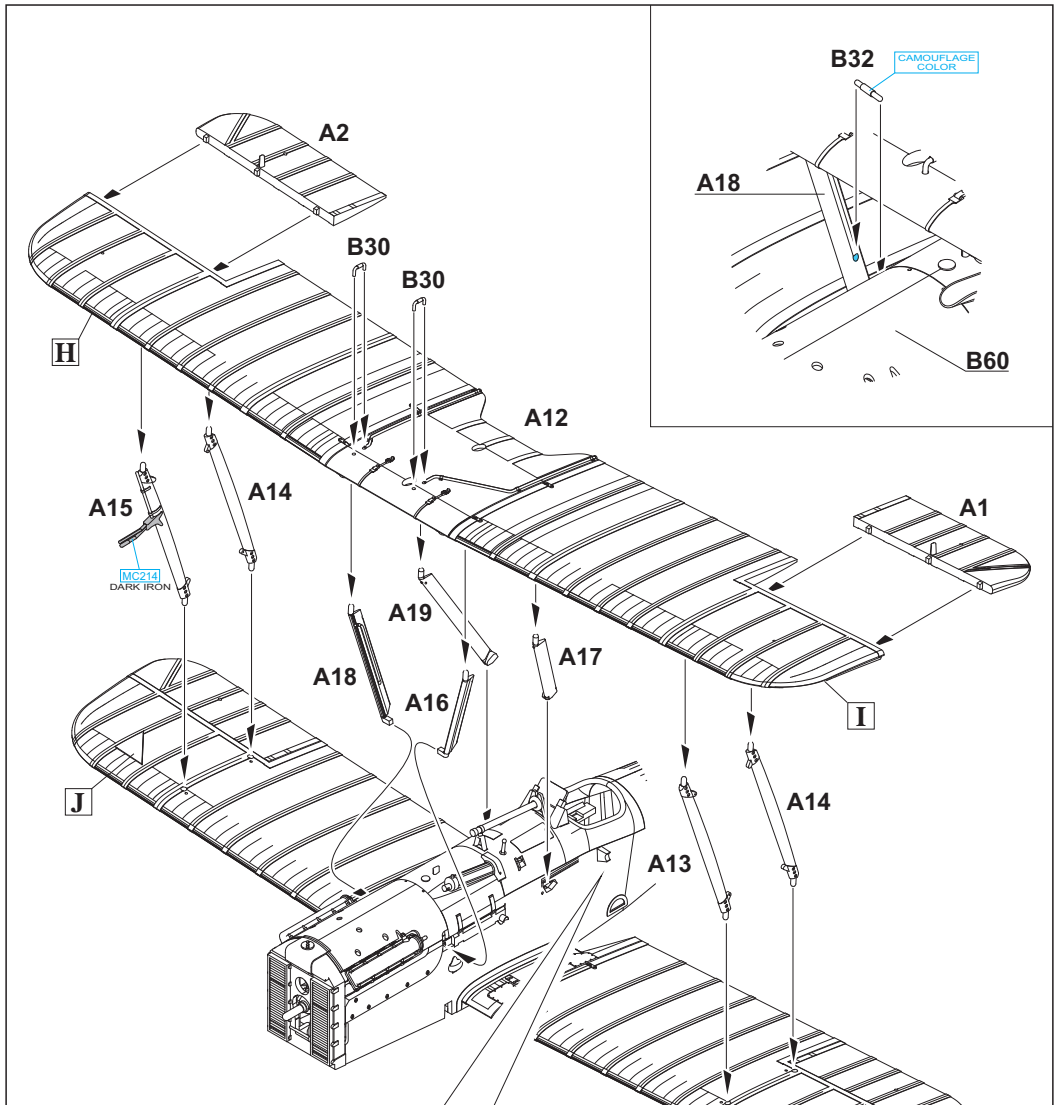

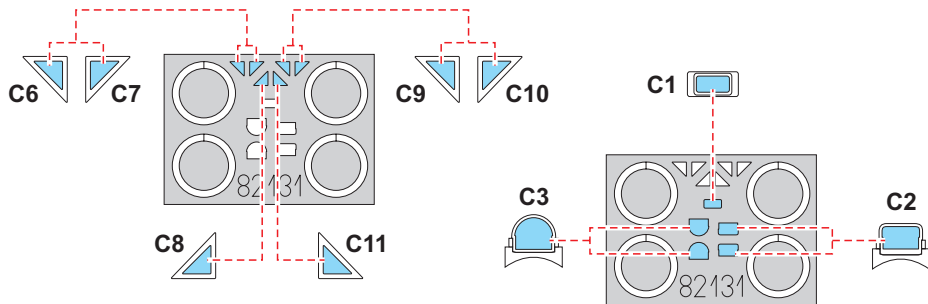
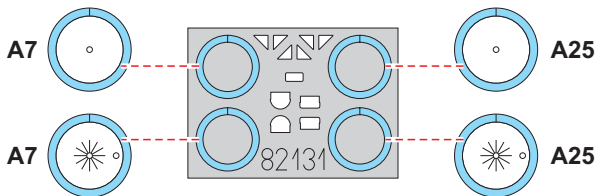

L

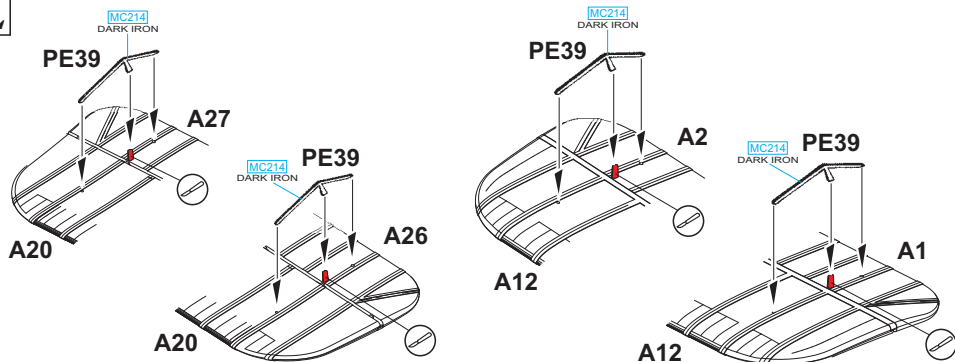

M

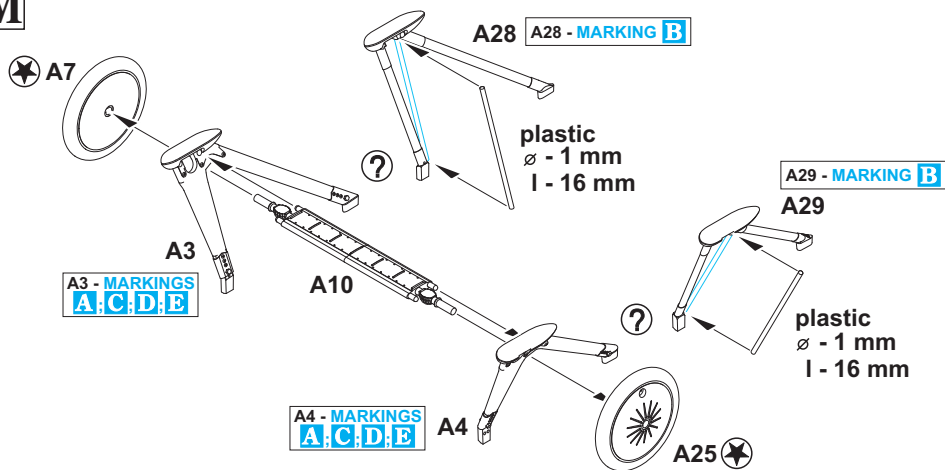

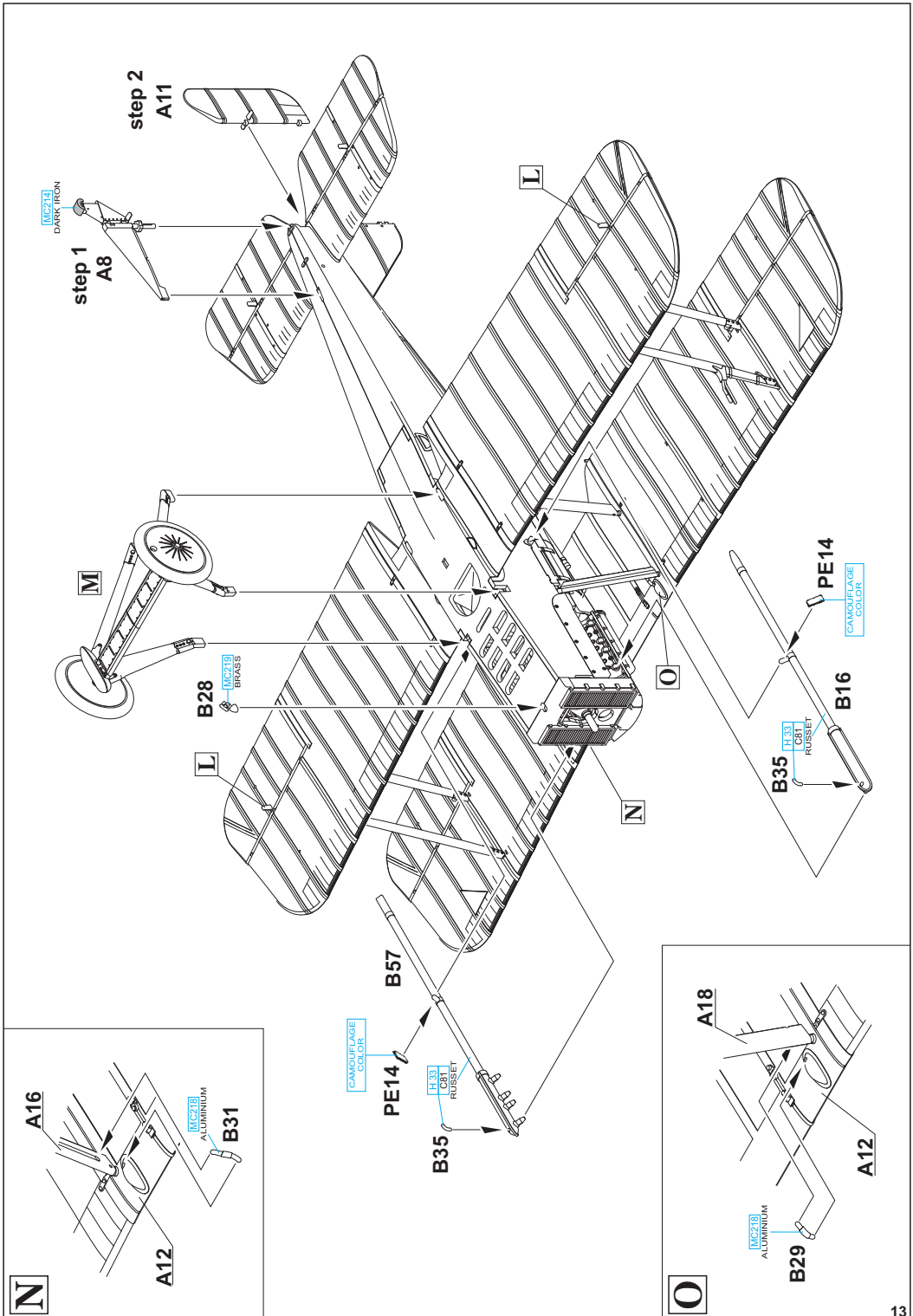

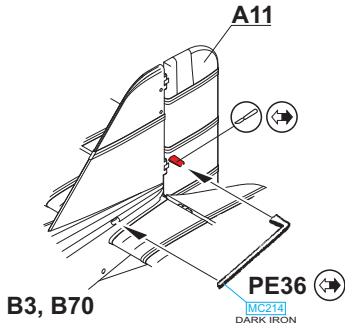
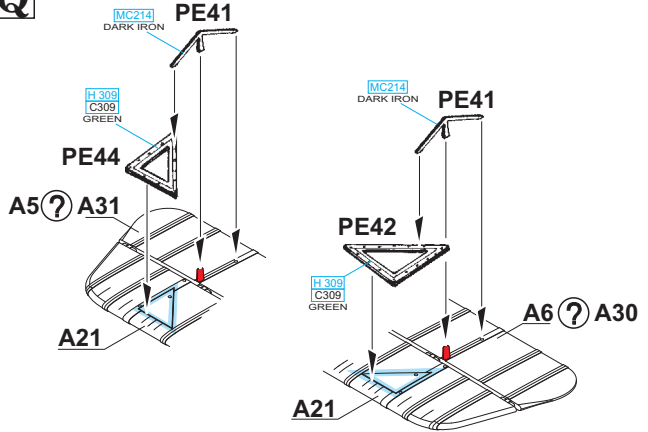
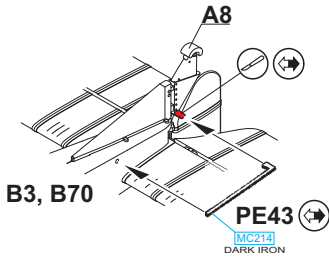
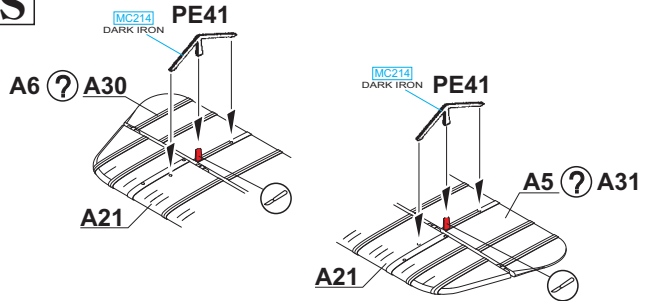
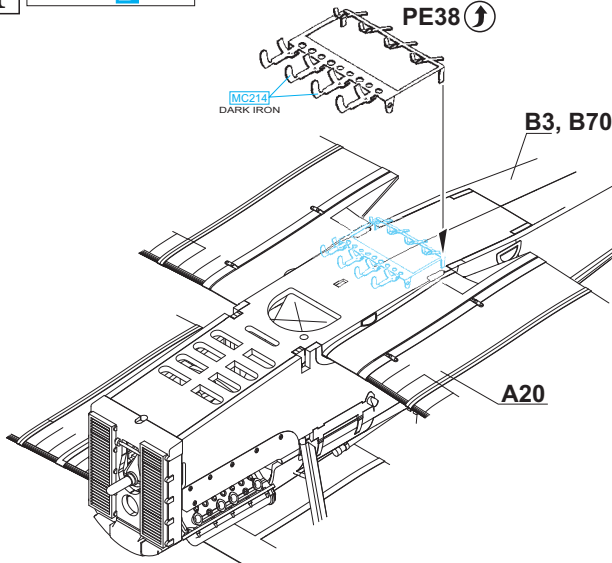
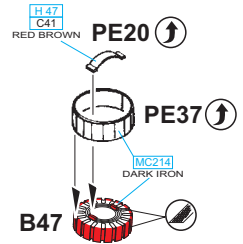
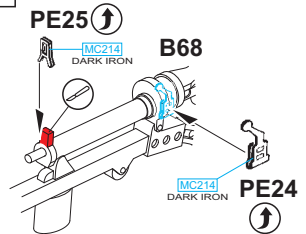
P**Q****R****S****T****MARKING B ONLY****U****V**

U B47

MC214
DARK IRON

B75

H37
C43
WOOD BROWN

B47, B68, B75 - MARKINGS
A, B, C, D ONLY

V B68

H37
C43
WOOD BROWN

A22 - MARKINGS
A, B, D ONLY

? A22

H47
C41
RED BROWN

L

Q

P

Q

? fill

MARKING E ONLY

L

B10

MC214
DARK IRON

S

R

S

T

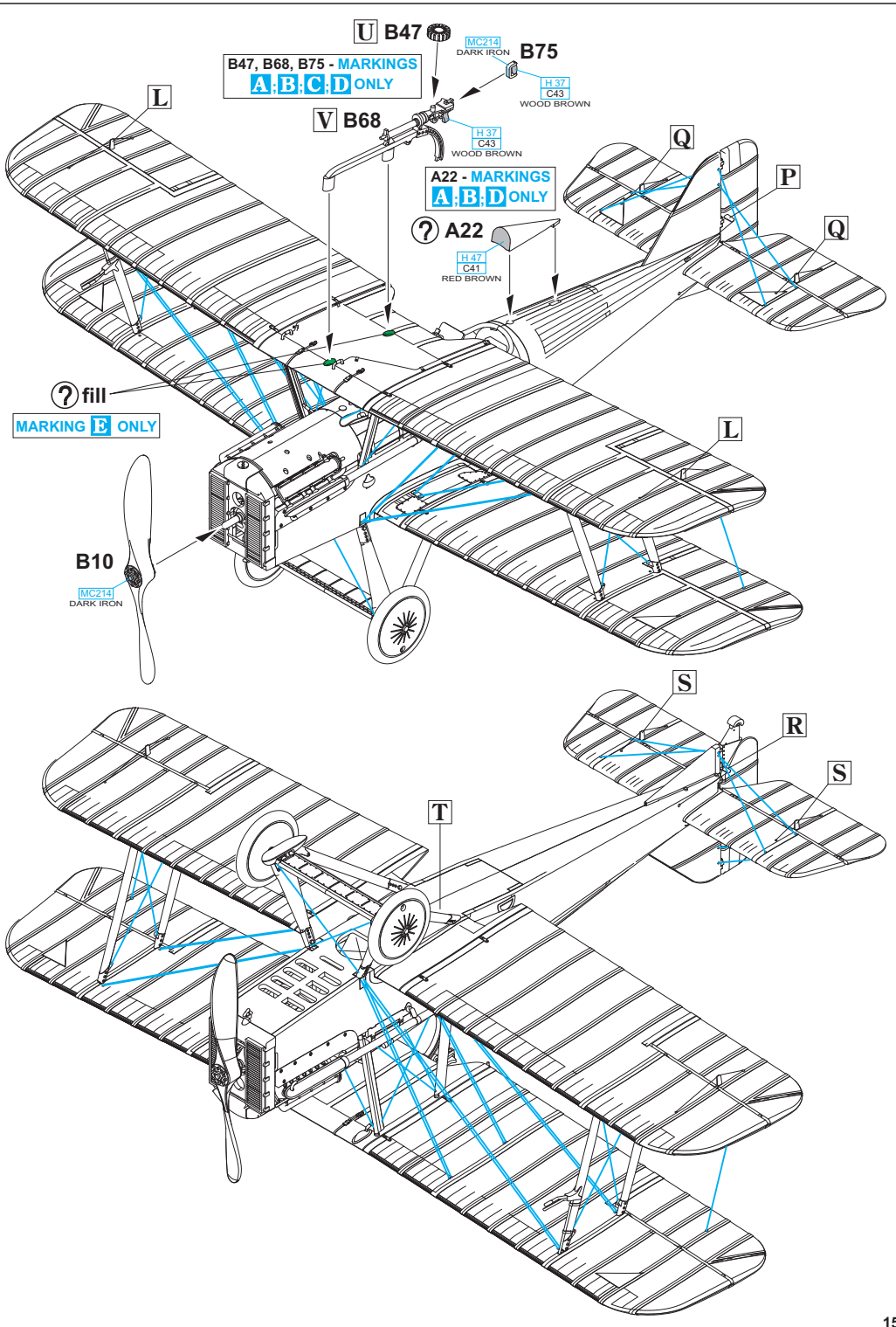

A C1096, Lt. H. J. Burden, No.56 Squadron, Valheureux, France, Spring 1918

The first Canadian fighter ace Henry John Burden was born on April 28th, 1894 in Toronto and his first taste of combat came in 1916 while with the Canadian Forestry Battalion in France. Originally, this unit was tasked with supplying wood as a strategic raw material to the British government. He joined the ranks of the RFC in April 1917, and after flight training he became a member of No.56 Squadron RFC in February 1918. The unit was equipped with the SE.5a. By the end of the war, he had 16 kills to his credit for which he was awarded the DSO and the DFC. White '3', which Lt. Burden flew at the begin of 1918, carried the standard british camouflage scheme. Upper and side surfaces were painted khaki PC 10. The bottom surfaces remained in the normal canvas colour. The PC 10 colour partially bordered along the lower surfaces. The first series SE.5a aircraft built for the RAF, of which this aircraft was a part, differed in the location of the national markings on the wings.

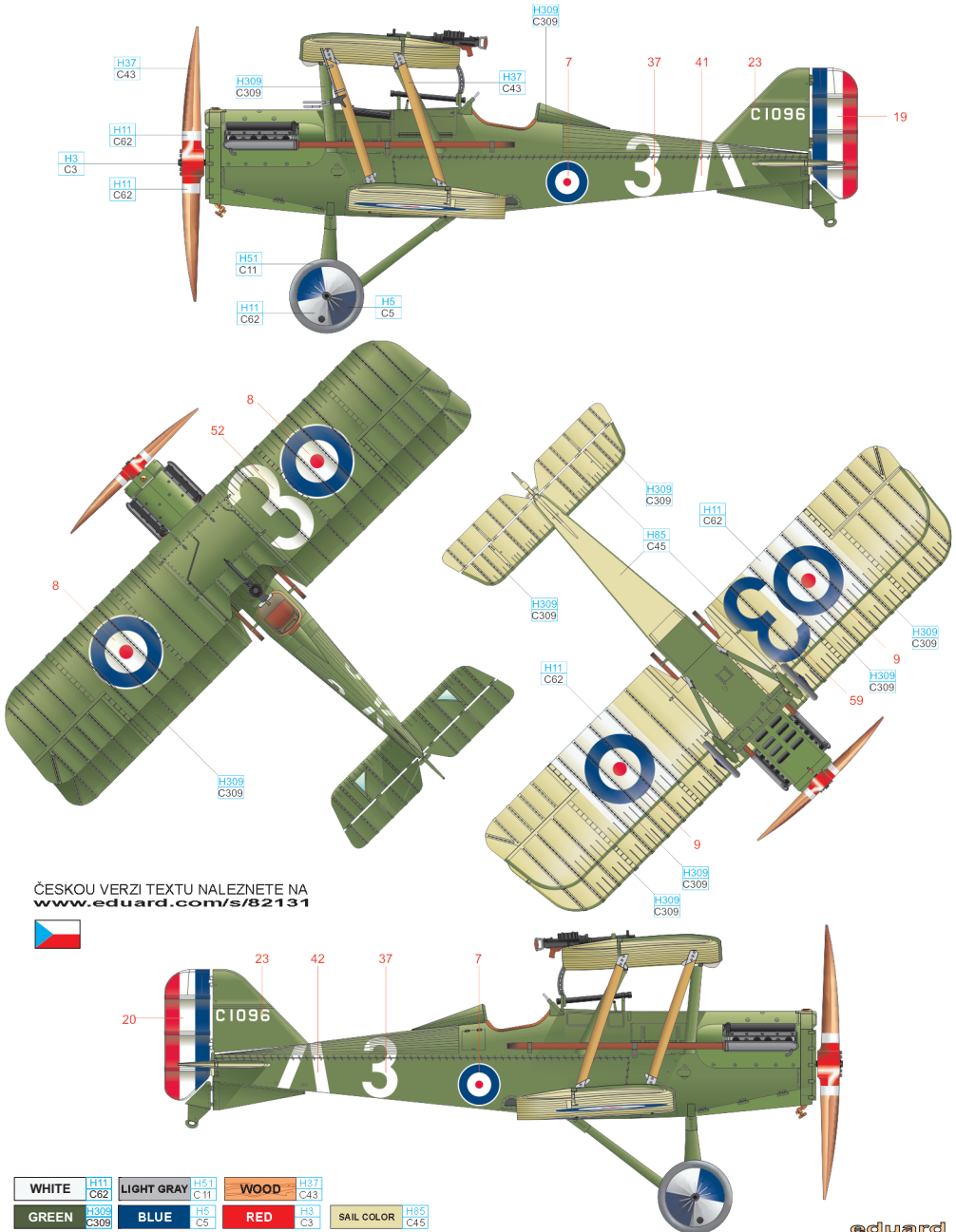

ČESKOU VERZI TEXTU NALEZNETE NA
www.eduard.com/s/82131



WHITE	H11 C62	LIGHT GRAY	H51 C11	WOOD	H37 C43
GREEN	H309 C309	BLUE	H5 C5	RED	H3 C3
				SAIL COLOR	H85 C45

B F8146, 27th Aero Squadron, United States, 1922

The 27th Aero Squadron was formed on May 8th, 1917 in Texas, and later moved to Toronto, Ontario, Canada to undergo training consistent with RFC norms. The unit arrived in France on March 18th, 1918 and began accumulating combat experience on June 2nd. The unit moved back to the States after the cessation of hostilities. Between 1919 and 1922, the unit was equipped with the SE.5a and the SE.5e. Later, the unit was redesignated as the 27th Fighter Squadron and operates as such to this day, flying the F-22, as the first unit to reach operation status using the type. Aircraft that were used in the United States had their upper surfaces painted Olive, and the lower surfaces received only a clear coat. The national insignia remained in the same location as the British markings. The white pointed star on a blue background with a red centre was worn by US aircraft from August 1919. The unit insignia appears behind the fuselage markings.

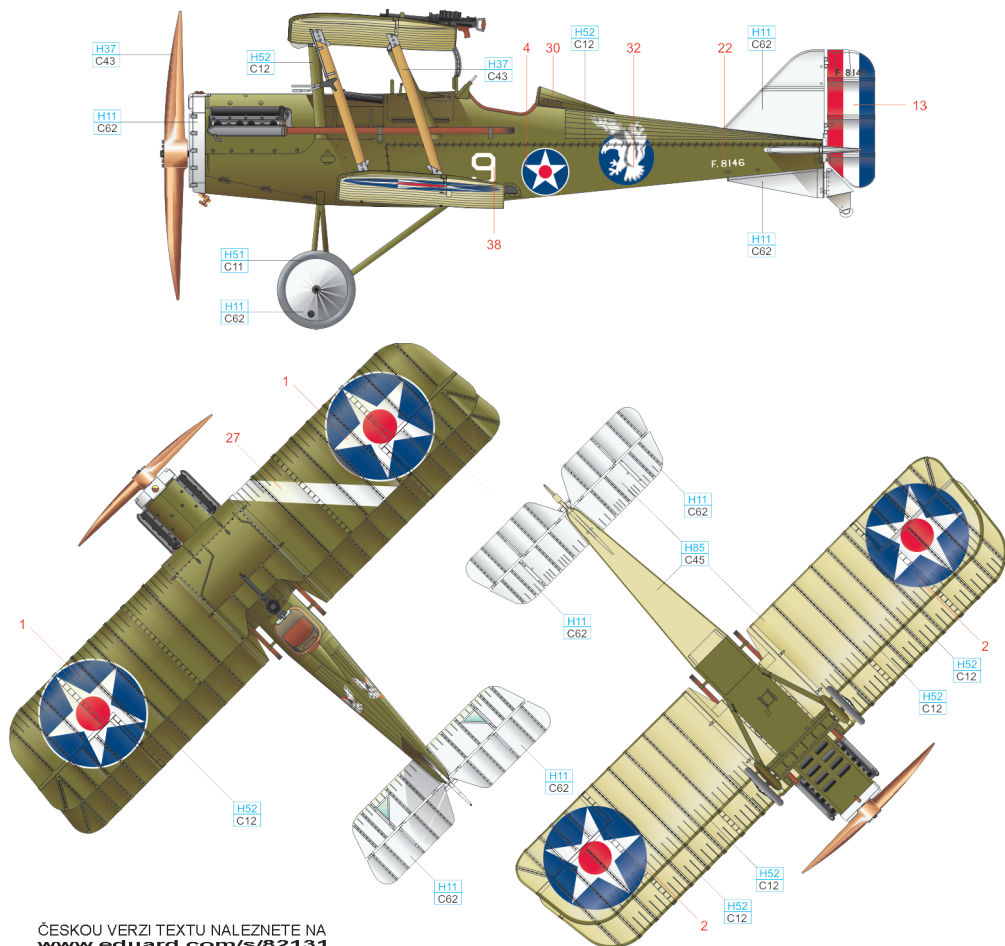

ČESKOU VERZI TEXTU NALEZNETE NA www.eduard.com/s/82131

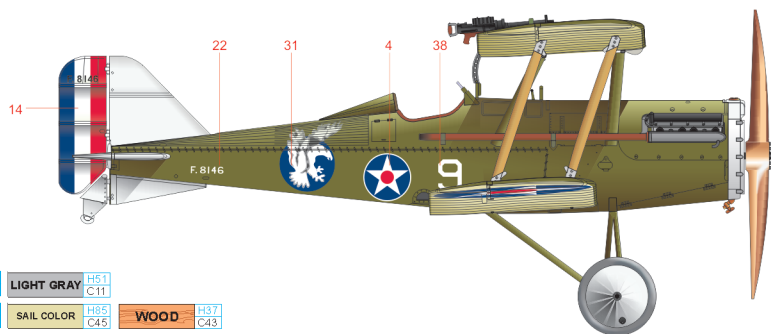

WHITE	H11 C62	LIGHT GRAY	H51 C11
OLIVE DRAB	H52 C12	SAIL COLOR	H85 C45
		WOOD	H37 C43

C F8953, 2nd Lt. S. C. Elliot, 85th Squadron, Ascq, France, December 1918

No.85 Squadron RFC was formed at Upavon in Great Britain on August 1st, 1917 and by May 1918, was moved to France and the midst of the fighting. Initially, the unit flew the Sopwith Dolphin and then re-equipped with the SE.5a. The aircraft flown by the Canadian Stuart C. Elliot was purchased with funds donated by the people of the town of Crieff, as indicated by the dedication inscription behind the roundel on the port side of the fuselage. The inscription partially obscures the markings of the 85th Squadron, a hexagon.

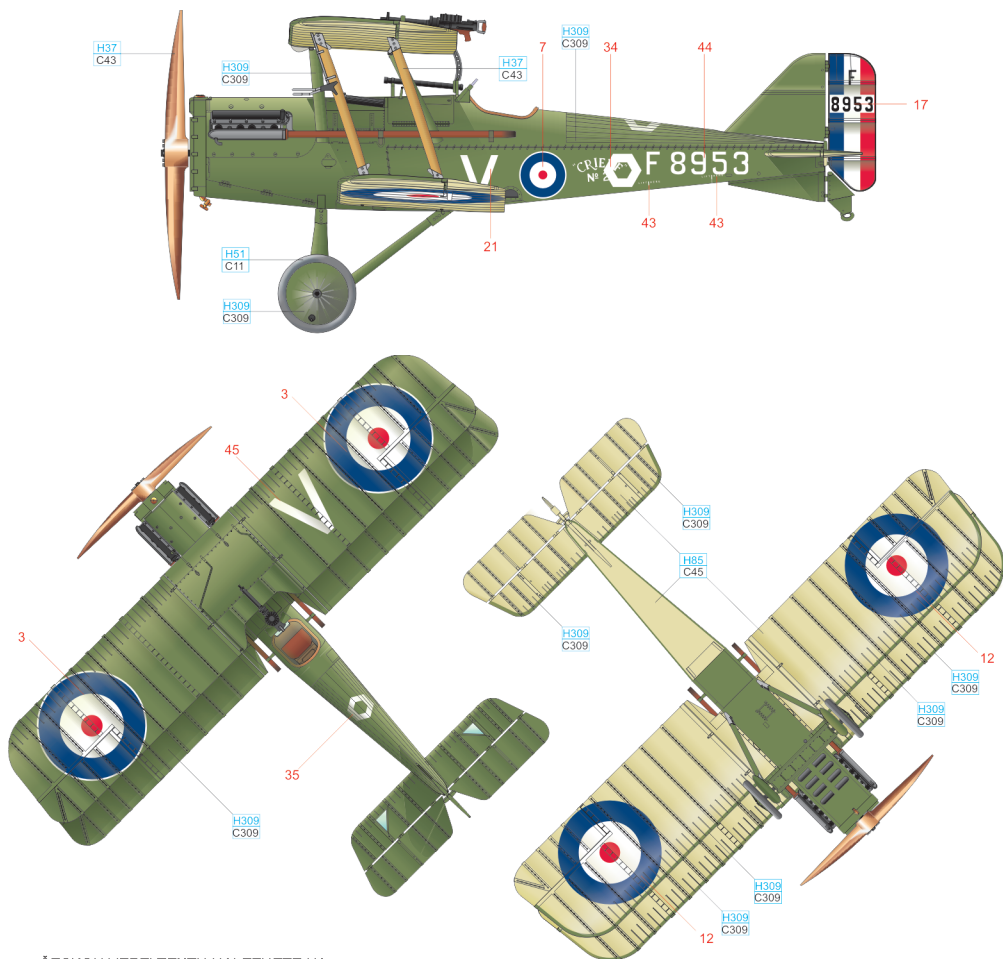

ČESKOU VERZI TEXTU NALEZNETE NA
www.eduard.com/s/82131

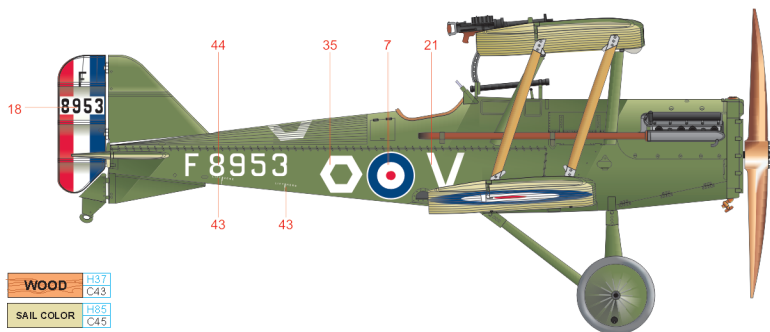

LIGHT GRAY	H51 C11	WOOD	H37 C43
GREEN	H309 C309	SAIL COLOR	H85 C45

E C1149, Capt. D. W. Grinnell-Milne, No.56 Squadron, Bethencourt, France, January 1919

British fighter ace Duncan William Grinnell-Milne was born on August 6th, 1896 in London and at the age of thirteen he joined the ranks of the 5th Battalion Rifle Brigade (Prince Consort's Own). After the beginning of the war, he was deemed too young for service at the Front, and was left on the island. He was subsequently assigned to the RFC and underwent pilot training. On September 29th, 1915 he received orders that assigned him to No.16 Squadron, RFC. As a member of this unit, he took part in the fighting, but on December 1st, 1916 he was shot down and taken prisoner. He managed to escape in April 1918 and return to the British side of the Front. After that, he was assigned to No.56 Squadron, equipped with the SE.5a. On December 17th, 1918 he was assigned CO of this unit. He had the fuselage of his SE.5a painted red and named it 'Schweinhund' as a reference to his time in German captivity.

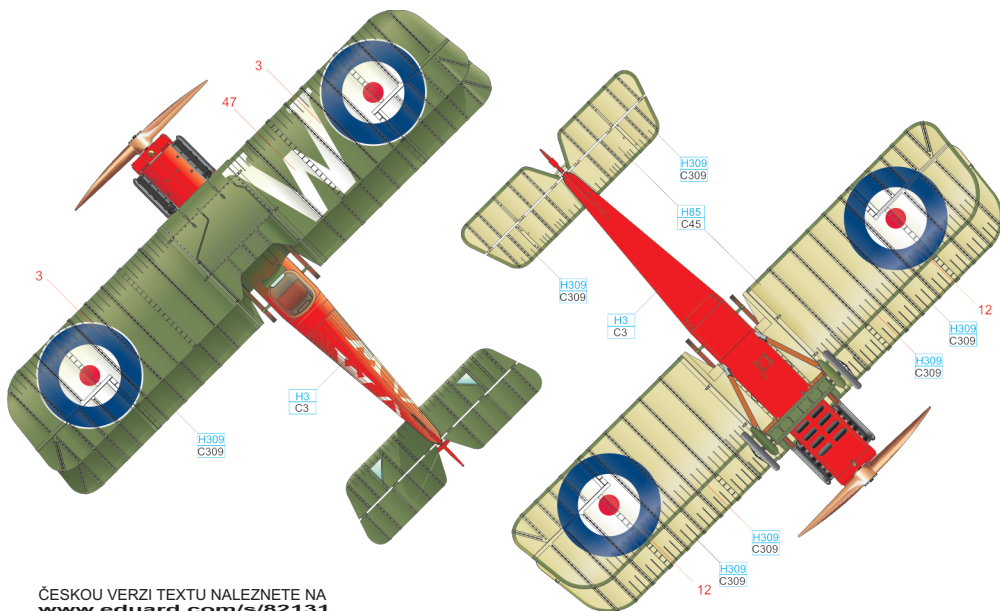
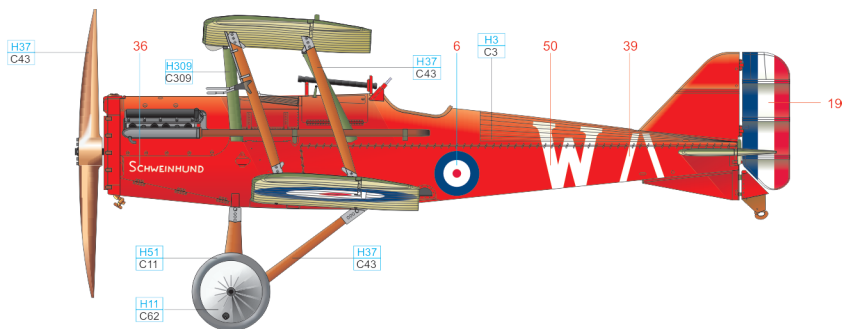

ČESKOU VERZI TEXTU NALEZNETE NA www.eduard.com/s/82131

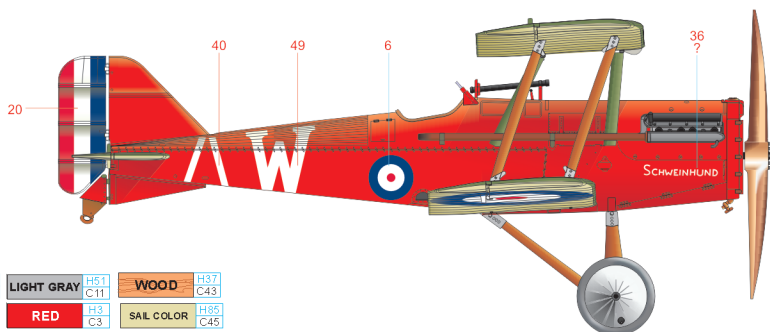

WHITE	H11 C62	LIGHT GRAY	H51 C11	WOOD	H37 C43
GREEN	H309 C309	RED	H3 C3	SAIL COLOR	H85 C45

eduard