

Fw 190A-5 light fighter

eduard

GERMAN WWII FIGHTER

1/48 SCALE PLASTIC KIT

ProfiPACK
edition

#82143



INTRO

The second half of the Second World War saw the Focke-Wulf Fw 190, in its various forms, emerge as the best of what was available to the Luftwaffe. The dedicated fighter version was a high performance, heavily armed machine. Its development had a precarious beginning, against a 1938 specification issued by the Technisches Amt, RLM. The first prototype took to the air on June 1st, 1939. After a series of improvements and even radical changes, the design culminated in the fall of 1940 in the pre-series version Fw 190A-0 to the tune of twenty-eight pieces. Six of these were retained by the test unit Erprobungsstaffel 190 at Rechlin, which was tasked with conducting service trials. These revealed a wide range of flaws to the point where the RLM halted further development. Despite this, on the basis of urgings from the test unit staff, the aircraft was not shelved. After a series of some fifty modifications, the RLM gave the go ahead for the Fw 190 to be taken into inventory of the Luftwaffe. In June 1941 the Luftwaffe accepted the first of 100 ordered Fw 190A-1s, armed with four 7.9 mm MG 17s. By September 1941 II./JG 26 was completely equipped with the type operating on the Western Front. November saw the production of the next version Fw 190A-2, powered by a BMW 801C-2, and armed with two 7.9 mm MG 17s and two MG 151s of 20 mm caliber in the wings. Part of this series received an additional pair of 20 mm MG FFs, thus attaining an armament standard of later types. A significant advancement to the design came in the spring 1942, when the BMW 801D-2 became available, whose installation gave birth to the Fw 190A-3. July saw the development of the improved A-4. Both were armed with what became the standard two fuselage mounted MG 17s, two wing mounted MG 151 cannons, and two MG FF cannons, placed inboard of the wheel wells. During 1942 production had intensified, and a production facility was set up under license at Fieseler. Thanks in part to this, production rose in 1942 to 1,878 units as opposed to 224 in 1941. Large-scale production of the A-5 was initiated in April 1943 with an identical wing to the A-4, but with a nose extension that would become standard on all subsequent Fw 190A versions up to the A-9, and also on the corresponding F types. July saw the development of a new, strengthened wing, which incorporated MG 151s instead of the MG FFs in the outer position. The adoption of this wing developed the A-6 version. Further changes developed the A-7, produced during the end of 1943. This version came about with the replacement of the fuselage mounted MG 17s with 13 mm MG 131s. Further improvements led to the Fw 190A-8, and this version became the most widely produced with some 6,655 units made. The most significant change to this variant was the installation of the GM-1 nitrous-oxide injection system, for temporary power boost in combat. A portion of A-8 production was built as the A-8/R2 and A-8/R8, armed with MK 108 cannon in the outer wing location, and with armoured slabs added to the cockpit sides and a modified canopy. The final production version of the BMW 801 powered fighter was the Fw 190A-9, equipped with the BMW 801TS of 2000 hp (1470 kW). There was a parallel development of these fighter optimized aircraft with a dedicated fighter-bomber version, the Fw 190F. These aircraft had reduced wing armament to two MG 151 cannons in the wing root position. The engine was optimized for low level operation, and the armament options varied to satisfy the ground attack role, including bombs of various weight classes and a variety of anti-tank rockets. This branched into the extended range Fw 190G version. Development of the throughbred fighter continued in the guise of the Fw 190D, which began to reach Luftwaffe units in the second half of 1944, and was the result of mounting an in-line Jumo 213A-1 engine into a modified Fw 190A-8 airframe. Although the Fw 190 never achieved the widespread usage of the competing Bf 109, its contribution to the German Air Force was certainly significant through the second half of WWII. Fw 190s saw service on the Western Front as well as in the East. As heavy fighters with imposing firepower, they found themselves integral components, from 1943 onwards, within the units tasked with the protection of the Reich from the ominous clouds of allied four-engined bombers. This is where the A-8 version was instrumental, along with its A-8/R2 armoured development. This version, with its firepower, was a very ominous and daunting foe for the bomber crews. From the second half of 1944, their danger was kept in check to a degree by escorting P-47s, and necessitated the development of the P-51 Mustang.

ATTENTION



UPOZORNĚNÍ



ACHTUNG



ATTENTION



注意



Carefully read instruction sheet before assembling. When you use glue or paint, do not use near open flame and use in well ventilated room. Keep out of reach of small children. Children must not be allowed to suck any part, or pull vinyl bag over the head.



Před započítím stavby si pečlivě prostudujte stavební návod. Při používání barev a lepidel pracujte v dobře větrané místnosti. Lepidla ani barvy nepoužívejte v blízkosti otevřeného ohně. Model není určen malým dětem, mohlo by dojít k požití drobných dílů.

INSTRUCTION SIGNS * INSTR. SYMBOL * INSTRUKTION SINNBILDEN * SYMBOLES * 記号の説明

OPTIONAL
VOLBABEND
OHNOUTOPEN HOLE
VYVRTAT OTVORSYMETRICAL ASSEMBLY
SYMETRICKÁ MONTÁŽREMOVE
ODŘÍZNOUTREVERSE SIDE
OTOČITAPPLY EDUARD MASK
AND PAINT
POUŽIT EDUARD MASK
NABARVIT

PARTS



DÍLY



TEILE



PIÈCES



部品

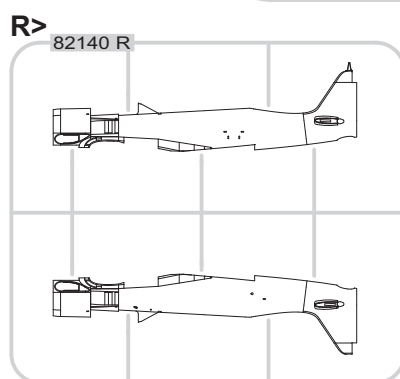
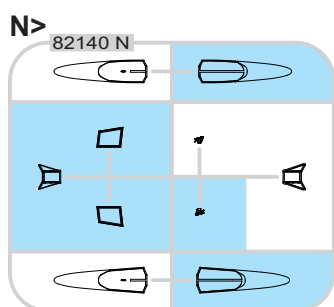
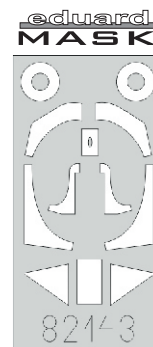
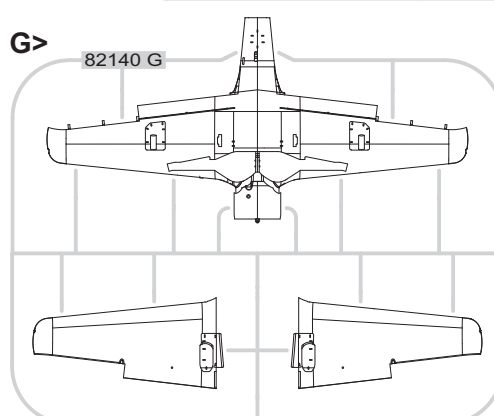
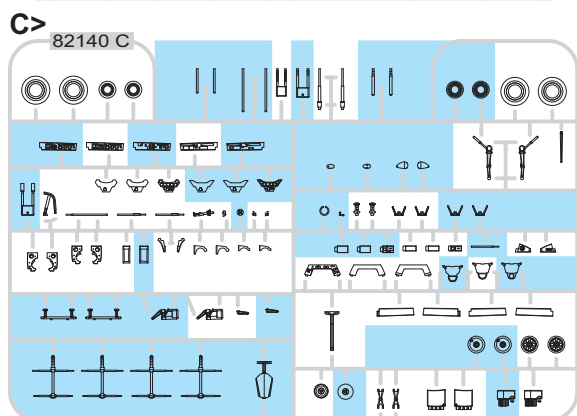
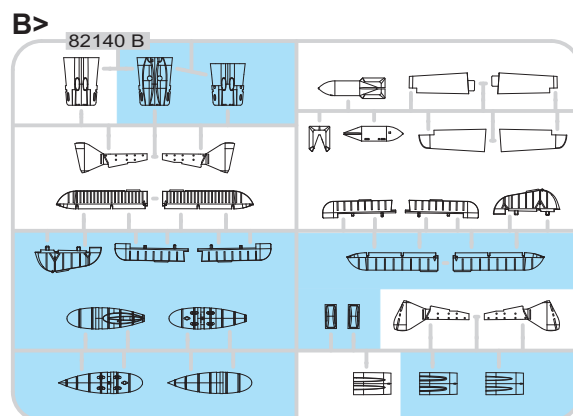
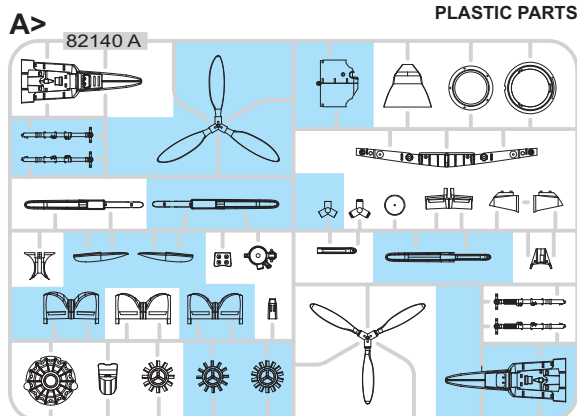

PE - PHOTO ETCHED DETAIL PARTS

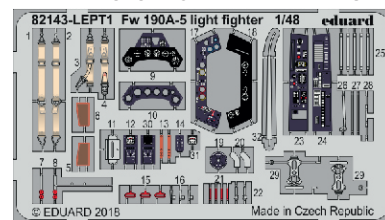

-Parts not for use. -Teile werden nicht verwendet. -Pièces à ne pas utiliser. -Tyto díly nepoužívejte při stavbě. - 使用しない部品

COLOURS



BARVY



FARBEN



PEINTURE



色

GSi Creos (GUNZE)		
AQUEOUS	Mr.COLOR	
H1	C1	WHITE
H2	C2	BLACK
H11	C62	FLAT WHITE
H12	C33	FLAT BLACK
H33	C81	RUSSET
H47	C41	RED BROWN
H65	C18	RLM70 BLACK GREEN
H68	C36	RLM74 DARK GRAY
H69	C37	RLM75 GRAY
H70	C60	RLM02 GRAY
H77	C137	TIRE BLACK
H80	C54	KHAKI GREEN

AQUEOUS	Mr.COLOR	
H90	C47	CLEAR RED
H94	C138	CLEAR GREEN
H303	C303	GREEN
H304	C304	OLIVE DRAB
H413	C113	RLM04 YELLOW
H414	C114	RLM23 RED
H416	C116	RLM66 BLACK GRAY
H417	C117	RLM76 LIGHT BLUE
Mr.METAL COLOR		
	MC213	STEEL
	MC214	DARK IRON
Mr.COLOR SUPER METALLIC		
	SM06	CHROME SILVER

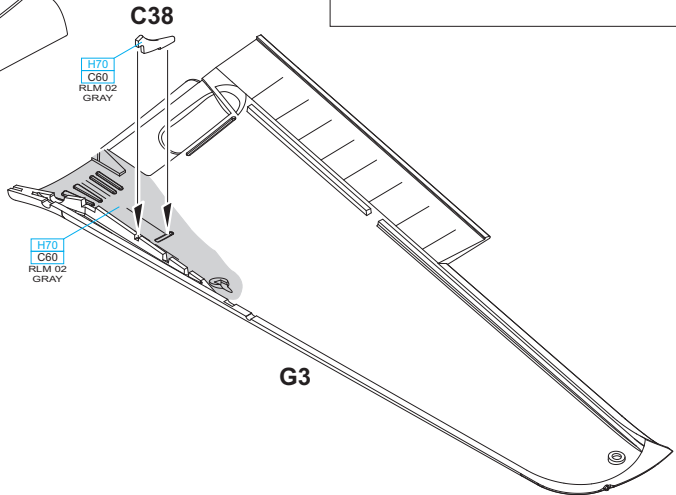
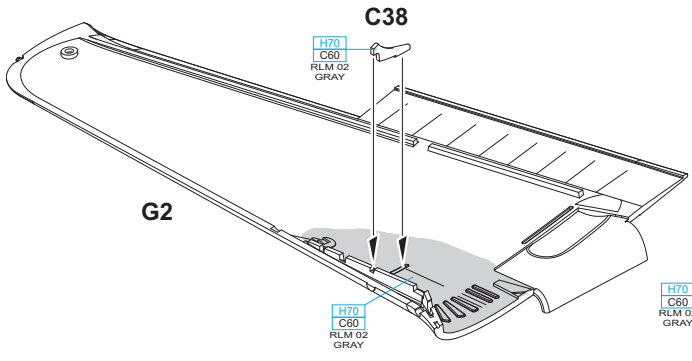
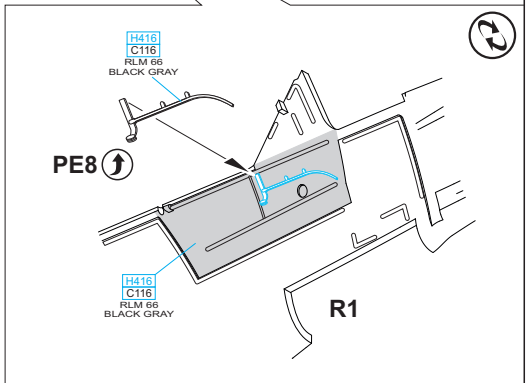
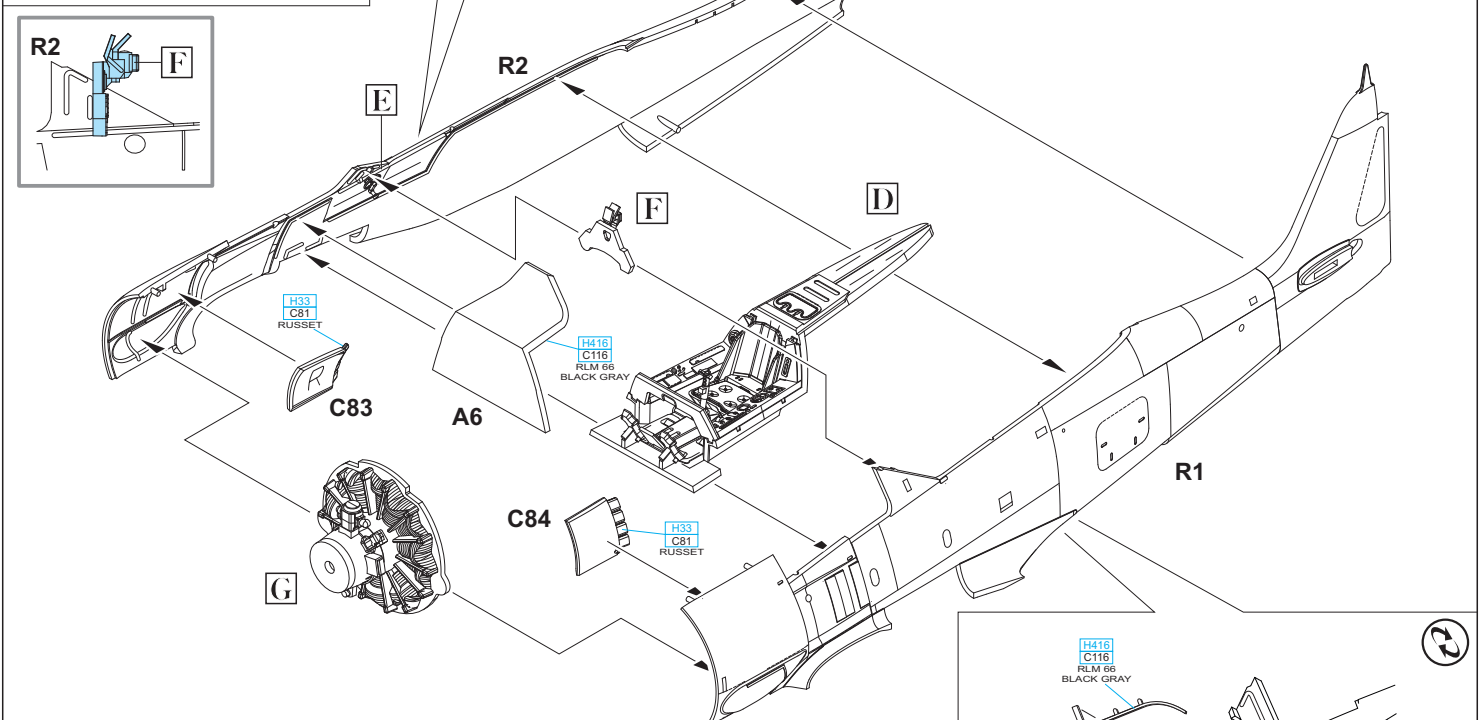
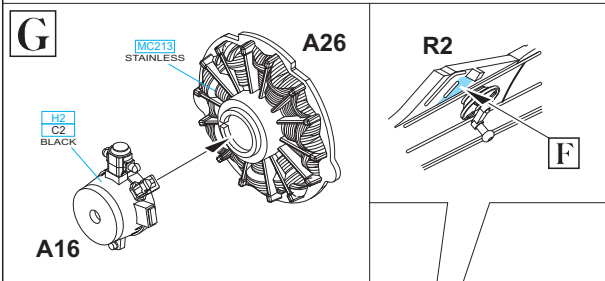
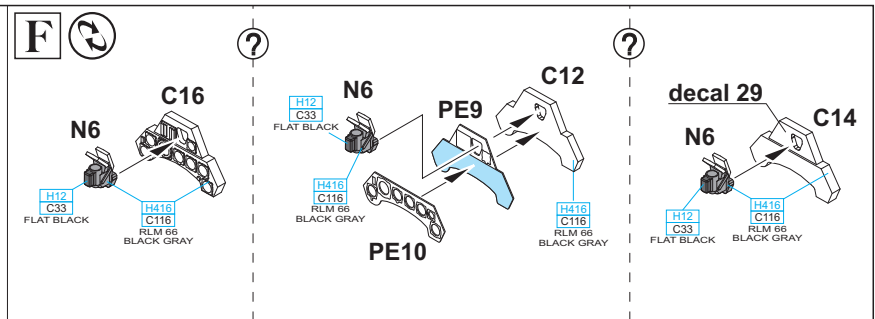
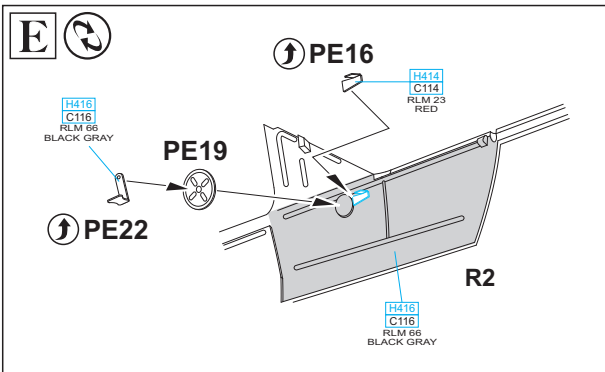

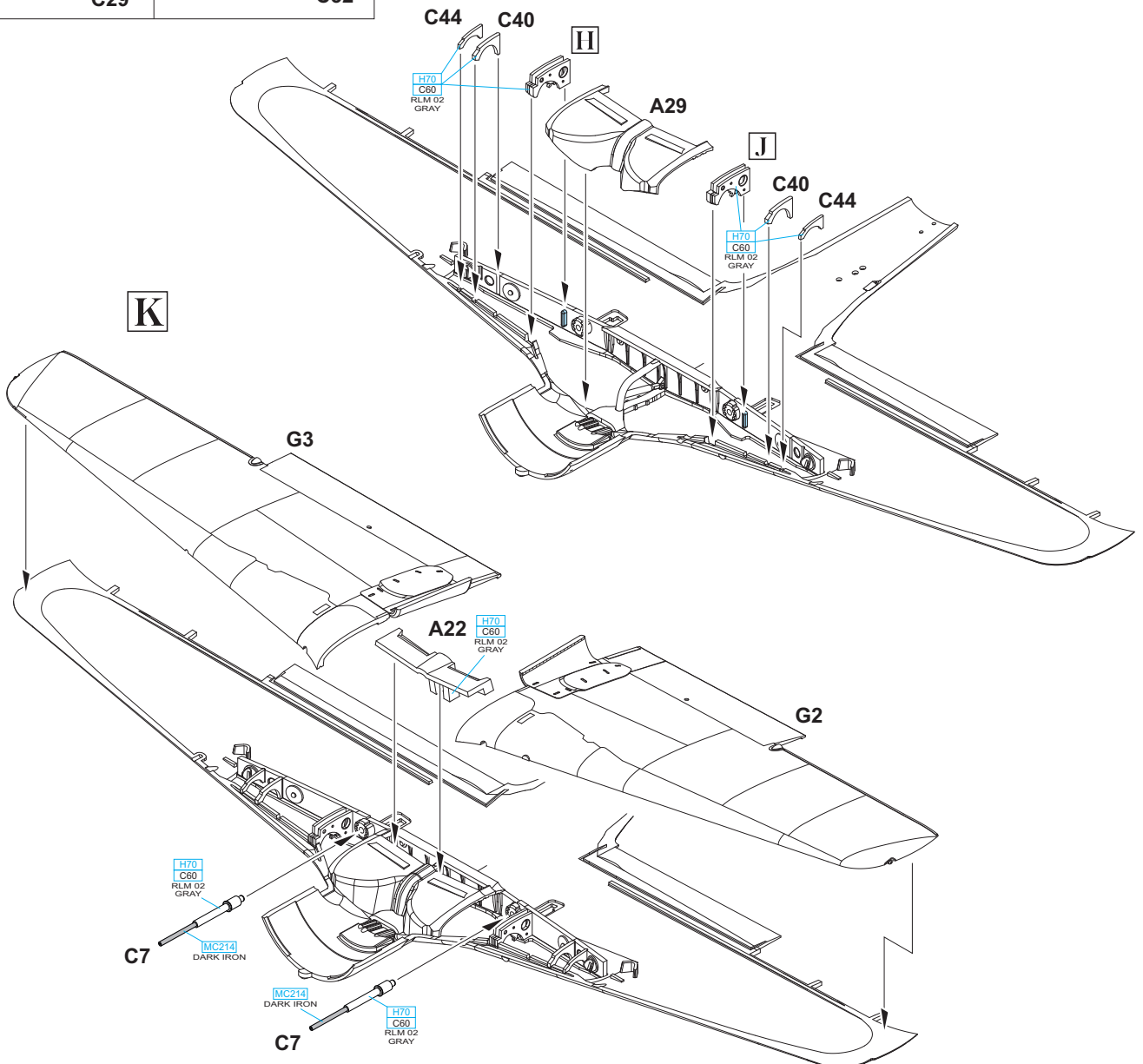
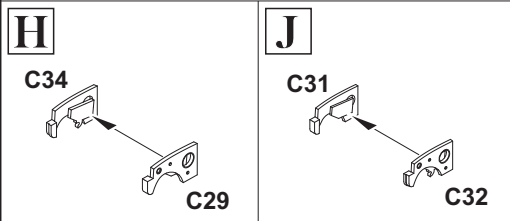
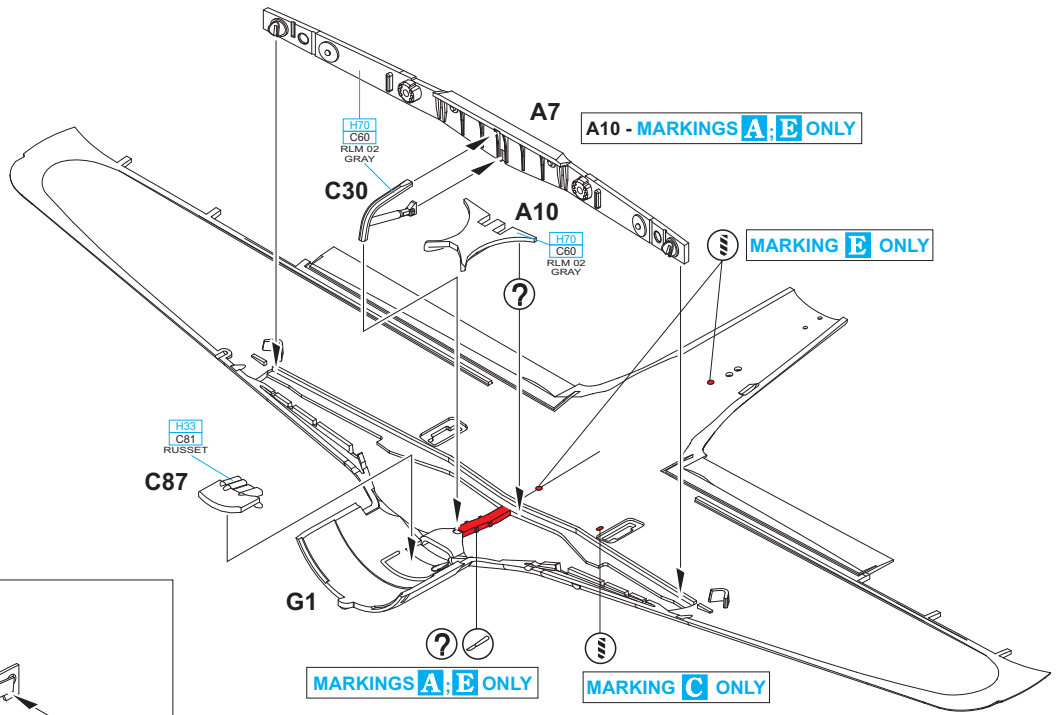

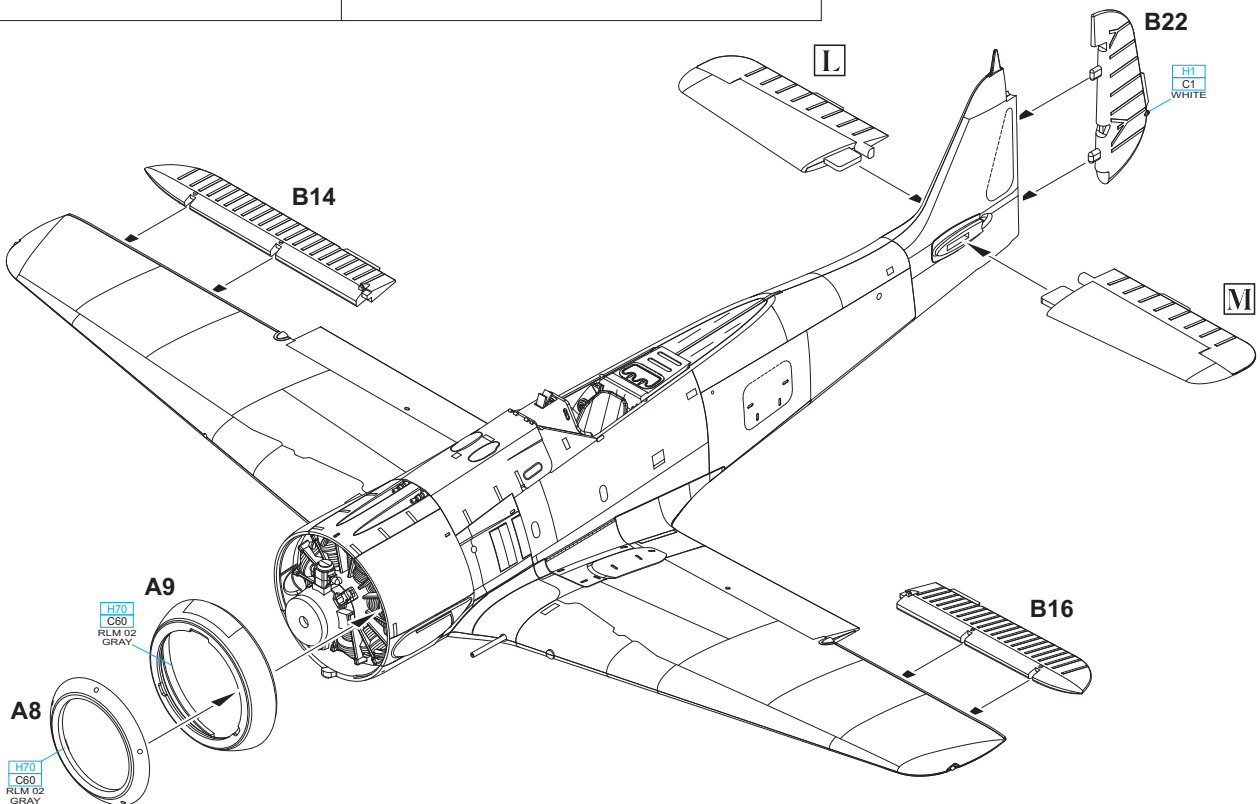
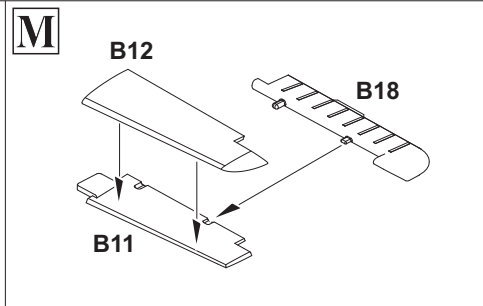
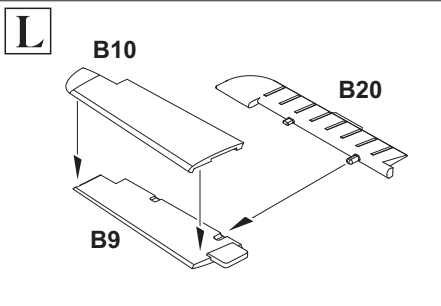
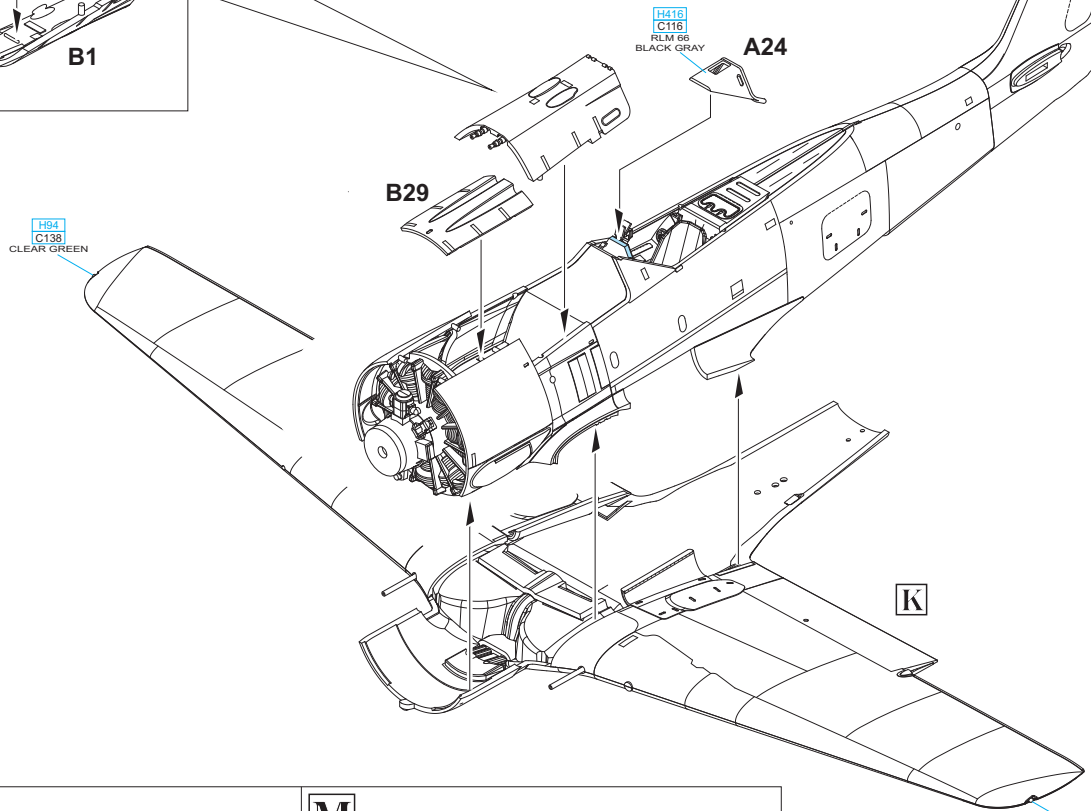
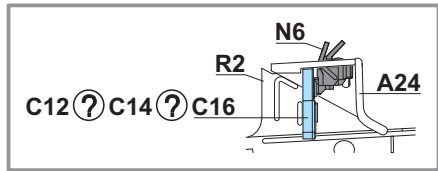
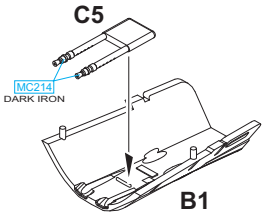

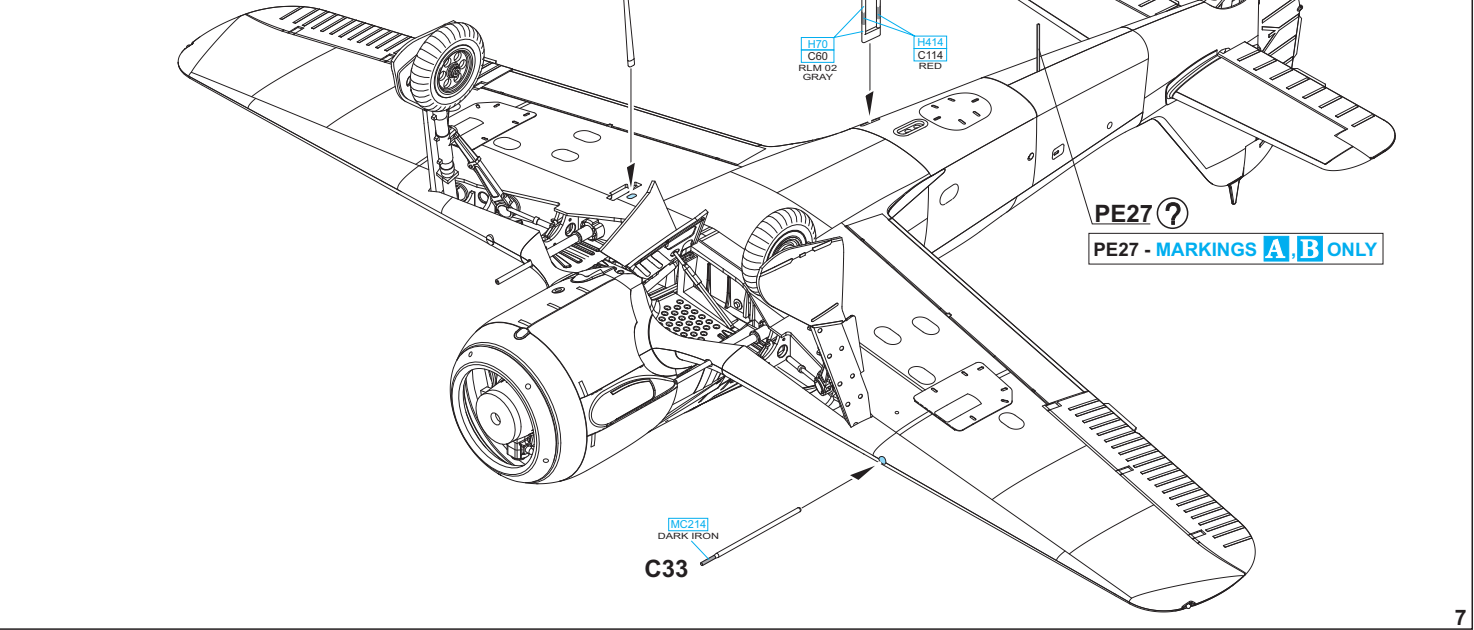
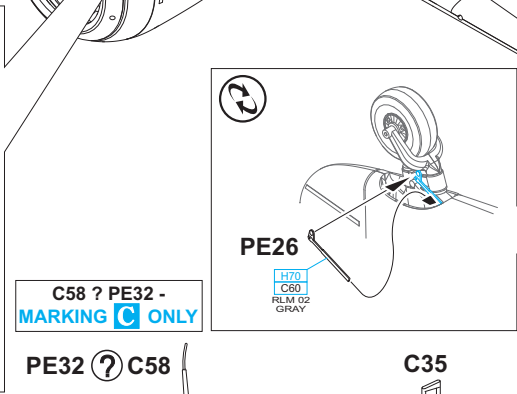
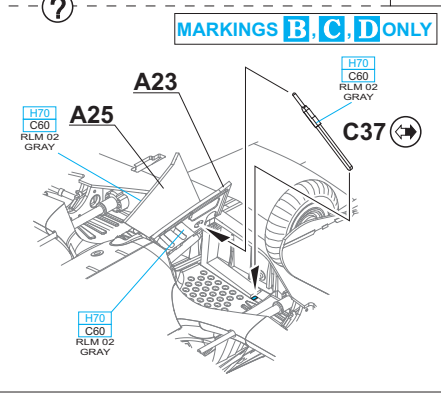
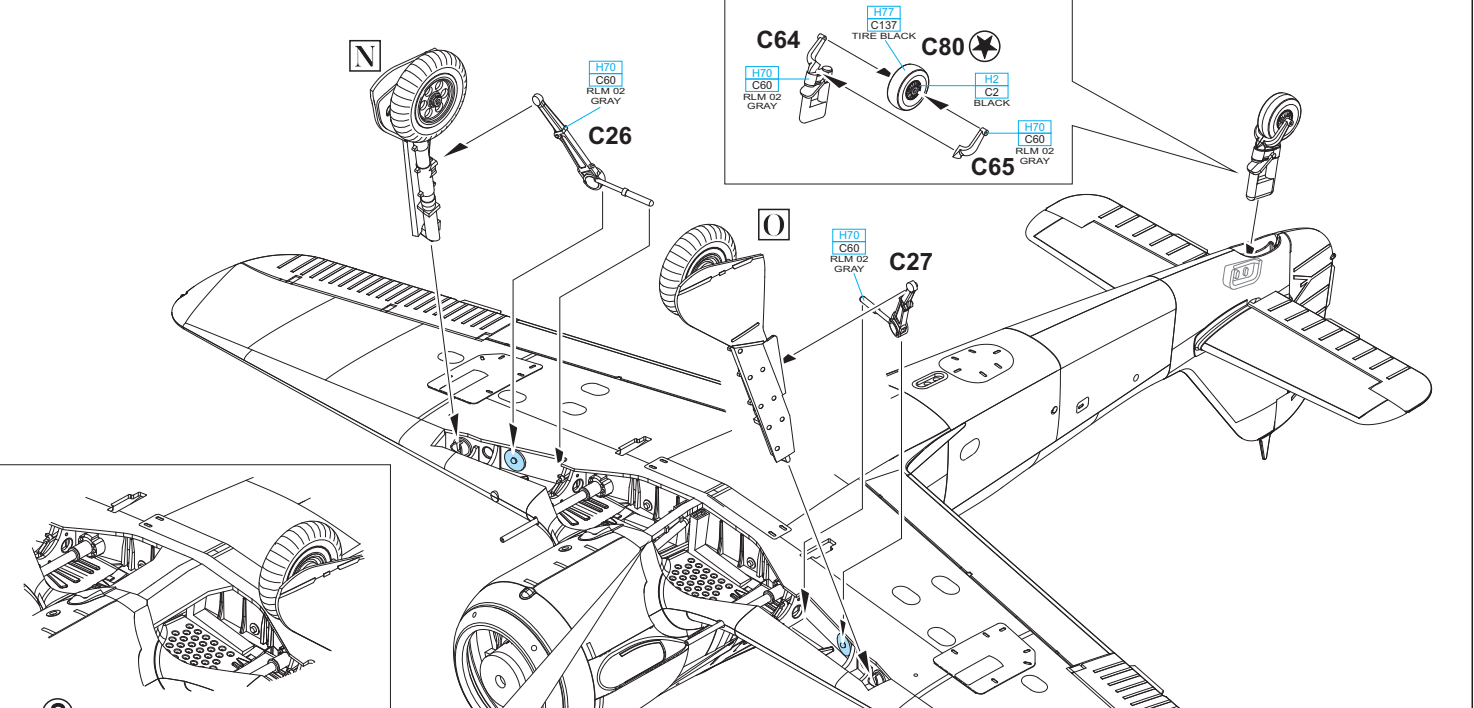
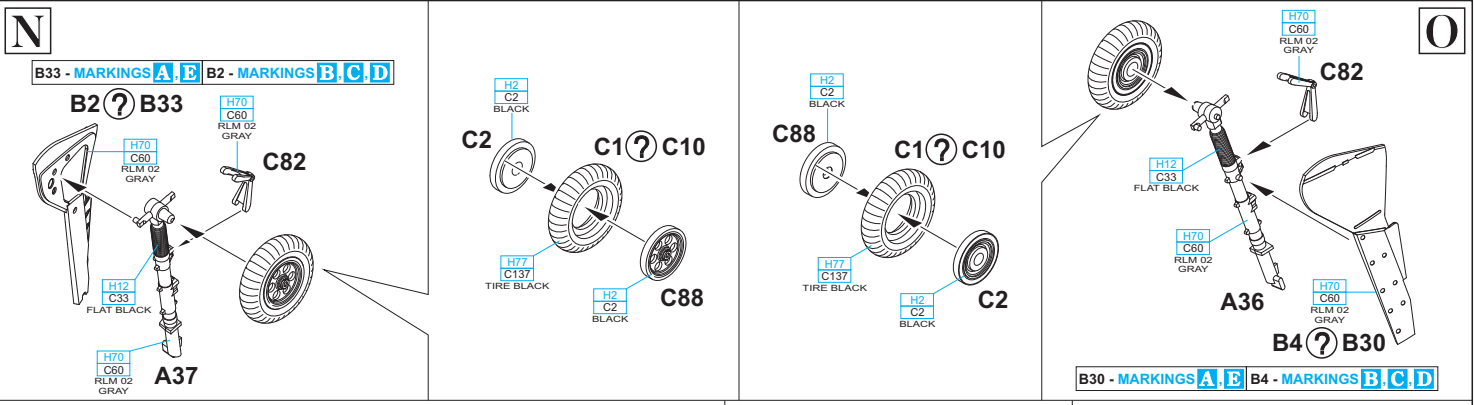

P

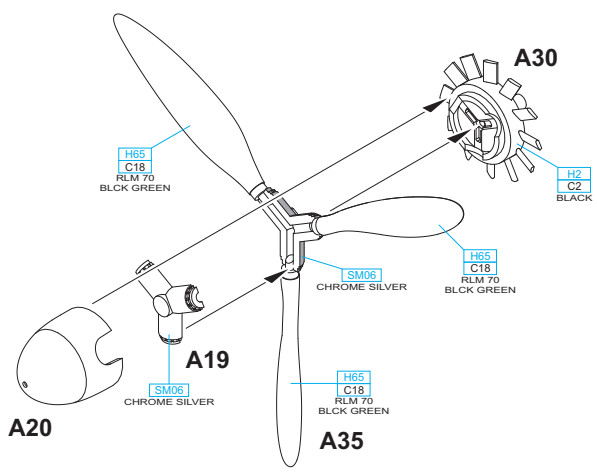

Q

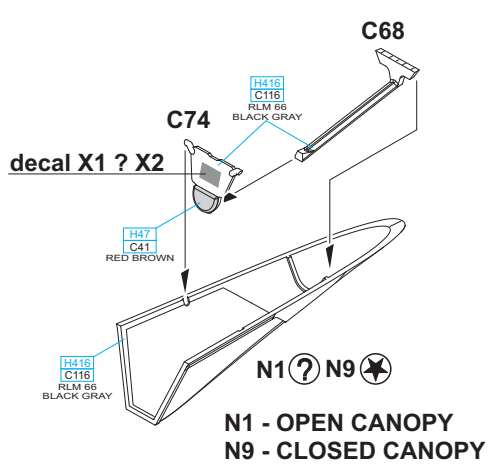

OPEN CANOPY

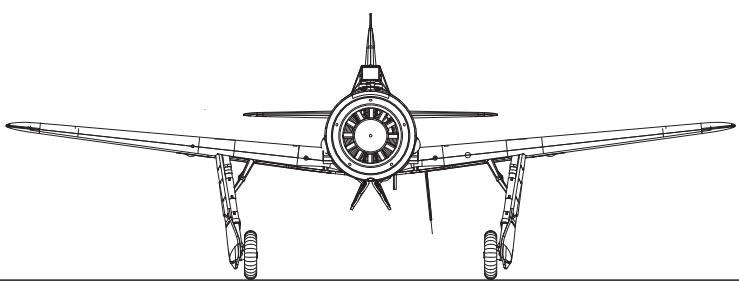
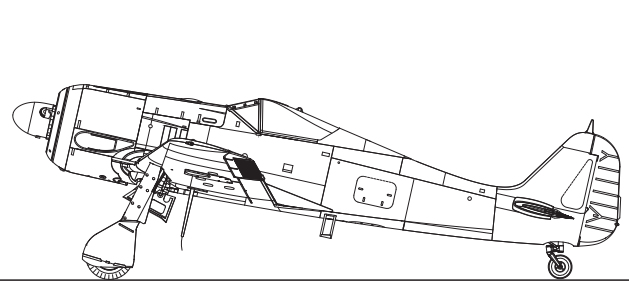
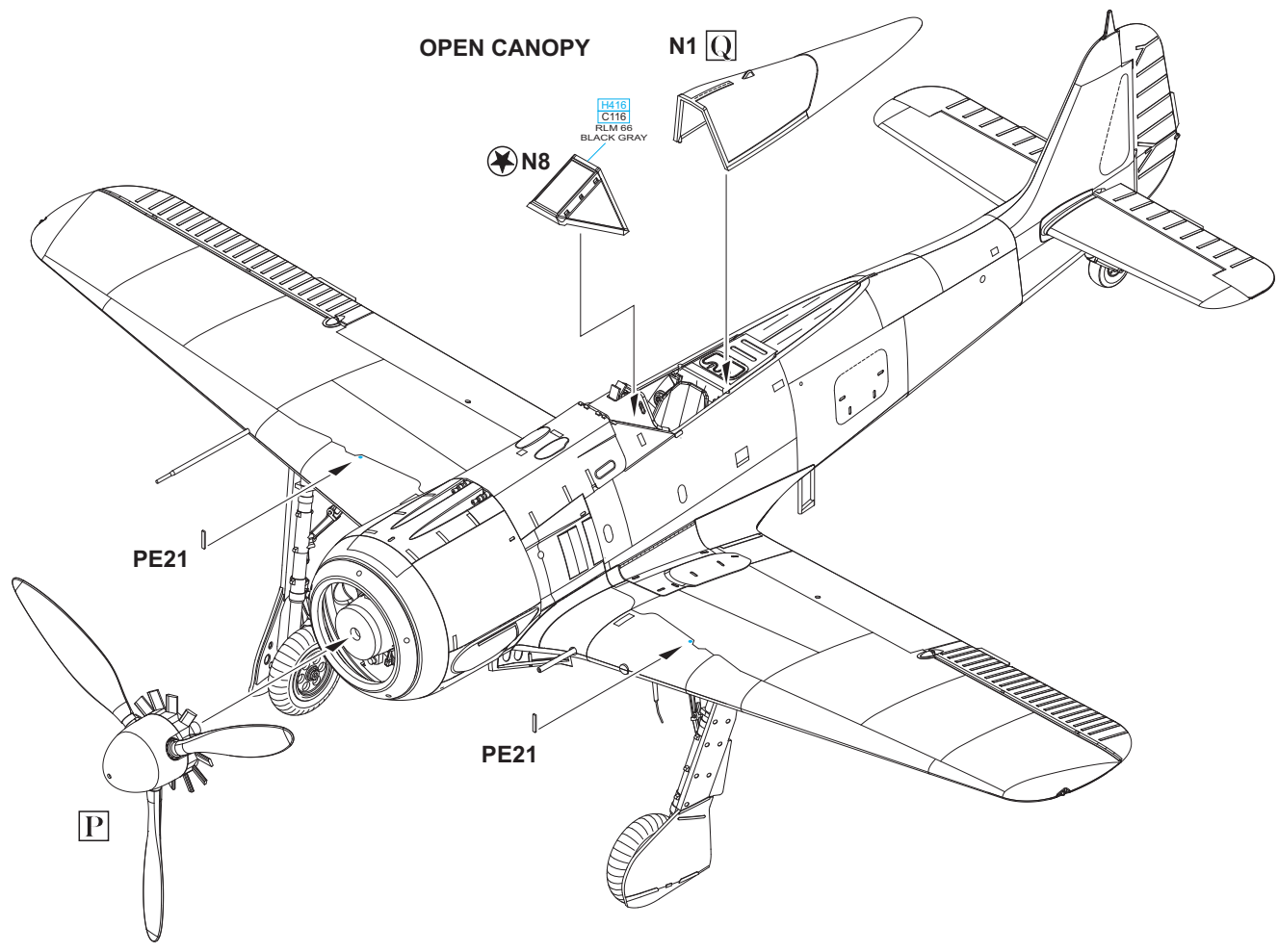

CLOSED CANOPY

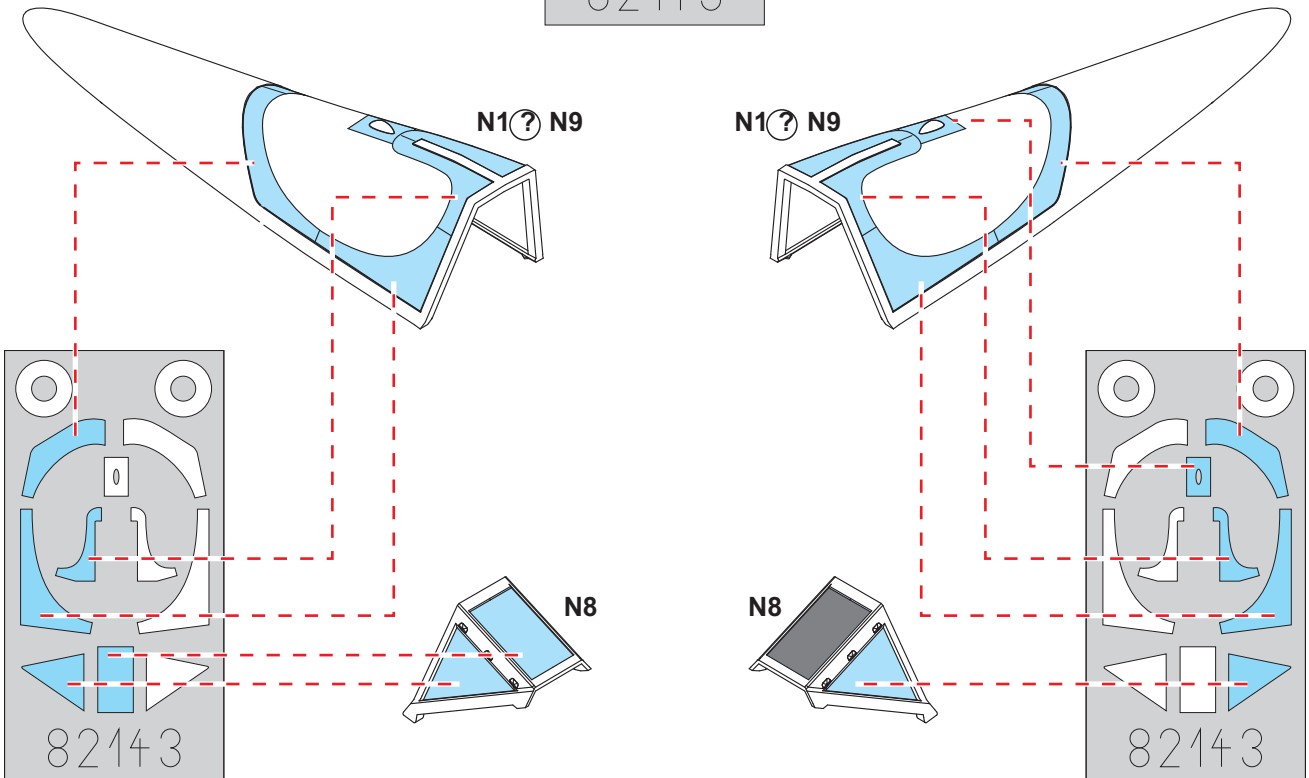
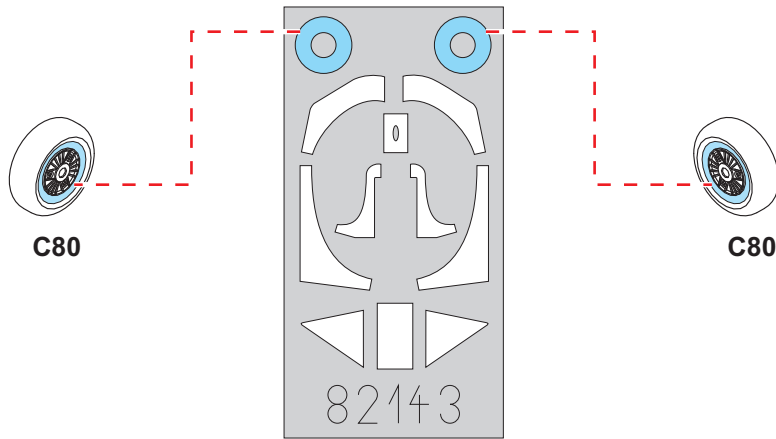
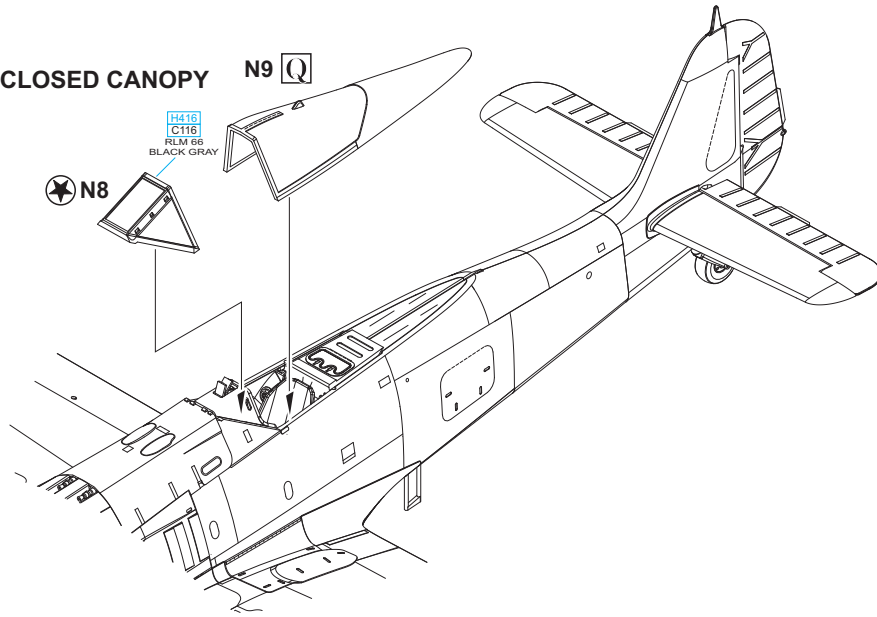

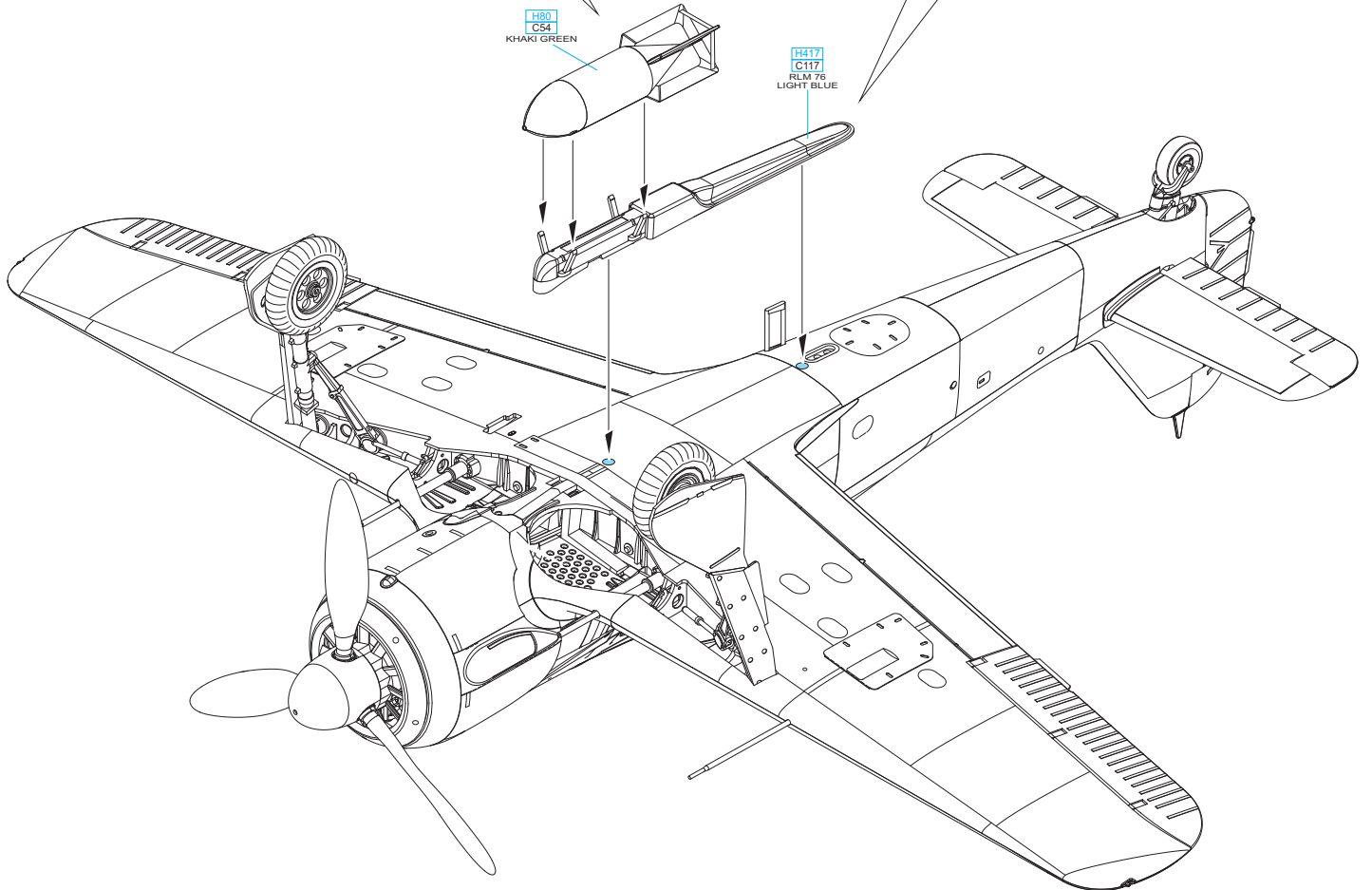
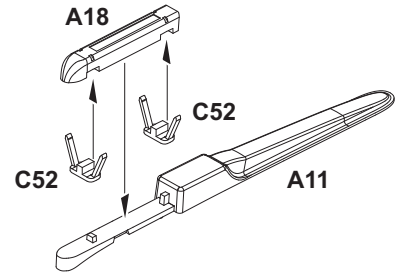
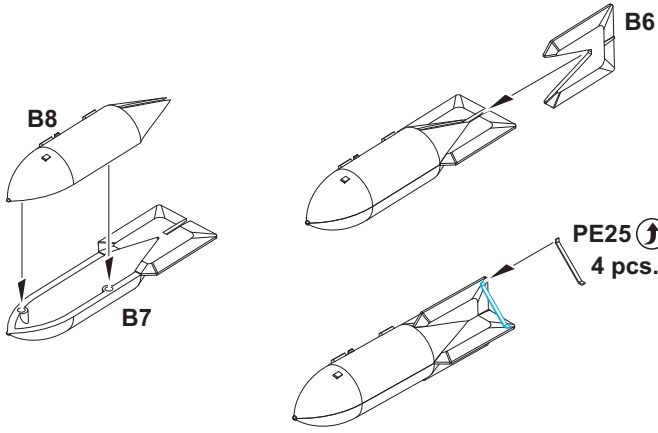

Josef "Pips" Priller was born on July 27th, 1915 in Ingolstadt, Bavaria. In 1935, he joined Wehrmacht, and as soon as one year later, in October 1936, he started to attend the fighter pilot training. He managed his first shot down as a commander of 6. Staffel JG 51 when he downed a Spitfire above Dunkerque on May 28th, 1940. In November 1940, he was appointed a commander of the 1./ JG 26. On December 6th, 1941, he became commander of III./ JG 26, from January 11th, 1943 he lead the whole Jagdgeschwader 26. His total number of shot downs kept growing. On December 20th, 1941, his successes were rewarded - Priller was decorated with Knights Cross of the Iron Cross with Oak Leaves and Swords. On January 28th, 1945, he was appointed a post of an Inspekteur der Jagdflieger Ost, where he remained till the end of WWII. Priller's total score of shot downs was 101 enemy aircraft. All of the shot downs happened in the Western Front. After war he married Johanna Riegele, the proprietor of a brewery and became general manager of Riegele brewery in Augsburg, Germany. He died of heart attack on May 20th, 1961. The aircraft has a standard camouflage of Luftwaffe interceptors with yellow rudder and bottom part of the engine cover. This is the plane Josef Priller flew in May 1943. It first bore Geschwader commander marking (without Adlerflügel behind exhausts), which later got repainted to black 13 and Adlerflügel was added. Priller's machine was equipped with Erla rack under fuselage.

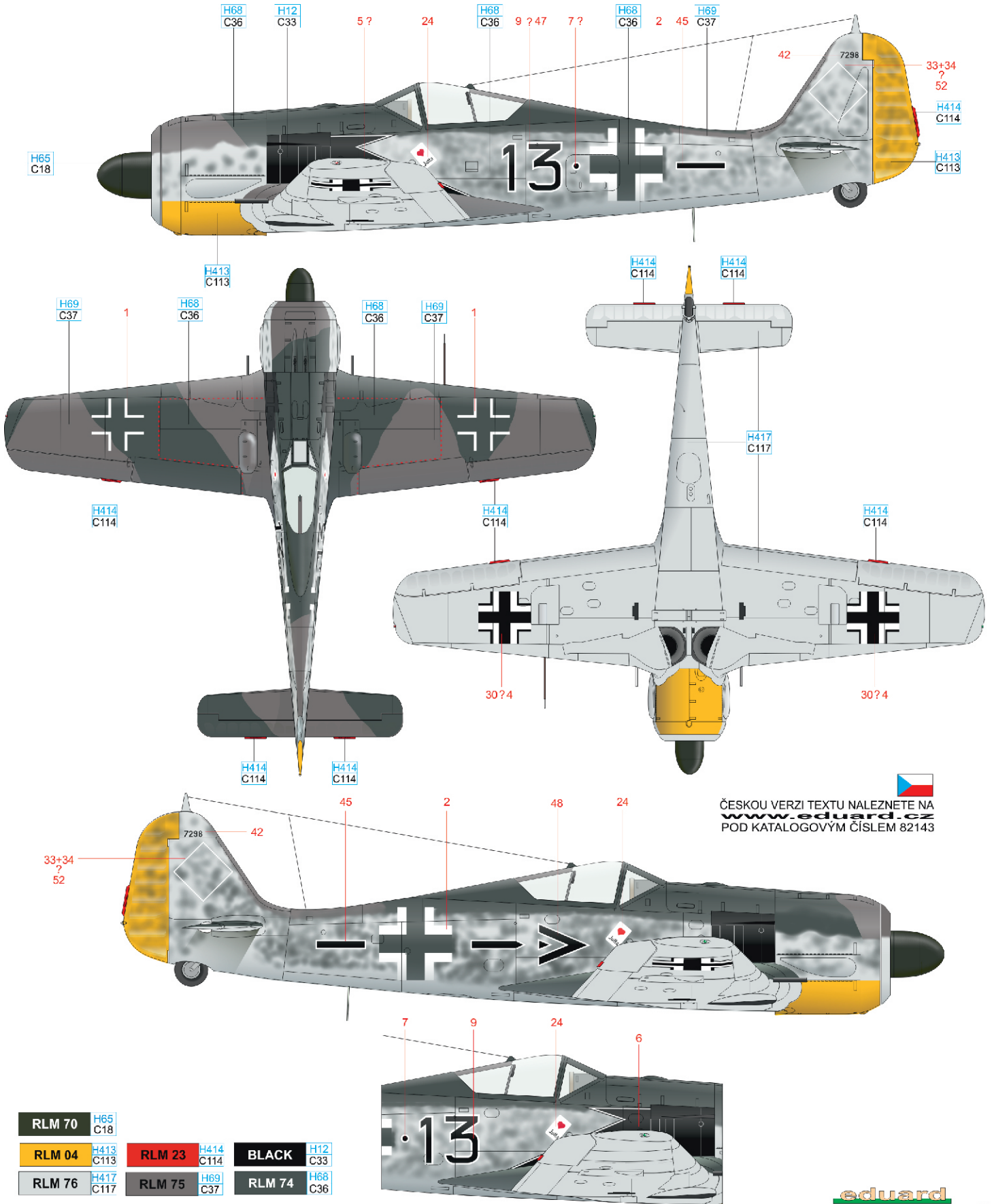

B W. Nr. 1501, Oblt. Walter Nowotny, CO of 1./JG 54, Orel, Soviet Union, Summer 1943

A German fighter pilot of Austrian decent and a native of Gmünd situated near the border with Czechoslovakia, Walter 'Nowi' Nowotny was a holder of the Knight's Cross with Oak Leaves, Swords and Diamonds, and shot down 258 enemy aircraft over the course of 442 combat sorties. He was killed in an Me 262 Schwalbe in combat with American escort fighters near an airfield at Hesepe on November 8th, 1944. "Nowi's" aircraft got a non-standard camouflage consisting of two shades of dark green, most likely RLM 70 and its combination with another colour. The yellow wingtips of the undersides and yellow band round the fuselage identified the aircraft flying in the Eastern Front. The JG 54 aircraft bore yellow band on the fuselage, underneath the fuselage crosses, and bottom part of the rudder was painted yellow as well. The front part of the propeller spinner bore, most likely, yellow spiral. Underneath the cockpit there was a personal symbol of the pilot.

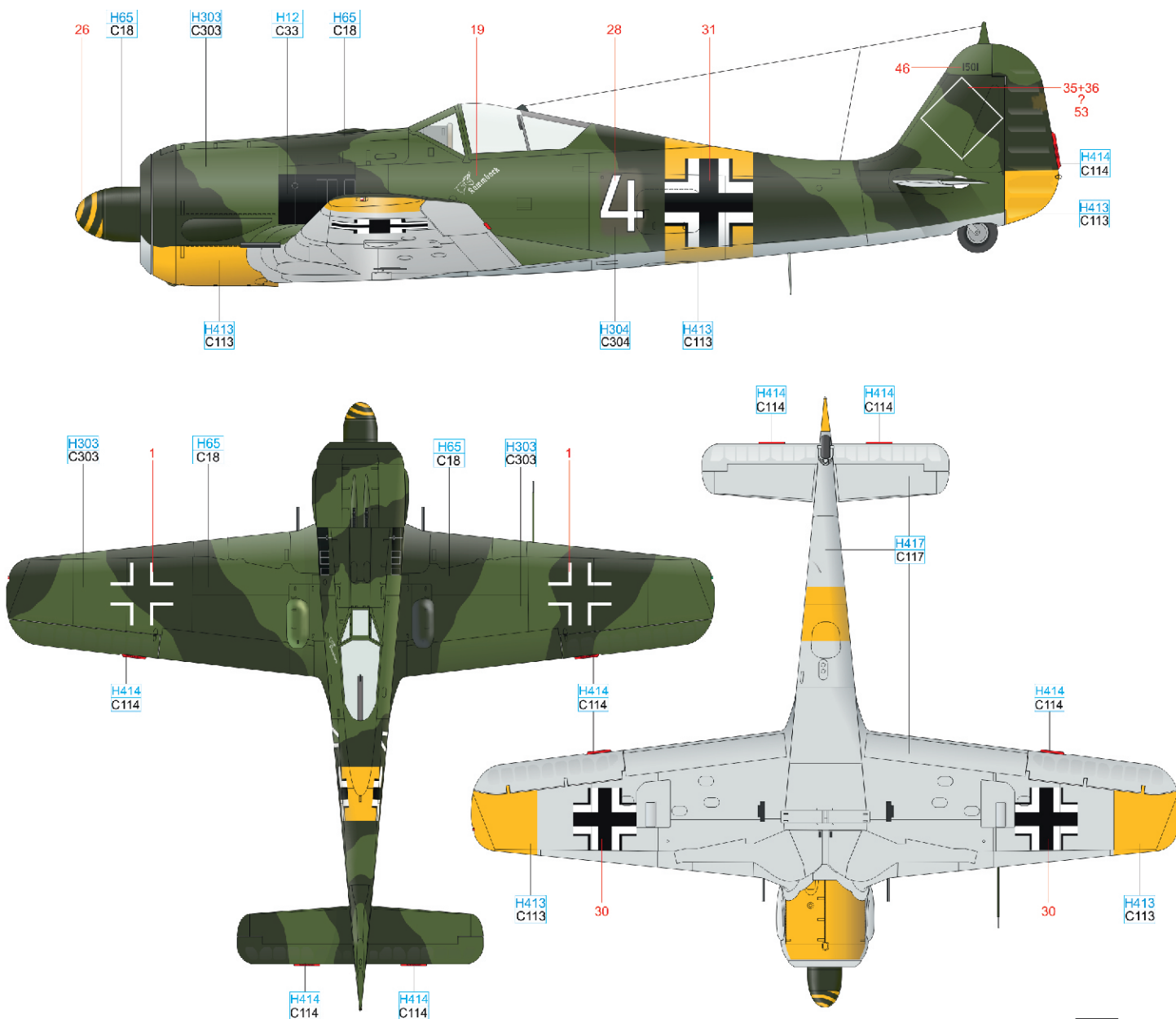

ČESKOU VERZI TEXTU NALEZNETE NA
www.eduard.cz
 POD KATALOGOVÝM ČÍSLEM 82143

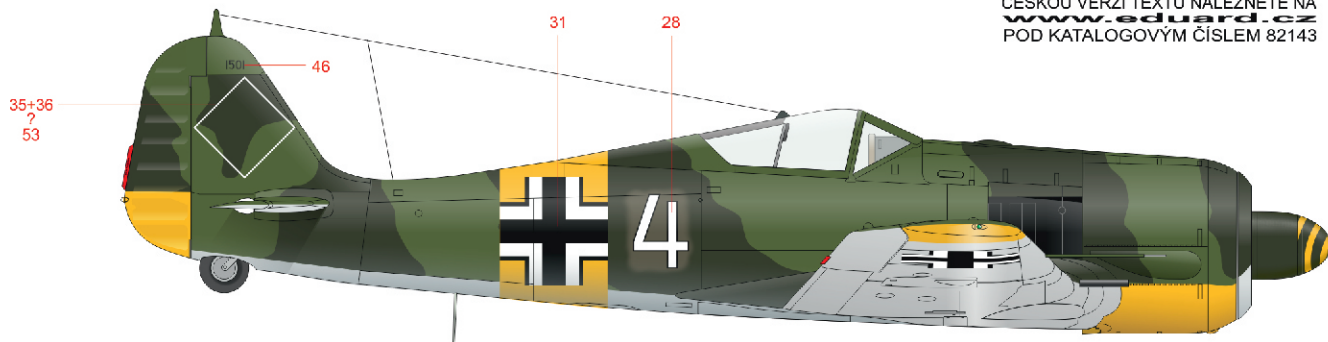

RLM 23	H414 C114	RLM 04	H413 C113	BLACK	H12 C33
GREEN	H303 C303	RLM 70	H65 C18	RLM 76	H417 C117
				GREEN	H304 C304

C flown by Oblt. Rolf Strohal, Stab I./JG 1, Deelen, the Netherlands, April 1943

Rolf Strohal came from Romania. In 1942 he served at 12. Staffel Jagdgeschwader 1. In April 1943, he was appointed to Technisches Offizier position by I. Gruppe JG 1. In August 1943, he was appointed a commander of 3. Staffel by the same squadron. In the autumn of that year, he was transferred to a training squadron Jagdgruppe West. On December 31st, 1943, he died serving at this squadron. It happened above the Southwest France while flying Fw 190A-4, Strohal collided with another aircraft of the same kind. He had 4 recognized shot downs – one Mosquito and three B-17s. In April 1943, Stab I./JG 1 aircraft had their Fw 190 engine covers painted with black and white horizontal bands. The engine cover also bears insignia of I./JG 1, there is a JG1 insignia painted underneath the cockpit. The camouflage is accompanied by RLM 74/75/76 colours that be complementing the yellow rudder and bottom part of the engine cover. The sides of the fuselage bear the marking of the plane used by technical officer.

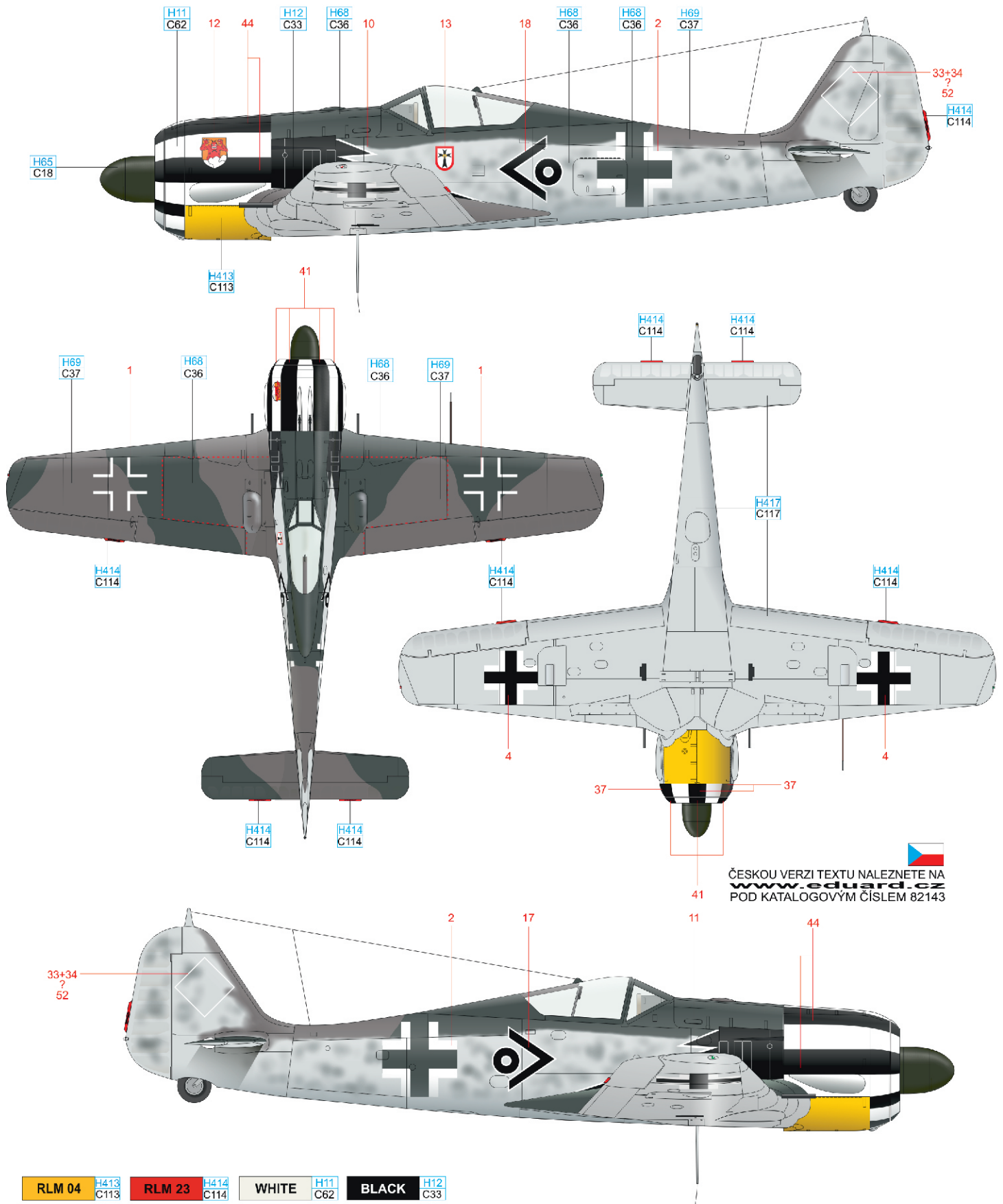

ČESKOU VERZI TEXTU NALEZNETE NA
www.eduard.cz
 POD KATALOGOVÝM ČÍSLEM 82143

RLM 04	H413 C113	RLM 23	H414 C114	WHITE	H11 C62	BLACK	H12 C33
RLM 76	H417 C117	RLM 75	H69 C37	RLM 74	H68 C36	RLM 70	H65 C18

II. Gruppe Schlachtgeschwader 1, established on January 13th, 1942, was first equipped with Henschels Hs 123 and Hs 129. In 1942, the Gruppe operated in Eastern Front, its 5. and 6. Staffel were sent to Northern Africa in November of the same year. At the beginning of 1943, the 5., 6. and 7. Staffel got new and powerful Fw 190A-5s, which they used in Kuban to support the intensive fights of the ground troops. In June 1943, there was rearmament for more suitable planes - Fw 190F-3. Standard camouflage of Fw 190A-5 accompanied the marking of the aircraft flying in the Eastern Front. There were yellow complements at the bottom part of the wingtips and yellow band on the fuselage. Luftwaffe interceptors were marked with letters, the aircraft 6./Schl. G1 bore black triangle lined with white, and it was positioned behind the fuselage cross. The engine cover was decorated with the Mickey Mouse - the squadron marking.

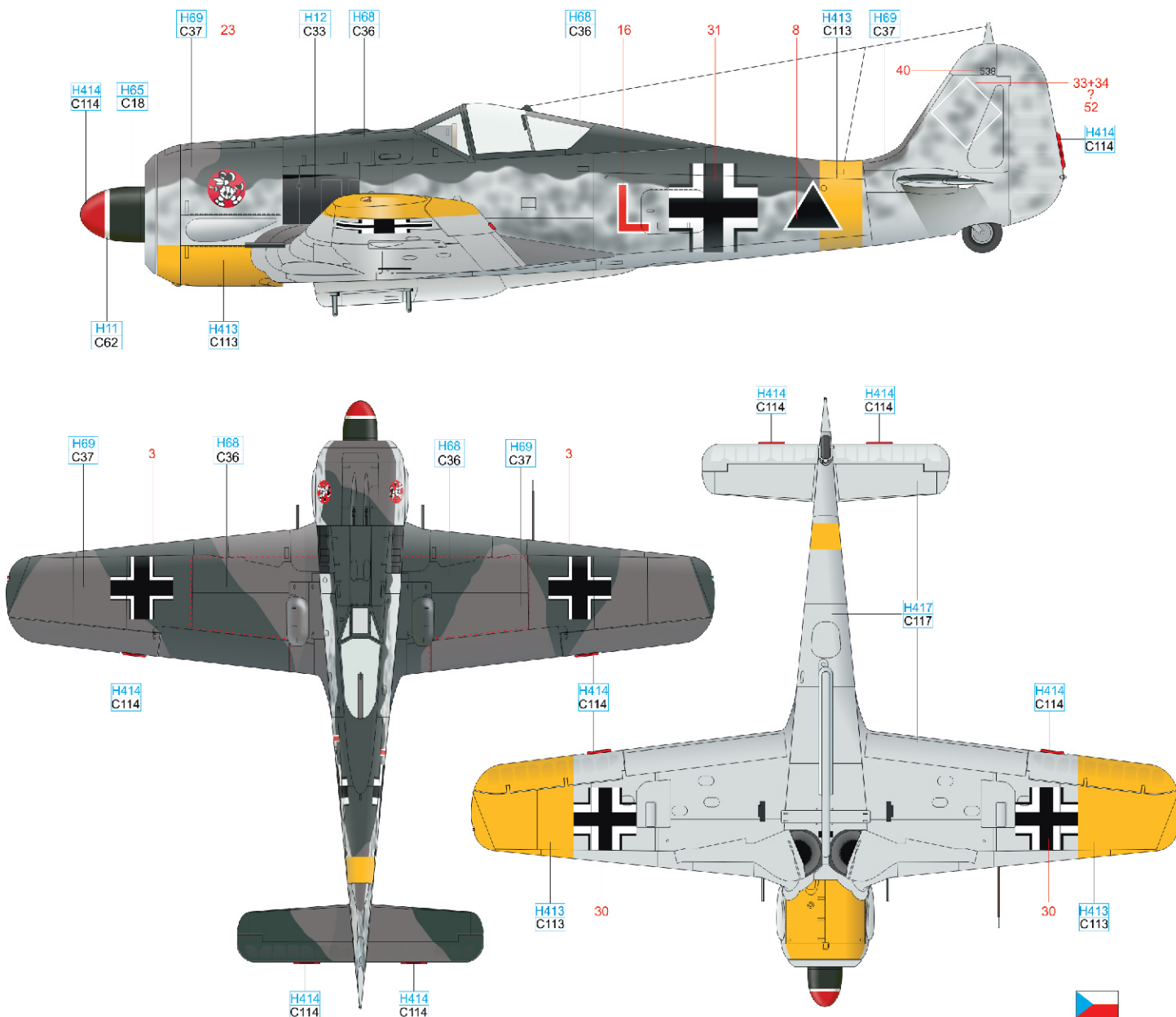

ČESKOU VERZI TEXTU NALEZNETE NA
www.eduard.cz
 POD KATALOGOVÝM ČÍSLEM 82143

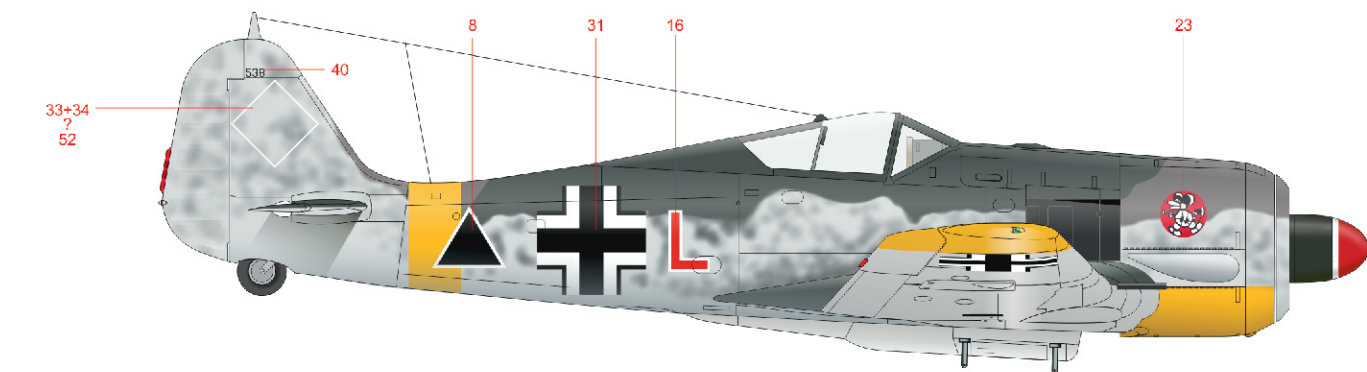

RLM 04	H413 C113	RLM 23	H414 C114	WHITE	H11 C62	BLACK	H12 C33
RLM 76	H417 C117	RLM 75	H69 C37	RLM 74	H68 C36	RLM 70	H65 C18

