

Fw 190A-2

eduard

GERMAN WWII FIGHTER

1/48 SCALE PLASTIC KIT

ProfiPACK
edition

#82146



INTRO

The second half of the Second World War saw the Focke-Wulf Fw 190, in its various forms, emerge as the best of what was available to the Luftwaffe. The dedicated fighter version was a high performance, heavily armed machine. Its development had a precarious beginning, against a 1938 specification issued by the Technisches Amt, RLM. The first prototype took to the air on June 1st, 1939. After a series of improvements and even radical changes, the design culminated in the fall of 1940 in the pre-series version Fw 190A-0 to the tune of twenty-eight pieces. Six of these were retained by the test unit Erprobungsstaffel 190 at Rechlin, which was tasked with conducting service trials. These revealed a wide range of flaws to the point where the RLM halted further development. Despite this, on the basis of urgings from the test unit staff, the aircraft was not shelved. After a series of some fifty modifications, the RLM gave the go ahead for the Fw 190 to be taken into inventory of the Luftwaffe. In June 1941 the Luftwaffe accepted the first of 100 ordered Fw 190A-1s, armed with four 7.9 mm MG 17s. By September 1941 II./JG 26 was completely equipped with the type operating on the Western Front. November saw the production of the next version Fw 190A-2, powered by a BMW 801C-2, and armed with two 7.9 mm MG 17s and two MG 151s of 20 mm caliber in the wings. Part of this series received an additional pair of 20 mm MG FFs, thus attaining an armament standard of later types. A significant advancement to the design came in the spring 1942, when the BMW 801D-2 became available, whose installation gave birth to the Fw 190A-3. July saw the development of the improved A-4. Both were armed with what became the standard two fuselage mounted MG 17s, two wing mounted MG 151 cannons, and two MG FF cannons, placed inboard of the wheel wells. During 1942 production had intensified, and a production facility was set up under license at Fieseler. Thanks in part to this, production rose in 1942 to 1,878 units as opposed to 224 in 1941. Large-scale production of the A-5 was initiated in April 1943 with an identical wing to the A-4, but with a nose extension that would become standard on all subsequent Fw 190A versions up to the A-9, and also on the corresponding F types. July saw the development of a new, strengthened wing, which incorporated MG 151s instead of the MG FFs in the outer position. The adoption of this wing developed the A-6 version. Further changes developed the A-7, produced during the end of 1943. This version came about with the replacement of the fuselage mounted MG 17s with 13 mm MG 131s. Further improvements led to the Fw 190A-8, and this version became the most widely produced with some 6,655 units made. The most significant change to this variant was the installation of the GM-1 nitrous-oxide injection system, for temporary power boost in combat. A portion of A-8 production was built as the A-8/R2 and A-8/R8, armed with MK 108 cannon in the outer wing location, and with armoured slabs added to the cockpit sides and a modified canopy. The final production version of the BMW 801 powered fighter was the Fw 190A-9, equipped with the BMW 801TS of 2000 hp (1470 kW). There was a parallel development of these fighter optimized aircraft with a dedicated fighter-bomber version, the Fw 190F. These aircraft had reduced wing armament to two MG 151 cannons in the wing root position. The engine was optimized for low level operation, and the armament options varied to satisfy the ground attack role, including bombs of various weight classes and a variety of anti-tank rockets. This branched into the extended range Fw 190G version. Development of the throughbred fighter continued in the guise of the Fw 190D, which began to reach Luftwaffe units in the second half of 1944, and was the result of mounting an in-line Jumo 213A-1 engine into a modified Fw 190A-8 airframe. Although the Fw 190 never achieved the widespread usage of the competing Bf 109, its contribution to the German Air Force was certainly significant through the second half of WWII. Fw 190s saw service on the Western Front as well as in the East. As heavy fighters with imposing firepower, they found themselves integral components, from 1943 onwards, within the units tasked with the protection of the Reich from the ominous clouds of allied four-engined bombers. This is where the A-8 version was instrumental, along with its A-8/R2 armoured development. This version, with its firepower, was a very ominous and daunting foe for the bomber crews. From the second half of 1944, their danger was kept in check to a degree by escorting P-47s, and necessitated the development of the P-51 Mustang.

ATTENTION



UPOZORNĚNÍ



ACHTUNG



ATTENTION



注意



Carefully read instruction sheet before assembling. When you use glue or paint, do not use near open flame and use in well ventilated room. Keep out of reach of small children. Children must not be allowed to suck any part, or pull vinyl bag over the head.



Před započítím stavby si pečlivě prostudujte stavební návod. Při používání barev a lepidel pracujte v dobře větrané místnosti. Lepidla ani barvy nepoužívejte v blízkosti otevřeného ohně. Model není určen malým dětem, mohlo by dojít k požití drobných dílů.

INSTRUCTION SIGNS * INSTR. SYMBOL * INSTRUKTION SINNBILDEN * SYMBOLES * 記号の説明

OPTIONAL
VOLBABEND
OHNOUOPEN HOLE
VYVRTAT OTVORSYMETRICAL ASSEMBLY
SYMETRICKÁ MONTÁŽREMOVE
ODŘÍZNOUTREVERSE SIDE
OTOČITAPPLY EDUARD MASK
AND PAINT
POUŽIT EDUARD MASK
NABARVIT

PARTS



DÍLY



TEILE



PIÈCES



部品

A>

82140 A

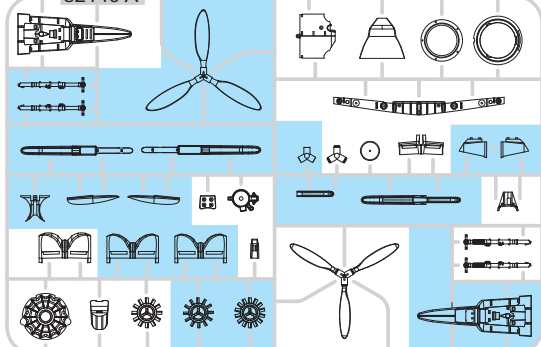

B>

PLASTIC PARTS

82140 B

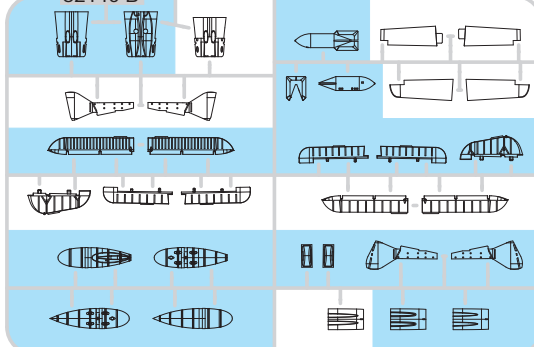

N>

82140 N

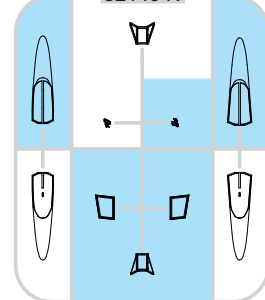

C>

82140 C

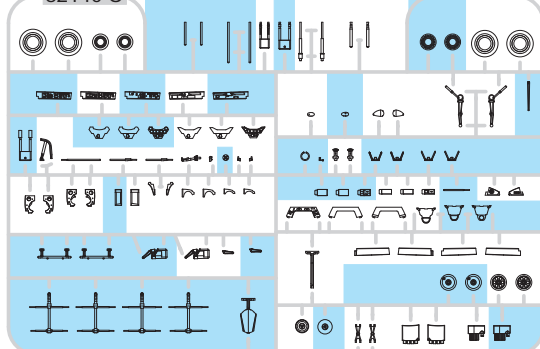

D>

82140 D

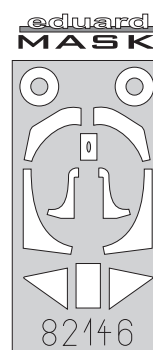
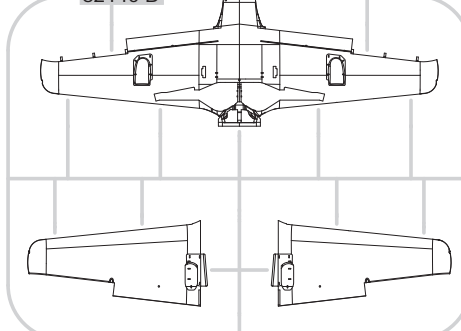

E>

82140 E

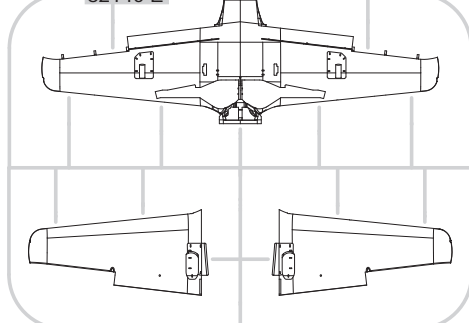

O>

82140 O

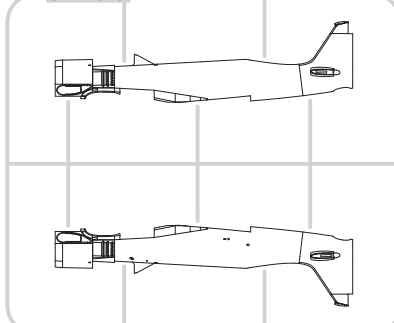

RP - RESIN PARTS

eduard
BRASSIN

R81

R82

PE - PHOTO ETCHED DETAIL PARTS

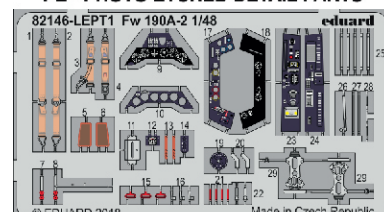

-Parts not for use. -Teile werden nicht verwendet. -Pièces à ne pas utiliser. -Tyto díly nepoužívejte při stavbě. - 使用しない部品

COLOURS



BARVY



FARBEN



PEINTURE



色

GSI Creos (GUNZE)		MISSION MODELS	
AQUEOUS	Mr.COLOR	PAINTS	
H1	C1	MMP-001	WHITE
H2	C2	MMP-047	BLACK
H11	C62	MMP-001	FLAT WHITE
H12	C33	MMP-047	FLAT BLACK
H33	C81		RUSSET
H47	C41	MMP-012	RED BROWN
H65	C18	MMP-088	RLM70 BLACK GREEN
H68	C36	MMP-049	RLM74 DARK GRAY
H69	C37	MMP-050	RLM75 GRAY
H70	C60	MMP-056	RLM02 GRAY
H77	C137	MMP-040	TIRE BLACK

GSI Creos (GUNZE)		MISSION MODELS	
AQUEOUS	Mr.COLOR	PAINTS	
H90	C47		CLEAR RED
H94	C138		CLEAR GREEN
H413	C113	MMP-090	RLM04 YELLOW
H414	C114	MMP-003	RLM23 RED
H416	C116	MMP-089	RLM66 BLACK GRAY
H417	C117	MMP-051	RLM76 LIGHT BLUE
Mr.METAL COLOR		METALLICS	
MC213		MMM-006	STEEL
MC214		MMM-001	DARK IRON
Mr.COLOR SUPER METALLIC		METALLICS	
SM06		MMC-001	CHROME SILVER

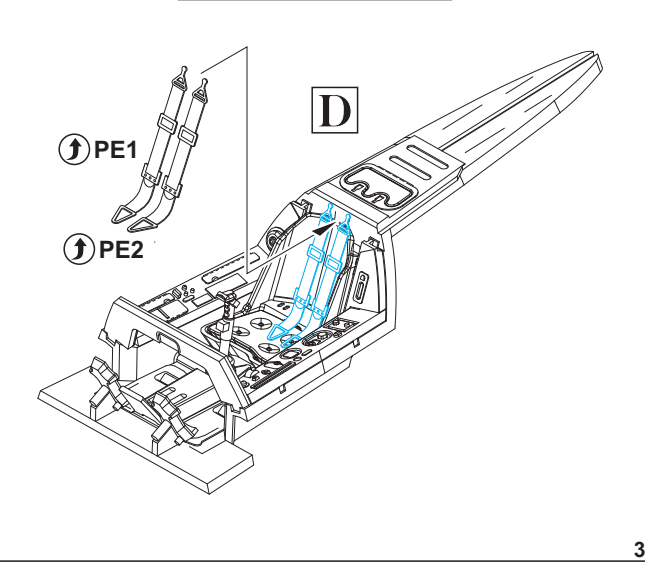
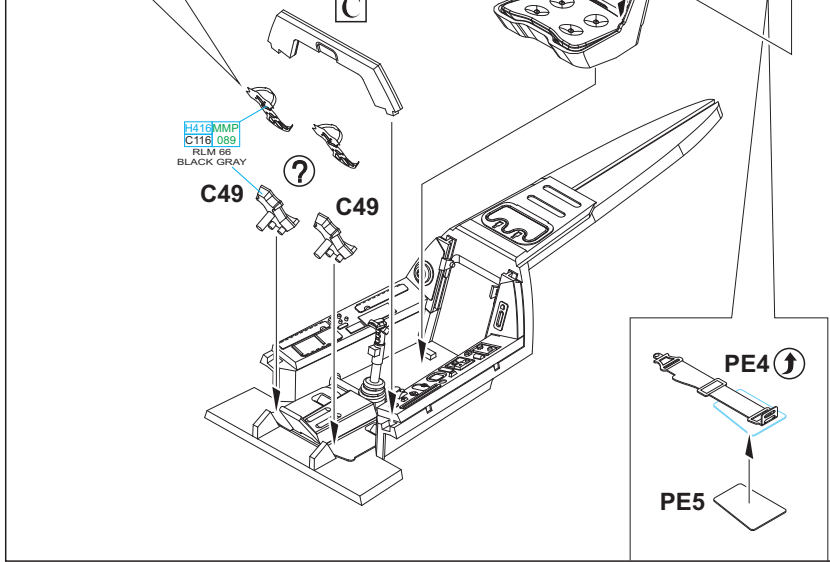
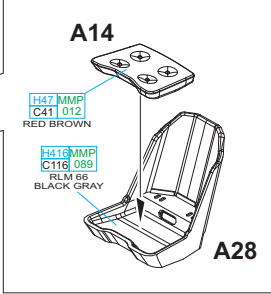
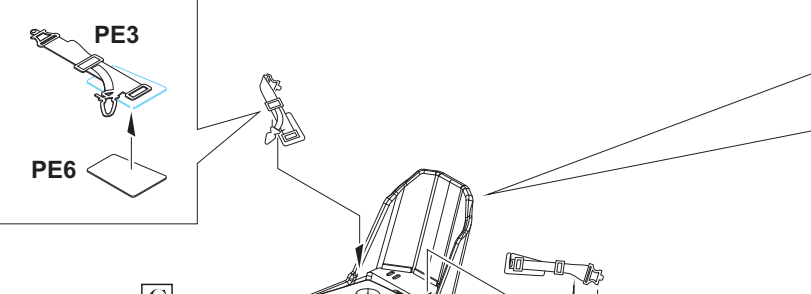
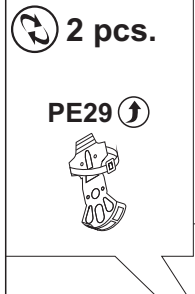
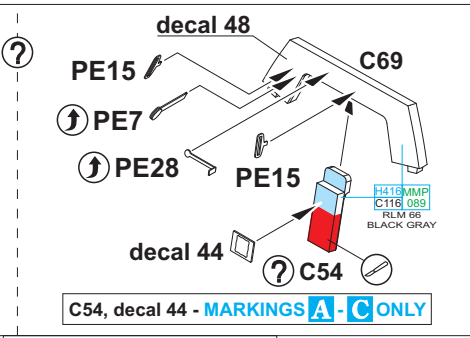
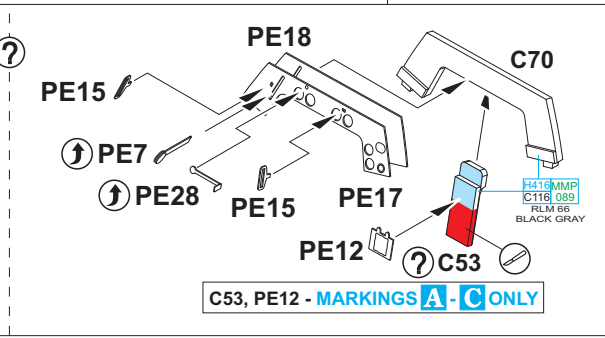
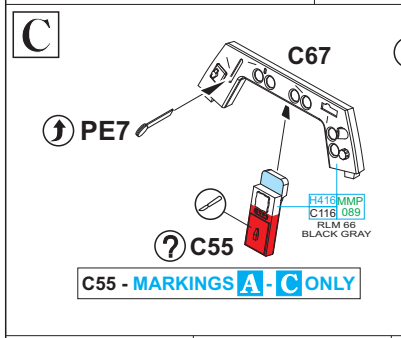
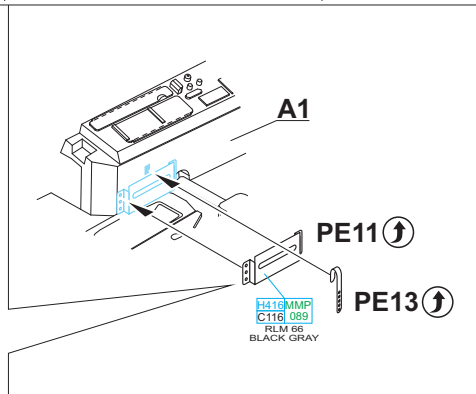
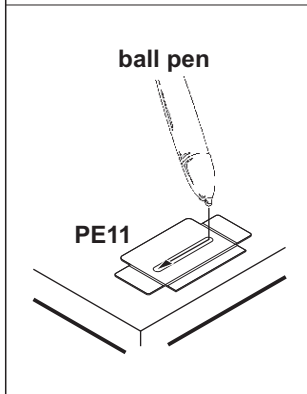
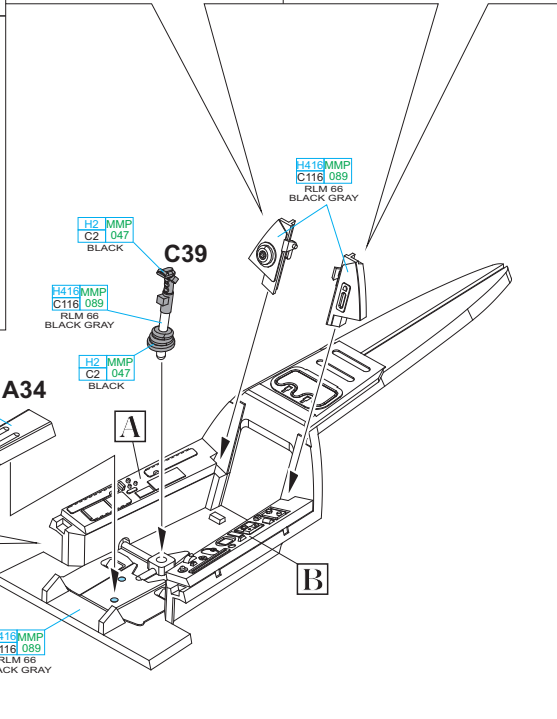
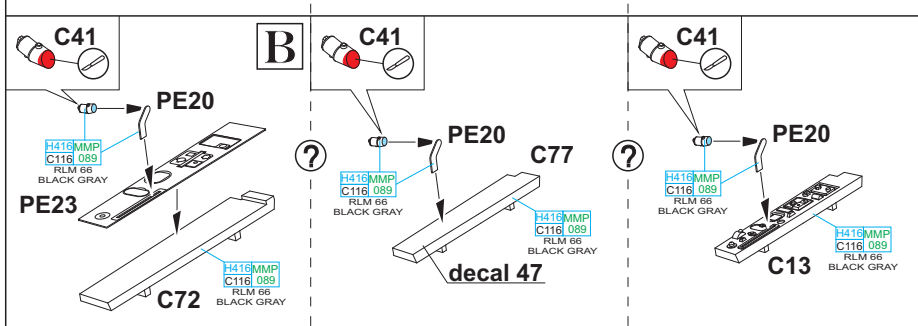
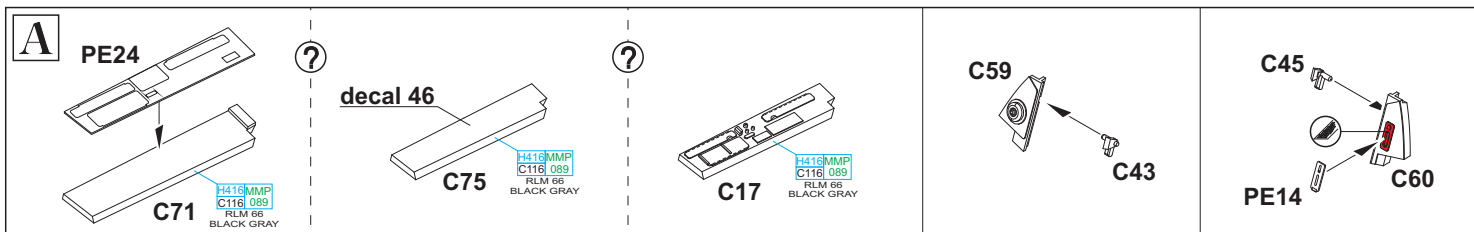

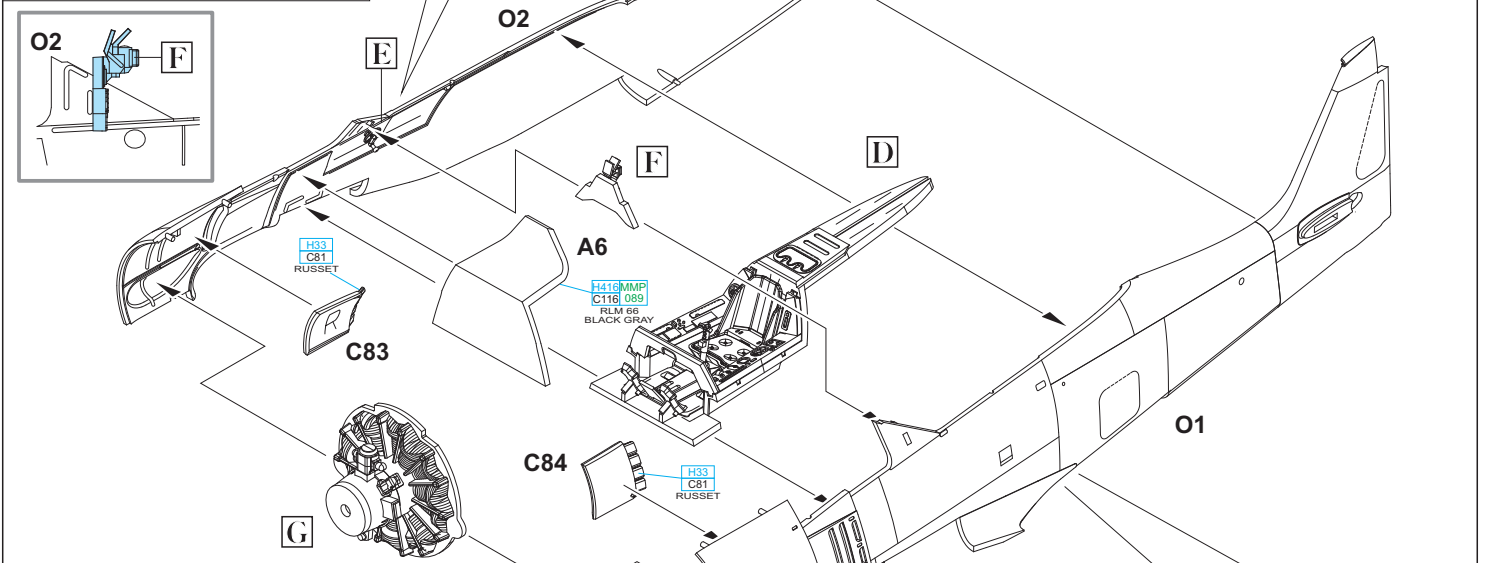
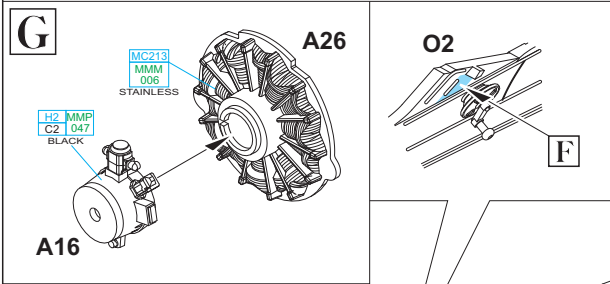
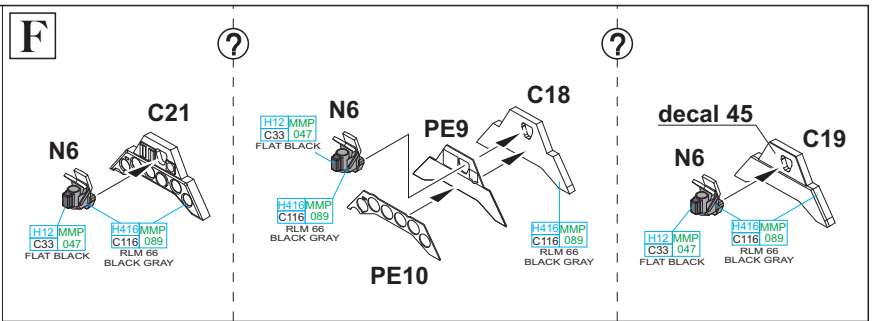
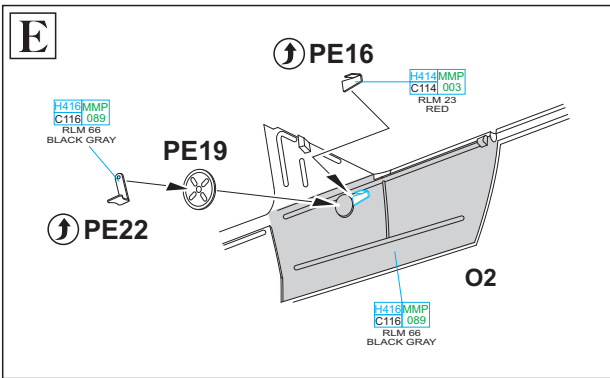

D2 - MARKINGS **A, B, C**
E2 - MARKINGS **D, E**

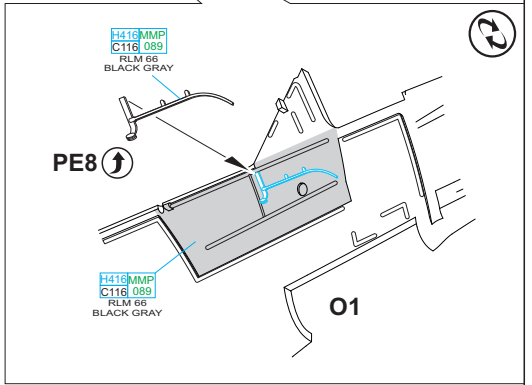
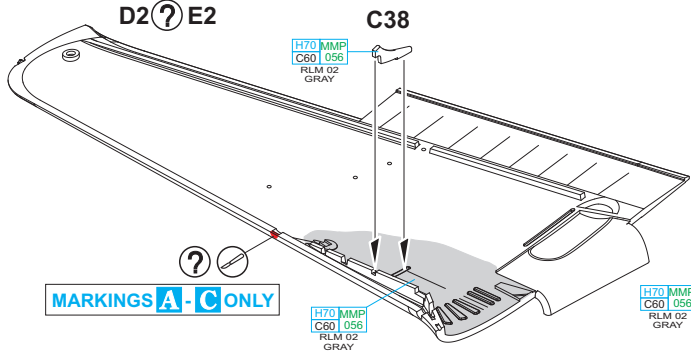

MARKINGS **A - C ONLY**

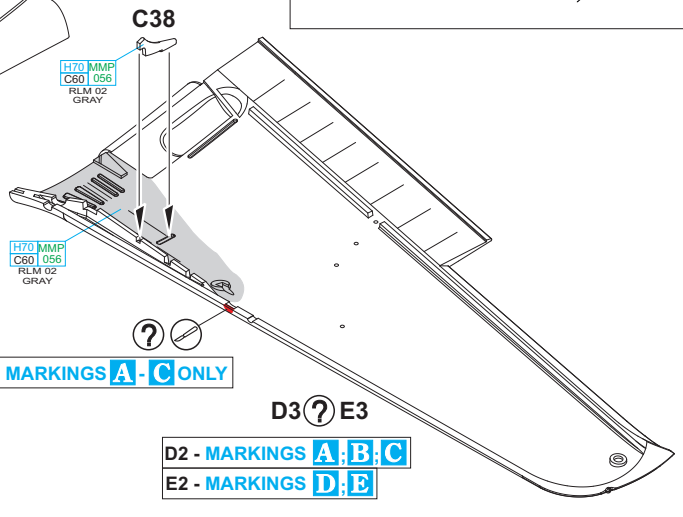

D2 - MARKINGS **A, B, C**
E2 - MARKINGS **D, E**

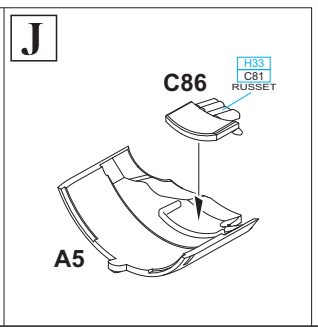
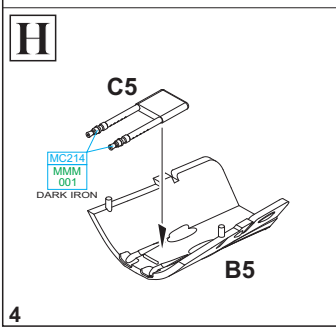

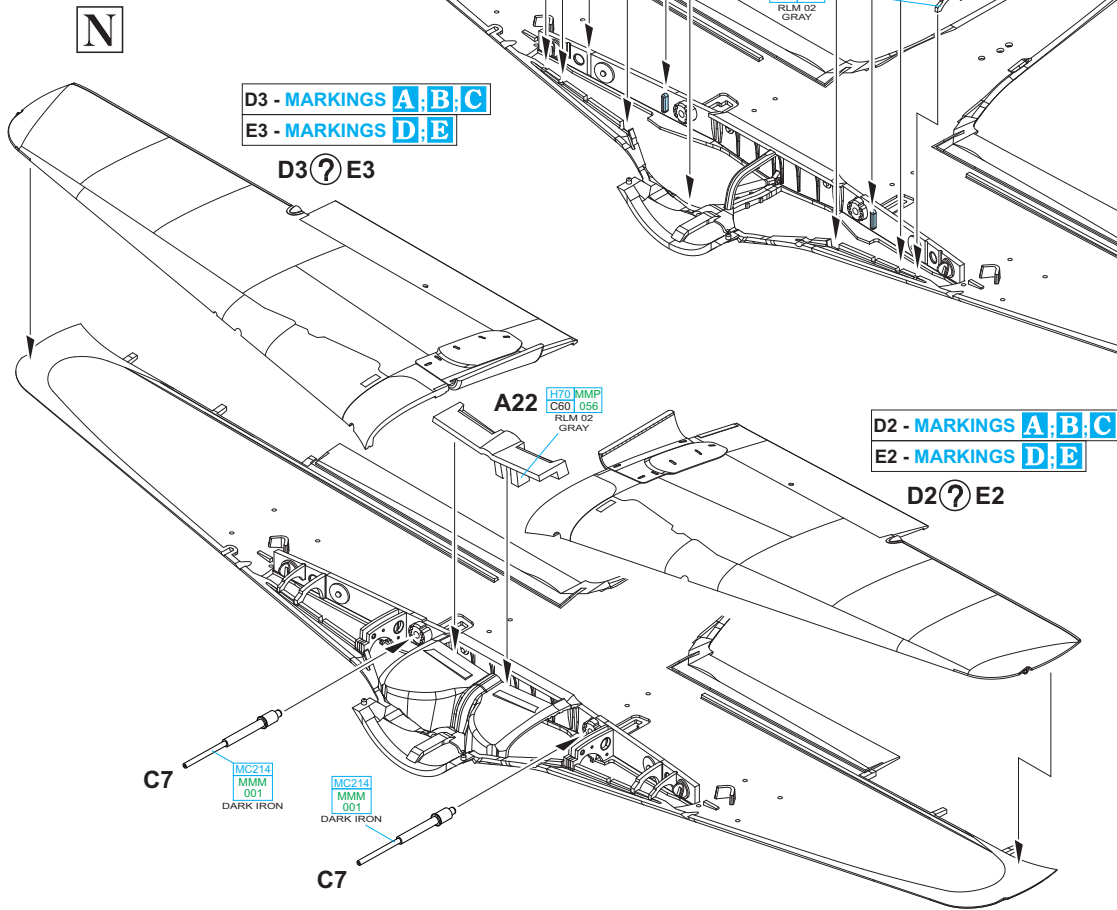
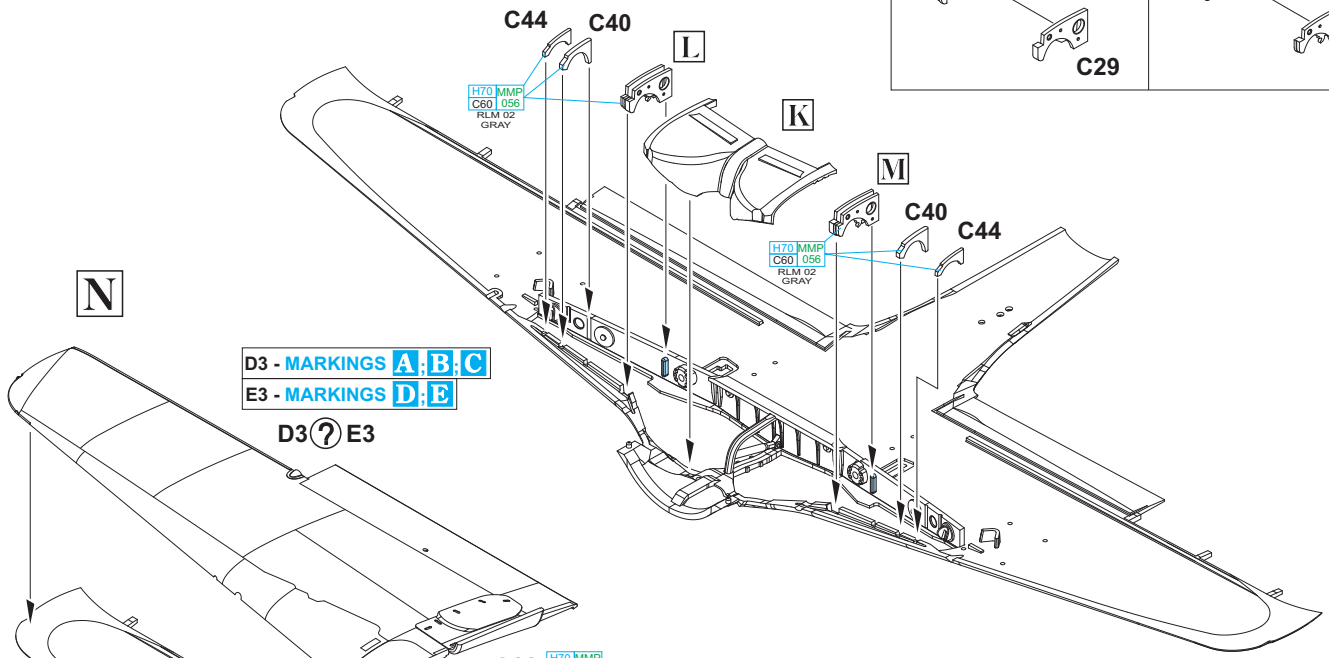
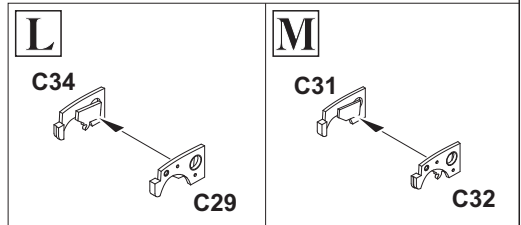
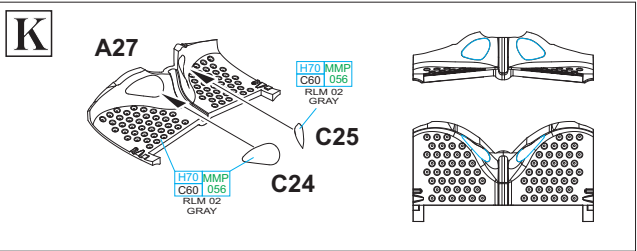
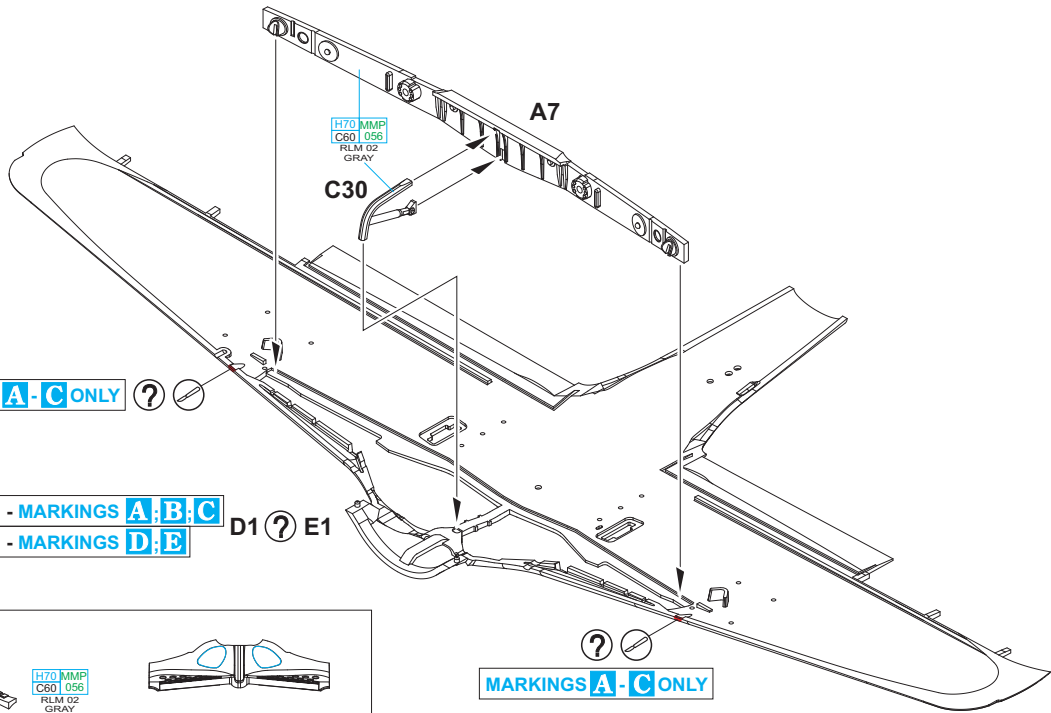

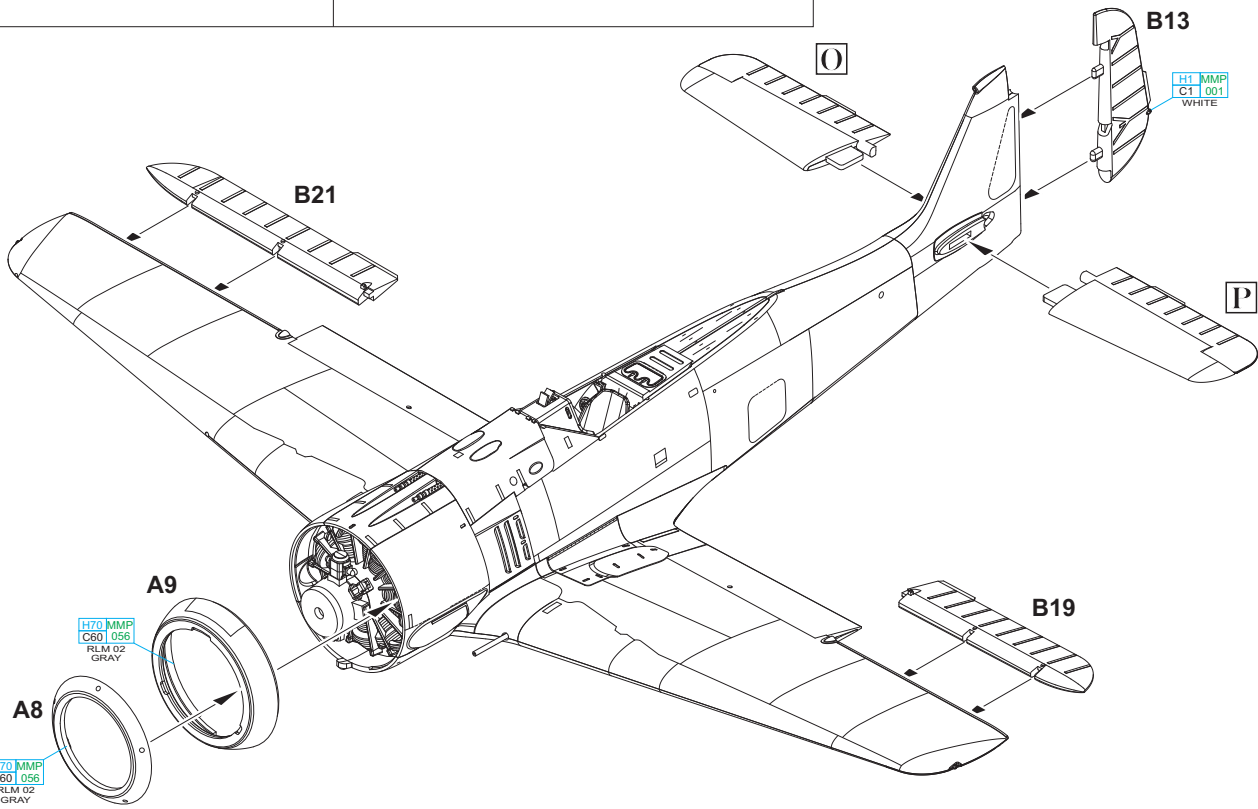
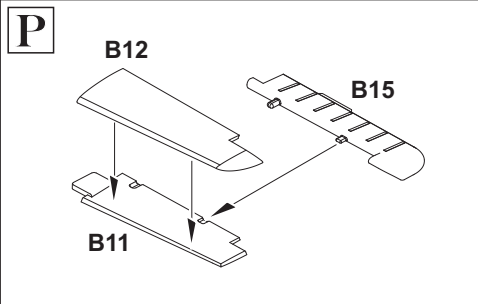
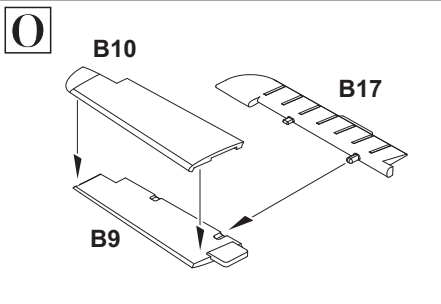
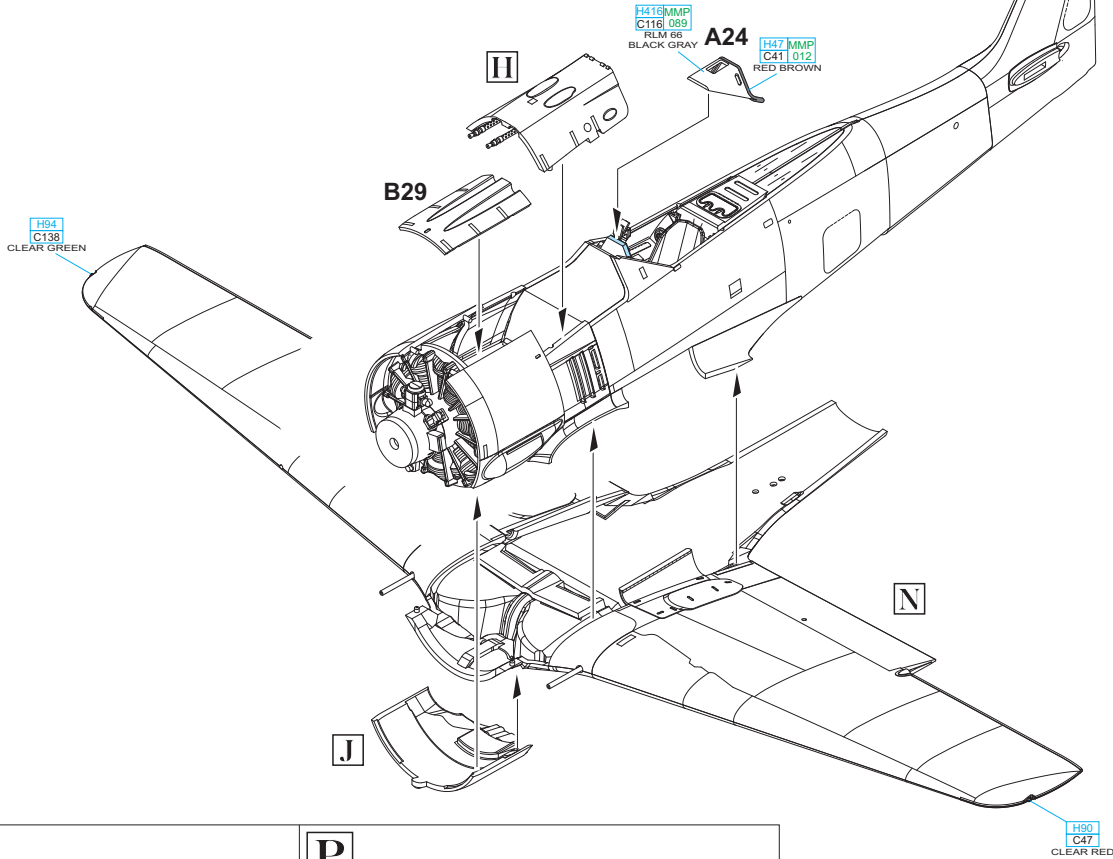
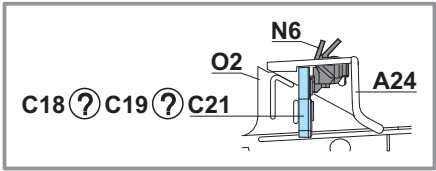

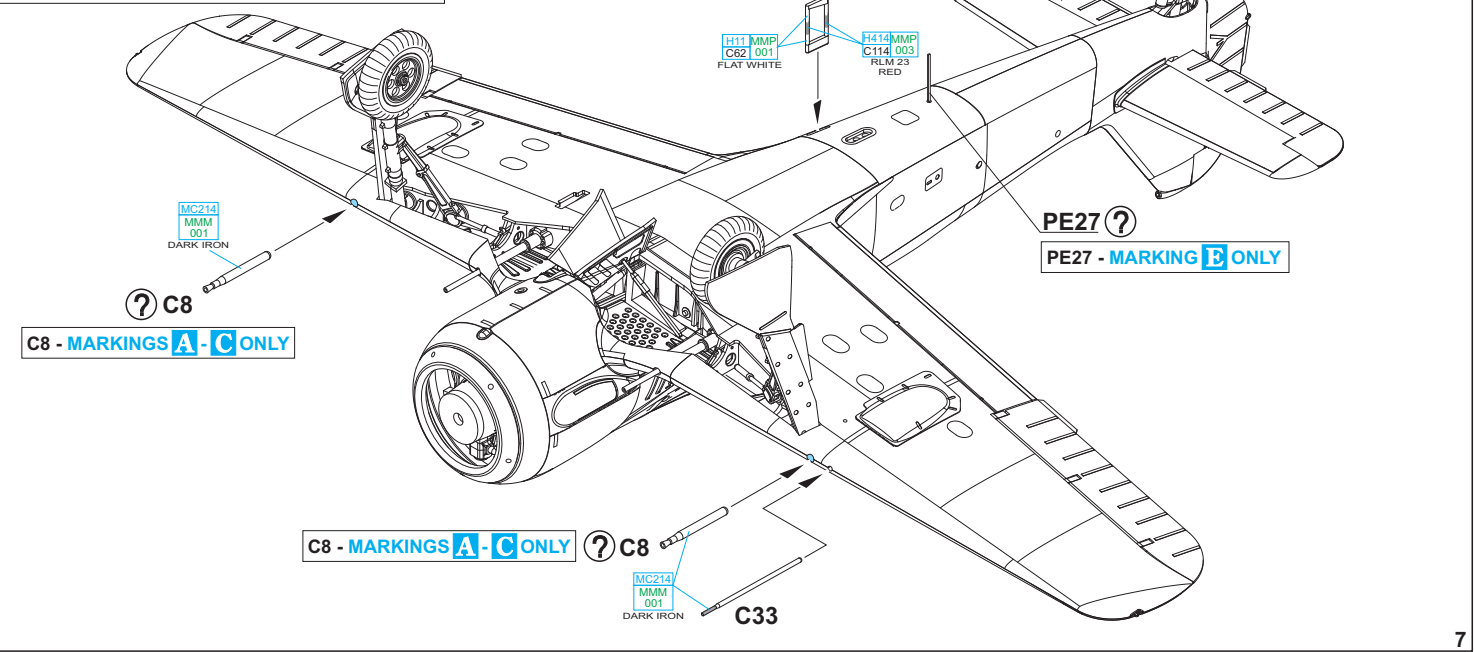
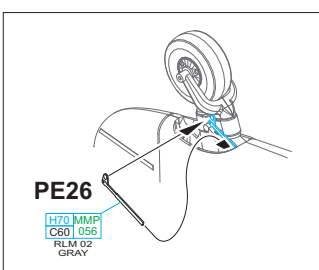
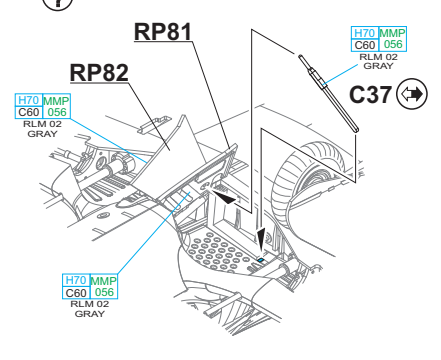
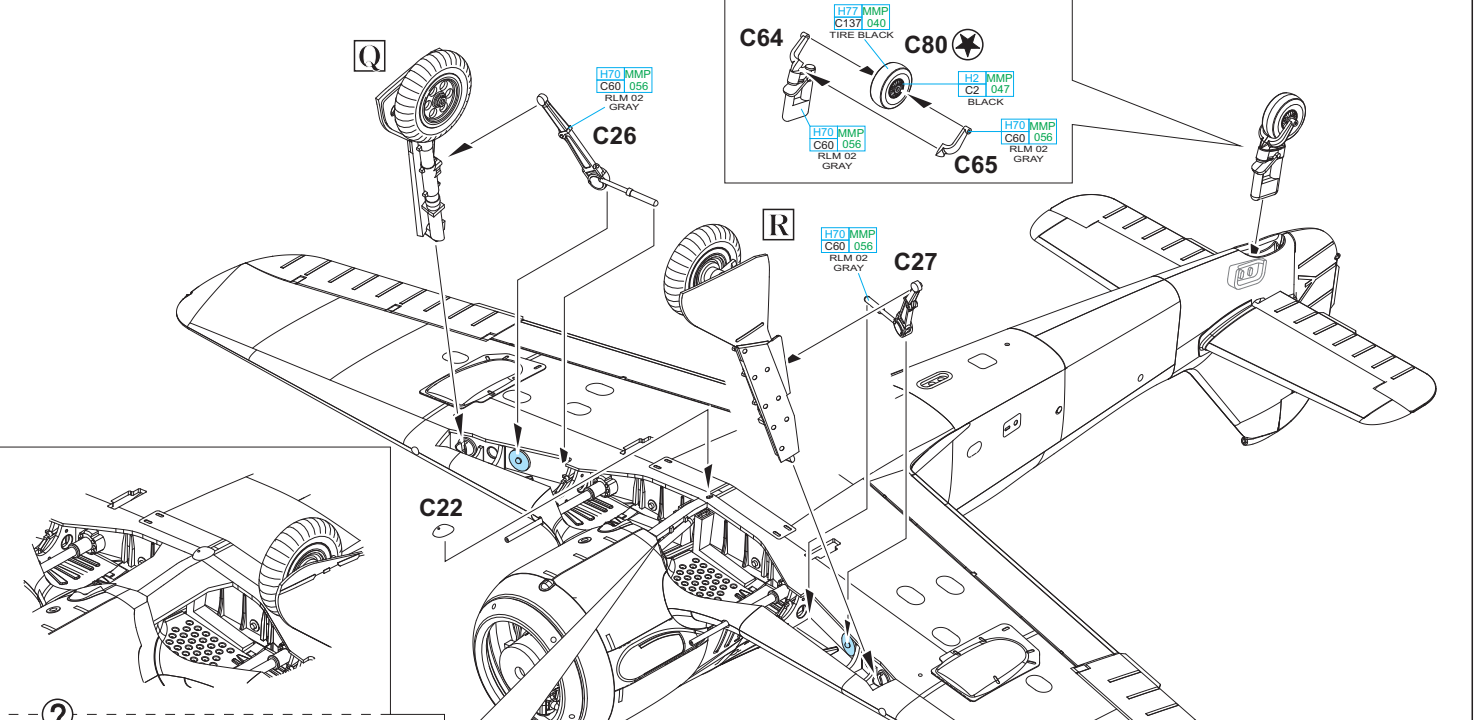
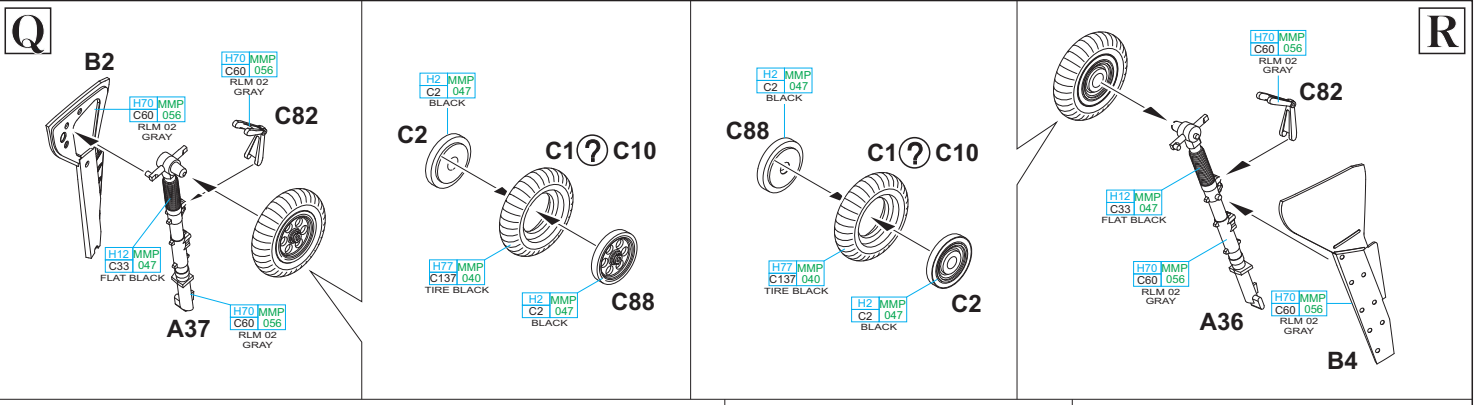

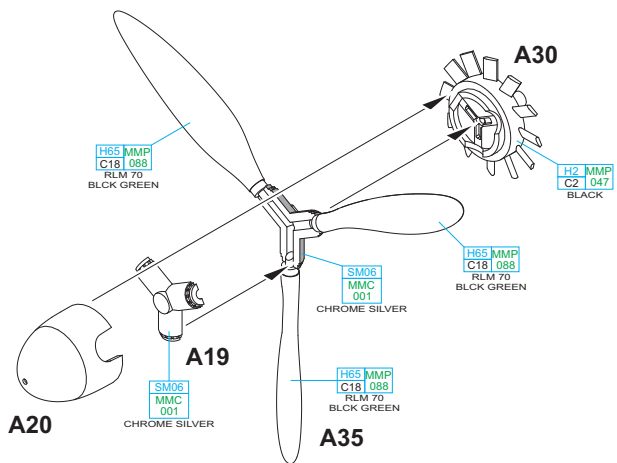
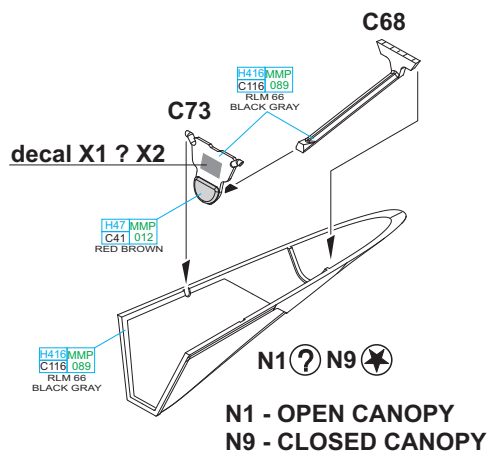
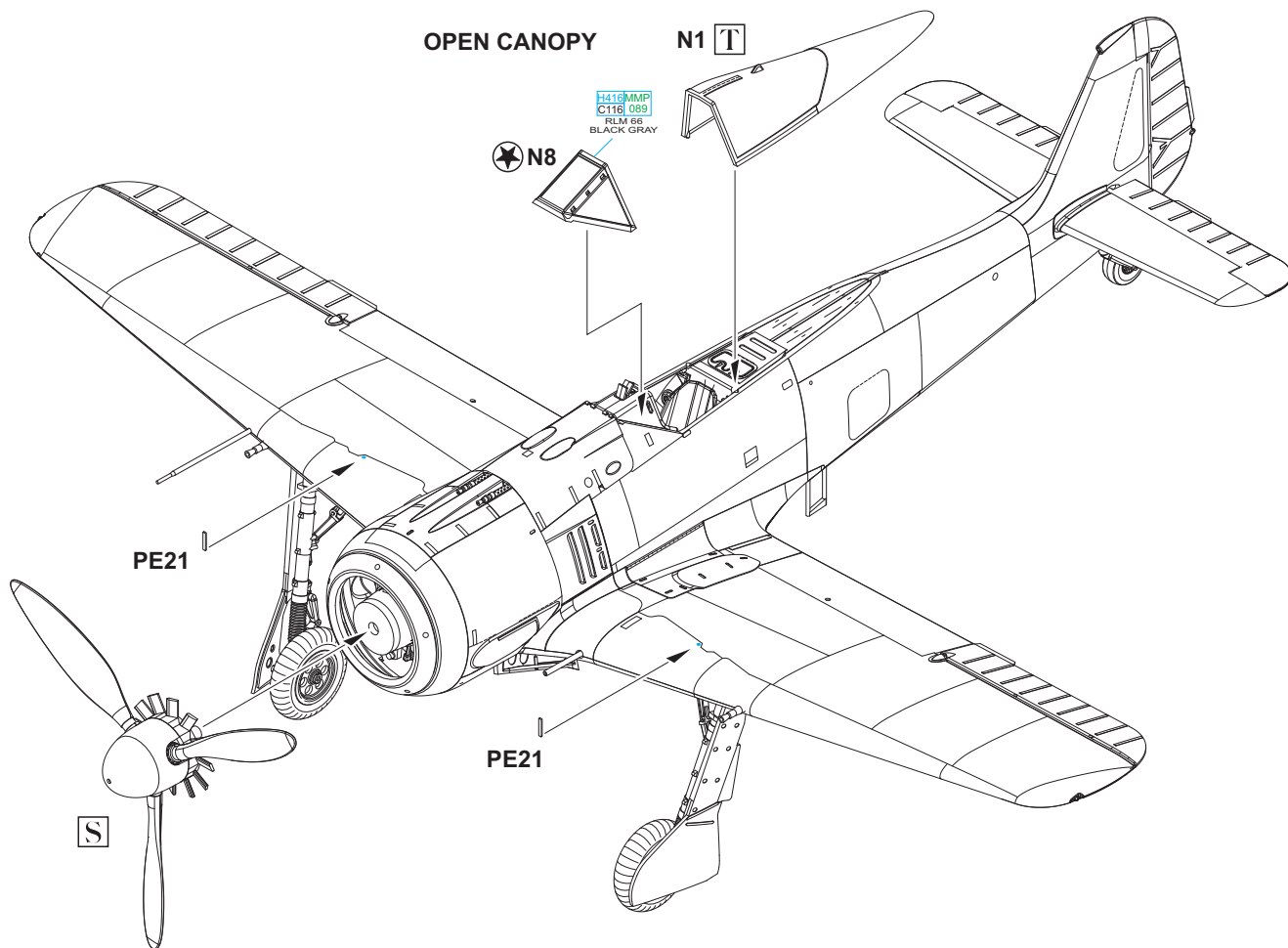
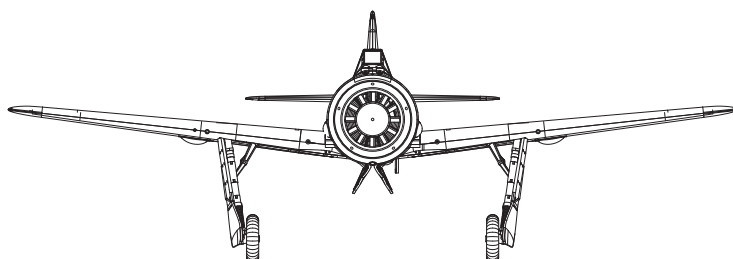
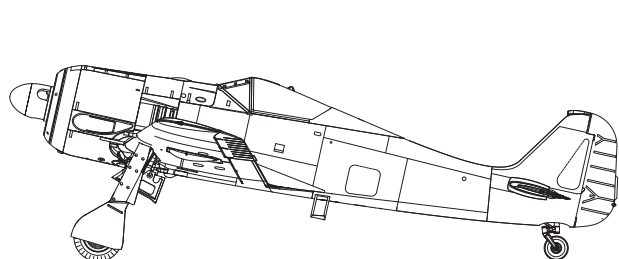
S**T****OPEN CANOPY****N1 T****S**

CLOSED CANOPY

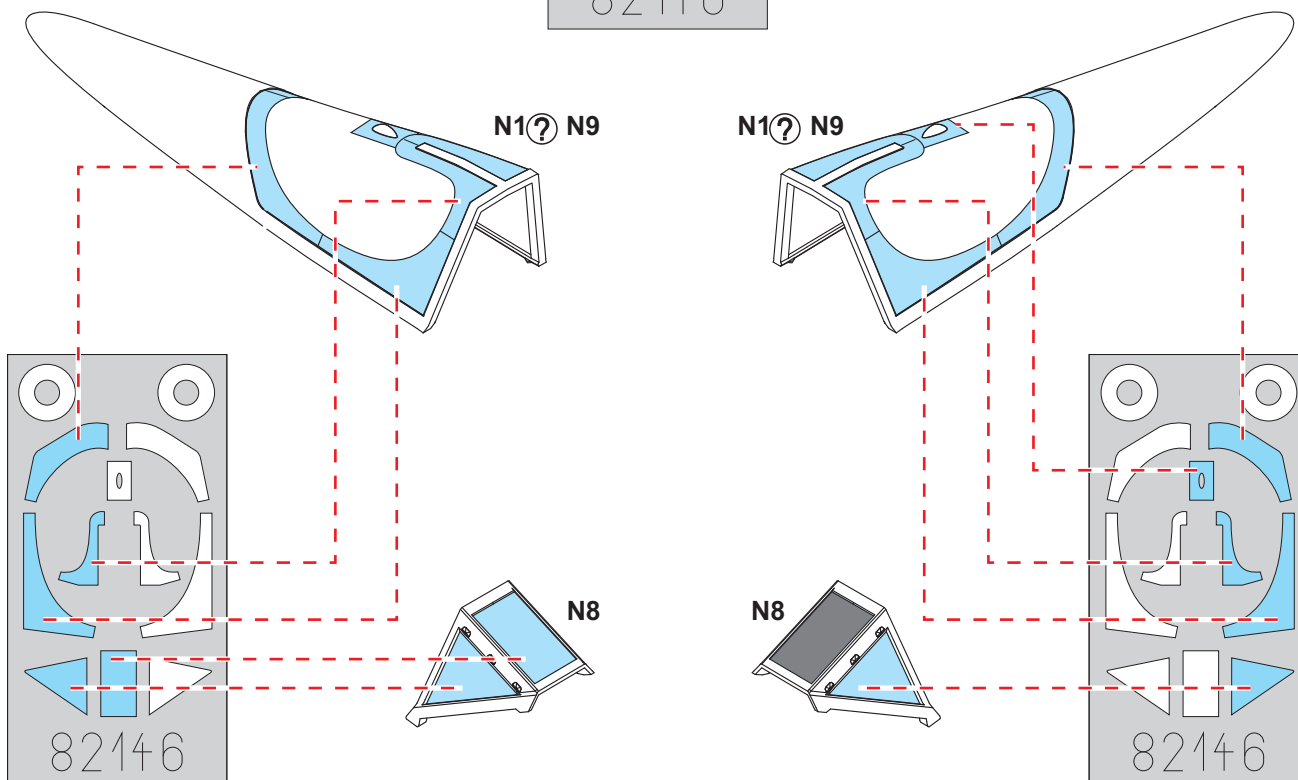
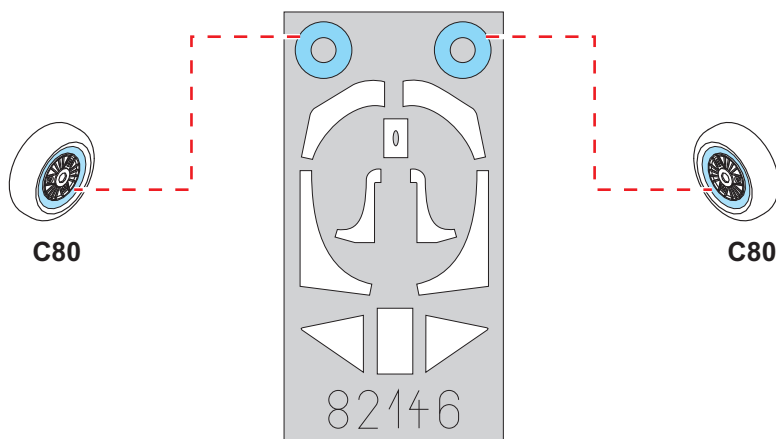
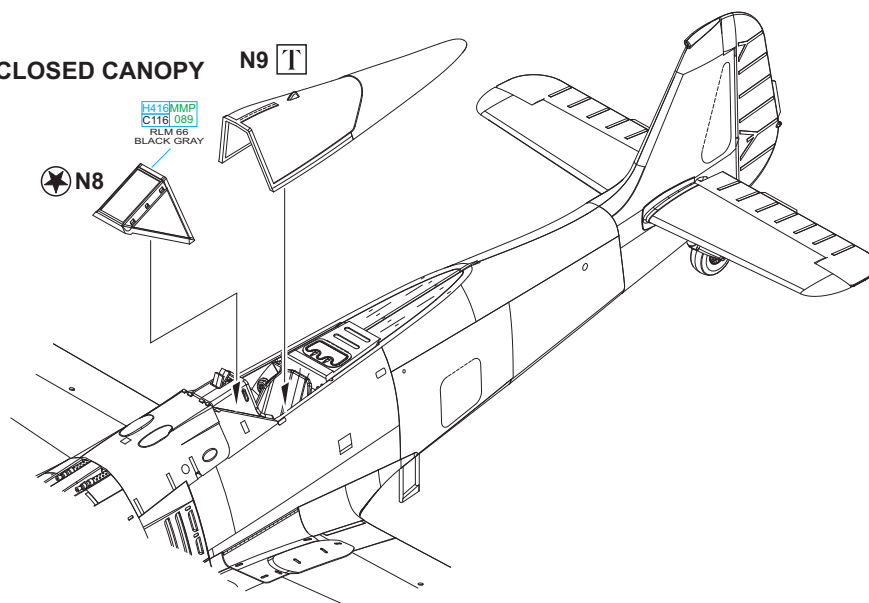

A W. Nr. 0125228, flown by Ofw. Erwin Leibold, Stab I./JG 26, St. Omer-Arques, France, July 1942

German Jagdgeschwader 26 ace Erwin Leibold got his eleventh and final kill in the afternoon of July 12th, 1942, when he shot down a reconnaissance Mosquito PR Mk.II over Licques in France, on a mission to photograph Strasbourg and Ingolstadt. Both British crewmen died. The fate of their conqueror was sealed only two weeks later when Ofw. Leibold took part in I./JG26 attacks against the Biggin Hill Wing, operating over France. The aircraft flown by Leibold, flying as wingman of the Gruppe CO Hptm. Seifert, exploded after being intercepted by a Spitfire. The pilot was spotted floating to the ground by parachute, but a search for him turned up nothing. The standard camouflaged aircraft assigned to Staff I. Gruppe were marked in a non-standard way, with letters or initials of its pilots. The letter 'L' (Leibold) is coupled with the designation of the aircraft within the Staffel in the form of a chevron and carries eleven kill markings on the yellow rudder. The letter 'L' (Leibold) is coupled with the designation of the aircraft within the Staffel in the form of a chevron and carries eleven kill markings on the yellow rudder.

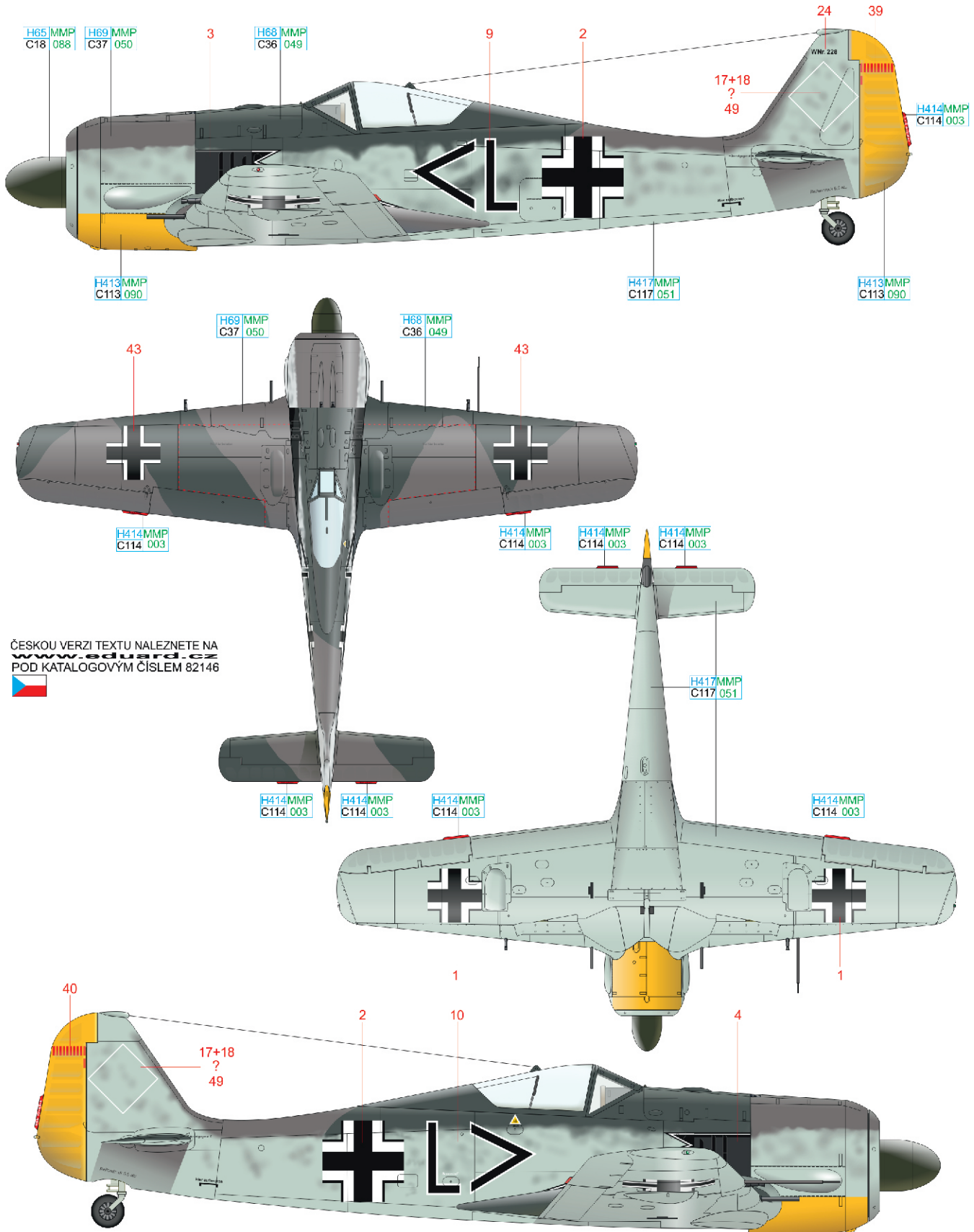

ČESKOU VERZI TEXTU NALEZNETE NA www.eduard.cz POD KATALOGOVÝM ČÍSLEM 82146



RLM 70	H65 MMP C18 088	RLM 04	H413 MMP C113 090	RLM 23	H414 MMP C114 003
RLM 74	H68 MMP C36 049	RLM 75	H69 MMP C37 050	RLM 76	H417 MMP C117 051

B W. Nr. 0125281, flown by Oblt. Siegfried Schnell, CO of 9./JG 2, Théville, France, June 1942

Siegfried 'Wumm' Schnell, a native of today's Polish Sulęcín (then Zeilenzig in Brandenburg) joined the ranks of the Luftwaffe in 1936 and at the beginning of the Second World War he served with JG 2. His first kill was in combat over France on May 14th, 1940, others followed over Britain and against English and American pilots over western Europe. After being assigned to JG 54, he first served with its III. Gruppe and was on February 1st, 1944 made CO of IV. Gruppe. While serving in this function, he was shot down on February 25th, 1944 over Narva by a Soviet fighter, this proving to be a fateful encounter. For his combat results, he was awarded on July 9th, 1941 the Knight's Cross with Oak Leaves. In Second World War downed 93 enemy aircraft. The Fw 190A-2 flown by Oblt. Schnell carried the standard camouflage scheme applied to Luftwaffe fighters consisting of RLM 74/75/76. The yellow rudder carried 64 kill markings. The sides of the fuselage and engine cowl carries the so-called 'Adlerflügel'.

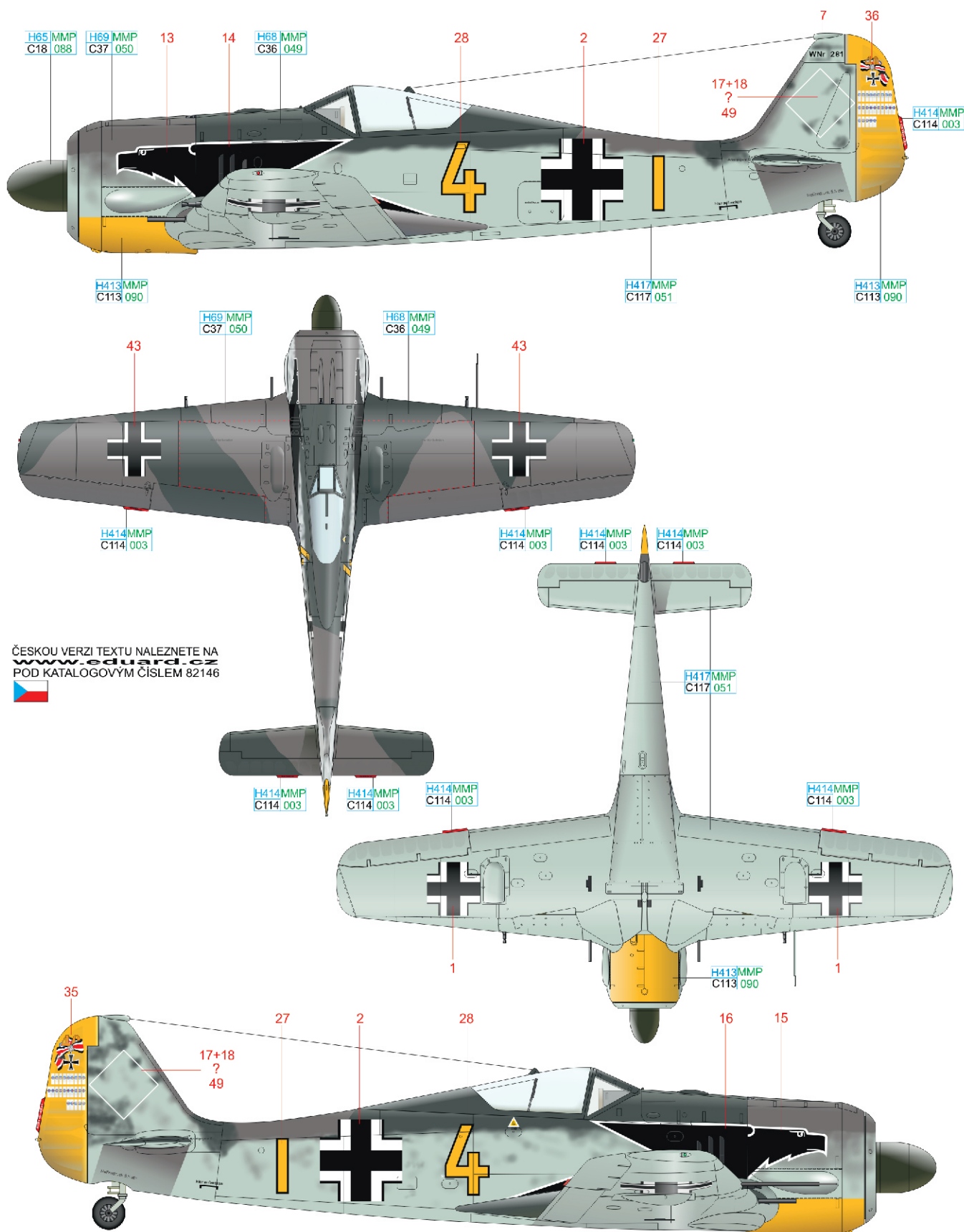

ČESKOU VERZI TEXTU NALEZNETE NA
www.eduard.cz
 POD KATALOGOVÝM ČÍSLEM 82146



RLM 70	H65 MMP C18 088	RLM 04	H413MMP C113 090	RLM 23	H414MMP C114 003
RLM 74	H68 MMP C36 049	RLM 75	H69 MMP C37 050	RLM 76	H417MMP C117 051
				BLACK	H12 MMP C33 047

C W. Nr. 0122125, flown by Oblt. Max Buchholz, CO of 5./JG 1, Katwijk, the Netherlands, Summer 1942

Max Buchholz was born on November 3rd, 1912 in Zerbst and at the beginning of the war he served with Jagdgeschwader 3. With this unit, he saw combat over France and over Great Britain, as well as in Operation Barbarossa (the invasion of the Soviet Union). At the beginning of October 1941, I./JG3 was sent for some R and R to Germany. After that, it was moved to the Netherlands and on January 6th, 1942, was redesignated II./JG1. Oblt. Buchholz was given command of the 6th Staffel. On February 12th, 1942, he gained his 28th victory over a British Blenheim in a mission to cover the move of the battle cruisers Scharnhorst and Gneisenau, together with the heavy cruiser Prinz Eugen, from Brest to German harbours. From the middle of the year up to the end of the war he served in administrative duties. He died on July 19th, 1996, in Germany. The tip of the red spinner of Buchholz's aircraft carries a thin white spiral, and otherwise is camouflaged in RLM 74/75/76. The marking of the Commander of the 5th Staffel in the form of a black numeral is supplemented by the II. Gruppe insignia (the horizontal bar in the Staffel colour), and also by the personal marking of the gull in flight below the cockpit. The engine cowling bears the red 'Tatzelwurm' - the 5./JG1 badge.

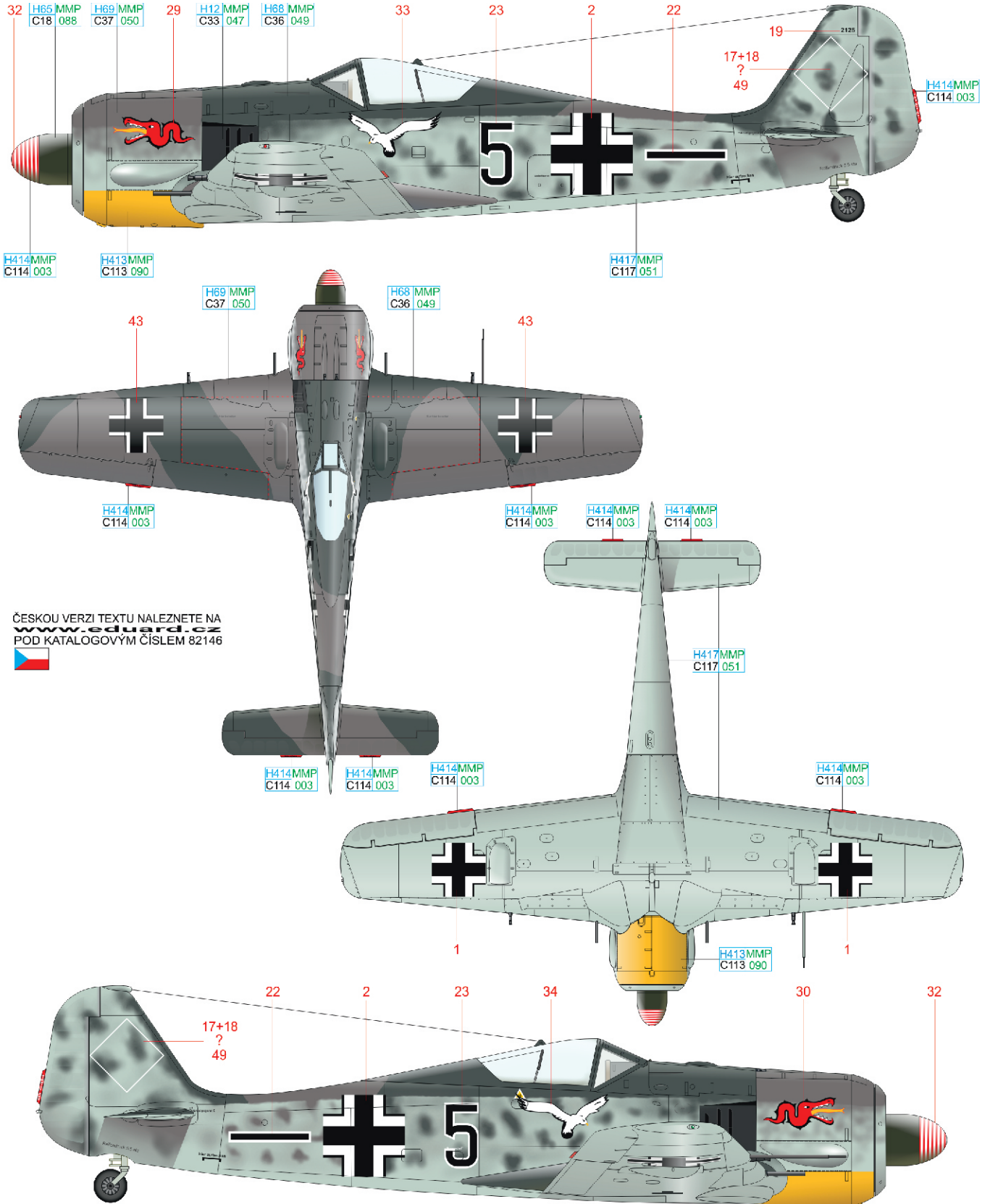

ČESKOU VERZI TEXTU NALEZNETE NA www.eduard.cz POD KATALOGOVÝM ČÍSLEM 82146



RLM 70	H65 MMP C18 088	RLM 04	H413MMP C113 090	RLM 23	H414MMP C114 003
RLM 74	H68 MMP C36 049	RLM 75	H69 MMP C37 050	RLM 76	H417MMP C117 051
			BLACK	H12 MMP C33 047	

E flown by Oblt. Egon Mayer, CO of 7./JG 2, Théville, France, Summer 1942

Egon Mayer was born on August 19th, 1917 in Konstanz and he joined the Luftwaffe in 1937. In December 1939, he was assigned to Jagdgeschwader 2 after undergoing training, and served with this unit through the French campaign and into the Battle of Britain. Throughout this period of time, he served as a unit member, from June 10th, 1941 he became CO of the 7th Staffel and was the CO of the entire III. Gruppe from November 1942. By that time, he had accumulated 52 kills. On November 23rd, he brought down his first American four-engine heavy bomber. Together with George-Peter Eder, he would work out the tactic of head on attacks against American bomber formations. On July 1st, 1943, he was made Commanding Officer of the entire JG 2. On March 2nd, 1944, he led a formation of JG 2 fighters in an intercept of American bombers over Montmédy and was shot down and killed by escorting P-47s. He was posthumously awarded the Sword to his Knight's Cross. The 7th Staffel JG 2 badge is carried on the cowling of this standard camouflaged Fw 190 flown by Egon Mayer. The yellow rudder carries 44 kill markings in the form of French and British roundels. The former markings of the aircraft were sprayed over with RLM 74 Graugrün.

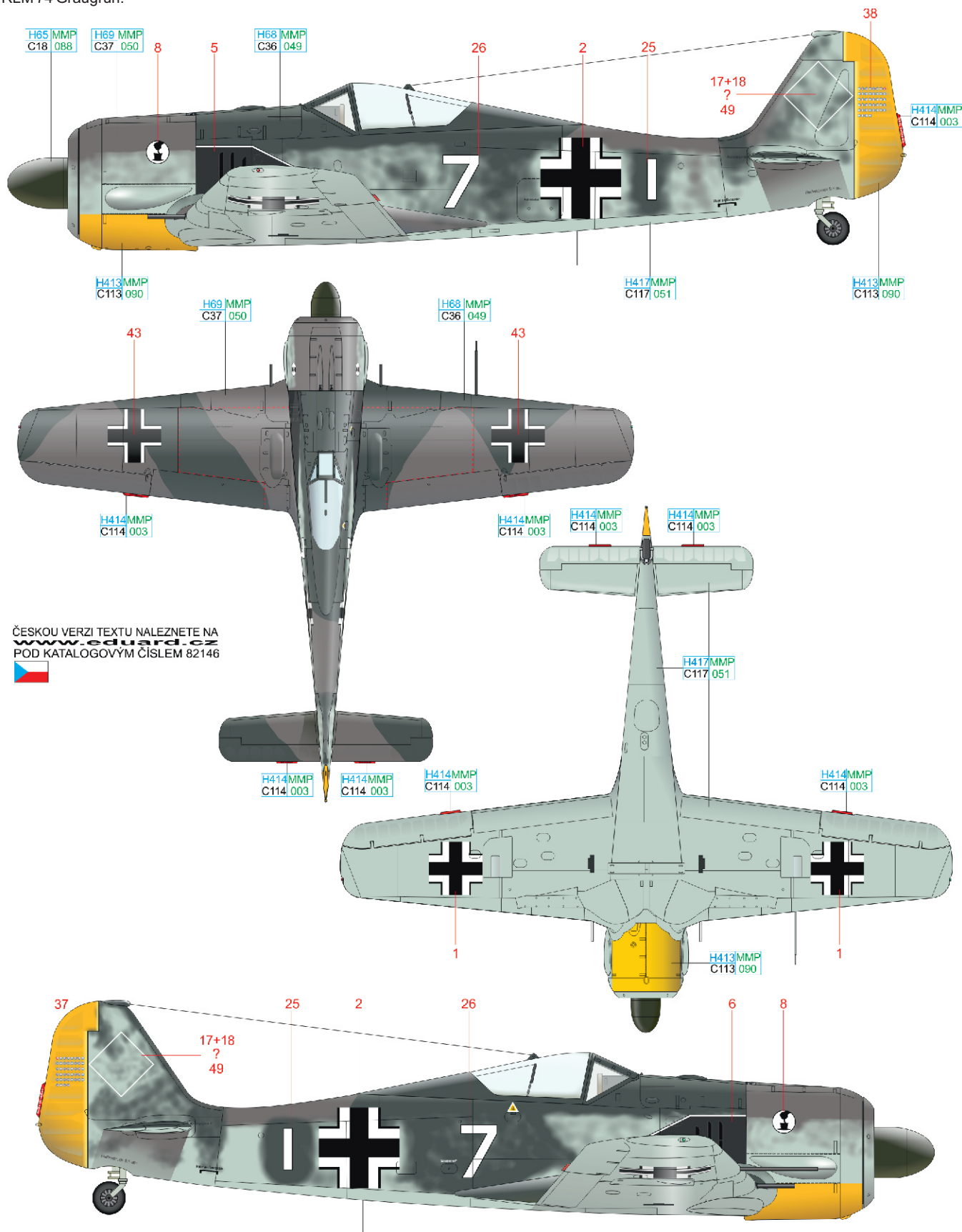

ČESKOU VERZI TEXTU NALEZNETE NA www.eduard.cz POD KATALOGOVÝM ČÍSLEM 82146



RLM 70 H65 MMP C18 088 RLM 04 H413 MMP C113 090

RLM 74 H68 MMP C36 049 RLM 75 H69 MMP C37 050

RLM 76 H417 MMP C117 051 RLM 23 H414 MMP C114 003

eduard

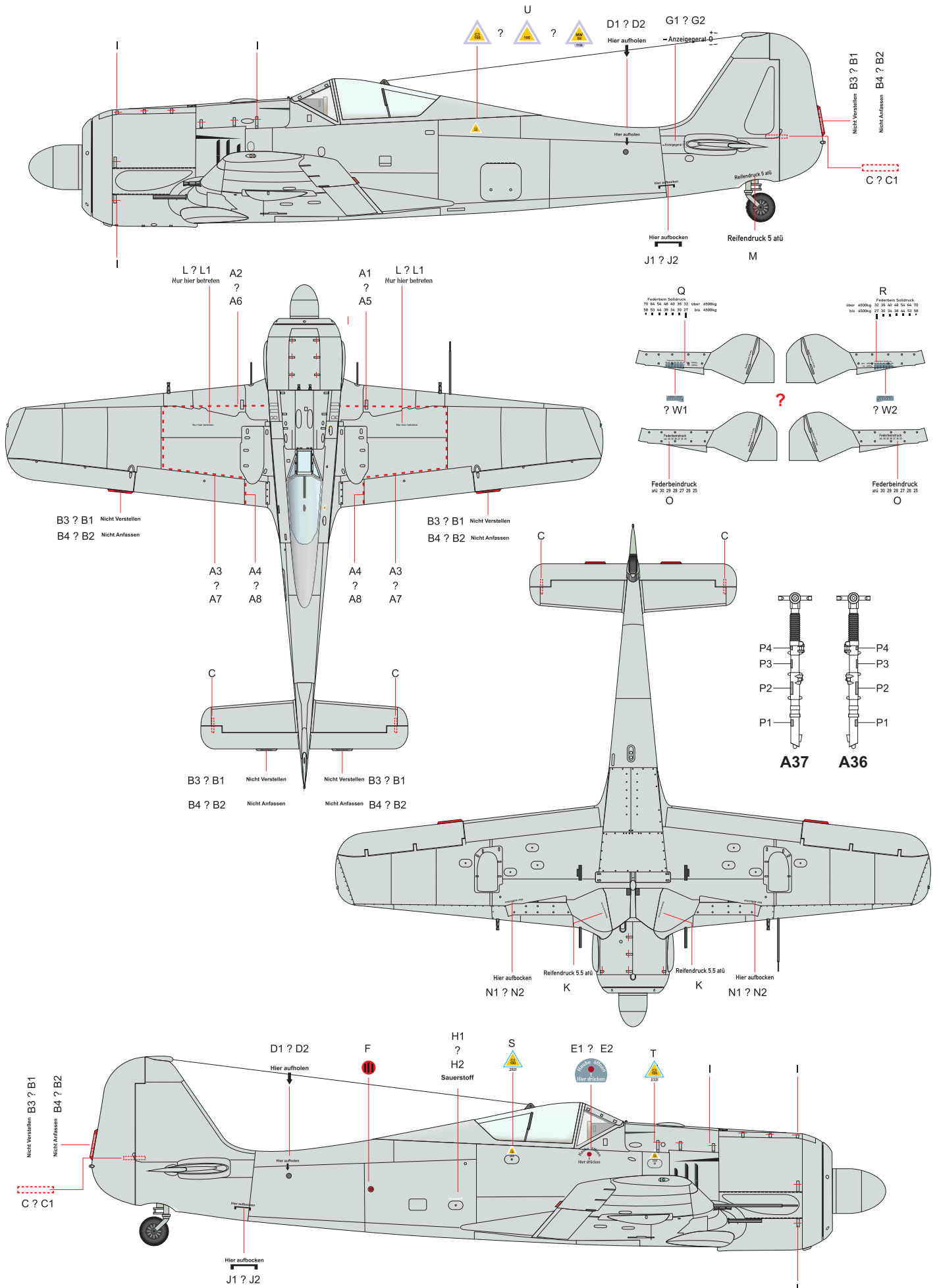

Fw 190A-2

1/48

#82146

ProfiPACK
edition

RELATED PRODUCTS:

- FE863 Fw 190A seatbelts STEEL 1/48 (PE-Set)
- 648356 Fw 190A wingroot gun bays 1/48 (Brassin)
- 648366 Fw 190A propeller 1/48 (Brassin)
- 648371 Fw 190A control surfaces early 1/48 (Brassin)
- 648373 Fw 190A Pitot tubes early 1/48 (Brassin)
- 648379 Fw 190A-2 undercarriage legs BRONZE 1/48 (Brassin)
- 648381 Fw 190A exhaust stacks 1/48 (Brassin)

eduard

