

# Spitfire Mk.IIa

eduard

1/48 Scale Plastic Model Kit

**ProfiPACK**  
edition



item No. 82153

The Supermarine Spitfire is so iconic airplane, that virtually everyone can recognize it. The service of this elegant fighter spanned remarkable 13 years. It entered the service at the end of biplane era and remained in the frontline use until the jet age.

By the early 30s the RAF was looking for replacement of its ageing Hawker Fury biplane fighters. The need of considerably faster aircraft was obvious, as the racing monoplane floatplanes of that time reached about twice the speed of the Fury. One of the most successful designers of the racing floatplanes was Reginald J. Mitchell. His Supermarine S.6B raised the world speed record to 407 mph (655 km/h) on September 20, 1931 and British Air Ministry, under influence of such achievement, issued the specification F.7/30 in October 1931. Although it called for modern pursuit airplane capable of at least 250 mph (400 km/h), seven out of eight entries were biplanes. The only monoplane proposal was Mitchell's Supermarine 224, but the design with a gull wing, fixed undercarriage and Rolls-Royce Goshawk engine was a disappointment because of the lack of speed and poor rate of climb. After that the RAF chose the Gloster Gladiator biplane as the winner.

#### From disillusion to success

The fiasco with Type 224 did not prevent Mitchell from further work. He had already numerous changes in mind, but later persuaded the Supermarine company to fund the work on completely new design Type 300 using brand new Rolls-Royce PV12 engine, later known as the Merlin. The Air Ministry expressed interest and issued specification F.37/34 on December 28, 1934 to fund the prototype armed with four wing mounted guns. But by early April 1935 Mitchell received the detail of specification F10/35, calling for eight guns. The change was made on cost of bomb provision removal and reduction of the capacity of the fuel tanks to sixty-six gallons. The decision caused the so called "short legs" of the Spitfire, meaning a lack of range and endurance.

The Supermarine Type 300 made its maiden flight on March 5, 1936. The K5054 prototype took off from the Eastleigh Aerodrome with chief test pilot Captain Joseph "Mutt" Summers on controls. After only some eight minutes of the flight the pilot was so impressed, he reportedly said: "Do not change a thing!".

Initial contract to produce 310 Spitfires was signed in June 1936 and the first unit to receive the new fighters during August 1938 was No. 19 Squadron at Duxford. At the time the Great Britain entered the war with Germany (September 3, 1939), the RAF had already taken delivery of 306 Spitfires serving with eleven squadrons. By the beginning of May 1940, a further eight squadrons received Spitfires. Unfortunately, Reginald Mitchell did not live to see the Spitfire serving with the RAF units, as he died on June 11, 1937 at the age of 42. The burden of the Spitfire development was on Joe Smith afterwards.

#### Propellers and engines

The development of Spitfire was ongoing process from very early stage of its service. One of the first major upgrades was change from ineffective two blade fixed-pitch wooden propeller to three-bladed two-pitch metal one starting from 78th production aircraft (and retrofitted to the earlier ones). The move increased the maximum speed, raised the ceiling,

and shortened the take-off run. Starting from May 1939 the Spitfire Mk.IIs changed the power unit, switching from Rolls-Royce Merlin II to Merlin III with the same power 1030 hp (768 kW) but with reliability improvements, allowing the installation of constant speed wide-bladed Rotol propeller. That not only gave the Spitfire, now marked Mk.Ia, substantial improvement in rate of climb, but also made it easier to control.

#### Arming and armouring the Spitfire

The early production Spitfires had no armour protection. As a first measure the laminated glass was added to the windscreen. After that, the upper fuel tank received 3mm thick cover of light alloy, while lower one was protected by the Linatex sandwich (rubber and canvas) and more to it, the steel plate was fitted behind the seat to protect pilot. All that armour added weight, but despite the loss of some speed as a result the later aircraft were better fighters than the early ones.

Regarding the armament of the Spitfire, there was one major pending problem to solve at the time the first Mk. Is were delivered to the RAF during summer 1938: freezing guns at the high altitude. It took until October that year an effective system was introduced, and the gun-heating modification was incorporated in all the Spitfires on production line. Another early change related to the gunsight. The early Spitfires had simple ring-and-bead gunsight, starting from September 1939 the GM2 reflector gunsights were fitted.

The armament consisted of eight 0.303 in (7,7 mm) Browning guns. It was believed to be the best arrangement during mid-30s, but the early war experience proved it inadequate against multi engine bombers with self-sealing fuel tanks. The RAF tried to change for heavier weapons, choosing the French 20mm Hispano-Suiza Type 404 cannons, but the wing installation in Spitfire proved to be troublesome. A small batch of Mk.IIs entered the service with No. 19 Squadron as the Mk.Ib in June 1940, but the cannons proved unreliable. The problems were solved at the end of 1940, paving the way for heavier armament of the later marks.

#### Spitfire Mk.II

The Mk. II was another substantial improvement in the Spitfire development thanks to the more powerful Merlin XII engine rated at 1150 hp (857 kW). The engine also used 100 octanes fuel instead of 87 octanes. Meantime Spitfires Mk. I of No. 54 Squadron were fitted with the new propeller Rotol RX 5/1 during early 1940, which then became standard with Spitfire Mk. II (some received the Rotol RX 5/3 ones with wooden blades instead). The Mk.II was also fitted with pyrotechnical starter Coffman. To fit it under the engine cowling, a small bulge was made on the right side of the nose. The Spitfire Mk.II retained the armament of the Mk.I, while Mk.IIb had the same weaponry as the Mk.Ib.

Apart from the rather inadequate firepower for the time and some other shortages, the Spitfire Mk. I and Mk. II proved to be extremely valuable fighter. There were 1567 of all Mk. Is built, Mk. II production added 920 Spitfires.

ATTENTION



UPOZORNĚNÍ



ACHTUNG



ATTENTION



注意



Carefully read instruction sheet before assembling. When you use glue or paint, do not use near open flame and use in well ventilated room. Keep out of reach of small children. Children must not be allowed to suck any part, or pull vinyl bag over the head.



Před započatím stavby si pečlivě prostudujte stavební návod. Při používání barev a lepidel pracujte v dobře větrané místnosti. Lepidla ani barvy nepoužívejte v blízkosti otevřeného ohně. Model není určen malým dětem, mohlo by dojít k požití drobných dílů.

INSTRUCTION SIGNS \* INSTR. SYMBOLS \* INSTRUKTION SINNBILDEN \* SYMBOLES \* 記号の説明

OPTIONAL  
VOLBABEND  
OHNOUTSAND  
BROUSITOPEN HOLE  
VYVRTAT OTVORSYMETRICAL ASSEMBLY  
SYMETRICKÁ MONTÁŽREMOVE  
ODŘÍZNOUTREVERSE SIDE  
OTOČITAPPLY EDUARD MASK  
AND PAINT  
POUŽIT EDUARD MASK  
NABARVIT

PARTS



DÍLY



TEILE



PIÈCES



部品

## PLASTIC PARTS

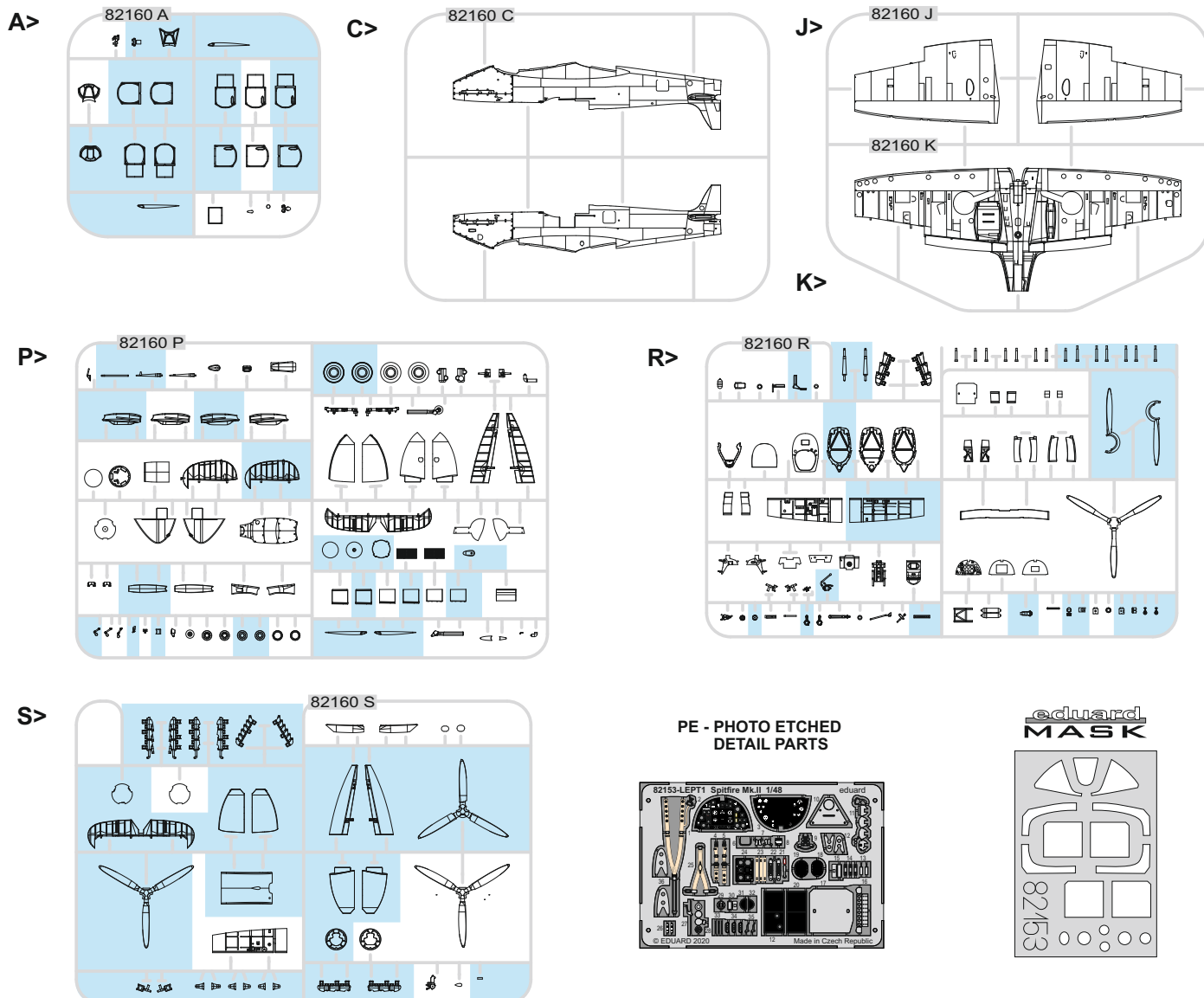

-Parts not for use. -Teile werden nicht verwendet. -Pièces à ne pas utiliser. -Tyto díly nepoužívejte při stavbě. - 使用しない部品

COLOURS



BARVY



FARBEN



PEINTURE



色

GSI Creos (GUNZE)		MISSION MODELS	
AQUEOUS	Mr.COLOR	PAINTS	
H3	C3	MMP-003	RED
H4	C4	MMP-007	YELLOW
H8	C8		SILVER
H12	C33	MMP-047	FLAT BLACK
H33	C81		RUSSET
H51	C11	MMP-063	LIGHT GULL GRAY
H72	C369	MMP-078	DARK EARTH
H74	C368	MMP-080	SKY
H77	C137	MMP-040	TIRE BLACK
H90	C47		CLEAR RED
H94	C138		CLEAR GREEN

GSI Creos (GUNZE)		MISSION MODELS	
AQUEOUS	Mr.COLOR	PAINTS	
H330	C361	MMP-077	DARK GREEN
H335	C363	MMP-094	MEDIUM SEAGRAY
H417	C117	MMP-051	LIGHT BLUE
	C362	MMP-093	OCEAN GRAY
	C364	MMP-079	AIRCRAFT GRAY-GREEN
Mr.METAL COLOR		METALLICS	
	MC214	MMM-001	DARK IRON
	MC218	MMM-003	ALUMINIUM
Mr.COLOR SUPER METALLIC		METALLICS	
	SM201	MMC-001	SUPER FINE SILVER



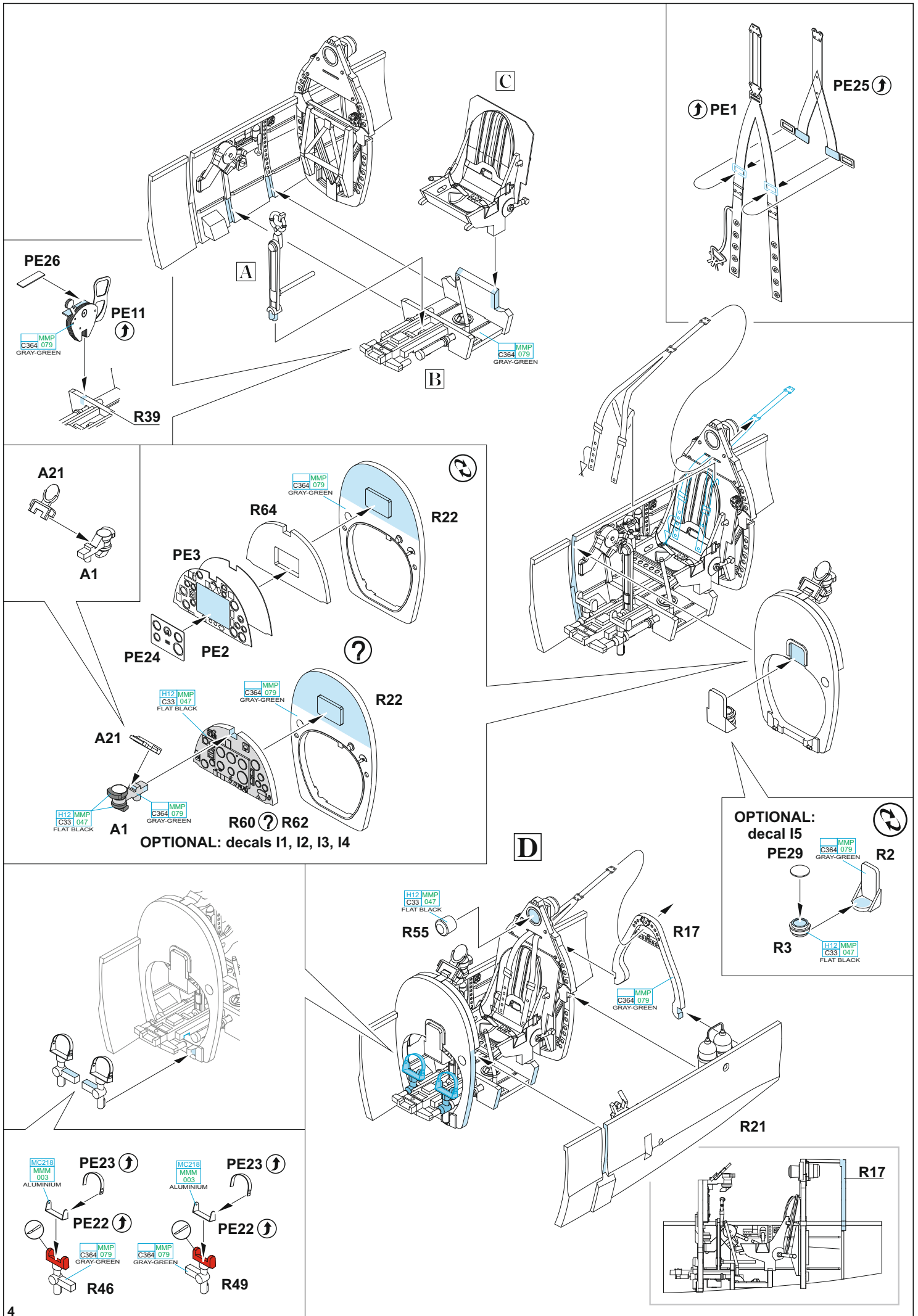

7 FOR CLOSED CANOPY ONLY

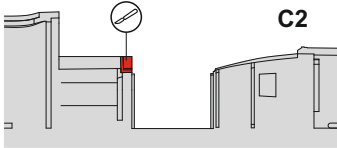

C2

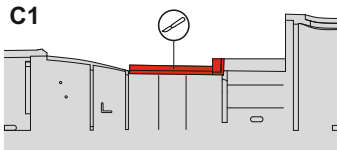

C1

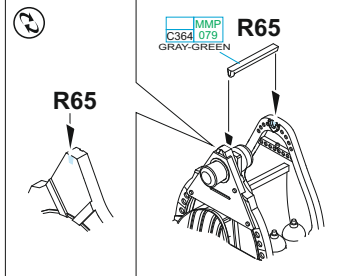

R65

R65

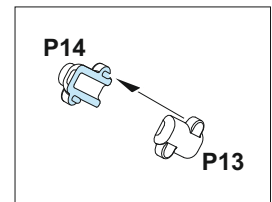

P14

P13

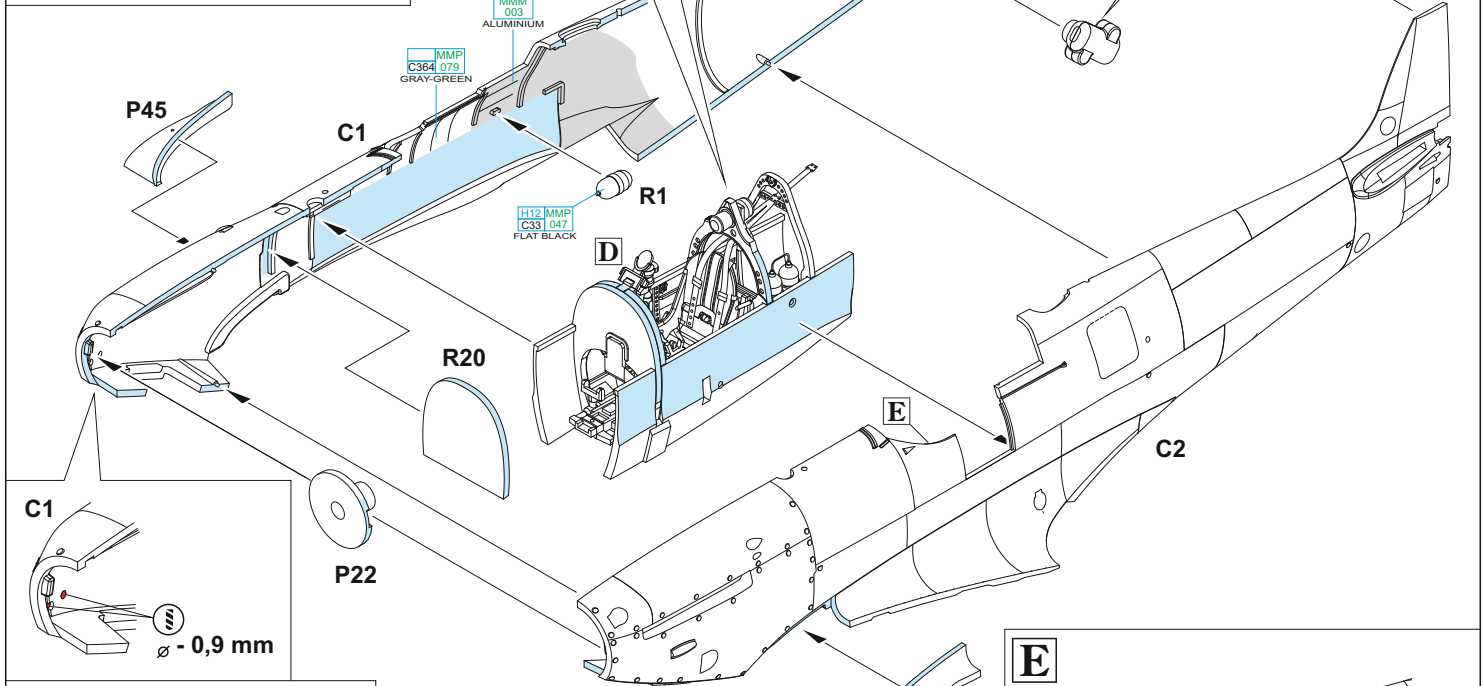

P45

C1

R1

R20

D

E

C2

P22

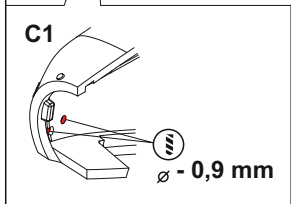

C1

∅ - 0,9 mm

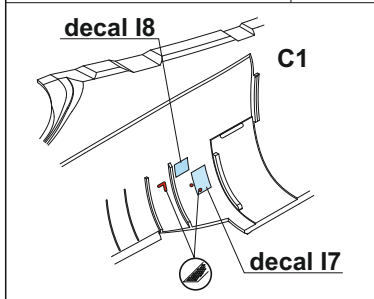

decal I8

C1

decal I7

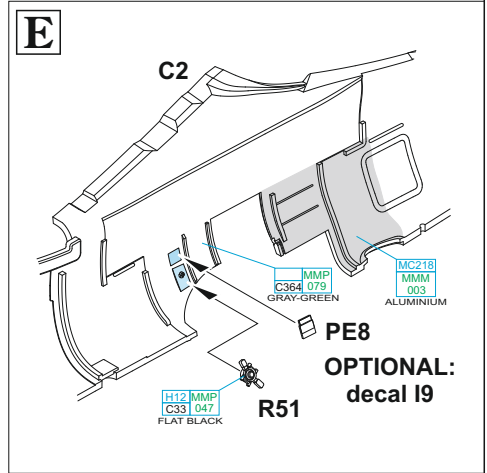

E

C2

P44

∅ - 1 mm

R51

PE8  
OPTIONAL:  
decal I9

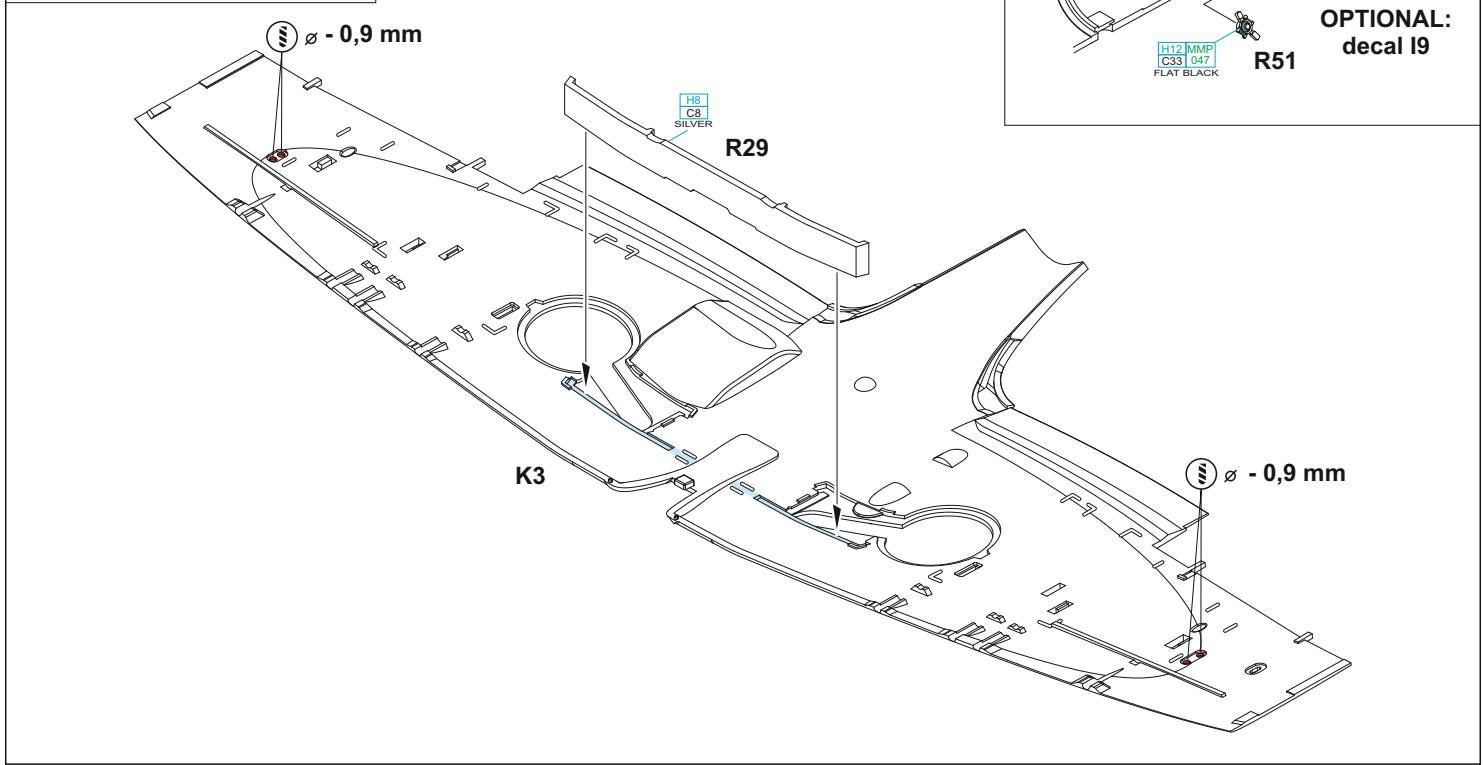

∅ - 0,9 mm

H8 C8 SILVER

R29

K3

∅ - 0,9 mm



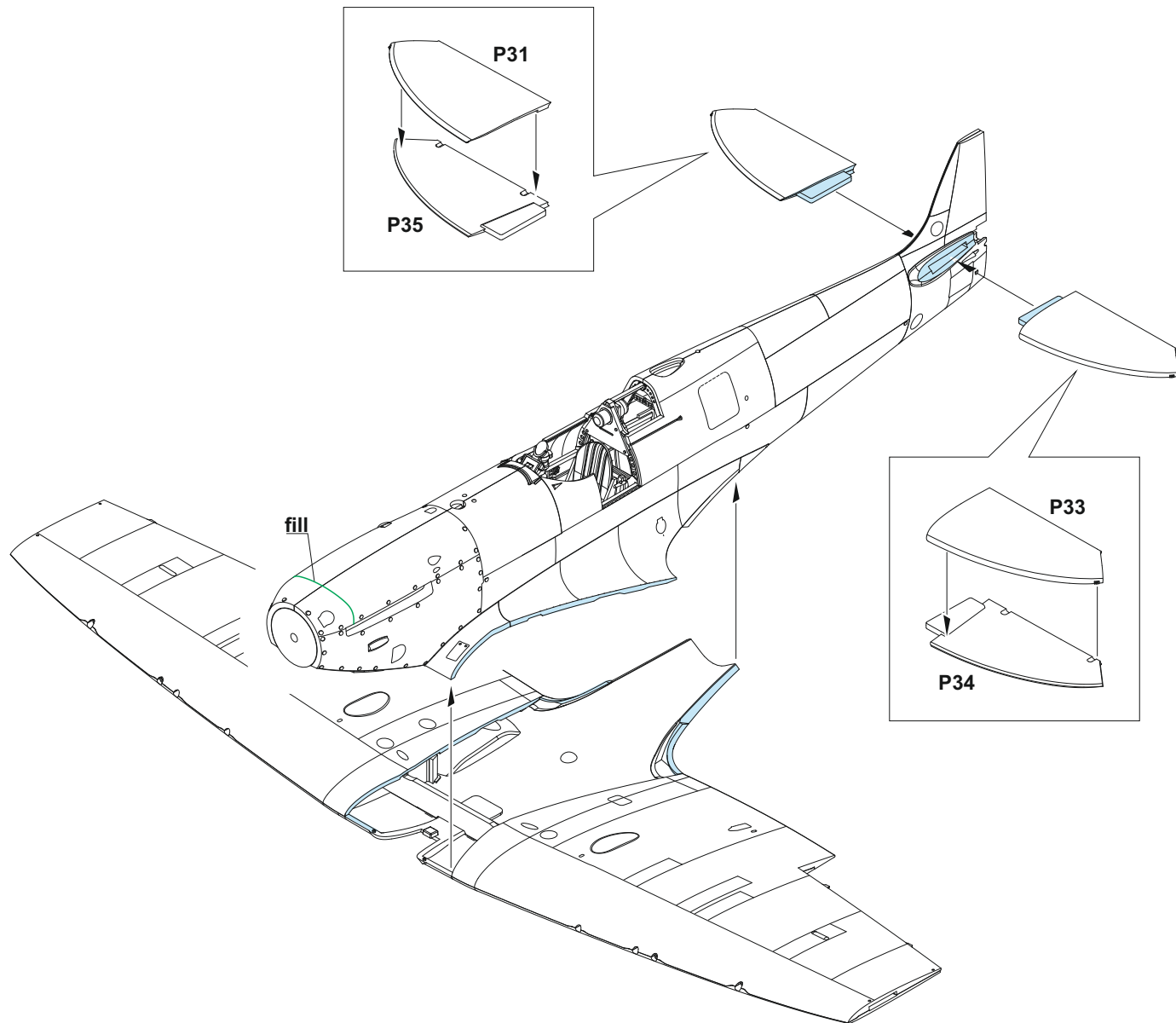

**GLUE PARTS P40 & P41  
ONE BY ONE**

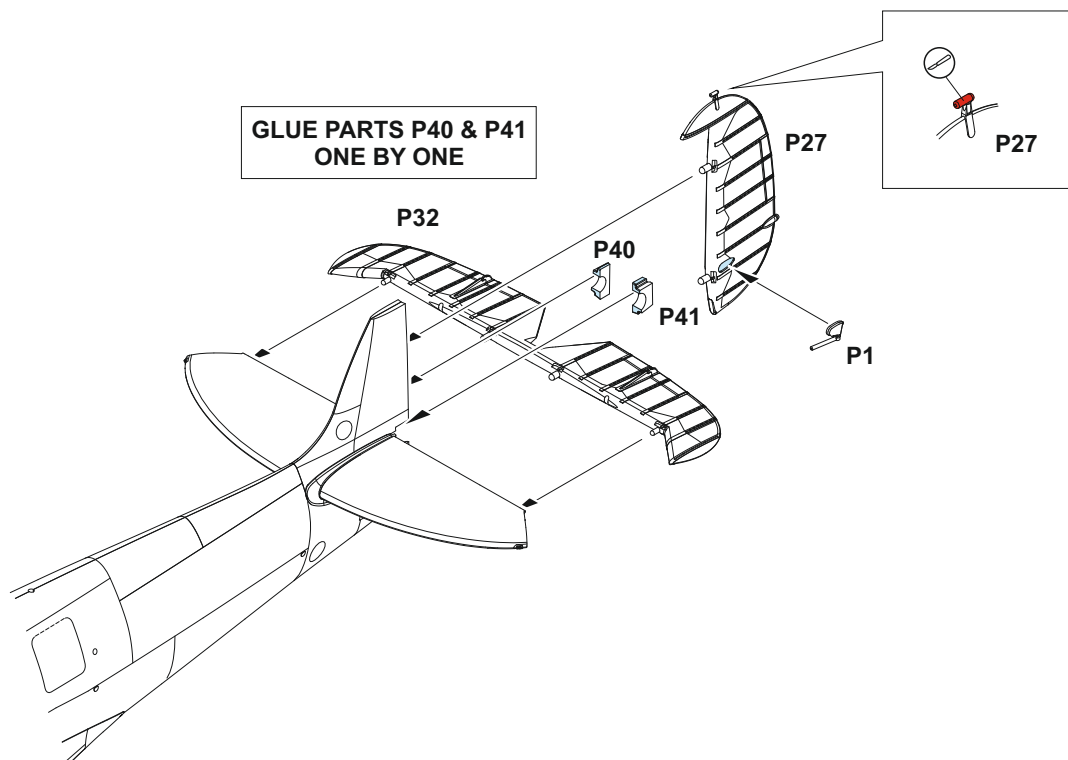

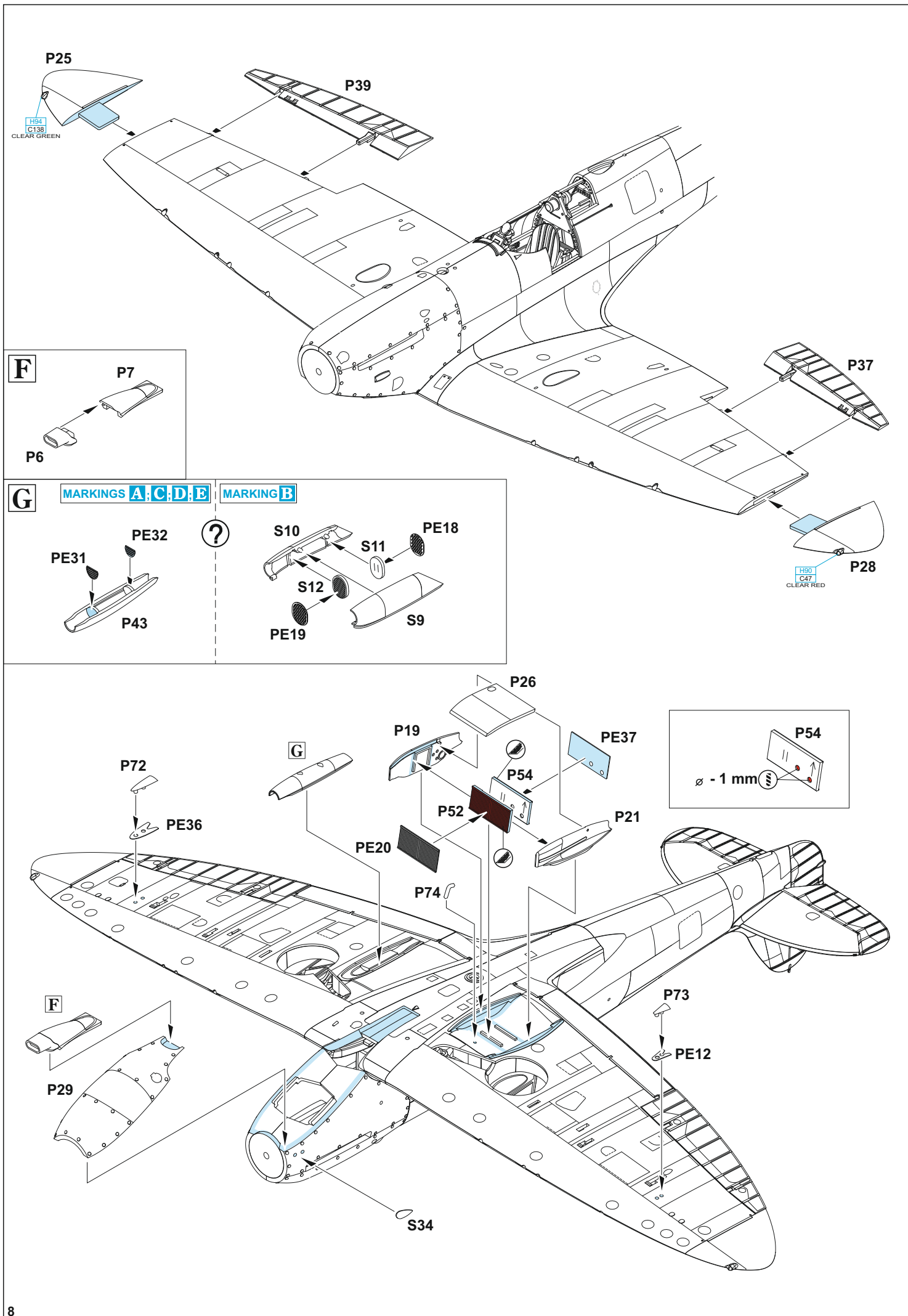

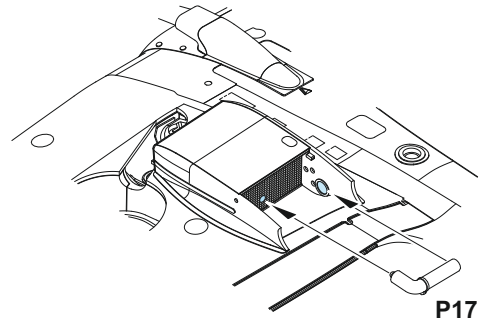
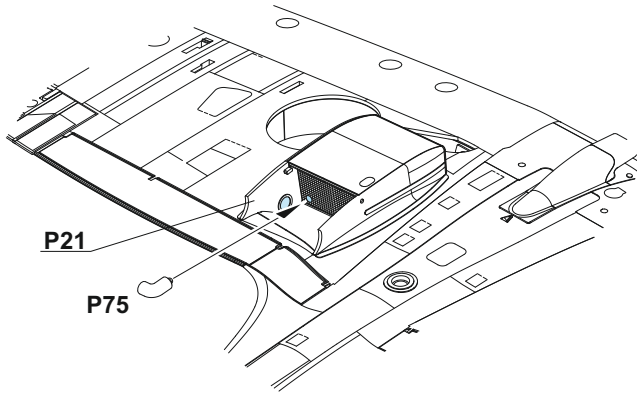

2 pcs.

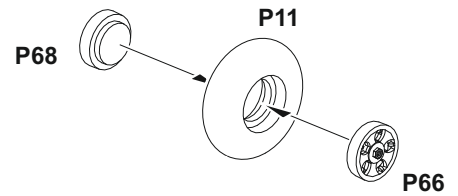
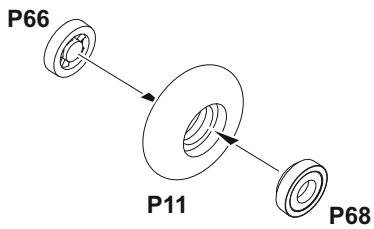
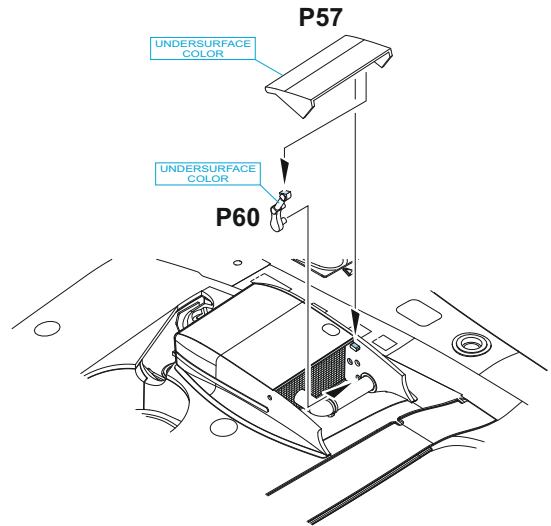
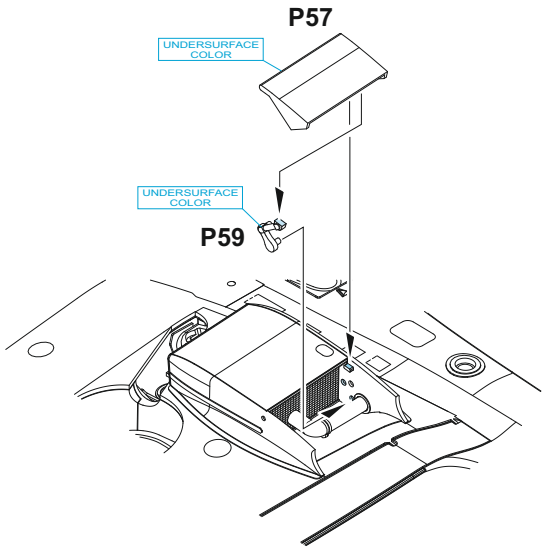
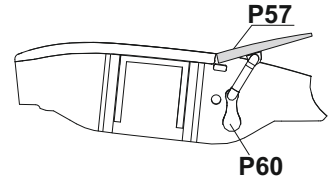
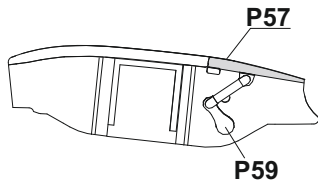
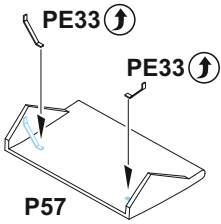

**H**

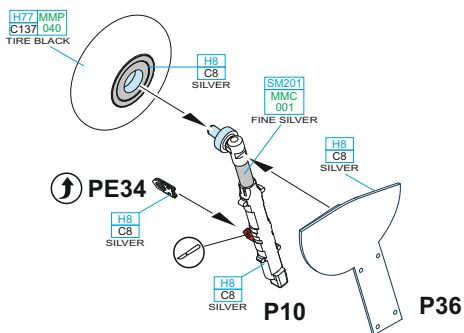

**I**

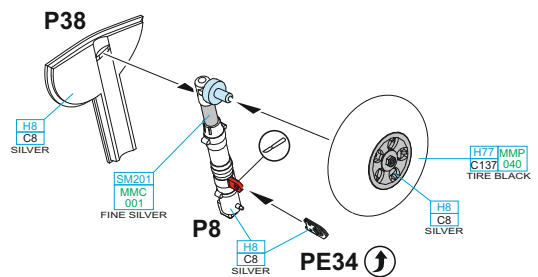

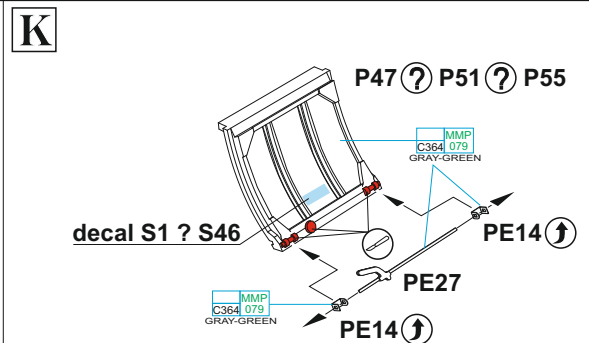
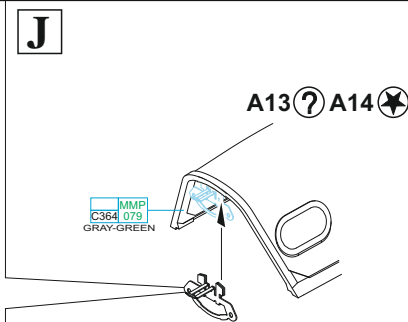
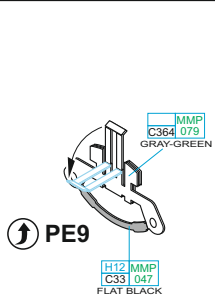
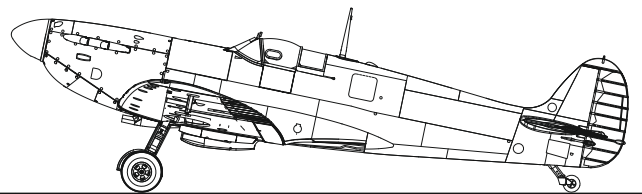
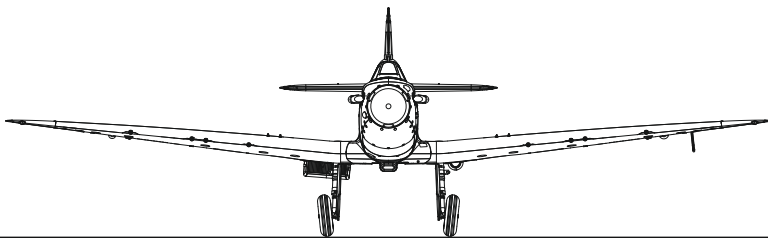
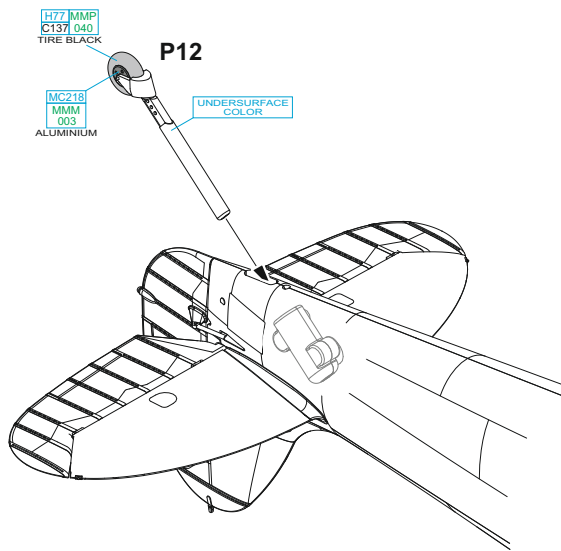
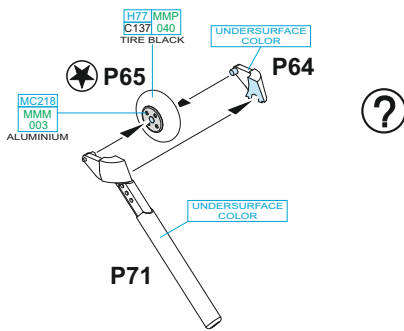
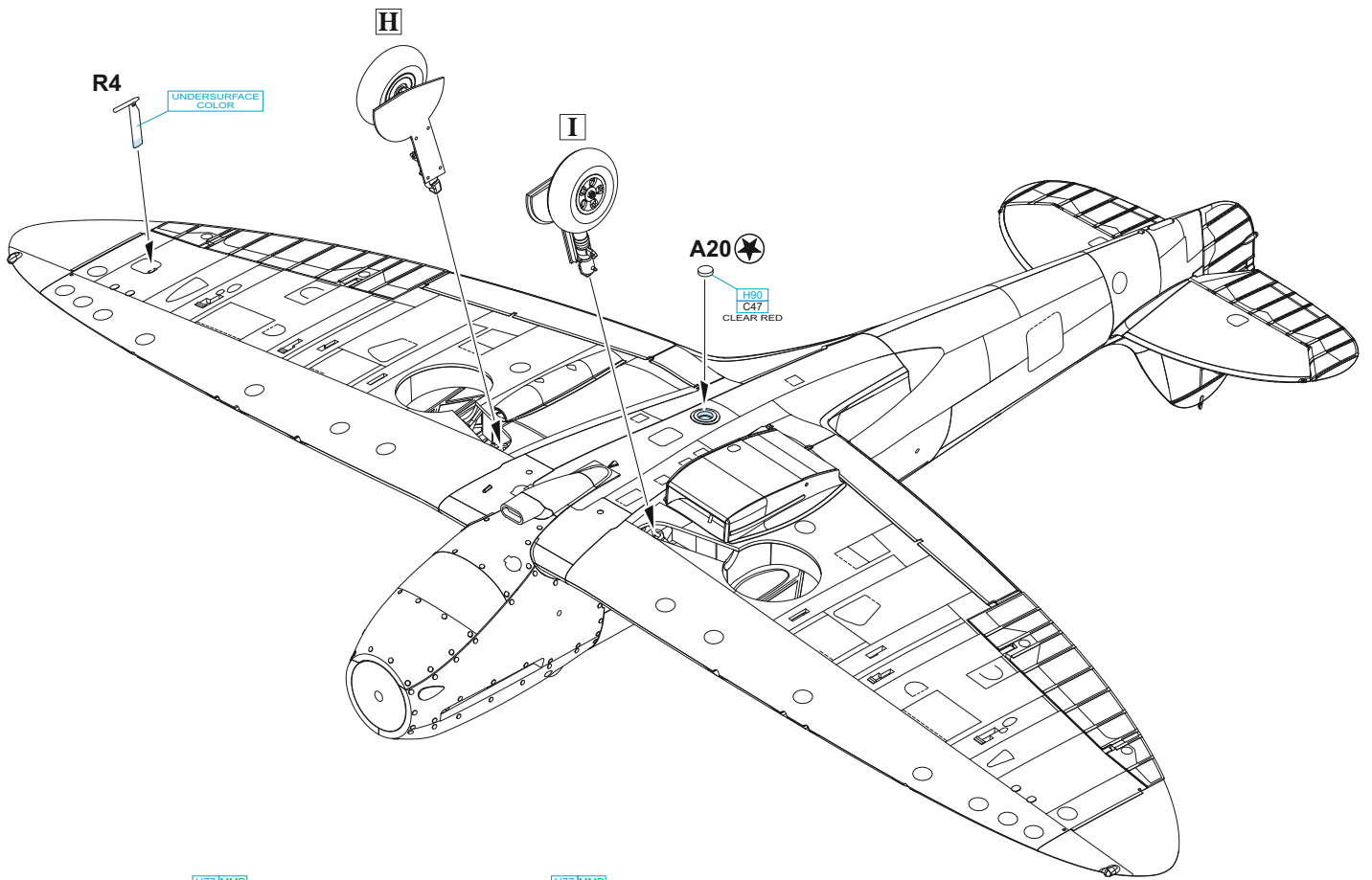

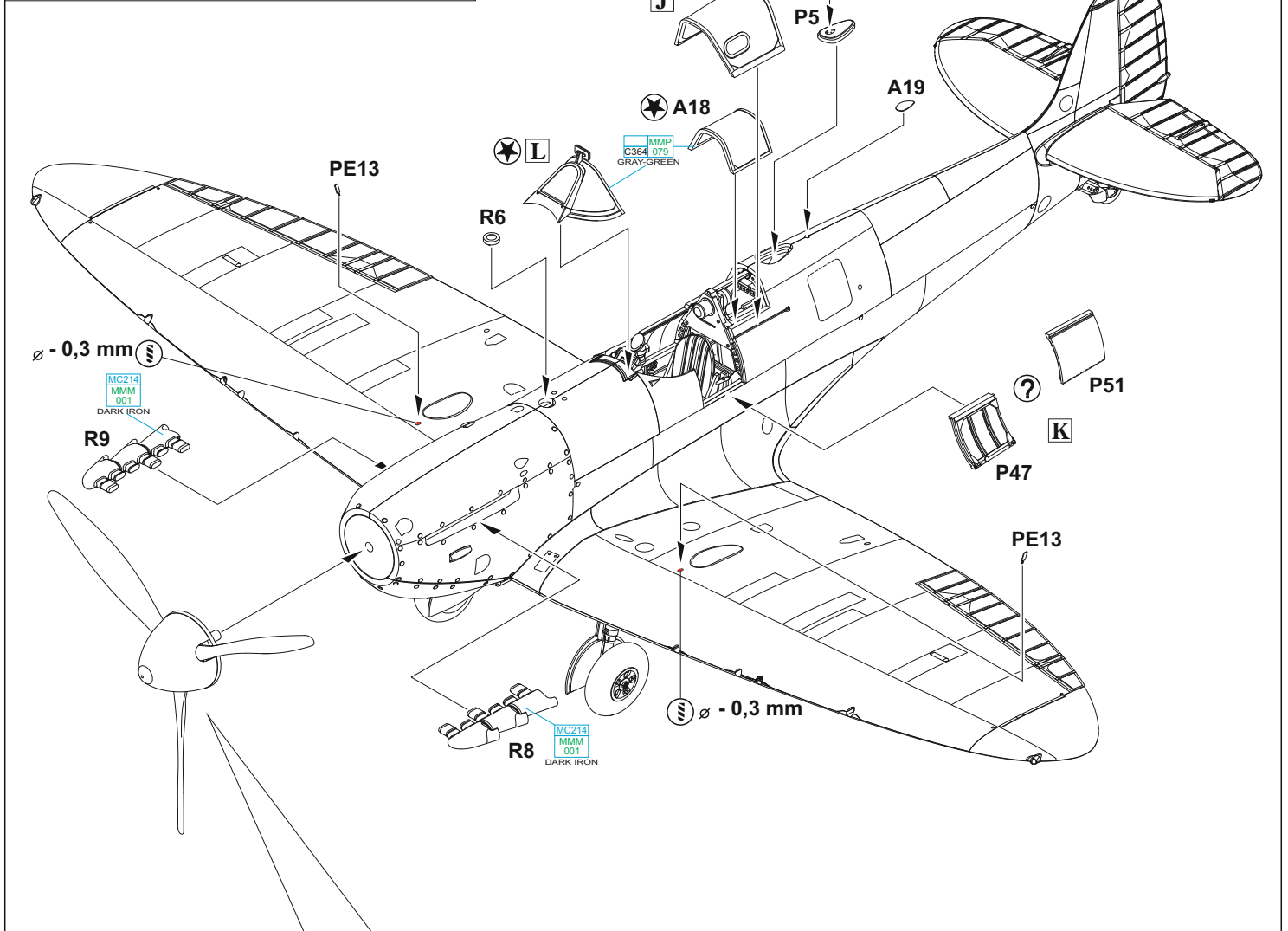
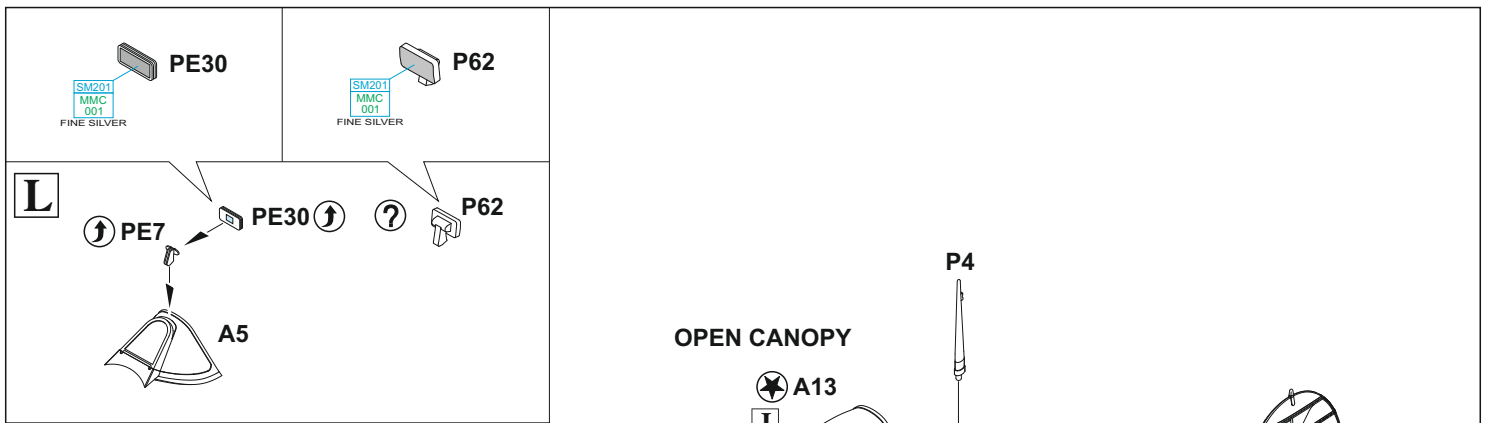

MARKINGS B, D

MARKINGS A, C, E

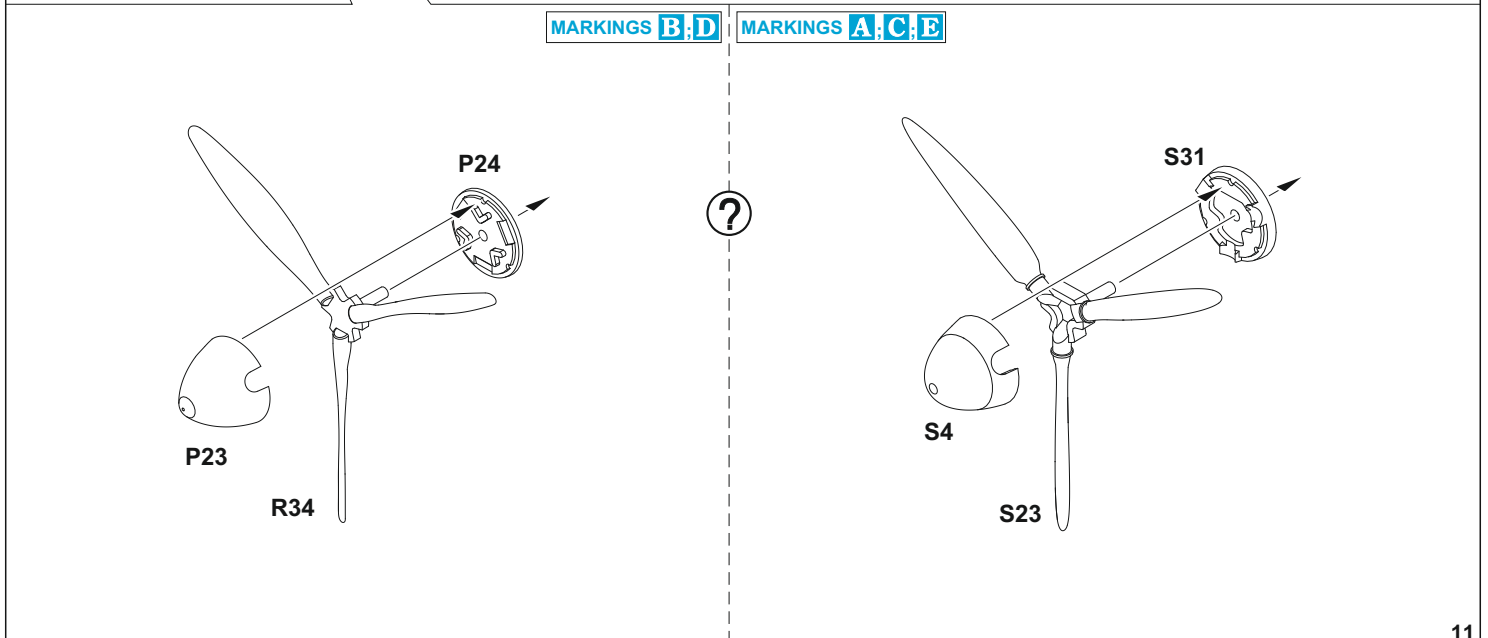



### CLOSED CANOPY

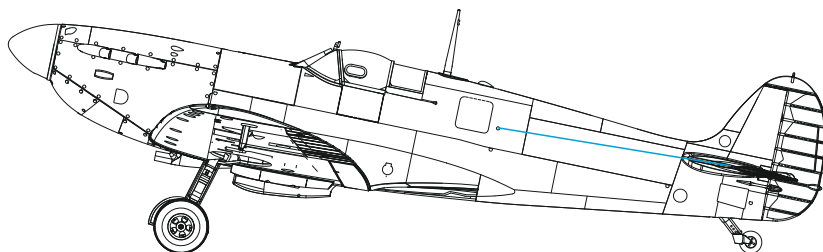
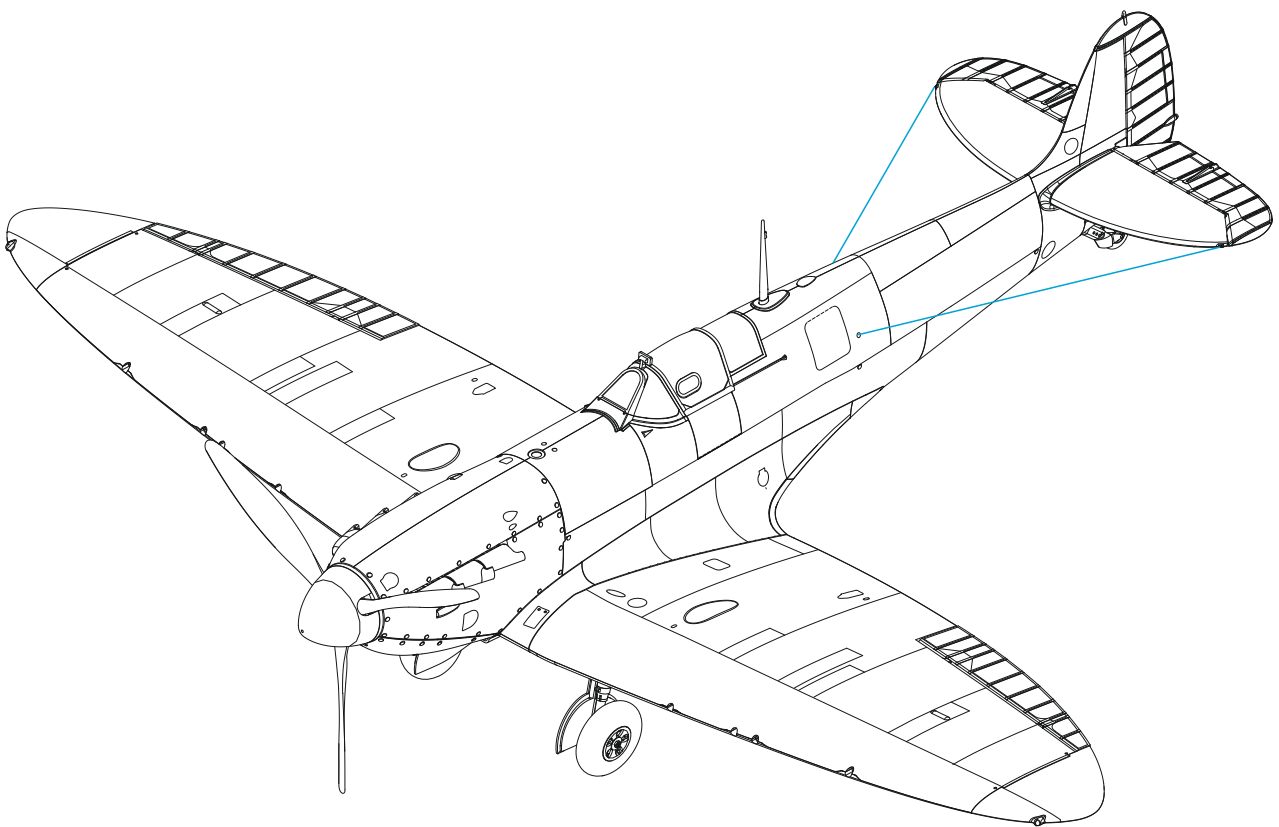
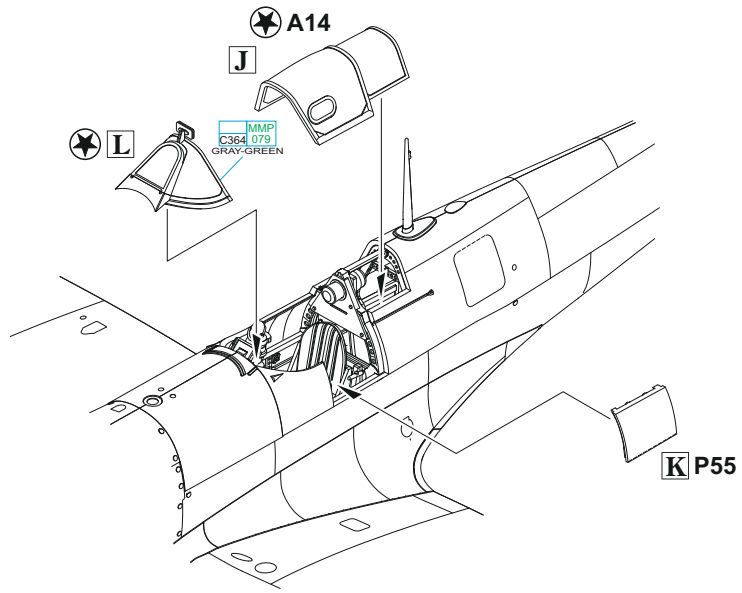

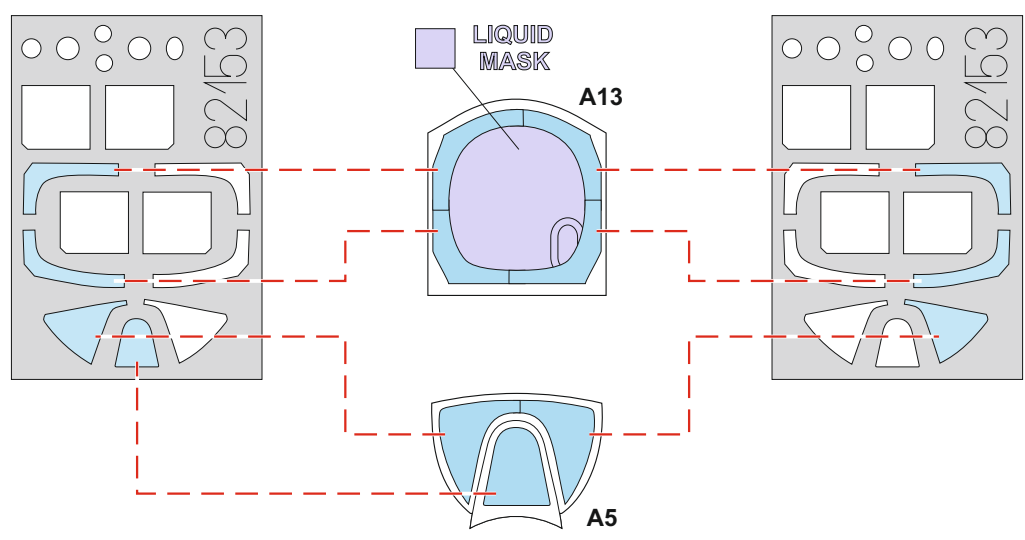
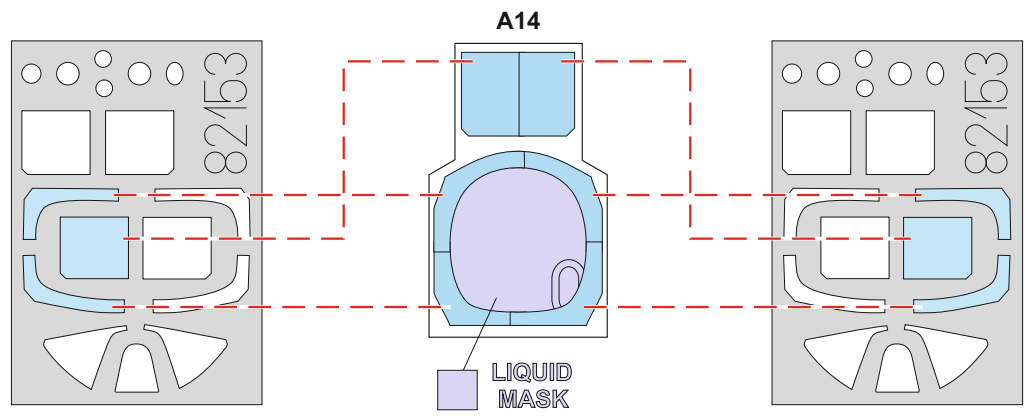
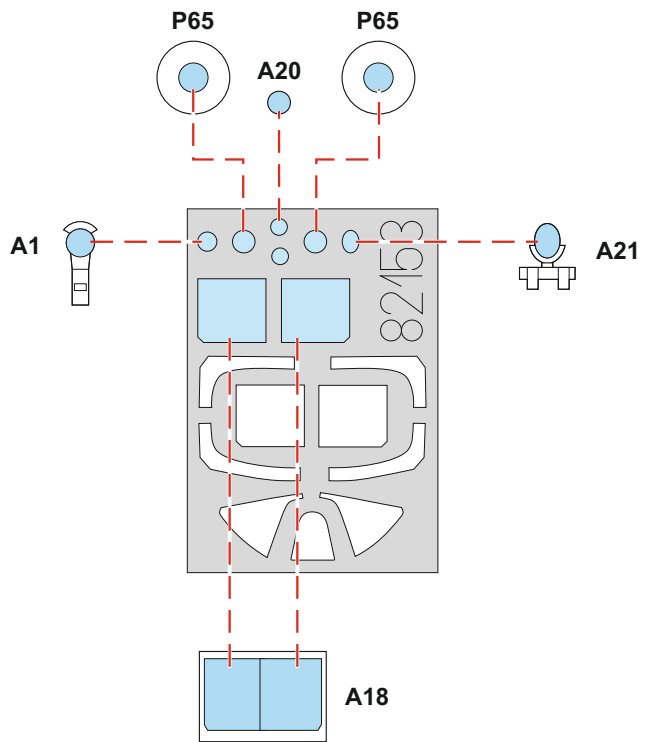

# A P7881, flown by S/Ldr. Michael L. Robinson, CO of No.609 Squadron, RAF Biggin Hill, Great Britain, April 1941

The Spitfire Mk.IIa P7881 carries type B camouflage, although it has an odd serial number. The RotoI spinner is sky-coloured with a red stripe. There is a black B on the lower engine cover and a command pennant of the No.609 Squadron commander is on both sides of the fuselage. The code letters are made in Medium Sea Gray and PR-B are the initials of the base commander, Group Captain Philip Reginald Barwell, who occasionally flew as wingman of "Sailor" Malan. Barwell was accidentally shot down by a Spitfire pilot on July 1st, 1942 above sea, and his body was found on the French coast. Squadron Leader Michael Lister Robinson of No. 609 Squadron recorded with P7881 several victories in May and June 1941. In total, he scored 16 victories, 6 of them in the Battle of Britain. He later led Biggin Hill Wing and Tangmere Wing. He was killed on April 10th, 1942, fighting the Focke-Wulfs of II./JG 26. Along with him died his French friend and wingman Maurice P.C. Choron.

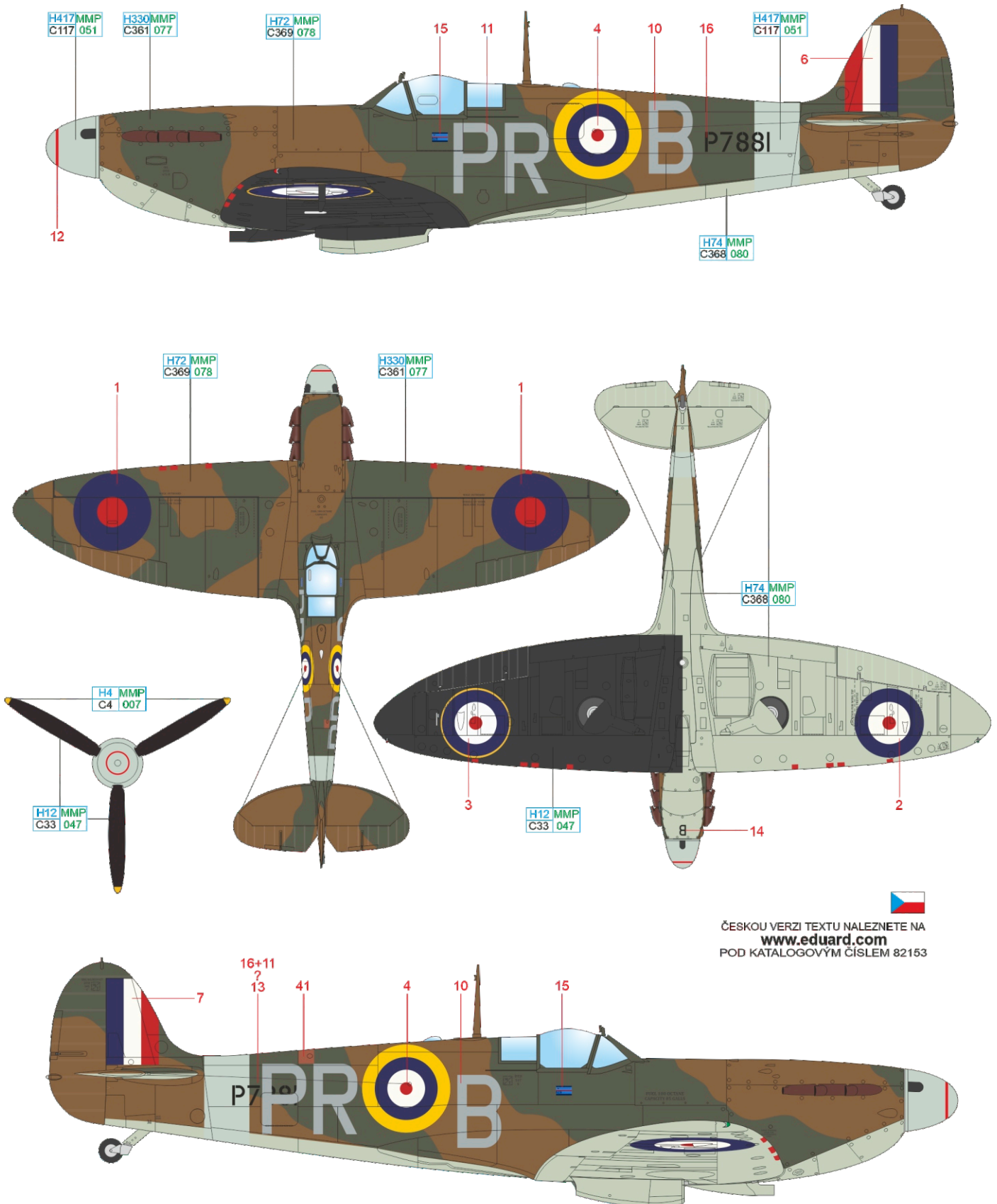

ČESKOU VERZI TEXTU NALEZNETE NA  
[www.eduard.com](http://www.eduard.com)  
 POD KATALOGOVÝM ČÍSLEM 82153

YELLOW	H4 MMP C4 007	BLACK	H12 MMP C33 047	LIGHT BLUEGREEN	H417 MMP C117 051
DARK EARTH	H72 MMP C369 078	DARK GREEN	H330 MMP C361 077	SKY	H74 MMP C368 080

# B P8387, flown by Sgt. Stanislaw Blok, No.315 (Polish) Squadron, RAF Northolt, Great Britain, August 1941

Spitfire Mk.IIa P8387 carries camouflage type A. De Havilland spinner is in Sky color. Nickname BARTY is painted on the fuselage and the code letter H is used for the female name Halina. Spitfire served with No.611 Squadron since May 1941, but in the same month, Canadian ace Alfred Keith Ogilvie DFC of No.609 Squadron, used it to shoot down a Bf 109. In July 1941 the machine was taken over by the Polish No.308 Sqn where the national insignia was added on both sides of the cowling. In July 1941 Polish colleagues from the No.315 Squadron took over P8387. Later on, the machine was converted to the Mk.V version and was used by No.266, No.123 Sqn and 58.OTU. In July 1942, it was written off after a collision with another Spitfire. P8387 flew 872 hours and 30 minutes. Sgt. Stanislaw "Charlie" Blok, among others, flew with this Spitfire with No.315 Squadron. During World War Two, he recorded 5 aerial victories.

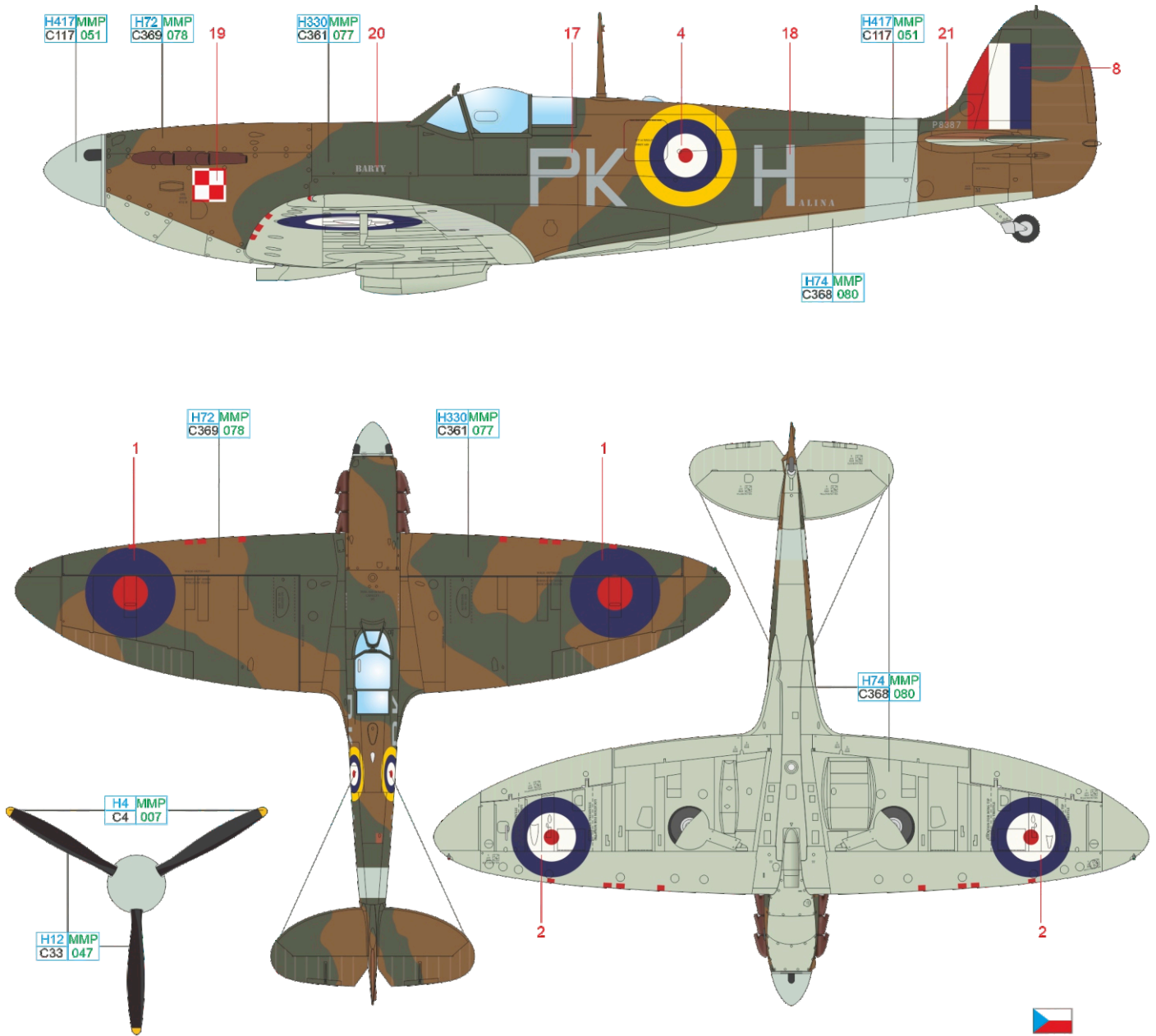

ČESKOU VERZI TEXTU NALEZNETE NA  
**www.eduard.com**  
 POD KATALOGOVÝM ČÍSLEM 82153

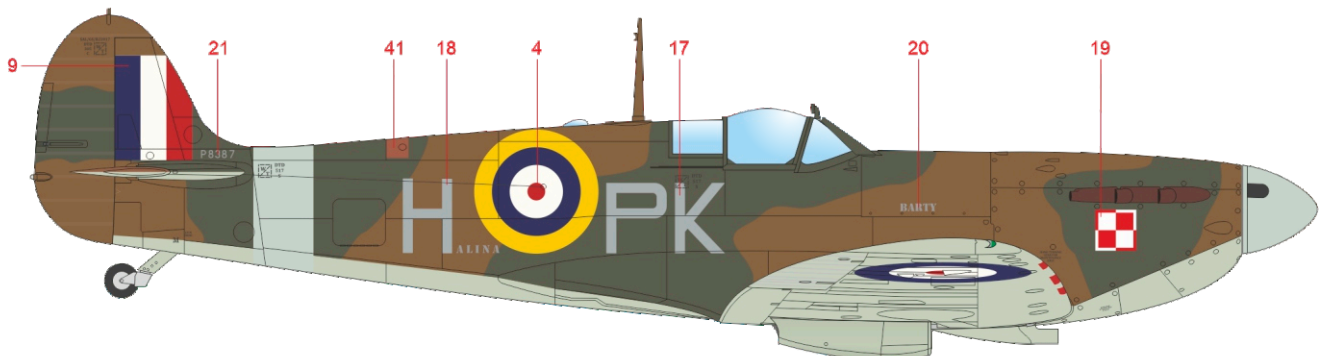

YELLOW	H4 MMP C4 007	BLACK	H12 MMP C33 047	LIGHT BLUEGREEN	H417 MMP C117 051
DARK EARTH	H72 MMP C369 078	DARK GREEN	H330 MMP C361 077	SKY	H74 MMP C368 080

**C P8038, flown by Fl/Lt. Brendan E.F. Finucane DFC, No.452 Squadron RAAF, RAF Kenley, Great Britain, August 1941**

Spitfire Mk.IIa P8038 is painted in type A camouflage, although it has an even serial number. The Rotor spinner is in Sky color. Green shamrock with the letters BF on both sides of the fuselage is the personal emblem of Irish fighter ace "Paddy" Finucane, who claimed a total of 26 individual victories. He was transferred to Australian No.452 Sqn in April 1941 after serving with No.65 Sqn. With the P8038, he claimed 4 victories and 1 probable. In January 1942 he became commander of No.602 Sqn. At the end of June he took over command of the Hornchurch Wing. He died on July 15th, 1942, in an emergency landing at sea after his plane was hit by flak. Australians Sgt. Ian Milne and Sgt. Richard Gazzard also flew the P8038 with No.452 Sqn. Spitfire was originally used by the Polish No.303 Sqn later on was also briefly used by Czechoslovaks in No.313 Sqn. After conversion to Mk.Vb version, it was used by the No.611 and Norwegian No.332 Squadron.

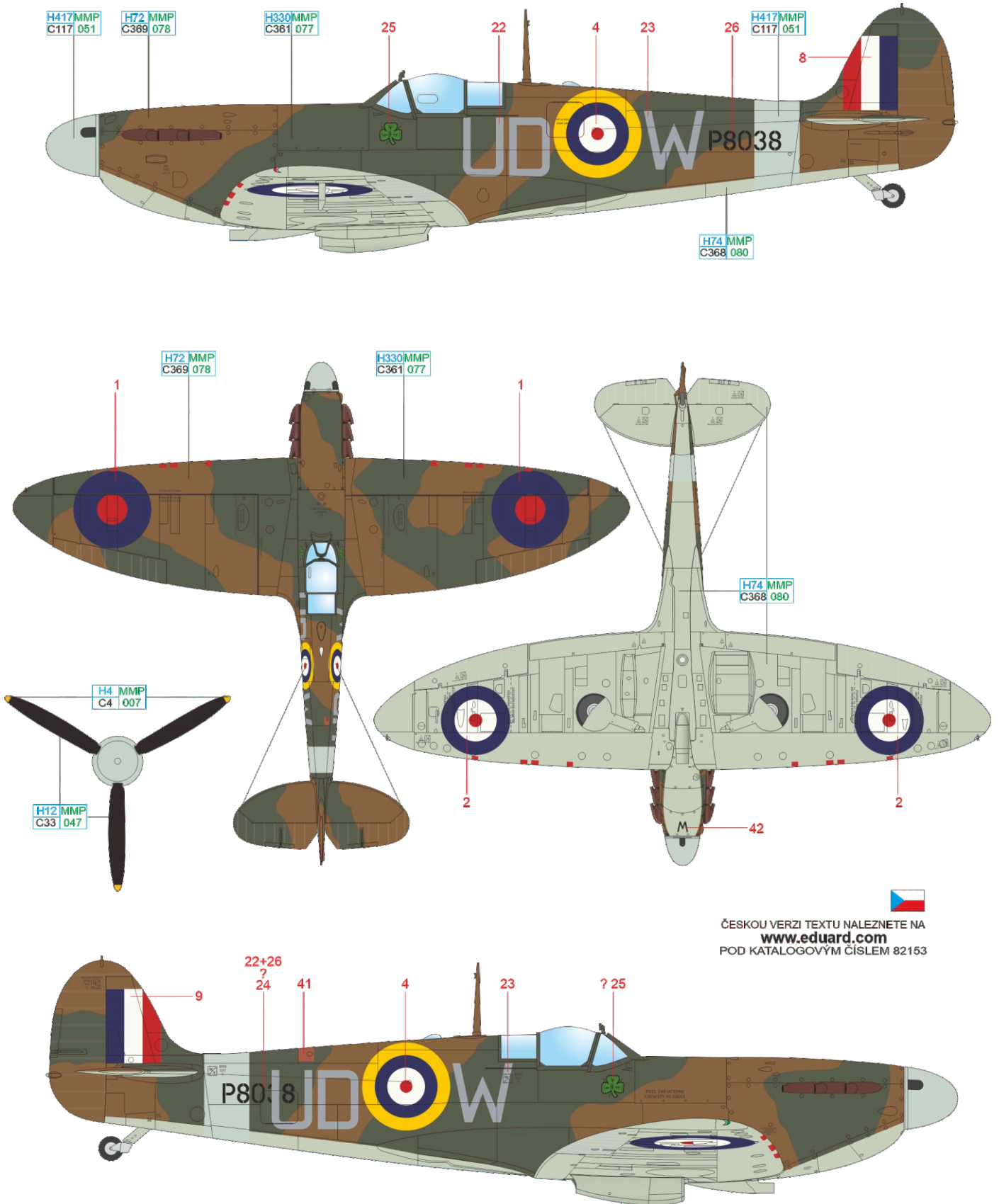

ČESKOU VERZI TEXTU NALEZNETE NA  
**www.eduard.com**  
 POD KATALOGOVÝM ČÍSLEM 82153

YELLOW	H4 MMP C4 007	BLACK	H12 MMP C33 047	LIGHT BLUEGREEN	H417 MMP C117 051
DARK EARTH	H72 MMP C369 078	DARK GREEN	H330 MMP C361 077	SKY	H74 MMP C368 080

# D P8081, flown by Fl/Lt. Tomáš Vybíral, No.312 (Czechoslovak) Squadron, RAF Ayr, Great Britain, November 1941

Spitfire Mk.IIa P8081 was painted in scheme type A. From both sides of the fuselage there is a light gray inscription GARFIELD WESTON IV. It is one of 16 aircraft funded by Willard Garfield Weston, Canadian member of the House of Commons. This philanthropist was owner of the Allied Bakeries. He also helped to create a canteen system in the London Underground during the Blitz bombing offensive. P8081 first served with the No.222 Sqn, where Sgt. Burgess used it to damage a Ju 88 in April 1941. Later on the Spitfire was assigned to Australian No.452 Sqn for about a month and from October till December it was used by Czechoslovak No.312 Sqn. A number of pilots flew with P8081, including F/Sgt Václav Šlouf. On November 17th, it was damaged by F/Lt. Tomáš Vybíral after landing in poor visibility. This pilot scored 7 victories in the French Air Force and achieved the rank of Wing Commander in the RAF. After the war he emigrated from Czechoslovakia and joined the anti-communist resistance.

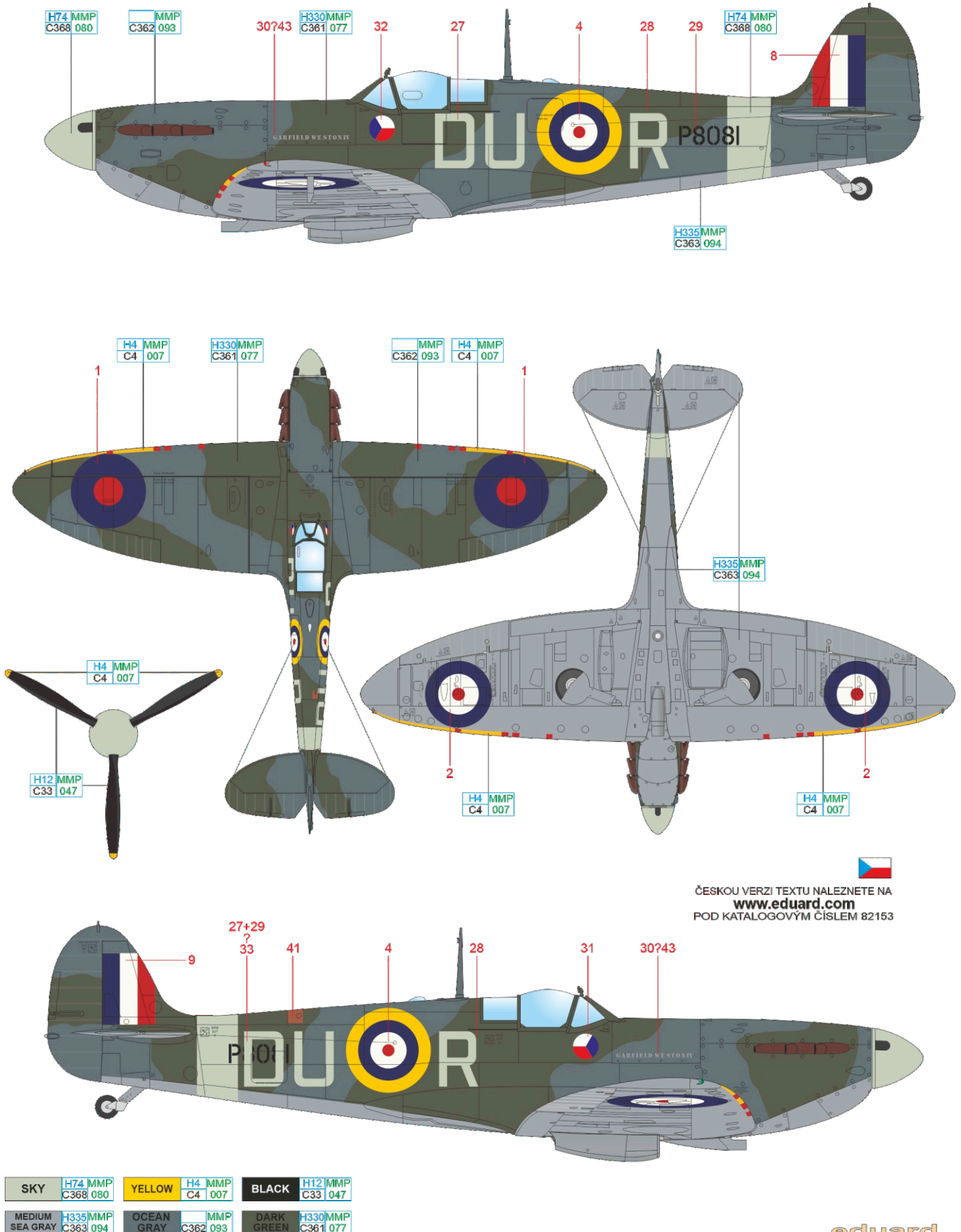

ČESKOU VERZI TEXTU NALEZNETE NA  
[www.eduard.com](http://www.eduard.com)  
 POD KATALOGOVÝM ČÍSLEM 82153

SKY	H74 MMP C368 080	YELLOW	H4 MMP C4 007	BLACK	H12 MMP C33 047
MEDIUM SEA GRAY	H335 MMP C363 094	OCEAN GRAY	MMP C362 093	DARK GREEN	H330 MMP C361 077

# E P7840, No.340 (Free French) Squadron, RAF Ayr, Great Britain, January 1942

Spitfire Mk.IIa P7840 is painted in scheme type B. Rotol spinner is in Sky color. On both sides of the bow is a blue or dull red Lorraine cross in a white shield. Below the canopy is a light grey inscription related to aircraft funding. Belfast Telegraph founded in North Ireland the Spitfire Fund during the Battle of Britain, where its readers raised enough funds to buy 17 Spitfires. A total of 12 of their airmen were killed in combat. The P7840 was the 13th machine of the Fund. The upper part of the inscription refers to the song of the same name by the Irish composer Percy French. This Spitfire served with the No.64 Sqn from February 1941 and was taken over in December by No.340 Sqn. Free French used it until February 1942, when they switched to Spitfires Mk.V. This unit conducted 7,845 combat flights, shot down 37 aircraft and destroyed more than 500 ground targets. A total of 30 of pilots were killed and six were captured. After the war, unit received the Ordre de la Libération.

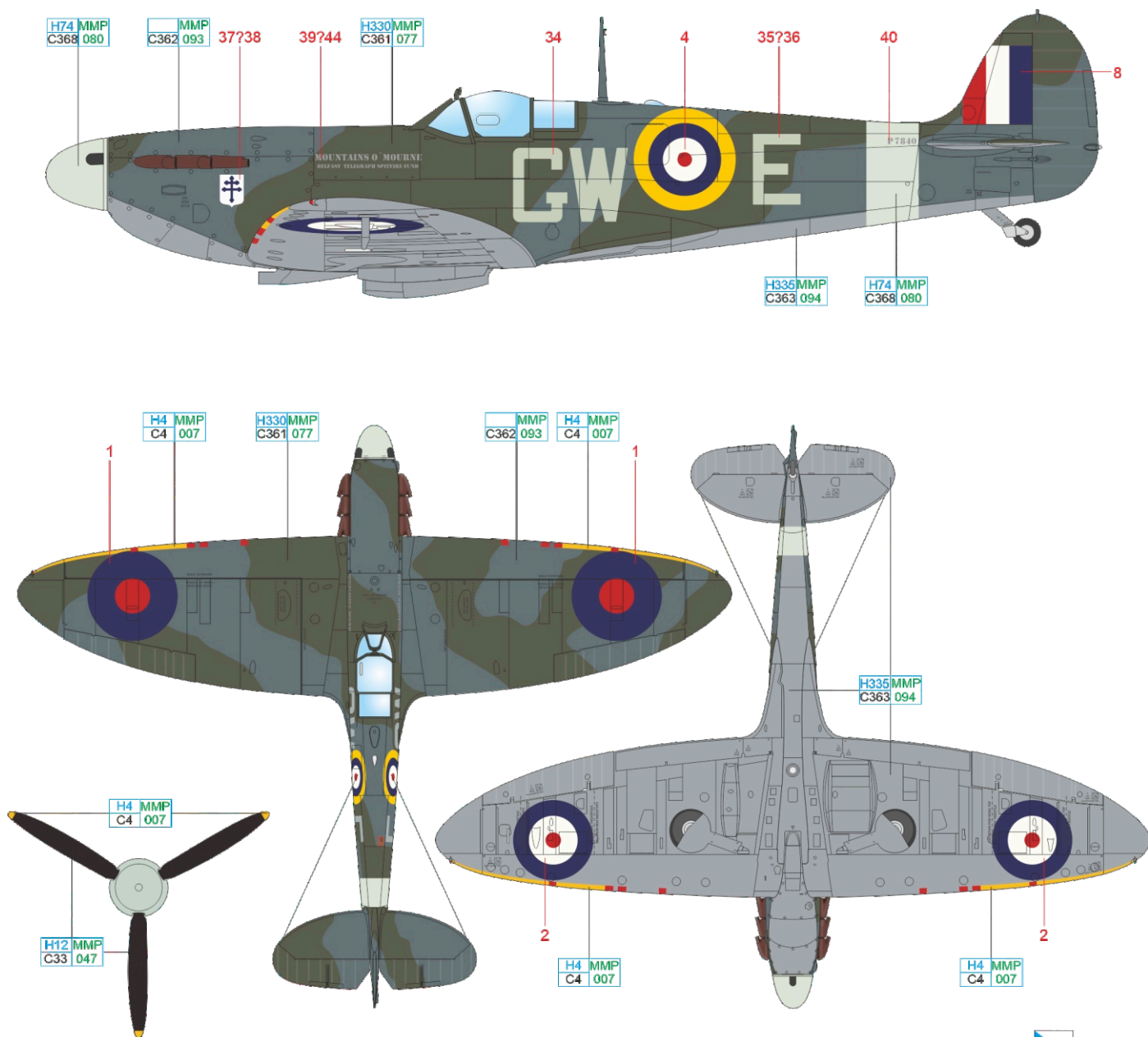

ČESKOU VERZI TEXTU NALEZNETE NA  
[www.eduard.com](http://www.eduard.com)  
 POD KATALOGOVÝM ČÍSLEM 82153

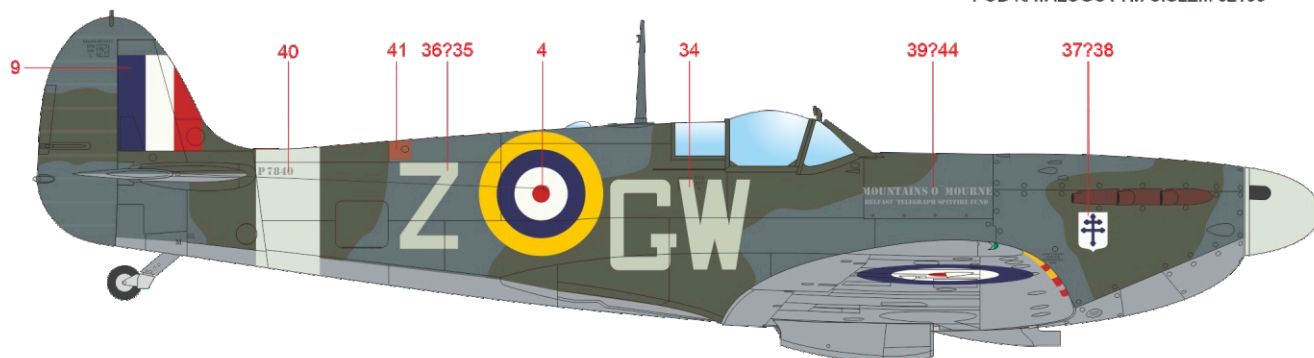

SKY	H74 MMP C368 080	YELLOW	H4 MMP C4 007	BLACK	H12 MMP C33 047
MEDIUM SEA GRAY	H335 MMP C363 094	OCEAN GRAY	MMP C362 093	DARK GREEN	H330 MMP C361 077

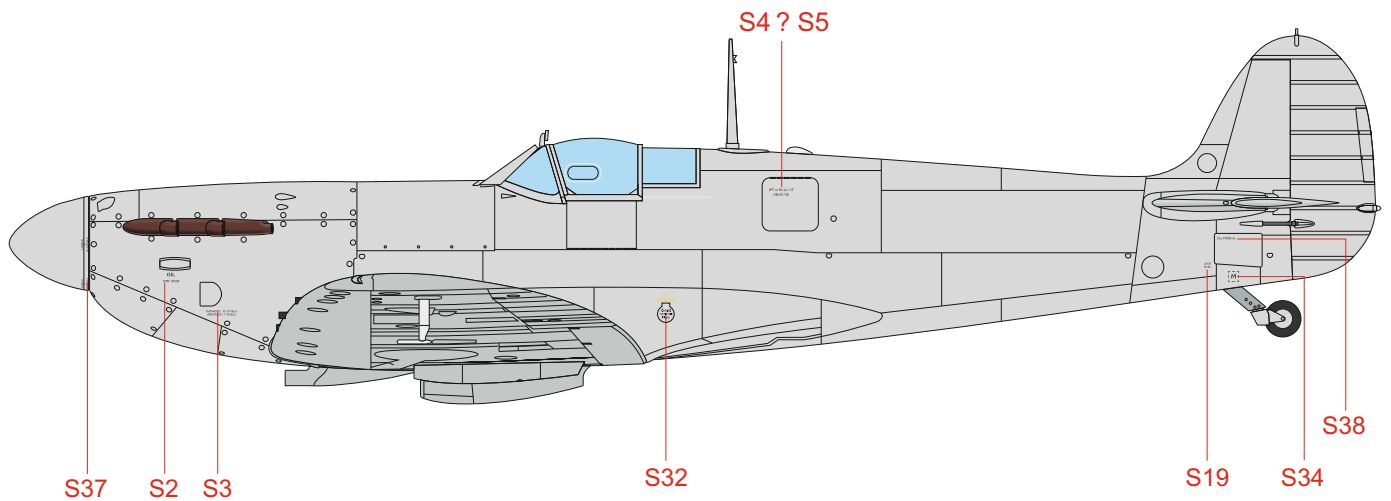
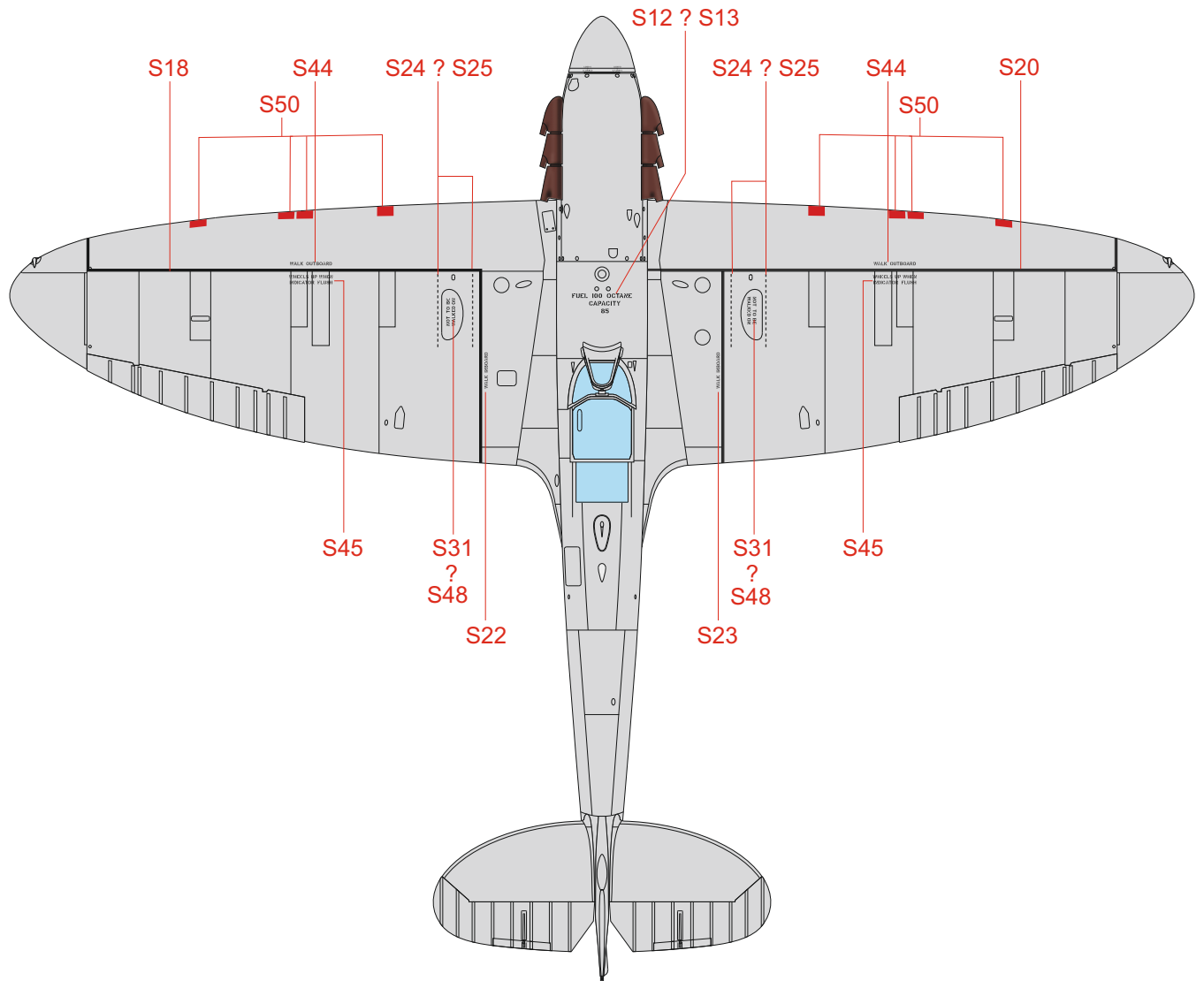

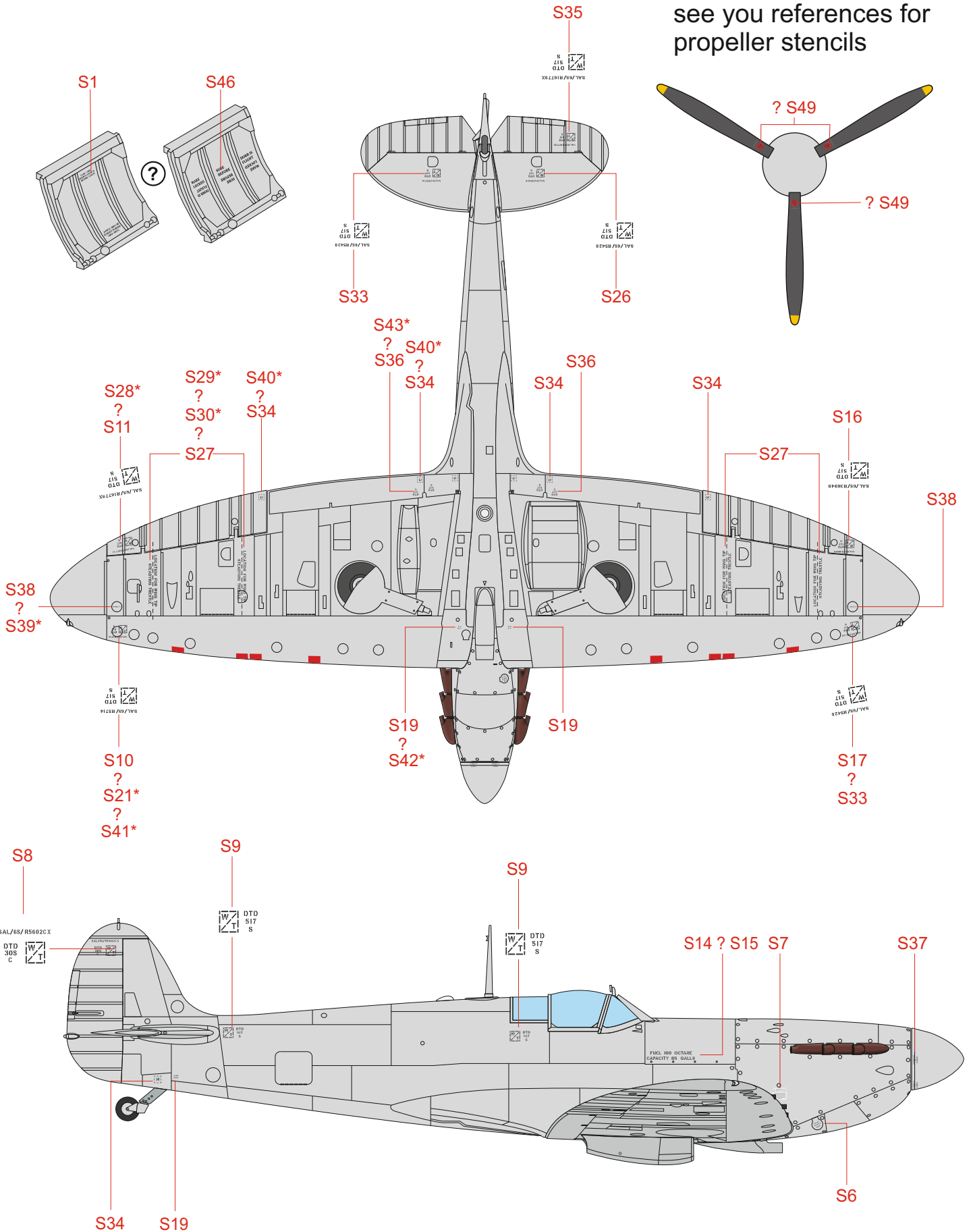

\*White stencils for the black painted wing only.