

Spitfire Mk.IIb

eduard

1/48 Scale Plastic Model Kit

ProfiPACK
edition

The Supermarine Spitfire is so iconic airplane, that virtually everyone can recognize it. The service of this elegant fighter spanned remarkable 13 years. It entered the service at the end of biplane era and remained in the frontline use until the jet age.

By the early 30s the RAF was looking for replacement of its ageing Hawker Fury biplane fighters. The need of considerably faster aircraft was obvious, as the racing monoplane floatplanes of that time were reaching about twice the speed of the Fury. One of the most successful designers of the racing floatplanes was Reginald J. Mitchell. His Supermarine S.6B raised the world speed record to 407 mph (655 km/h) on September 20, 1931 and British Air Ministry, under influence of such achievement, issued the specification F.7/30 in October 1931. Although it called for pursuit airplane capable of at least 250 mph (400 km/h), seven out of eight entries were biplanes. The only monoplane proposal was Mitchell's Supermarine 224, but the design with a gull wing, fixed undercarriage and Rolls-Royce Goshawk engine was a disappointment because of the lack of speed and poor rate of climb. After that the RAF chose the Gloster Gladiator biplane as the winner.

From disillusion to success

The fiasco with Type 224 did not prevent Mitchell from further work. He had already numerous changes in mind, but later persuaded the Supermarine company to fund the work on completely new design Type 300 using brand new Rolls-Royce PV12 engine, later known as the Merlin. The Air Ministry expressed interest and issued specification F.37/34 on December 28, 1934 to fund the prototype armed with four wing mounted guns. But by early April 1935 Mitchell received the detail of specification F10/35, calling for eight guns. The change was made on cost of bomb provision removal and reduction of the capacity of the fuel tanks to sixty-six gallons. The decision caused lack of range and endurance of the Spitfire.

The Supermarine Type 300 made its maiden flight on March 5, 1936. The K5054 prototype took off from the Eastleigh Aerodrome with chief test pilot Captain Joseph "Mutt" Summers on controls. After only some eight minutes of the flight the pilot was so impressed, he reportedly said: "Do not change a thing!".

Initial contract to produce 310 Spitfires was signed in June 1936 and the first unit receiving the new fighters was No. 19 Squadron at Duxford during August 1938. At the time the Great Britain entered the war with Germany (September 3, 1939), the RAF had already taken delivery of 306 Spitfires serving with eleven squadrons. By the beginning of May 1940, a further eight squadrons received Spitfires. Unfortunately, Reginald Mitchell did not live to see the Spitfire serving with the RAF units, as he died on June 11, 1937 at the age of 42. The burden of the Spitfire development was on Joe Smith afterwards.

The first dogfight between Messerschmitt Bf 109s and Spitfire Mk.II took place near Calais on May 23, 1939, but the first aerial victory over an enemy for Spitfire had to wait until October 16, 1939, when nine Junkers Ju 88s attacked Royal Navy warships in the Firth of Forth. Two of them were shot down. The German forces launched their offensive in the West Europe half a year later and the Spitfires started to fire their guns in anger much more frequently.



item No. 82154

Propellers and engines

The development of Spitfire was ongoing process from very early stage of its service. One of the first major upgrades was change from ineffective two blade fixed-pitch wooden propeller to three-bladed two-pitch metal one starting from 78th production aircraft (and retrofitted to the earlier ones). The move increased the maximum speed, raised the ceiling, and shortened the take-off run. Starting from May 1939 the Spitfire Mk.IIs changed the power unit, switching from Rolls-Royce Merlin II to Merlin III with the same power 1030 hp (768 kW) but with reliability improvements, allowing the installation of constant speed wide-bladed Rotol propeller. That not only gave the Spitfire, now marked Mk.Ia, substantial improvement in rate of climb, but also made it easier to control.

Arming and arming the Spitfire

The early production Spitfires had no armour protection. As a first measure the laminated glass was added to the windscreen. After that, the upper fuel tank received 3mm thick cover of light alloy, while lower one was protected by the Linatex sandwich (rubber and canvas) and more to it, the steel plate was fitted behind the seat to protect pilot. All that armour added weight, but despite the loss of some speed as a result the later aircraft were better fighters than the early ones.

The armament consisted of eight 0.303 in (7,7 mm) Browning guns. It was believed to be the best arrangement during mid-30s, but the early war experience proved it inadequate against multi engine bombers with self-sealing fuel tanks. The RAF tried to change for heavier weapons, choosing the French 20mm Hispano-Suiza Type 404 cannons, but the wing installation in Spitfire proved to be troublesome. A small batch of Mk.IIs entered the service with No. 19 Squadron as the Mk.IIb in June 1940, but the cannons proved unreliable. The problems were solved at the end of 1940, paving the way for heavier armament of the later marks.

The kit: Spitfire Mk.IIb

The Mk. II was another substantial improvement in the Spitfire development thanks to the more powerful Merlin XII engine rated at 1150 hp (857 kW). The engine also used 100 octanes fuel instead of 87 octanes. Meantime Spitfires Mk.I of Nos. 54 and 66 Squadron were fitted with the new propeller Rotol RX 5/1 during early 1940, recognizable clearly by the bigger and more rounded spinner. It became standard with Spitfire Mk. II (some received the Rotol RX 5/3 ones with wooden blades instead). The Mk.II was also fitted with pyrotechnical starter Coffman. To fit it under the engine cowling, a small bulge had to be added to the right-side engine cowling. The Spitfire Mk.II retained the armament of the Mk.I, while Mk.IIb had the same weaponry as the Mk.Ib, i.e. four cannons Hispano-Suiza of the 20mm calibre. There were 921 Spitfires of Mk.II variant produced, all manufactured at Castle Bromwich factory.

ATTENTION



UPOZORNĚNÍ



ACHTUNG



ATTENTION



注意



Carefully read instruction sheet before assembling. When you use glue or paint, do not use near open flame and use in well ventilated room. Keep out of reach of small children. Children must not be allowed to suck any part, or pull vinyl bag over the head.



Před započítím stavby si pečlivě prostudujte stavební návod. Při používání barev a lepidel pracujte v dobře větrané místnosti. Lepidla ani barvy nepoužívejte v blízkosti otevřeného ohně. Model není určen malým dětem, mohlo by dojít k požití drobných dílů.

INSTRUCTION SIGNS * INSTR. SYMBOLS * INSTRUKTION SINNBILDEN * SYMBOLES * 記号の説明

OPTIONAL
VOLBABEND
OHNOUTSAND
BROUSITOPEN HOLE
VYVRTAT OTVORSYMETRICAL ASSEMBLY
SYMETRICKÁ MONTÁŽREMOVE
ODŘÍZNOUTREVERSE SIDE
OTOČITAPPLY EDUARD MASK
AND PAINT
POUŽIT EDUARD MASK
NABARVIT

PARTS



DÍLY



TEILE



PIÈCES



部品

PLASTIC PARTS

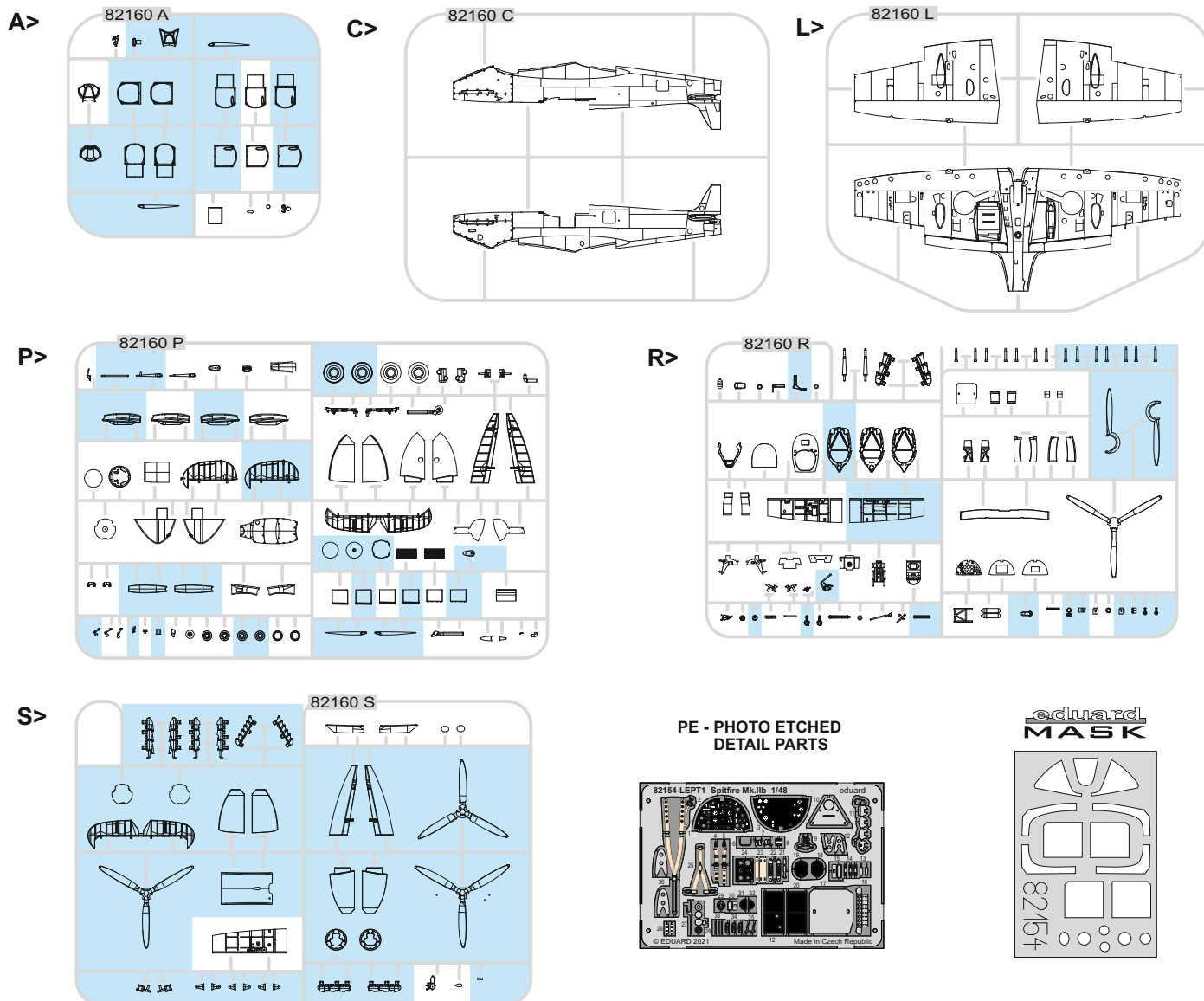

-Parts not for use. -Teile werden nicht verwendet. -Pièces à ne pas utiliser. -Tyto díly nepoužívejte při stavbě. - 使用しない部品

COLOURS



BARVY



FARBEN



PEINTURE



色

GSI Creos (GUNZE)		MISSION MODELS	
AQUEOUS	Mr.COLOR	PAINTS	
H3	C3	MMP-003	RED
H4	C4	MMP-007	YELLOW
H8	C8		SILVER
H12	C33	MMP-047	FLAT BLACK
H33	C81		RUSSET
H51	C11	MMP-063	LIGHT GULL GRAY
H72	C369	MMP-078	DARK EARTH
H74	C368	MMP-080	SKY
H77	C137	MMP-040	TIRE BLACK
H90	C47		CLEAR RED
H94	C138		CLEAR GREEN

GSI Creos (GUNZE)		MISSION MODELS	
AQUEOUS	Mr.COLOR	PAINTS	
H330	C361	MMP-077	DARK GREEN
H335	C363	MMP-094	MEDIUM SEAGRAY
H417	C117	MMP-051	LIGHT BLUE
	C362	MMP-093	OCEAN GRAY
	C364	MMP-079	AIRCRAFT GRAY-GREEN
Mr.METAL COLOR		METALLICS	
	MC214	MMM-001	DARK IRON
	MC218	MMM-003	ALUMINIUM
Mr.COLOR SUPER METALLIC		METALLICS	
	SM201	MMC-001	SUPER FINE SILVER

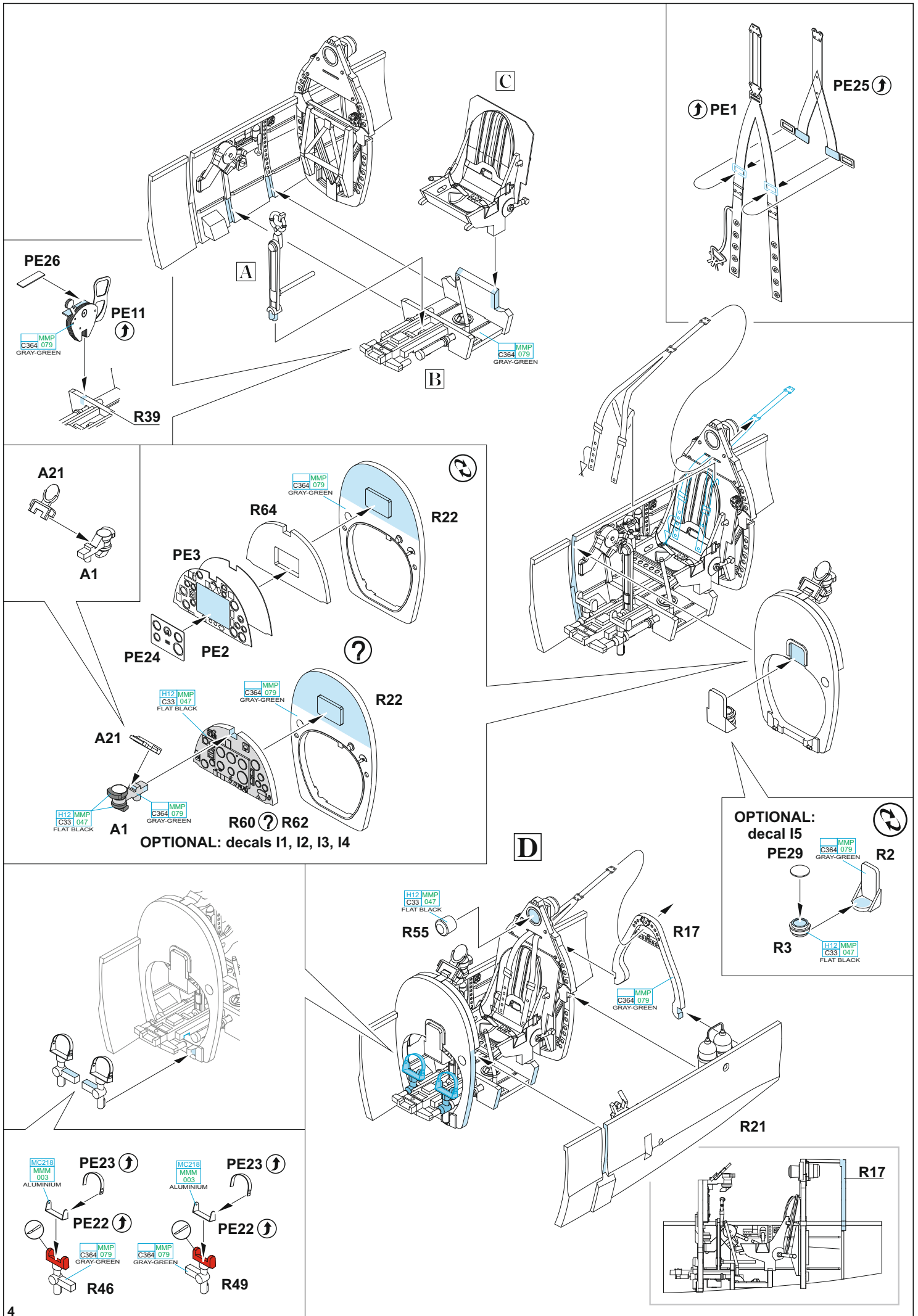

7 FOR CLOSED CANOPY ONLY

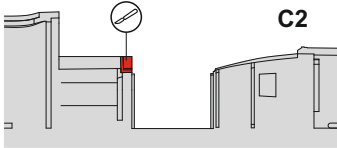

C2

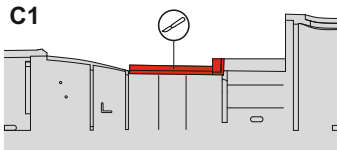

C1

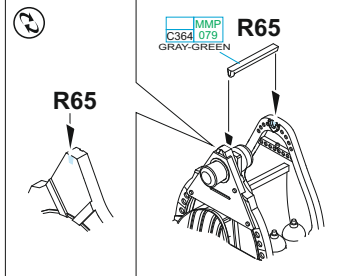

R65

MMP C364 079 GRAY-GREEN

R65

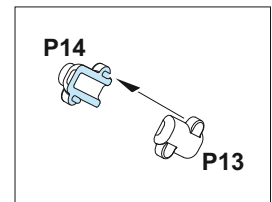

P14

P13

MC218 MMM 003 ALUMINIUM

MMP C364 079 GRAY-GREEN

H12 MMP C33 047 FLAT BLACK

P45

C1

R1

D

R20

E

C2

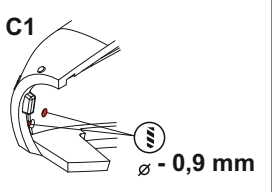

C1

P22

∅ - 0,9 mm

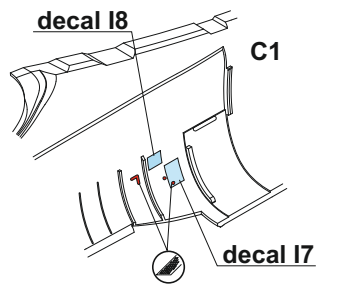

decal I8

C1

decal I7

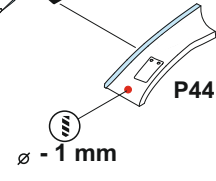

P44

∅ - 1 mm

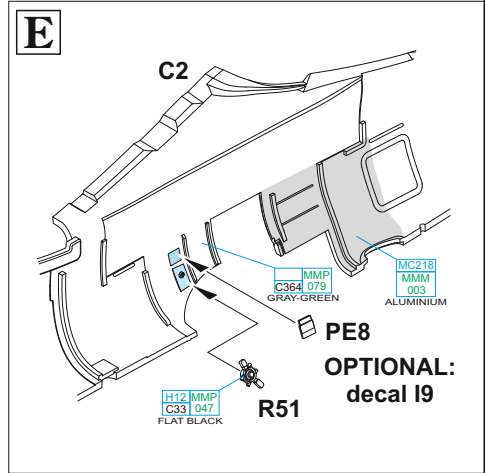

E

C2

MMP C364 079 GRAY-GREEN

MC218 MMM 003 ALUMINIUM

PE8
OPTIONAL:
decal I9

H12 MMP C33 047 FLAT BLACK

R51

∅ - 0,9 mm

H8 C8 SILVER

R29

L3

∅ - 0,9 mm

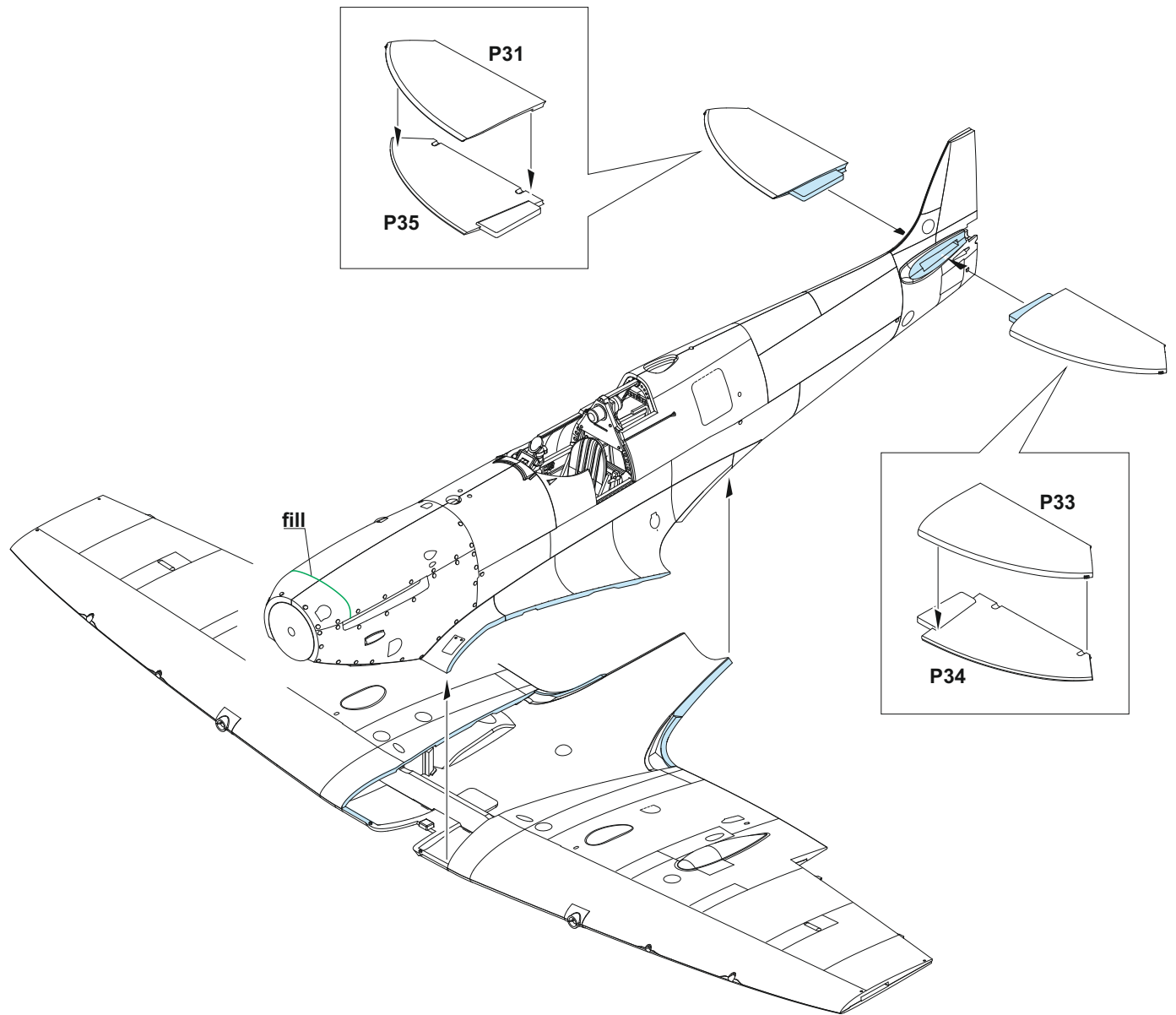

**GLUE PARTS P40 & P41
ONE BY ONE**

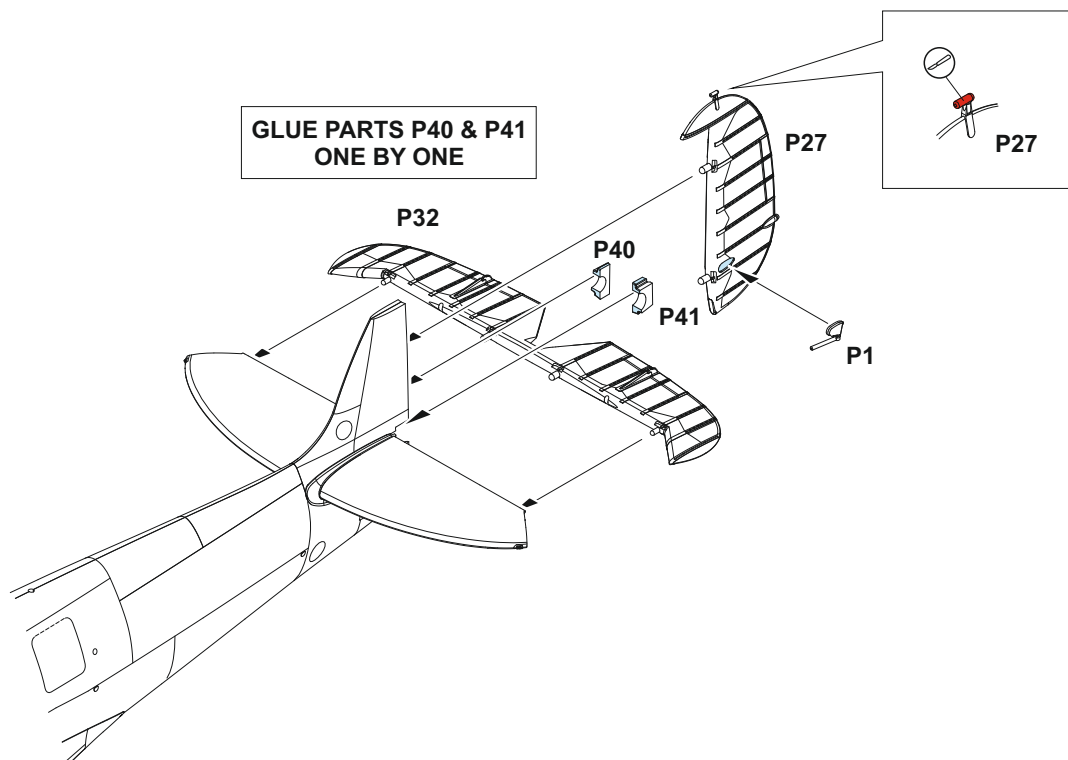

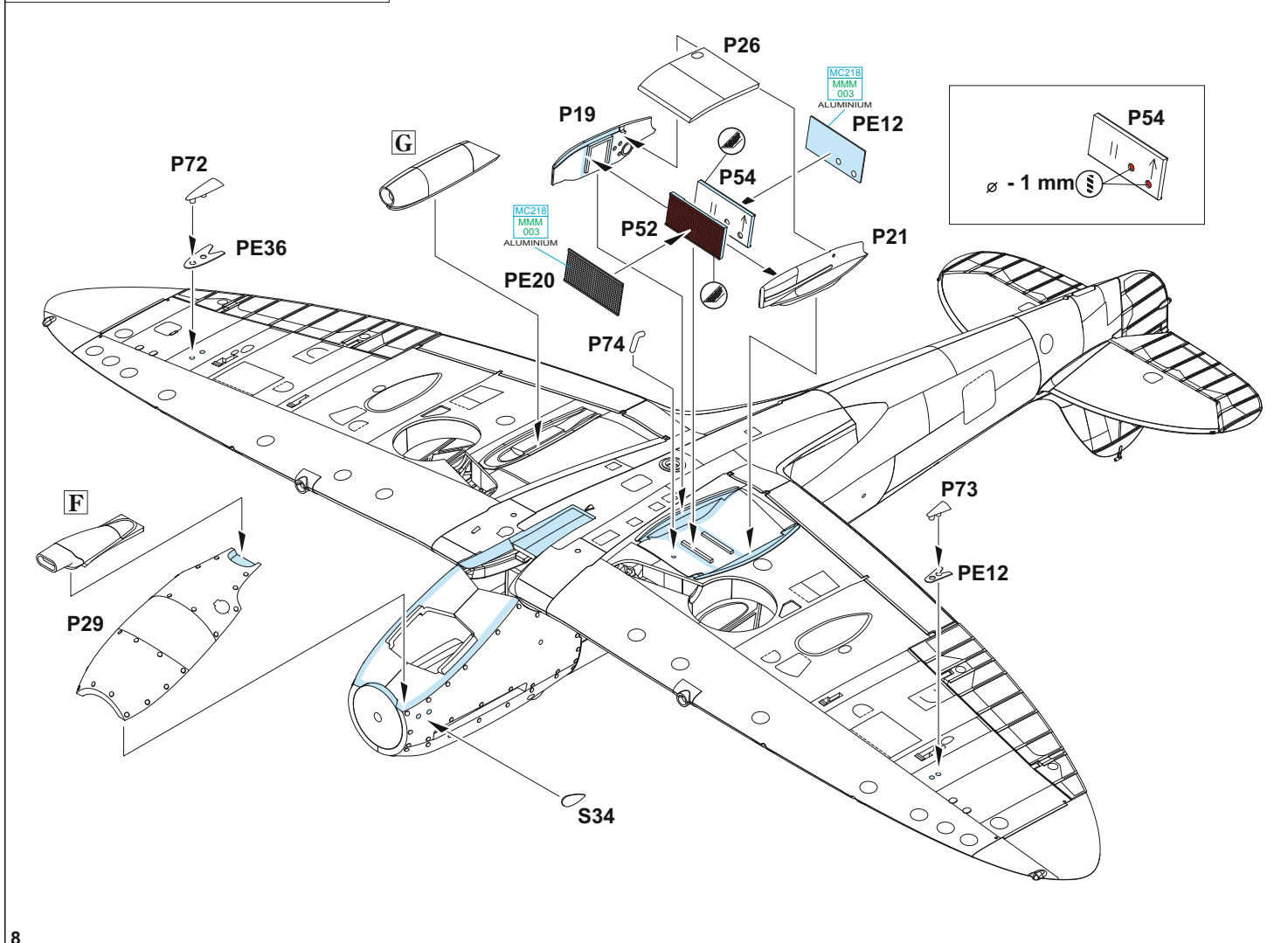
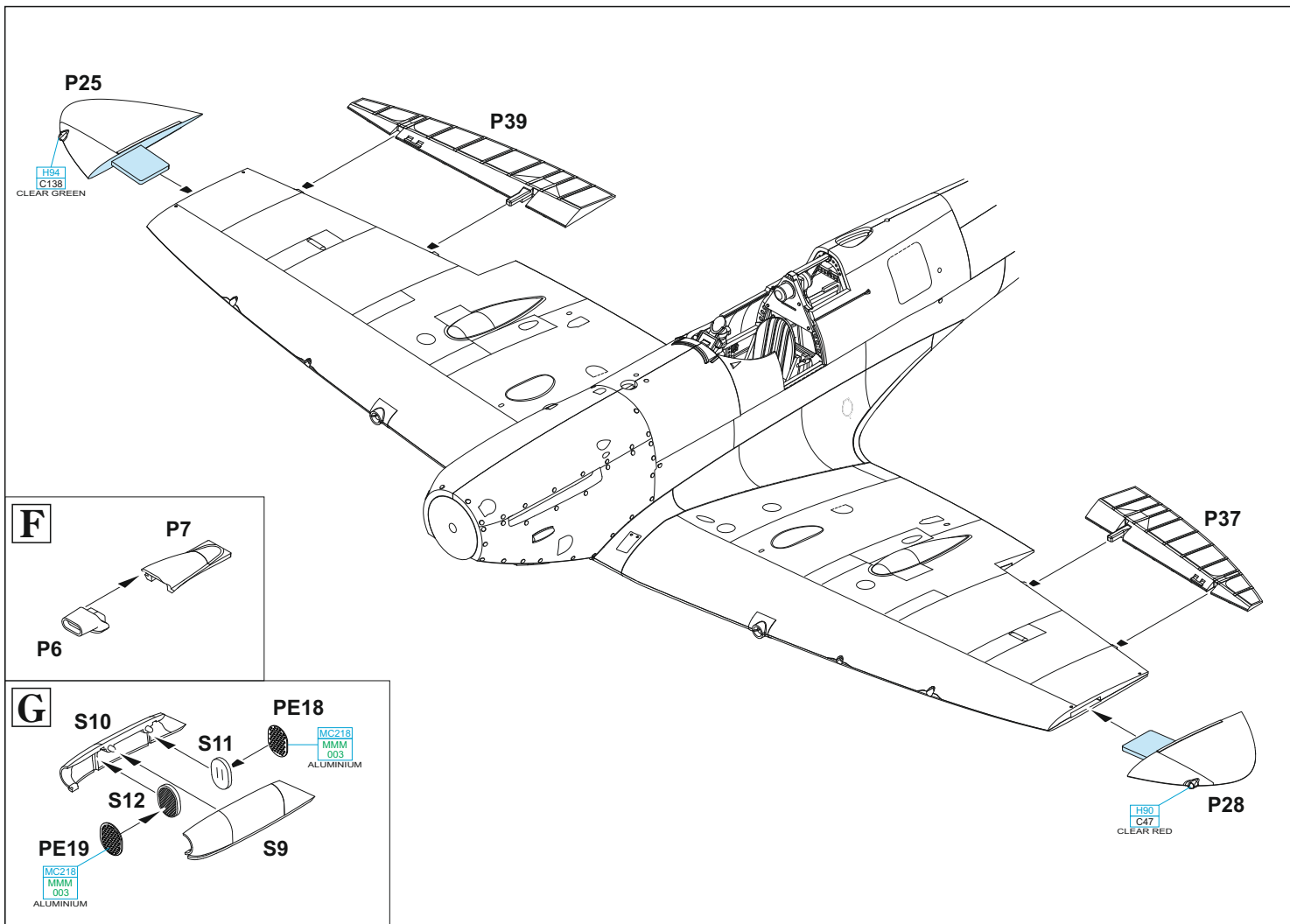

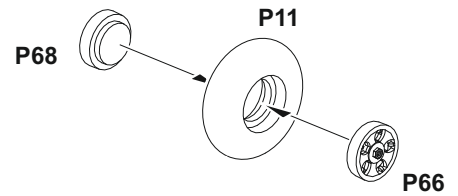
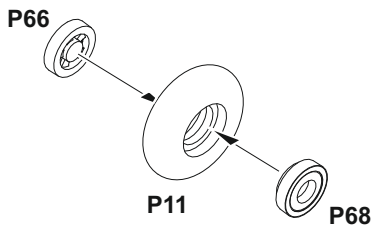
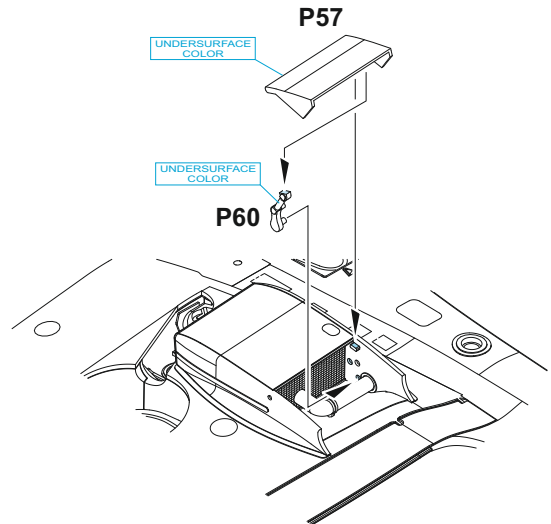
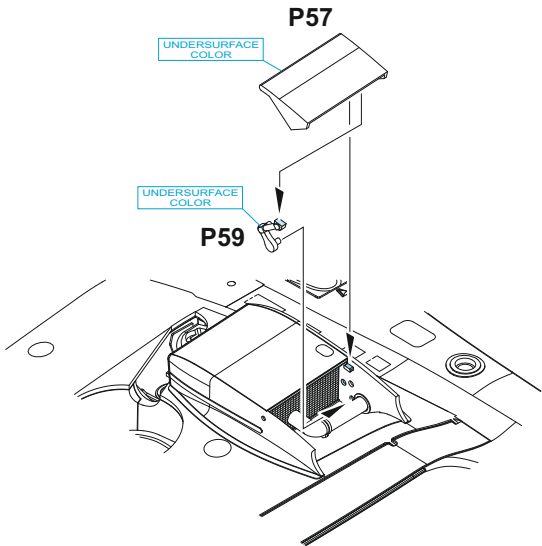
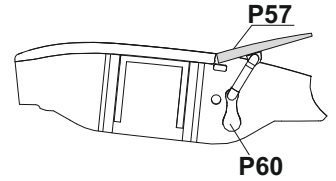
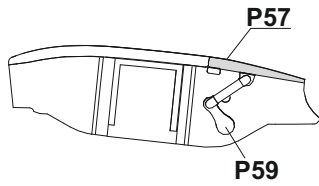
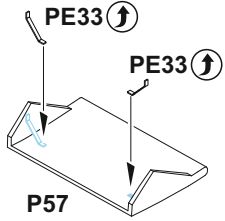
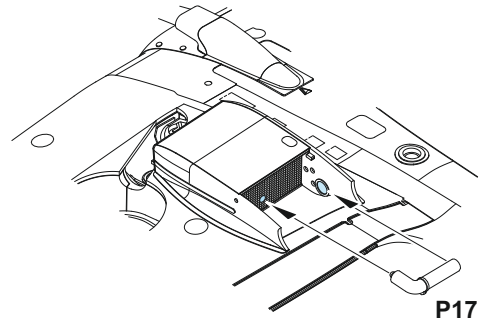
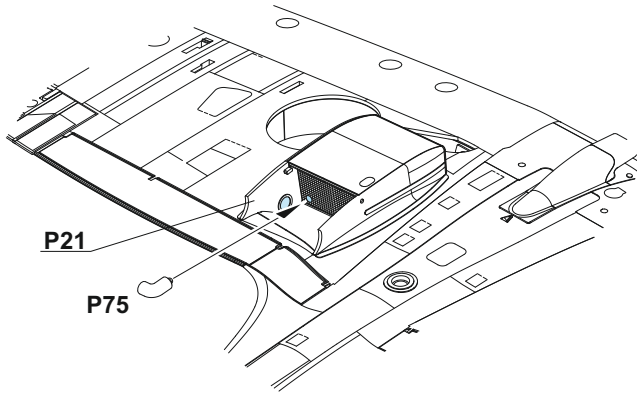

H

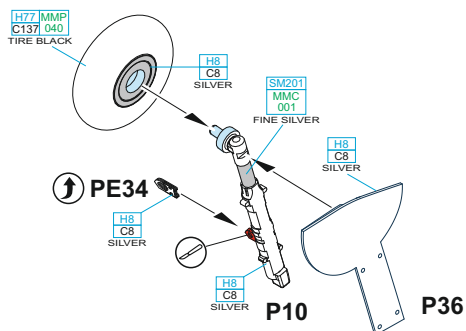

I

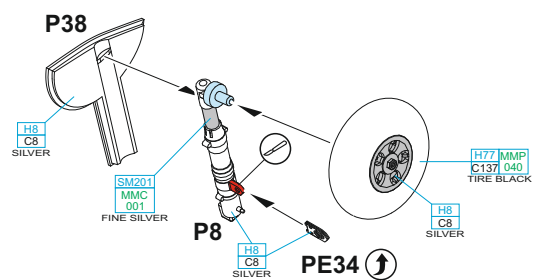

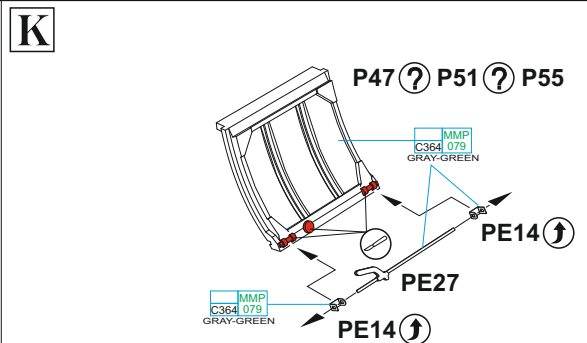
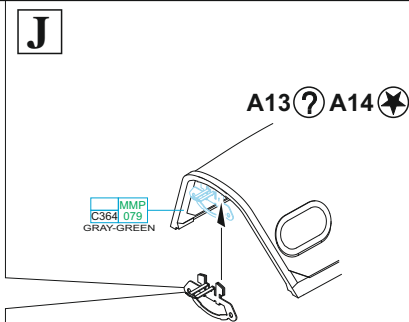
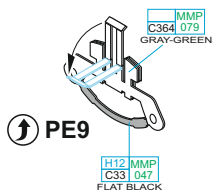
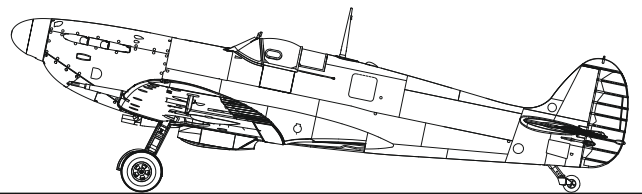
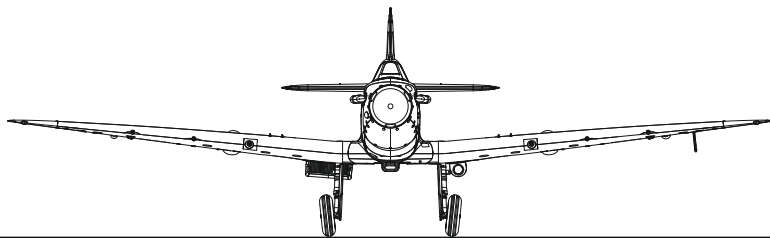
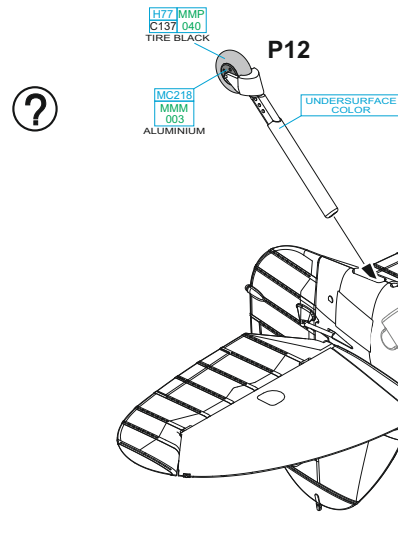
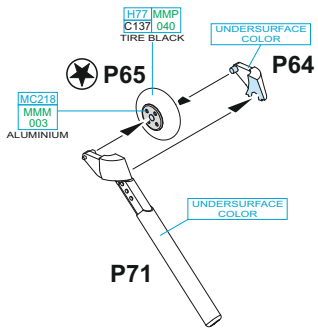
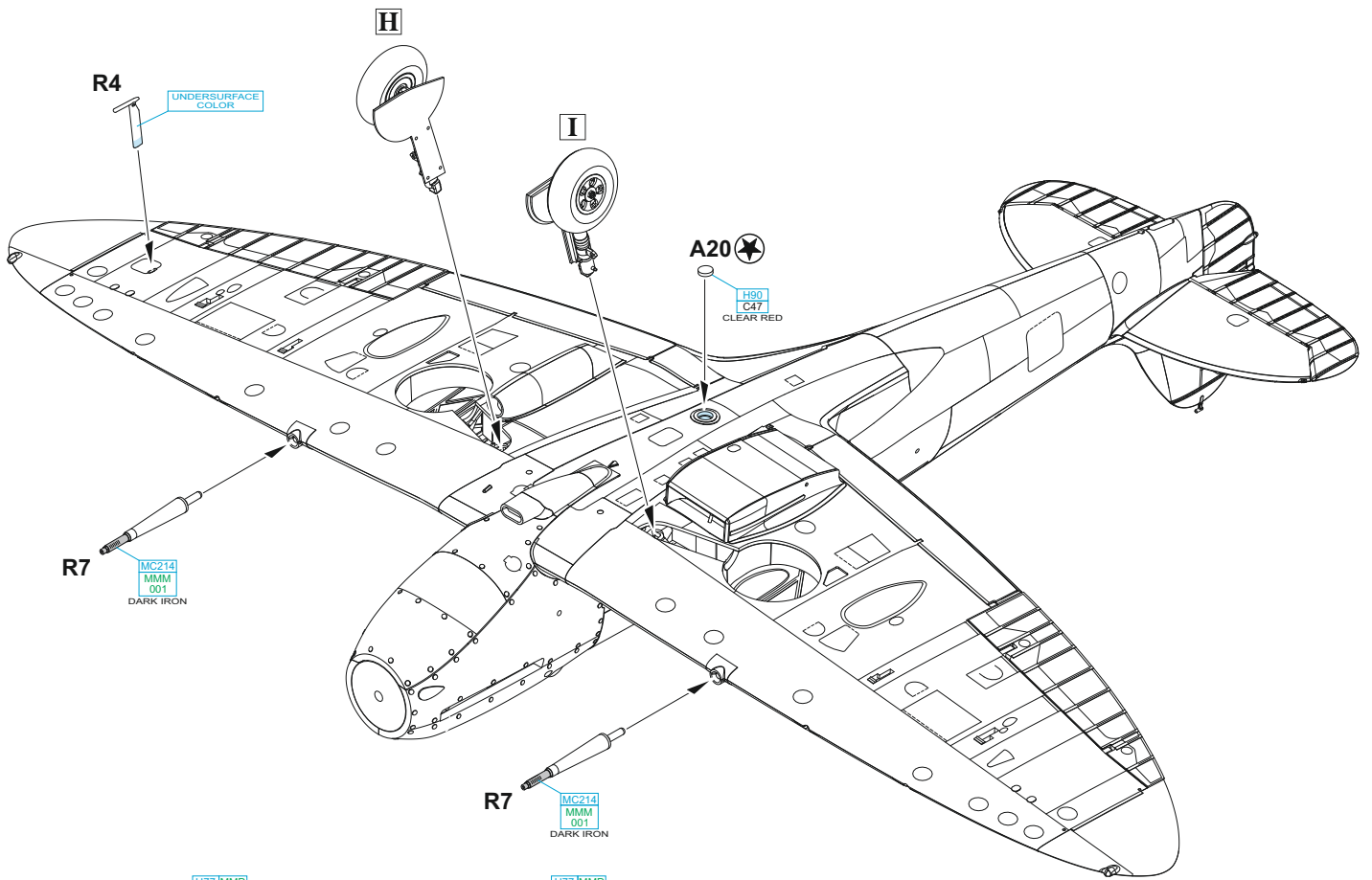

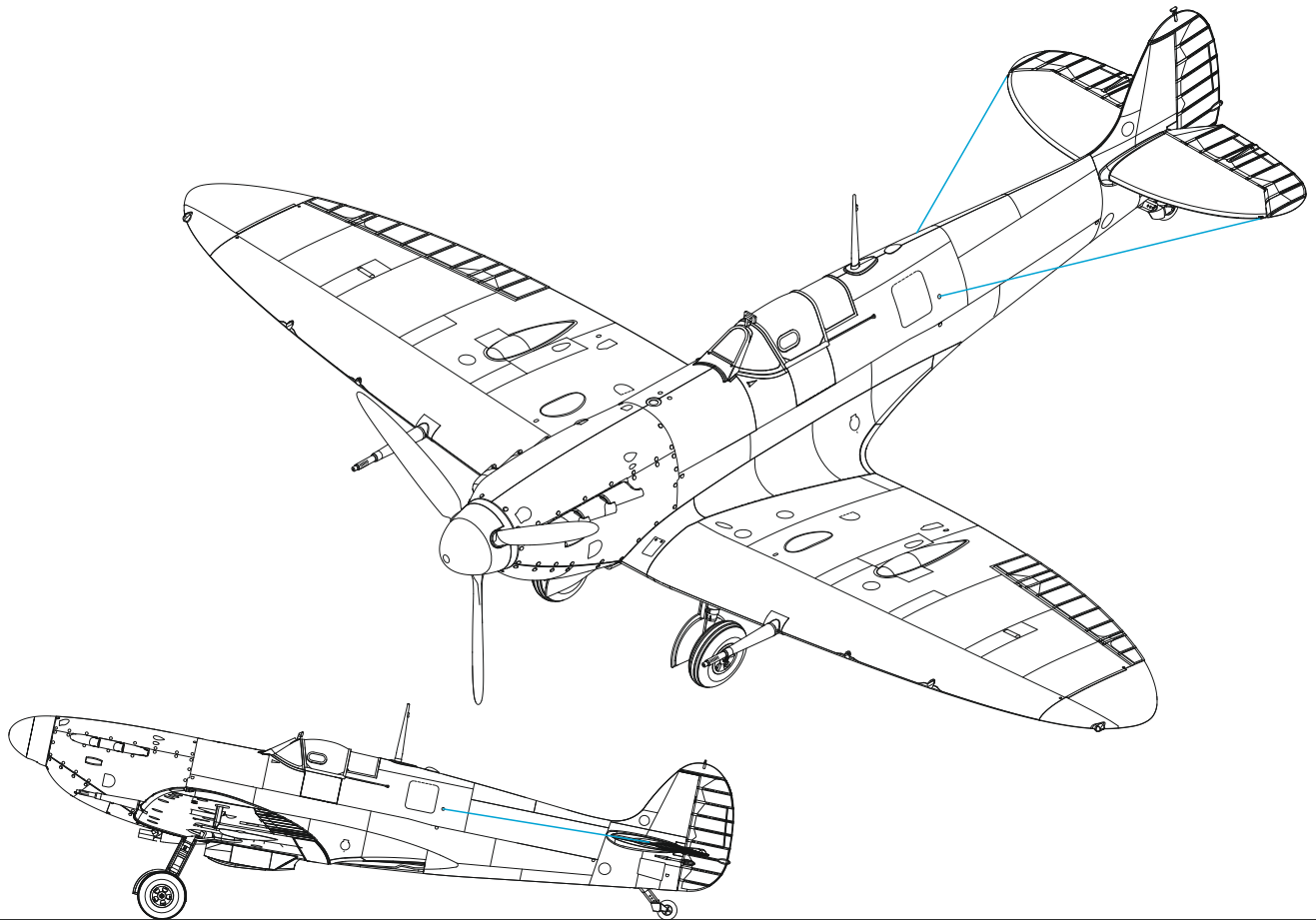

Spitfire Mk.IIb

STENCILING POSITIONS

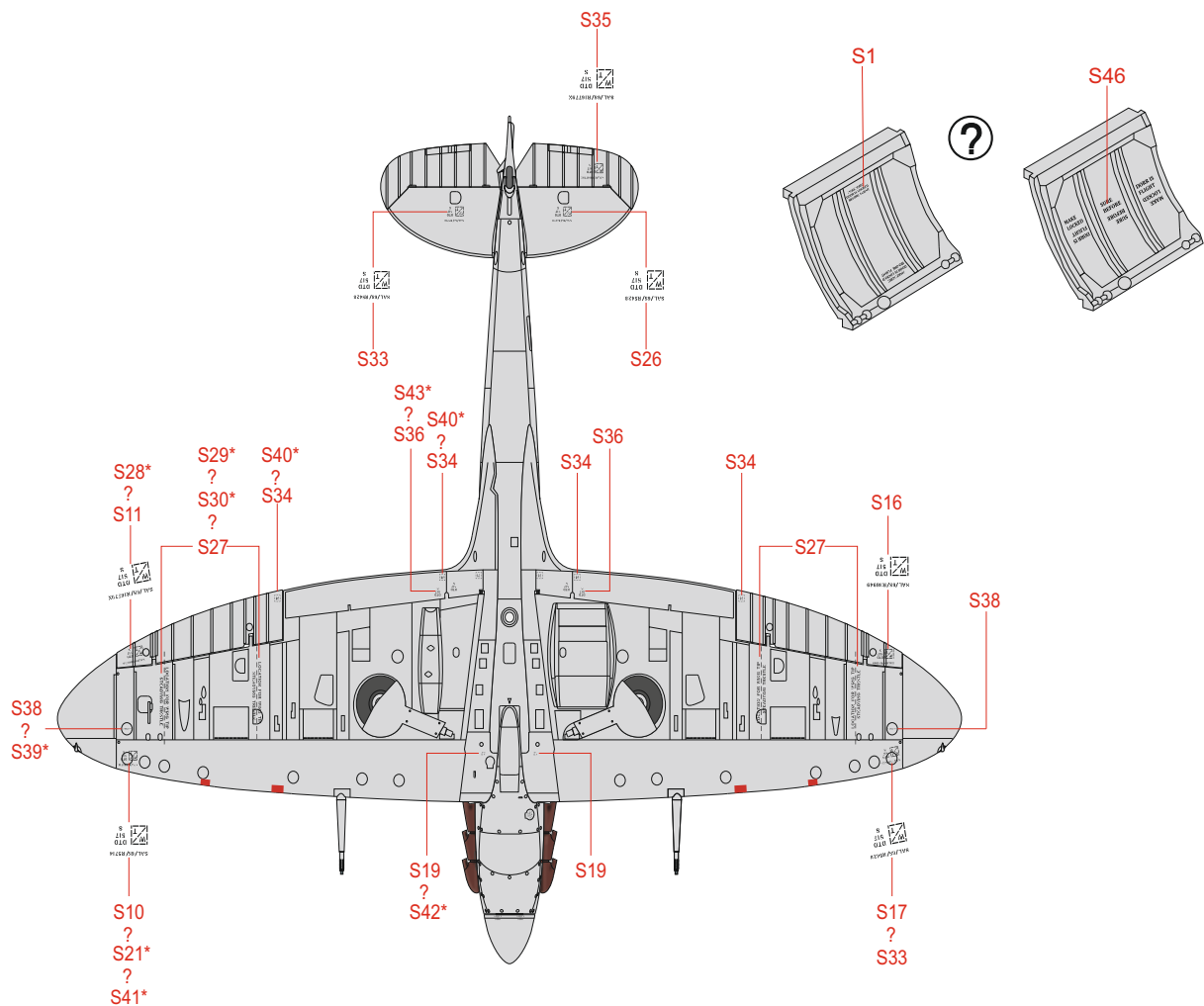

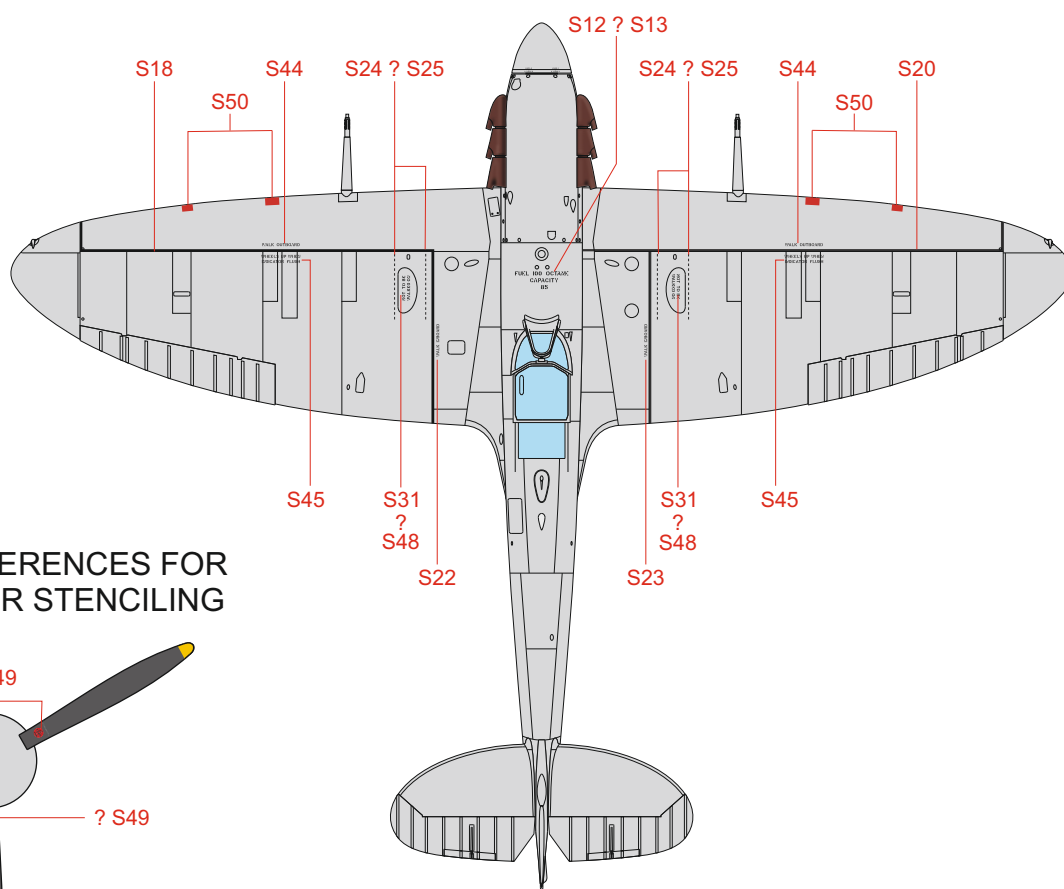
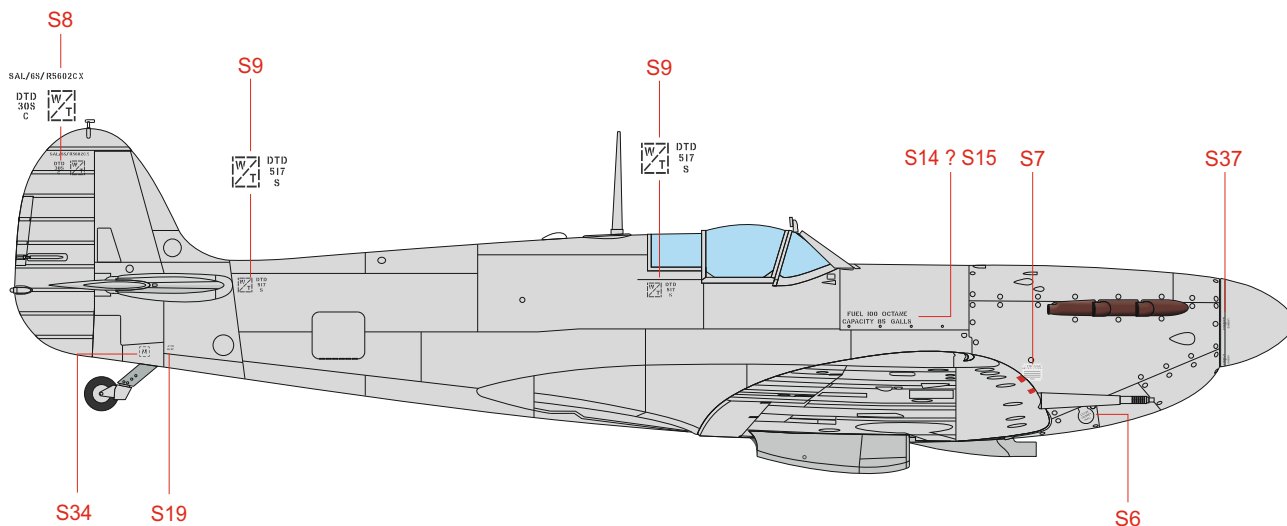

SEE YOUR REFERENCES FOR THE PROPELLER STENCILING

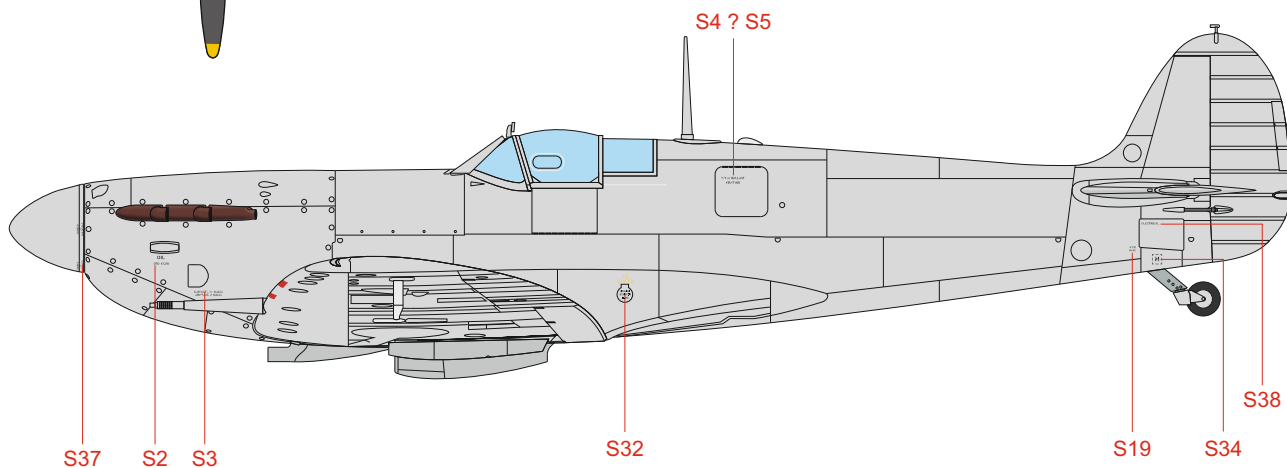
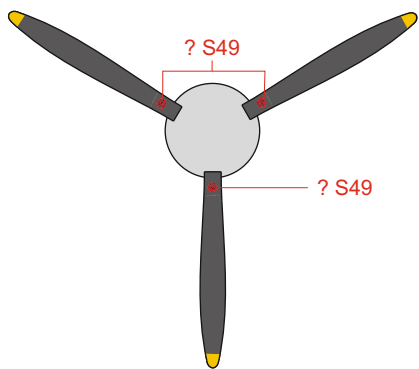

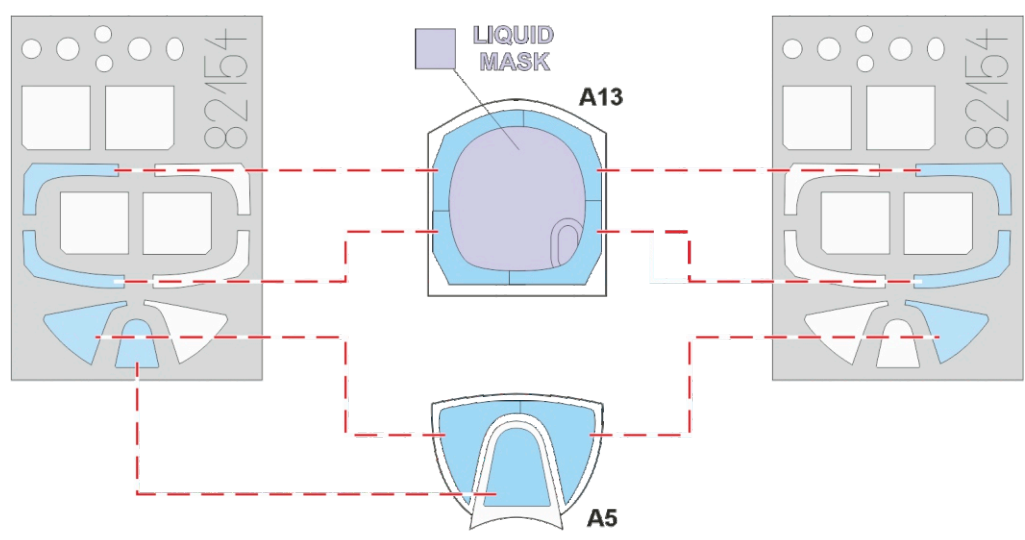
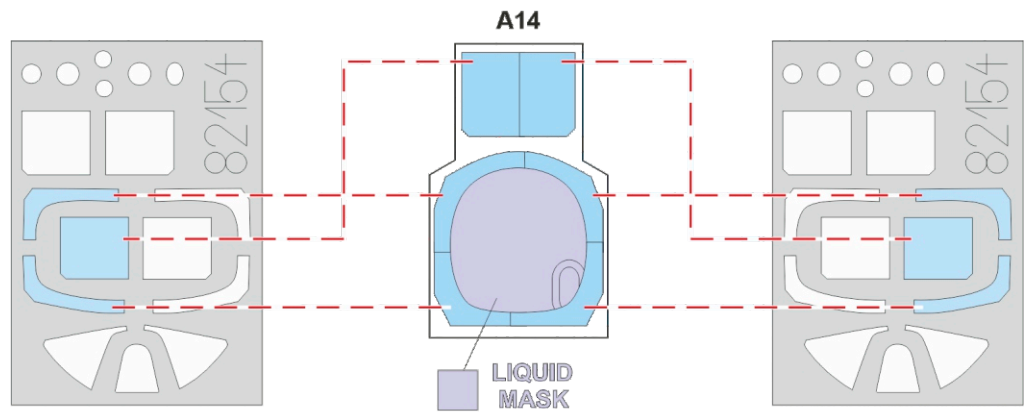
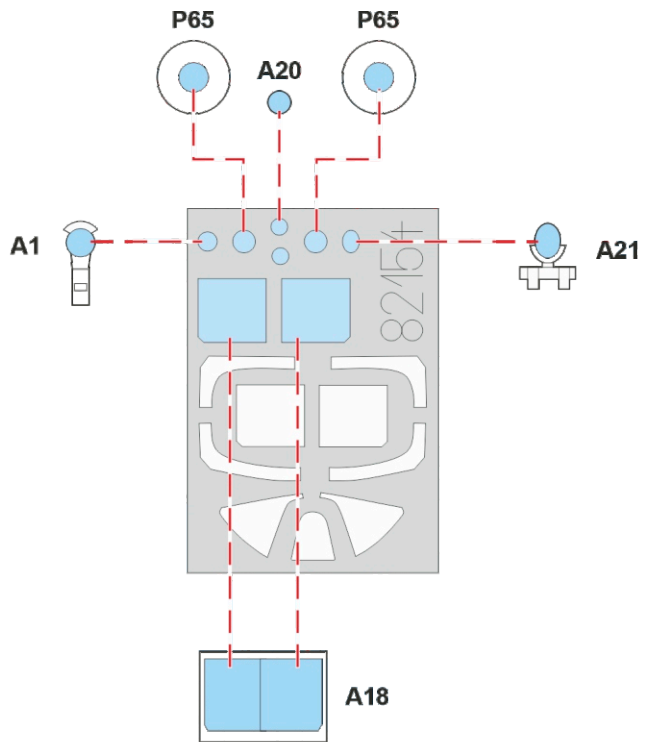

A P/O Frederick A. O. Gaze, No. 610 (County of Chester) Squadron, RAF Westhampnett, West Sussex, United Kingdom, June 1941

In March 1941 Australian Tony Gaze joined No. 610 Squadron, part of Tangmere Wing led by Douglas Bader, together with his brother Scott who was killed shortly afterwards, on March 23, 1941. In October he was transferred to No. 57 OTU. In June 1942 he started his second tour of duty with No. 616 Squadron and in August he assumed command of No. 64 Squadron. On September 4, 1943, while flying with No. 66 Squadron he was shot down by Heinz-Gerhard Vogt from 7./JG 26. With the help of French Resistance he managed to avoid capture and returned back to England. In February 1944 he rejoined No. 610 Squadron, latter he shot down a V-1 flying bomb on August 5, 1944. In February 1945 he shot down a Me 262A. He joined No. 41 Squadron in April sharing a victory over Ar 234 on April 12. On May 2, 1945, he assumed command of flight of No. 616 Squadron where he flew Meteor Mk.III. After the war he was involved in car racing and became the first Australian racing in Formula 1.

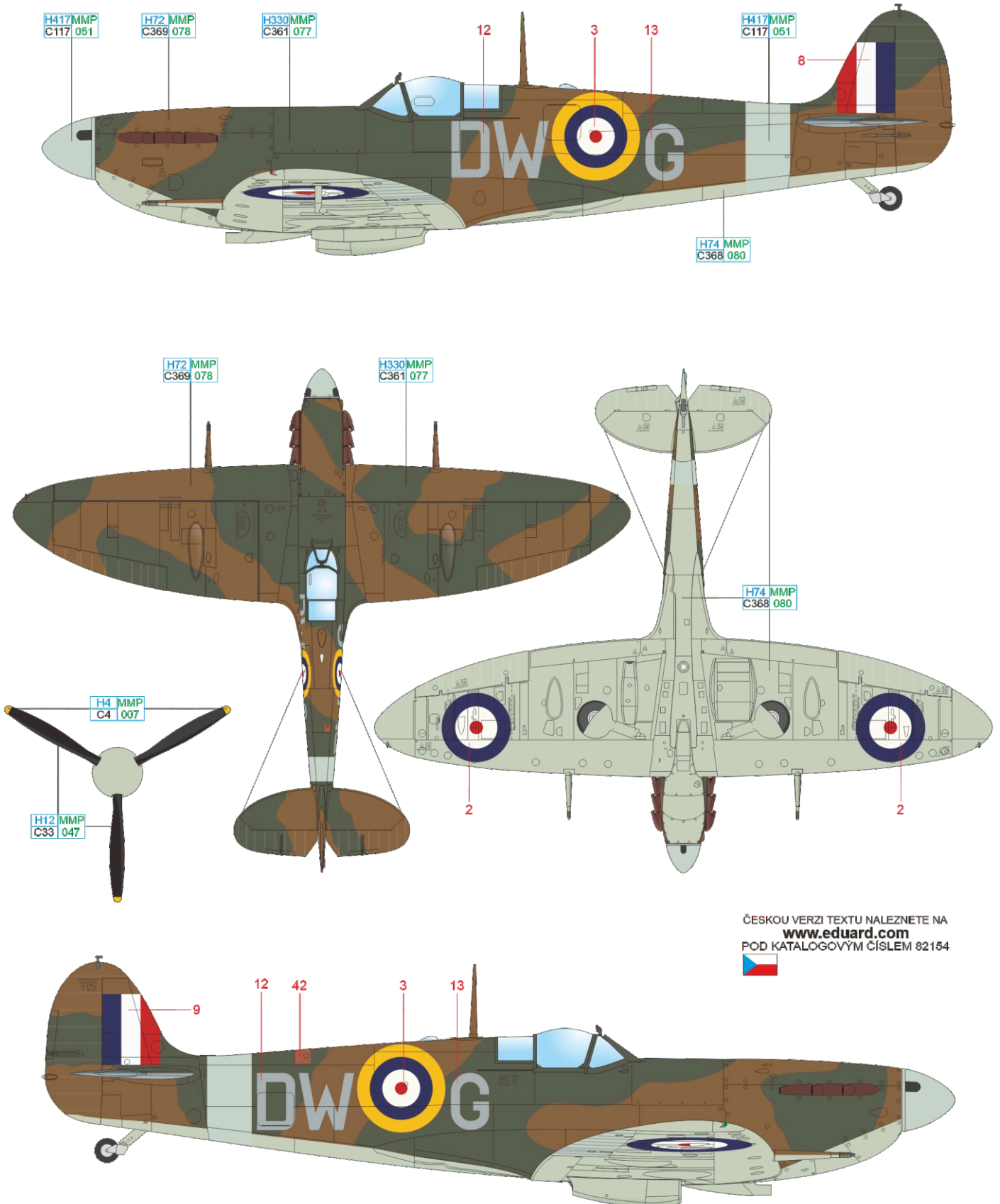

ČESKOU VERZI TEXTU NALEZNETE NA
www.eduard.com
 POD KATALOGOVÝM ČÍSLEM 82154



YELLOW	H4 MMP C4 007	BLACK	H12 MMP C33 047	LIGHT BLUEGREEN	H417MMP C117 051
DARK EARTH	H72 MMP C369 078	DARK GREEN	H330MMP C361 077	SKY	H74 MMP C368 080

B P8519, No. 306 (Polish) Squadron, RAF Northolt, United Kingdom, July 1941

No. 306 (Polish) Squadron (City of Torun), one of ten Polish fighter squadrons in the RAF, was established on August 28, 1940, at RAF Church Fenton. The squadron was formed from the pre-war Polish Toruński Dywizjon Myśliwski personnel and based on its traditions. In mid July 1941, the unit received Spitfires Mk.IIb to trade them for its Hurricanes Mk.IIa. Surprisingly, Polish squadrons operated quite a lot of cannon-armed Spitfires Mk.IIb. This aircraft carries the standard RAF camouflage (Temperate Land Scheme) dating from the first half of 1941. The upper surfaces are painted in Dark Green and Dark Earth, the lower surfaces are in Sky. The propeller spinner is in Sky color as well as the fuselage band in front of the tail surfaces. Note the red patch on the starboard fuselage spine covering the flare ejection channel. The majority of Spitfires Mk.IIb was equipped with de Havilland propeller, such as this aircraft.

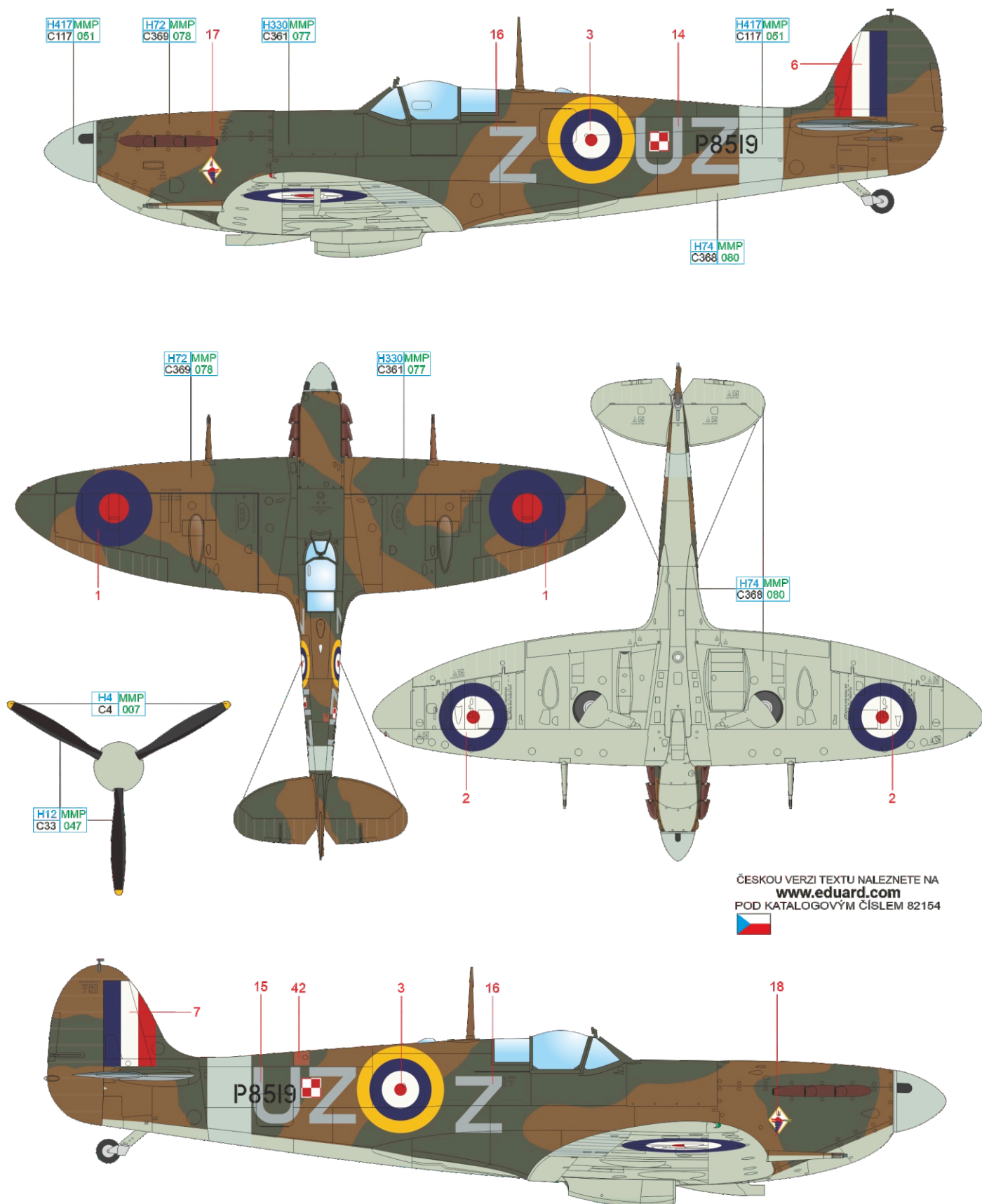

ČESKOU VERZI TEXTU NALEZNETE NA
www.eduard.com
 POD KATALOGOVÝM ČÍSLEM 82154



YELLOW	H4 MMP C4 007	BLACK	H12 MMP C33 047	LIGHT BLUEGREEN	H417MMP C117 051
DARK EARTH	H72 MMP C369 078	DARK GREEN	H330MMP C361 077	SKY	H74 MMP C368 080

C P8646, No. 616 (South Yorkshire) Squadron, RAF Kirton in Lindsey, Lincolnshire, United Kingdom, October/November 1941

This Spitfire Mk.IIb from No. 616 Squadron sports a new camouflage, Day Fighter Scheme, introduced on August 19, 1941. The upper surfaces were painted in Dark Green and Ocean Grey, the lower surfaces in Medium Sea Gray. The code letters were in Sky color as well as the fuselage band and the propeller spinner. The fin flash on the tail was of the low type, 27 inches high. The aircraft carried the donation inscription ROCHDALE AND DISTRICT 2 on the starboard side of the fuselage nose. It served with No. 616 Squadron from May 8, 1941, until January 15, 1942, when it was handed over to No. 331 (Norwegian) Squadron where it was coded FN-K. Some sources attribute this aircraft to P/O Colin Hodgkinson who, same as Douglas Bader, flew with leg prosthetics. It's probably a mistake since Colin Hodgkinson started his combat flying in September 1942 at No.131 Squadron.

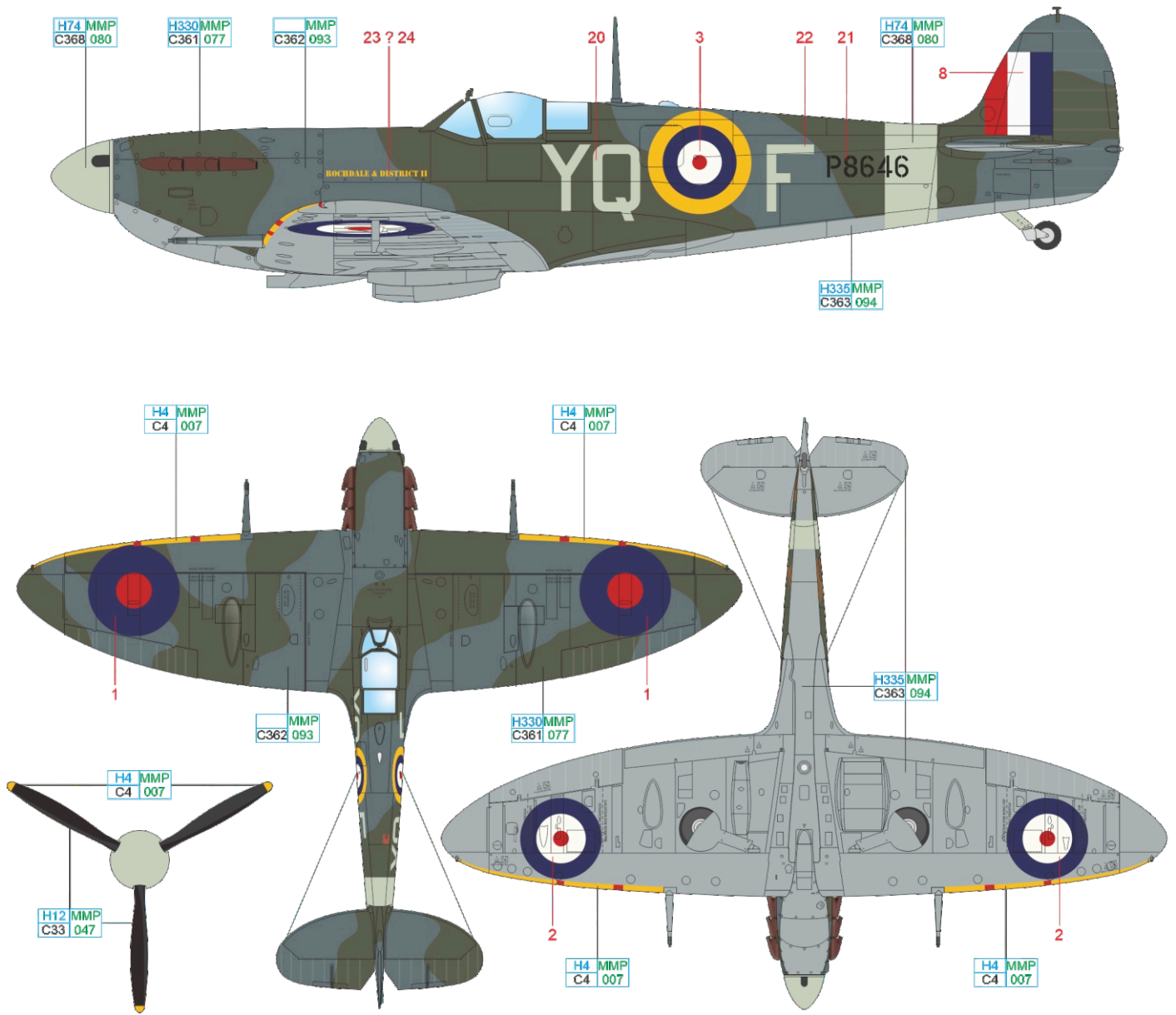

ČESKOU VERZI TEXTU NALEZNETE NA www.eduard.com
POD KATALOGOVÝM ČÍSLEM 82154

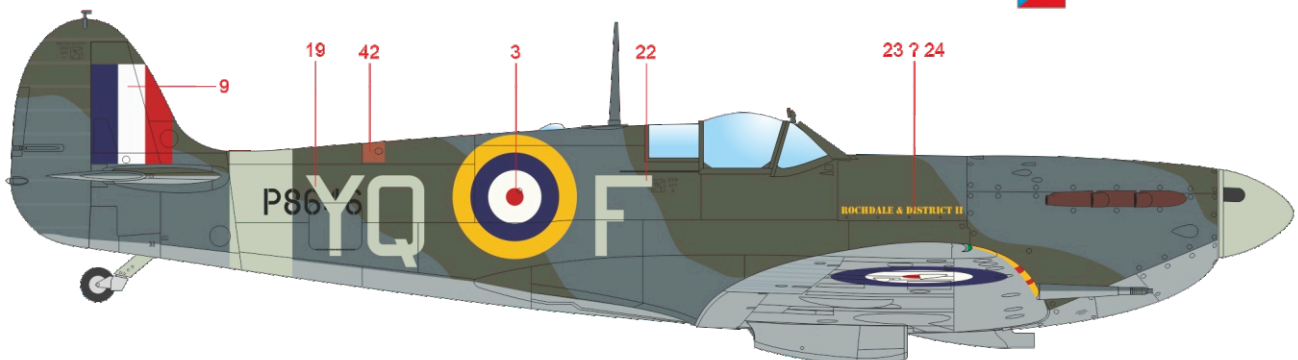

SKY	H74 MMP C368 080	YELLOW	H4 MMP C4 007	BLACK	H12 MMP C33 047
MEDIUM SEA GRAY	H335 MMP C363 094	OCEAN GRAY	MMP C362 093	DARK GREEN	H330 MMP C361 077

D P8505, Sgt. Eric S. Dicks-Sherwood, No. 266 (Rhodesia) Squadron, RAF Wittering, Cambridgeshire, United Kingdom, September 1941

Rhodesian Eric „Dickie“ Dicks-Sherwood commenced his service at No. 266 RAF Rhodesian Squadron in the summer of 1941 with the rank of Sergeant. In November he was promoted to Pilot Officer and transferred to No. 603 Squadron with which he sailed to Malta on board of USS Wasp aircraft carrier. Later he fought in Northern Africa and Italy. During the conflict he was credited with 2 shared and 5 individual victories. On September 15, 1941, he flew as a wingman to the Wittering Wing commander W/Cdr Jameson (RNZAF) on one of the Rhubarb missions against the De Kooy airport in the Netherlands. Over the ocean they were attacked by four Bf 110 from 5./ZG 76. Dicks-Sherwood claimed one enemy aircraft damaged, W/Cdr. Jameson claimed one shot down. In fact none of the enemy aircraft participating in the combat sustained any damage. P8505 sported the coat of arms of the city of Stamford on the port side of the fuselage and name *Eva III* on the starboard side.

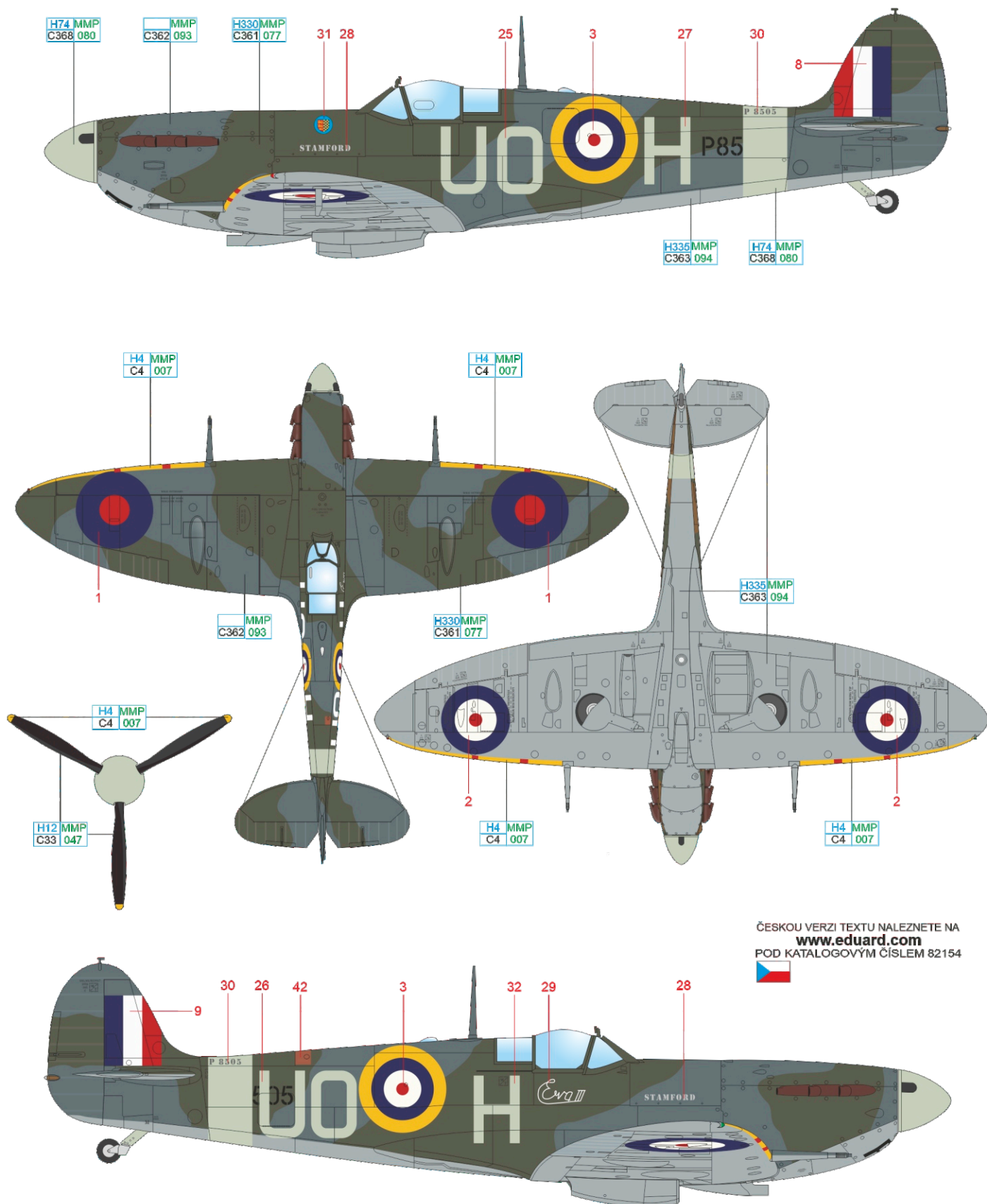

ČESKOU VERZI TEXTU NALEZNETE NA
www.eduard.com
 POD KATALOGOVÝM ČÍSLEM 82154



SKY	H74 MMP C368 080	YELLOW	H4 MMP C4 007	BLACK	H12 MMP C33 047
MEDIUM SEA GRAY	H335 MMP C363 094	OCEAN GRAY	MMP C362 093	DARK GREEN	H330 MMP C361 077

E P8533, S/Ldr. Percival S. Turner, CO of No. 145 Squadron, RAF Catterick, North Yorkshire, United Kingdom, October 1941

Canadian Percival Stanley Turner, a fighter ace of the Battle of Britain credited with 10 kills, was commanding No. 145 Squadron from April till October 1941. On August 30, 1941, his Spitfire Mk.IIb P8533 was handed over to No. 145 Squadron by No. 222 Squadron. The aircraft carried the newly introduced standard Day Fighter Scheme with upper surfaces in Dark Green and Ocean Grey and lower surfaces in Medium Sea Grey. The code letters were in Sky color as well as the fuselage band and propeller spinner. The Squadron Leader pennant was painted on the fuselage port side below the windshield. On December 8, 1941, this aircraft was handed over to No. 132 Squadron. It was equipped with de Havilland 5/39A constant speed propeller, same as the majority of Spitfires Mk.IIb.

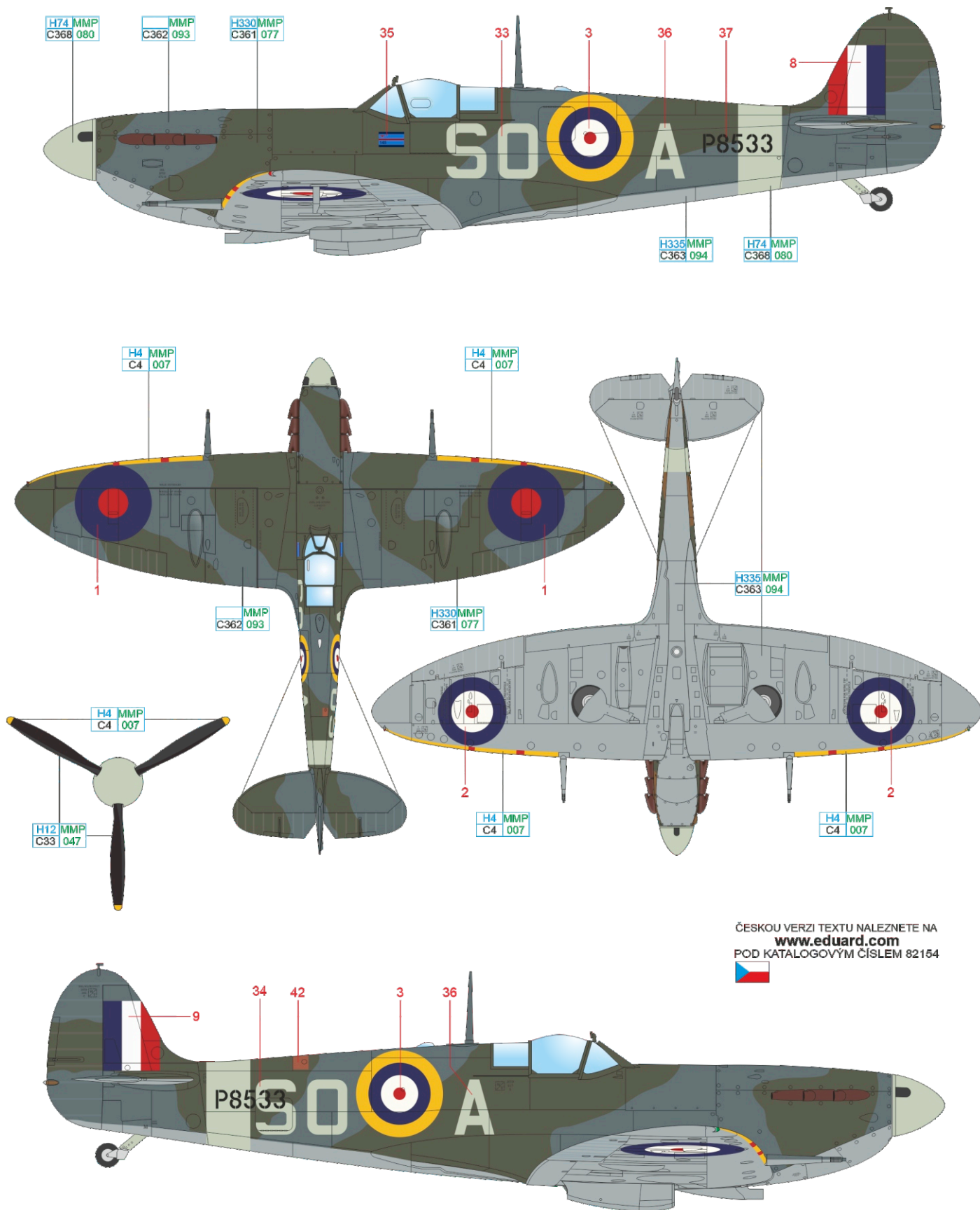

ČESKOU VERZI TEXTU NALEZNETE NA
www.eduard.com
 POD KATALOGOVÝM ČÍSLEM 82154



SKY	H74 MMP C368 080	YELLOW	H4 MMP C4 007	BLACK	H12 MMP C33 047
MEDIUM SEA GRAY	H335 MMP C363 094	OCEAN GRAY	MMP C362 093	DARK GREEN	H330 MMP C361 077

F P8348, No. 52 OTU, RAF Debden, Essex, United Kingdom, Summer 1943

In the beginning of 1942 the majority of Spitfires Mk.II was withdrawn from the combat units and replaced by new Spitfires Mk.Vb. The surviving aircraft were assigned to the training units, Operational Training Units-OTU. Surprisingly they served there for quite a long time, for example this P8348, initially manufactured as Mk.IIa in April 1941, was struck off charge as late as September 25, 1945. Presented here as it appeared in the summer 1943 when it was overhauled and then served with No. 52 OTU, it carries the standard Day Fighter Scheme camouflage and new national insignia introduced in May 1942. There is a donation inscription BRITISH AND FRIENDS EX JAPAN on the fuselage nose and the propeller is typical for Spitfires Mk.IIb, de Havilland 5/39A constant speed.

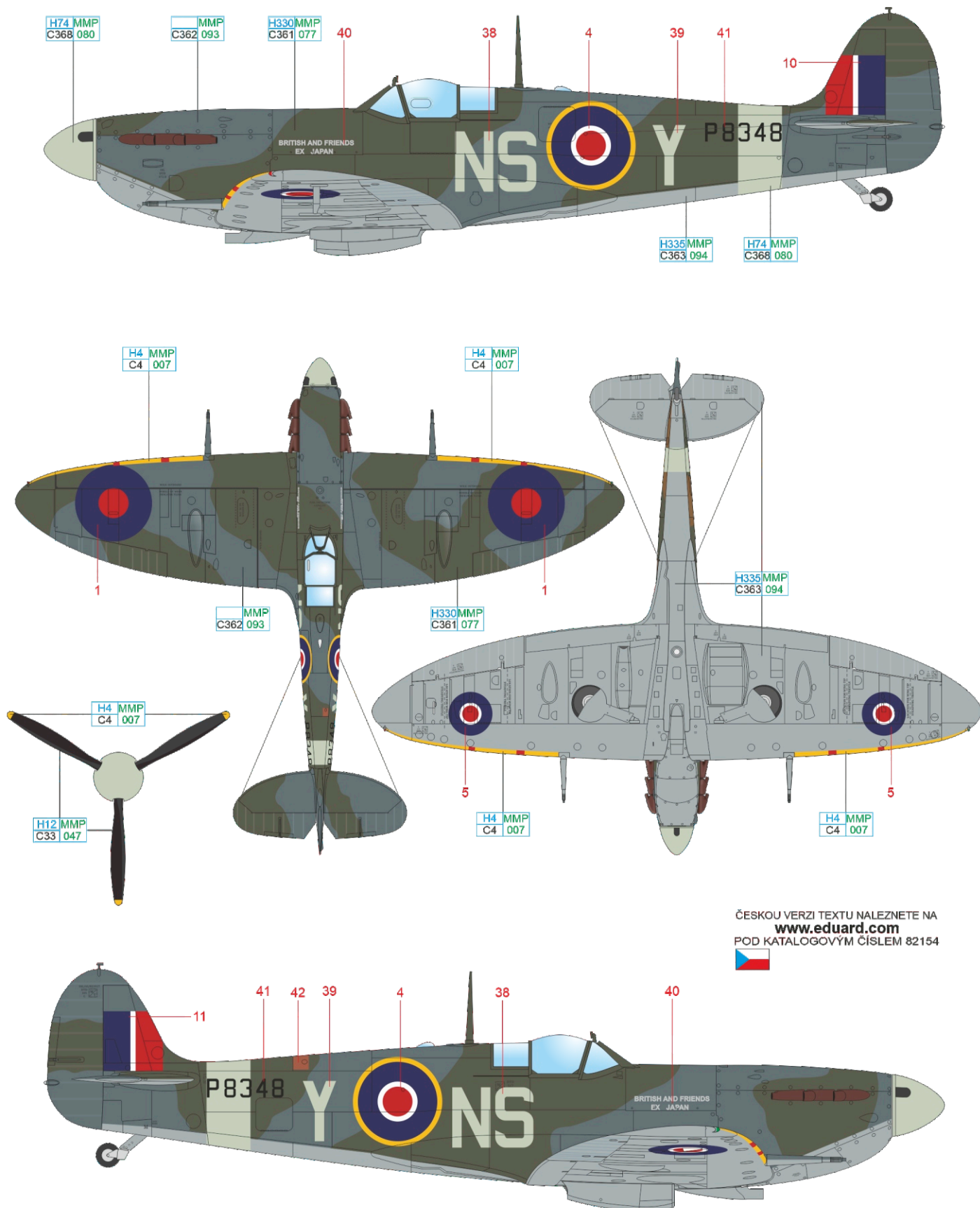

ČESKOU VERZI TEXTU NALEZNETE NA
www.eduard.com
 POD KATALOGOVÝM ČÍSLEM 82154



SKY	H74 MMP C368 080	YELLOW	H4 MMP C4 007	BLACK	H12 MMP C33 047
MEDIUM SEA GRAY	H335 MMP C363 094	OCEAN GRAY	MMP C362 093	DARK GREEN	H330 MMP C361 077