

1/48 SCALE PLASTIC KIT

ProfiPACK
edition

#82161



INTRO

No other aircraft of the German Luftwaffe is so intimately connected with its rise and fall in the course of the Second World War than the Messerschmitt Bf 109. This type, by whose evolution outlived the era in which it was conceptualized, bore the brunt of Luftwaffe duties from the opening battles of Nazi Germany through to her final downfall. The history of the aircraft begins during 1934-35, when the Reich Ministry of Aviation formulated a requirement for the development of a single-engined monoplane fighter. Proposals were submitted by Arado, Heinkel, Focke-Wulf and Bayerische Flugzeugwerke. The last mentioned firm featured a technical director named Professor Willy Messerschmitt, who was riding a wave of popularity based on the success of his recent liaison aircraft, the Bf 108. His goal was to conceive of an aircraft with the best possible performance for the specified weight, size, and aerodynamic qualities. Over the subsequent months, several prototypes were built that served first and foremost in development flights and further modifications. The aircraft was relatively small, and compared to the prevailing trends of the time, docile with revolutionary features such as low wing design, the use of a retractable landing gear, a wing with a very narrow profile, wing slats, landing flaps, weapons firing through the prop hub, and so on. Even the enclosed cockpit and the method of construction were not very common just four years prior to the beginning of the Second World War. At its conception, the Bf 109 was a very promising asset despite some powerplant troubles. These were solved by the introduction of the DB 601. This engine, together with its extrapolated development DB 605, is umbilically connected to the types success. These two-row, twelve cylinder inverted V engines powered several tens of thousands of 109s in over 25 versions and variants.

The first combat use was by three developmental Bf 109s in the Spanish Civil War, where they were delivered in December 1936. The pre-series airframes were to, first of all, validate the aircraft's abilities in modern aerial combat. Shortly thereafter, production machines in the form of the Bf 109B-1 began to reach 2./J/88, the Legion Condor. The desire of Germany to demonstrate her aerial prowess to potential foes was advanced further in international sport meets. The triumphs attained in Zurich in the summer of 1937 were complemented several months later by grabbing the speed record of 610.95 kph. In very short order, the progressive developments represented by the C, D and E versions appeared. Despite this, the delivery of the types to combat units did not sustain a rate that was desired by military brass. Even by August 1938 the Bf 109 accounted for less than half of the 643 front line fighters in service. The later months saw an increase in these rates. By the time of the invasion of Poland (which saw the participation of only a little more than 200 aircraft) the Luftwaffe possessed the best fighter produced in continental Europe. With both a qualitative and quantitative advantage, the fighter wing of the Luftwaffe entered the Polish campaign, the first defenses of the Fatherland, Blitzkrieg against the West, and the Battle for France. With one foot in the door that was the English Channel, the Luftwaffe embarked on the attacks on Britain in the summer months of 1940. Here, the first weakness of the Bf 109 was revealed: the inability to carry drop tanks that would have enabled the type to effectively escort bombers to England. This was one of the factors that made the defeat of the Luftwaffe in the Battle of Britain possible. Experiences gained in 1940 led to the development of the 'F' version prior to the spring of 1941. The elegance of the Bf 109 crested with the 'Friedrich'. Following a largely defensive stance over the Channel and northern France, the Bf 109F took on a more offensive role in Operation Barbarossa in the east, and in northern Africa. In later duties with the 'Jagdwaaffe' during the second phase of the war in the east, and in the 'Defense of the Reich' from 1943 to 1945, the Bf 109 served in the form of the 'G' version, followed by the 'K'. Even if by the end of the war it was clear that the development of the Bf 109 was exhausted, during its combat career, the type was able to keep pace with the foes that it encountered. Besides its primary function as fighter, the Bf 109 also appeared as a fighter-bomber, reconnaissance platform, night fighter, trainer and Rammjäger.

The disappearance of the Bf 109 from the skies over Europe was not spelled out by the end of the war. Several examples were in Swiss service up to 1949, and many flew in the air force of Czechoslovakia in both original form with a DB 605 powerplant and as aircraft built out of necessity with surplus Jumo 211s. The latter type also served as the first fighter to fight for the independence of the newly formed state of Israel. Finland retired the type as recently as 1954, and Spain didn't retire its HA-1109-1112, re-engined Bf 109s, until 1967. The legendary low-wing fighter of Professor Willy Messerschmitt survived the state that developed it.

ÚVODEM

Žádný jiný stroj německé Luftwaffe není výrazněji spojen s jejím vzestupem a pádem ve 2. světové válce, než stíhací Messerschmitt Bf 109. Letoun, který svou koncepcí výrazně předběhl dobu, ve které vznikl, se stal tahounem stíhacího letectva od prvních válečných konfliktů nacistického Německa, až do jeho hořkého konce. Historie letounu se začíná v období let 1934-35, kdy Říšské ministerstvo letectví formulovalo specifikace zakázky na vývoj jednomotorové jednoplošné stíhačky. Projektu se zúčastnily firmy Arado, Heinkel, Focke-Wulf a Bayerische Flugzeugwerke. V poslední jmenované působil na postu technického ředitele profesor Willy Messerschmitt, jehož popularita se nesla na vlně úspěchu nedávno dokončeného kurýrního Bf 108. Jeho cílem bylo vytvořit letoun s co největším poměrem výkonu k celkové hmotnosti, velikosti a aerodynamickým vlastnostem. V průběhu následujících měsíců vzniklo několik prototypů, které sloužily zejména ke zkouškám a dalšímu vývoji. Letoun byl poměrně malý, oproti stávajícím zvyklostem relativně jemný, s revolučními konstrukčními prvky jako byla dolnokřídla koncepcí, použití zatahovacího podvozku, křídlo s velmi štíhlým profilem, pohyblivé sloty, vztlakové klapky, zbraně střelící osou vrtule, atd.

Dokonce uzavíratelný překryt kabiny nebo skofepinová konstrukce nebyly čtyři roky před začátkem 2. světové války tak obvyklým jevem, jak by se z dnešního pohledu mohlo zdát. Bf 109 byl již z počátku svého vývoje, i přes problémy s pohonnou jednotkou, velmi nadějným projektem. Problémy s pohonem vyřešila až zástavba motoru DB 601. Ten je spolu s pozdějším DB 605 neodmyslitelně spojen s úspěchy Bf 109. Řadový invertní dvanáctiválec do V poháněl několik desítek tisíc vyprodukovaných „stodevíték“ ve více než 25 verzích a variantách. K prvnímu bojovému nasazení tří zkušebních kusů Bf 109 došlo za občanské války ve Španělsku, kam byly odeslány v prosinci 1936. Stroje z před sériové výroby měly především ukázat schopnosti letounu v moderní letecké válce. Následně se do bojového nasazení u 2./J/88 Legion Condor začaly dostávat i sériové stroje varianty Bf 109B-1. Snaze Německa ukazovat svou leteckou sílu potenciálním protivníkům napomáhala i sportovní klání. Triumf letounů Bf 109 na leteckém mítinku v Curychu v létě 1937 byl doplněn o několik měsíců později ustanovením rychlostního rekordu 610,95 km/h. Ve velmi krátkých časových úsecích následovaly verze C, D a E. Přesto však doplňování nových strojů k bojovým útvarům nepokračovalo tempem, který by si velení mohlo přát. Ještě v srpnu roku 1938 tvořila výzbroj letouny Bf 109 méně než polovinu z 643 stíhaček první linie. Ovšem během následujících měsíců roku se tempo dodávek k bojovým útvarům zrychlilo. V okamžik přepadení Polska (kterého se však zúčastnilo jen o málo více než dvě stě Bf 109) tak Luftwaffe disponovala zajisté nejlepší stíhačkou, jaká byla v kontinentální Evropě vyrobena. S technickou i množství převahou tak stíhací část Luftwaffe absolvovala polskou kampaň, první obranu Vaterlandu, Blitzkrieg proti západu i bitvu o Francii. S jednou nohou vykročenou přes kanál La Manche zahájila Luftwaffe v letních měsících roku 1940 útoky na Británii. V tu dobu se mj. projevil jeden vážný nedostatek Bf 109 - nepřipravenost konstrukce stroje na nesení přídavné nádrže, která by zvýšila dolet letounu při doprovodu bombardérů nad Británií. Tato zdánlivá maličkost byla jedním z faktorů, které zapříčinily porážku Luftwaffe v Bitvě o Británii. Zkušenosti z bojů v r. 1940 napomohly při vývoji verze F, která se začala k bojovým útvarům dostávat během předjaří 1941. Elegance Bf 109 u „Friedricha“ dosáhla vrcholu. Po bojích nad Kanálem a severní Francií, spíše již defenzivního charakteru, se Bf 109F zapojily i do útočných akcí, a to zejména při operaci Barbarossa na východě nebo v severní Africe. Do pozdějších úkolů Jagdwaaffe ve druhé fázi války na východě i do obrany Říše v letech 1943 - 1945 se zapojovaly především Bf 109 verze G a v posledních měsících války pak také verze K. Ačkoli na konci války bylo jasné, že koncepce letounu Bf 109 se po deseti letech služby dostala na hranici možností, po celou dobu své bojové činnosti dokázaly jednotlivé varianty držet krok se svými stíhacími protivníky. Kromě svého prioritního určení stíhacího letounu se Bf 109 objevily i v rolích stíhací-bombardovací, průzkumná, noční stíhací, palubní stíhací, cvičné nebo jako Rammjäger.

Nebe se pro Bf 109 nezavřelo ani po skončení války. Několik strojů sloužilo až do roku 1949 ve Švýcarsku, mnohé létaly v balkánských zemích, v osvobozeném Československu, a to jak v původní podobě s motory DB 605, tak v přestavěné variantě s motory Jumo 211. Zejména tyto stroje později tvořily základ letectva bráničí svobodu nové budovaného státu Izrael. Finsko zrušilo Bf 109 až v roce 1954 a Španělsko opustilo své HA-1109 a 1112 dokonce až v roce 1967.

ATTENTION



UPOZORNĚNÍ



ACHTUNG



ATTENTION



注意



Carefully read instruction sheet before assembling. When you use glue or paint, do not use near open flame and use in well ventilated room. Keep out of reach of small children. Children must not be allowed to suck any part, or pull vinyl bag over the head.



Před započítím stavby si pečlivě prostudujte stavební návod. Při používání barev a lepidel pracujte v dobře větrané místnosti. Lepidla ani barvy nepoužívejte v blízkosti otevřeného ohně. Model není určen malým dětem, mohlo by dojít k požití drobných dílů.

INSTRUCTION SIGNS * INSTR. SYMBOLS * INSTRUKTION SINNBILDEN * SYMBOLES * 記号の説明

OPTIONAL
VOLBABEND
OHNOUTSAND
BROUSITOPEN HOLE
VYVRTAT OTVORSYMETRICAL ASSEMBLY
SYMETRICKÁ MONTÁŽREMOVE
ODŘÍZNOUTREVERSE SIDE
OTOČITAPPLY EDUARD MASK
AND PAINT
POUŽIT EDUARD MASK
NABARVIT

PARTS



DÍLY



TEILE



PIÈCES



部品

PLASTIC PARTS

H>

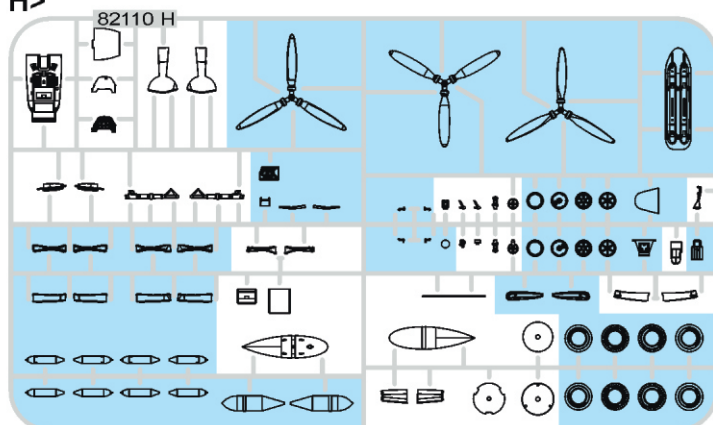

I>

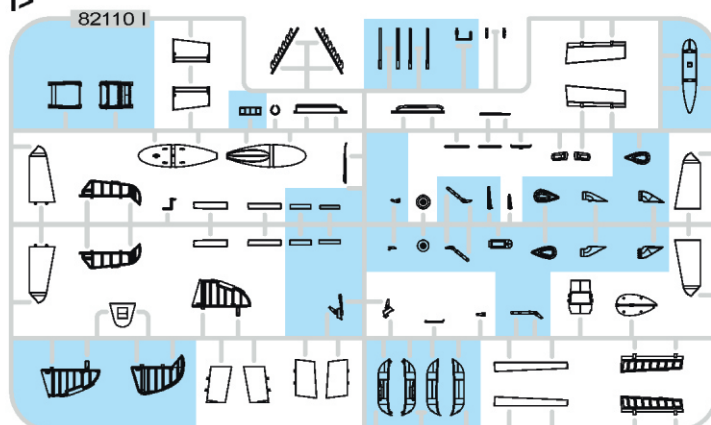

U>

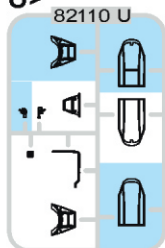

Y>



82110 Y

X>

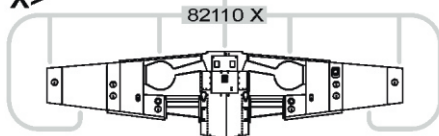

82110 X

W>

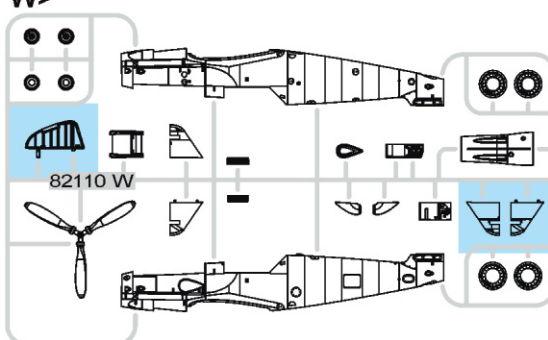

PE - PHOTO ETCHED DETAIL PARTS

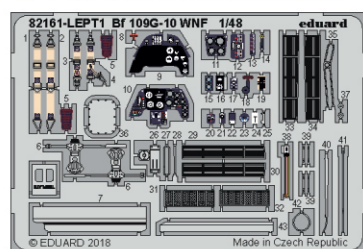
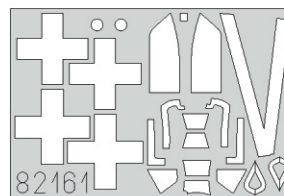
eduard
MASK

-Parts not for use. -Teile werden nicht verwendet. -Pièces à ne pas utiliser. -Tyto díly nepoužívejte při stavbě. - 使用しない部品

COLOURS



BARVY



FARBEN



PEINTURE



色

GSI Creos (GUNZE)		MISSION MODELS	
AQUEOUS	Mr.COLOR	PAINTS	
H2	C2	MMP-047	BLACK
H5	C5	MMP-048	BLUE
H11	C62	MMP-001	FLAT WHITE
H12	C33	MMP-047	FLAT BLACK
H47	C41	MMP-012	RED BROWN
H65	C18	MMP-088	RLM70 BLACK GREEN
H68	C36	MMP-049	RLM74 DARK GRAY
H69	C37	MMP-050	RLM75 GRAY
H70	C60	MMP-056	RLM02 GRAY
H77	C137	MMP-040	TIRE BLACK
H90	C47		CLEAR RED

GSI Creos (GUNZE)		MISSION MODELS	
AQUEOUS	Mr.COLOR	PAINTS	
H94	C138		CLEAR GREEN
H413	C113	MMP-090	RLM04 YELLOW
H416	C116	MMP-089	RLM66 BLACK GRAY
H417	C117	MMP-051	RLM76 LIGHT BLUE
H421	C121	MMP-052	RLM81 BROWN VIOLET
H423	C123	MMP-054	RLM83 DARK GREEN
Mr.METAL COLOR		METALLICS	
	MC213	MMM-006	STEEL
	MC214	MMM-001	DARK IRON
Mr.COLOR SUPER METALLIC		METALLICS	
	SM01	MMC-001	SUPER CHROME

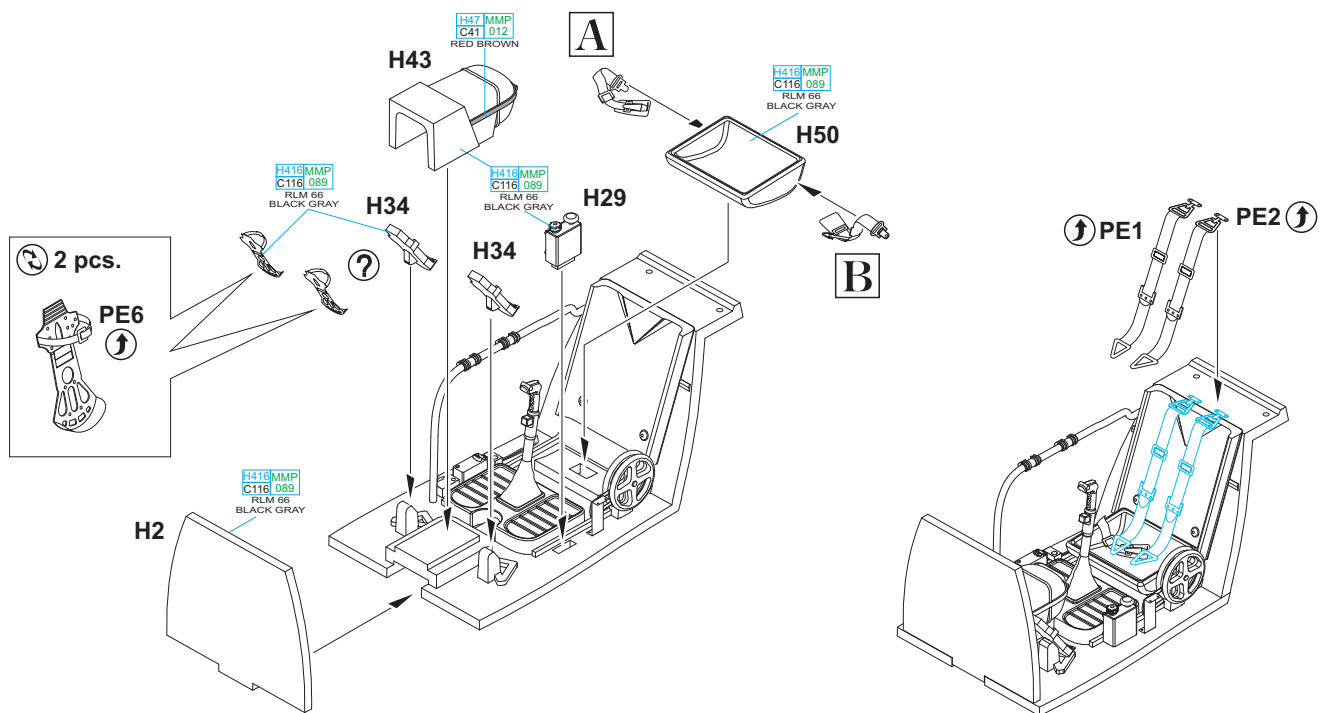
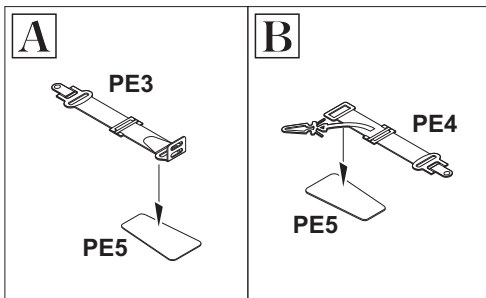
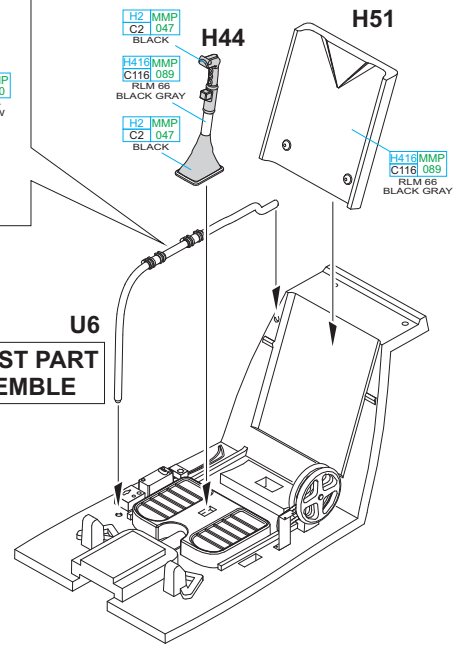
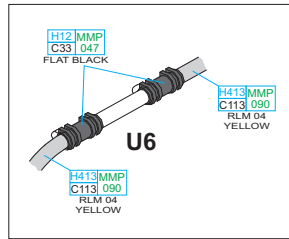
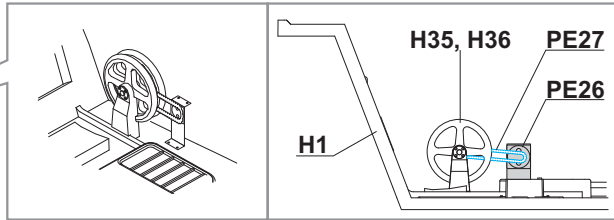
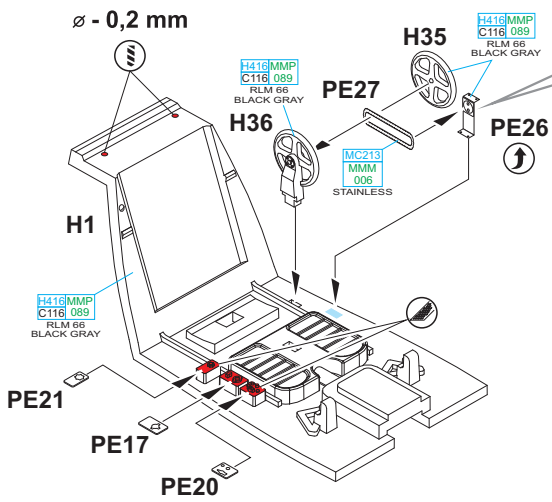

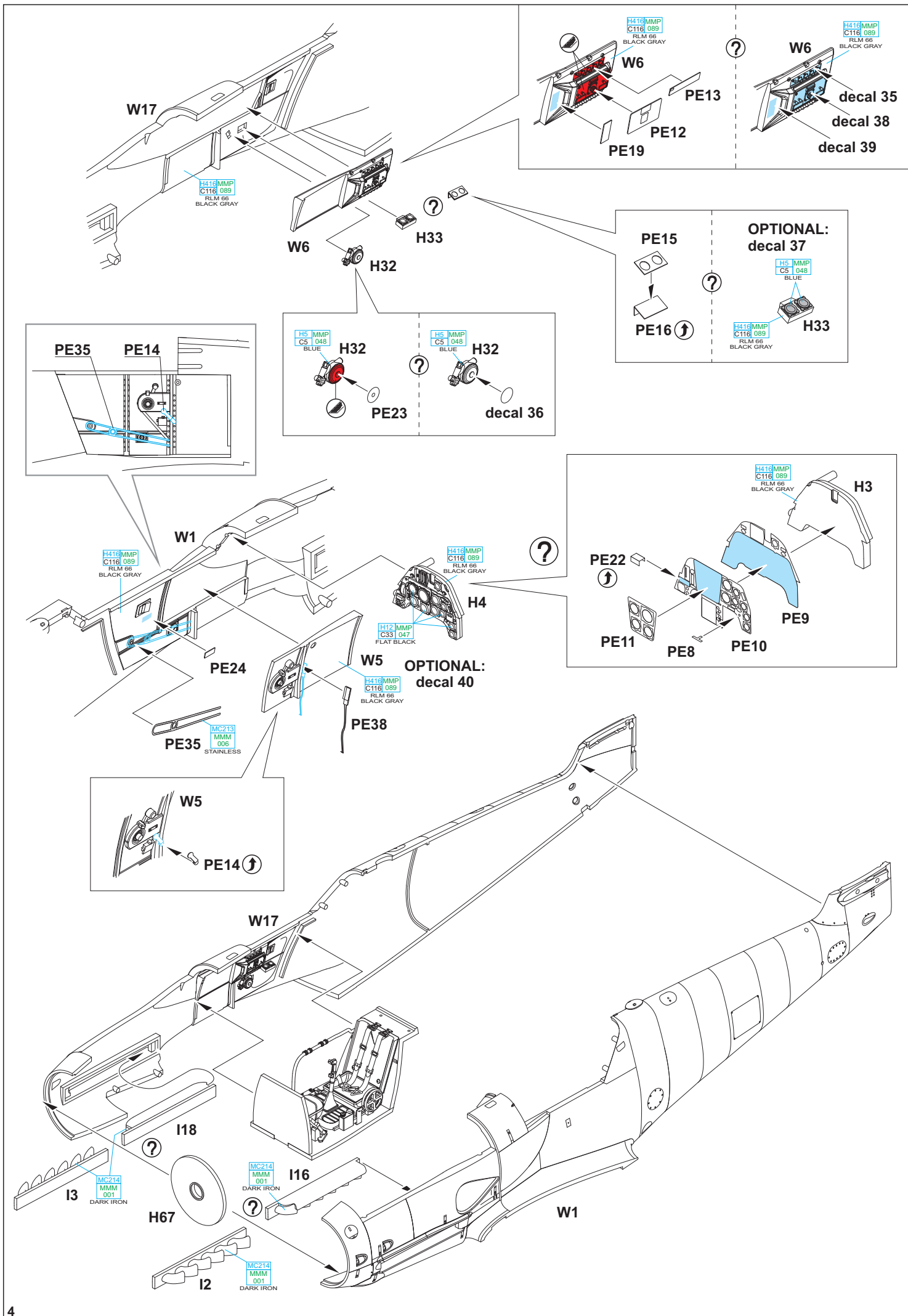

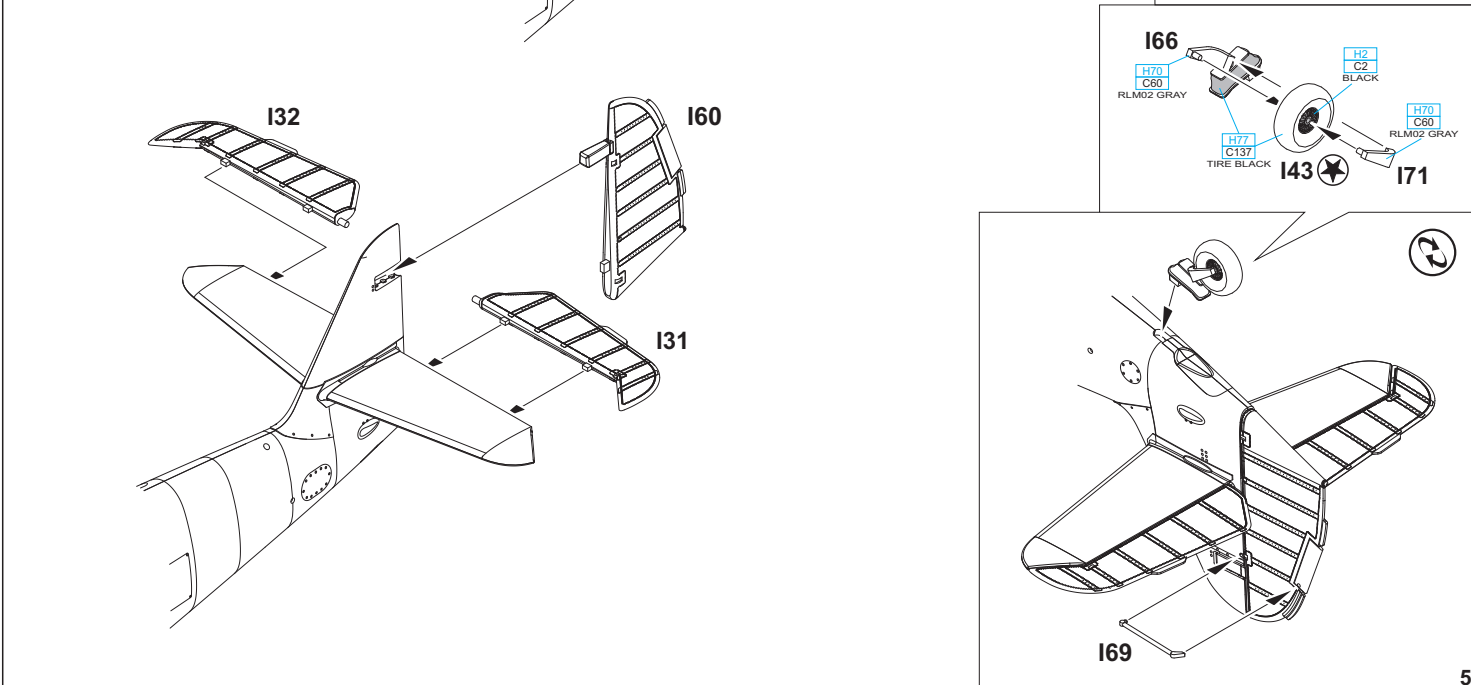
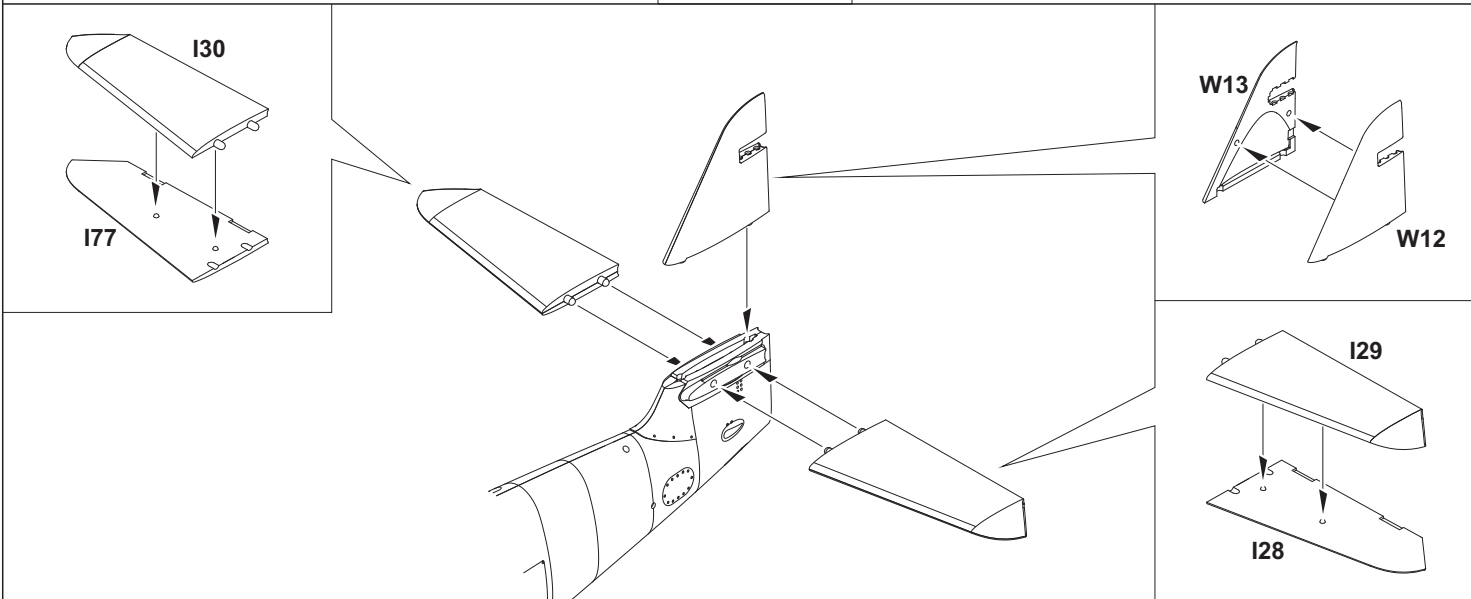
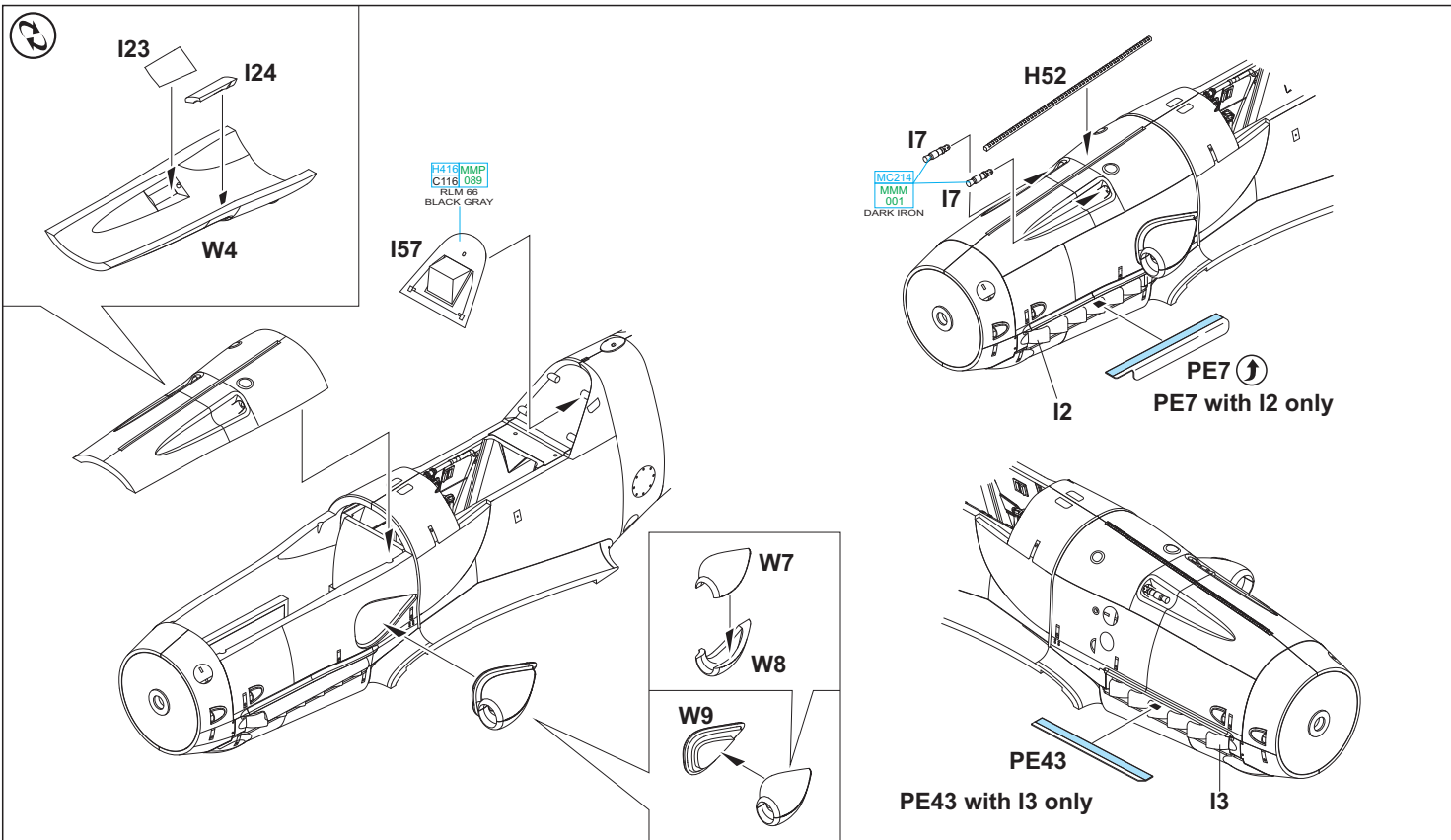

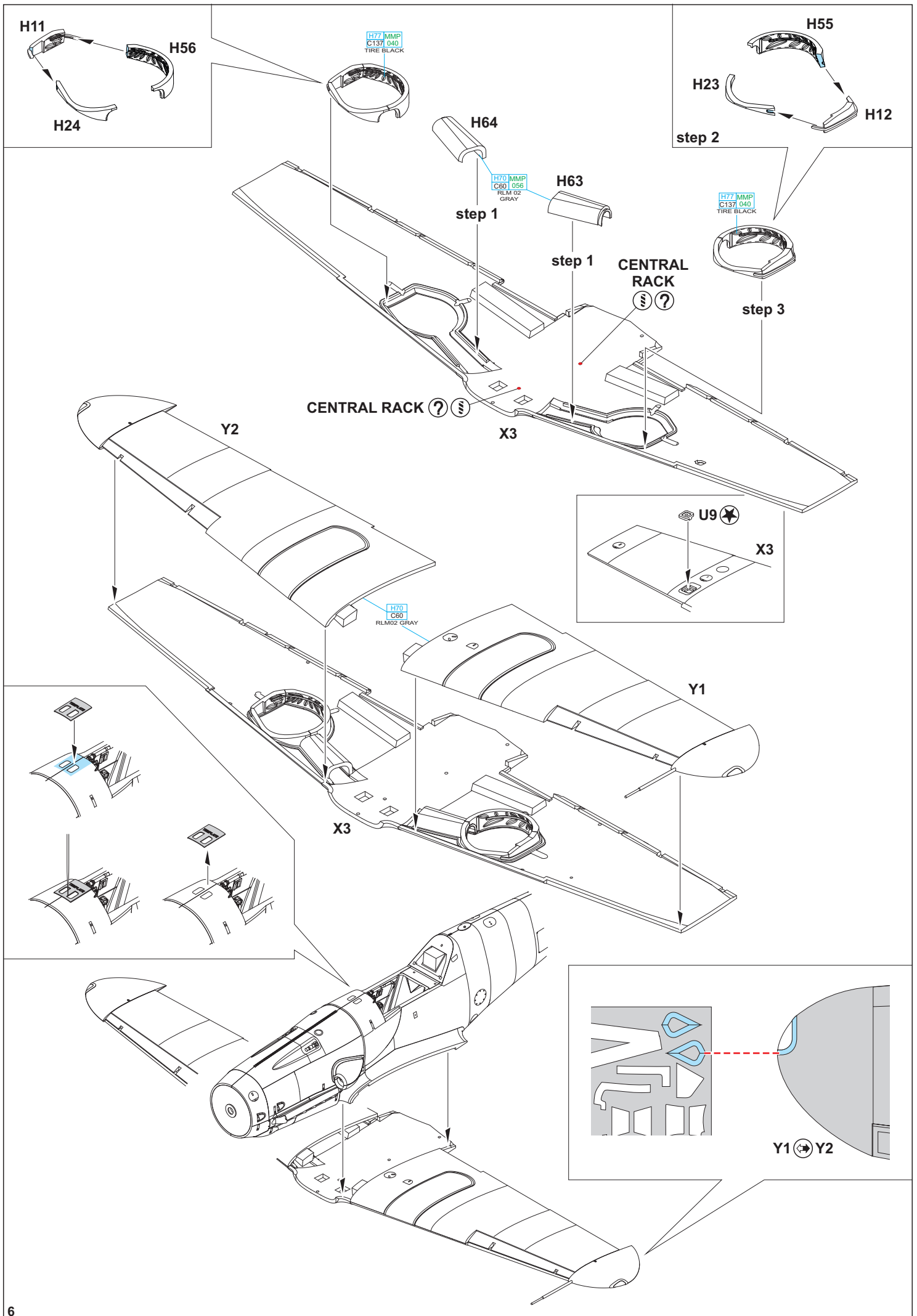

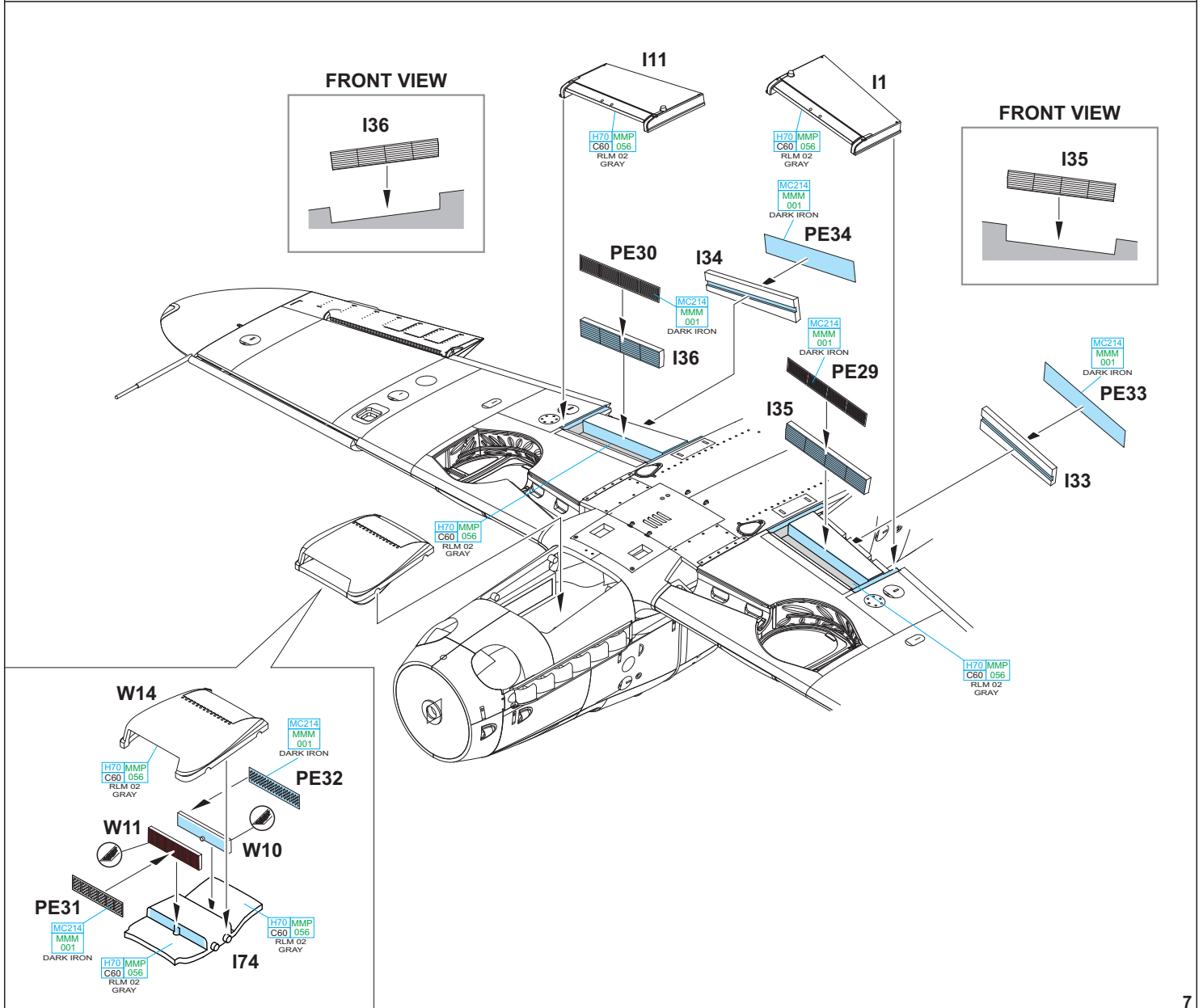
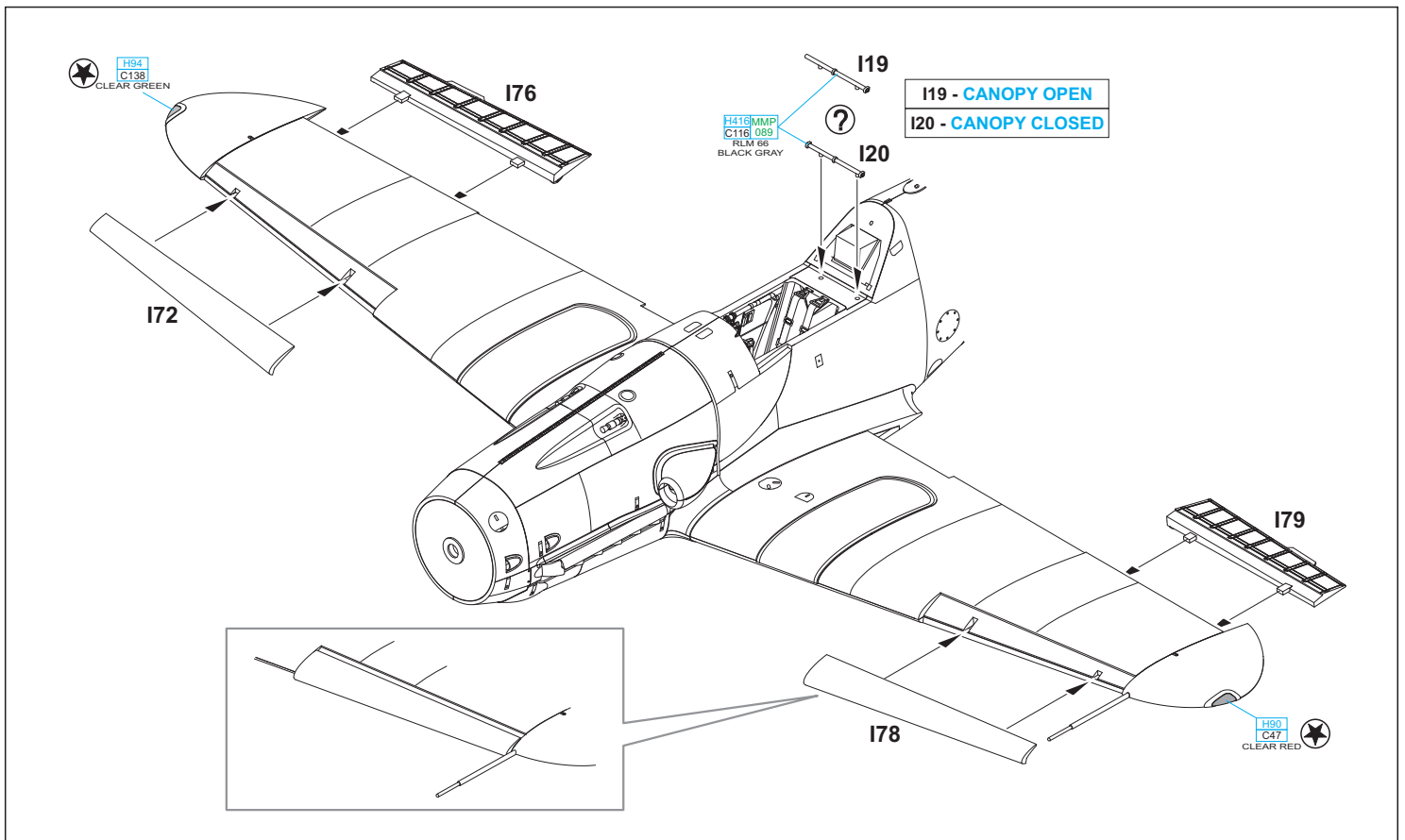

CORRECT POSITION OF RADIATOR FLAPS

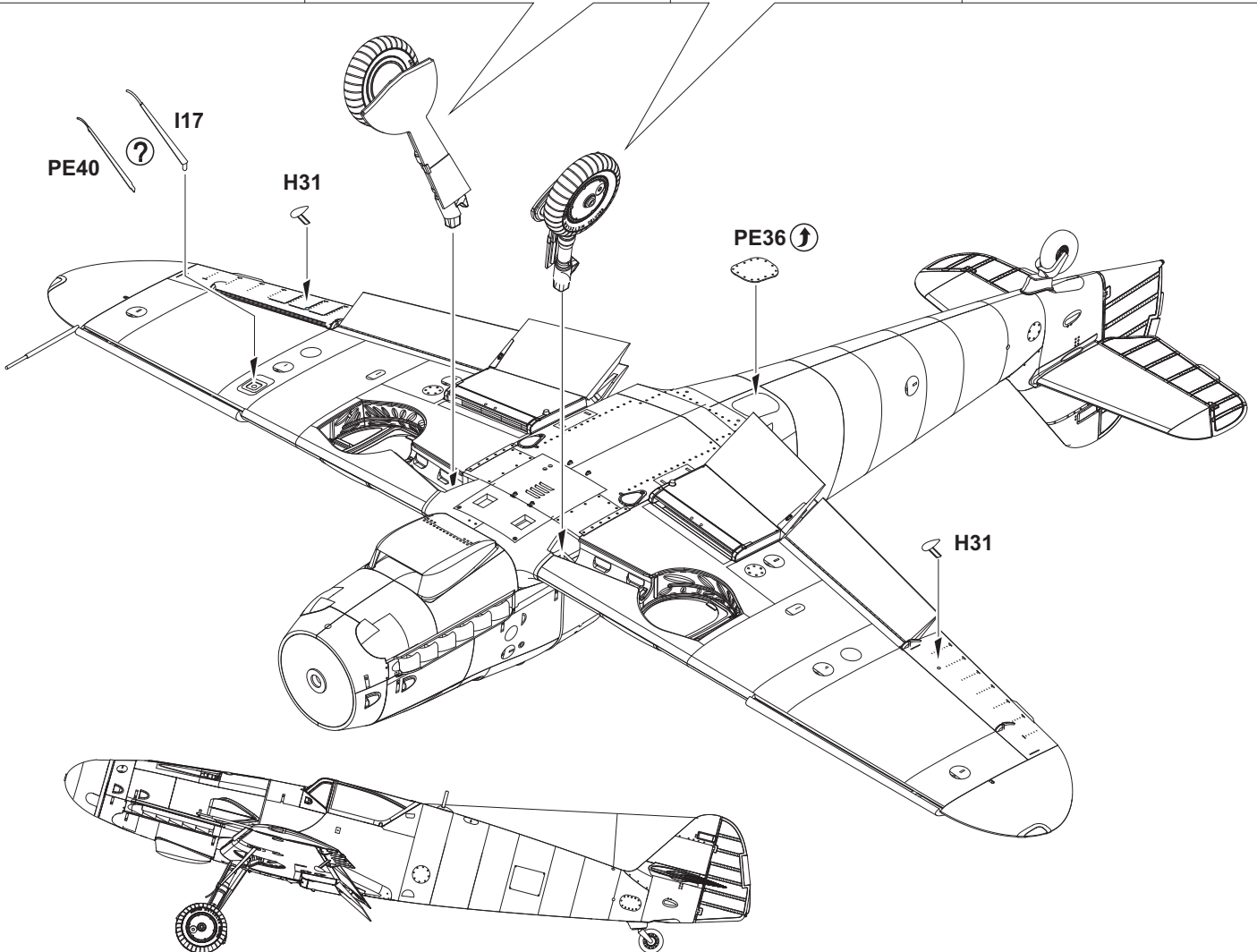
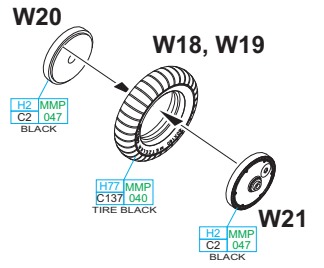
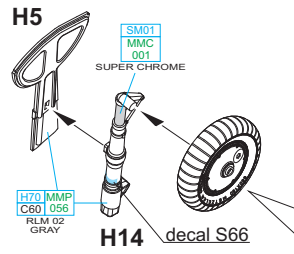
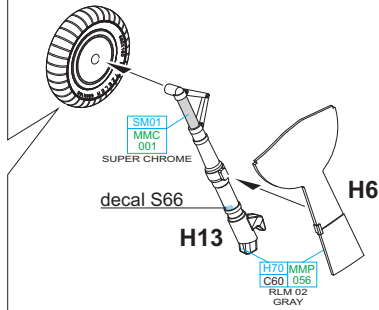
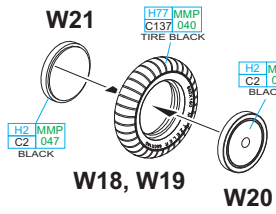
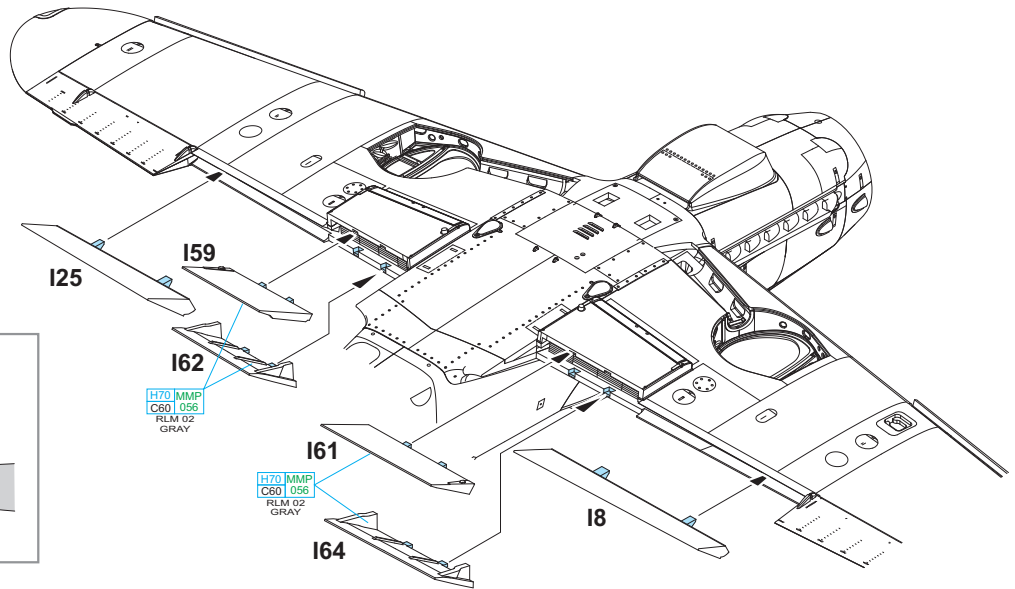
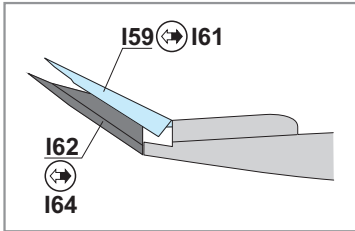

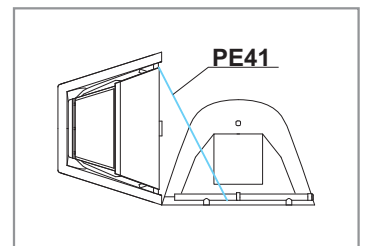
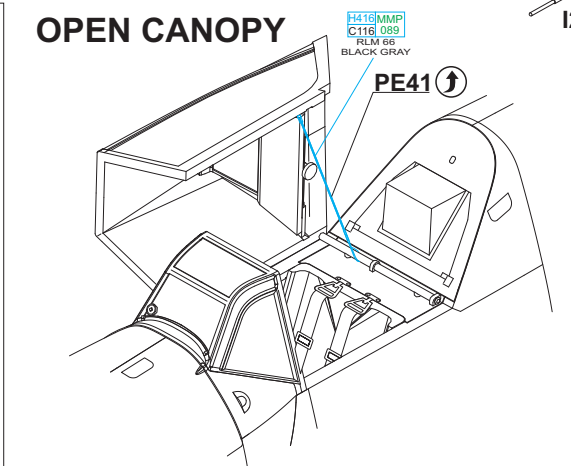
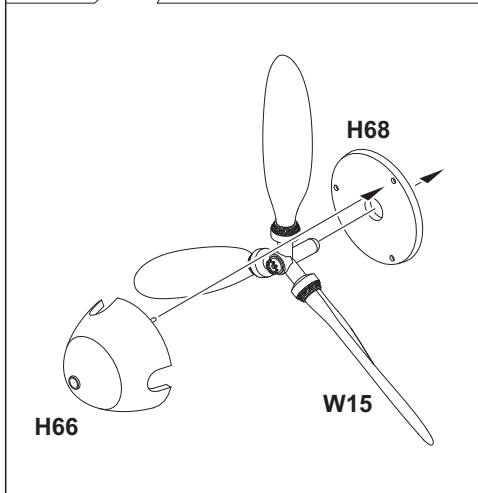
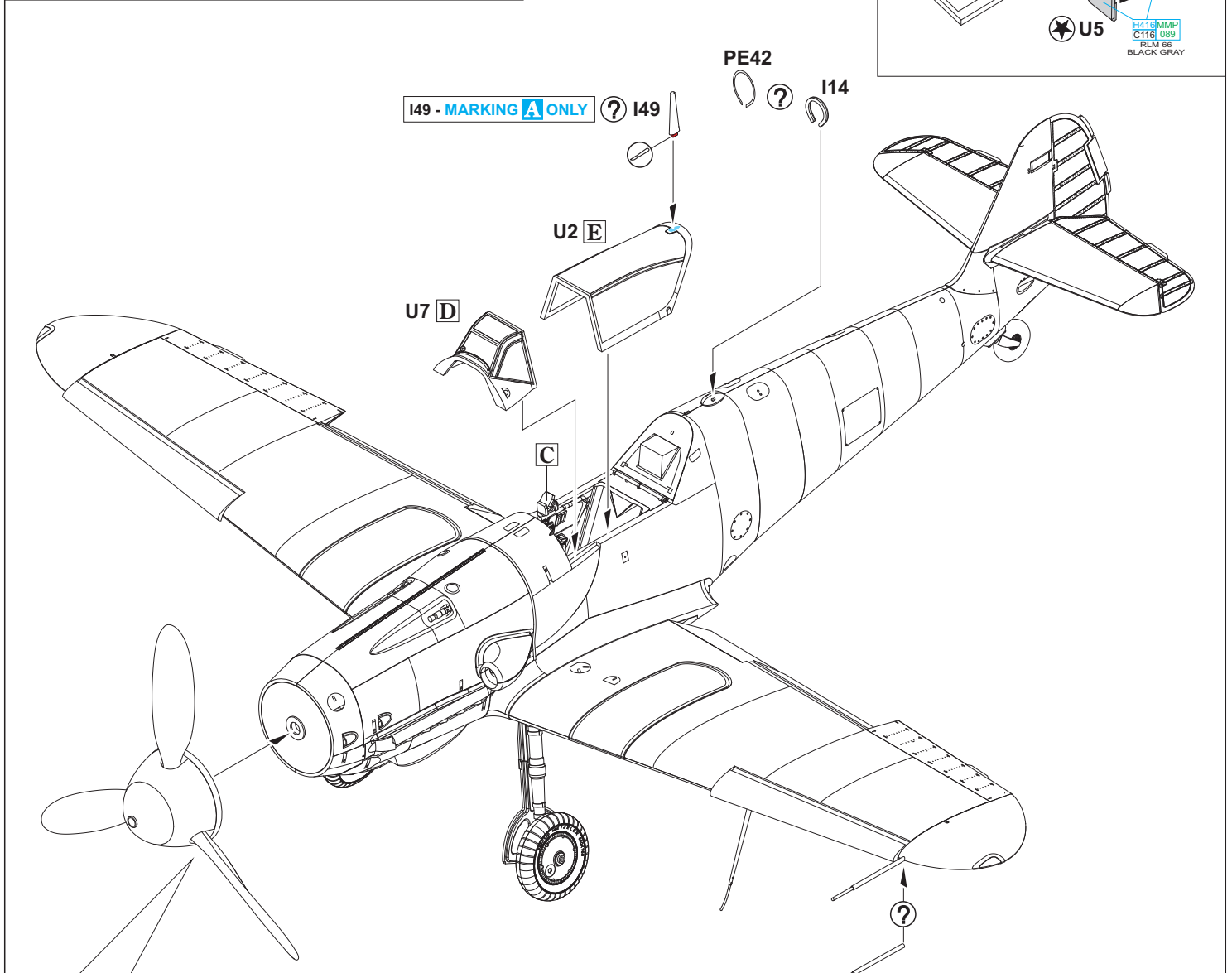
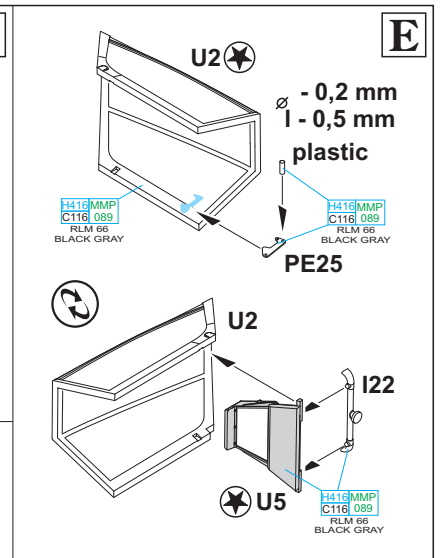
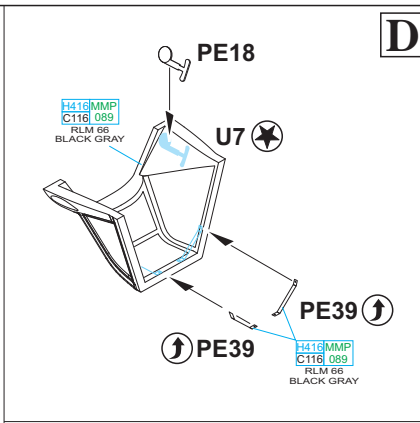
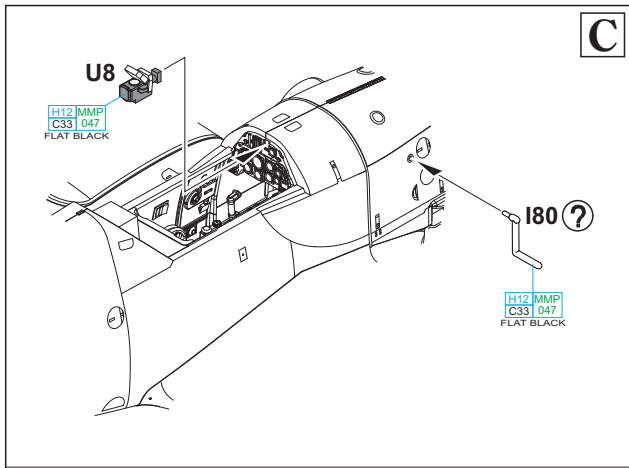

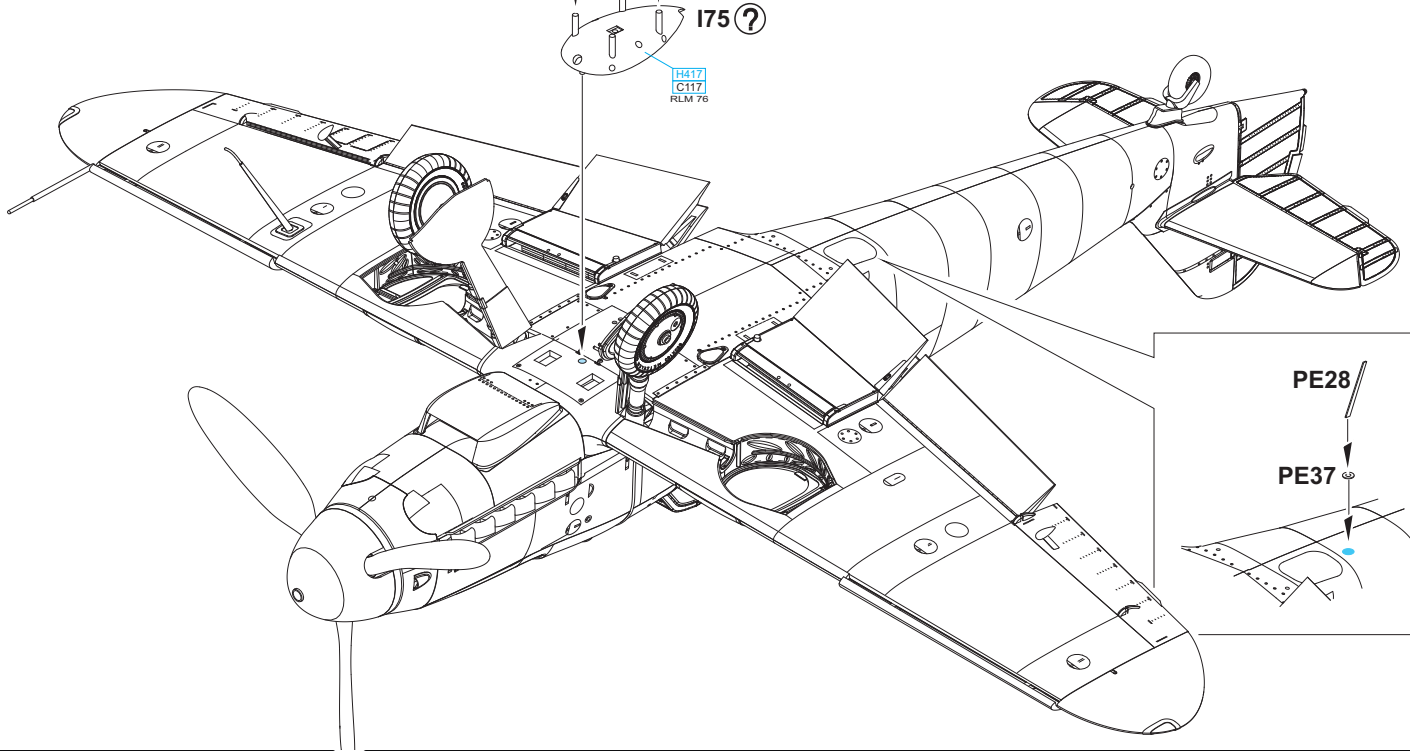
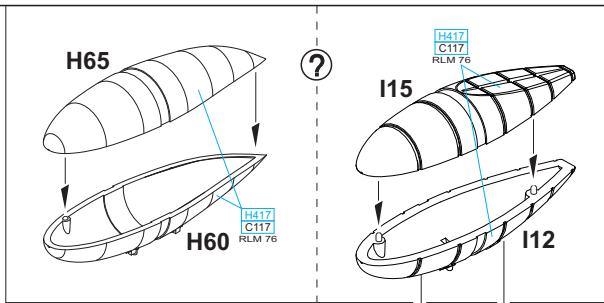

eduard
MASK
82161

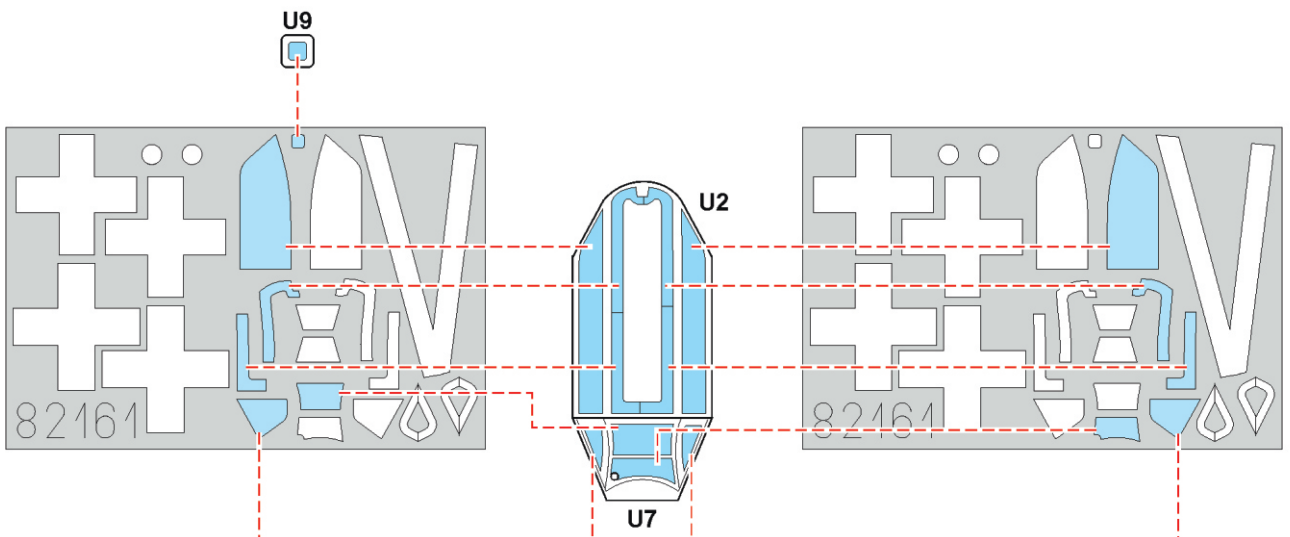
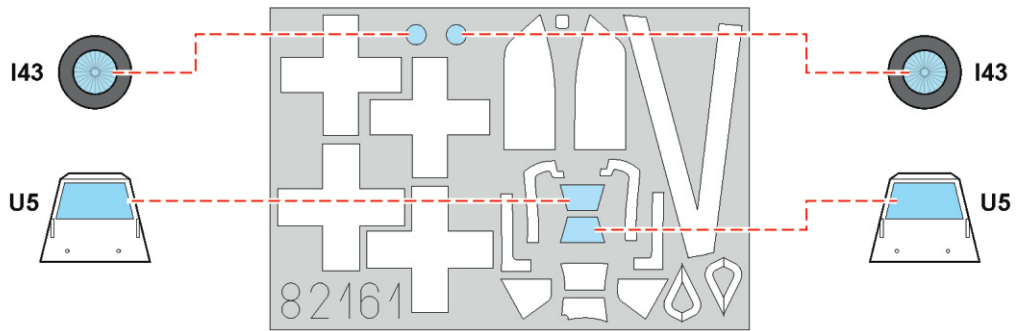

A Bf 109G-10/U4, II./JG 52, Brno, Protektorat Böhmen und Mähren, April 1945

After II./JG 51 was disbanded on April 5th, 1945, at Fels am Wagram, together with its pilots the equipment was relocated as well. One of the one-o-nines which were transferred from II./JG 51, is the aircraft named Rosemarie. The original aircraft operator can be determined thanks to the overpainted marking which location was exclusively used by II./JG 51.

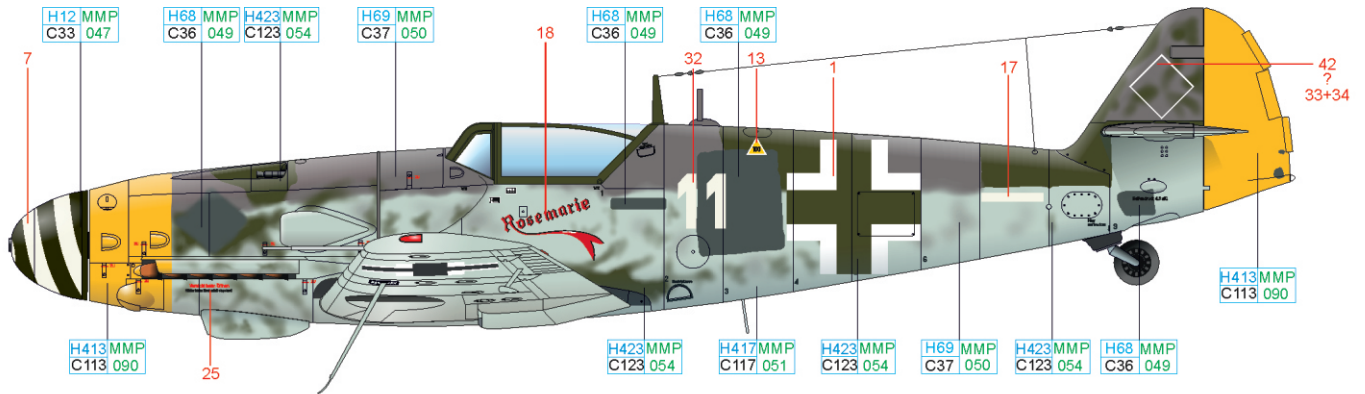

ČESKOU VERZI TEXTU NALEZNETE NA
www.eduard.cz
POD KATALOGOVÝM ČÍSLEM 82161

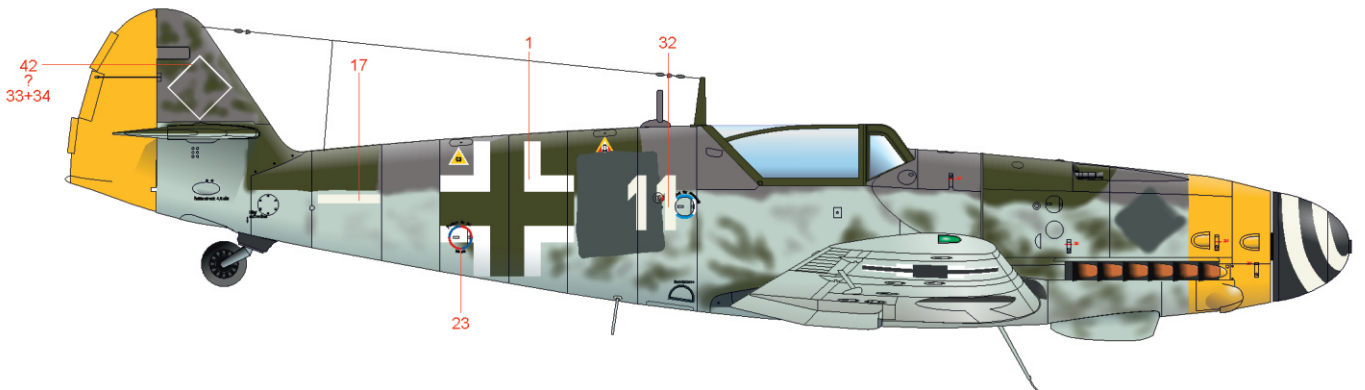
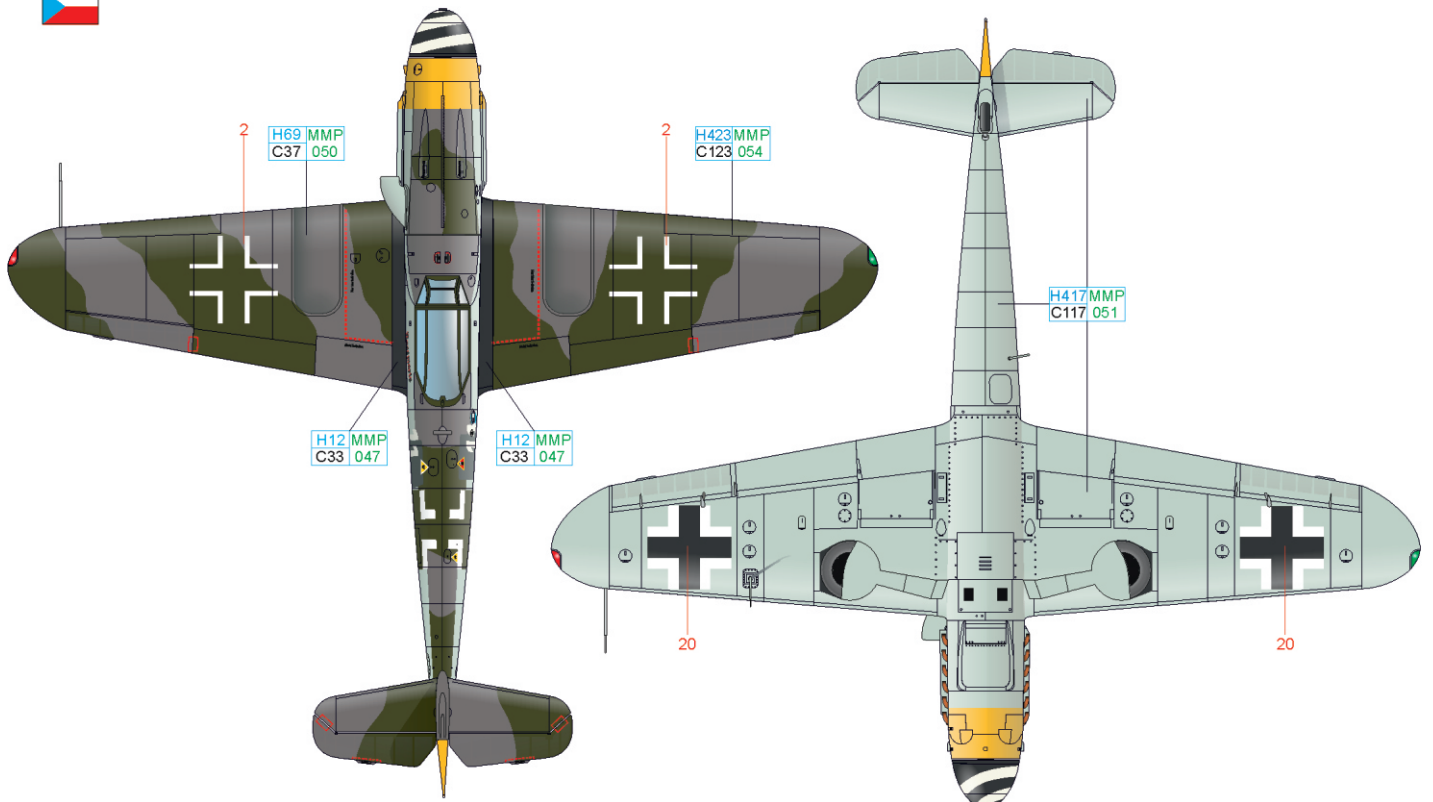

RLM 04	H413 MMP C113 090	BLACK	H12 MMP C33 047
RLM 83	H423 MMP C123 054	RLM 75	H69 MMP C37 050
		RLM 76	H417 MMP C117 051
		RLM 74	H68 MMP C36 049

B Bf 109G-10/U4, W. Nr. 612769, 101. vadászszereg, Neubiberg airfield, Germany, May 8th, 1945

In the end of March 1945, the remaining Hungarian units concentrated at Tulln airport in Austria from where they flew sorties to the areas of Vienna and Brno. After the front approached Tulln, on April 5th, 1945, they relocated to Raffelding airport, from where they continued in the air support of the land forces in the vicinity of Vienna. At the end of war, the Hungarian airmen, same as their German comrades-in-arms, better surrendered to the American Army therefore the 101. vadászszereg pilots flew over to the Bavarian Neubiberg with the remaining aircraft. Airframes manufactured in Diana plant were camouflaged in the same camouflage colors as the airframes from Wiener Neustadt plant. From the photographs of "yellow 12" is obvious that the Hungarian national markings were spray-painted directly on the factory camouflage, the German markings had not been applied at all. Part of the wing under surfaces remained in the natural metal color.

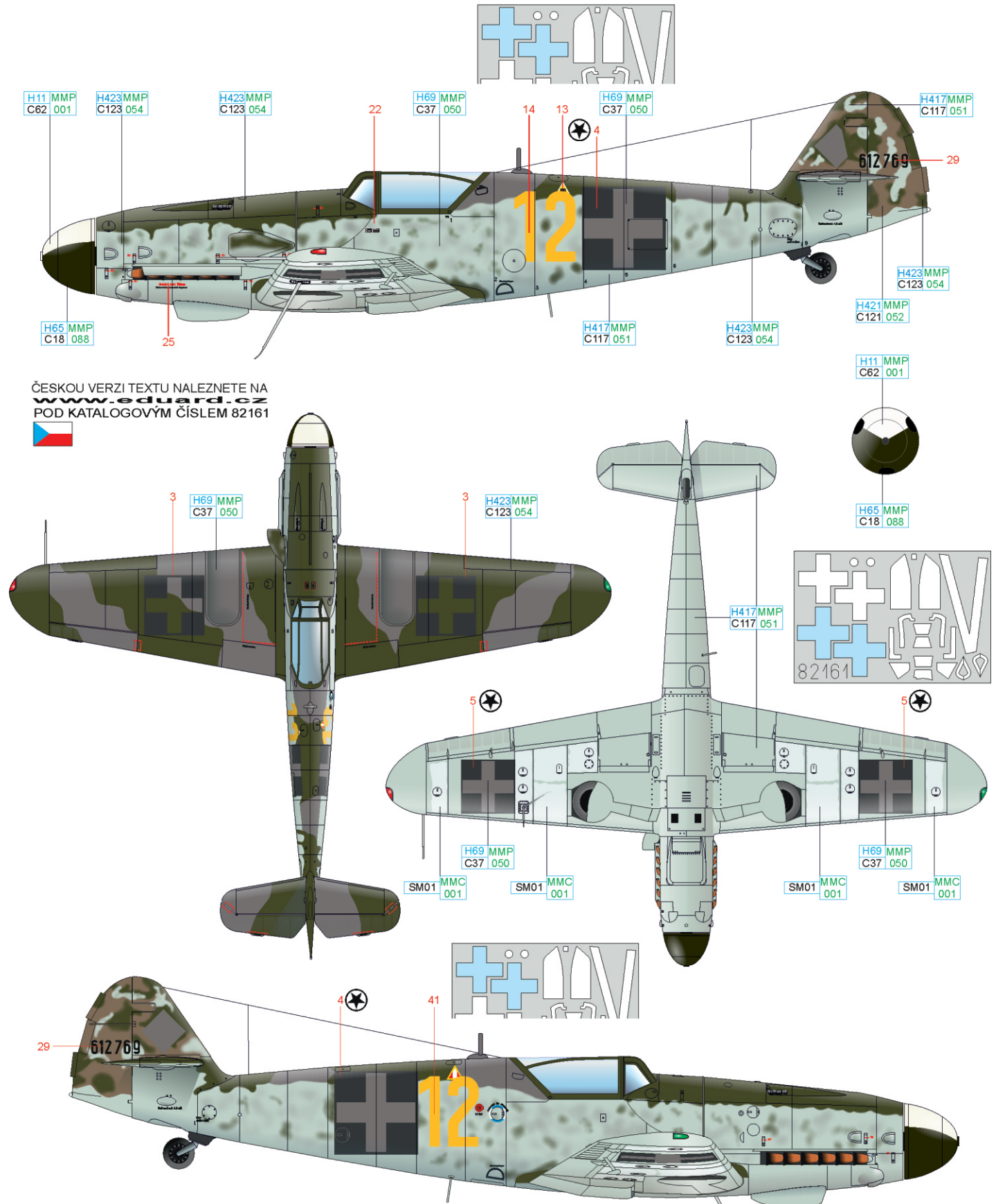

RLM 70	H65 MMP C18 088	WHITE	H11 MMP C62 001	RLM 81	H421 MMP C121 052
RLM 83	H423 MMP C123 054	RLM 75	H69 MMP C37 050	RLM 76	H417 MMP C117 051
		ALUMINIUM	SM01	MMC	001

C Bf 109G-10/U4, W. Nr. 611048, II./JG 52, Neubiberg airfield, Germany, May 8th, 1945

In the middle of April 1945 II./JG 52 relocated from Fels am Wagram airport to Hosching airport from where she flew the missions to support the German units as well as against the Soviet offensive during the battle of Brno, as well as fighter sorties against the American units over Austria and Southern Czech Lands. In the beginning of May, the relocation to Zeltweg followed and from here, on May 8th, 1945, all airworthy planes took off for Bavarian Neubiberg, where the pilots were captured the American Army. Camouflage of this airframe, spray-painted in RLM 75/83 colors on the upper surfaces and RLM 76 on the lower surfaces is complimented by the Luftflotte 4 recognition marking introduced on March 7th, 1945, in the form of yellow painted nose and rudder. Before the assignment to II./JG 52 the aircraft had served with another unit, its original marking was overpainted in the camouflage color. The rudder features 7 kill markings.

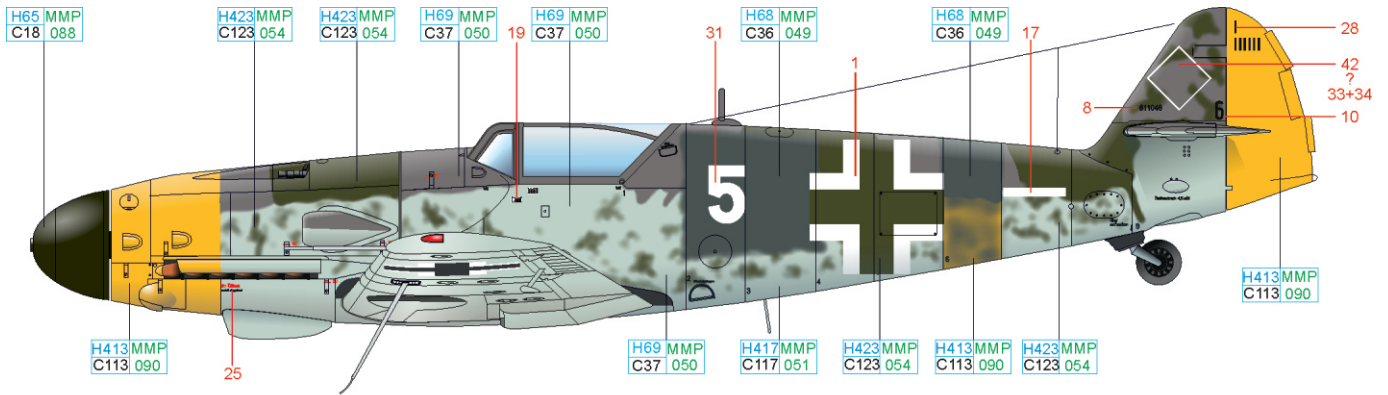

ČESKOU VERZI TEXTU NALEZNETE NA www.eduard.cz POD KATALOGOVÝM ČÍSLEM 82161

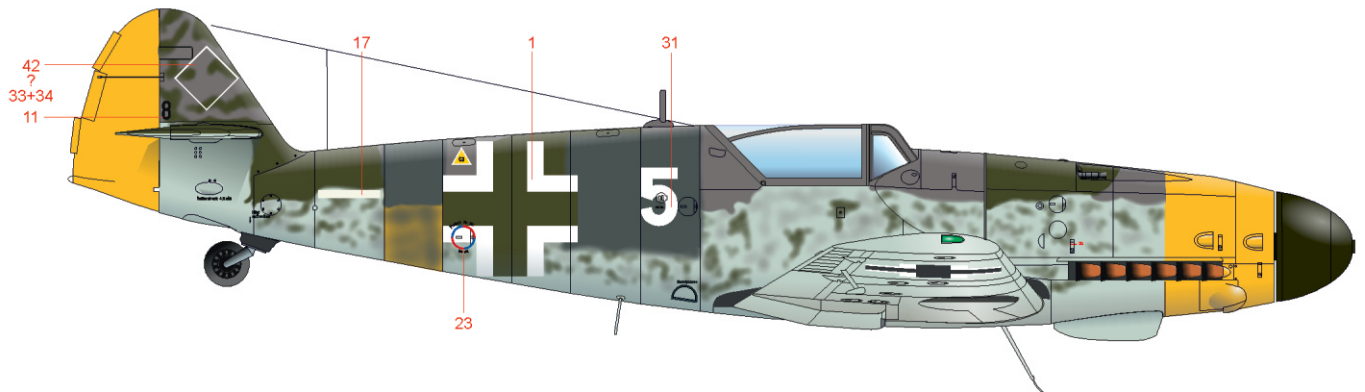
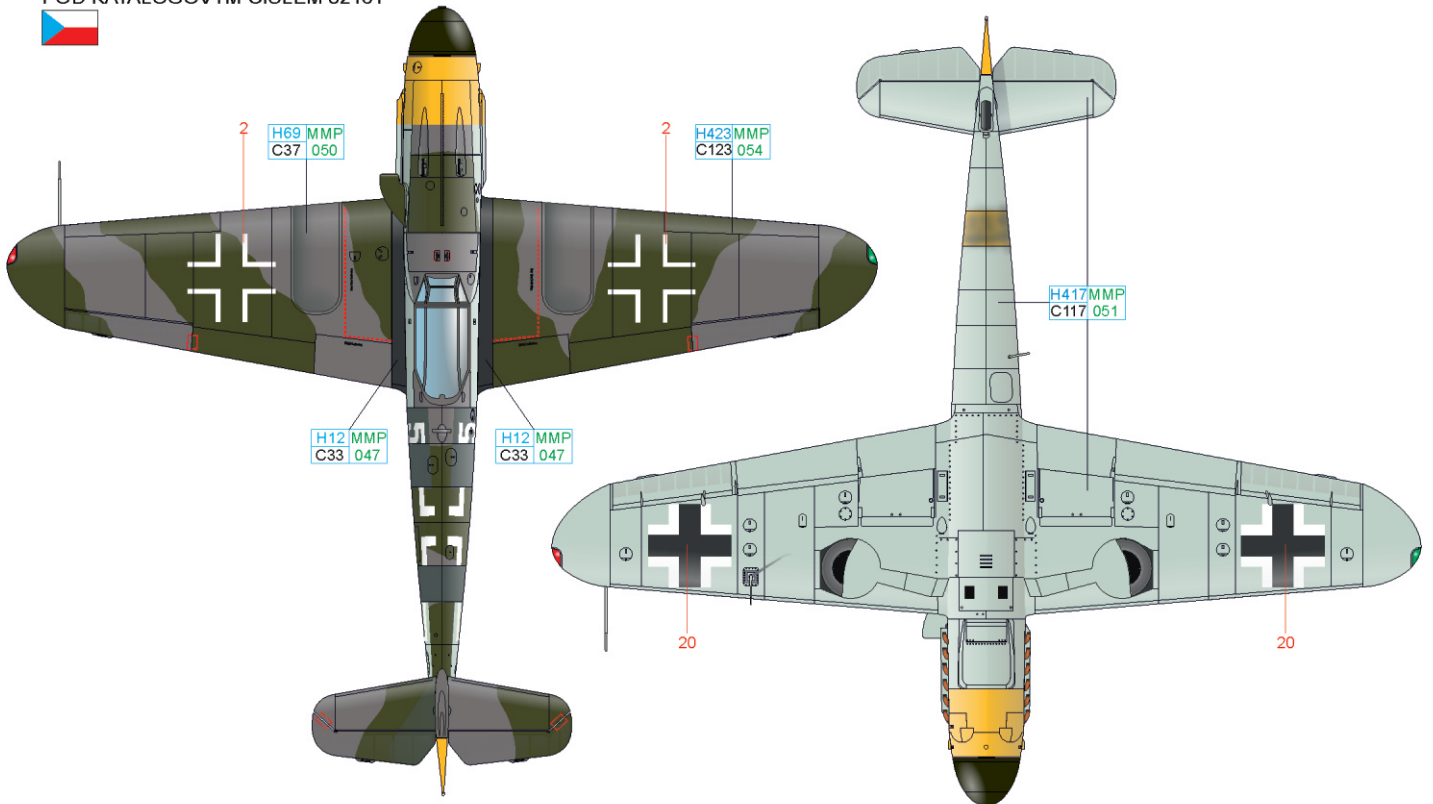

RLM 70	H65 MMP C18 088	RLM 04	H413 MMP C113 090	BLACK	H12 MMP C33 047
RLM 83	H423 MMP C123 054	RLM 75	H69 MMP C37 050	RLM 76	H417 MMP C117 051
				RLM 74	H68 MMP C36 049

D Bf 109G-10/U4, Jasta 5 der ROA, Nemecky Brod, Protektorat Böhmen und Mähren, May 1945

In the beginning of March 1945, Jasta 5 of the Russian Liberation Army led by Major S. T. Bychkov was located at Deutsch Brod (nowadays Havlickuv Brod) airbase. Together with the Nachtschlachtstaffel 8 of the ROA, equipped with Ju 87D-5 dive bombers, Jasta 5 participated in the German units' battles of retreat during the fight for Brno in April 1945. Some of the aircraft used by this unit were found abandoned at the Deutsch Brod airport. The airframe sporting the camouflage typical for the WNF plant production carries the ROA aircraft marking on the vertical tail surface in the form of St. Andrew's Cross.

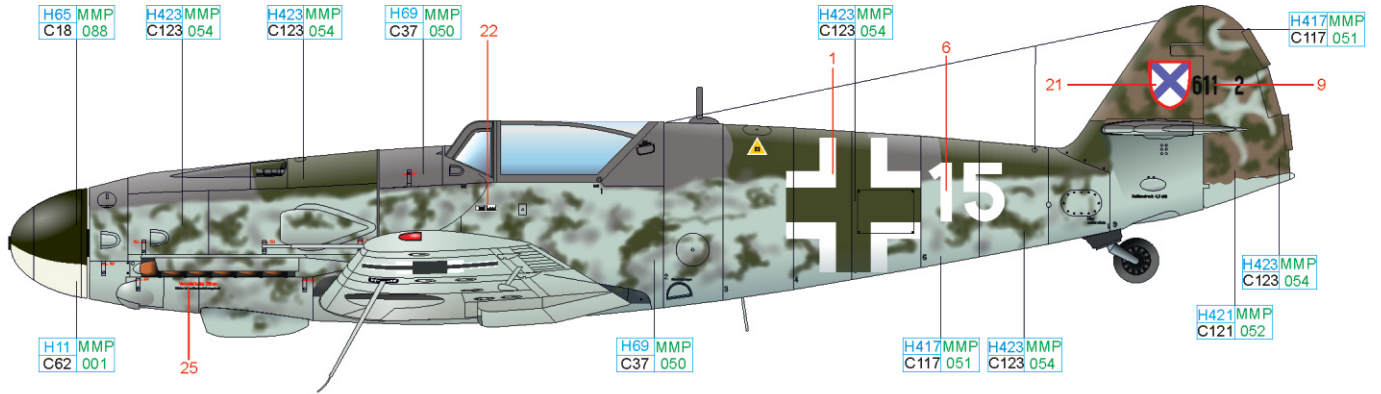

ČESKOU VERZI TEXTU NALEZNETE NA www.eduard.cz POD KATALOGOVÝM ČÍSLEM 82161

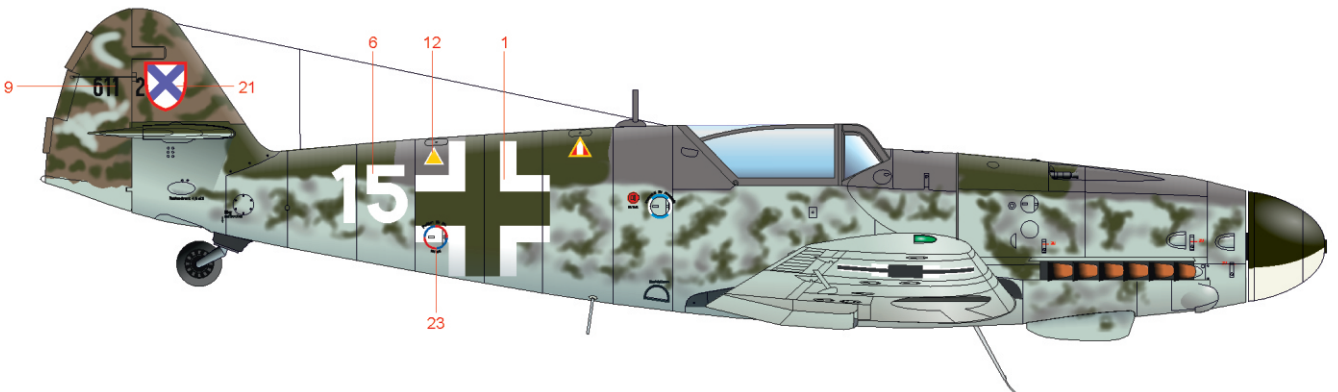
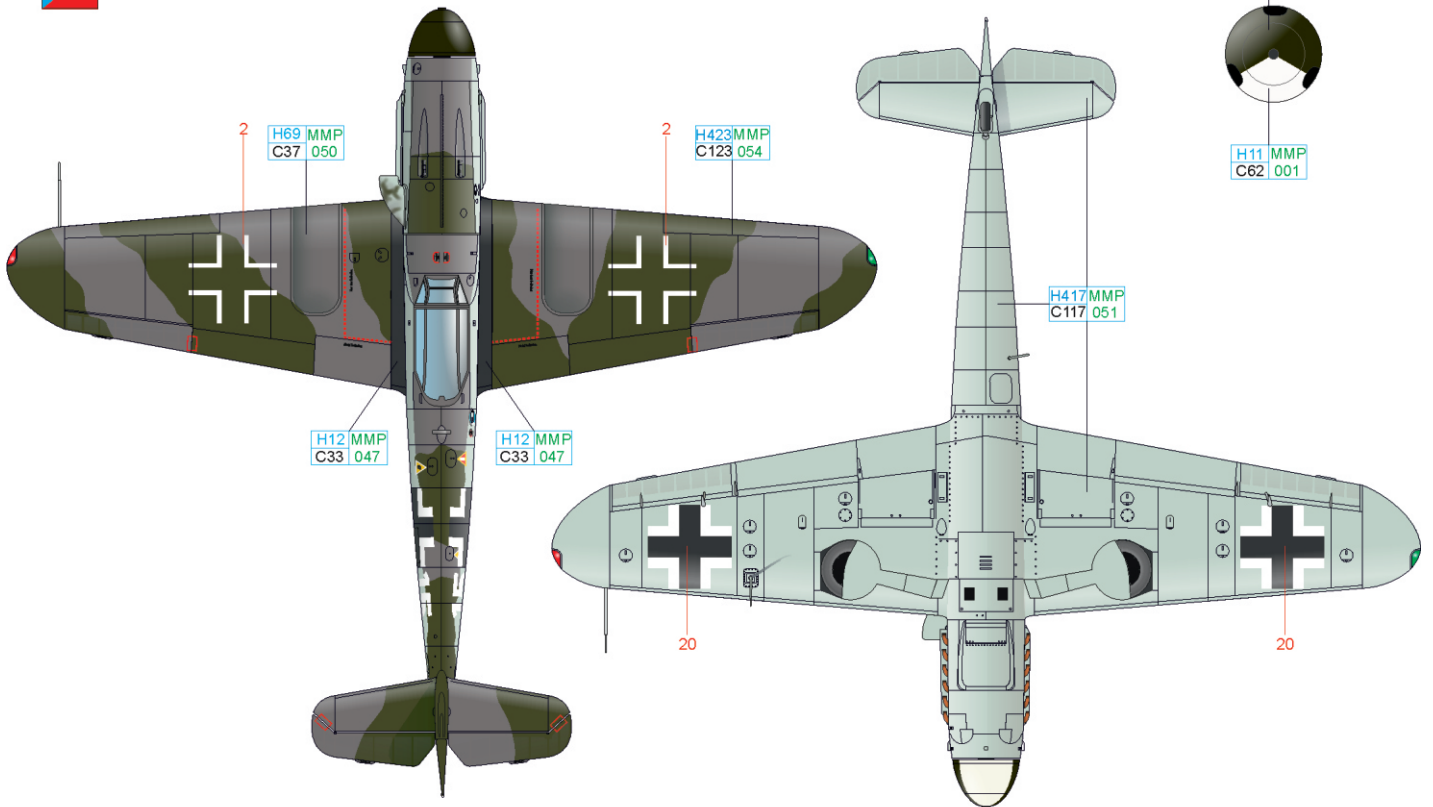

RLM 70	H65 MMP C18 088	WHITE	H11 MMP C62 001	RLM 81	H421 MMP C121 052
RLM 83	H423 MMP C123 054	RLM 75	H69 MMP C37 050	RLM 76	H417 MMP C117 051
		BLACK	H12 MMP C33 047		

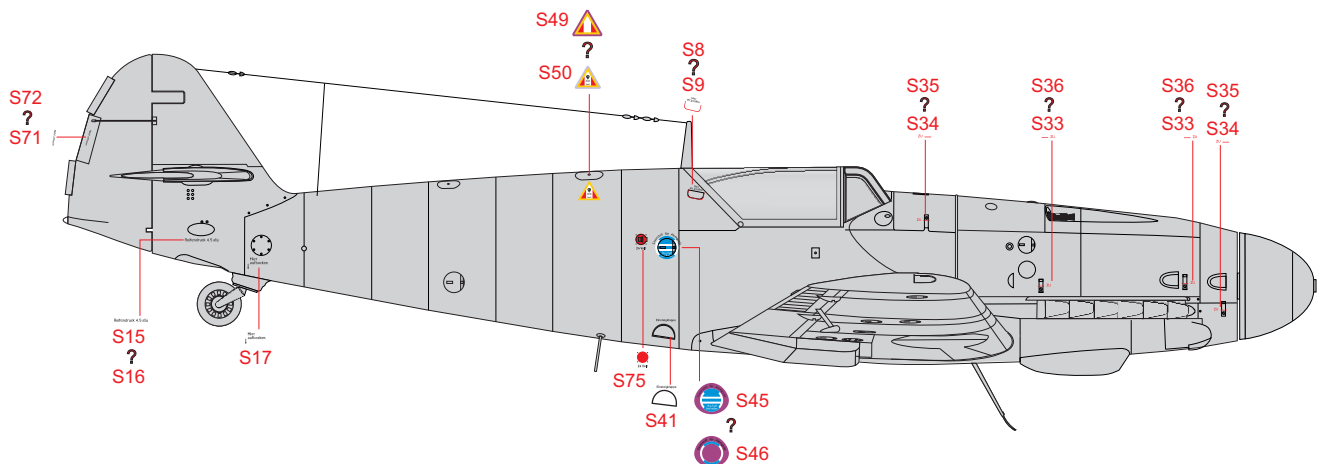
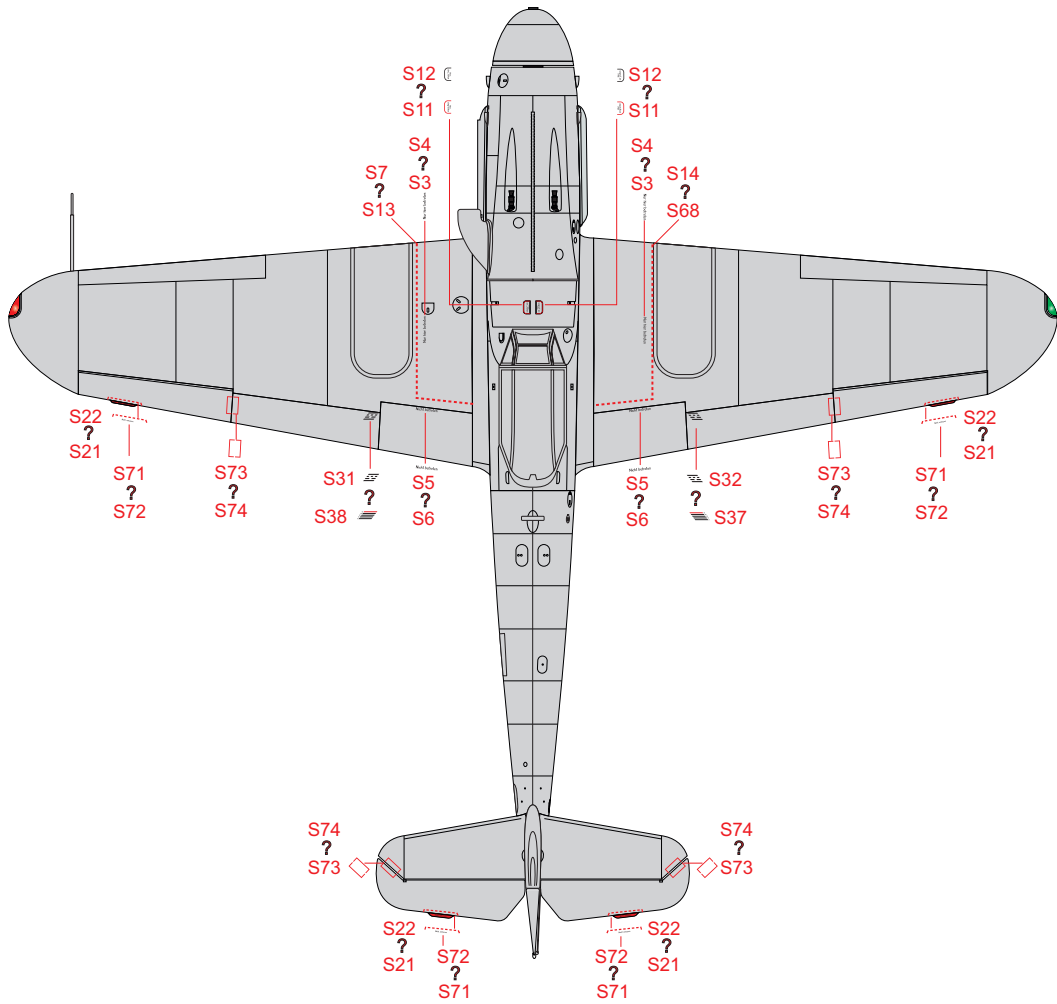
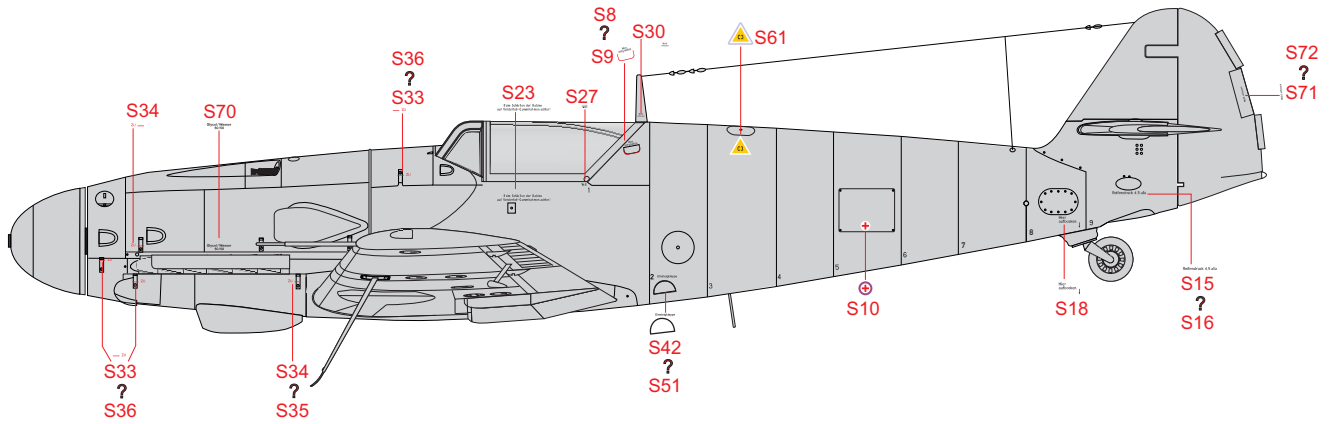

Bf 109G-10 WNF/Diana

1/48

#82161
ProfiPACK
 edition

eduard

RELATED PRODUCTS:

- 49094 Bf 109G seatbelts SUPERFABRIC 1/48 (PE-set)
- 49095 Seatbelts Luftwaffe WWII fighters STEEL 1/48 (PE-Set)
- 644004 Bf 109G-10 Löök 1/48 (Brassin)
- 648158 Bf 109G-10 wheels 1/48 (Brassin)
- 648247 Bf 109G exhaust stacks 1/48 (Brassin)
- 648265 Bf 109G external fuel tanks 1/48 (Brassin)
- 648309 Bf 109G undercarriage legs BRONZE 1/48 (Brassin)
- 648422 Bf 109G-10 cockpit 1/48 (Brassin)
- 648441 Bf 109G-10 engine 1/48 (Brassin)
- EX609 Bf 109G-10 TFace 1/48 (Mask)

