

Bf 109G-2

eduard

1/48 Scale Plastic Model Kit

ProfiPACK
edition



item No. 82165

No other aircraft is so intimately connected with rise and fall of the German Luftwaffe during the WWII like the Messerschmitt Bf 109. It became the true workhorse of the war...

The evolution of this aircraft outlived the era in which it was conceptualized. The Bf 109s bore the brunt of Luftwaffe duties from the opening battles of Nazi Germany through to her final downfall.

As progressive as possible

The history of the aircraft begins during 1934-35, when the Reich Ministry of Aviation formulated a requirement for the development of a single-engined monoplane fighter. Proposals were submitted by Arado, Heinkel, Focke-Wulf and Bayerische Flugzeugwerke. The design bureau of the last-mentioned company was led by its technical director Willy Messerschmitt, who was riding a wave of popularity based on the success of his liaison aircraft, the Bf 108. Messerschmitt's goal was to conceive of an aircraft with the best possible performance for the specified weight, size, and aerodynamic qualities. Over the subsequent months, several prototypes were built that served first and foremost in development flights and further modifications. The aircraft was relatively small, and compared to the prevailing trends of the time, full of revolutionary features such as low wing design, retractable landing gear, wing with a thin airfoil, wing slats, landing flaps, weapons firing through the propeller hub, and so on. Even the enclosed cockpit and the method of the airframe design were not very common just four years prior to the beginning of the Second World War. At its conception, the Bf 109 was a very promising asset despite some powerplant troubles. These were solved by the introduction of the DB 601. This engine, together with its development DB 605 variant, is umbilically connected to the success of the Bf 109. These two-row, twelve-cylinder inverted V engines powered several tenths of thousands of 109s in over 25 versions and variants.

From Spanish War to the defence of the Reich

The first combat use of Bf 109 occurred during Spanish Civil War, where three developmental Bf 109s were deployed in December 1936. The main reason of revealing the modern fighter to the world was quite down-to-earth: To validate the aircraft's abilities in modern aerial combat. Shortly thereafter, production aircraft in the form of the Bf 109B-1 began to reach 2.J/88, the Legion Condor. The desire of Germany to demonstrate its aerial prowess to potential foes was advanced further in international sport meets. The triumphs attained in Zurich in the summer of 1937 were complemented several months later by grabbing the speed record of 610.95 kph. In very short order, the progressive developments represented by the C, D and E versions appeared. Despite this, the delivery of the types to combat units did not sustain a rate that was desired by military brass. Even by August 1938 the Bf 109 accounted for less than half of the 643 front line fighters in service. The later months saw an increase in these rates. By the time of the invasion of Poland (which saw the participation of only some little more than 200 aircraft) the Luftwaffe possessed the best fighter

produced in continental Europe. With both a qualitative and quantitative advantage, the fighter wing of the Luftwaffe entered the Polish campaign, the first defence of the Fatherland, Blitzkrieg against the West, and the Battle for France. With one foot in the door that was the English Channel, the Luftwaffe embarked on the attacks on Britain in the summer months of 1940. Here, the first weakness of the Bf 109 emerged: The inability to carry drop tanks that would have enabled the type to effectively escort bombers to England. This was one of the factors responsible for the defeat of the Luftwaffe in the Battle of Britain. Experiences gained in 1940 led to the development of the F version prior to the spring of 1941. The elegance of the Bf 109 crested with the "Friedrich". Following a largely defensive stance over the Channel and northern France, the Bf 109F took on a more offensive role in Operation Barbarossa in the east, and in northern Africa. In later duties with the 'Jagdarmee' during the second phase of the war in the east, and in the 'Defense of the Reich' from 1943 to 1945, the Bf 109 served in the form of the G version, followed by the K. Even it was clear the development of the Bf 109 was depleted by the end of the war the aircraft was still able to keep pace with the foes that it encountered. Besides its primary purpose as a fighter, the Bf 109 also appeared as a fighter-bomber, reconnaissance platform, night fighter, trainer and rammjäger.

Postwar service

The disappearance of the Bf 109 from the skies over Europe was not spelled out by the end of the war. Several examples stayed in Swiss service up to 1949 and many flew in the air force of Czechoslovakia in both original form with a DB 605 powerplant and as an aircraft built out of necessity with surplus Jumo 211s. The latter type also served as the first fighter to fight for the independence of the newly formed state of Israel. Finland retired the type at 1954, and Spain did not retire its HA-1109-1112, re-engined Bf 109s, until 1967. The legendary low-wing fighter of Professor Willy Messerschmitt survived the state that developed it.

The kit: Bf 109G-2

The Bf 109G series (Gustav) was direct follow-on of the Bf 109F. The main difference was the more powerful DB 605 engine, which was the direct development of the DB 601 as well. The main difference, bigger displacement of the engine, was achieved by bored-out cylinders (by 4 mm) enlarging the total displacement from 33,9 l to 35,7 l. Another power increasing change was higher compression ratio. The maximum take-off power rose to 1,450 hp (1,080 kW) from the 1,350 hp (993 kW) of DB 601E. The G-2 was the first unpressurised serial sub-variant of the G series. It retained the retractable tail wheel from the F series as well as the armament scheme with one MG 151/20 cannon and two 7,92 mm machine guns MG17. There were some 1590 of Bf 109G-2s produced.

ATTENTION



UPOZORNĚNÍ



ACHTUNG



ATTENTION



注意



Carefully read instruction sheet before assembling. When you use glue or paint, do not use near open flame and use in well ventilated room. Keep out of reach of small children. Children must not be allowed to suck any part, or pull vinyl bag over the head.



Před započítím stavby si pečlivě prostudujte stavební návod. Při používání barev a lepidel pracujte v dobře větrané místnosti. Lepidla ani barvy nepoužívejte v blízkosti otevřeného ohně. Model není určen malým dětem, mohlo by dojít k požití drobných dílů.

INSTRUCTION SIGNS * INSTR. SYMBOLS * INSTRUKTION SINNBILDEN * SYMBOLES * 記号の説明

OPTIONAL
VOLBABEND
OHNOUTSAND
BROUSITOPEN HOLE
VYVRTAT OTVORSYMETRICAL ASSEMBLY
SYMETRICKÁ MONTÁŽREMOVE
ODŘÍZNOUTREVERSE SIDE
OTOČITAPPLY EDUARD MASK
AND PAINT
POUŽIT EDUARD MASK
NABARVIT

PARTS



DÍLY



TEILE



PIÈCES



部品

PLASTIC PARTS

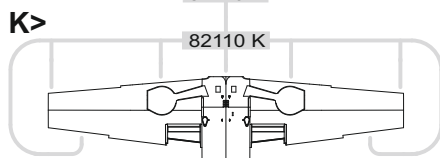
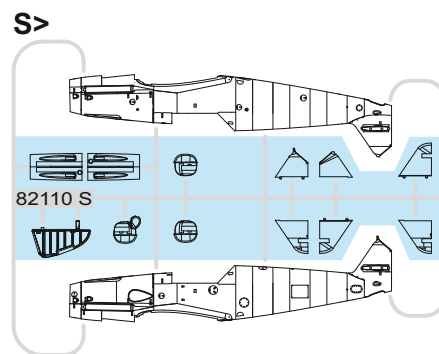
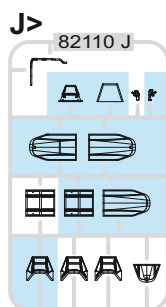
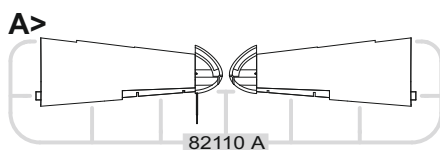
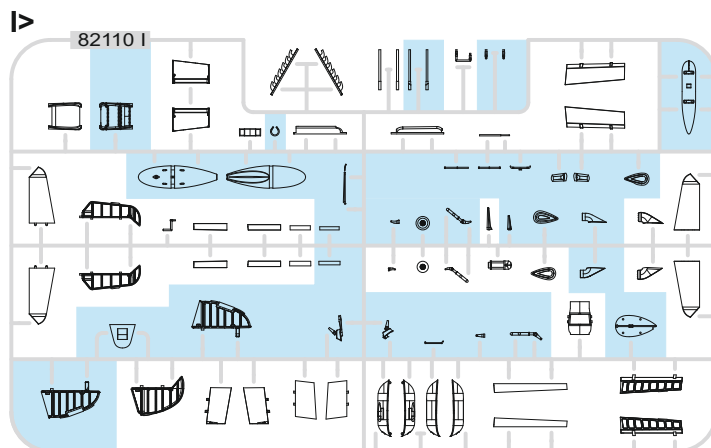
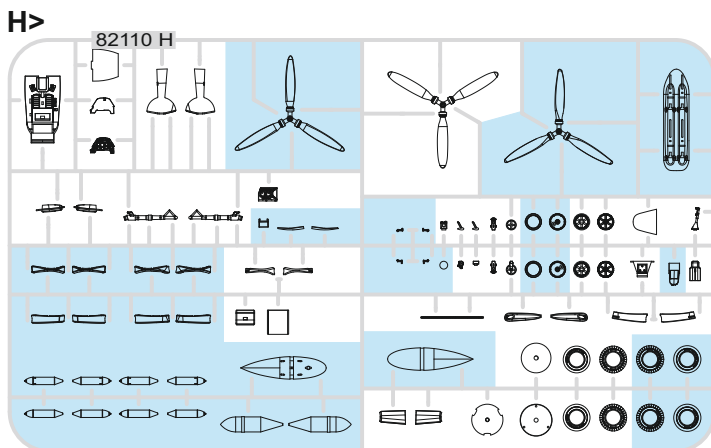
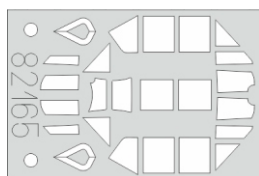
eduard
MASK

PE - PHOTO ETCHED DETAIL PARTS

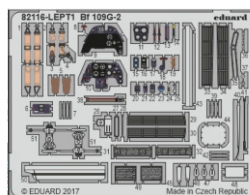

-Parts not for use. -Teile werden nicht verwendet. -Pièces à ne pas utiliser. -Tyto díly nepoužívejte při stavbě. - 使用しない部品

COLOURS



BARVY



FARBEN



PEINTURE



色

GSI Creos (GUNZE)		MISSION MODELS	
AQUEOUS	Mr.COLOR	PAINTS	
H2	C2	MMP-047	BLACK
H11	C62	MMP-001	FLAT WHITE
H12	C33	MMP-047	FLAT BLACK
H47	C41	MMP-012	RED BROWN
H64	C17	MMP-087	RLM71 DARK GREEN
H65	C18	MMP-088	RLM70 BLACK GREEN
H66	C119	MMP-119	RLM79 SAND YELLOW
H68	C36	MMP-049	RLM74 DARK GRAY
H69	C37	MMP-050	RLM75 GRAY
H70	C60	MMP-056	RLM02 GRAY
H77	C137	MMP-040	TIRE BLACK
H90	C47		CLEAR RED
H94	C138		CLEAR GREEN

GSI Creos (GUNZE)		MISSION MODELS	
AQUEOUS	Mr.COLOR	PAINTS	
H413	C113	MMP-090	RLM04 YELLOW
H414	C114	MMP-003	RLM23 RED
H416	C116	MMP-089	RLM66 BLACK GRAY
H417	C117	MMP-051	RLM76 LIGHT BLUE
H418	C118	MMP-055	RLM78 LIGHT BLUE
H420	C120	MMP-120	RLM80 OLIVE GREEN
Mr.METAL COLOR		METALLICS	
MC213		MMM-006	STEEL
MC214		MMM-001	DARK IRON
Mr.COLOR SUPER METALLIC		METALLICS	
SM201		MMC-001	SUPER FINE SILVER
Mr.COLOR GX		METALLICS	
GX05			SUSIE BLUE

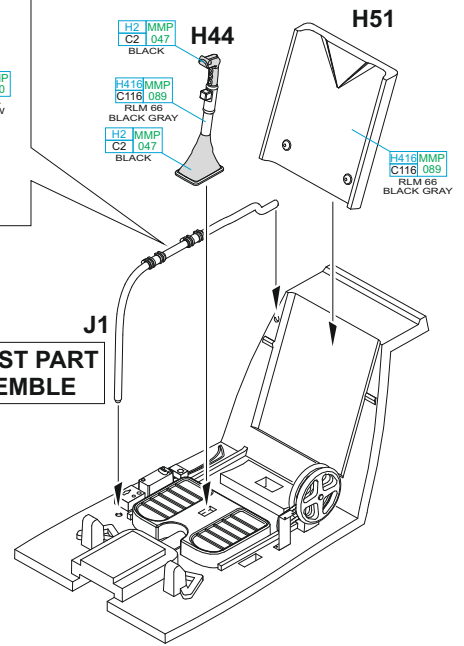
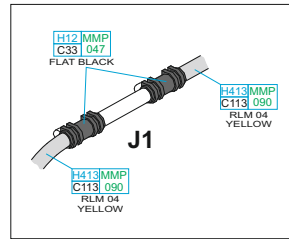
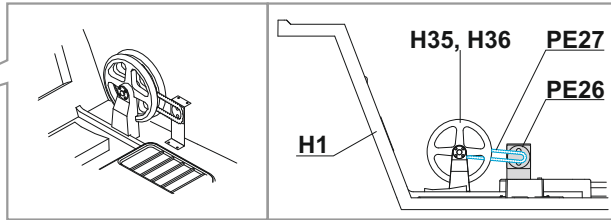
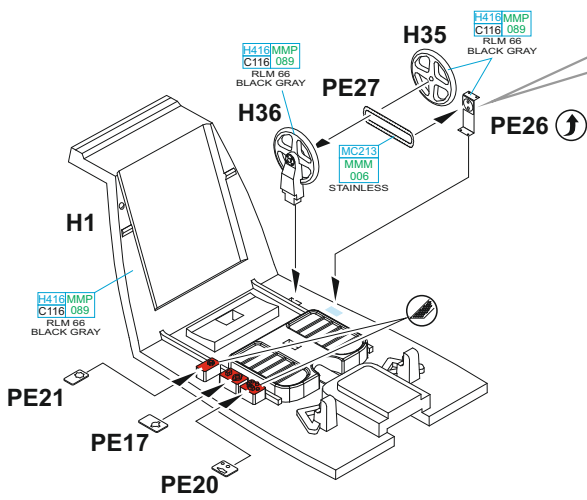

THE LATEST PART TO ASSEMBLE

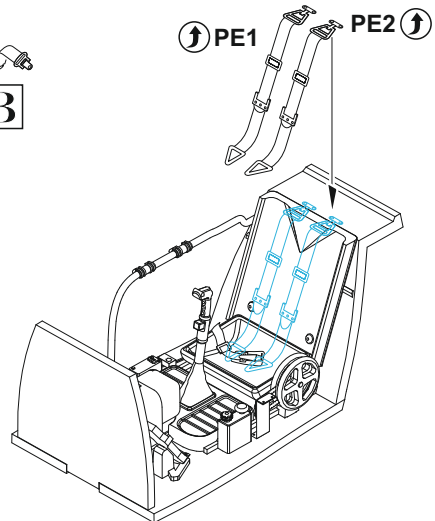
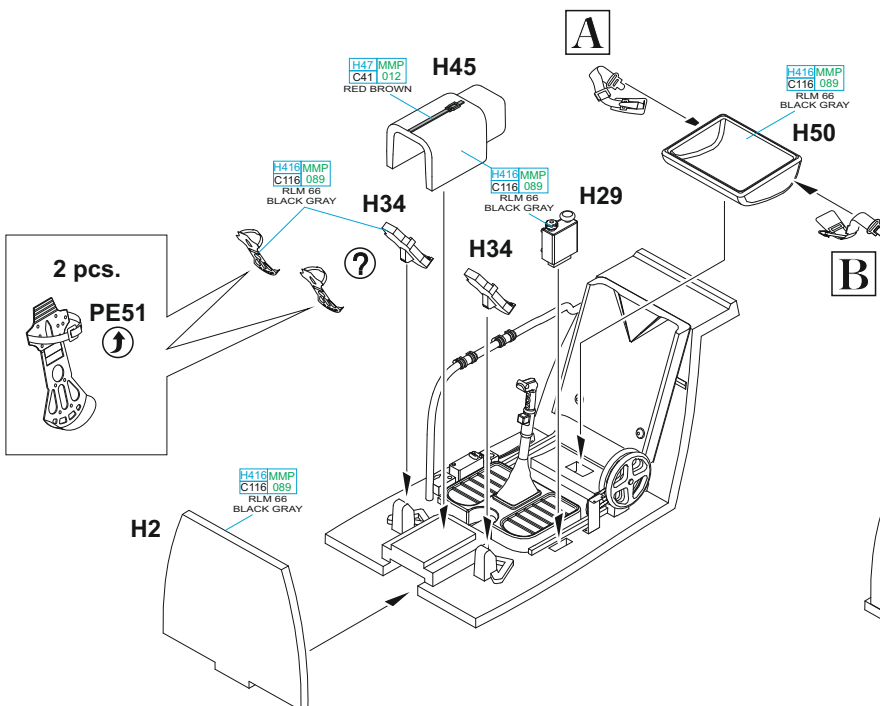
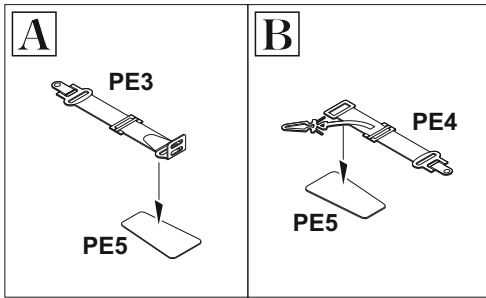

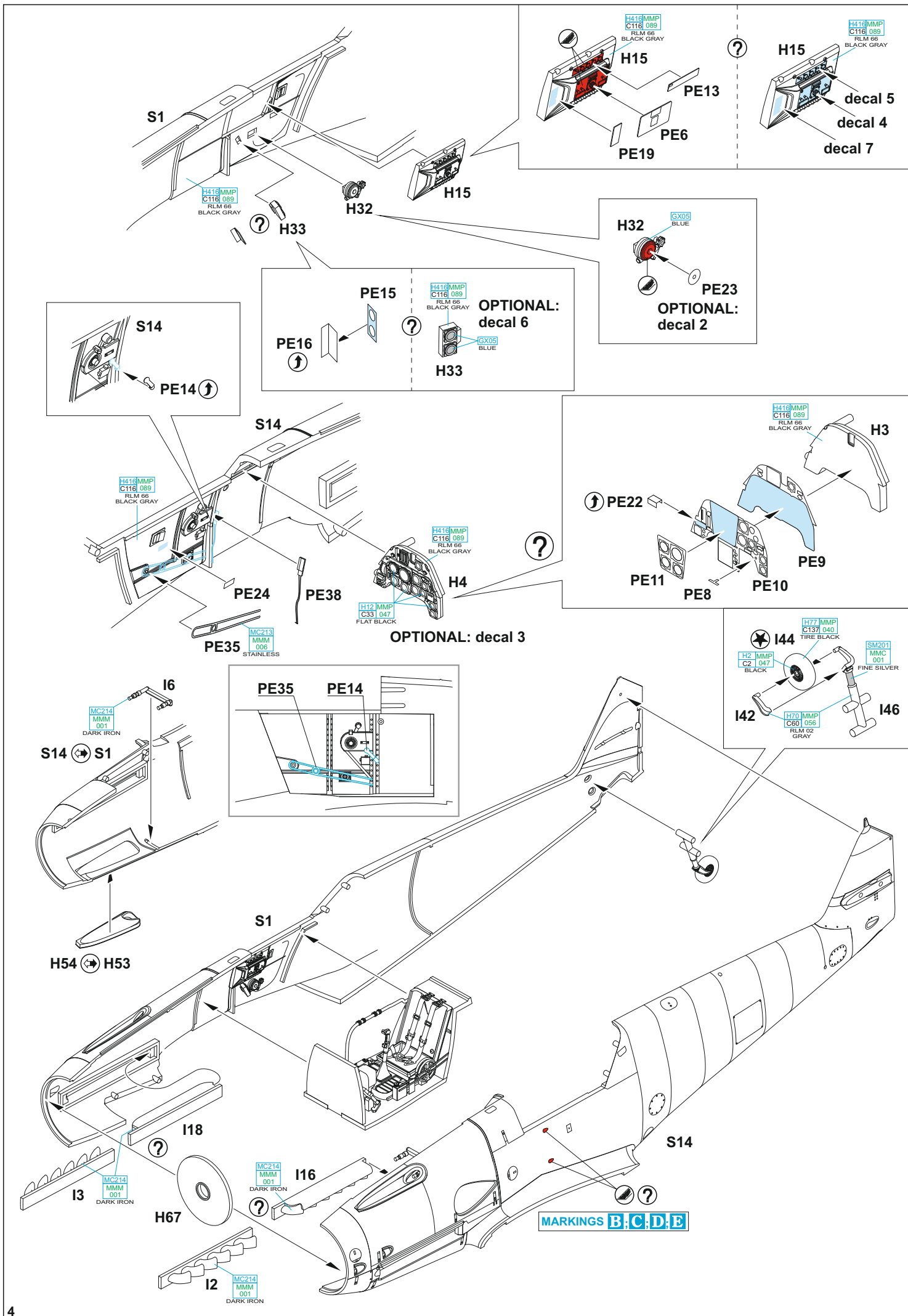

MARKING A ONLY

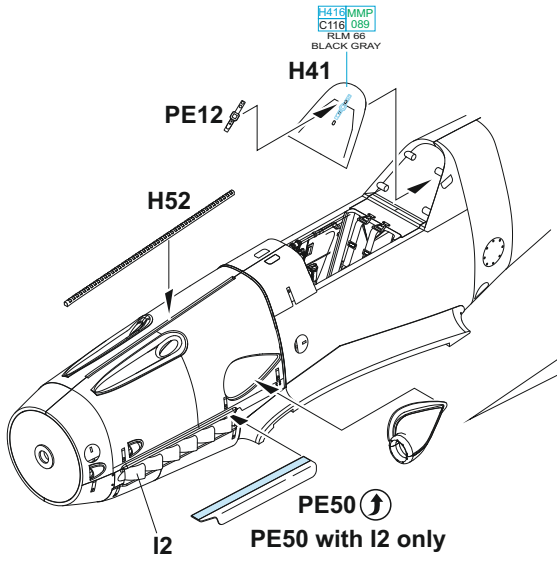

H41 MMP
C116 099
RLM 66
BLACK GRAY

↑ PE49

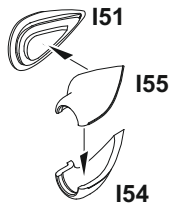
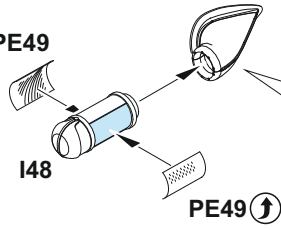

MARKING A ONLY

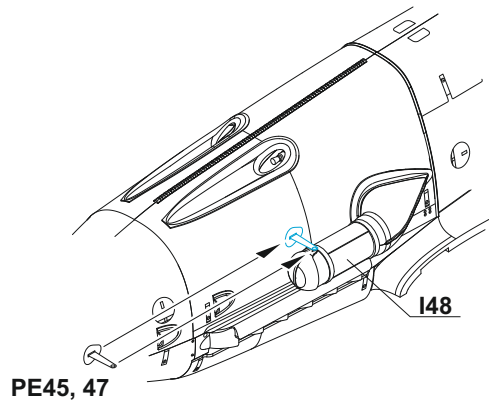
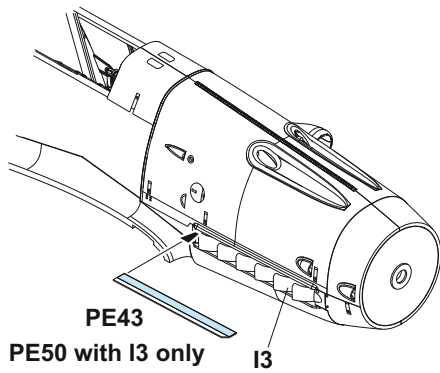

PE46, 47

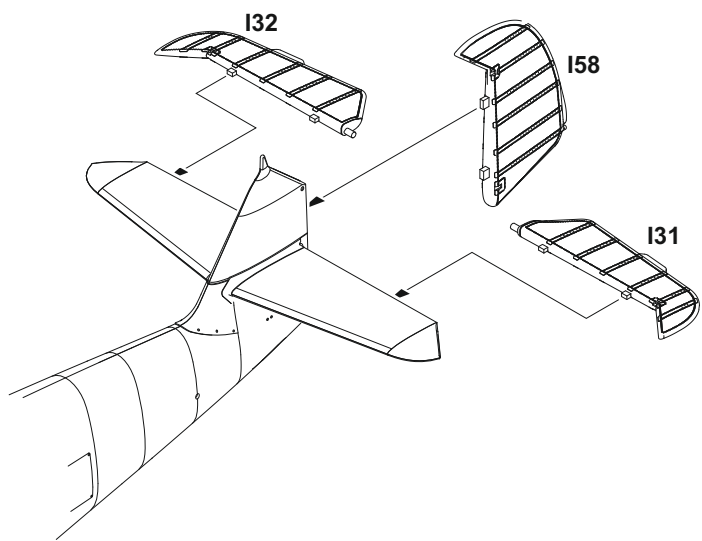
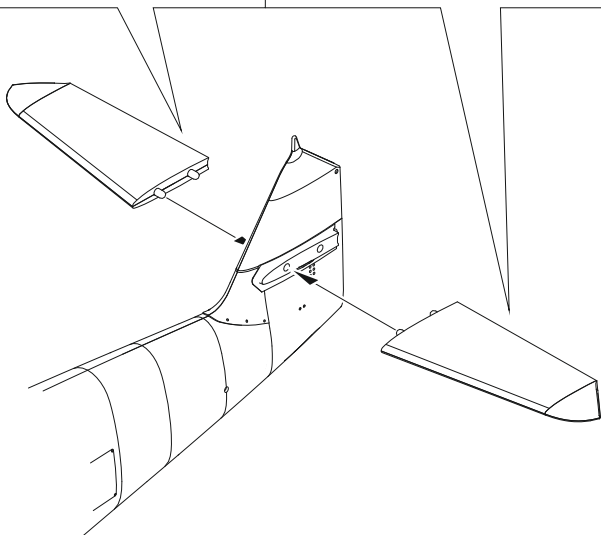
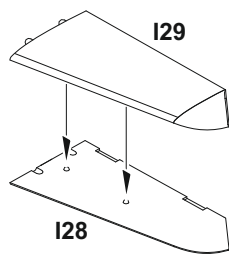
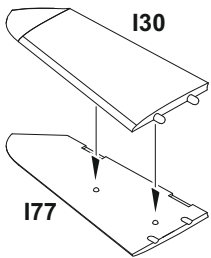
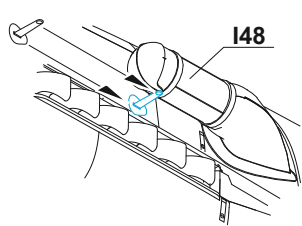

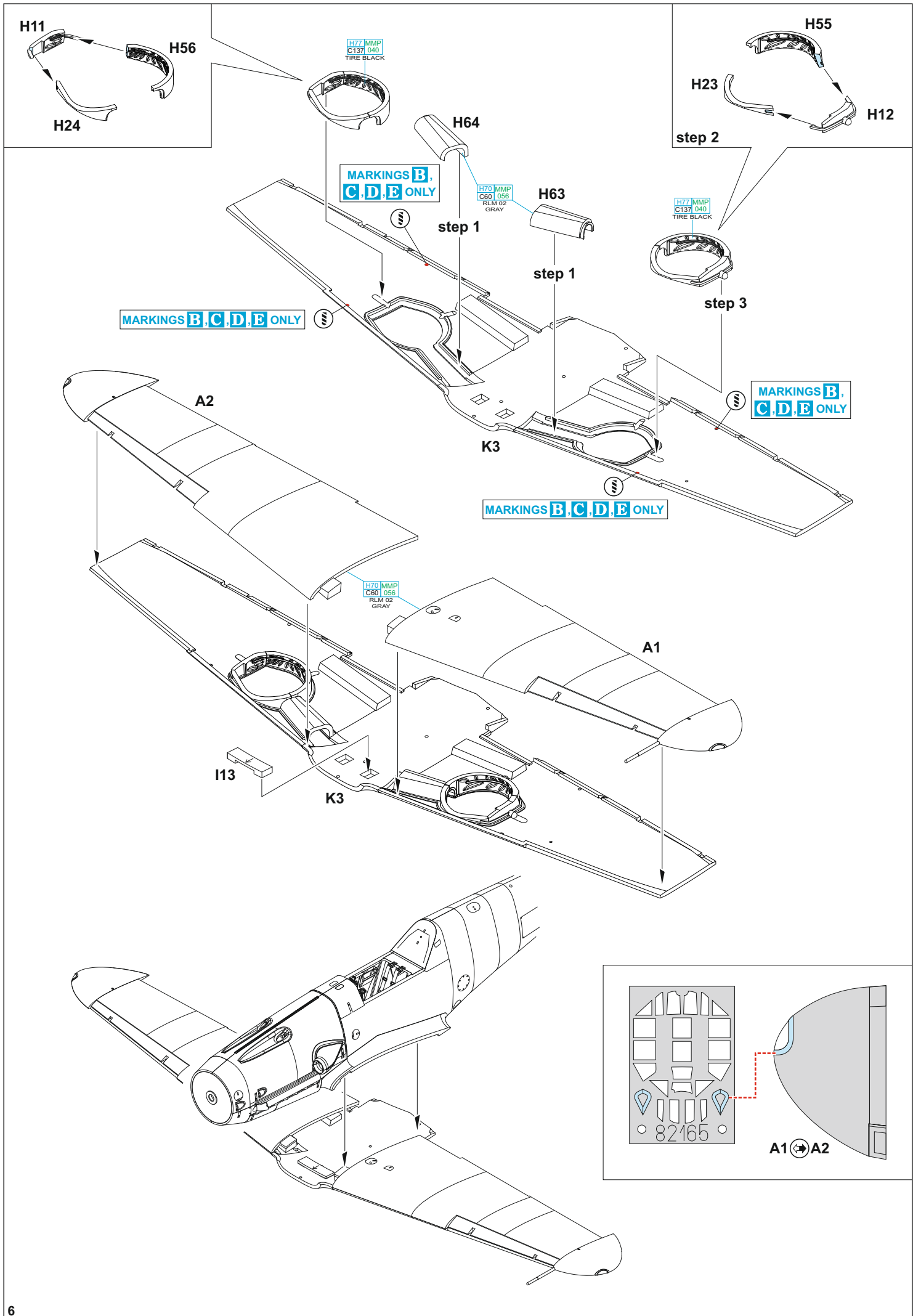

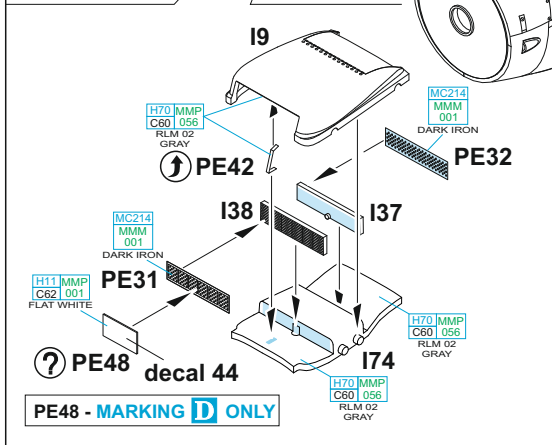
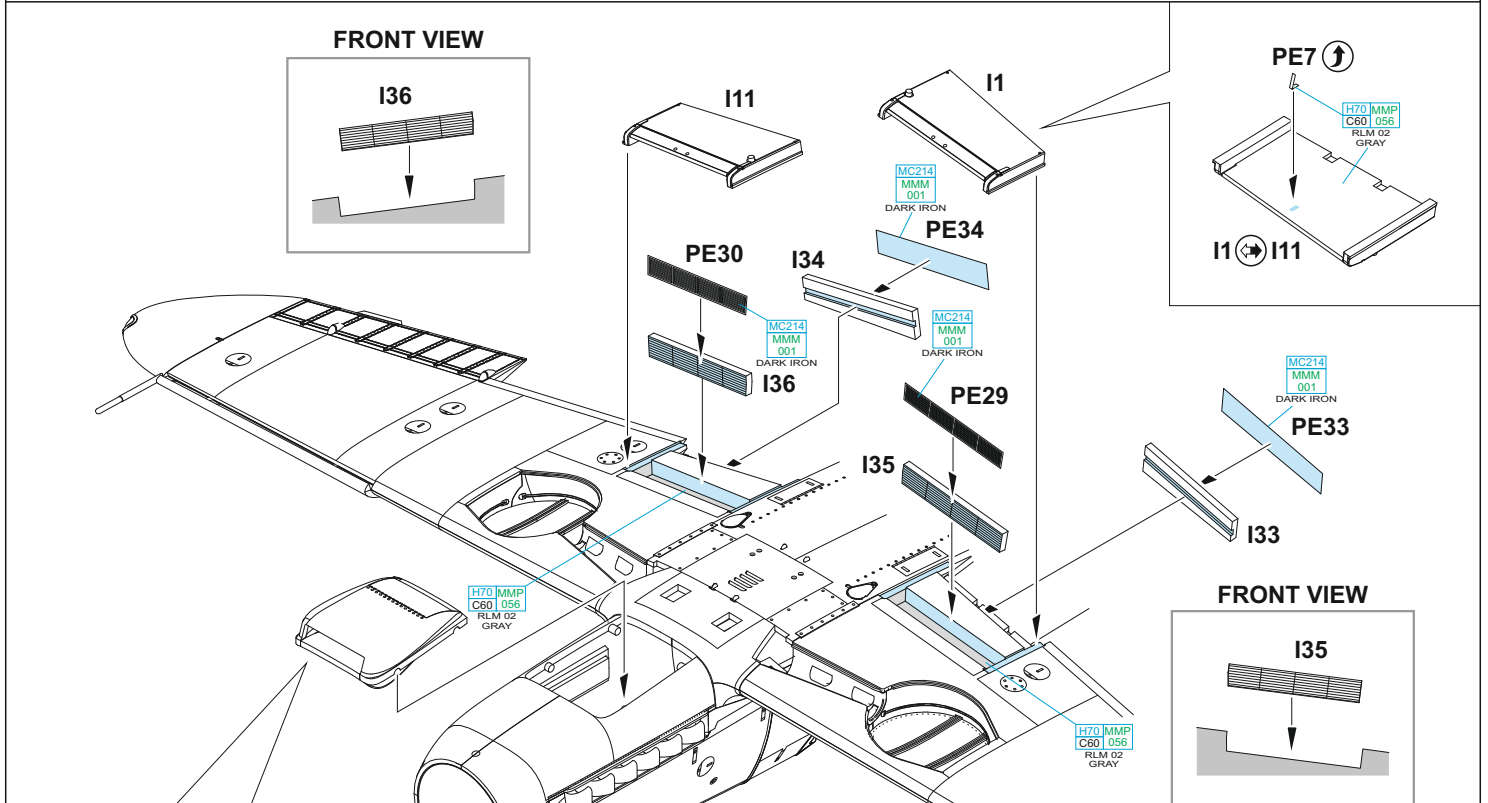
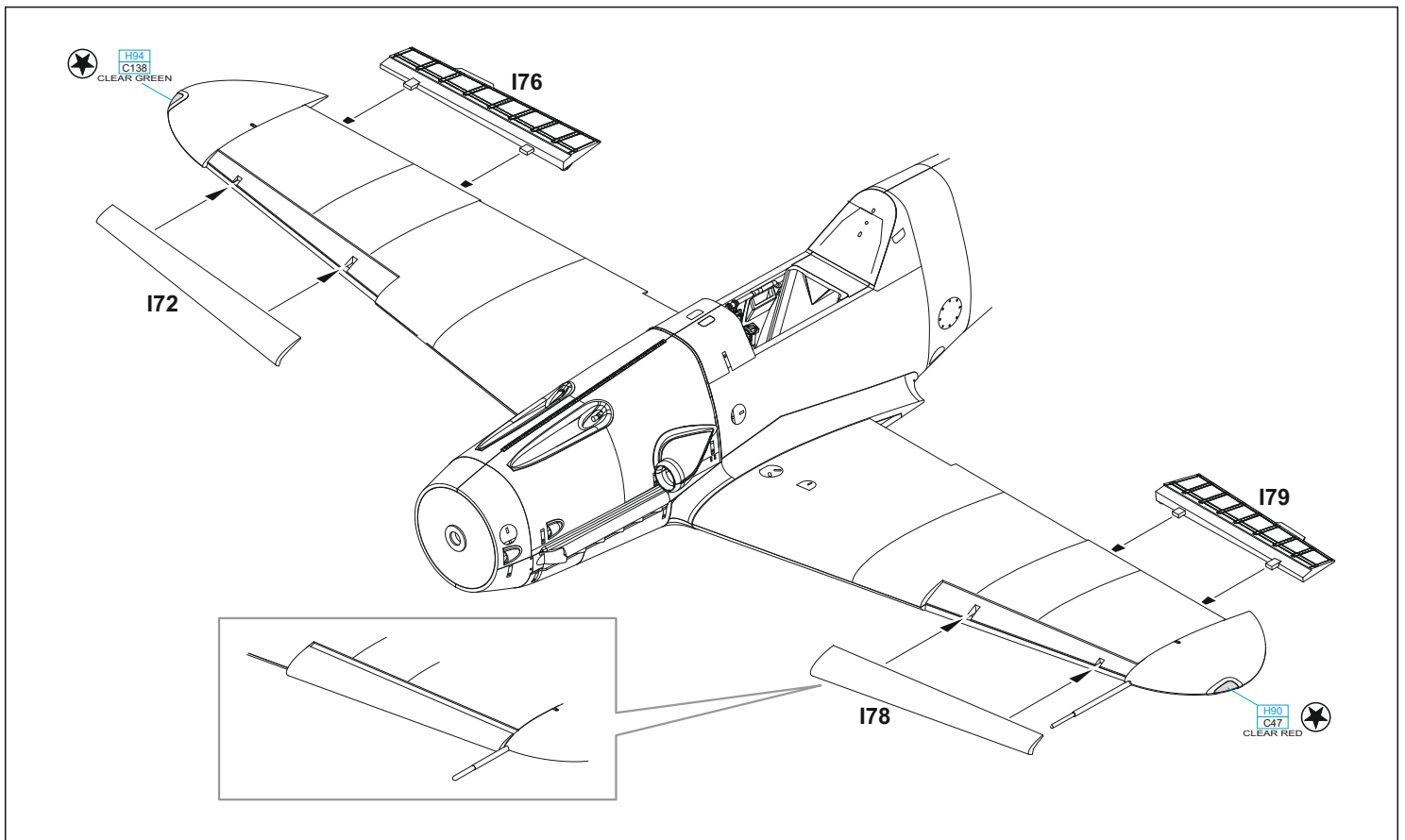

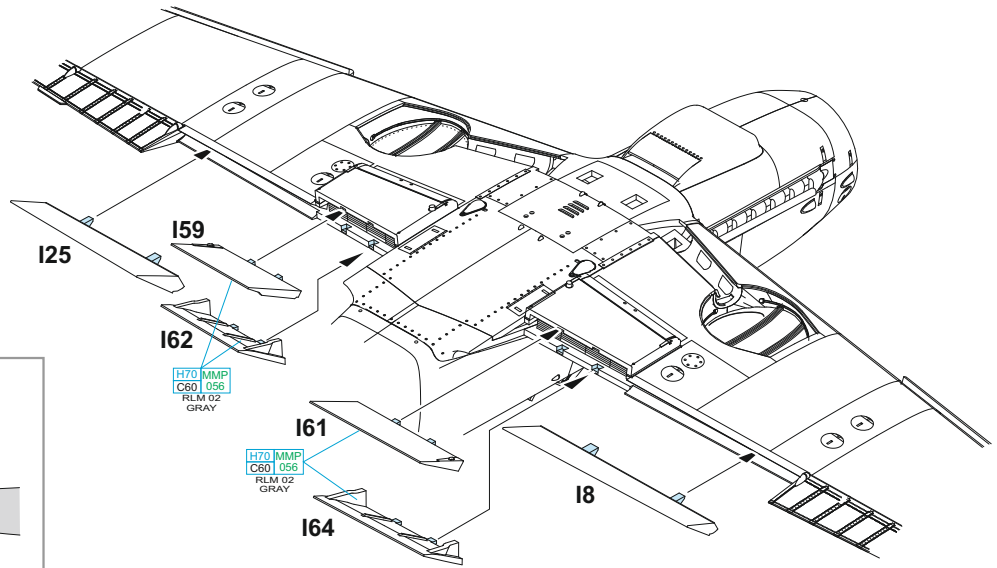

CORRECT POSITION OF RADIATOR FLAPS

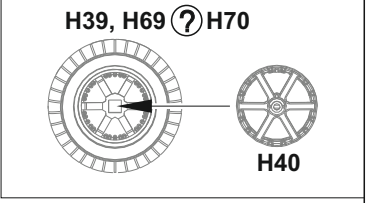
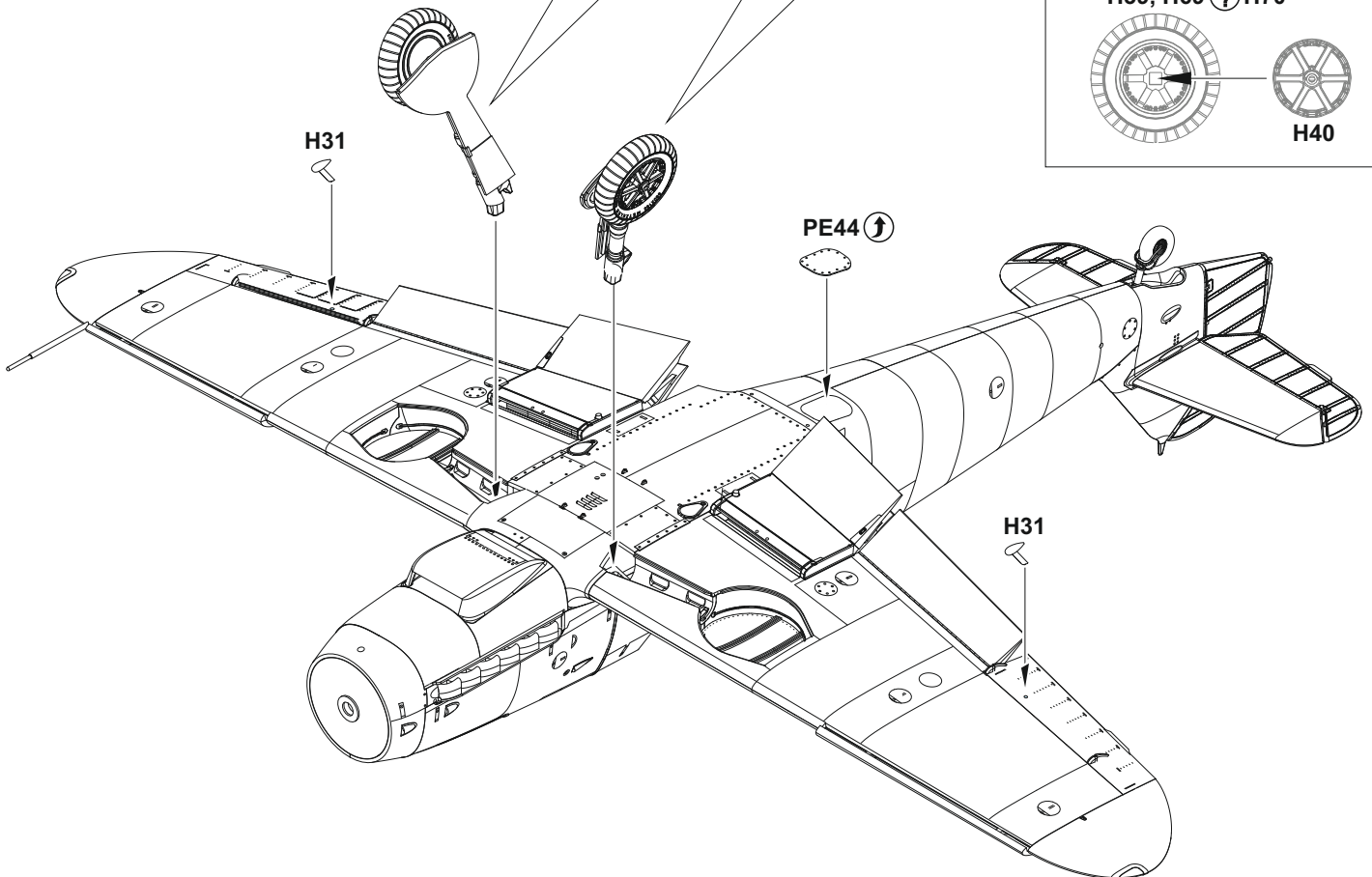
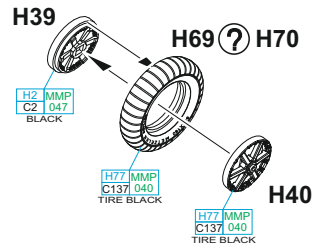
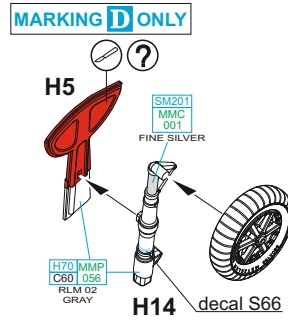
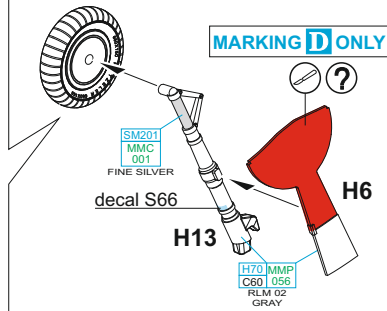
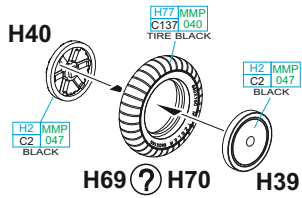
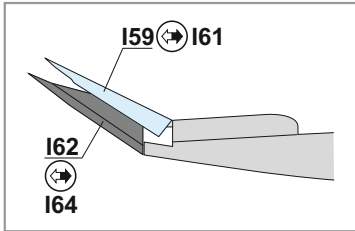

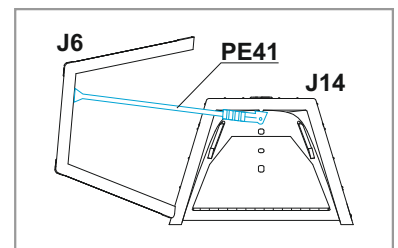
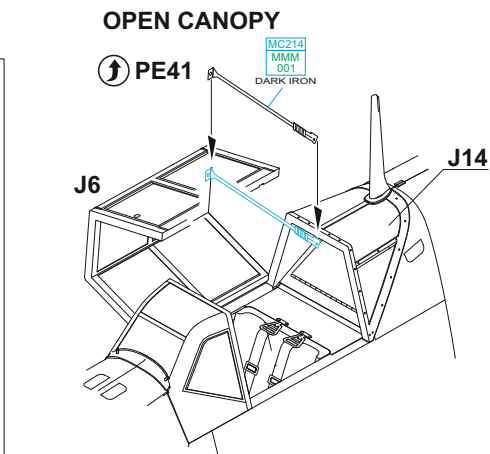
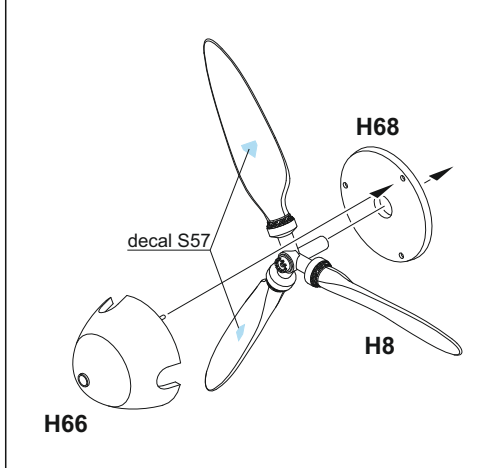
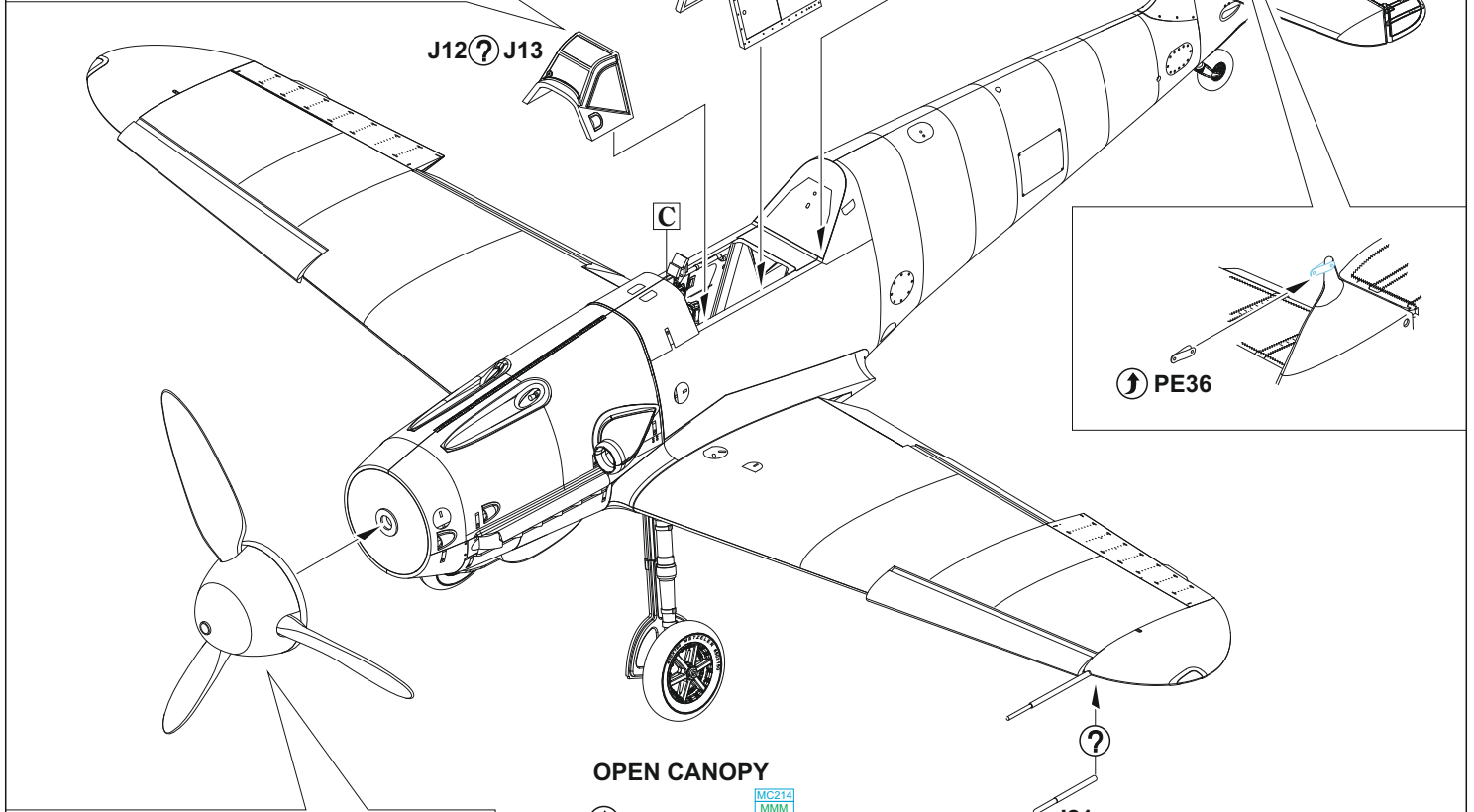
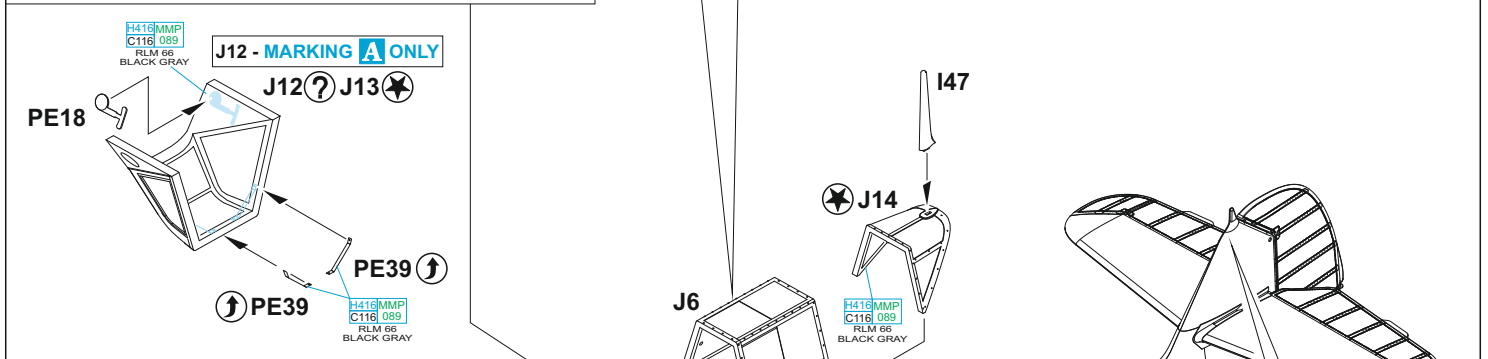
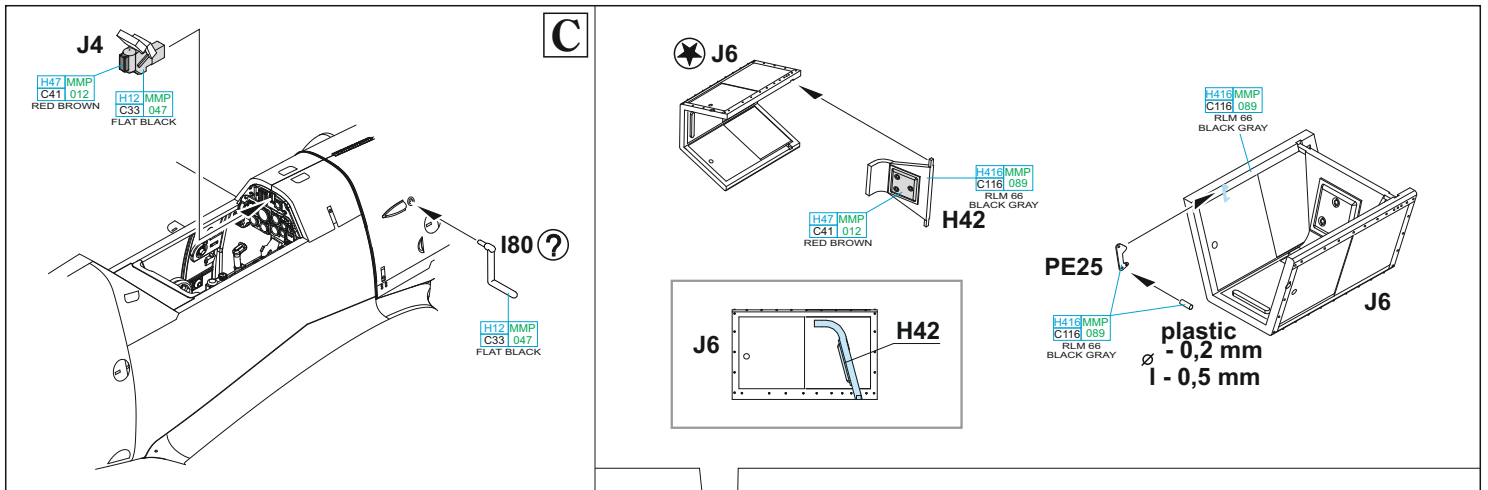

MARKINGS B, C, D, E ONLY

I70

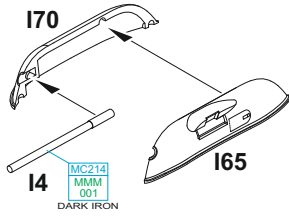

I67

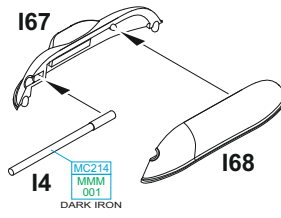

I4 MC214
MMM
001
DARK IRON

I4 MC214
MMM
001
DARK IRON

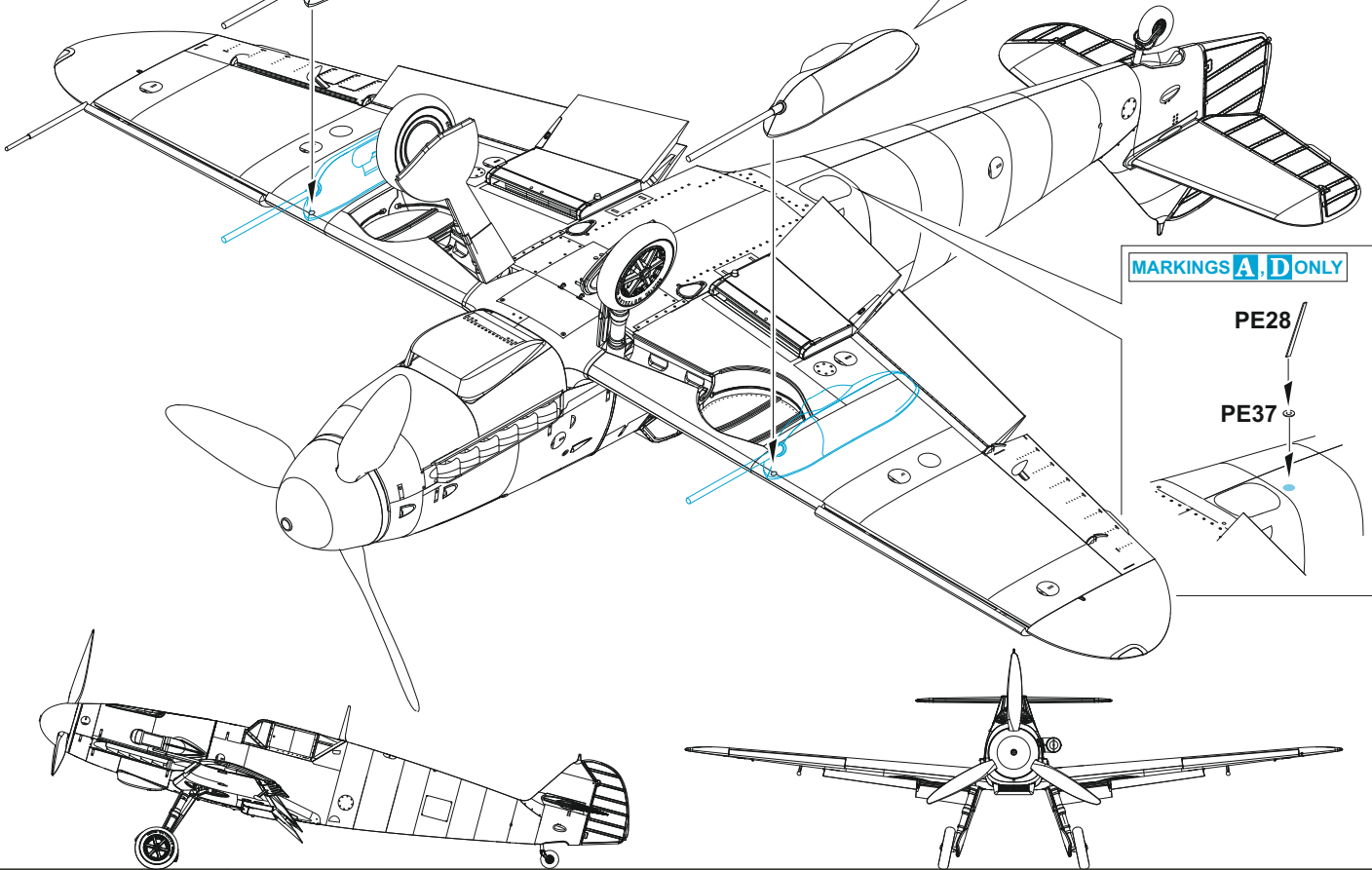

MARKINGS A, D ONLY

PE28

PE37

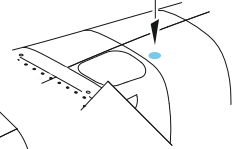

eduard
MASK
82165

inner side

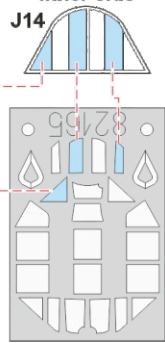

inner side

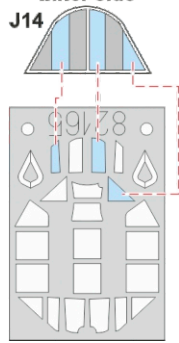

outer side

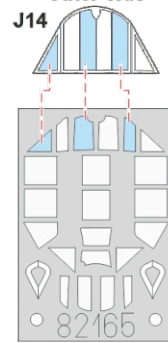

outer side

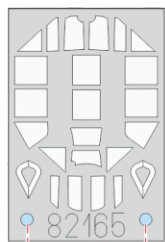
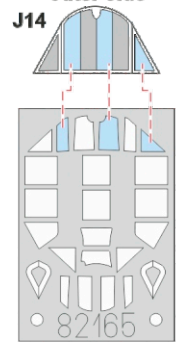

J6

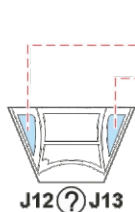
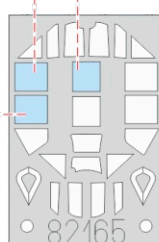
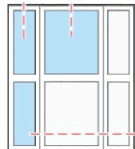

J12 ? J13

J6

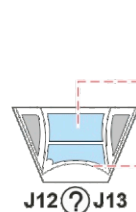
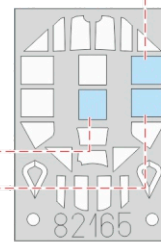
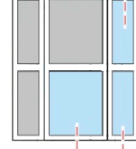

J12 ? J13

B Bf 109G-2/R-6/trop, WNr. 13916, Fw. Hans Döbrich, 6./JG 5, Alakurtti, Finland, February 1943

Hans Döbrich scored 65 kills over his combat career and was awarded the Knight's Cross of the Iron Cross for his achievements. On the other hand, he was shot down himself three times, with the final one resulting in serious injuries, preventing him to return to operational flying. Döbrich began using this aircraft on February 9, 1943. At that time he was already ace with 43 kills and also one of the II./JG 5's most successful pilots. Flying this aircraft Döbrich involuntarily took to his parachute due to engine failure on March 14, 1943, shortly after a scramble take-off from Salmijärvi. The original camouflage scheme composed of RLM 74/75/76 colours was overpainted with white squiggles to make the aircraft less visible in winter conditions. The yellow identifying markings were typical for aircraft of the Eastern Front. Döbrich's personal marking was painted under the cockpit. It was a rendition of Mickey Mouse standing over the II./JG 5's emblem and ripping apart a Soviet I-16. The green four-leaf clover on the nose was carried by aircraft of II. Gruppe of Jagdgeschwader 5

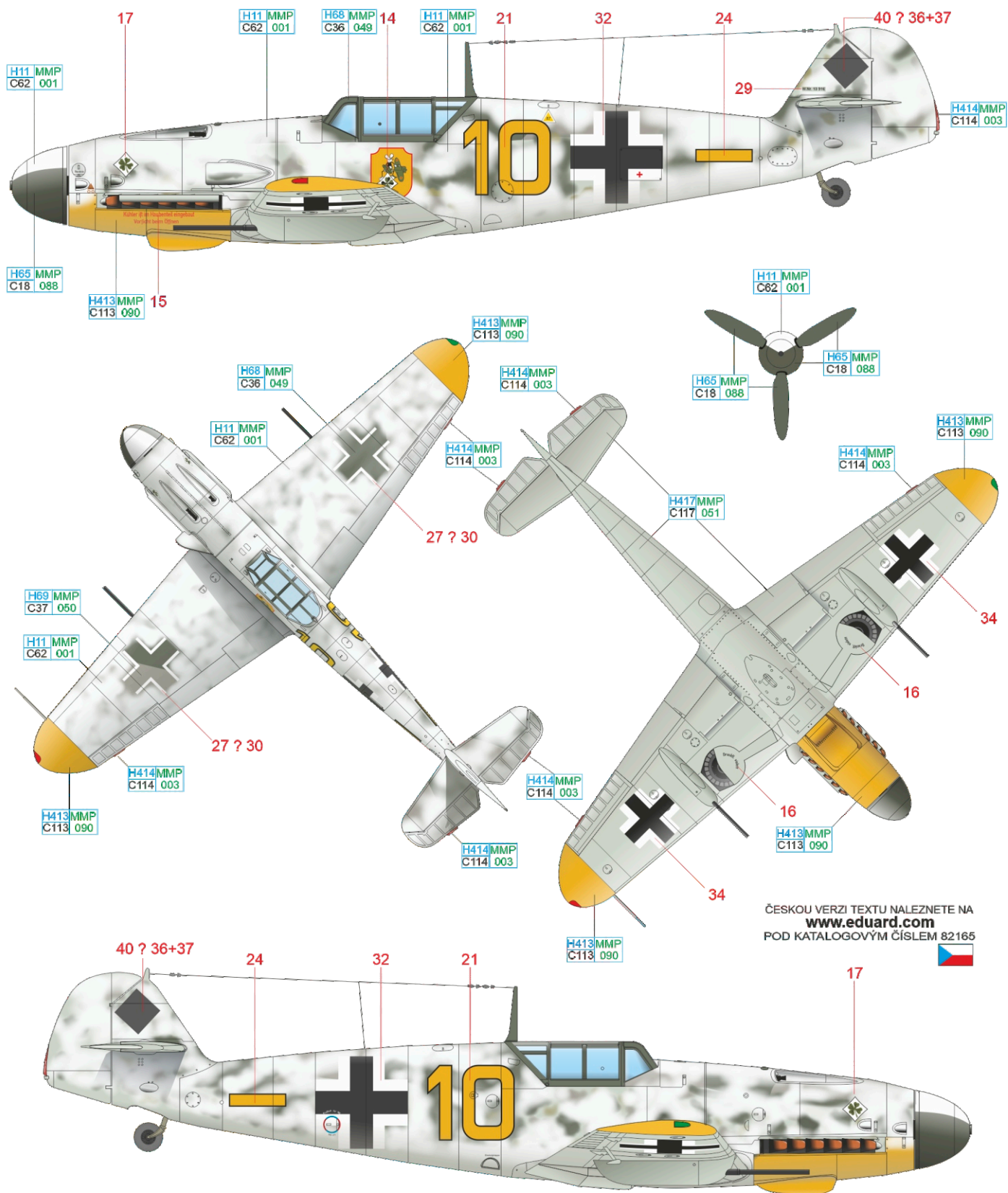

ČESKOU VERZI TEXTU NALEZNETE NA
www.eduard.com
 POD KATALOGOVÝM ČÍSLEM 82165



WHITE	H11 MMP C62 001	RLM 23	H414 MMP C114 003	RLM 70	H65 MMP C18 088
RLM 04	H413 MMP C113 090	RLM 74	H68 MMP C36 049	RLM 75	H69 MMP C37 050
				RLM 76	H417 MMP C117 051

E Bf 109G-2/R6, WNr. 13633, Hptm. Wolf-Dieter Huy, 7./JG 77, Tanyet Harun, Egypt, October 1942

Wolf-Dieter Huy joined the Kriegsmarine in 1935, and was transferred over to the Luftwaffe on October 1, 1937, where he underwent fighter training. His assignment was to (J)/TrGr. 186, the fighter unit of the Graf Zeppelin aircraft carrier. This ship was never completed, and the unit was redesignated III./JG 77. Huy took part in combat over France, as well as over Britain, and over the Balkans. The unit gained notable success in the battle for Crete and Huy, who accumulated 22 victories, was awarded the Knight's Cross on June 5, 1941. The Oak Leaves were added in March 1942. After early combats on Eastern Front the unit moved to Egypt. There, on October 29, 1942, was Wolf-Dieter Huy captured after he had been shot down by future ace J. H. Nichols who was flying a Spitfire Mk.Vc of No. 601 Squadron. Huy's Bf 109G-2 from the time the unit moved to North Africa bore the non-typical camouflage made up of RLM 70 and 71 (some sources suggest a Soviet AMT-4 Green). The yellow band behind the fuselage cross, common on aircraft serving on the Eastern Front, was hastily overpainted with a fresh colour RLM 71 (or Russian AMT-4 Green), and partially replaced by white paint used on aircraft that fought on the Southern Front. The wingtips were also painted white. The rudder was decorated with the pilot's score and awards.

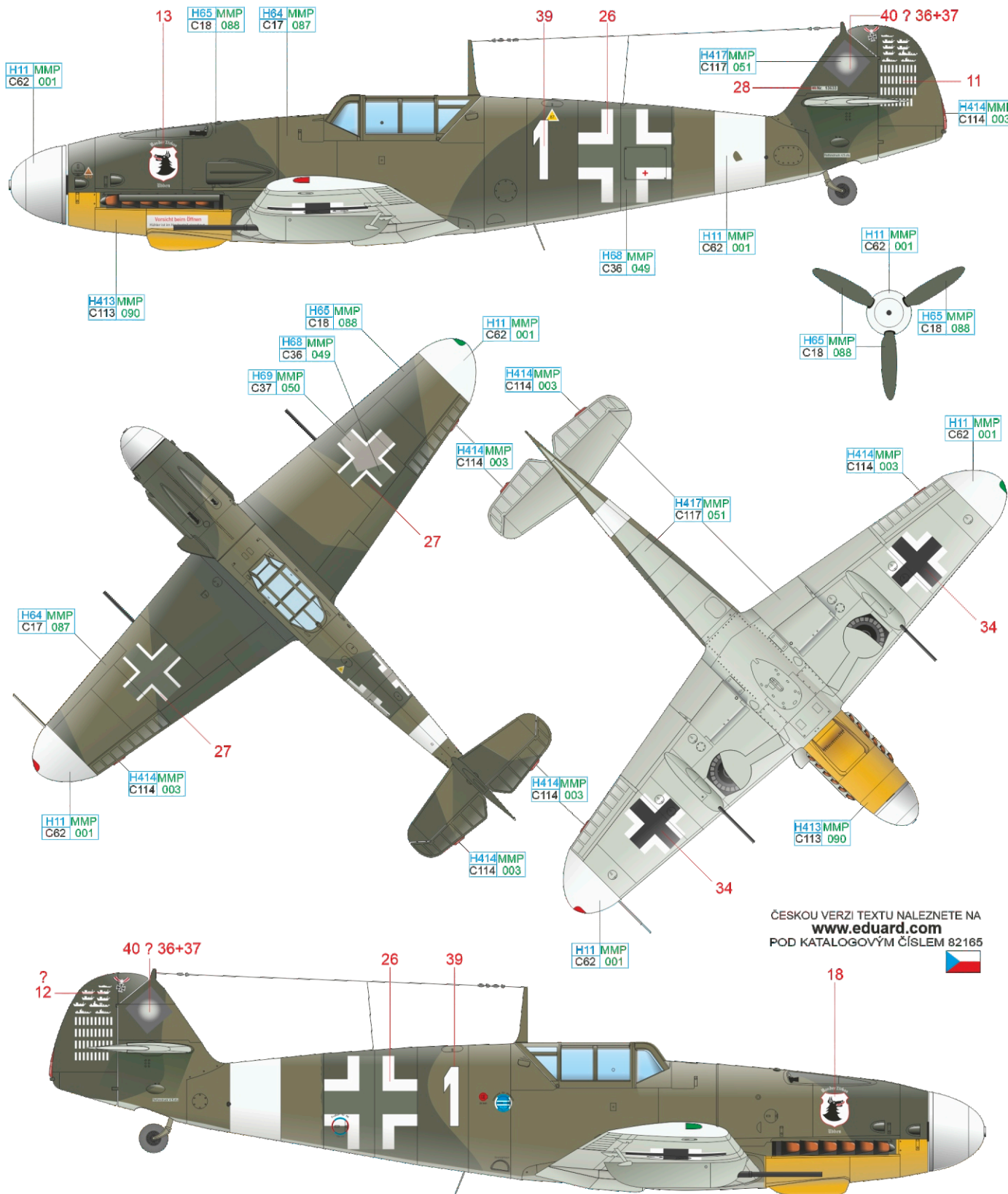

ČESKOU VERZI TEXTU NALEZNETE NA
www.eduard.com
 POD KATALOGOVÝM ČÍSLEM 82165



WHITE	H11 MMP C62 001	RLM 23	H414 MMP C114 003	RLM 70	H65 MMP C18 088	RLM 71	H64 MMP C17 087
RLM 04	H413 MMP C113 090	RLM 74	H68 MMP C36 049	RLM 75	H69 MMP C37 050	RLM 76	H417 MMP C117 051

