

FM-2 Wildcat

eduard

1/48 Scale Plastic Model Kit

ProfiPACK
edition



item No. 82205

At the outbreak of the War in the Pacific, the Wildcat was the main fighter aircraft on the carrier decks of US Navy ships. And even the introduction of more advanced Hellcat and Corsair fighters was not the end of story for their predecessor. In fact, Wildcat became a star of the escort carrier fleet and served until the end of the war.

In the early 1930's Grumman company became a major supplier of fighter aircraft to the US Navy with the FF biplane and its successors, the F2F and F3F. By 1935, however, the biplanes were reaching their limits and with the XF4F-1 prototype (factory designation G-19) Grumman failed against the cantilever monoplane Brewster F2A-1 Buffalo in the US Navy's competition for a new fighter. The XF4F-1 prototype was retained as a backup, but at Grumman they realized biplanes had become obsolete, so they redesigned it as an all-metal mid-wing monoplane, designated the XF4F-2 (G-18).

The fuselage was adopted with only minor changes, the wing employed the newly-developed NACA 230-series airfoil. Powered was delivered by a 1,000 hp (750 kW) Pratt & Whitney R-1830-66 Twin Wasp engine with a single-stage single-speed supercharger. The 110 gal (415 l) fuel tank was located beneath the cockpit with a 20 gal (75 l) reserve tank behind the pilot's seat. Armament consisted of two .30 (7.62 mm) machine guns in the fuselage and two .50 (12.7 mm) machine guns in the wing. There were also provisions for two 100lb (45kg) bombs under the wing. Undercarriage was structurally complex design adopted from previous types, which the pilot retracted manually into the fuselage using a crank. The maiden flight of the XF4F-2 occurred on September 2, 1937, and in April 1938 comparative trials were conducted with the XF2A-1 Buffalo and with the Seversky XFN-1. Although the Wildcat prototype was the fastest, it still did not meet the Navy's requirement of 300 mph (482 km/h). Finally, it was Brewster who received an order to deliver 54 units of the F2A-1 Buffalo, as this handled better, had hydraulically operated landing gear and was powered by less complicated Cyclone engine. Grumman did not give up, however, and work on an improved version of the XF4F-3 (G-36) began.

On the third try

The fuselage was lengthened to 28 ft (8.53 m) but otherwise was almost unchanged. The wingspan was also increased from 34 ft (10.36 m) to 38 ft (11.58 m) with squared-off tips. A P&W XR-1830-76 engine with a two-stage, two-speed supercharger rated at 1,200 hp (890 kW) was selected. The prototype made its maiden flight on February 12, 1939, and reached a speed of 333.5 mph (537 km/h). As deliveries of the Buffaloes were delayed, the Navy decided to order 54 Grummans, which were named Wildcat on August 8, 1939. The first of these was delivered in February 1940. Production F4F-3s had .30 fuselage machine guns removed and four .50 guns were installed in the wing. The F4F-3 wing did not yet have a folding mechanism, this was not introduced until the F4F-4 version.

In the British service

Even before the US Navy ordered the new aircraft, France rushed in, ordering 81 aircraft with the export designation G-36A. These were powered by the Wright R-1820-G205A-2 Cyclone engine with a single-stage, two-speed supercharger, developing up to 1,000 (850 kW).

Armament was to consist of six 7.5 mm Darne machine guns. However, these aircraft never made it to the customer. After the fall of France, they were rebuilt to British specification (the armament changed to four .50 machine guns) and were used by Fleet Air Arm. They served under the name Martlet (changed to Wildcat in January 1944). In all, 1,200 Wildcats of various versions were delivered to the FAA.

Pacific Lumberjack

The Wildcat was the main carrier-borne fighter of the US Navy and USMC at the time of the attack on Pearl Harbor and as such had to face a new and dangerous adversary, the Japanese Zero. Although the Wildcat lagged it in terms of performance and maneuverability, its rugged design, strong armor protection and self-sealing fuel tanks made it tough opponent. In addition, their pilots were also helped by the defensive tactics developed by Lt. Cmdr. John S. "Jimmy" Thach and named the Thach Weave. During the fighting for Guadalcanal, Wildcat pilots also used the "hit and run" high altitude ambush tactics with success. In 1943 new American fighters Grumman F6F-3 Hellcat and Vought F4U-1 Corsair were introduced and Grumman stopped the production of the Wildcat. A total of 7,860 Wildcats and Martlets of all versions were produced.

This kit: FM-1 Wildcat

In early 1943, Grumman ceased production of the Wildcat, but this did not mean the end of the Wildcat. The Navy needed compact fighter aircraft for the rapidly growing number of its escort carriers and that brought a "second life" to the type. Escort carriers were smaller than standard ones, so the new Hellcats and Corsairs were not suited for them. Grumman, fully occupied with the production of Hellcats and Avengers, therefore assigned the production to General Motors and its newly formed Eastern Aircraft Division. Aircraft produced there were designated FM-1. First ten of them were manufactured with six guns, starting with 11th example, the armament was reduced to four guns.

As there was not enough time to develop new compact fighter for escort carriers, the Wildcat got another step in its development. The main difference of the new version of Wildcat was substitution of the 1,200 h.p. R-1830-86 with a 1,350 h.p. Wright R-1820-56 Cyclone that was also 230 lbs. lighter. The XF4F-8 had four guns like the FM-1; it was visually distinguished thanks to an enlarged rudder and vertical stabilizer to counteract the increased torque of the more powerful engine. The airplane was 530 lbs. lighter than the F4F-4. Initial climb rate was nearly doubled, service ceiling was boosted to 36,400 ft. All in all, this was quite a "wilder" Wildcat. It went into production in early 1943; between then and August 1945 4,437 FM-2s were delivered, making it the most numerous Wildcat of all.

In the Pacific, the FM-2 showed up in the new Composite Squadrons (VC) in the fall of 1943. During the invasions of the Marshalls, Carolines, Marianas, and the Philippines, ten more Wildcat pilots became aces.

ATTENTION



UPOZORNĚNÍ



ACHTUNG



ATTENTION



注意



Carefully read instruction sheet before assembling. When you use glue or paint, do not use near open flame and use in well ventilated room. Keep out of reach of small children. Children must not be allowed to suck any part, or pull vinyl bag over the head.



Před započítím stavby si pečlivě prostudujte stavební návod. Při používání barev a lepidel pracujte v dobře větrané místnosti. Lepidla ani barvy nepoužívejte v blízkosti otevřeného ohně. Model není určen malým dětem, mohlo by dojít k požití drobných dílů.

INSTRUCTION SIGNS * INSTR. SYMBOLS * INSTRUKTION SINNBILDEN * SYMBOLES * 記号の説明

OPTIONAL
VOLBABEND
OHNOUTSAND
BROUSITOPEN HOLE
VYVRTAT OTVORSYMETRICAL ASSEMBLY
SYMETRICKÁ MONTÁŽREMOVE
ODRÍZNOUTREVERSE SIDE
OTOČITAPPLY EDUARD MASK
AND PAINT
POUŽÍT EDUARD MASK
NABARVITPLEASE CHECK THE LATEST VERSION OF THE INSTRUCTIONS ON www.eduard.com

PARTS



DÍLY



TEILE



PIÈCES



部品

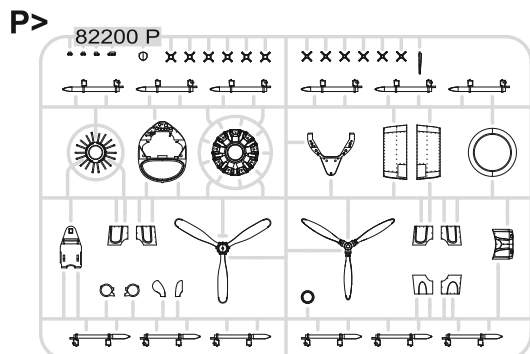
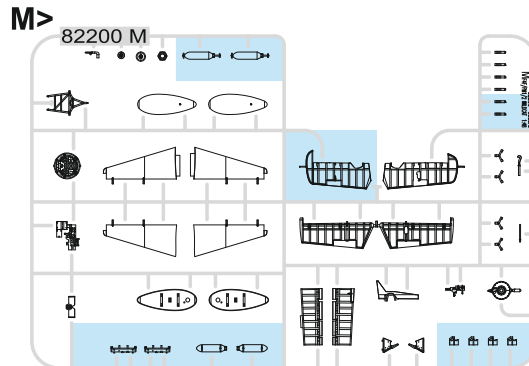
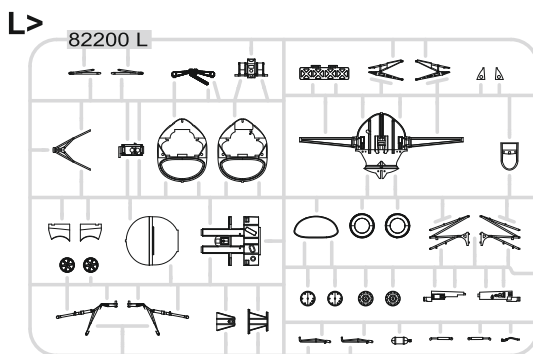
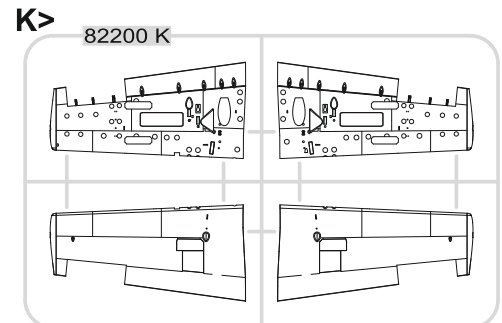
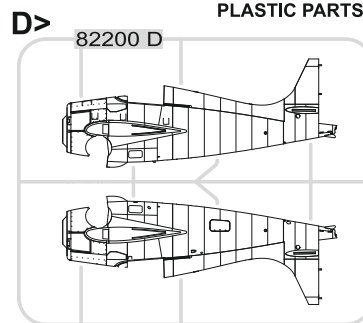
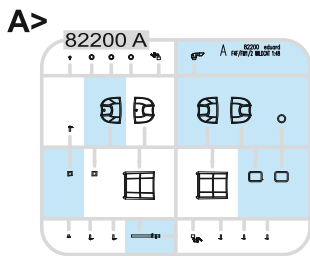

PE - PHOTO ETCHED DETAIL PARTS

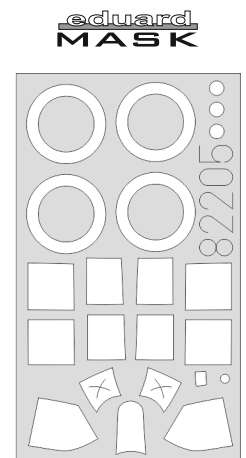
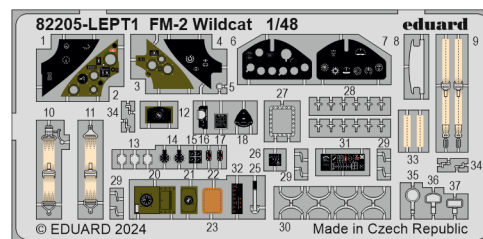

-Parts not for use. -Teile werden nicht verwendet. -Pièces à ne pas utiliser. -Tyto díly nepoužívejte při stavbě. - 使用しない部品

COLOURS



BARVY



FARBEN



PEINTURE



色

GSI Creos (GUNZE)		
AQUEOUS	Mr.COLOR	
H1	C1	WHITE
H2	C2	BLACK
H6	C6	GREEN
H8	C8	SILVER
H12	C33	FLAT BLACK
H47	C41	RED BROWN
H52	C12	OLIVE DRAB
H54	C365	NAVY BLUE
H56	C366	INTERMEDIATE BLUE
H58	C351	INTERIOR GREEN
H77	C137	TIRE BLACK
H85	C45	SAIL COLOR
H90	C47	CLEAR RED
H92	C49	CLEAR ORANGE
H93	C50	CLEAR BLUE

GSI Creos (GUNZE)		
AQUEOUS	Mr.COLOR	
H94	C138	CLEAR GREEN
H306	C306	MEDIUM GRAY
H316	C316	WHITE
H317	C317	GRAY
H325	C325	GRAY
H327	C327	RED
H329	C329	YELLOW
Mr.METAL COLOR		
MC214		DARK IRON
MC218		ALUMINIUM
MC219		BRASS
Mr.COLOR SUPER METALLIC		
SM201		SUPER FINE SILVER

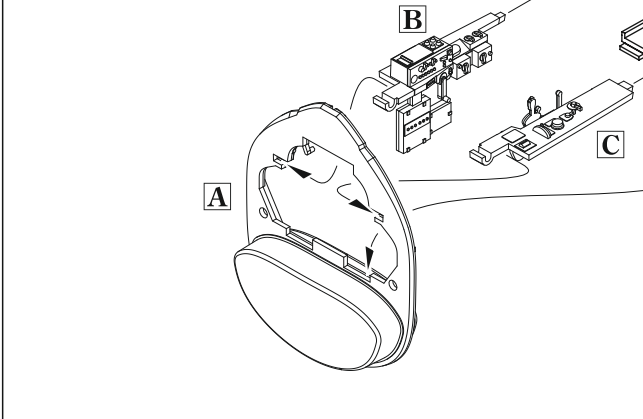
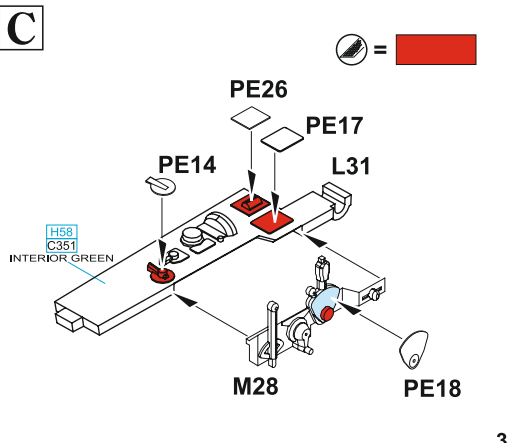
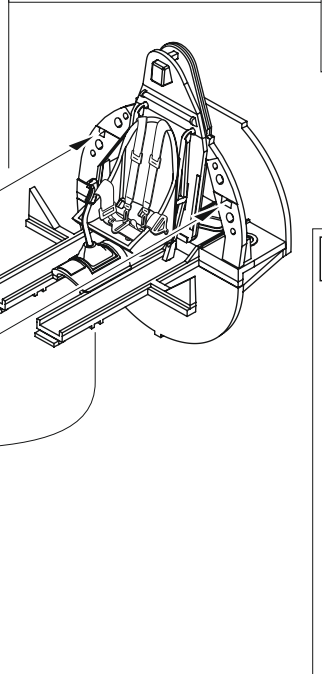
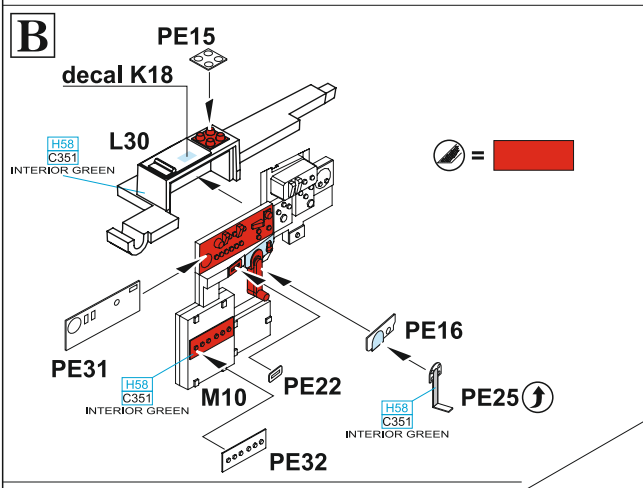
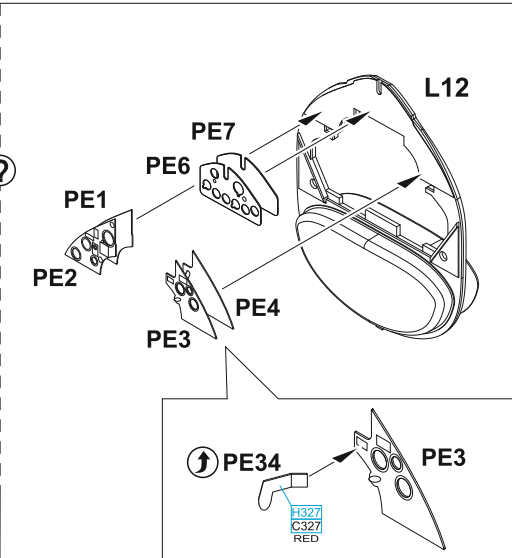
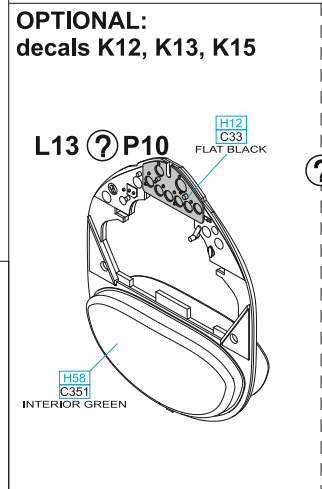
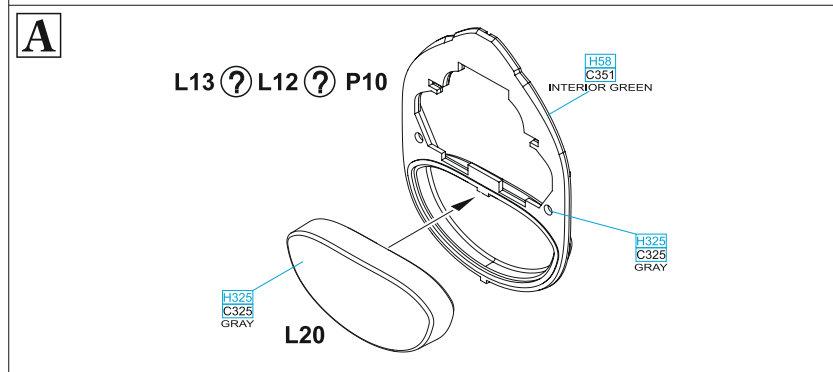
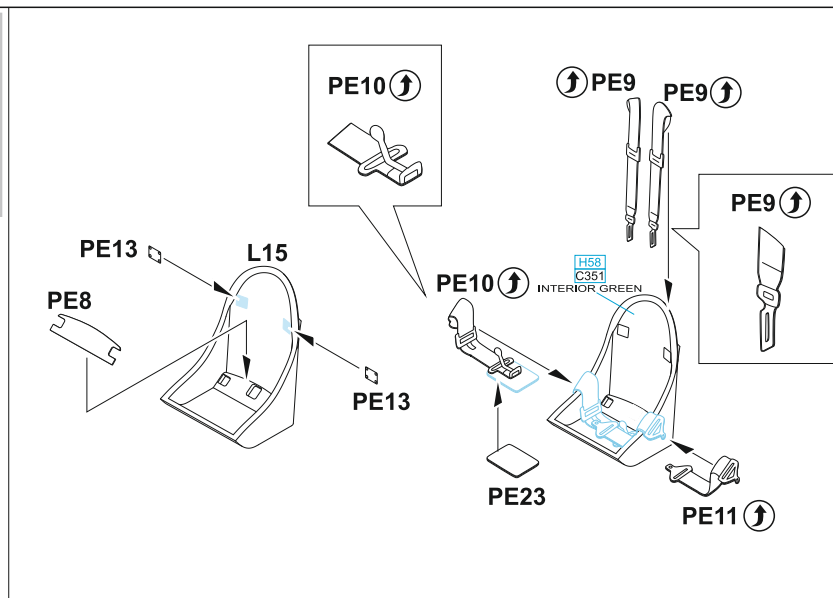
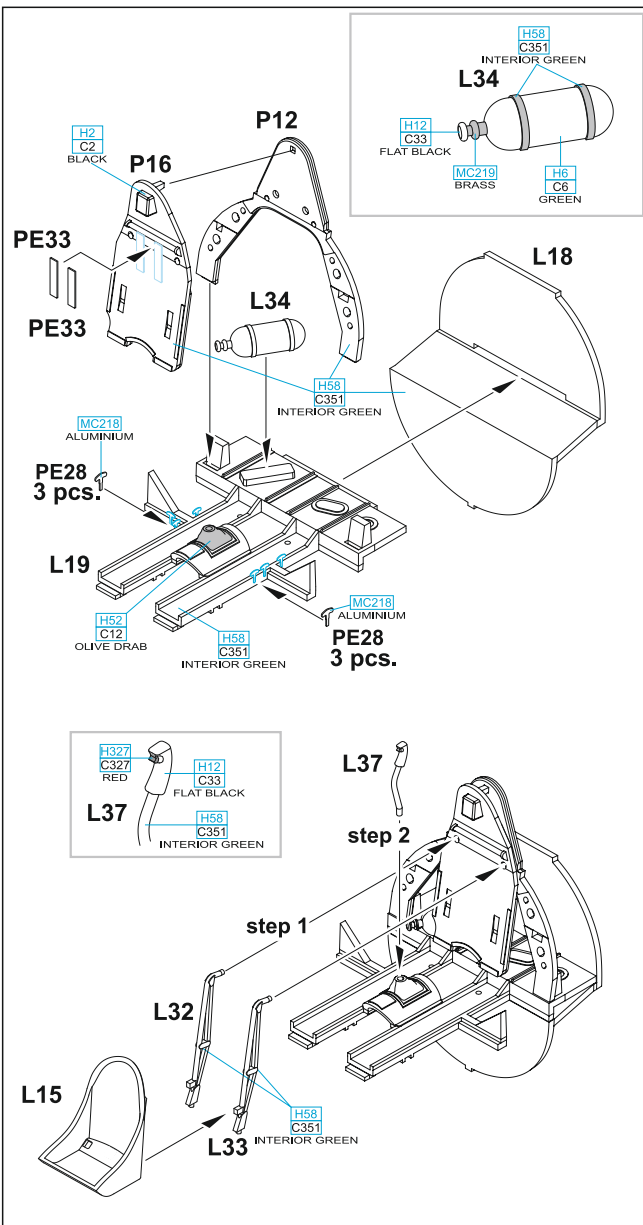

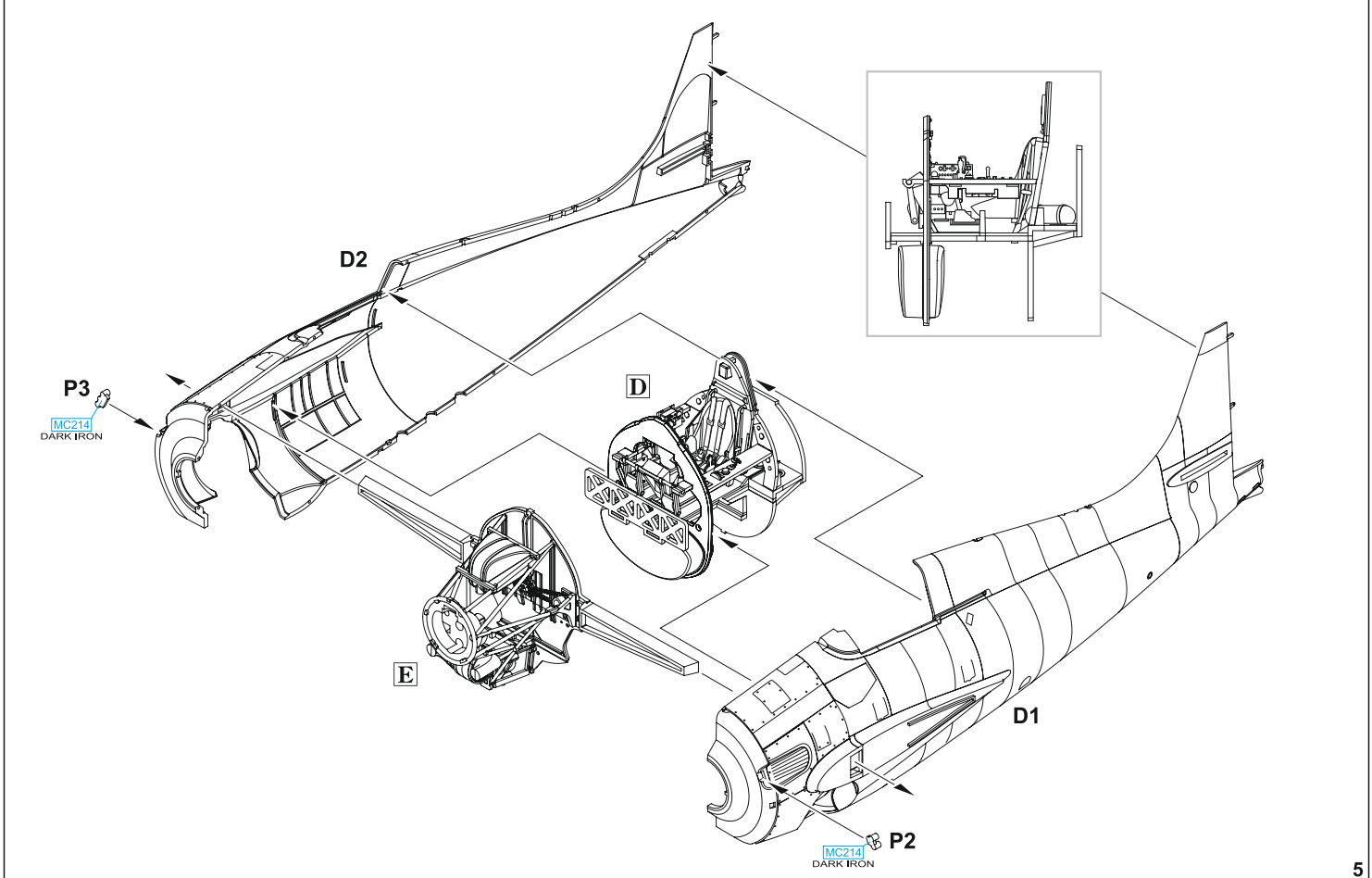
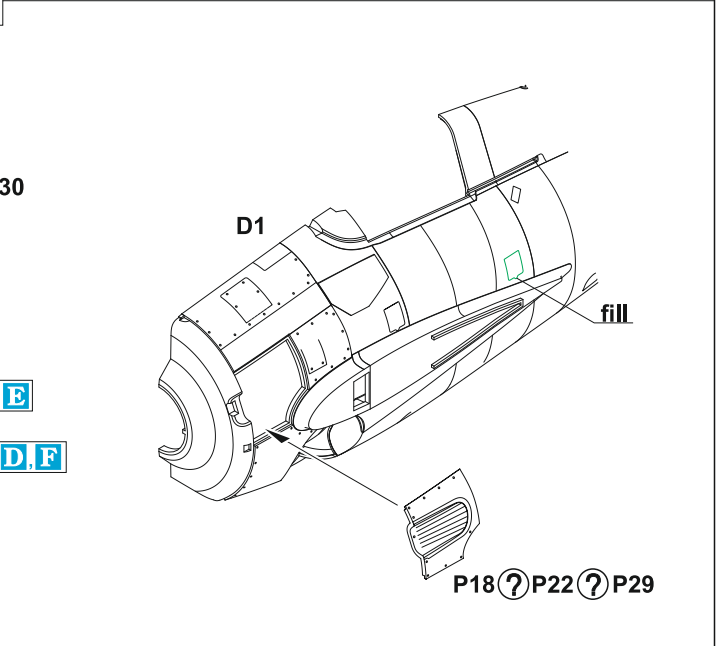
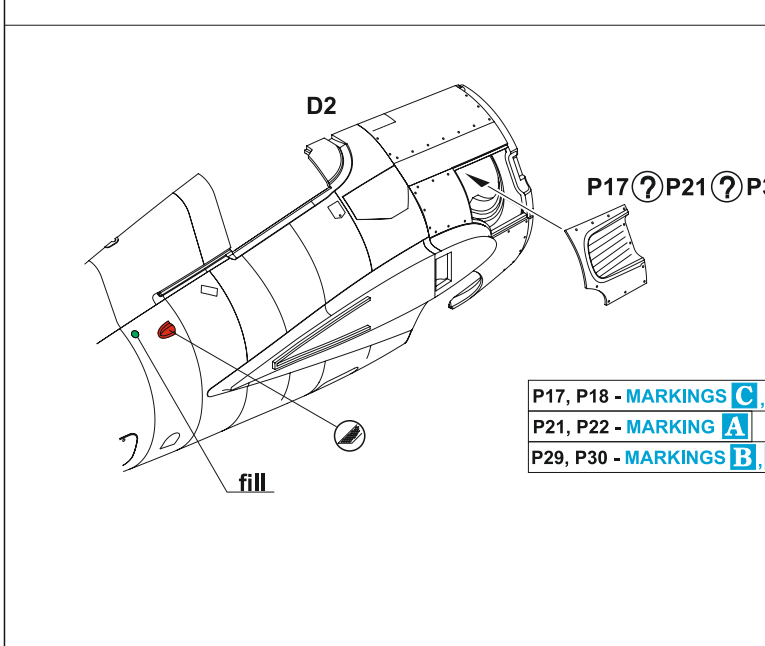
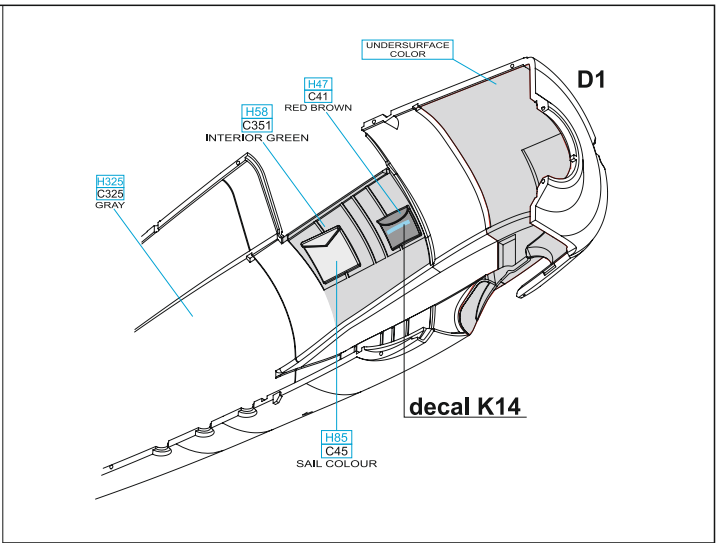
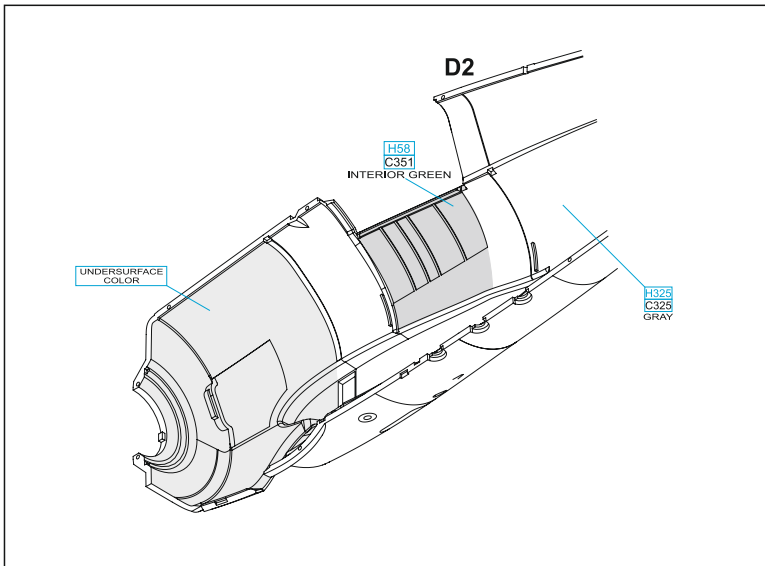

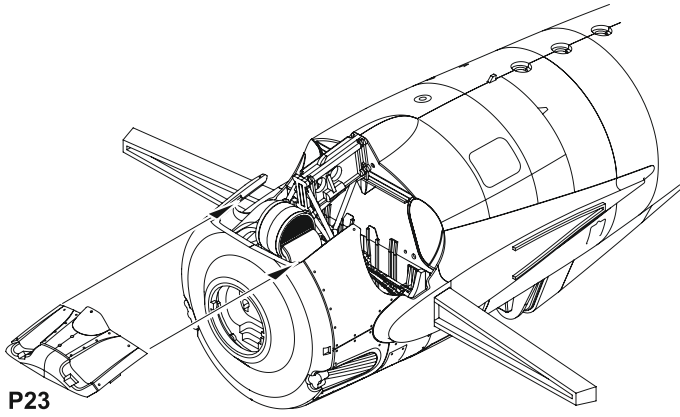

P23

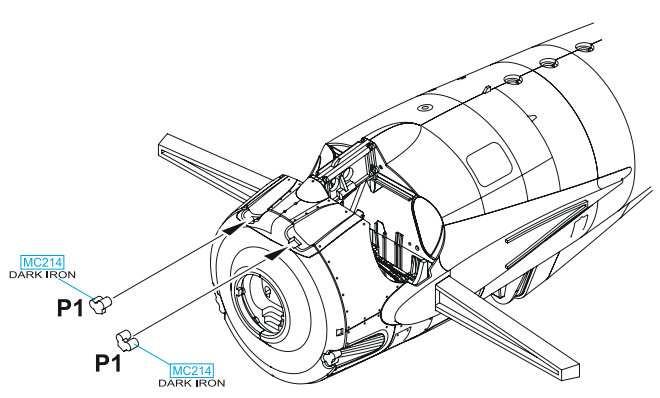

MC214
DARK IRON

P1

P1

MC214
DARK IRON

F

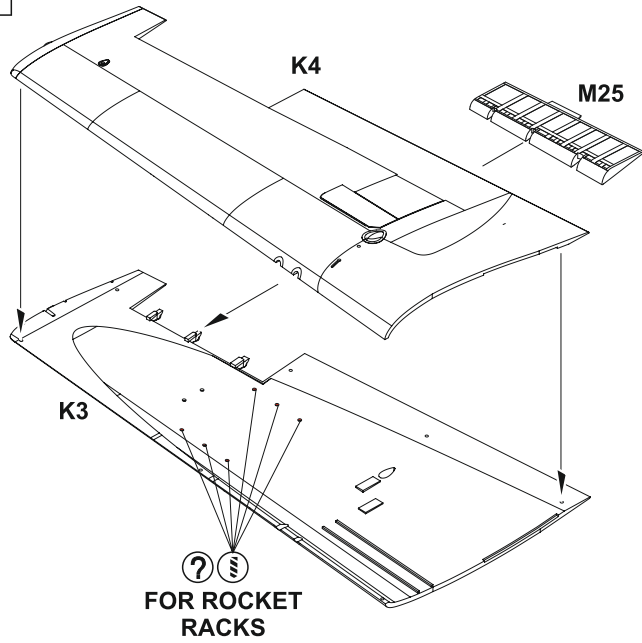

K4

M25

K3

FOR ROCKET RACKS

G

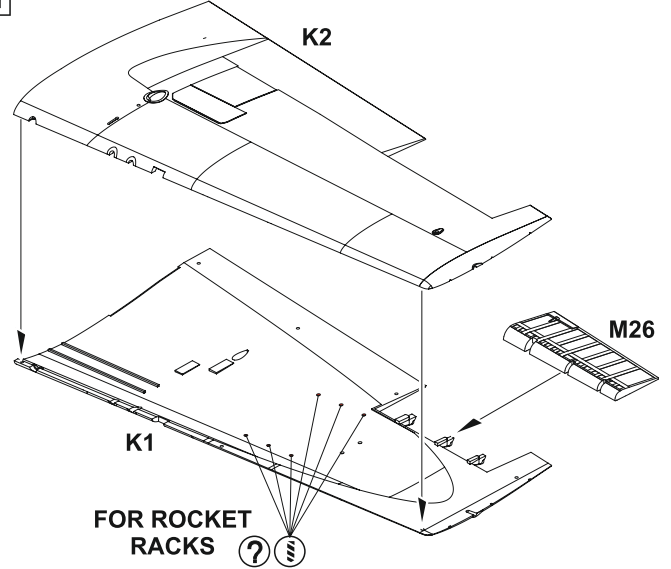

K2

M26

K1

FOR ROCKET RACKS

H

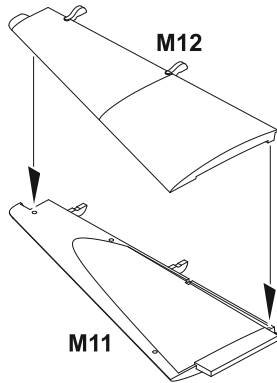

M12

M11

I

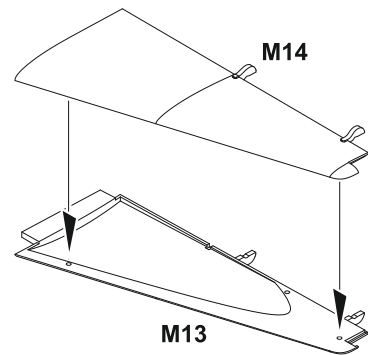

M14

M13

J

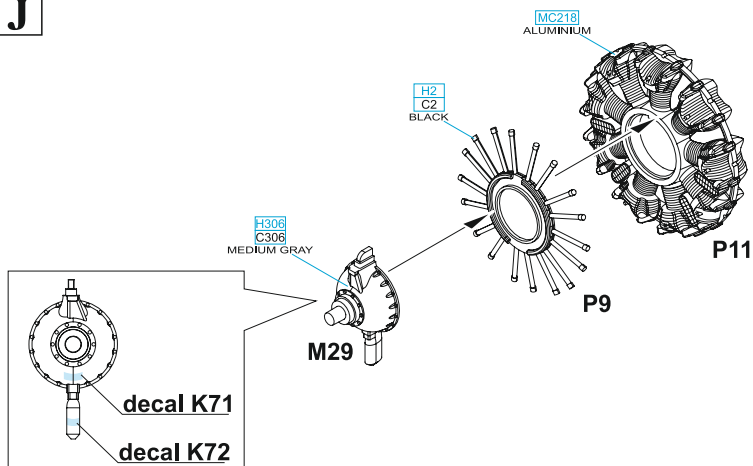

MC218
ALUMINIUM

H2
C2
BLACK

H306
C306
MEDIUM GRAY

P11

P9

M29

decal K71

decal K72

K

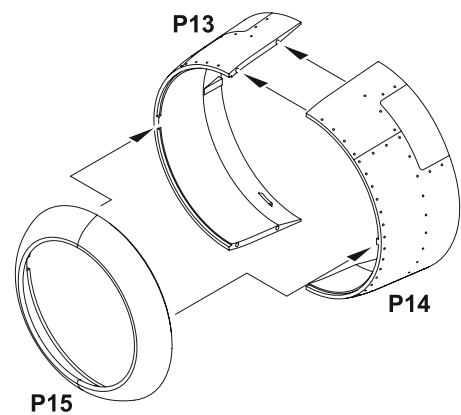

P13

P14

P15

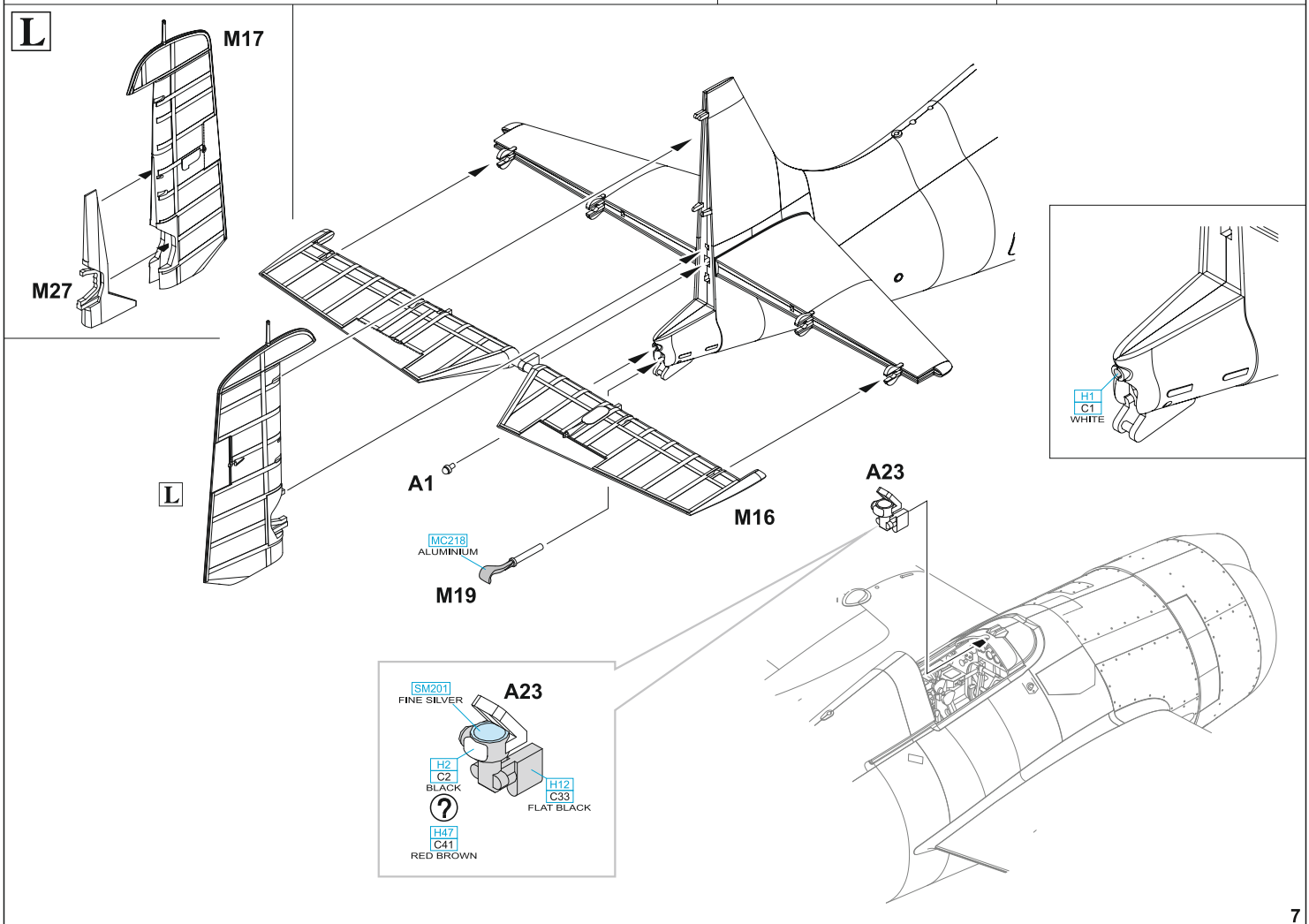
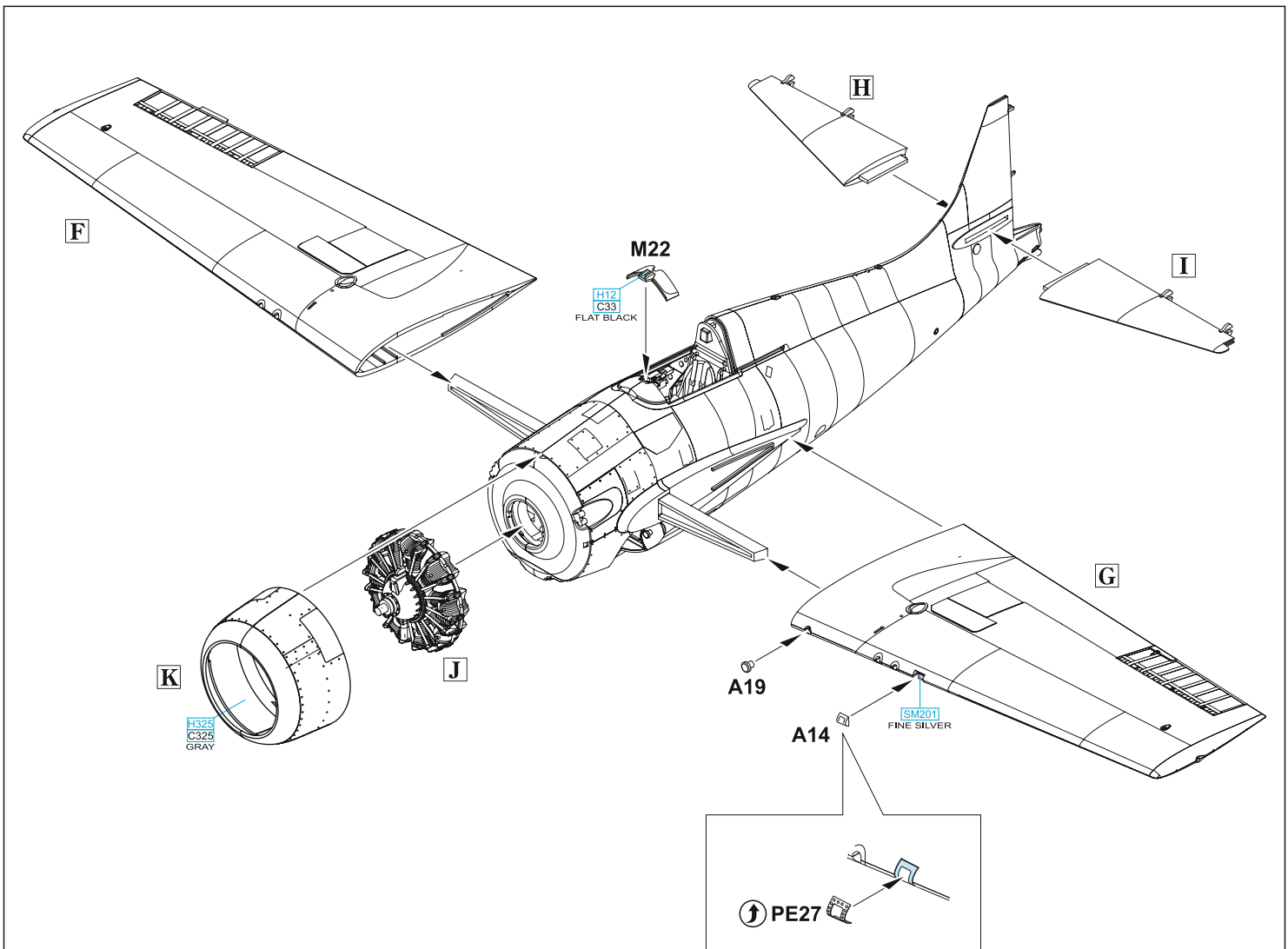

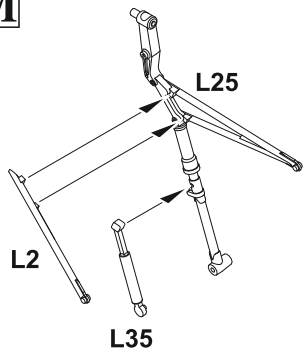
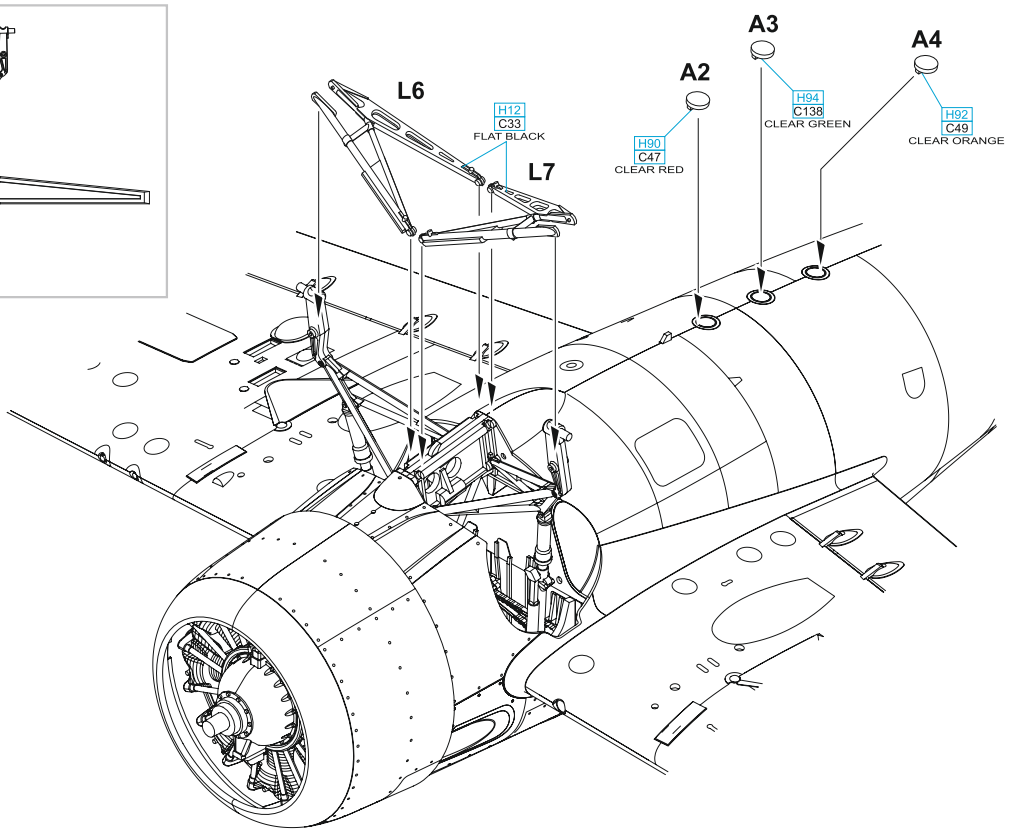
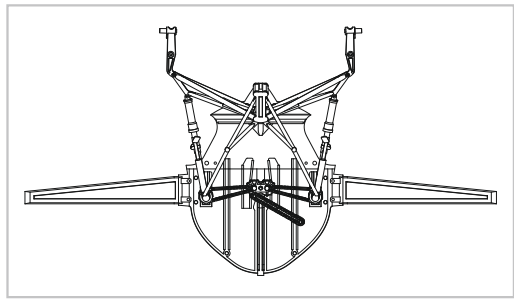
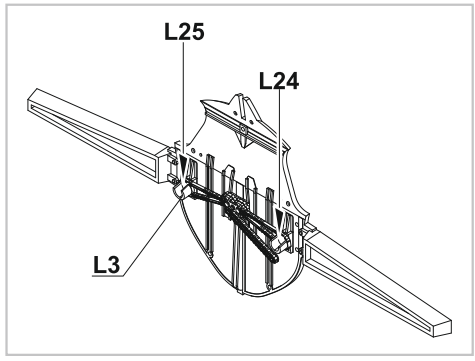
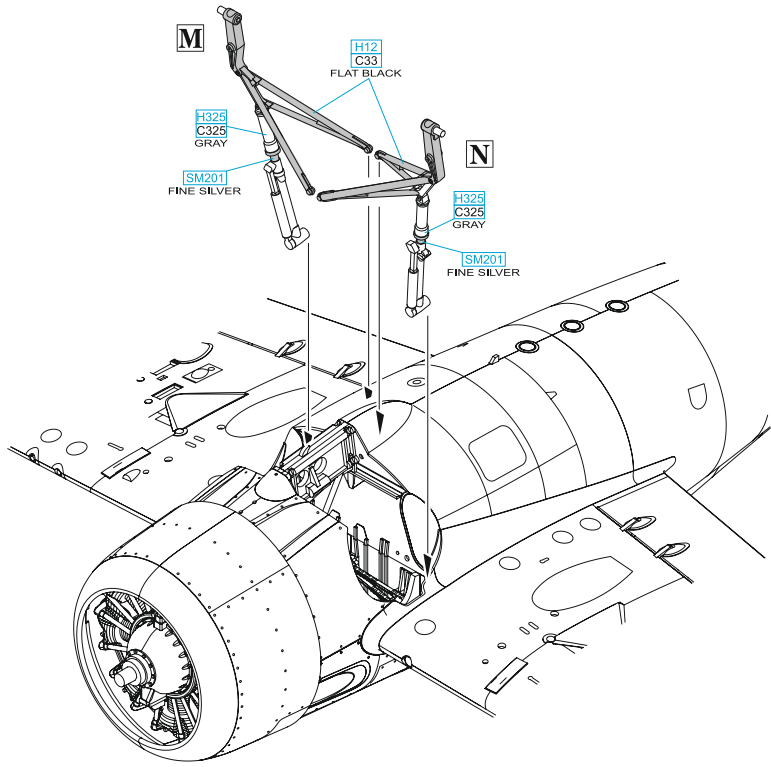
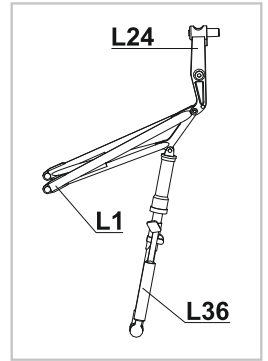
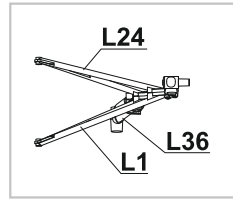
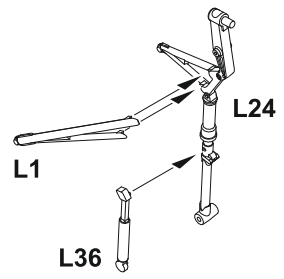
M**N**

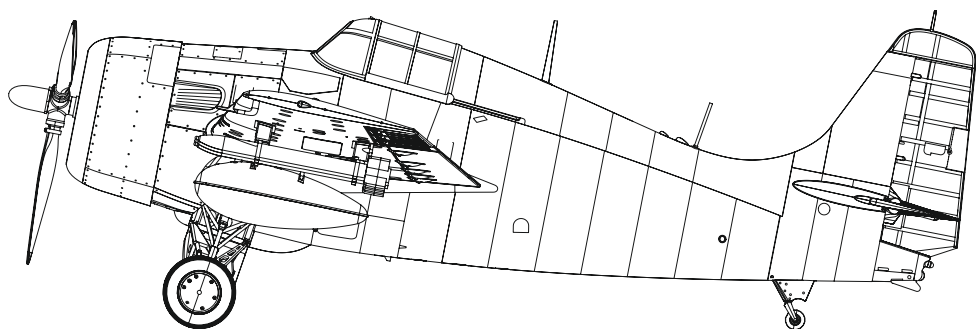
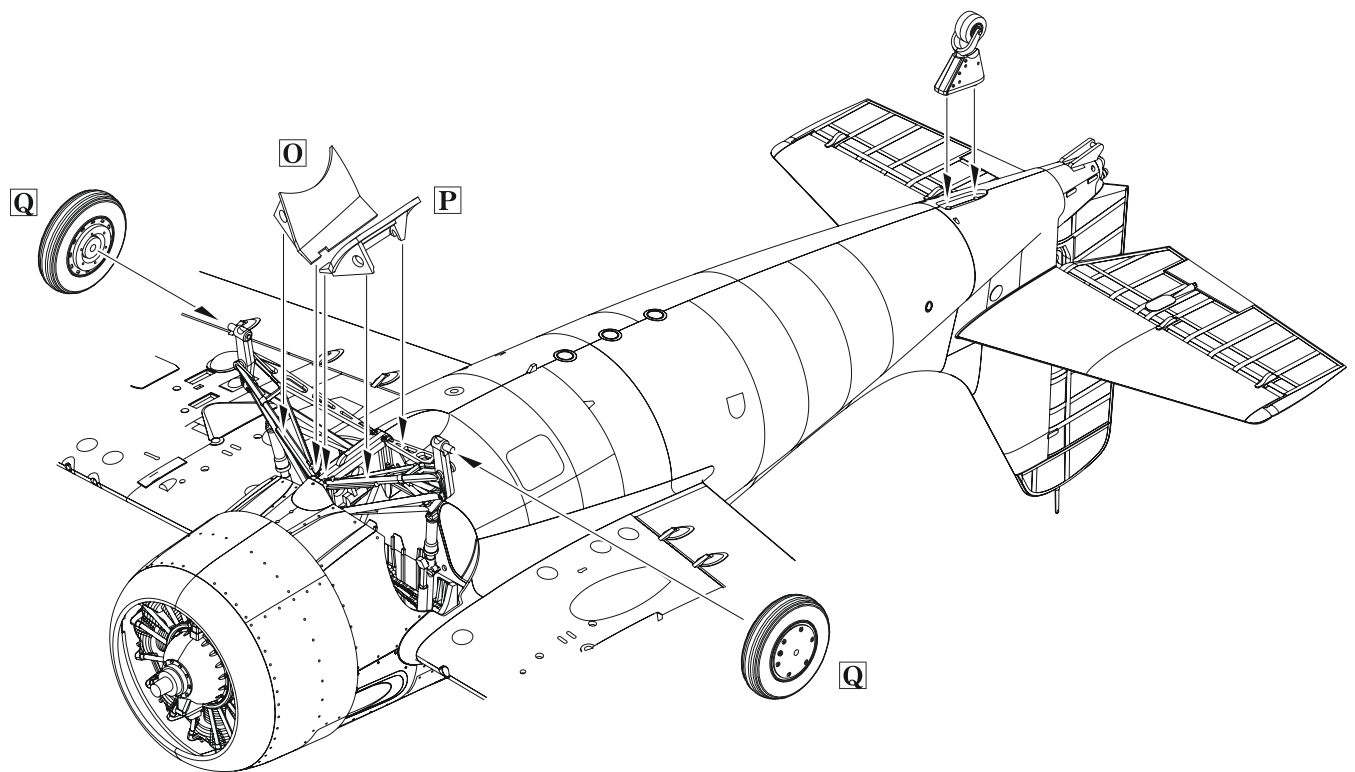
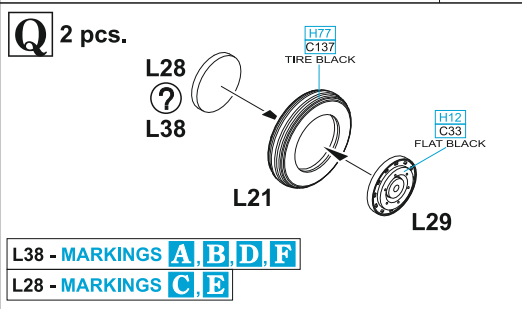
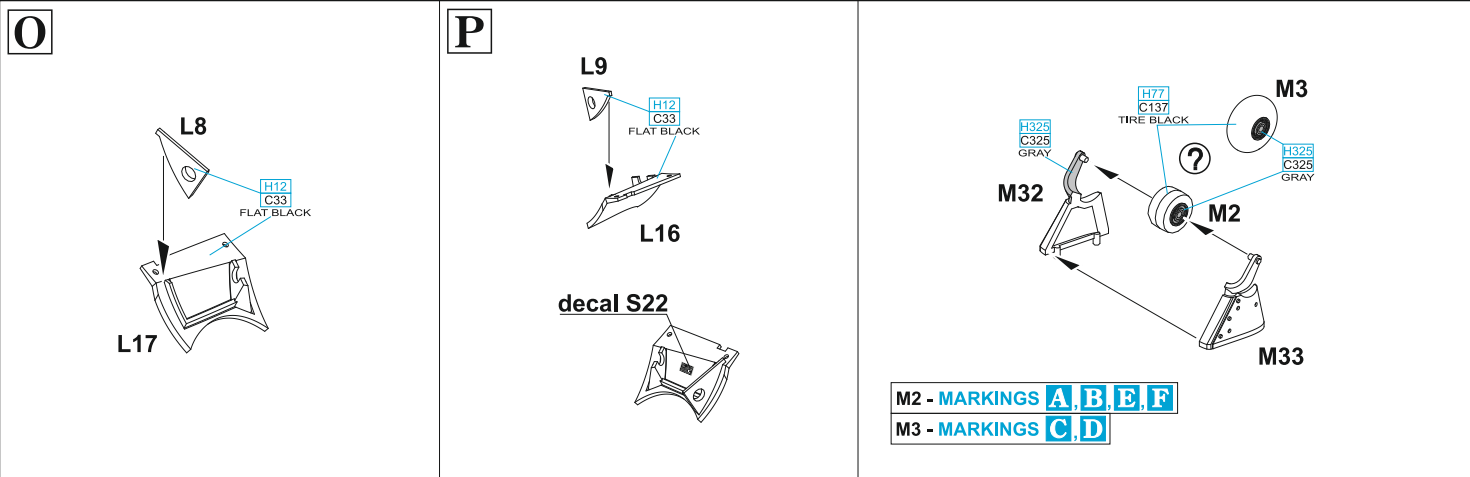

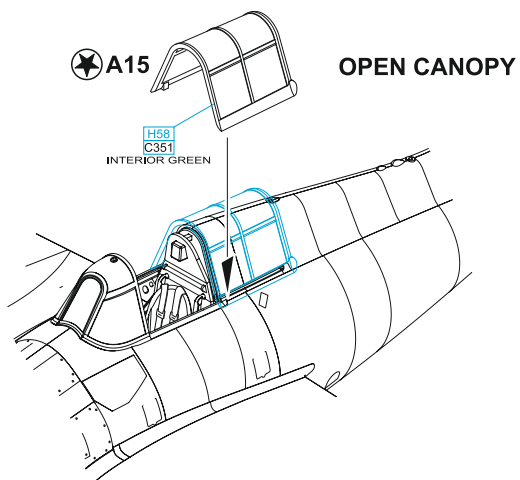

R PE35 - MARKING **F** ONLY

PE35 $\varnothing - 2,1 \text{ mm}$ 1,9 mm

CREATE AN AERODYNAMICAL BACK OF THE REAR-VIEW MIRROR

CLOSED CANOPY

M21 ? MARKINGS **A, B, D, E** ONLY

A24 H94 C138 CLEAR GREEN

A20

A9 H54 C365 NAVY BLUE

A16 H53 C351 INTERIOR GREEN

A7 H1 C1 WHITE

P7

A26 H93 C50 CLEAR BLUE

M8 MC214 DARK IRON

M8 MC214 DARK IRON

M8 MC214 DARK IRON

A25 H90 C47 CLEAR RED

A21 H90 C47 CLEAR RED

M4 ? **P4**

P20

P19 ?

P19 ?

P19 ?

M4 ? **P4**

P19

P19 - MARKING B

P19 + M4 - MARKINGS A, E

P19 + P4 - MARKING D

P20 + M4 - MARKING C

P20 + P4 - MARKING F

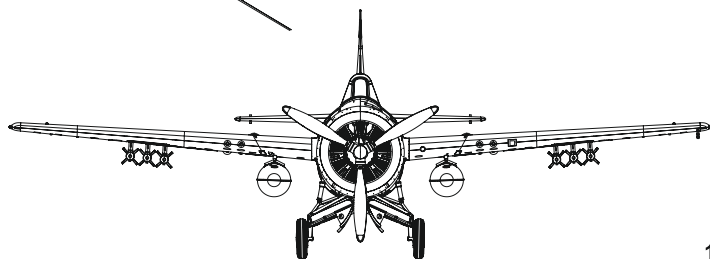
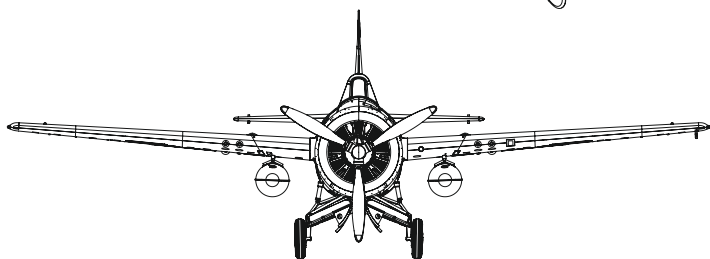
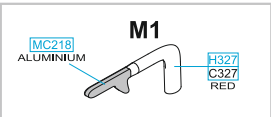
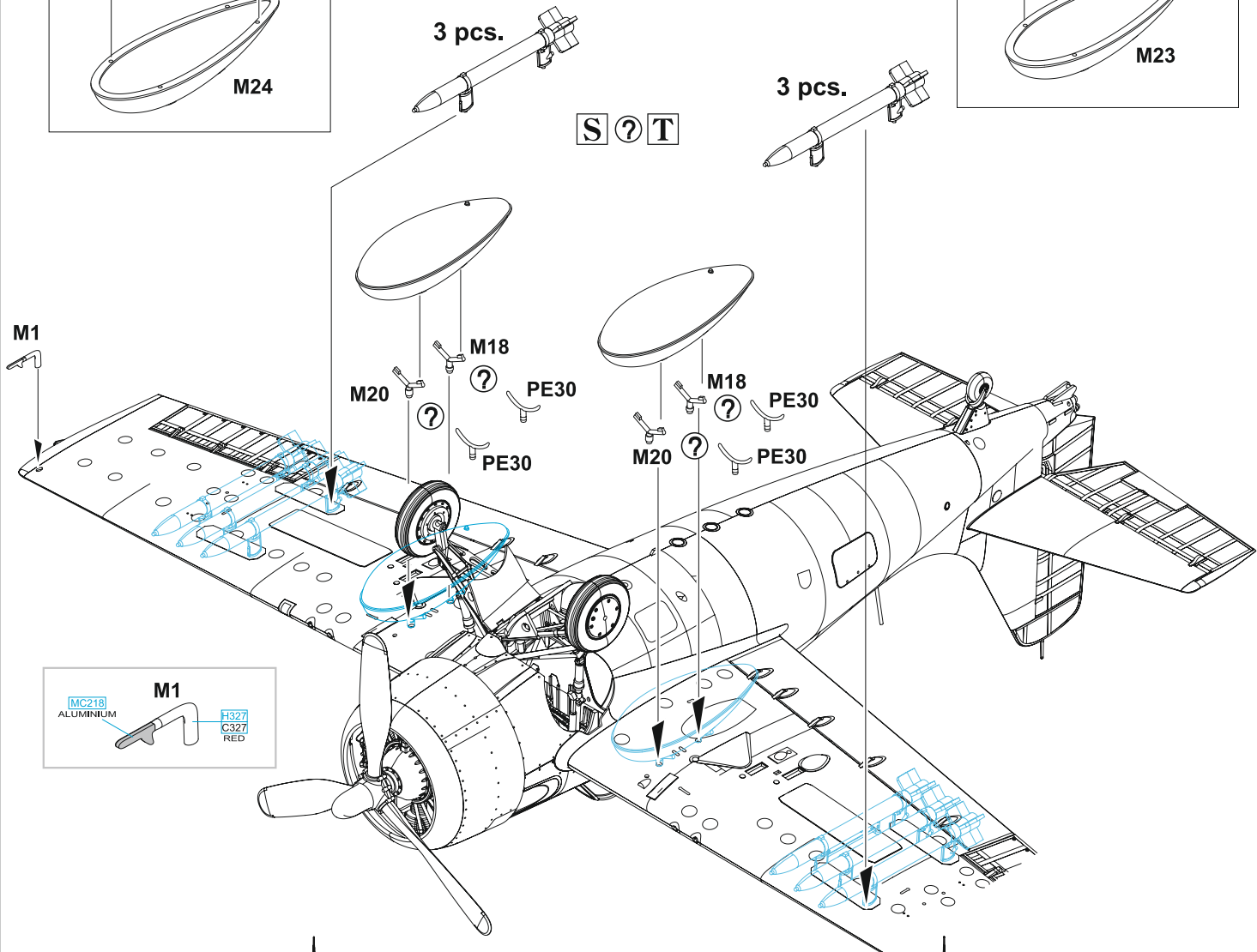
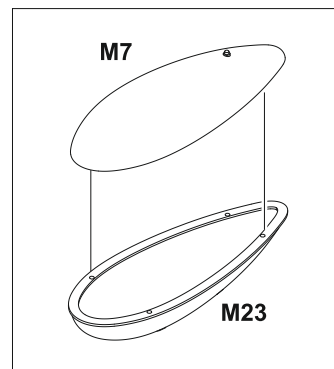
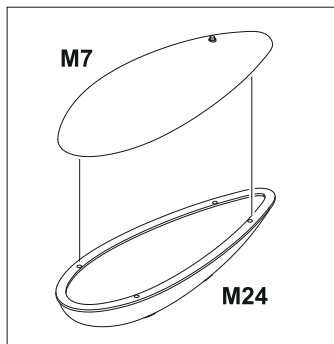
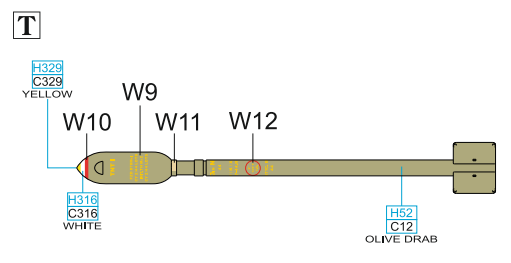
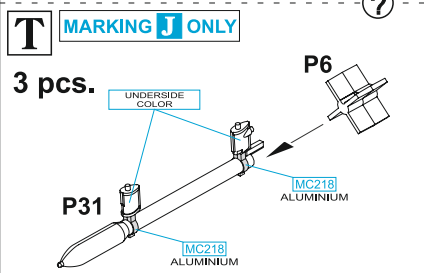
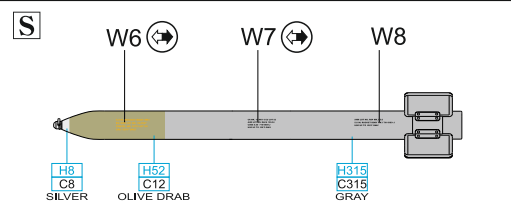
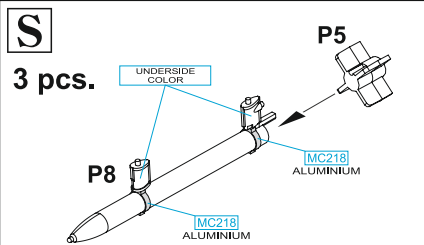

L21 2 pcs.

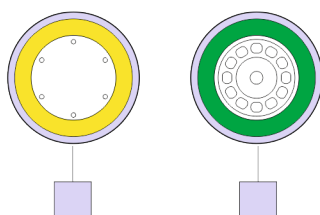

LIQUID MASK

- A19 ● A2
- A14 ● A3
- A4

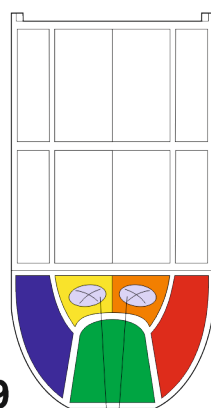
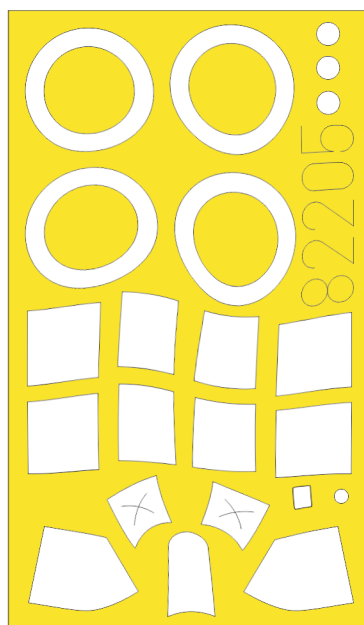
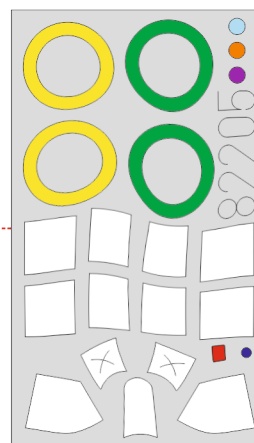

A9

LIQUID MASK ■

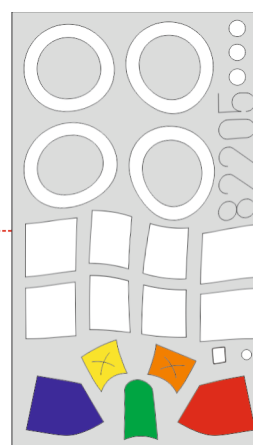

A15
 ?
 A16

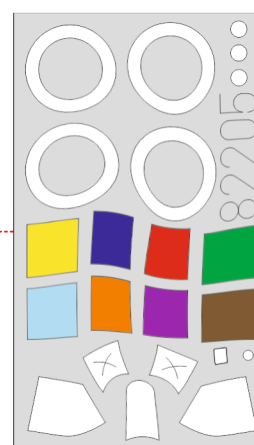
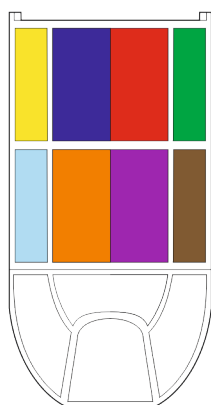

A Lt. Robert I. Myers, VC-93, USS Petrof Bay (CVE-80), April 1945

USS Petrof Bay (CVE-80), after being commissioned into the Navy in February 1944, was first engaged in shipping aircraft, material, and military personnel. In May VC-76 boarded and participated in the Peleliu landings, the Philippine Campaign, and the Battle of Iwo Jima. After the latter operation, VC-76 was replaced by a fresh unit, VC-93, with which USS Petrof Bay intervened in the Okinawa landings and subsequently supported ground forces and provided protection to vessels off that island. During this activity, the pilots of VC-93 had to face primarily kamikaze raids, and on this Wildcat, on April 6, 1945, Lt. Robert Ira Myers managed to shoot down kamikaze Zero attacking a transport ship, shortly after another Zero, and finally a D3A Val dive bomber attempting to engage a destroyer. For these achievements he was subsequently awarded the Navy Cross.

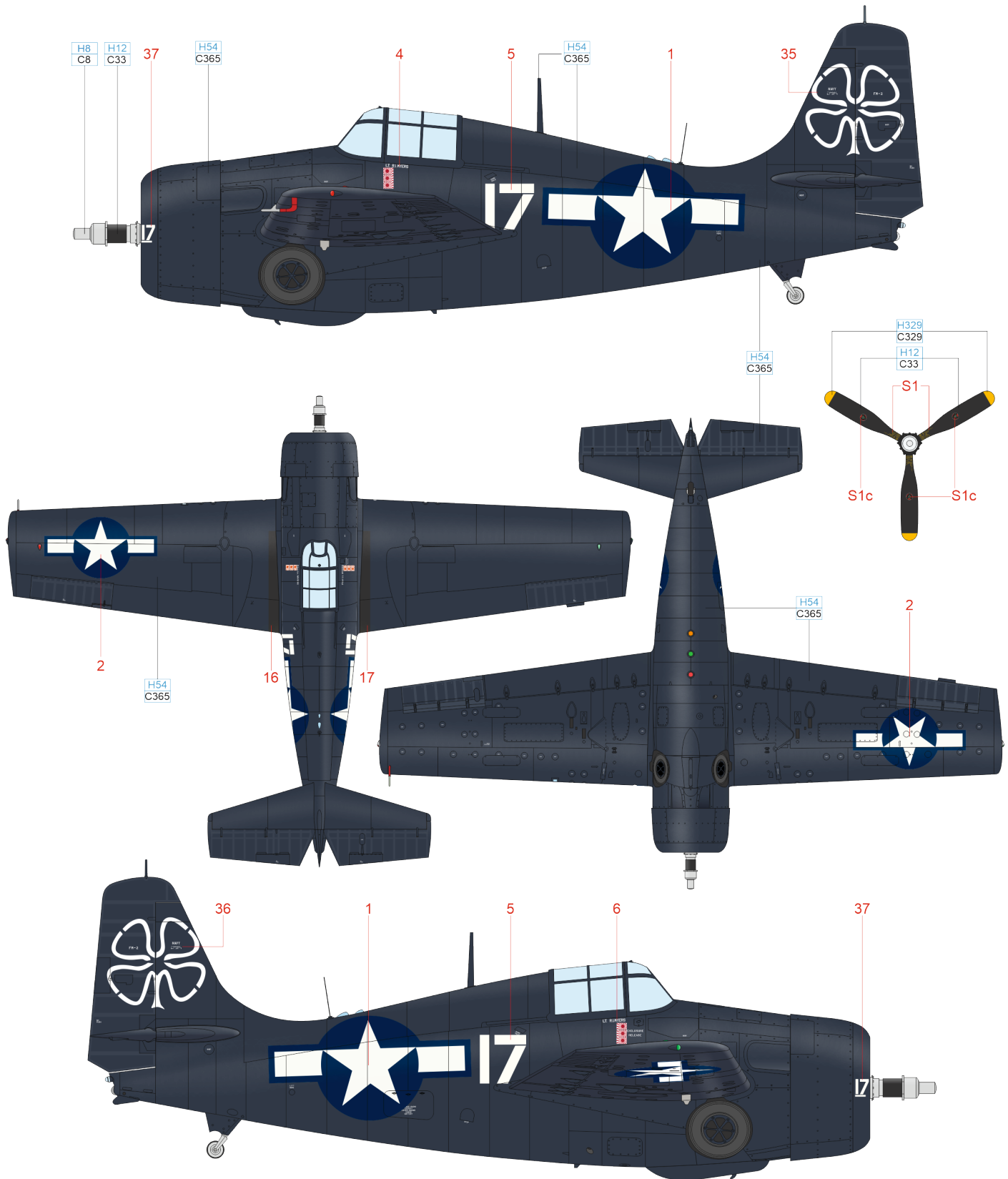

ČESKOU VERZI TEXTU NALEZNETE NA
www.eduard.com
 POD KATALOGOVÝM ČÍSLEM 82205



SILVER H8 C8 SEA BLUE H54 C365 YELLOW H329 C329 BLACK H12 C33

eduard

B VC-88, USS Saginaw Bay (CVE-82), 1945

The escort carrier Saginaw Bay (CVE-82), one of fifty Casablanca-class vessels, was commissioned on March 2, 1944, after a construction period of 123 days. Like her sister ships, she first participated in the transport of personnel, aircraft, and material, then combined squadron boarded to participate in combat operations, specifically the landings in Palau, the liberation of the Philippines, and the invasions of Iwo Jima and Okinawa. The Okinawa landings were supported from aboard the USS Saginaw Bay by VC-88 equipped with FM-2 Wildcats and TBM-3 Avengers.

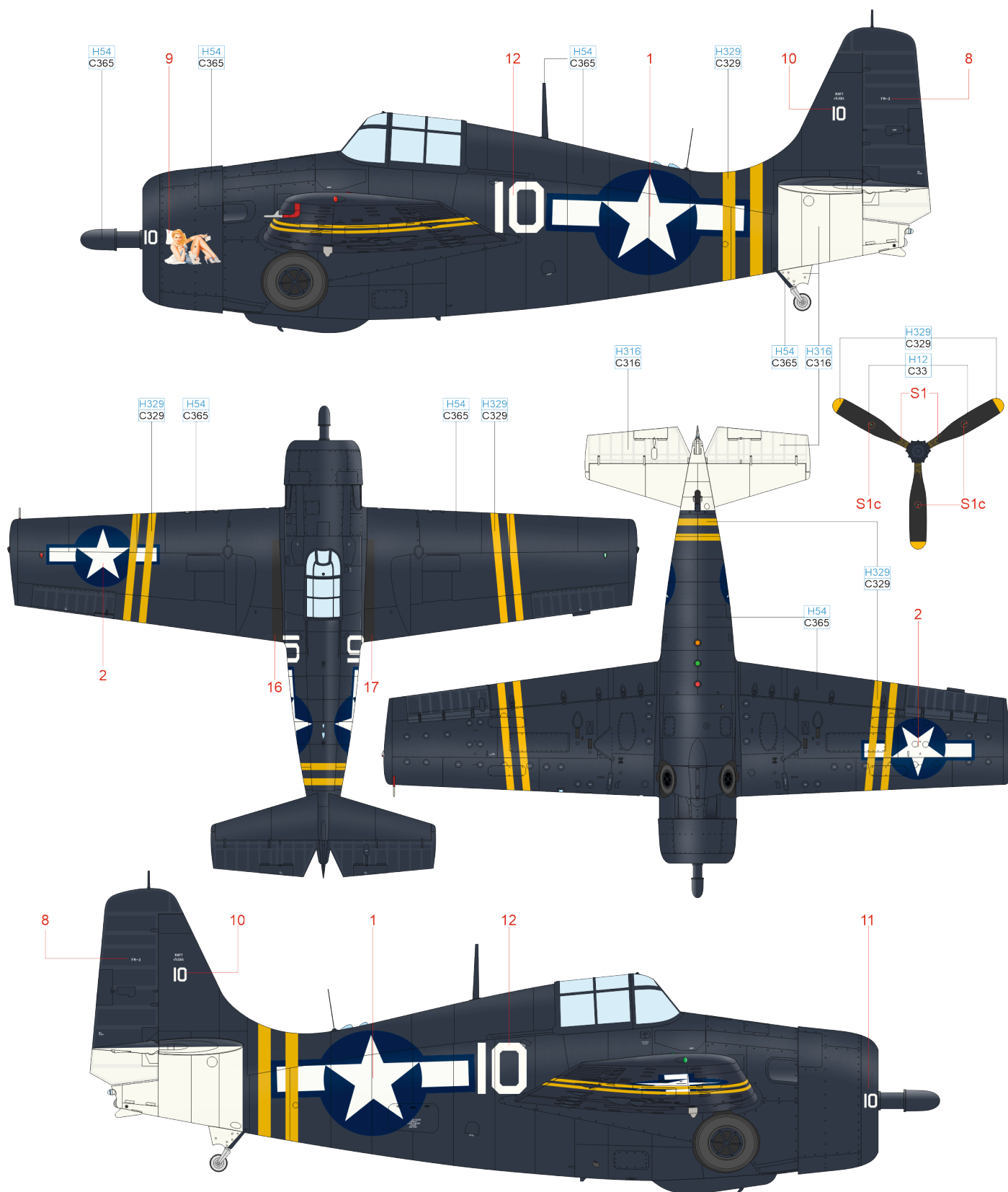

ČESKOU VERZI TEXTU NALEZNETE NA
www.eduard.com
 POD KATALOGOVÝM ČÍSLEM 82205



WHITE	H316 C316	SEA BLUE	H54 C365	YELLOW	H329 C329	BLACK	H12 C33
-------	--------------	----------	-------------	--------	--------------	-------	------------

eduard

C VC-9, USS Solomons (CVE-67), spring/summer 1944

Combined VC-9 squadron consisting of nine FM-2 Wildcats and twelve Avengers was assigned aboard USS Solomons (CVE-67), docked in Recife, Brazil. The primary mission of the ship and her unit was anti-submarine patrols in the South Atlantic. The VC-9 spent five months aboard from March to August 1944 and participated in four cruises during this period. The most successful cruise was the third one, which involved the detection and subsequent sinking of the German Type IXD2 submarine U-860 on June 15, 1944. The submarine was on her first patrol under the command of Fregatenkapitän Paul Büchel and 42 crew members followed her into the depths. Wildcats flying over the Atlantic wore the so-called Atlantic camouflage scheme, consisting of white paint on the lower and side surfaces, while the upper surfaces were camouflaged with Dark Gull Gray.

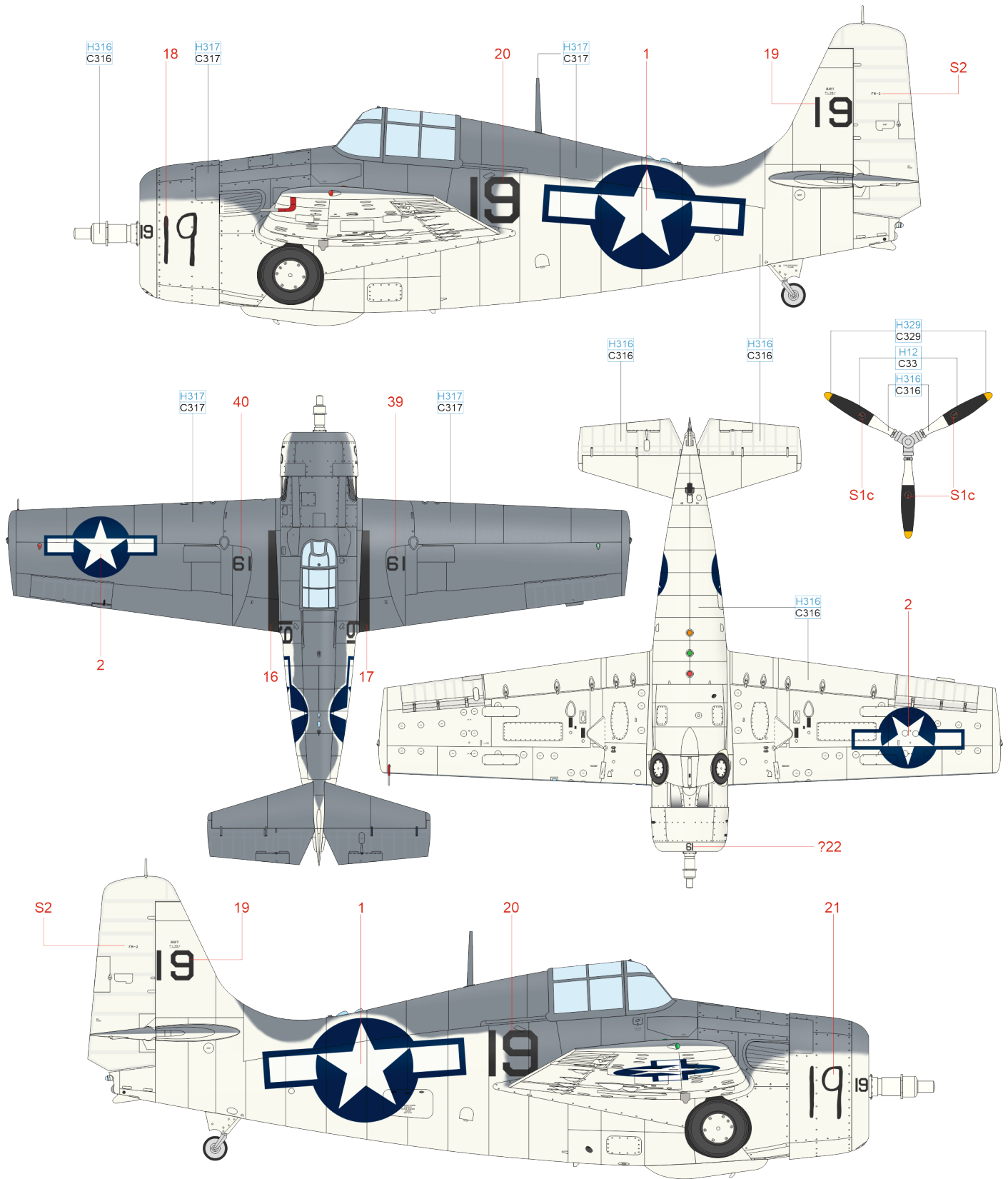

ČESKOU VERZI TEXTU NALEZNETE NA
www.eduard.com
 POD KATALOGOVÝM ČÍSLEM 82205



WHITE H316 C316 GRAY H317 C317 YELLOW H329 C329 BLACK H12 C33

eduard

D VC-99, USS Hogatt Bay (CVE-75), 1945

USS Hoggatt Bay (CVE-75), a Casablanca-class escort carrier, joined the fleet operating off Okinawa on May 8, 1945. Aboard was combined squadron VC-99 that had embarked shortly before at Saipan to support ground troops at Okinawa and to participate in fleet protection against Kamikaze raids by Japanese pilots. On June 24, the ship was released from operations off Okinawa and sent to Leyte, where she parted ways with the VC-99 awaiting rest and replenishment of losses. An all-blue camouflage scheme in Gloss Sea Blue was introduced in June 1944, replacing the three-color camouflage scheme used since January 1943.

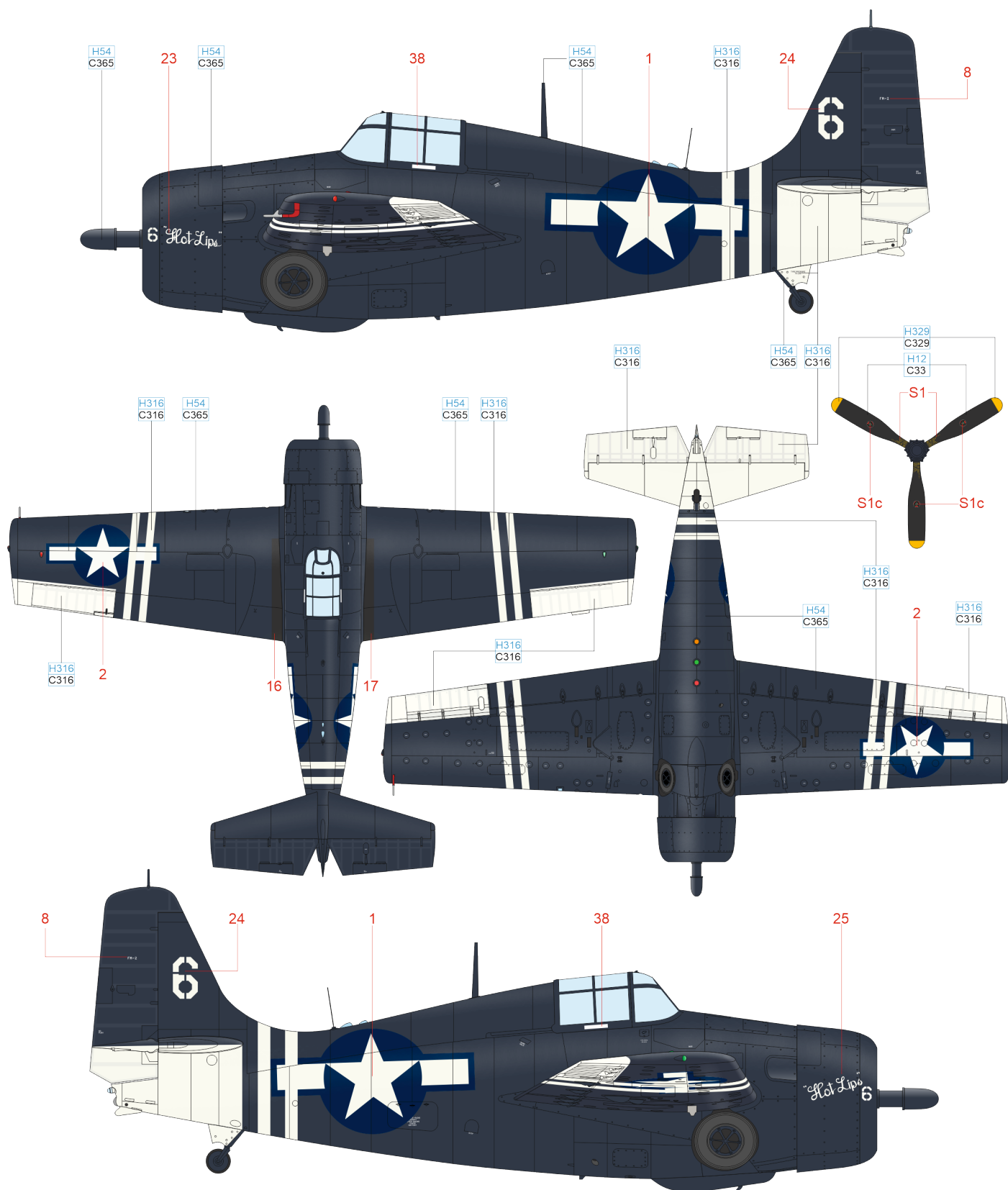

ČESKOU VERZI TEXTU NALEZNETE NA
www.eduard.com
 POD KATALOGOVÝM ČÍSLEM 82205



WHITE	H316 C316	SEA BLUE	H54 C365	YELLOW	H329 C329	BLACK	H12 C33
-------	--------------	----------	-------------	--------	--------------	-------	------------

eduard

E Lt. Martin Ferko, VC-4, USS White Plains (CVE-67), June – September 1944

Leopold Martin Ferko was born to Slovak parents on January 29, 1915, in Great Falls, Montana. He earned his bachelor's degree from Stanford University, where he was also a star of the American football team there. He then taught math and English at San Francisco High School and also coached the local football team before signing up with the Navy and beginning flight training on February 3. He then continued as an instructor at Corpus Christi, Texas, before being transferred to Pearl Harbor in June 1943, where he embarked with the VC-4 on the USS White Plains. The unit consisted of 16 FM-2s and 12 TBM Avengers. During the three days of the Battle of Leyte Gulf, he scored all five of his kills, although the first two may have been his last. After shooting down two Oscars he was in fact attacked himself and his FM-2 took one hit after another before the attacking enemy was shot down by the Ens. Pool. Ferko then had to make an emergency landing at Tacloban due to a damaged elevator. There, the aircraft was repaired, and he was able to return in time to score three more kills. Leopold Ferko retired from the Navy with the rank of Lieutenant Commander and died on May 16, 1992, in San Francisco.

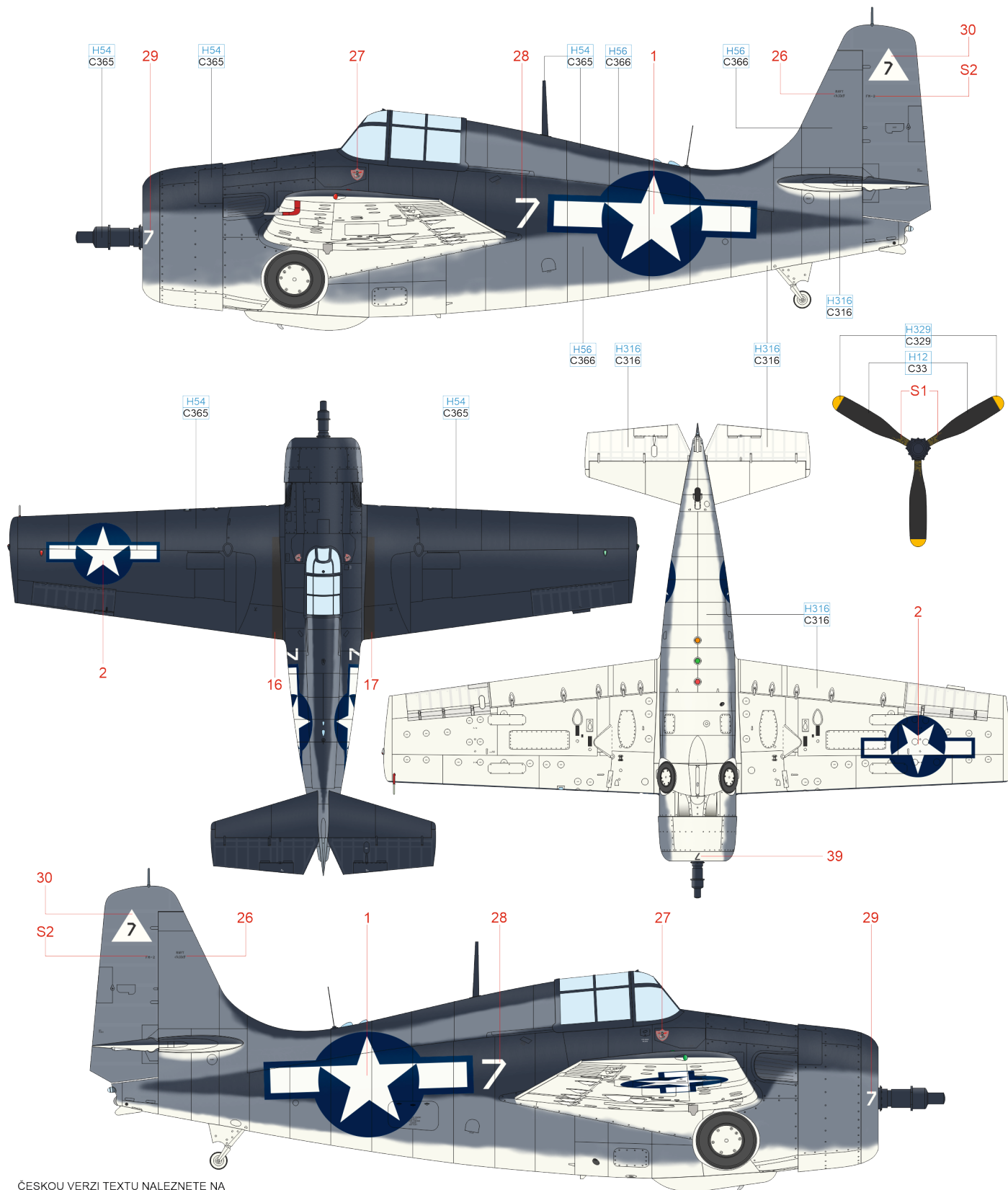

ČESKOU VERZI TEXTU NALEZNETE NA
www.eduard.com
 POD KATALOGOVÝM ČÍSLEM 82205



WHITE H316 C316 INTERMEDIATE BLUE H56 C366 YELLOW H329 C329 SEA BLUE H54 C365 BLACK H12 C33

eduard

F JV836, No. 882 Naval Air Squadron, HMS Searcher, August 1945

No. 882 NAS embarked aboard HMS Searcher in September 1943 after previous service on the carriers Illustrious and Victorious. Already on these motherships she used Martlets, as the British called Wildcats until January 1944. Aboard HMS Searcher the unit took part in major operations of the Royal Navy. These included Operation Tungsten (the attack on Tirpitz, anchored in Kaafjord) in April 1944, Operation Dragoon (the Allied landings in southern France) in August 1944, and Operation Outing (attacks on German-occupied islands in the Aegean Sea) in September of that year. This was followed by a return to the home islands, where the unit took delivery of new Wildcats VI (FM-2 Wildcat) and in February 1945 headed again aboard Searcher to the Norwegian coast, where it conducted raids on German-occupied territory. After the end of the war in Europe, it was decided that No. 882 NAS aboard Searcher would move to the Pacific to reinforce the British Pacific Fleet, but the end of the war found her enroute during a stop in Ceylon (now Sri Lanka). The all-blue Wildcats VI serving with the British Pacific Fleet had cockades painted in blue and white only. The red center was omitted because of possible confusion with the Japanese Hinomaru. At the same time, white stripes were painted on the wings and tail surfaces for easier identification of friendly aircraft.

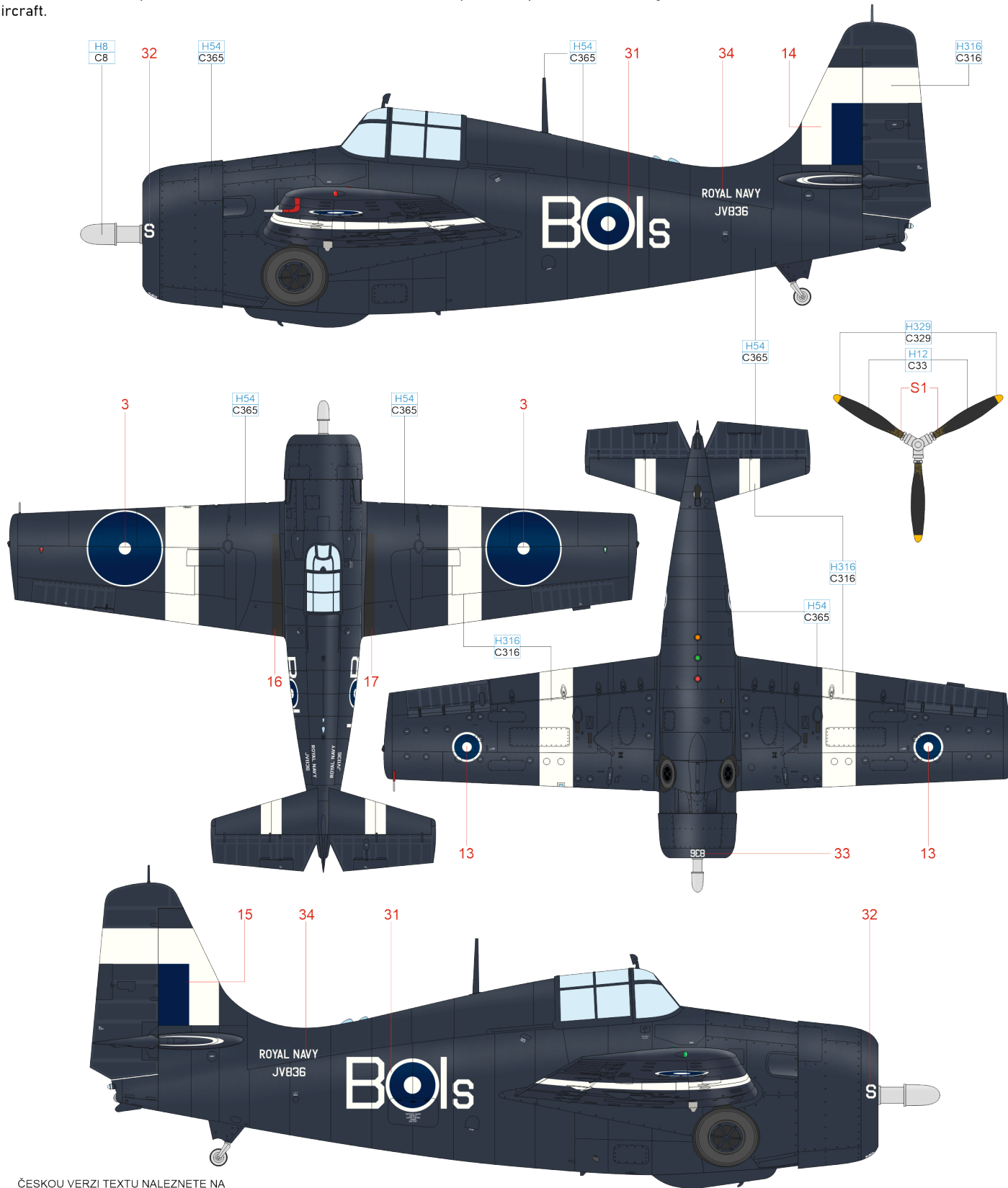

ČESKOU VERZI TEXTU NALEZNETE NA
www.eduard.com
 POD KATALOGOVÝM ČÍSLEM 82205



SILVER H8 C8 WHITE H316 C316 SEA BLUE H54 C365 YELLOW H329 C329 BLACK H12 C33

eduard

Eduard goodies for

FM-2 Wildcat 1/48

- 481119 FM-2 landing flaps (PE-set)
- 644222 FM-2 LööK (Brassin)
- 644226 FM-2 LööKplus (Brassin)
- 648886 FM-2 undercarriage legs BRONZE (Brassin)
- 648887 FM-2 wheels (Brassin)
- 648888 FM-2 seat PRINT (Brassin)
- 648889 FM-2 folding wings PRINT (Brassin)
- 648890 FM-2 gun barrels PRINT (Brassin)
- 648895 FM-2 cockpit PRINT (Brassin)
- 648896 FM-2 cockpit w/ armoured headrest PRINT (Brassin)
- 648900 FM-2 gun bays PRINT (Brassin)
- 648901 FM-2 exhausts PRINT (Brassin)
- 648956 FM-2 wheel bay PRINT (Brassin)
- 648960 FM-2 engine PRINT (Brassin)
- 3DL48128 FM-2 SPACE (3D Decal Set)
- EX965 FM-2 TFace (Mask)
- EX971 FM-2 US national insignia (Mask)

