

A6M2 Zero Type 21

eduard

1/48 Scale Plastic Model Kit

ProfiPACK
edition



item No. 82212

The Mitsubishi Zero became symbol of the Japanese air power during WWII. The nimble and agile fighter had upper hand over US aircraft at early stages of the war in Pacific theatre, but was gradually losing to its newer opponents.

The Japanese aircraft industry was oriented towards the production of aircraft built under foreign licenses in the 1920s and early 1930s. However, the armed forces, especially the Navy, with regard to the specifics of the Chinese and Pacific battlefields, came up with requirements that foreign aircraft designs did not offer.

Due to that, Mitsubishi Heavy Industries developed Type 96 naval fighter aircraft, better known as the A5M „Claude“. The head of the design team was a young Japanese engineer, Jirō Horikoshi. With an engine that lacked some power, he managed to design a light and fast fighter with a fixed landing gear, which had no comparison in the world regarding maximum speed.

In October 1937, Mitsubishi and Nakajima were approached to develop prototype 12-shi Carrier-based Fighter. The requirements were so extreme and in some cases contradictory that the two design teams investigated whether they could be less stringent. Nakajima eventually withdrew from the project, while the criteria for the prototype were even risen based on experience on the Chinese battlefield.

In the end, Horikoshi's team managed to meet the technical specifications, not only thanks to the aerodynamic design and a new type of light alloy used for the aircraft's skin, but also thanks to the Nakajima Sakae 11 engine. During the flight tests, the wing surface suffered cracking during overload and aileron control during high-speed maneuvers had to be addressed. The new fighter had a powerful armament of two cannons and two machine guns, extremely long range (over 1,800 km) and excellent maneuverability. The new fighter reached top speed of 533 km/h at an altitude of 4,550 m. However, it lacked armor and other protective features and had structural speed limit 600 km/h.

Surprising Zero

The new aircraft entered service in 1940 with 940hp engine Sakae 12 and received the official designation Rei shiki Kanjō sentōki (Type 0 carrier fighter), with the „zero“ being derived from the imperial year 2600 (1940). Japanese pilots usually abbreviated it as „Rei-Sen“. That was also the origin of the name „Zero“ often used by Allied pilots instead of the official code name, derived from the male name „Zeke“. As part of the Navy's system, the new machine was given the type designation A6M, where A6 meant that it was the sixth type of carrier fighter to enter service, and M stood for the Mitsubishi company name. Zeros, specifically the A6M2 Type 11, had been successfully deployed on the Chinese battlefield since the summer of 1940, but their existence eluded Western intelligence because no one wanted to believe reports from China that suggested the Japanese had a world-class fighter. Further modifications to its design were made during 1941, creating the A6M2 Type 21.

Total of 740 A6M2 aircraft were produced by Mitsubishi by June 1942 with additional 800 delivered by Nakajima by February 1944. The gun armament was improved and variants with magazines for up to 150 rounds could be used on the Type 21.

Further development

The Nakajima company produced 254 A6M2 fighters in the float version from December 1941 to July 1943. Its prototype flew on December 8, 1941, and the design featured a pylon with a central float, a solution not used in any country up to that time. The A6M2-N fighters were mainly used to defend naval bases.

Mitsubishi began mass-producing Zeros in 1942 with the Sakae 21 engine with a two-stage compressor and output 1,130 hp. The wingspan was shortened, and the modified version was designated A6M3 Type 32. The speed limit was raised but the range was reduced, therefore only 340 of this type were produced from June to December 1942. The Allies at first believed that this was a new type of fighter. Therefore, they gave it a separate codename „Hap“, later changed to „Hamp“.

After the Allied landings on Guadalcanal, the IJN fighter units came up with a request for a Zero with the Sakae 21 engine, but with the range comparable to A6M2.

Designers at Mitsubishi modified the wing including design of fuel tanks. The wing looked similar to the one of Type 21, but the range was even 100 miles longer. This version was designated A6M3 Type 22, the extended gun barrels planes were designated Type 22a.

Another version was the Type 52 with shortened wing-span. Production began in early 1944 and Type 52 was very similar to the Type 22a. Soon the exhaust system was modified to help increase the speed of the aircraft. The Type 52a had enlarged cannons ammunition supply of 125 rounds per weapon. The Type 52b saw the installation of a 13.2 mm machine gun on the right side of the fuselage. For the Type 52c, two 13.2 mm machine guns were fitted in the wing and the 7.7 mm machine gun on the left side of the fuselage was deleted. Eight racks for small-calibre bombs or rockets were added to the wing. For night-fighting purposes, a forward-firing cannon in the fuselage behind the cockpit was installed in some Zeros, designated as A6M5-S. In total, Mitsubishi and Nakajima produced more than 5,000 A6M5s.

The last combat-deployed variant of the Zero was an aircraft with a reinforced structure for dive bomber purpose (Type 62). Later, the A6M7 was equipped with the Sakae 31 engine producing 1,130 hp. This fighter-bomber variant was designated as Type 63.

Several hundred aircraft were also modified from the A6M2 Zero Type 21 and A6M5 Type 52 to the two-seaters A6M2-K and A6M5-K, produced from January 1943 and May 1944 respectively.

The kit: A6M2 Zero Type 21

The Type 21 was direct development of the Type 11. There were several changes, the most visible of them being folding wing tips to enable easier handling on the deck of aircraft carriers. With the A6M2 Type 21 modified this way, Japan entered the war with the US and other Western nations. Mitsubishi needed to produce other aircraft in addition to the Zero, so the Nakajima company also began licensed production in late 1941.

ATTENTION



UPOZORNĚNÍ



ACHTUNG



ATTENTION



注意



Carefully read instruction sheet before assembling. When you use glue or paint, do not use near open flame and use in well ventilated room. Keep out of reach of small children. Children must not be allowed to suck any part, or pull vinyl bag over the head.



Před započítím stavby si pečlivě prostudujte stavební návod. Při používání barev a lepidel pracujte v dobře větrané místnosti. Lepidla ani barvy nepoužívejte v blízkosti otevřeného ohně. Model není určen malým dětem, mohlo by dojít k požití drobných dílů.

INSTRUCTION SIGNS * INSTR. SYMBOLS * INSTRUKTION SINNBILDEN * SYMBOLES * 記号の説明

OPTIONAL
VOLBABEND
OHNOUTSAND
BROUSITOPEN HOLE
VYVRTAT OTVORSYMETRICAL ASSEMBLY
SYMETRICKÁ MONTÁŽREMOVE
ODŘÍZNOUTREVERSE SIDE
OTOČITAPPLY EDUARD MASK
AND PAINT
POUŽIT EDUARD MASK
NABARVIT

PARTS



DÍLY



TEILE



PIÈCES



部品

PLASTIC PARTS

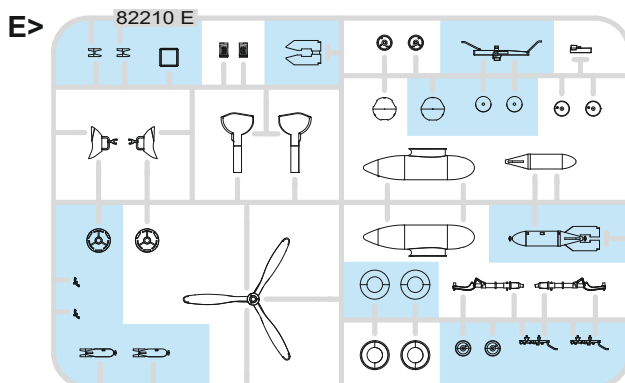
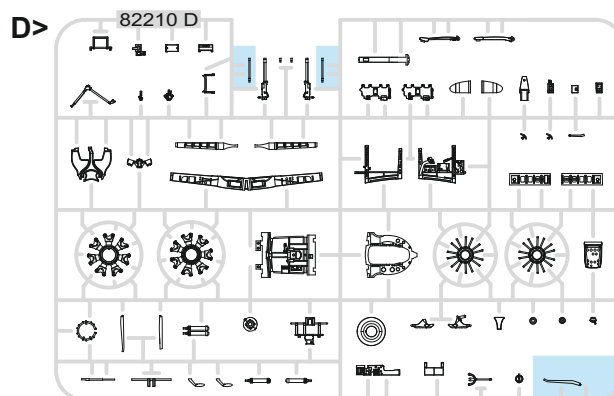
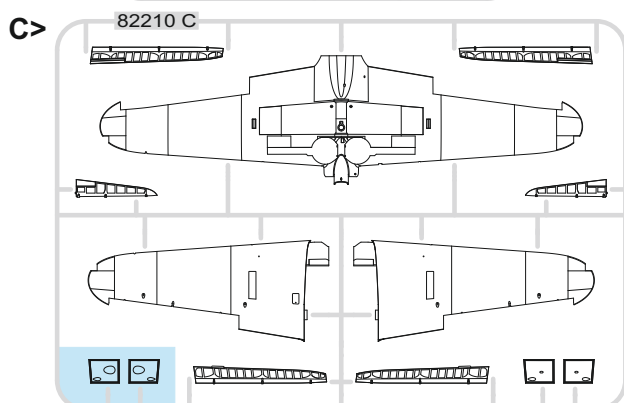
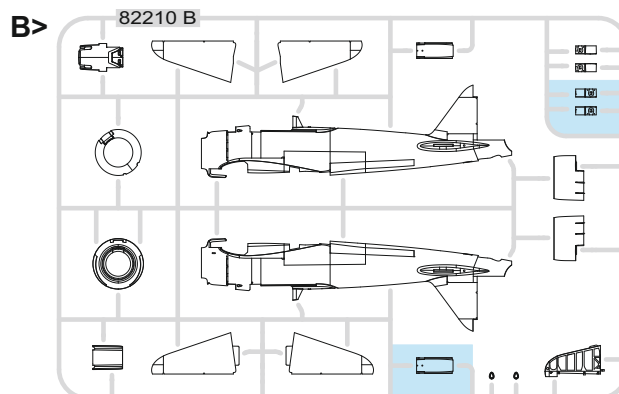
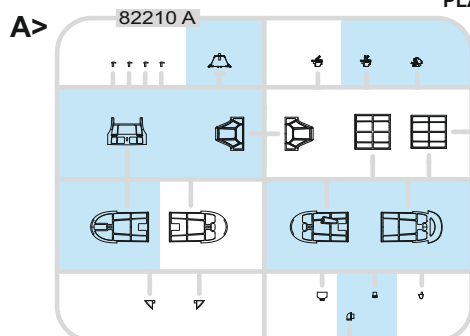

PE - PHOTO ETCHED DETAIL PARTS

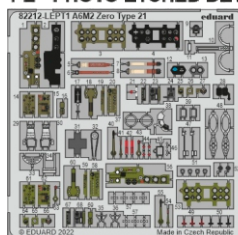
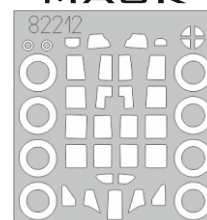
eduard
MASK

-Parts not for use. -Teile werden nicht verwendet. -Pièces à ne pas utiliser. -Tyto díly nepoužívejte při stavbě. - 使用しない部品

COLOURS



BARVY



FARBEN



PEINTURE



色

GSI Creos (GUNZE)		MISSION MODELS	
AQUEOUS	Mr.COLOR	PAINTS	
H2	C2	MMP-047	BLACK
H6	C6	MMP-004	GREEN
H8	C8		SILVER
H11	C62	MMP-001	FLAT WHITE
H12	C33	MMP-047	FLAT BLACK
H24	C58		ORANGE YELLOW
H25	C34		SKY BLUE
H47	C41	MMP-012	RED BROWN
H58	C351	MMP-059	INTERIOR GREEN
H59	C15		IJN GREEN
H63	C57		METALLIC BLUE GREEN
H70	C60	MMP-056	GRAY
H77	C137	MMP-040	TIRE BLACK
H90	C47		CLEAR RED

GSI Creos (GUNZE)		MISSION MODELS	
AQUEOUS	Mr.COLOR	PAINTS	
H93	C50		CLEAR BLUE
H327	C327	MMP-101	RED
H336	C336		HEMP
H340	C340		FIELD GREEN
H417	C117	MMP-051	RLM76 LIGHT BLUE
	C125	MMP-108	COWLING COLOR
	C131	MMP-115	RED BROWN
Mr.METAL COLOR		METALLICS	
	MC214	MMM-001	DARK IRON
	MC218	MMM-003	ALUMINIUM
	MC219	MMM-009	BRASS
Mr.COLOR SUPER METALLIC		METALLICS	
	SM201	MMC-001	SUPER FINE SILVER

1 = **H58 MMP C351 059 INT. GREEN** - MARKINGS **A; B**
F342 C340 FIELD GREEN - MARKINGS **C; D; E**

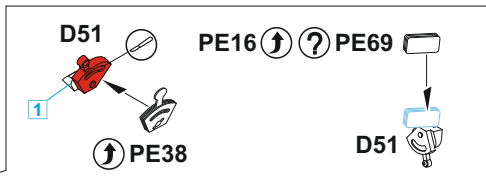
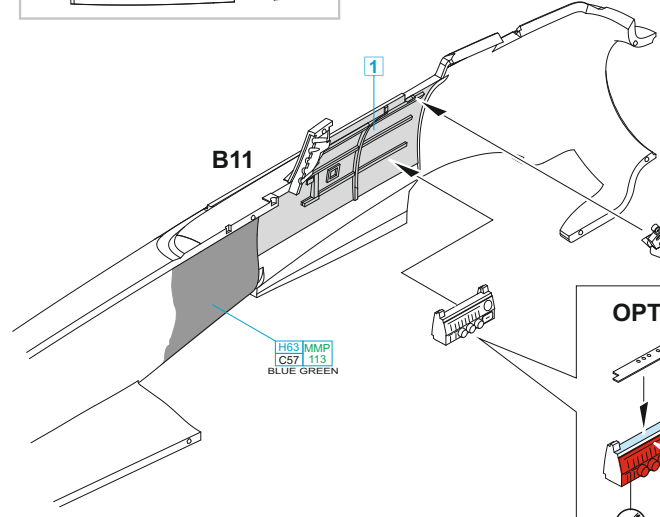
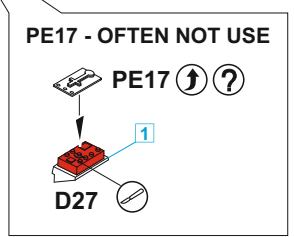
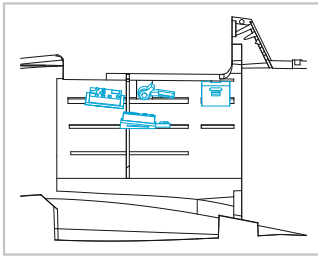
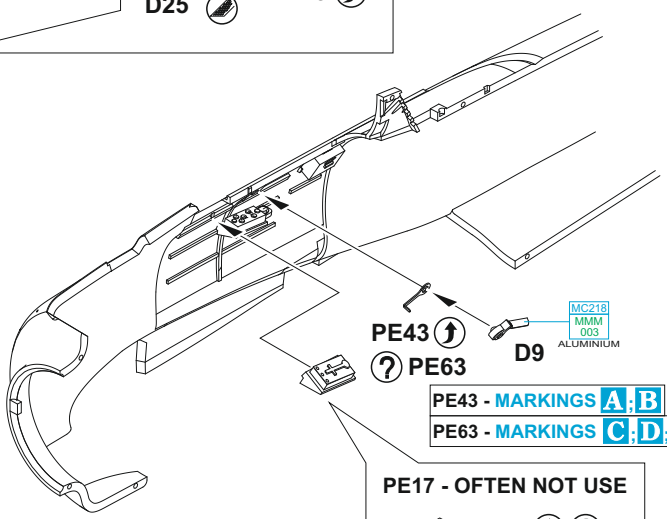
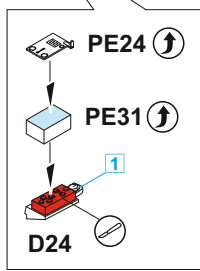
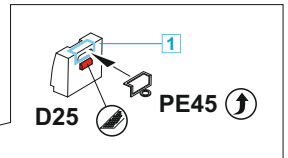
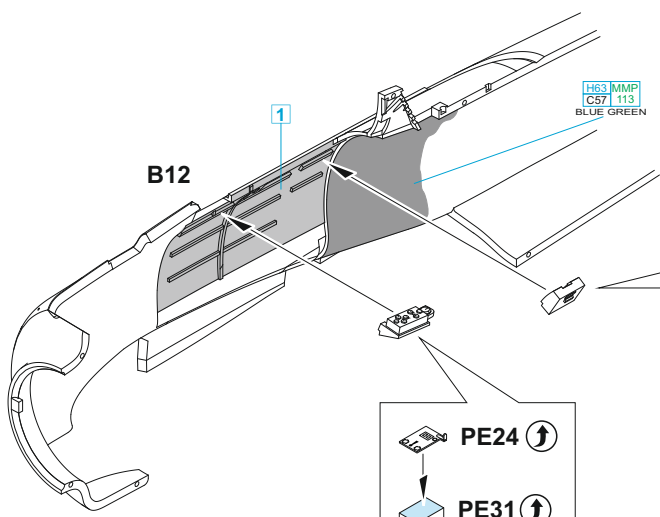

PE16, 19, 20 - MARKINGS **A; B**
PE58, 59, 69 - MARKINGS **C; D; E**

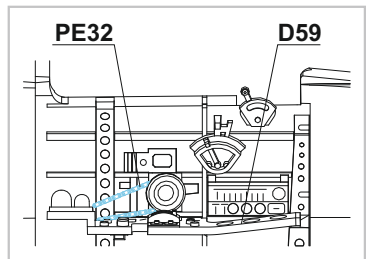
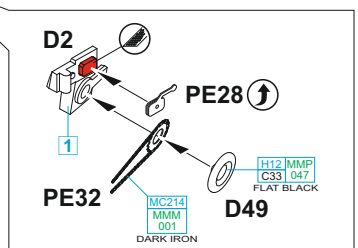
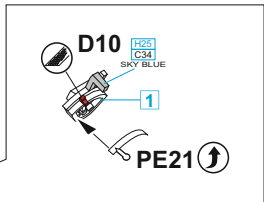
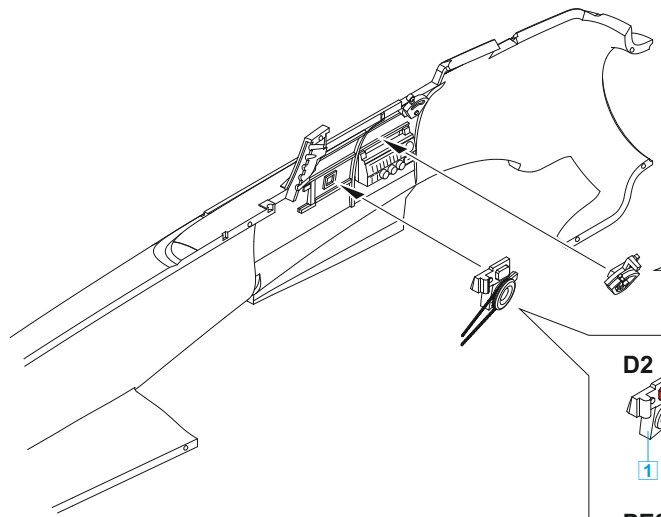
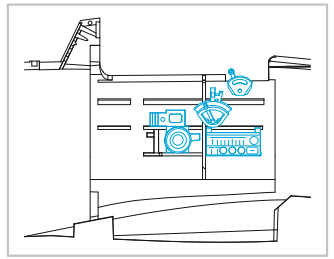
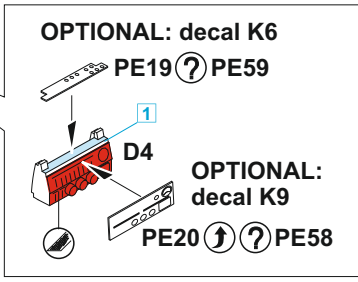

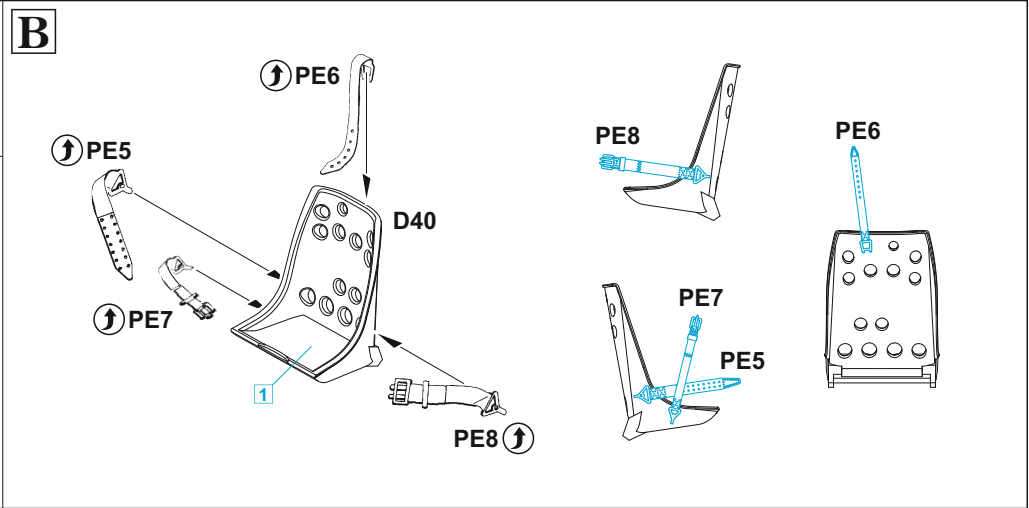
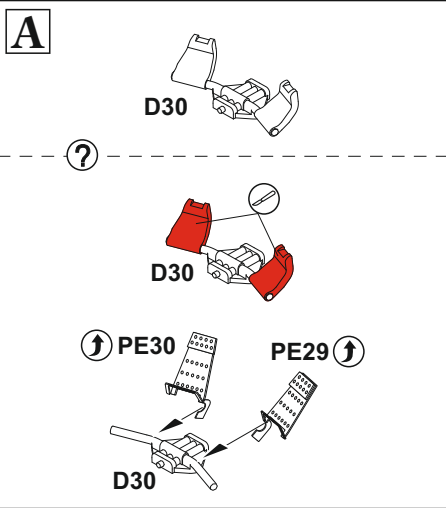

2 = H63 MMP
C57 113
BLUE GREEN - MARKINGS **A; B**

H12 MMP
C33 047
FLAT BLACK - MARKINGS **C; D; E**

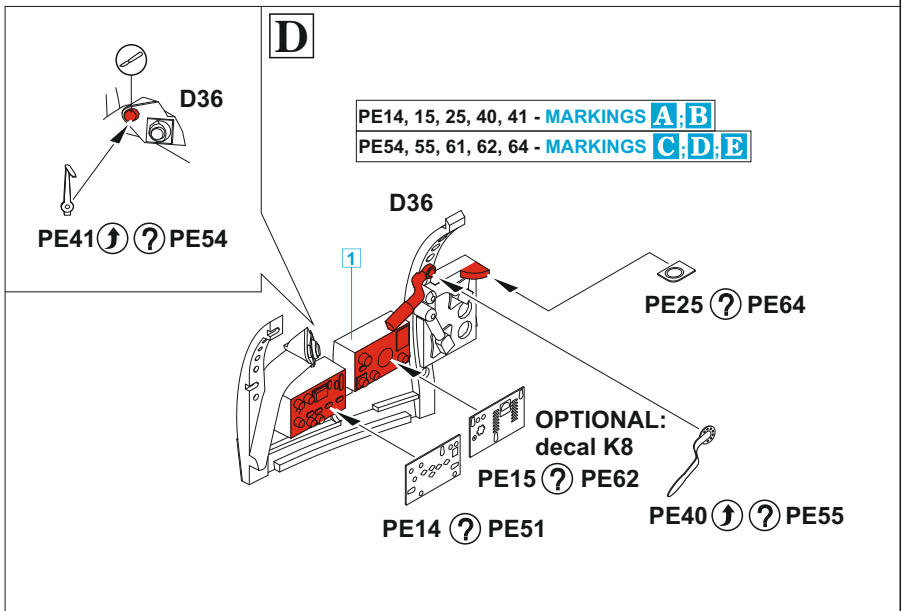
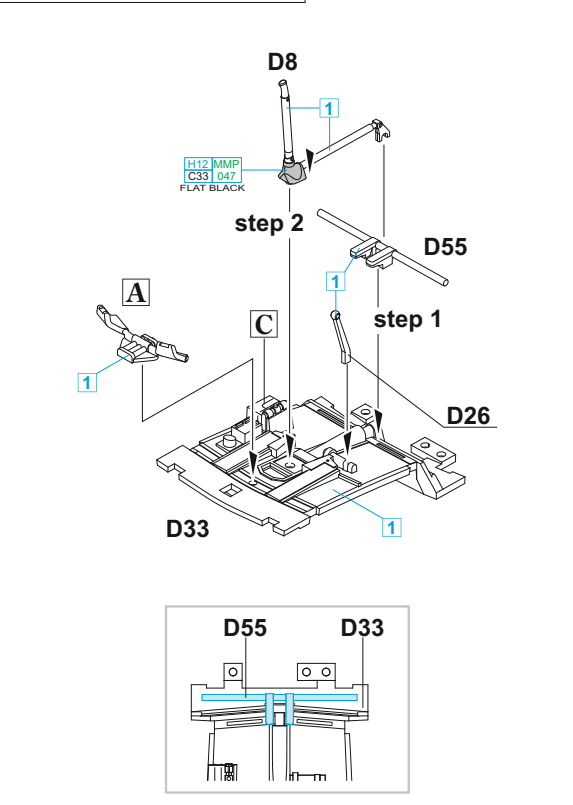
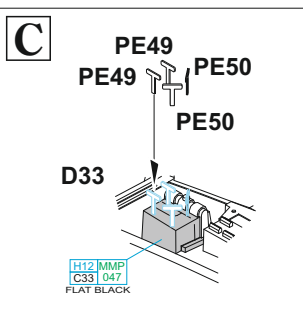
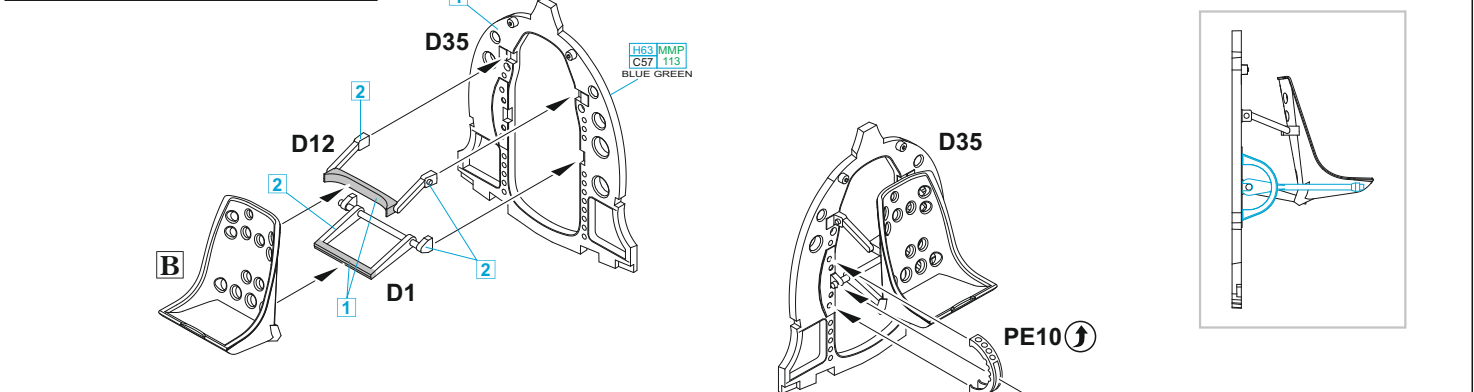

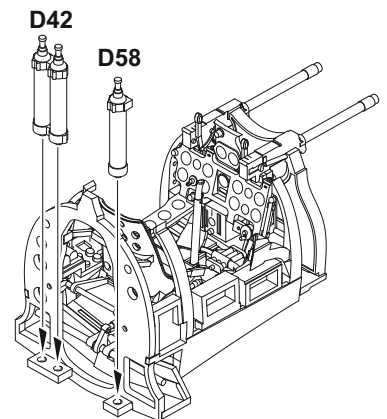
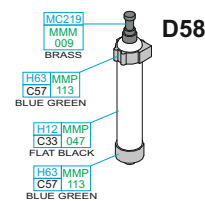
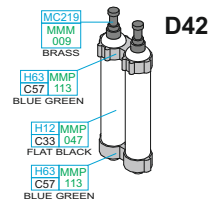
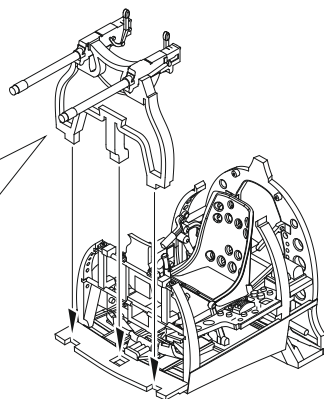
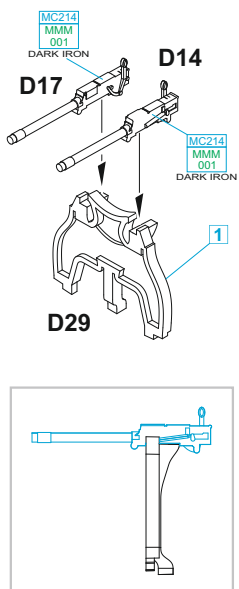
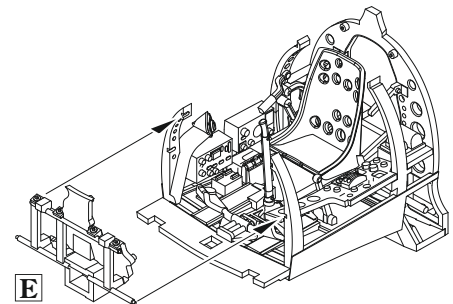
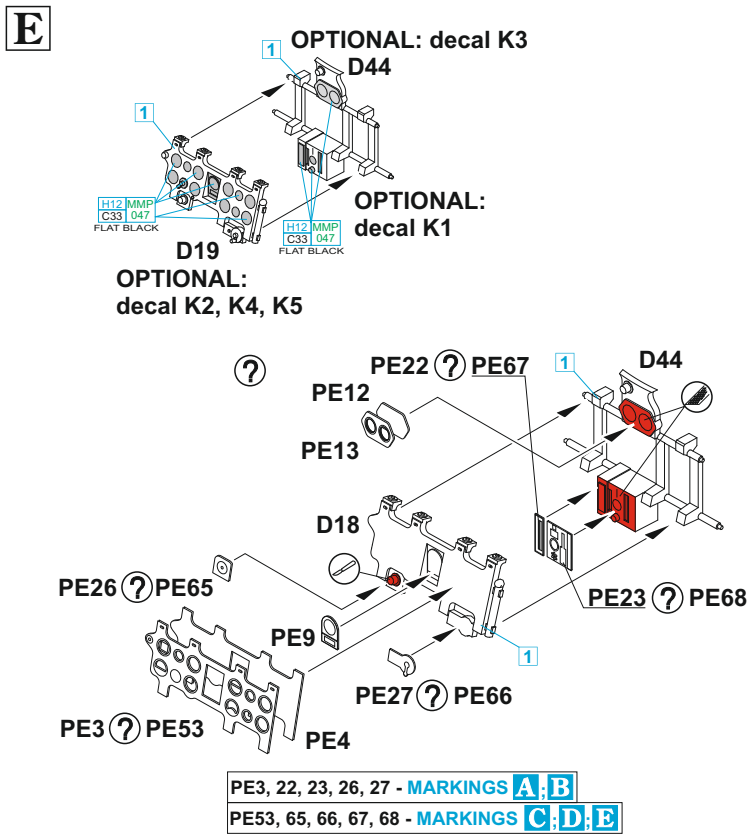
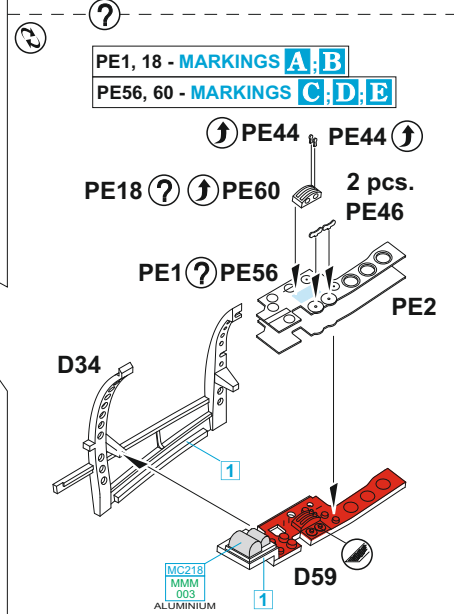
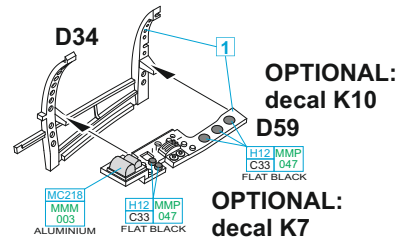
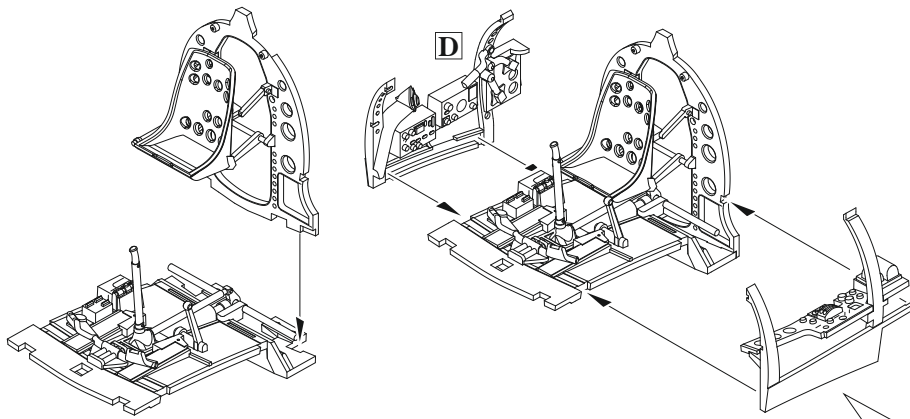

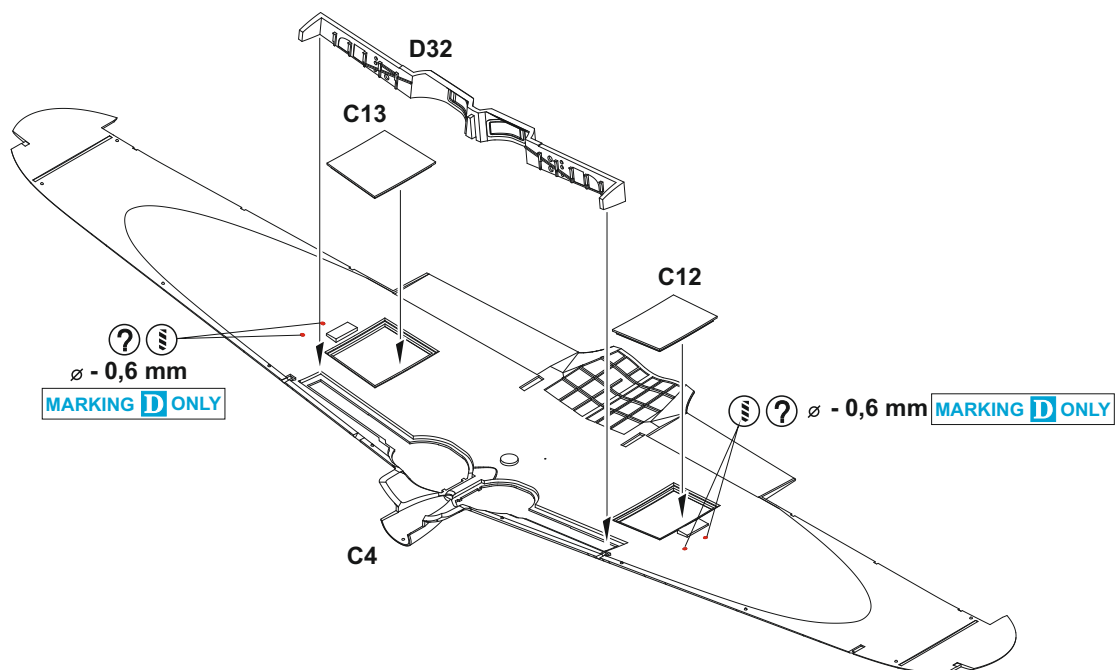
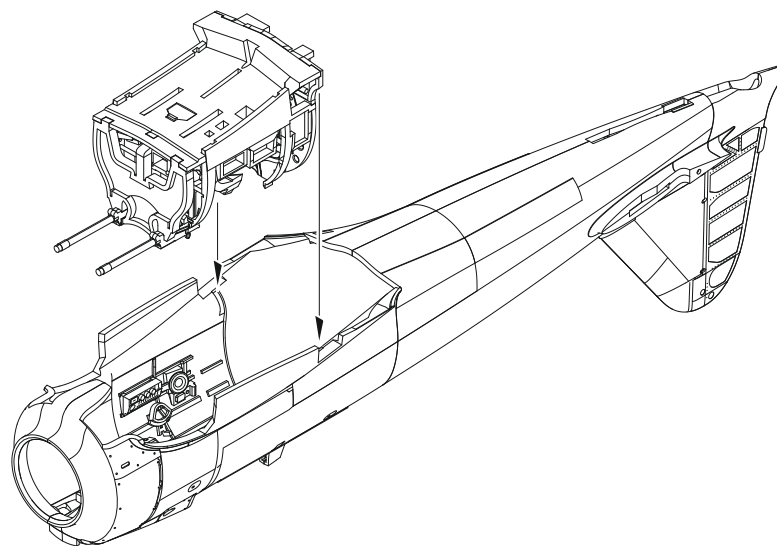
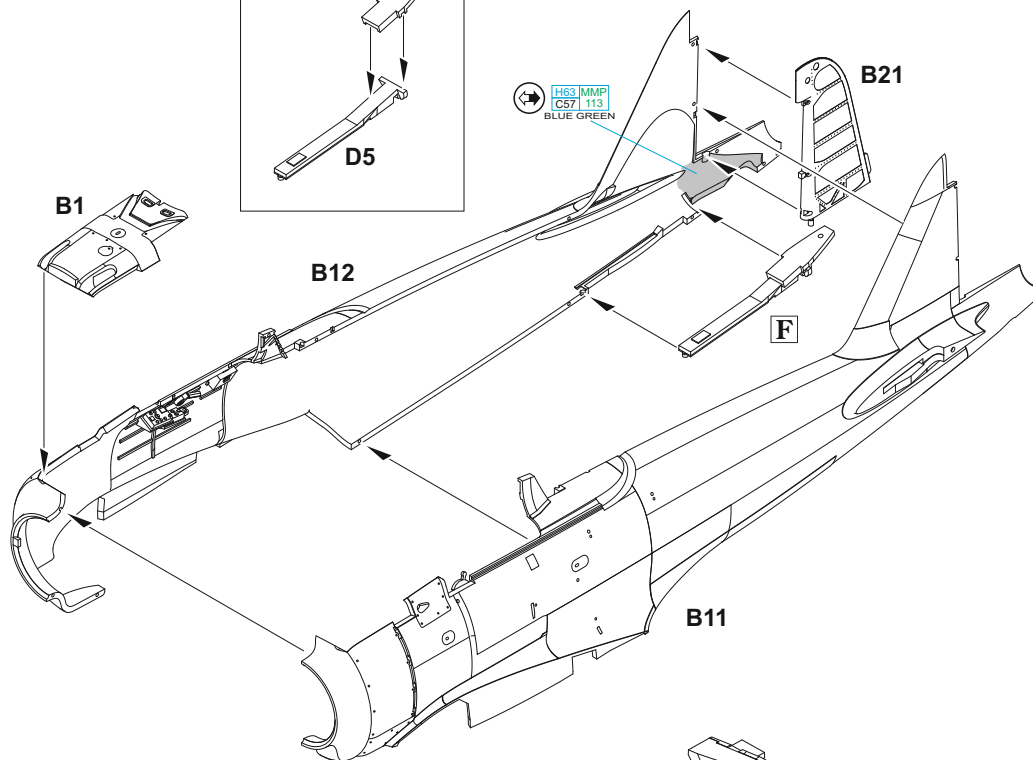
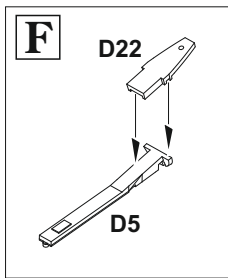

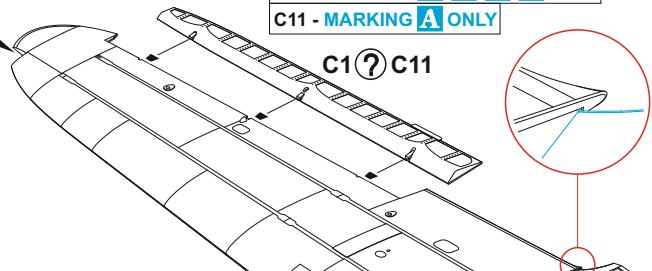
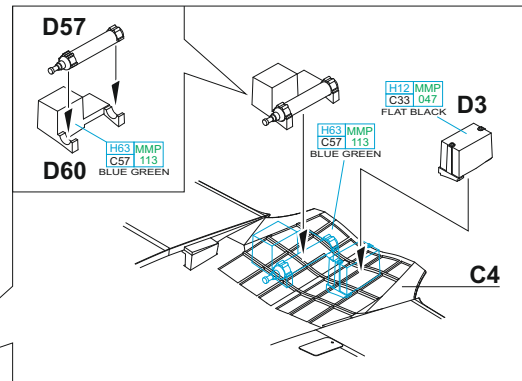
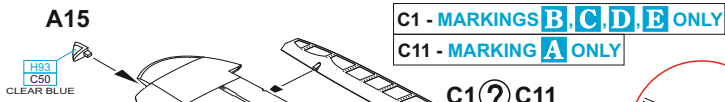
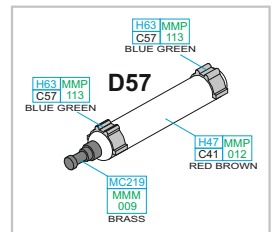
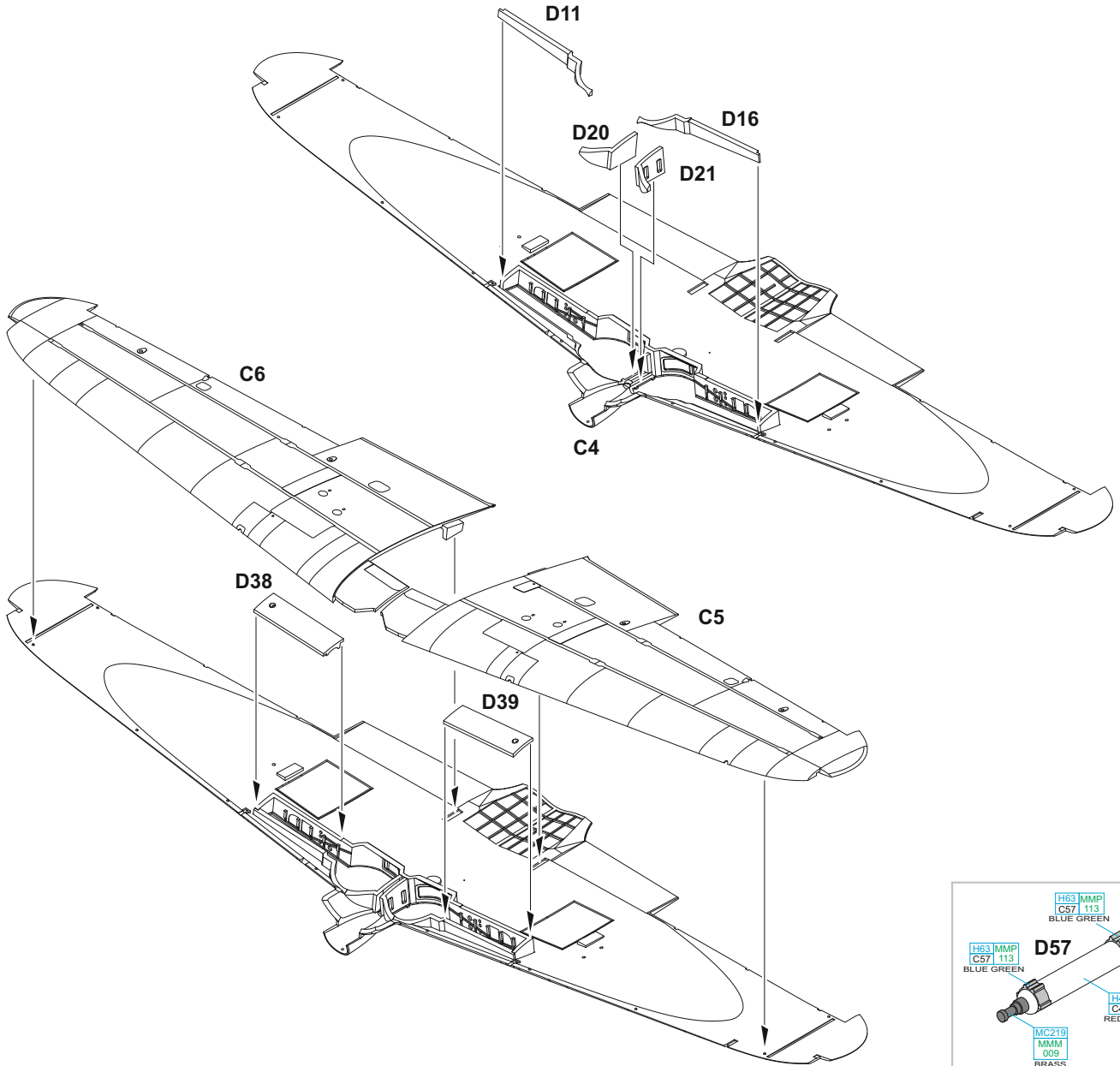

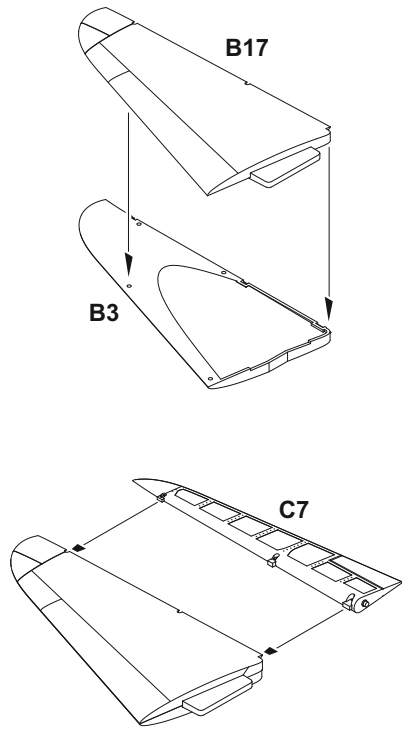
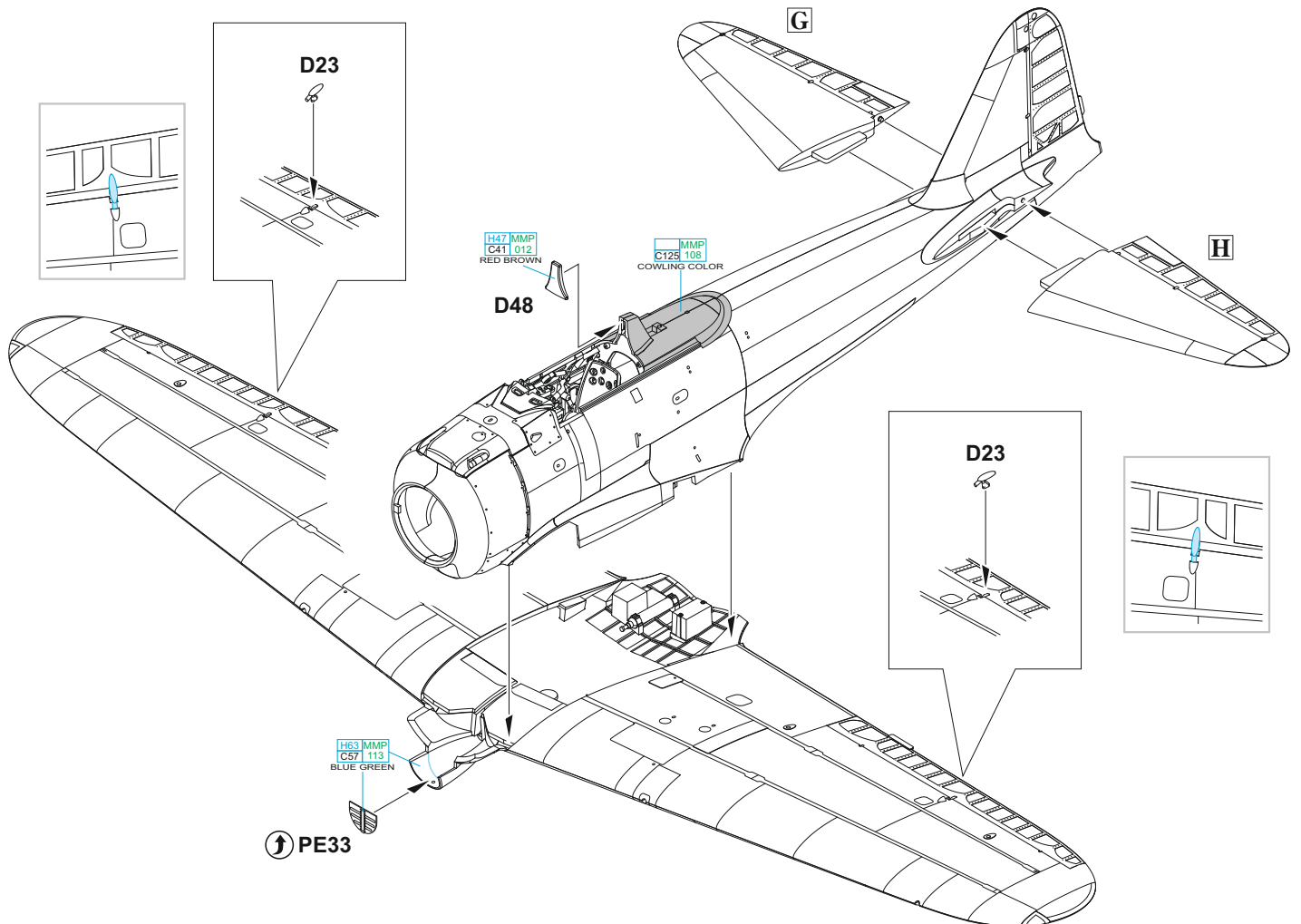
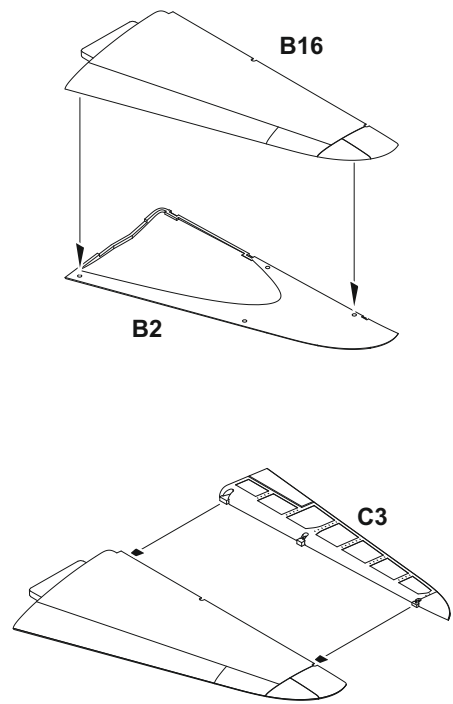
G**H**

I

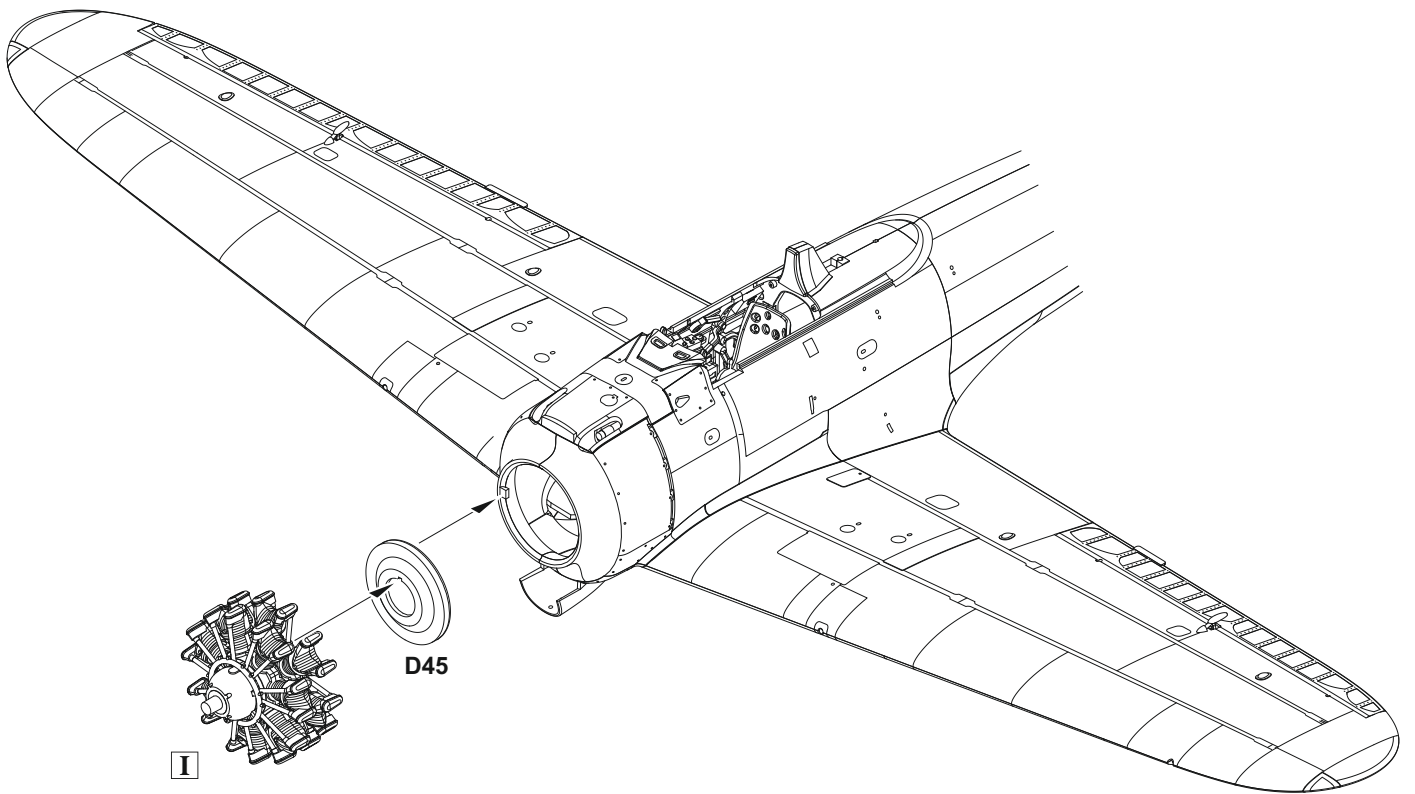
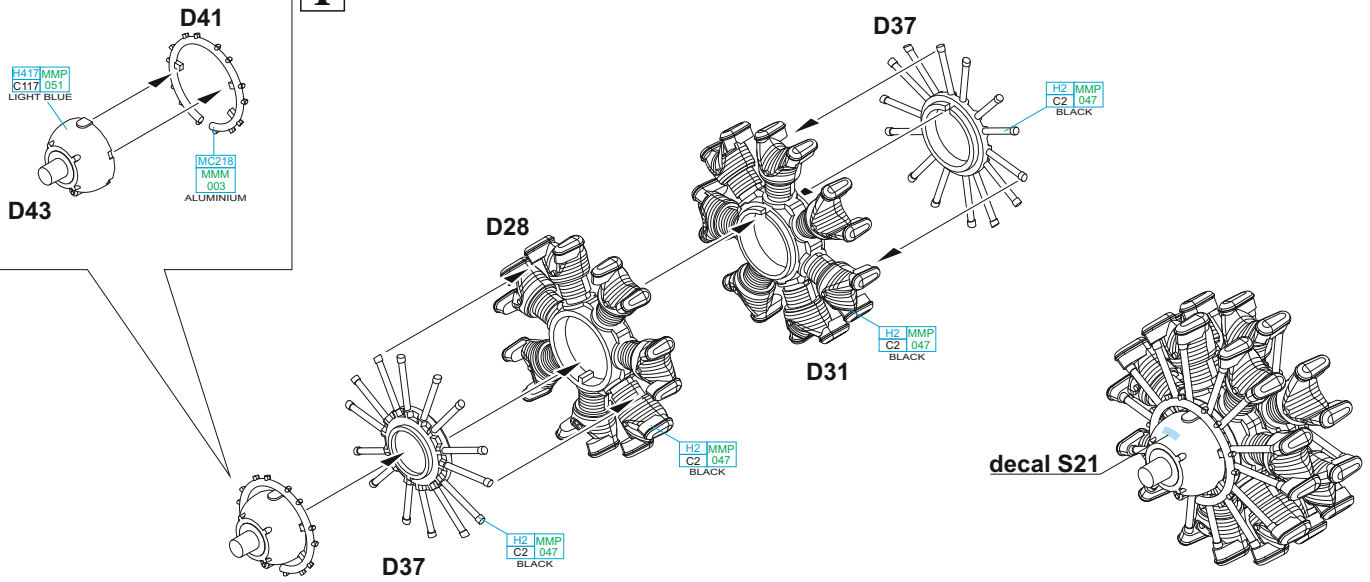

J ? MARKING E ONLY

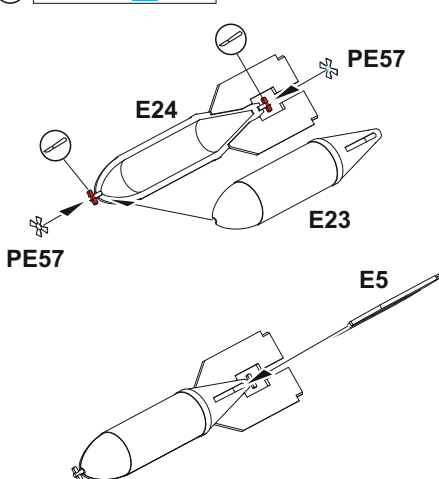

K ? MARKING D ONLY

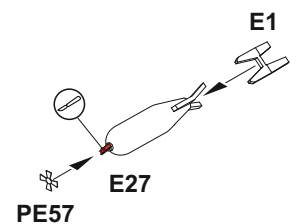

L

DO NOT GLUE!

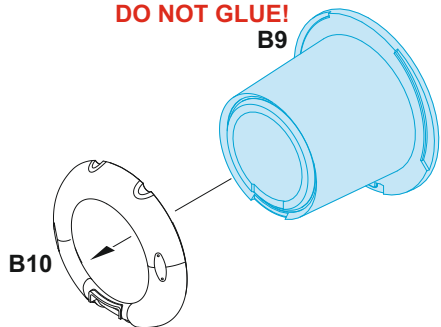

B13

DO NOT GLUE!

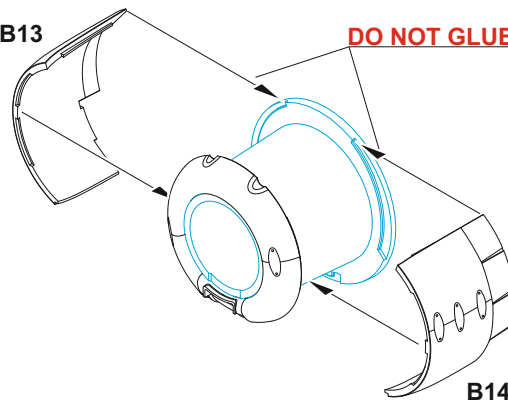

B4

DO NOT GLUE!

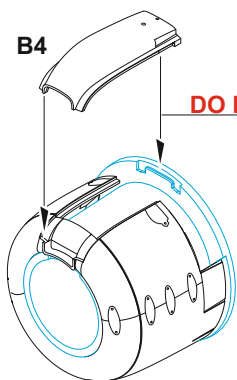

step 2

B15

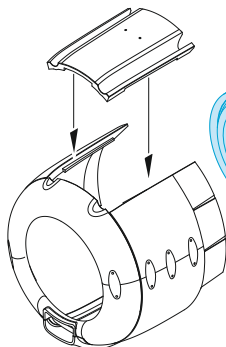

step 1

B9

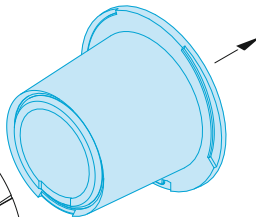

B19

MC214
MMM
001
DARK IRON

B6



B20

MC214
MMM
001
DARK IRON

B5

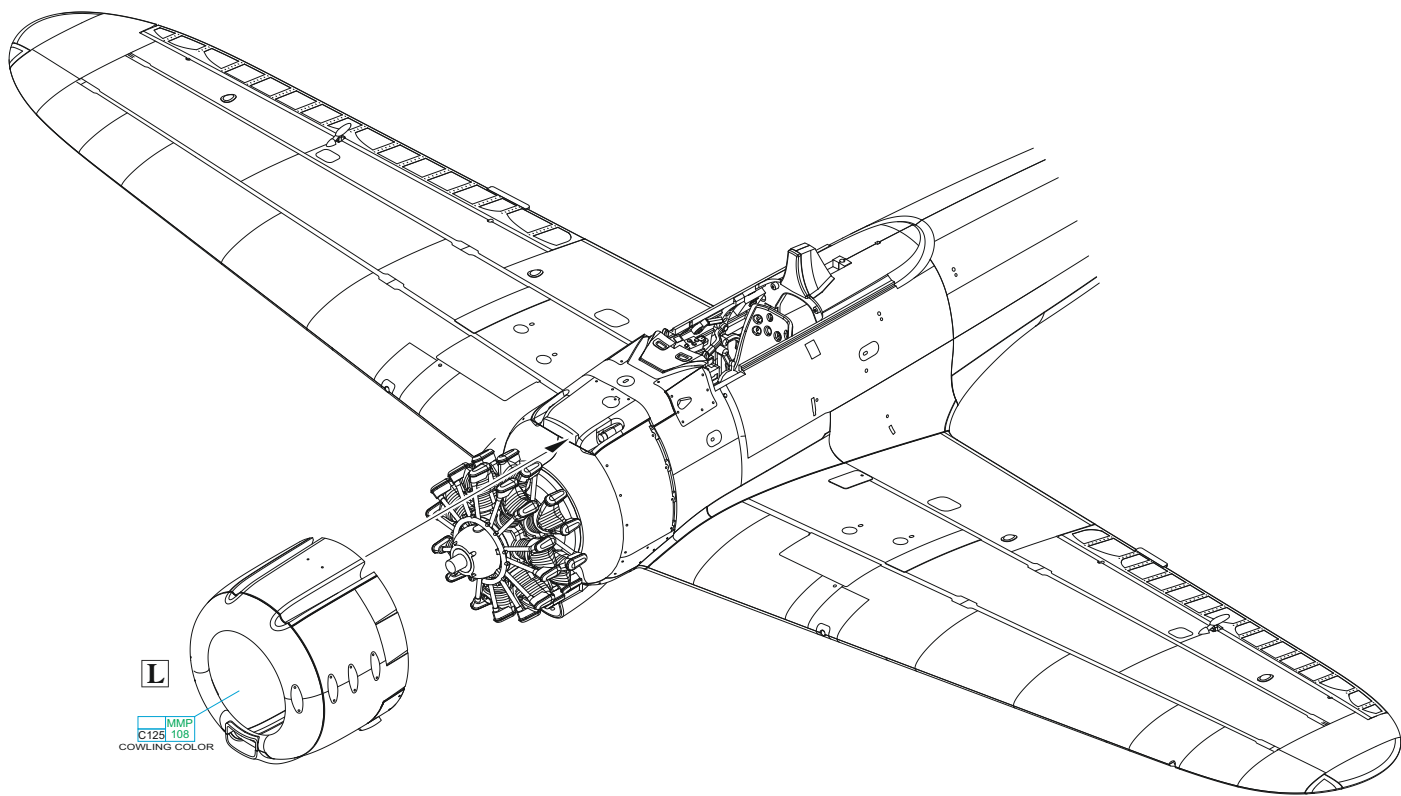
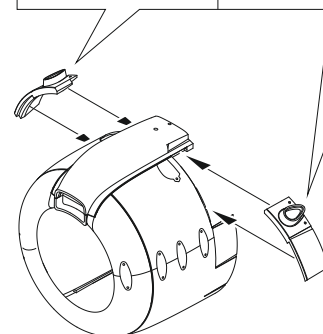

L

MMPI
C125
108
COWLING COLOR

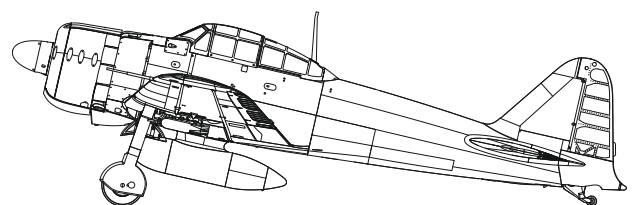
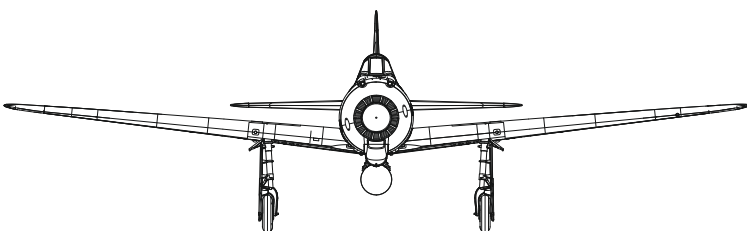
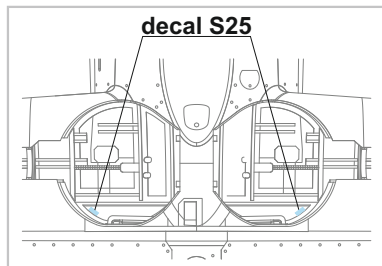
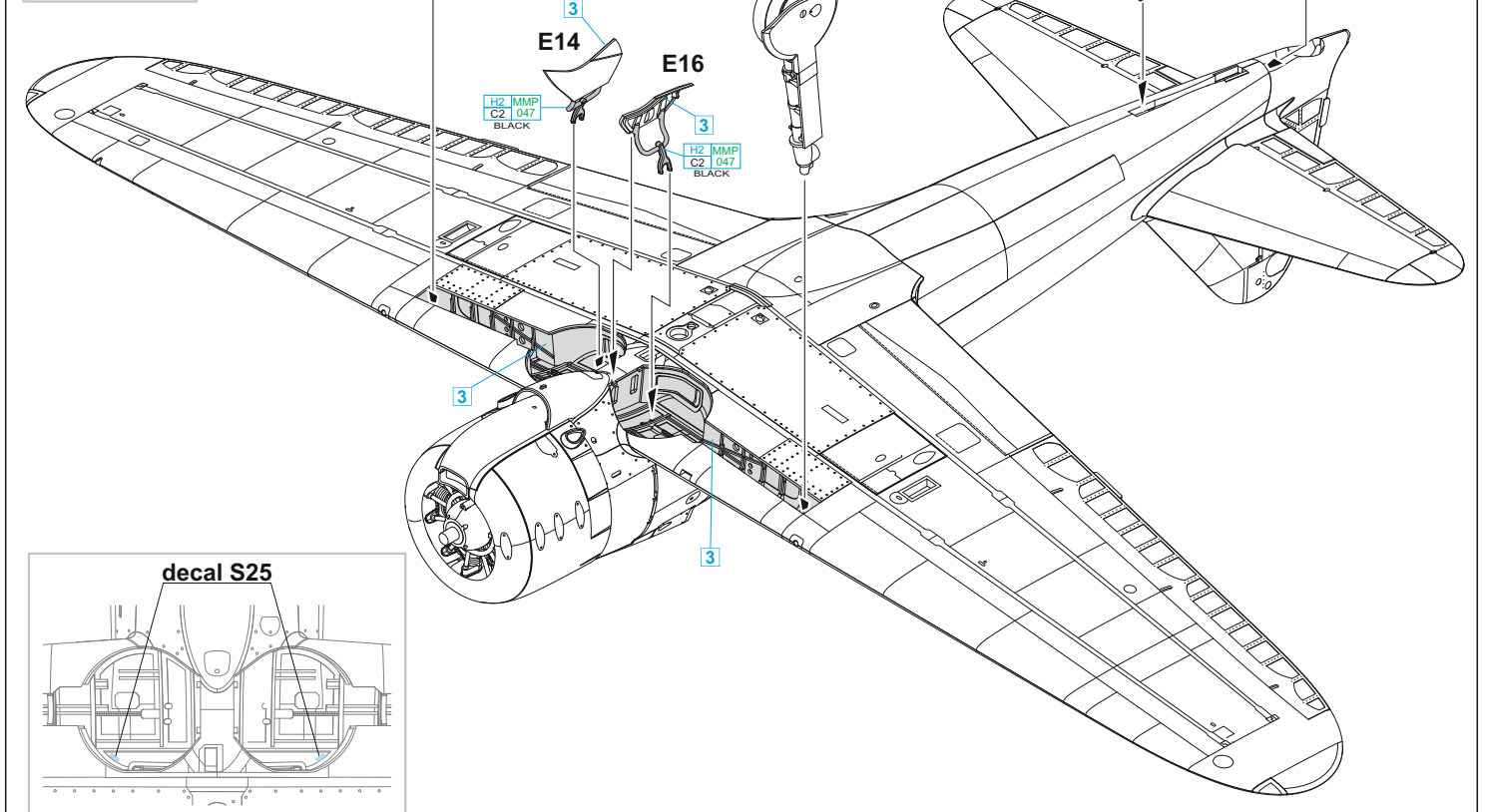
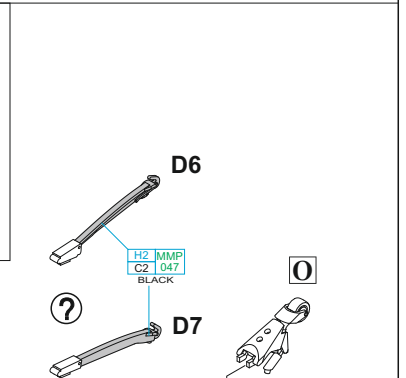
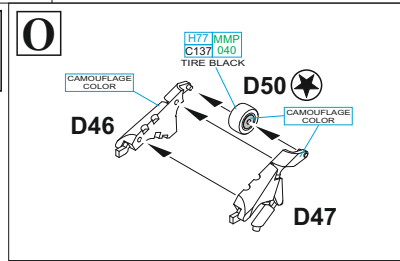
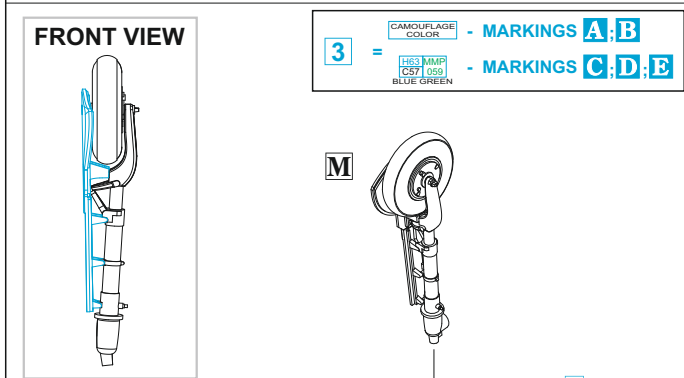
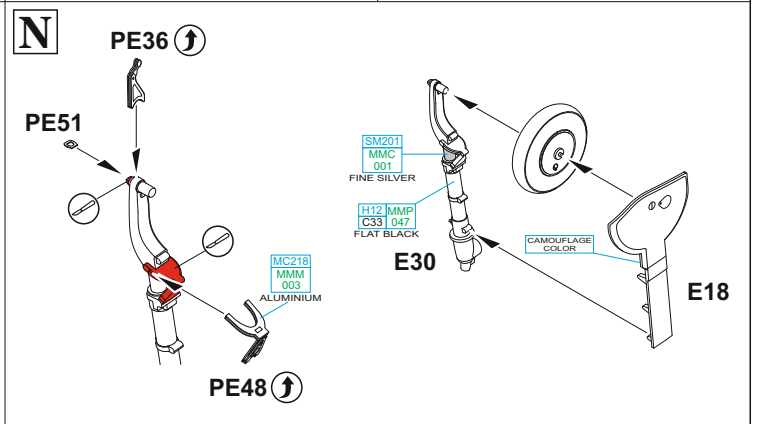
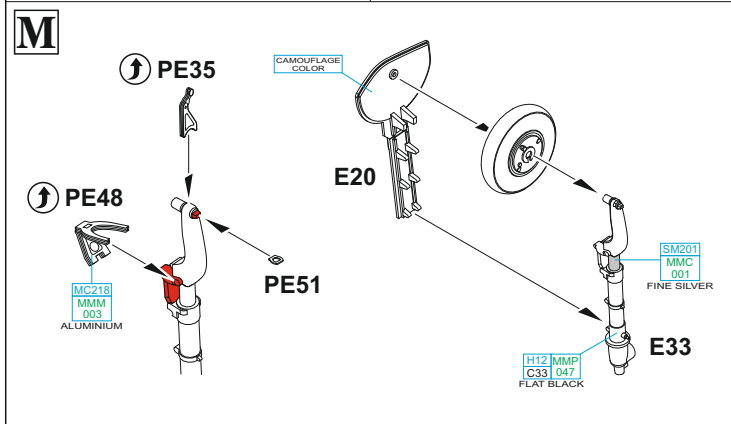
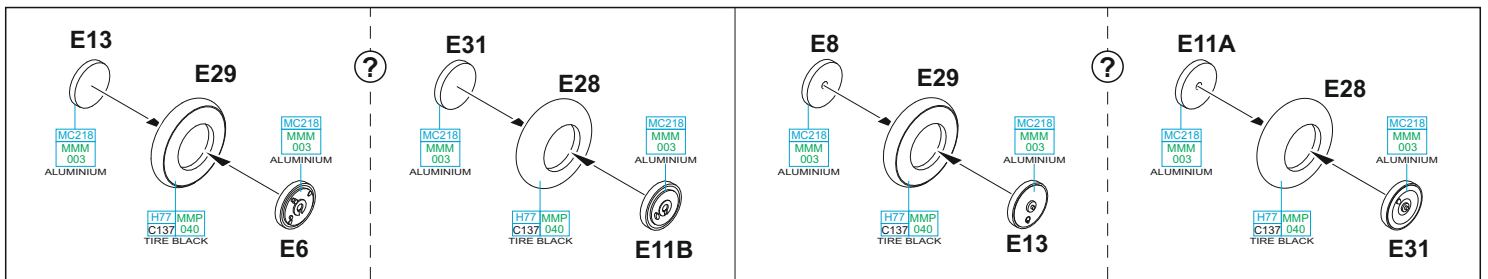

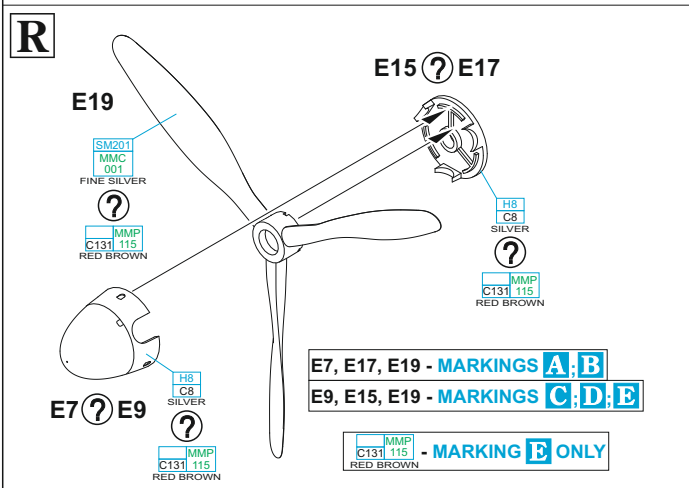
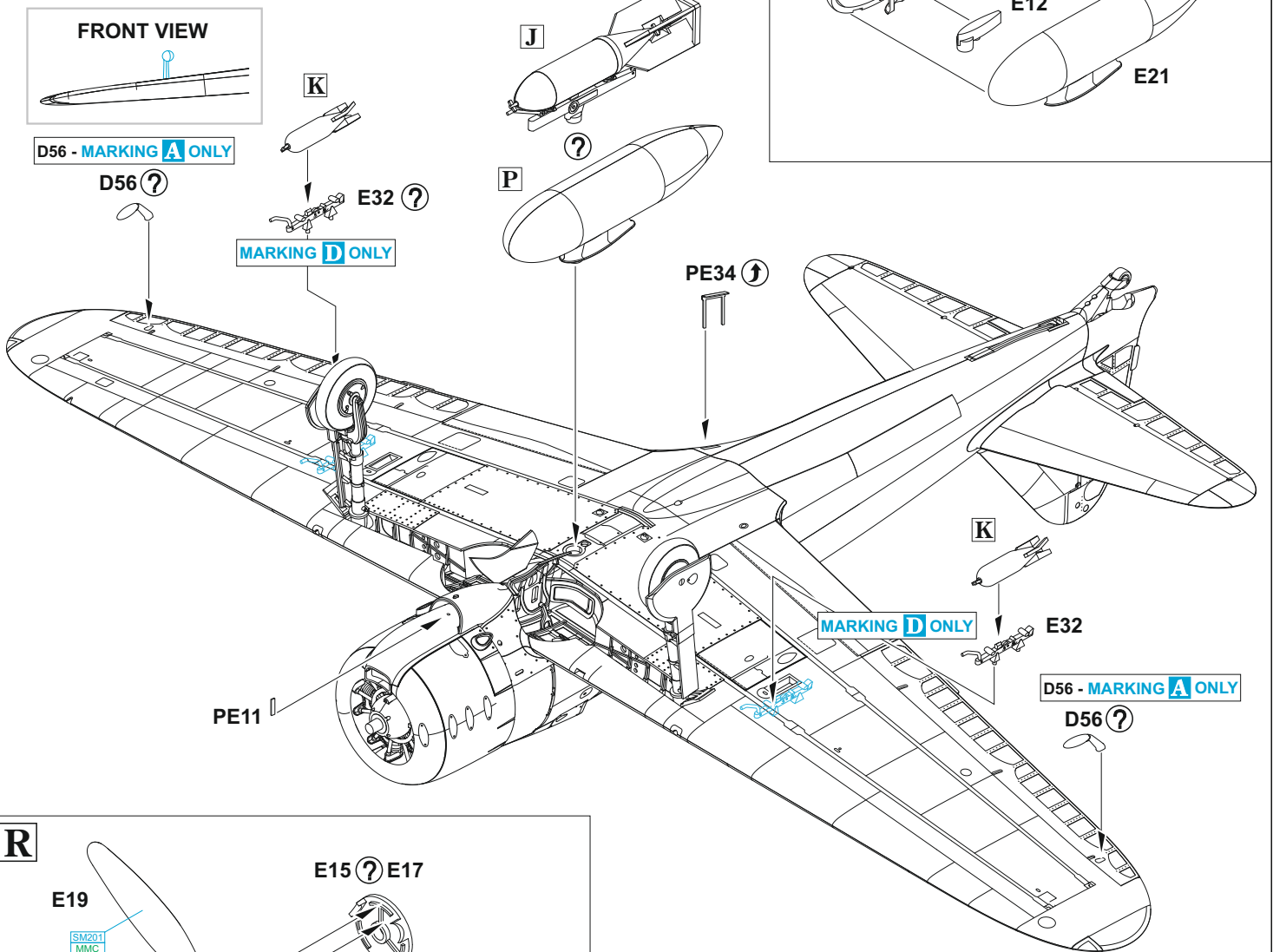
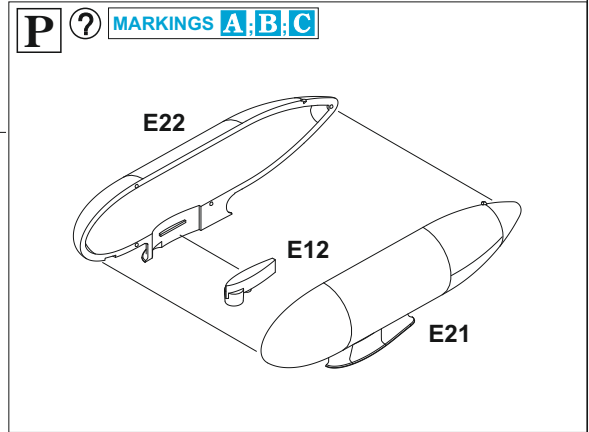
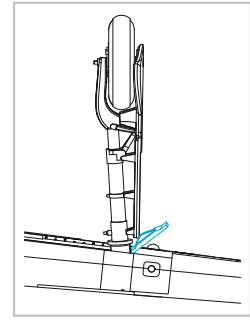
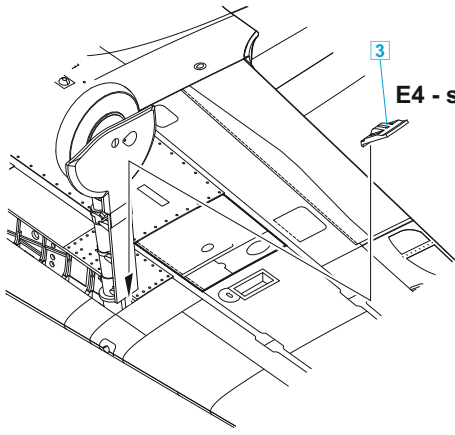

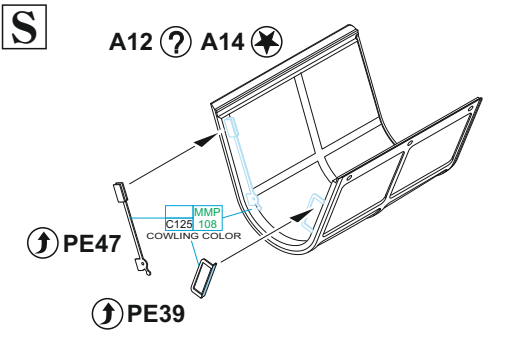
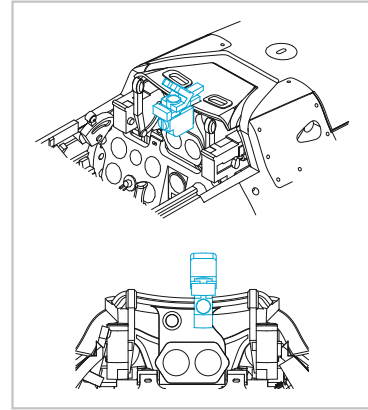
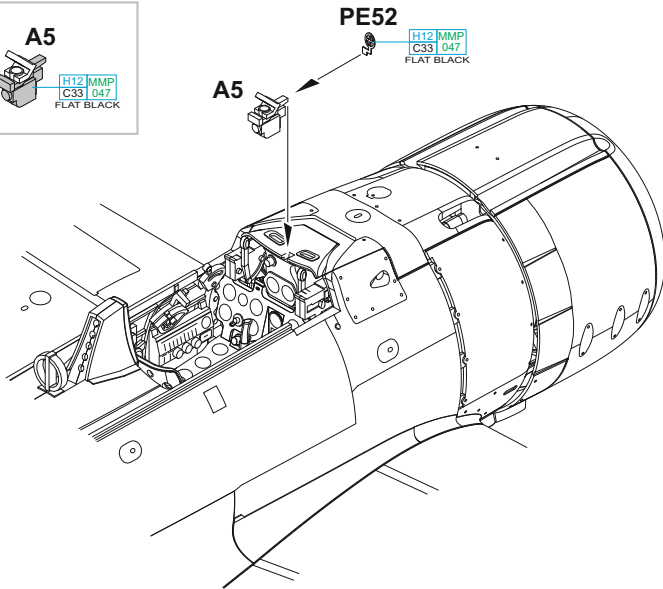
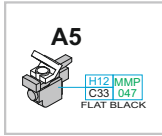

CLOSED CANOPY

A14 **S**

D53 **?** D54 **D54 - MARKINGS D, E ONLY**

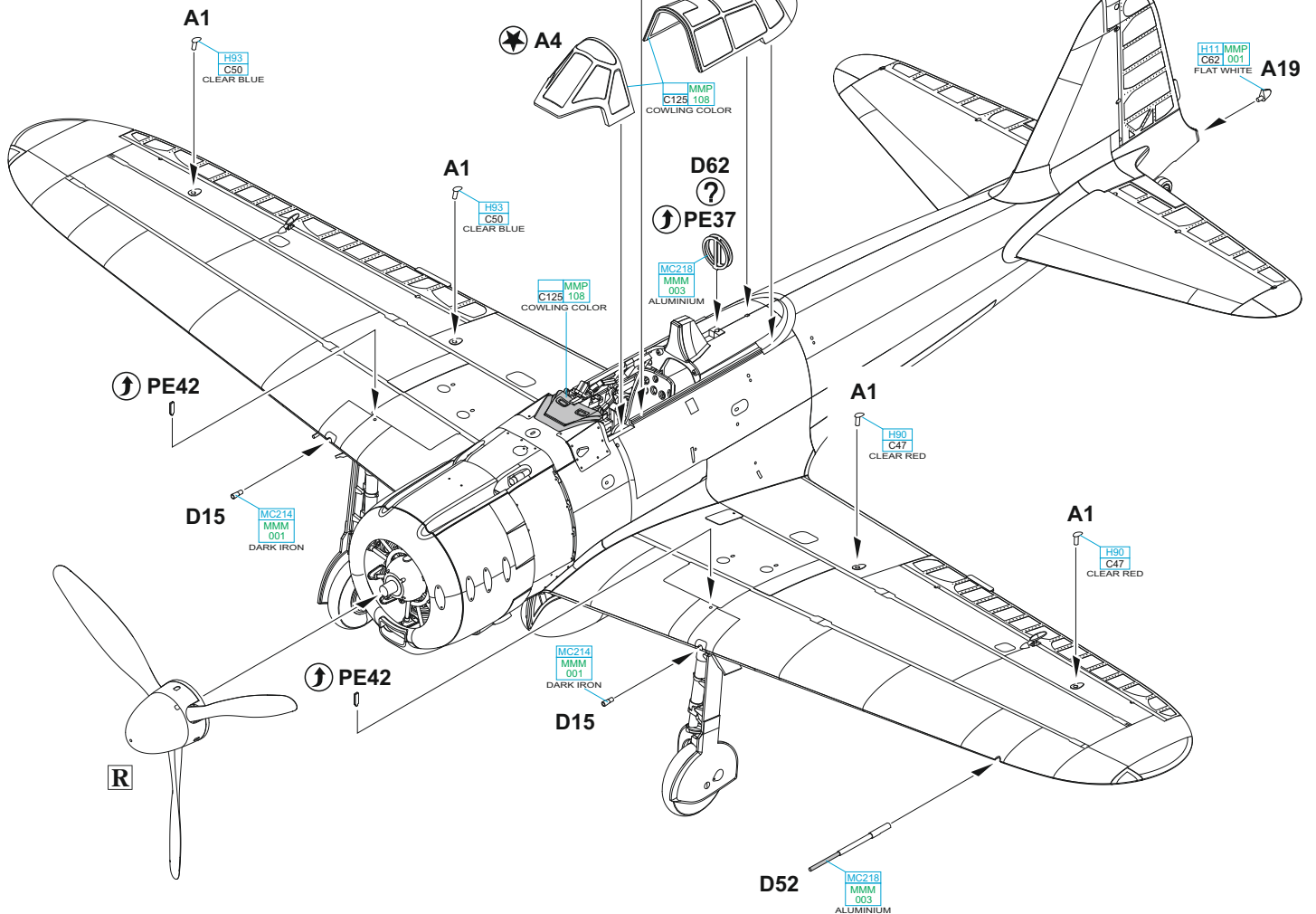

OPEN
CANOPY A12 S

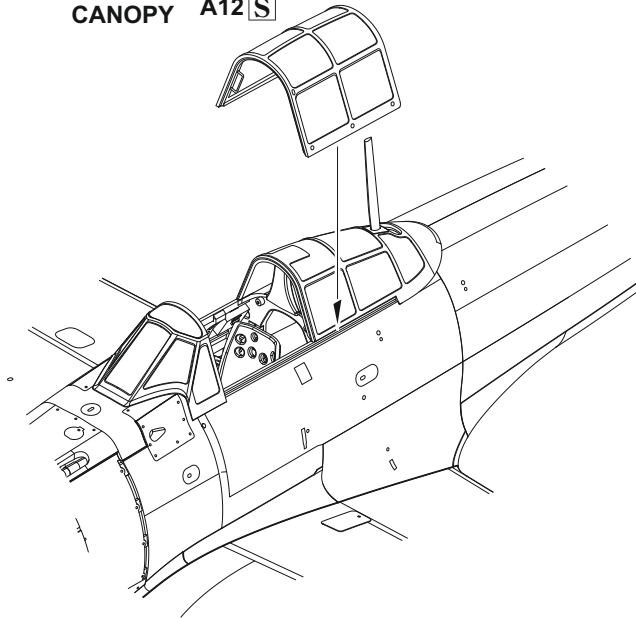

eduard
MASK
82212

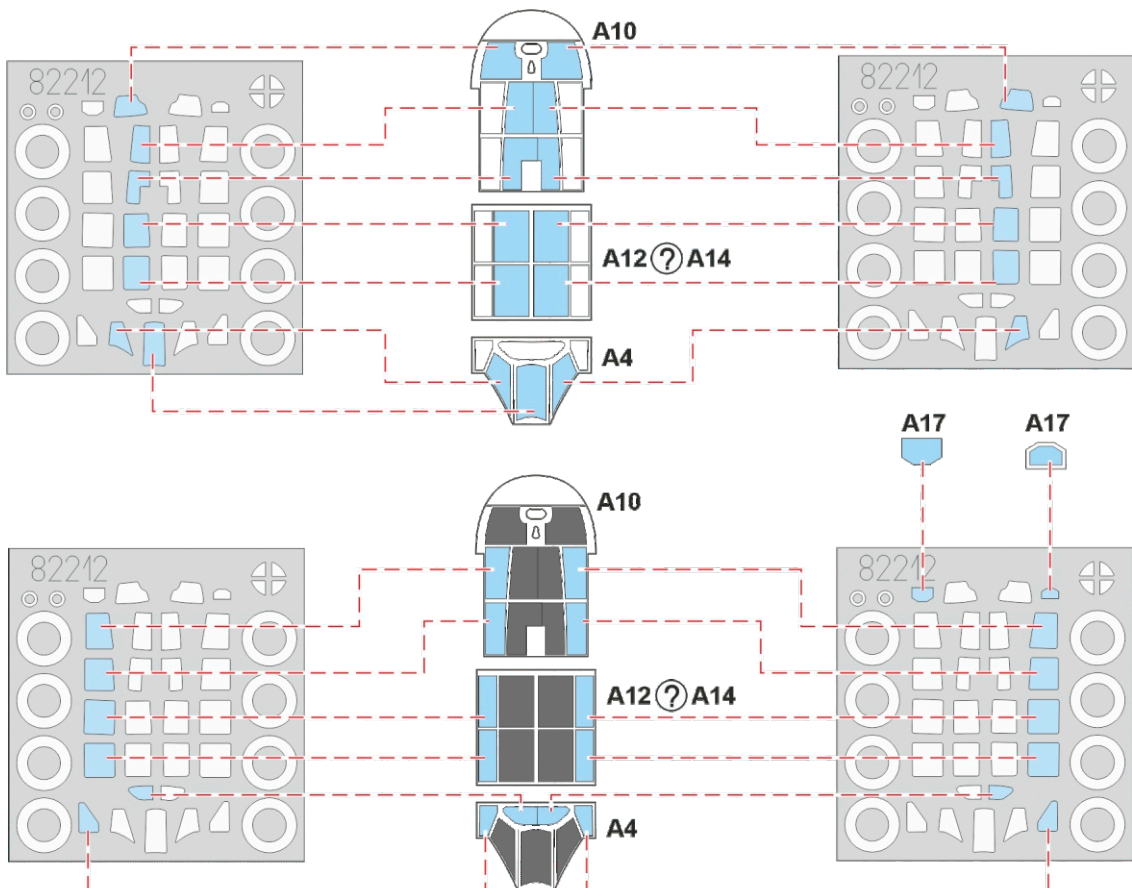
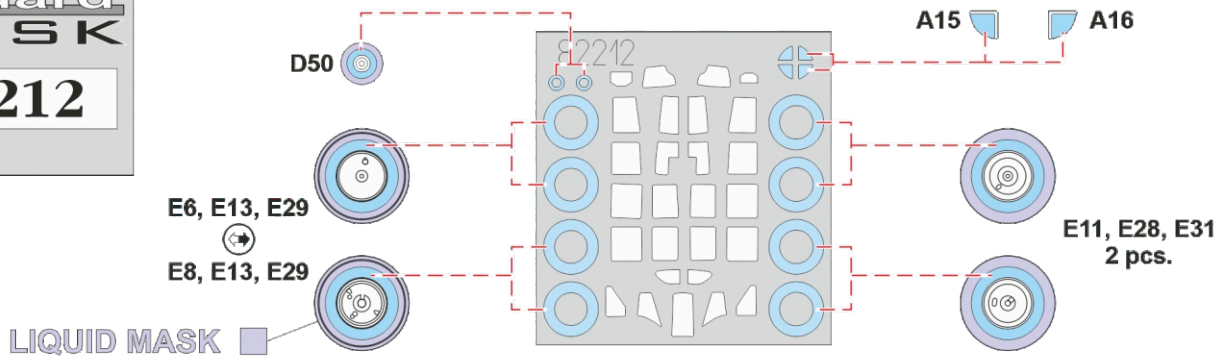

A c/n 5379, P01c Tsuguo Matsuyama, Hiryū Fighter Squadron, aircraft carrier Hiryū, December 7, 1941

During second attack against Hawaii the Hiryū aircraft carrier sent nine Zeros under the command of Lt. Sumio Nōno. His pilots attacked Kaneohe and Bellows bases, claiming two destroyed aircraft and one car. Third Shōtai was led by P01c Matsuyama, who shot down in cooperation with his wingman P-40s piloted by 2nd Lieutenants George Whiteman and Samuel Bishop of the 44th Pursuit Squadron. Matsuyama had combat missions with the 13th Kōkūtai in China on his account already. On February 25, 1938, as wingman of the legendary Sadaaki Akamatsu, he participated in shooting down four aircraft. During the raids on Ceylon on April 9, 1942, Matsuyama's shōtai shot down a Blenheim Mk.IV, probably of S/Ldr Kenneth Ault's crew, who was leading formation of No. 11 Squadron RAF in an attack on Japanese ships. Matsuyama later served on the aircraft carrier Hiyō and was killed on April 7, 1943 in combat with the Wildcats off Guadalcanal. The airplane BII-124 was shot down on February 19, 1942 during the raid on Darwin. After being hit by anti-aircraft fire, Seaman 1st class Hajime Toyoshima landed on Melville Island and was captured by Aboriginal Matthias Ulungura. Toyoshima was the first captured Zero pilot and used alias "Tadao Minami". He became one of the organizers of the largest prisoner escape in World War II. On August 5, 1944 at Cowra POW Camp he gave signal to escape. Total of 1,104 POWs attempted to escape, 231 were killed and four Australians lost their lives as well. Toyoshima was mortally wounded, so he lighted a cigarette and committed suicide.

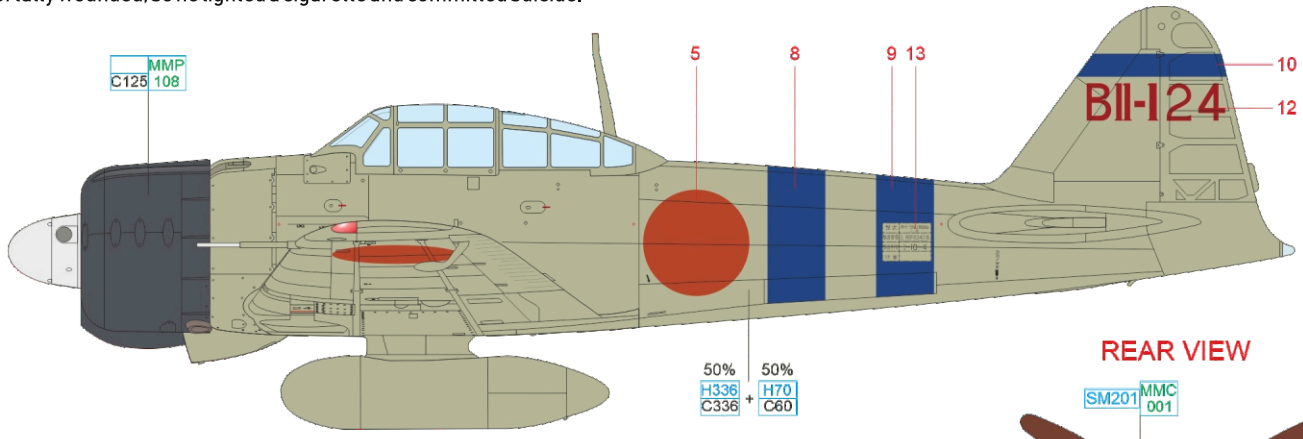

ČESKOU VERZI TEXTU NALEZNETE NA
www.eduard.com
 POD KATALOGOVÝM ČÍSLEM 82212

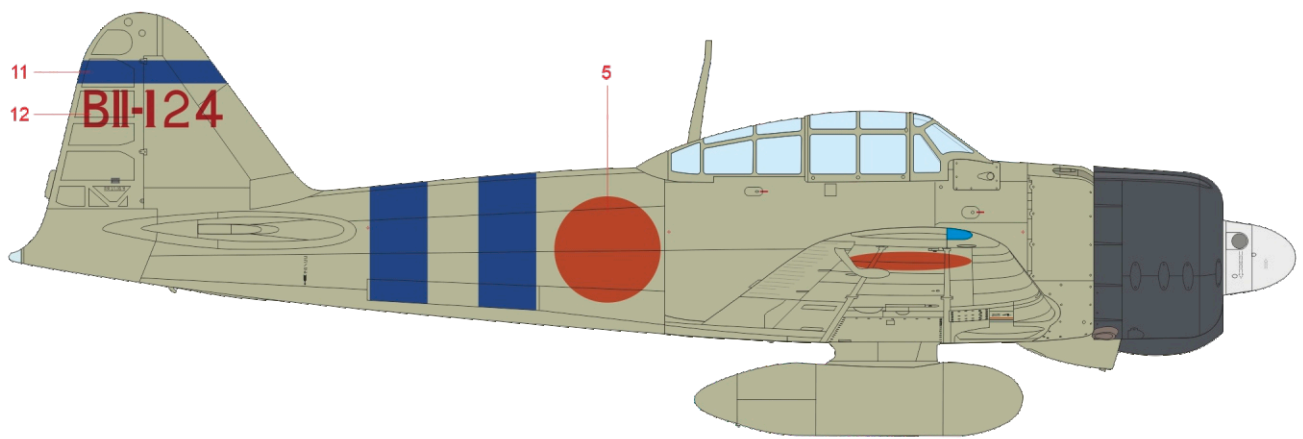
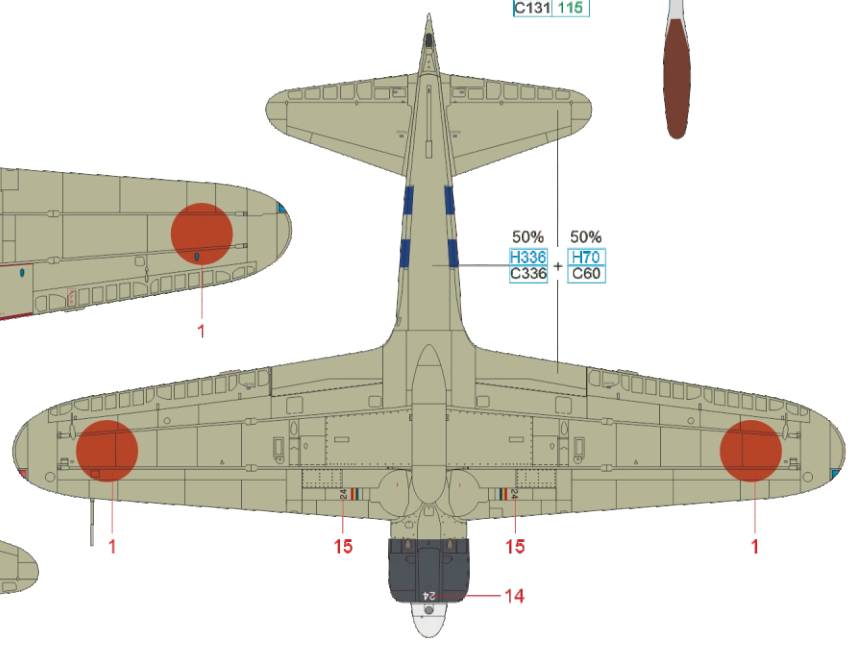
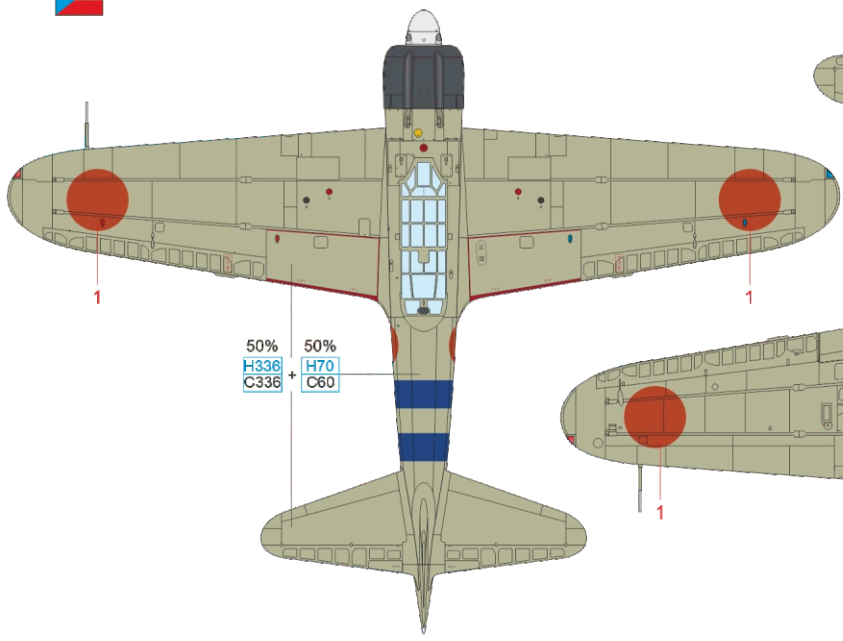

- HEMP H336 C336
- GRAY H70 C60
- COWLING COLOR MMP C125 108
- RED BROWN MMP C131 115
- SUPER FINE SILVER SM201 MMC 001

B P01c Saburō Sakai, Tainan Kōkūtai, Lakunai airfield, Rabaul, New Britain island, August 1942

Saburō Sakai is best known Japanese fighter pilot, thanks to his memoirs and meetings with Allied airmen after World War II. He was born in 1916 and served from September 1938 with the 12th Kōkūtai in China. In October 1941, he was assigned to the newly organized Tainan Kōkūtai in Taiwan and took part in campaign heading South until he was wounded on August 7, 1942 off Guadalcanal. After recovering, he served as an instructor with Ōmura Kōkūtai, and later, despite bad eyesight, was combat deployed with Yokosuka Kōkūtai on Iwo Jima. At the end of war he served with Kōkūtai 343 (II) and Yokosuka Kōkūtai. He is listed as an ace with 64 victories, but Sakai himself claimed the number of his victories was lower. With the first two units he actually achieved 12 individual victories, 8 shared and 4 probables. The V-128 was also flown by P02c Arita and P01c Hiroyoshi Nishizawa, who is credited with 87 victories. The color of the stripes is chosen from Sakai's recollection, but there are other interpretations, such as a black or yellow stripe on the fuselage. During a fighter escort to Guadalcanal on August 7, Sakai shot down Wildcat "F12" from VF-5 piloted by "Pug" Southerland in an epic dogfight. Sakai was later severely wounded in the face by fire from VB-6 Dauntless near Tulagi Island. After nearly five hours and more than 1,000 km, he managed to land back at Rabaul. Sakai died in 2000 after formal dinner with members of the US Navy.

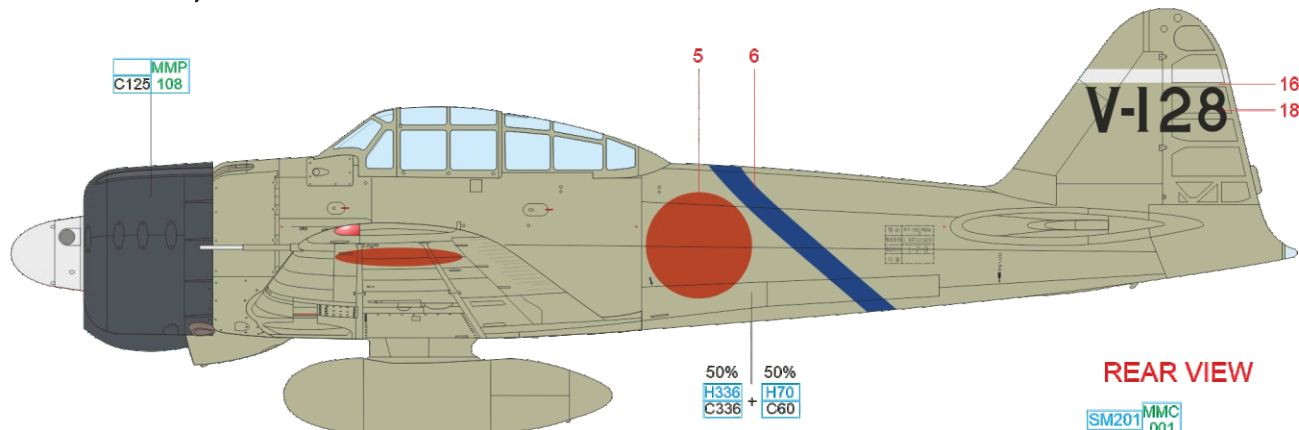

REAR VIEW

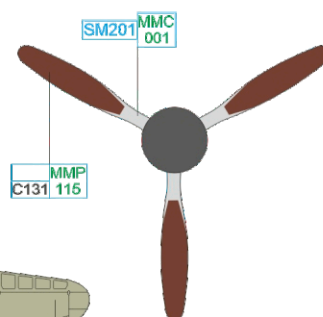

ČESKOU VERZI TEXTU NALEZNETE NA
www.eduard.com
POD KATALOGOVÝM ČÍSLEM 82212

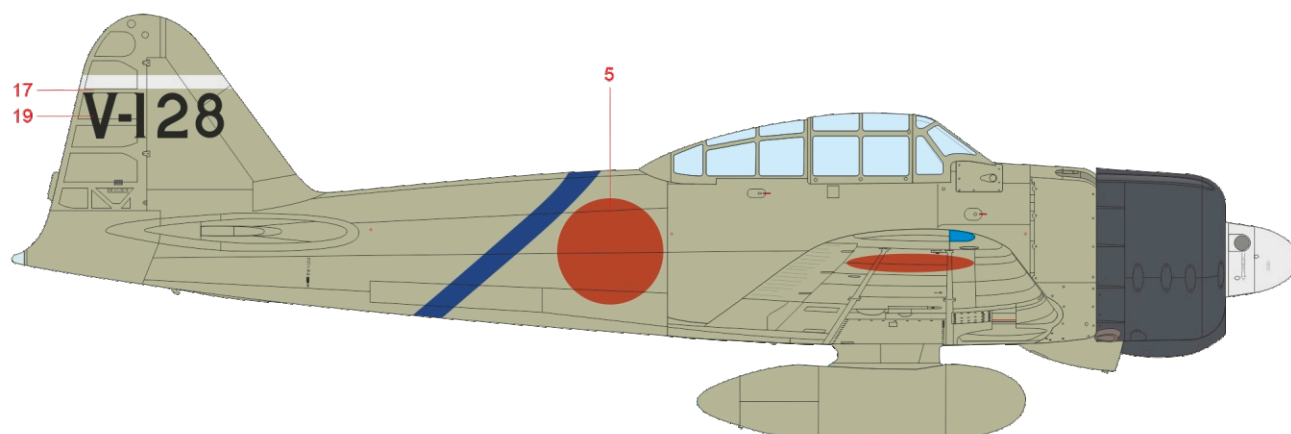
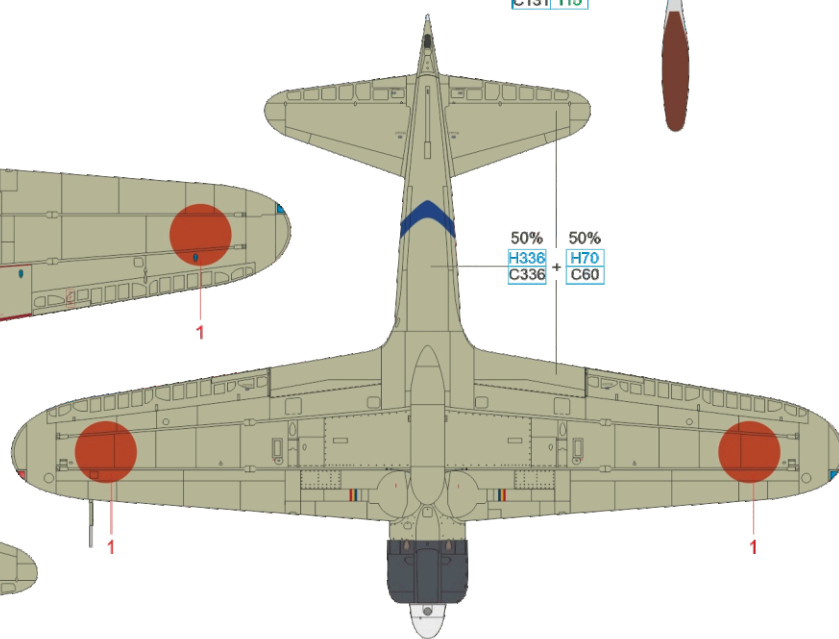
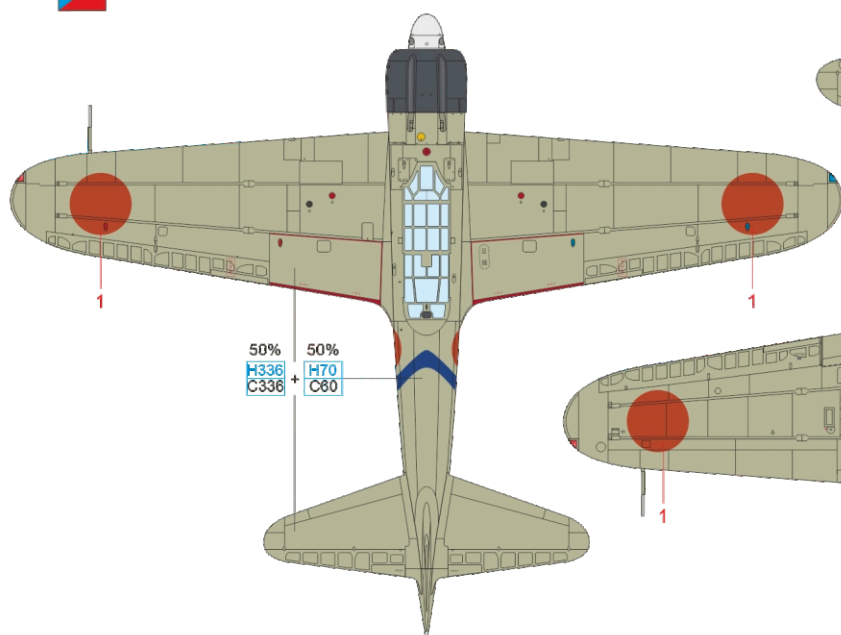

HEMP H336 C336 GRAY H70 C60 COWLING COLOR MMP C125 108 RED BROWN C131 115 SUPER FINE SILVER SM201 MMC 001

eduard

Petty Officer 2nd Class Koyae was born in 1923 in Miyazaki Prefecture and completed his flight training in November 1942. He was then assigned to the fighter unit of the aircraft carrier Zuihō in March 1943. In April, the unit moved to Rabaul and Koyae flew the aircraft during Operation I-gō. In this period, green paint was applied to Zeros in field conditions. It was usually painted by hand, the edges of the green fields being softened with thinner sometimes. However, according to the unit log, Koyae did not fly combat sorties in April 1943. In fact he did not encounter the enemy until November 1943 over Rabaul. During the same month he was transferred to Kōkūtai 253 at Rabaul and by early 1944 he was undergoing intense fighting. Upon his return to Japan, he was assigned to the Ōmura Kōkūtai. While on leave, on February 17, 1944, he spotted a Japanese bomber circling in the rain at night over the village of Goda, Miyazaki Prefecture. Koyae, with the help of the villagers, established a navigation signal and after some time he managed to guide the crew to right heading. For this achievement he received a written commendation from commander of Ōmura Kōkūtai. In July 1944, Koyae was assigned to Hikōtai 701 and fought in the defense of the Philippines. After returning to Japan, he was assigned to Hikōtai 701 (II) and served with Ōmura Kōkūtai at the end of the war. After the war he worked as a fireman and published his memories. According to the local press, he achieved 20 victories, but these may be victories achieved by fighter formations in which he took part.

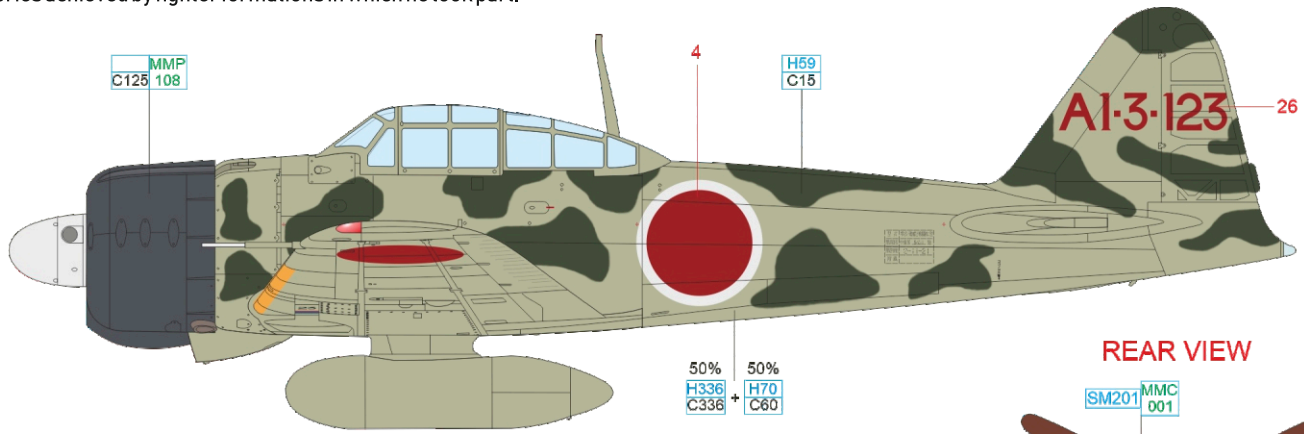

REAR VIEW

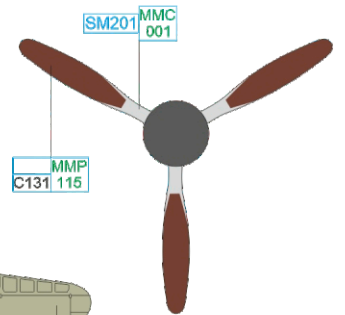

ČESKOU VERZI TEXTU NALEZNETE NA
www.eduard.com
POD KATALOGOVÝM ČÍSLEM 82212

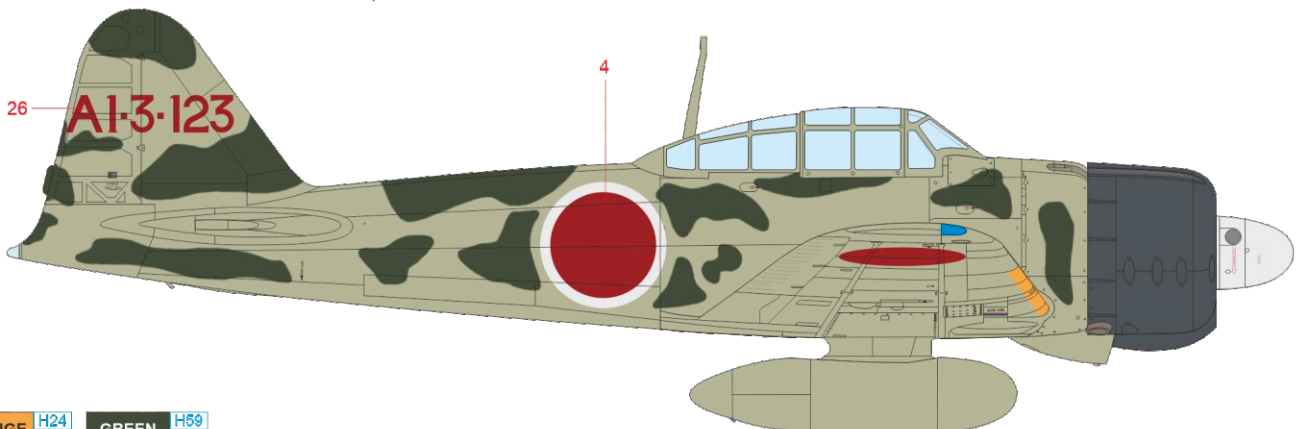
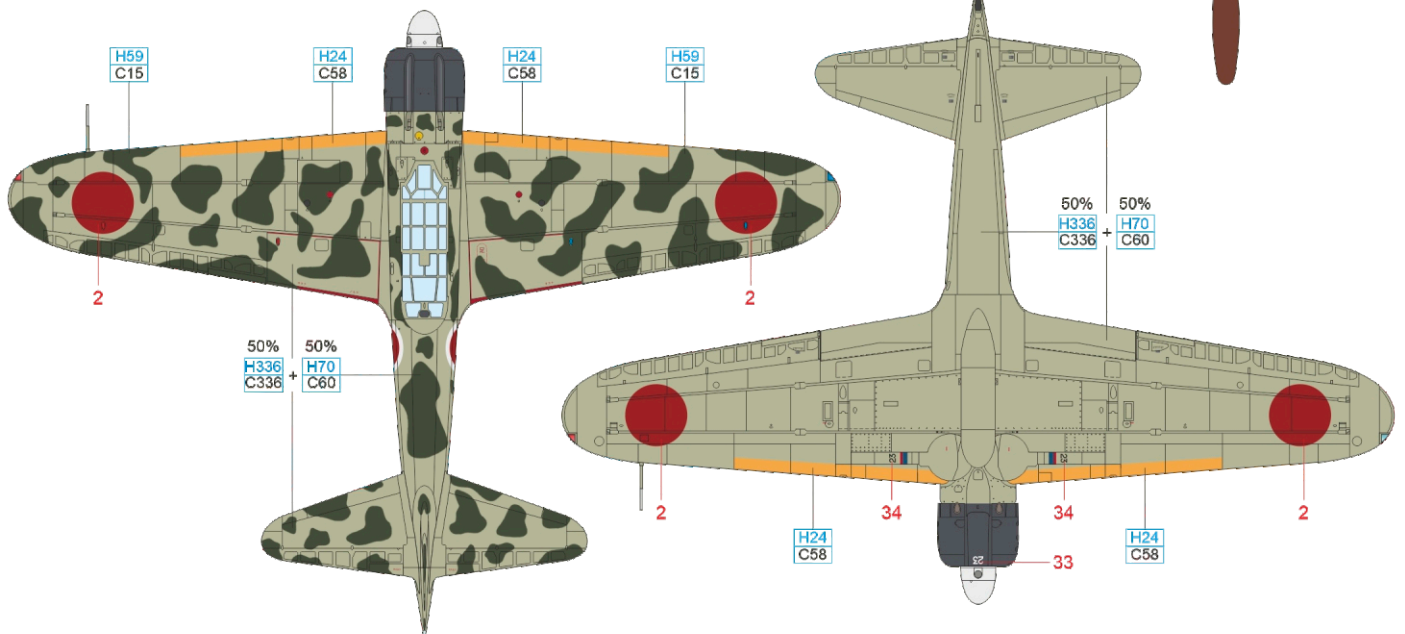

ORANGE	H24 C58	GREEN	H59 C15
HEMP	H336 C336	GRAY	H70 C60
COWLING COLOR	MMP C125 108	RED BROWN	MMP C131 115
SUPER FINE SILVER	SM201 MMC 001		

D Lt. Kunio Kanzaki, CO of Hikōtai 311 of Kōkūtai 381, Kendari airfield, Celebes island, May 1944

Kōkūtai 381 was established in October 1943 at Kendari Base on the island of Celebes. It was a mixed Kōkūtai with 48 fighter-bombers (Hikōtai 602), 24 night fighters (Hikōtai 902) and 48 fighter aircraft in Hikōtai 311, the latter commanded by Lt. Kanzaki. During the 1944 he operated from bases on islands in Indonesia and the Philippines. Their most frequent opponents were U.S. Army aircraft. Kanzaki's unit used special phosphorus anti-aircraft bombs to attack enemy bombers. Kanzaki's aircraft, manufactured by the Nakajima company, has been reconstructed in the past with various color markings. It is assumed that the vertical tail surfaces and part of the upper wing surfaces were painted the same color like lower surfaces. The front part of the engine may also have been painted grey or yellow. It is not entirely clear from the photograph of the aircraft whether the white stripes on the lower fuselage are joined. It may have been designed to improve the mutual identification of Army and Navy aircraft when fighting Allied fighters. Another reason for this camouflage may have been for easier identification during night fighter flights. For example, Lt. Kanzaki and his wingman shot down a B-24 of the 380th BG over Balikpapan on the night of January 12-13, 1944. Some aircraft of Kōkūtai 331 were also painted in the same upper and tailplane camouflage. Both units operated in one tactical group during part of 1944.

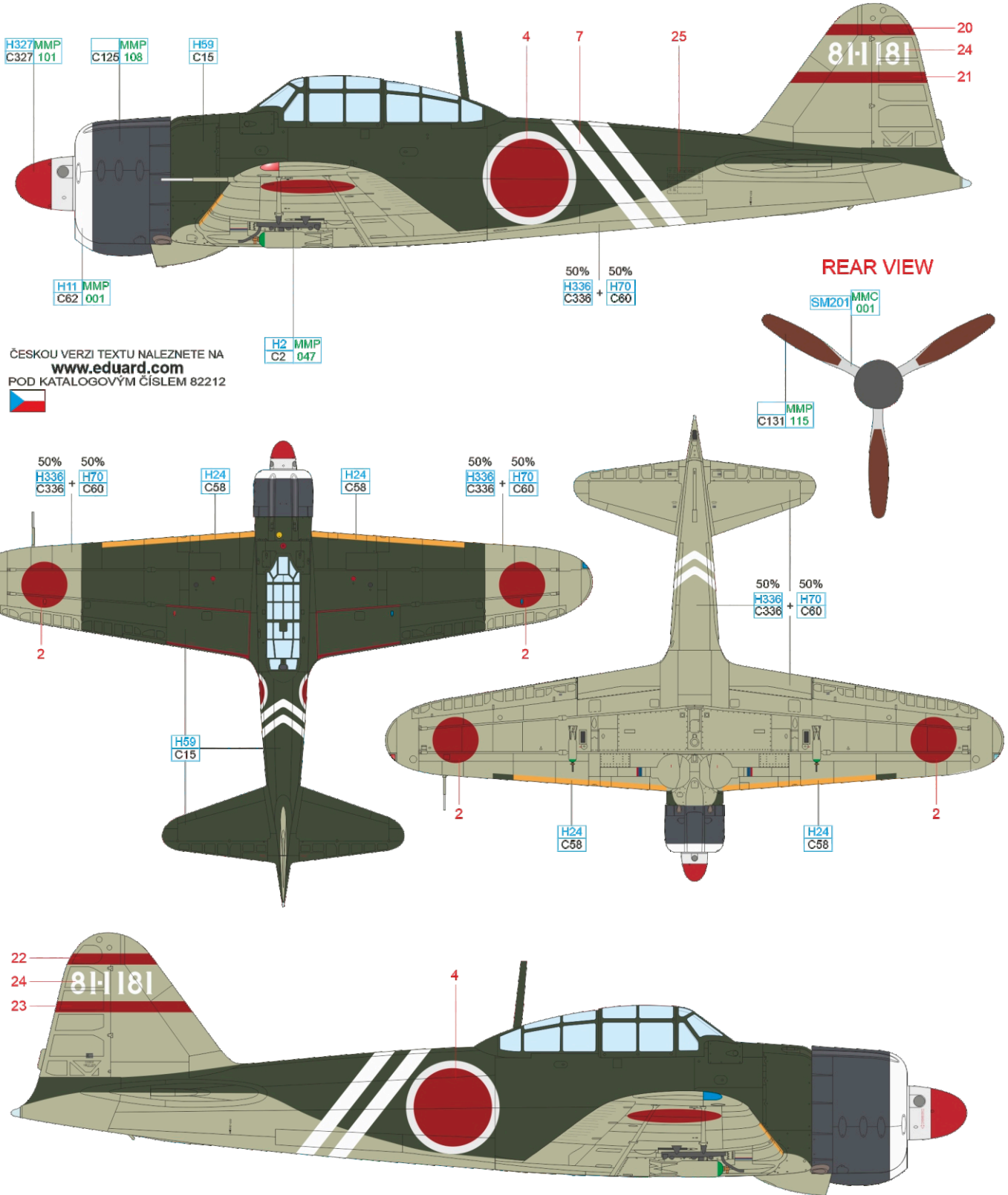

ČESKOU VERZI TEXTU NALEZNETE NA
www.eduard.com
 POD KATALOGOVÝM ČÍSLEM 82212

ORANGE	H24 C58	GREEN	H59 C15	WHITE	H11 MMP C62 001	RED	H327 MMP C327 101	BLACK	H2 MMP C2 047
HEMP	H336 C336	GRAY	H70 C60	COWLING COLOR	MMP C125 108	RED BROWN	MMP C131 115	SUPER FINE SILVER	SM201 MMC 001

E Lt. Nobuo Miyatake, Kamikaze Tokubetsu Kōgekitai, 1. Shichisei-tai, Kanoya airbase, Japan, April 1944

From the April 3, 1945 a total of eight special attack units with the battle name "Shichisei" were organized from the airmen serving in Genzan Kōkūtai (II) and Hikōtai 306 (part of Kōkūtai 721). Lt. Miyatake, who was 24 years old at the time, led the 1st Shichisei-tai in an attack on a convoy off Okinawa on April 6, 1945. During that day, eleven other airmen from Genzan Kōkūtai (II) sacrificed their lives along with him. They took off successively in four formations. Their formation was part of the 524 aircraft of special attack units and escort fighters from IJN and IJA sent against Allied vessels off Okinawa as part of Operation Kikusui 1. The U.S. Navy lost destroyers USS Bush and Colhoun and other ships were severely damaged. "Shichisei" units were sent against ships off Okinawa, Yoronjima, Kikaijima, and Tanegashima islands in several missions till May 14. Only one of them returned to base due to bad weather. Lt. Miyatake was born in Kagawa Prefecture and graduated from the Etajima Naval Academy in 1942. Before the mission, he wrote farewell letters to his mother and three sisters. His father was interned in Siberia at the time. Nobuo Miyatake was posthumously promoted to the rank of Commander. His aircraft from Nakajima production is designated "Ke-113".

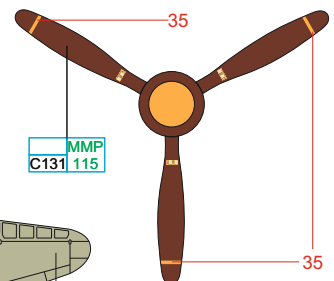
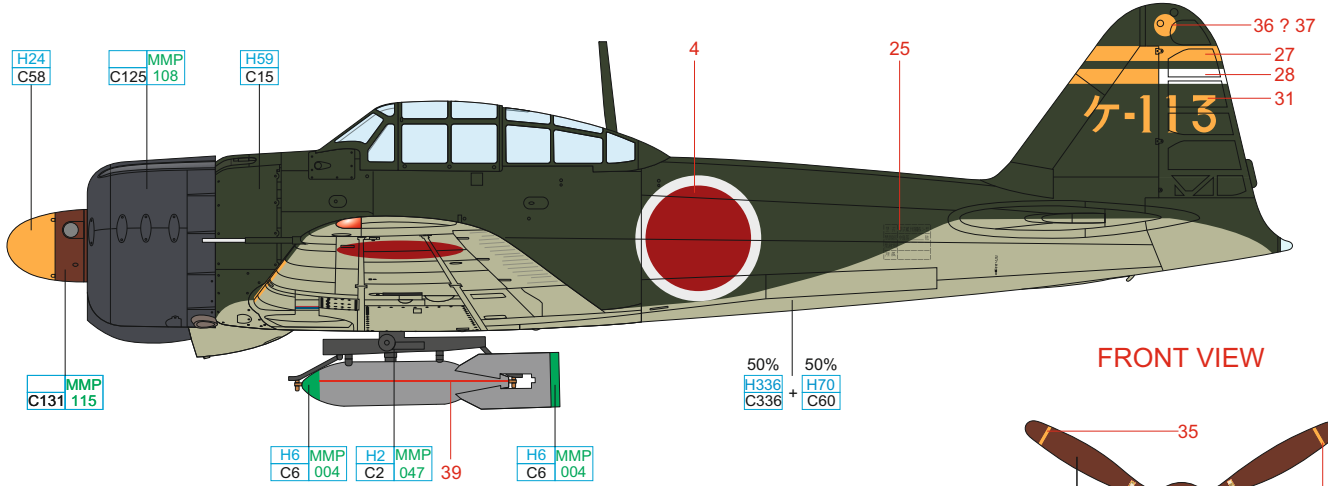

ČESKOU VERZI TEXTU NALEZNETE NA
www.eduard.com
 POD KATALOGOVÝM ČÍSLEM 82212

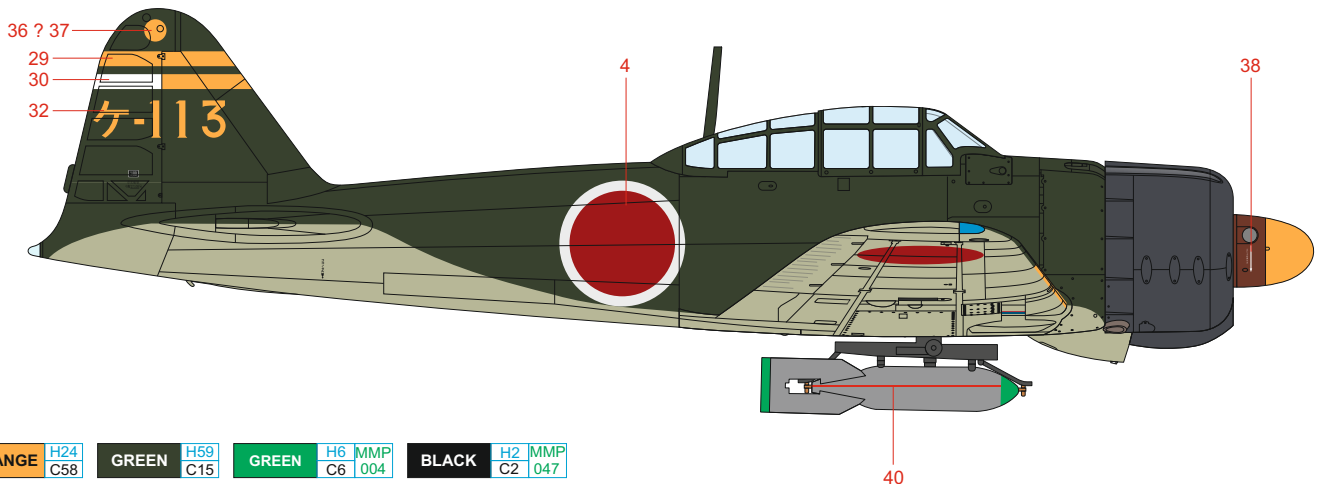
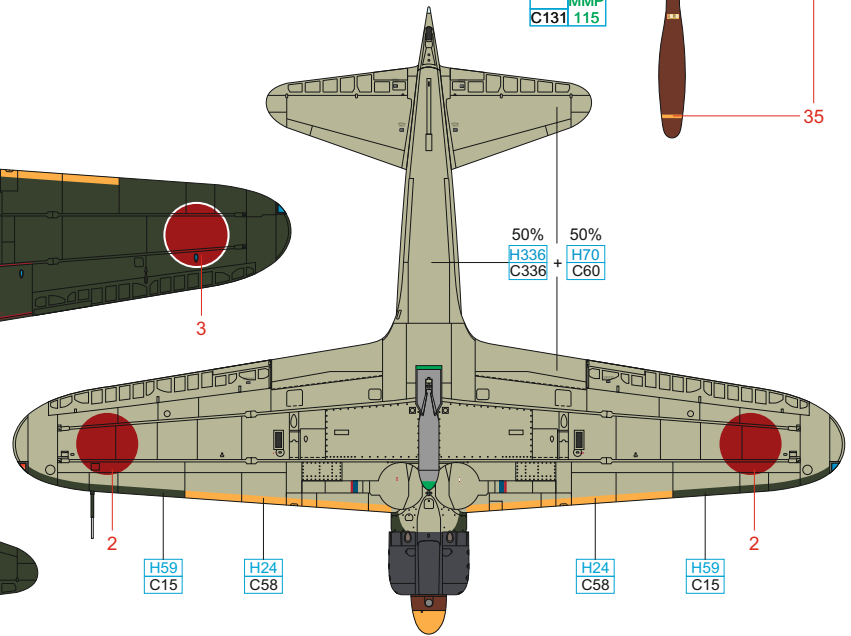
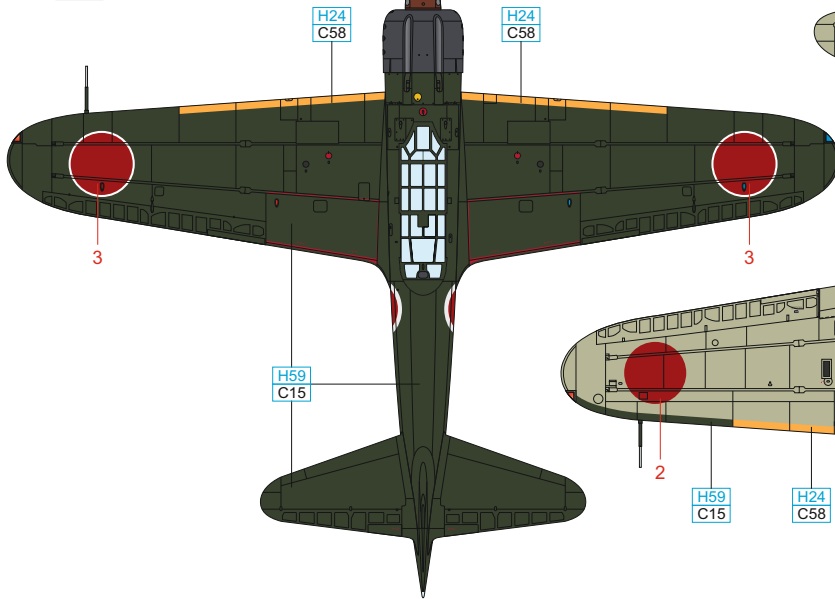

ORANGE	H24 C58	GREEN	H59 C15	GREEN	H6 MMP C6 004	BLACK	H2 MMP C2 047
HEMP	H336 C336	GRAY	H70 C60	COWLING COLOR	MMP C125 108	RED BROWN	MMP C131 115

A6M2 Zero Type 21

STENCILING POSITIONS

* - STENCILS SIGNED WITH * ARE FOR MARKINGS C D E (NAKAJIMA BUILT AIRCRAFT)

