

MiG-21MF

eduard

1/48 Scale Plastic Model Kit

ProfiPACK
edition



item No. 8231

The MiG-21 was the most-produced supersonic fighter in the world and served with more than fifty Air Forces over four continents. This tiny interceptor or fighter-bomber played remarkable role in many wars and local conflicts from sixties to eighties, allowing many pilots to achieve their ace combat status.

The MiG-21 was one of a long-list of Mikoyan-Gurevich designs integrated into the armed forces of the Soviet Union, the Warsaw Pact, and allied client states. Its predecessors included such notable types as the MiG-15, MiG-17, and the supersonic MiG-19.

The roots of MiG-21 project reach back to the first half of the fifties. In 1954, when the preliminary design study Ye-1 came to its end and was quickly replaced by the reworked Ye-2 prototype. Both had a swept wing. The first MiG design to feature the delta wing was the Ye-4 prototype, which took to the air for the first time on June 16, 1955. It was also demonstrated a year later at the Moscow airfield Tushino.

The new aircraft with the MiG-21 designation was the first successful design integrating fighter and interceptor characteristics. It was also quite light Mach 2 aircraft, although the long-lasting development was adding weight gradually. The design featured sleek fuselage with the front air intake and shock cone. This feature later limited future development due to the very small space available for the radar.

Cold War warrior

The first of the new line to enter production was the MiG-21F, which together with the MiG-21P and MiG-21F-13 represented the first generation of this line. These versions were in production through the end of the fifties and the beginning of the sixties. Subsequent versions included the PF, FL, PFM and R with production of these peaking at the end of the sixties. The production of third generation of the MiG-21 started in 1968 and included the most advanced versions of the type like the M, SM, MF, SMT or bis among others. Simultaneously, two-seat training versions were also produced designated MiG-21U, UM and US.

Production of the MiG-21 ended in 1985. The new aircraft came off Soviet production lines in Moscow, Gorky and Tbilisi, the MiG-21F-13 was also built under license in Czechoslovakia and the MiG-21FL, M and bis in India by Hindustan Aeronautics Ltd. The Soviet Union produced 10,645 examples of all versions, 194 were built in Czechoslovakia and 657 in India. That counts 11,496 aircraft produced.

Over the course of the Cold War, the opponents of the MiG-21 included the likes of the Northrop F-5 Freedom Fighter or the Dassault Mirage III. NATO assigned MiG-21 code reporting name "Fishbed", while the Soviet pilots called it "Balalaika" due to the shape resembling it with the Russian musical instrument.

Aces from Asia, Middle East or Africa

Outside of the Soviet Union, the type flew with a long list of nations on four continents (Europe, Asia, Africa and South America)

and participated in many conflicts and wars. The most remarkable combat use includes the Vietnam war, the Indo-Pakistan wars, the Cuban participation in Angola and in the Arab world's attempts to eliminate Israel. It is no wonder there were many pilots achieving their ace status flying one or more variants of MiG-21.

Thanks to the high volume of use and intensive combat actions, the Vietnamese pilots are topping the list of aces of MiG-21. The top of the ladder is occupied by Nguyen Ven Coc with nine kills with three eight-victory aces following: Mai Van Cuong, Nguyen Hong Nhi and Pham Thanh Ngan. Of the other nations the Syrian pilots Bassam Hamshun and Majid Zugbi both achieved seven kills flying MiG-21MF, while Adeeab Al-Jarf had the same score with MiG-21FL and Egyptian pilots Ali Vajai, Sami Marei and Sami Marei scored five times.

In the interceptor role the MiG-21 served with the Soviet Union and other nations of the Warsaw Pact into the eighties when it began to be replaced by the MiG-23 in seventies and MiG-29 Fulcrum in eighties.

This kit: MiG-21MF

This plastic model kit represents the MiG-21MF, an export version of the MiG-21SM where the "M" signifies "modernizovaniy" (modernized) and the "F" "forsirovanniy" (with afterburner). The MiG-21MF lacked some of the "sensitive" avionics equipment of the SM version. On the other hand it also sported some improvements to its export predecessor, the MiG-21M, in several aspects. It was powered by more powerful Tumansky R-13-300 engine with afterburning and carried the Safir-21/RP-22 radar instead of less effective RP-21MA of MiG-21M. The MiG-21MF type was identified as Izdelye (series) 96F in factory documentation.

The production started in the Moscow factory No. 30, with first batch of 96 production aircraft in 1969 (it is believed these were shipped to Egypt). Starting from 1974 the production was shifted to the No. 21 factory in Gorky, where 231 aircraft were built before the production shifted to the MiG-21bis version in 1976.

Although the MiG-21MF was export version, several aircraft saw service with 234. GIAP (Guard Fighter Regiment) of VVS (Soviet Air Force) located at the Kubinka air base. The reason was quite simple - the unit was tasked with flight demonstrations for foreign clients and also with the official parade and display flights. The armament consisted of the GSh-23-2L 23mm cannon with 200 rounds. The underwing pylons could carry a combination of FAB bombs up to 500 kg caliber, UB-16-57 rocket pods, R-3S, Ch-66 or S-24 missiles, and R-60 air-to-air missile, including the R-60M. NATO assigned the MiG-21MF codename "Fishbed J".

ATTENTION



UPOZORNĚNÍ



ACHTUNG



ATTENTION



注意



Carefully read instruction sheet before assembling. When you use glue or paint, do not use near open flame and use in well ventilated room. Keep out of reach of small children. Children must not be allowed to suck any part, or pull vinyl bag over the head.



Před započítím stavby si pečlivě prostudujte stavební návod. Při používání barev a lepidel pracujte v dobře větrané místnosti. Lepidla ani barvy nepoužívejte v blízkosti otevřeného ohně. Model není určen malým dětem, mohlo by dojít k požití drobných dílů.

INSTRUCTION SIGNS * INSTR. SYMBOLS * INSTRUKTION SINNBILDEN * SYMBOLES * 記号の説明

OPTIONAL
VOLBABEND
OHNOUTSAND
BROUSITOPEN HOLE
VYVRTAT OTVORSYMETRICAL ASSEMBLY
SYMETRICKÁ MONTÁŽREMOVE
ODŘÍZNOUTREVERSE SIDE
OTOČITAPPLY EDUARD MASK
AND PAINT
POUŽIT EDUARD MASK
NABARVIT

PARTS



DÍLY



TEILE



PIÈCES



部品

PLASTIC PARTS

A>

8230 A

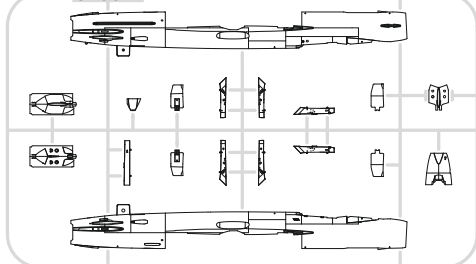

B>

8230 B

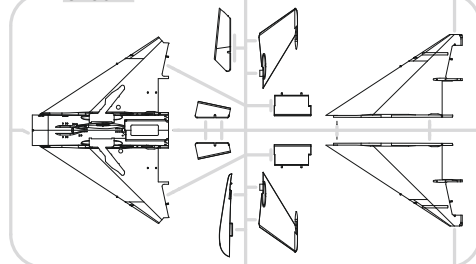

C>

8230 C

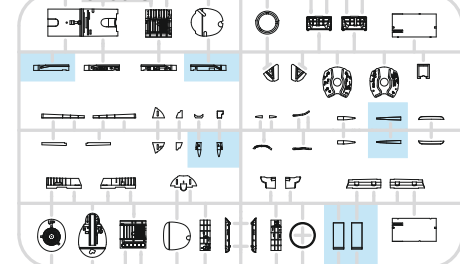

D>

8230 D

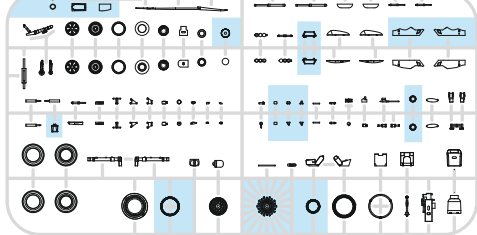

E> 2 pcs.

8230 E

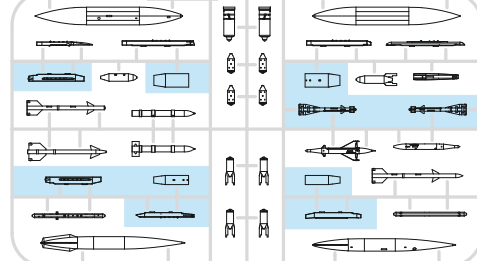

F>

8230 F

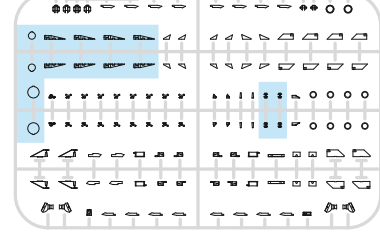

G>

8230 G

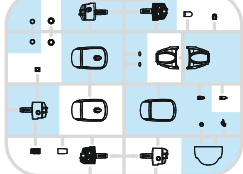

H>

8230 H

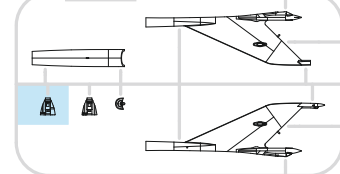
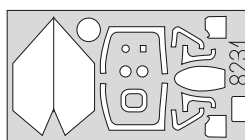
eduard
MASK

PE - PHOTO ETCHED DETAIL PARTS

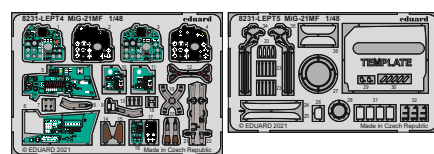

-Parts not for use. -Teile werden nicht verwendet. -Pièces à ne pas utiliser. -Tyto díly nepoužívejte při stavbě. - 使用しない部品

COLOURS



BARVY



FARBEN



PEINTURE



色

GSI Creos (GUNZE)		MISSION MODELS	
AQUEOUS	Mr.COLOR	PAINTS	
H1	C1	MMP-001	WHITE
H3	C3	MMP-003	RED
H4	C4	MMP-007	YELLOW
H5	C5	MMP-048	BLUE
H6	C6	MMP-004	GREEN
H11	C62	MMP-001	FLAT WHITE
H12	C33	MMP-047	FLAT BLACK
H14	C59	MMP-005	ORANGE
H21	C69		OFF WHITE
H26	C66		BRIGHT GREEN
H32	C40		FIELD GRAY
H37	C43		WOOD BROWN
H44	C51		FLESH
H47	C41	MMP-012	RED BROWN
H51	C11	MMP-063	LIGHT GULL GRAY
H52	C12	MMP-091	OLIVE DRAB
H53	C13		NEUTRAL GRAY
H58	C351	MMP-059	INTERIOR GREEN
H60	C16		GREEN
H67	C115	MMP-057	RLM65 LIGHT BLUE

GSI Creos (GUNZE)		MISSION MODELS	
AQUEOUS	Mr.COLOR	PAINTS	
H70	C60	MMP-056	RLM02 GRAY
H71	C21	MMP-076	MIDDLE STONE
H77	C137	MMP-040	TIRE BLACK
H78	C38		OLIVE GREEN
H81	C55	MMP-023	KHAKI
H84	C42		MAHOGANY
H90	C47		CLEAR RED
H94	C138		CLEAR GREEN
H302	C302		GREEN
H305	C305	MMP-084	GRAY
H306	C306	MMP-118	MEDIUM GRAY
H308	C308	MMP-073	GRAY
H332	C332		LIGHT AIRCRAFT GRAY
H417	C117	MMP-051	RLM76 LIGHT BLUE
	C391		INTERIOR GREEN
Mr.METAL COLOR		METALLICS	
MC213		MMM-006	STEEL
MC214		MMM-001	DARK IRON
MC218		MMM-003	ALUMINIUM
Mr.COLOR SUPER METALLIC		METALLICS	
SM201		MMC-001	SUPER FINE SILVER 2

OPTIONAL: decal 79, 82 ? 82, 83

PE1, PE2 ? PE3, PE4

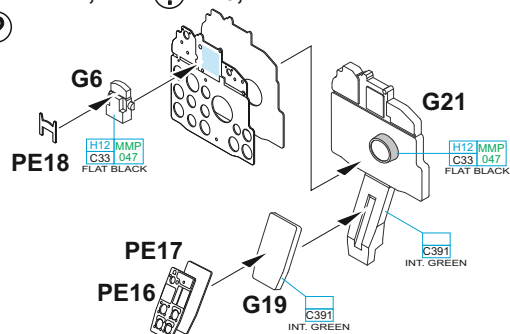
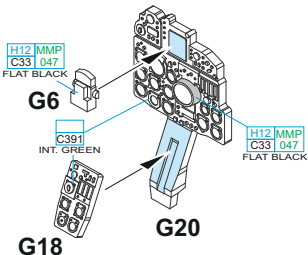
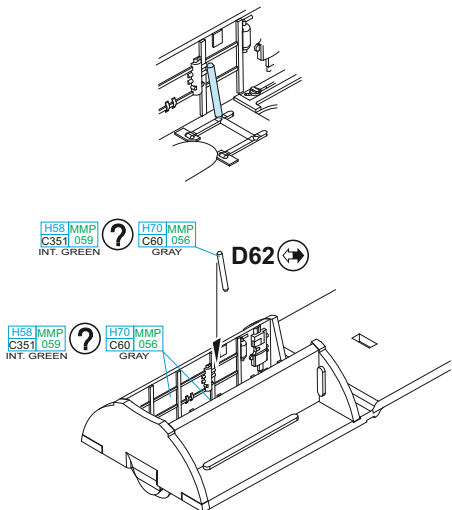

decal 79 - MARKINGS A, B, C, E, F
decal 83 - MARKING D

PE1, PE2 - MARKINGS A, B, C, E, F
PE3, PE4 - MARKING D

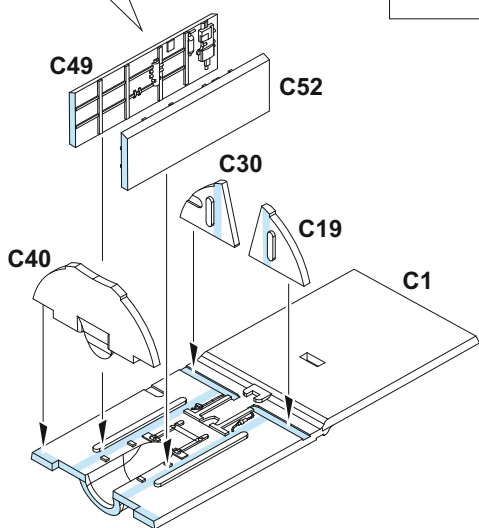
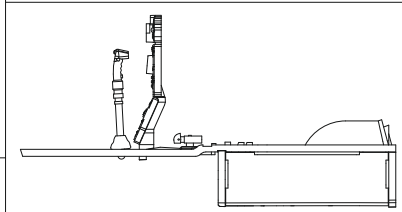

D20 - OPEN CANOPY ONLY

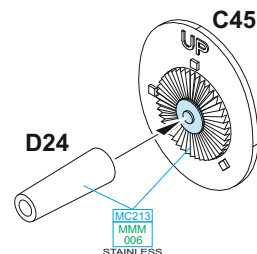
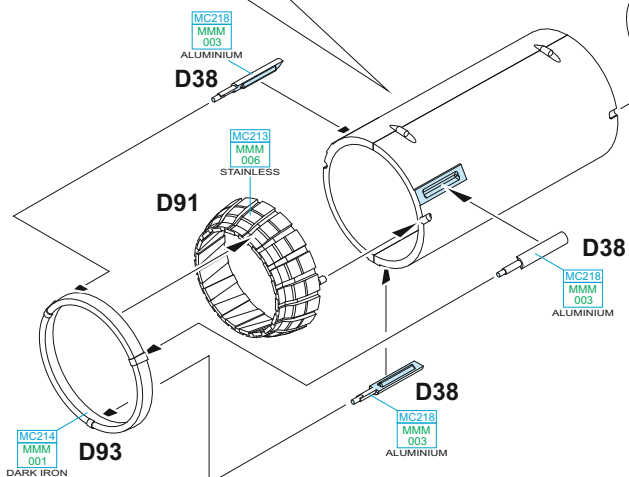
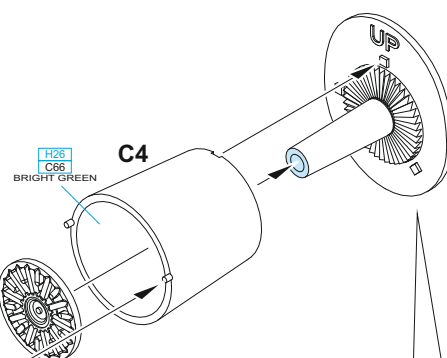
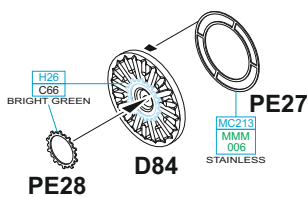
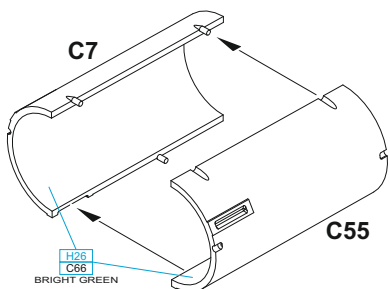
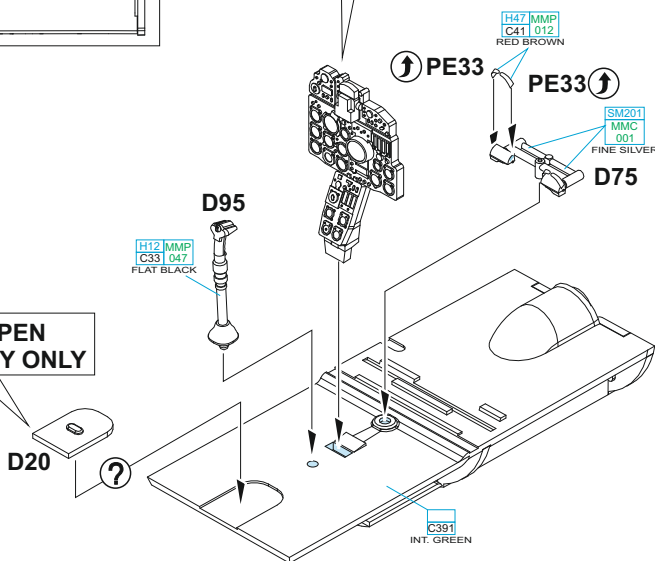

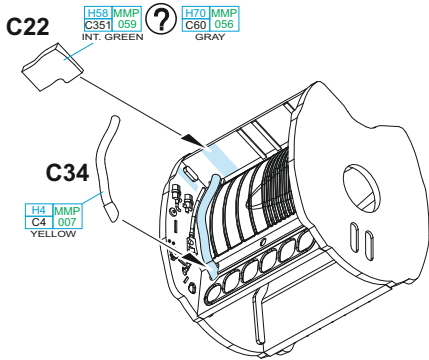
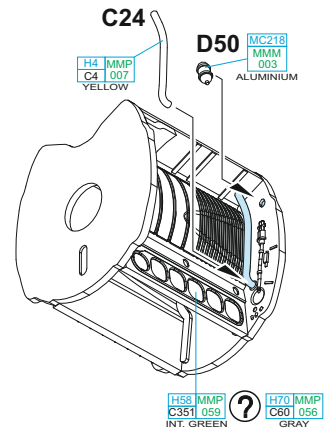
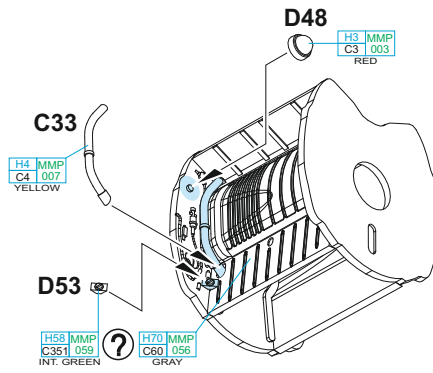
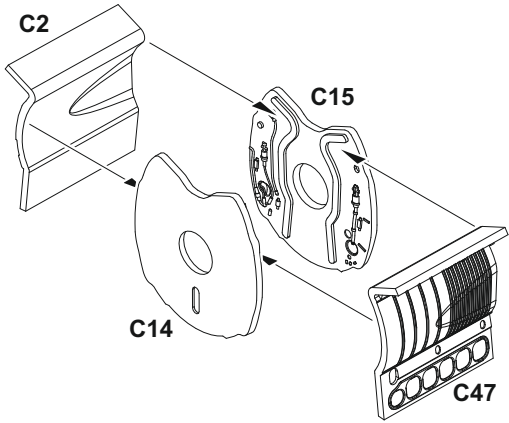

PE10 - MARKINGS A, B, C, E, F
PE11 - MARKING D

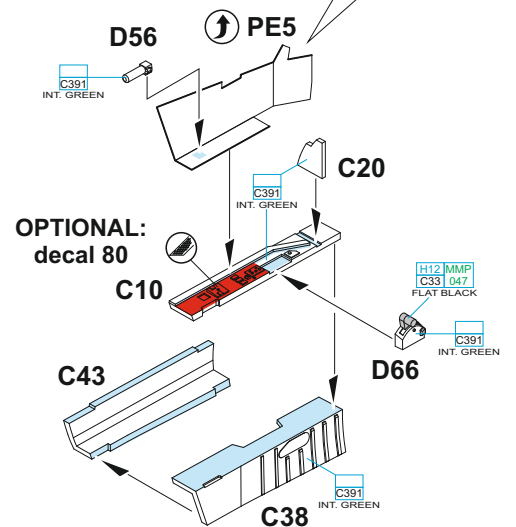
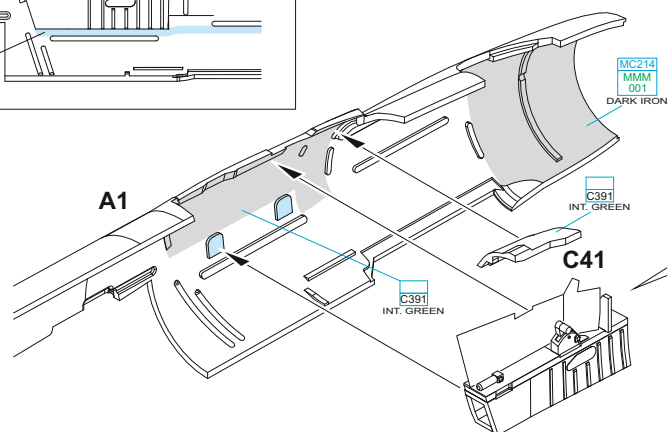
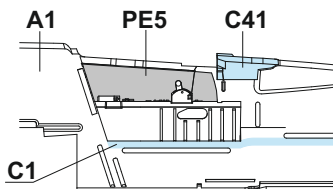
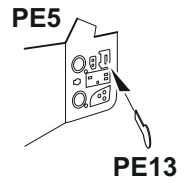
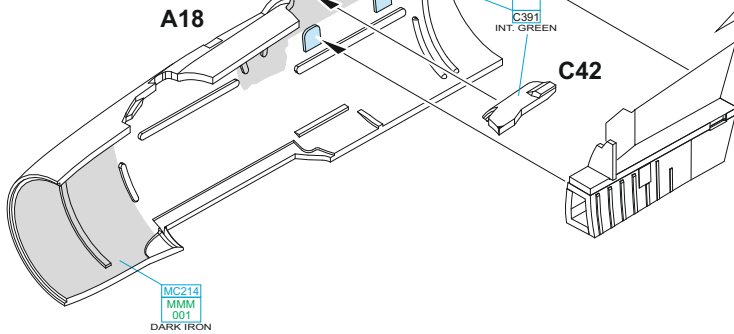
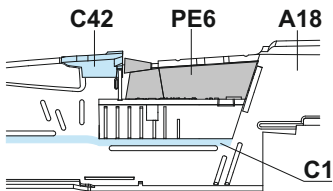
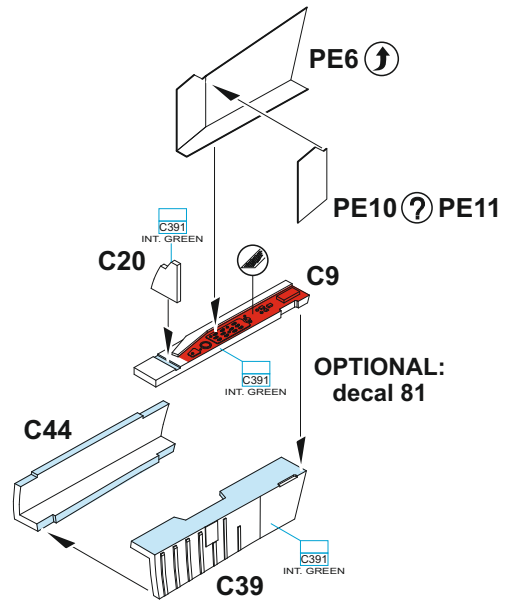

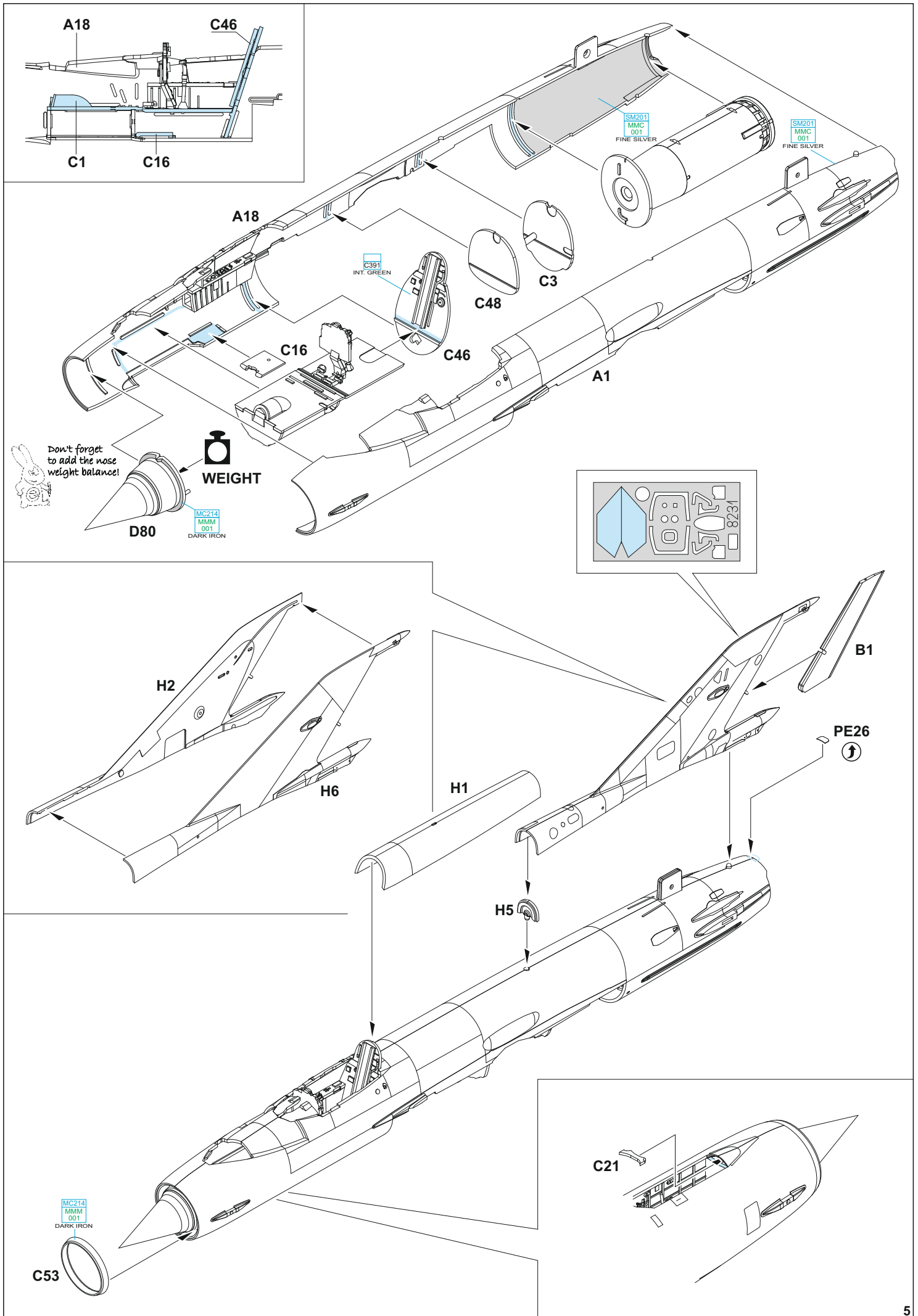

FOR OPEN AIR BRAKES ONLY

APPLY MASK OUTSIDE WHEN PAINTING

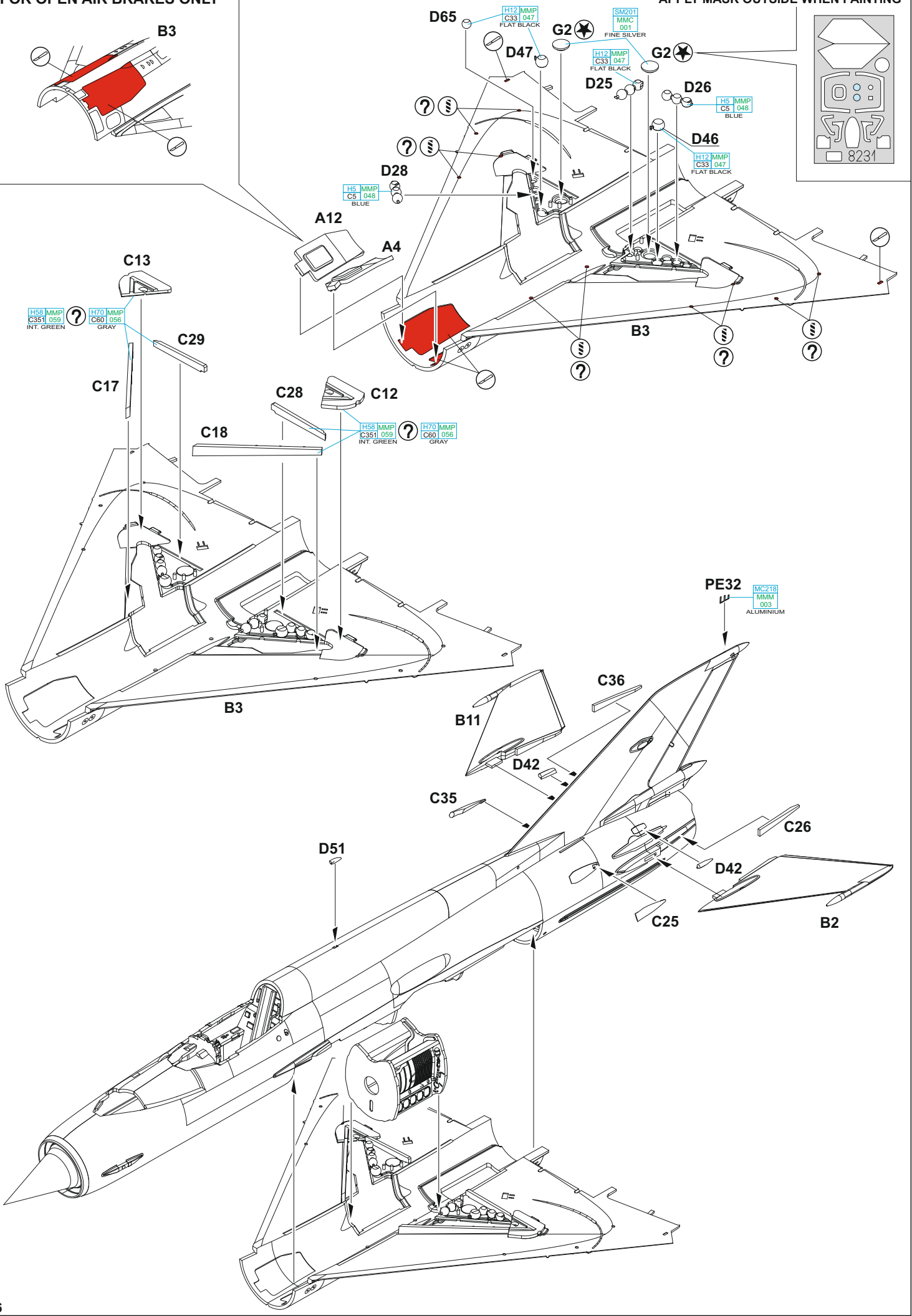
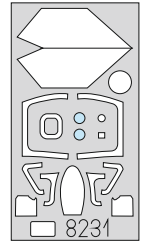
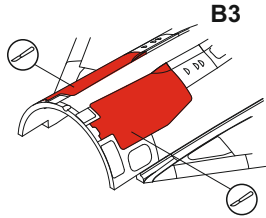

SCRIBE THE PANEL OR APPLY DECAL S170

MARKINGS A B C E F ONLY

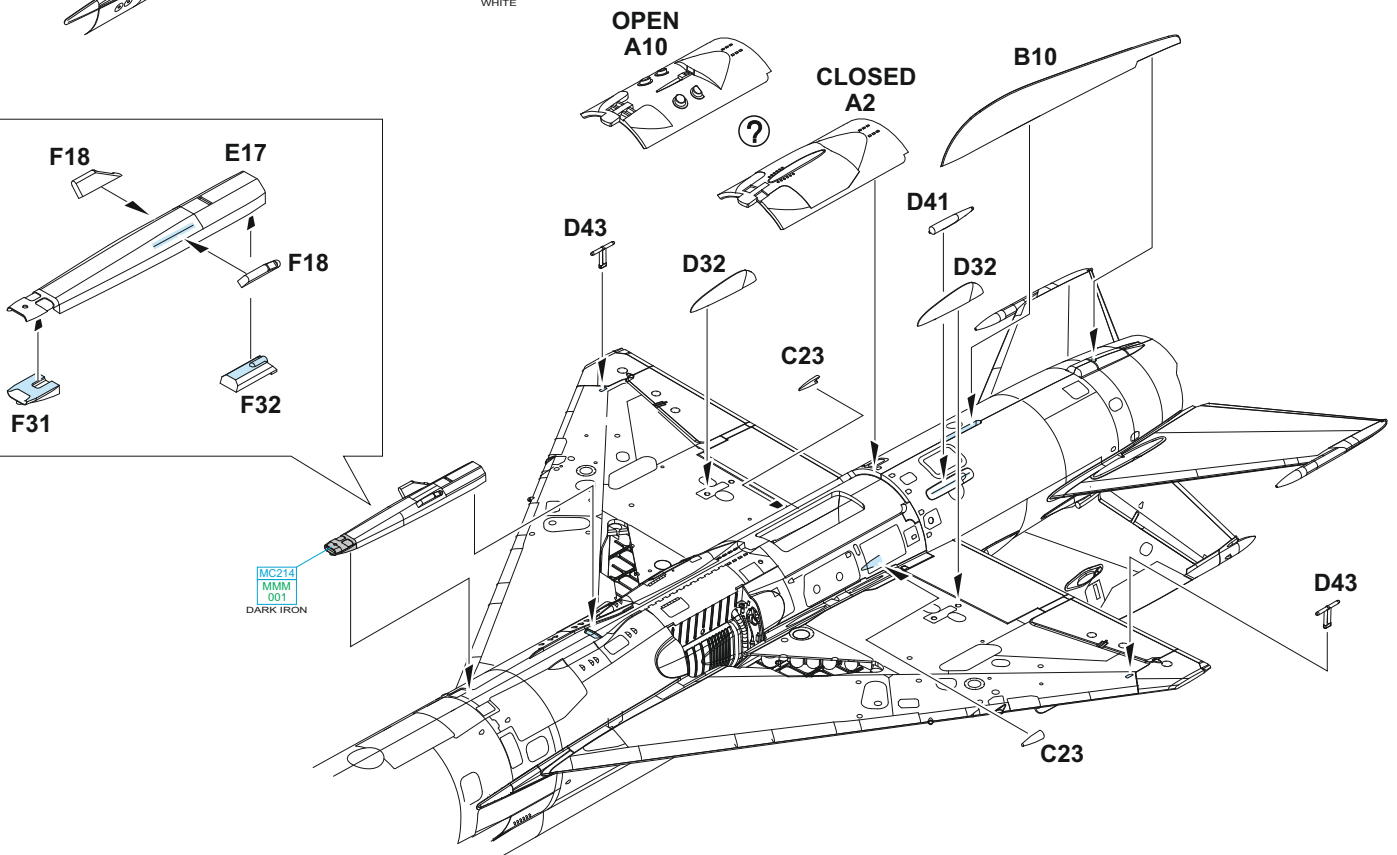
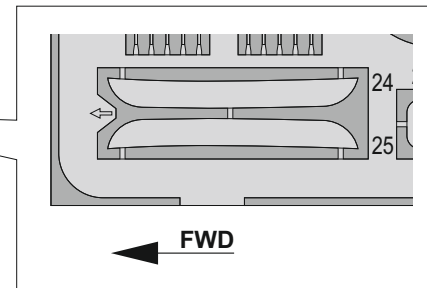
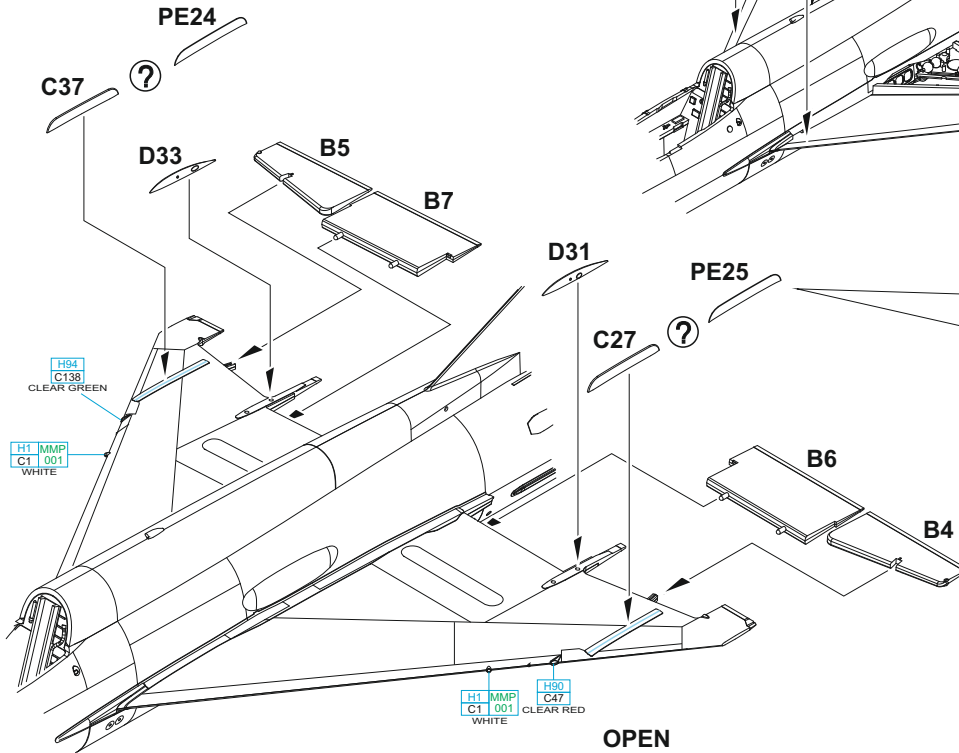
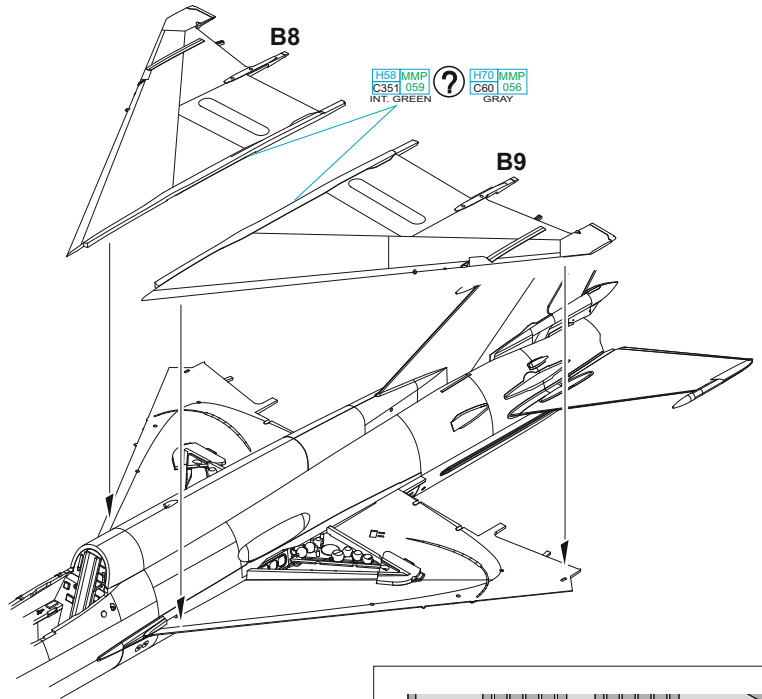
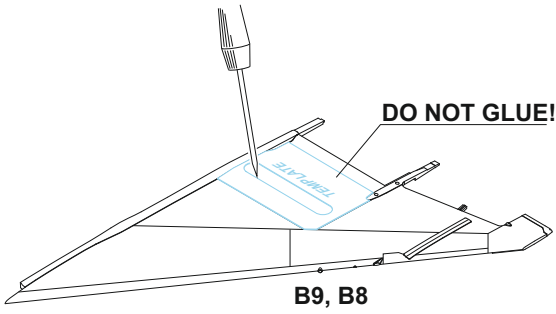

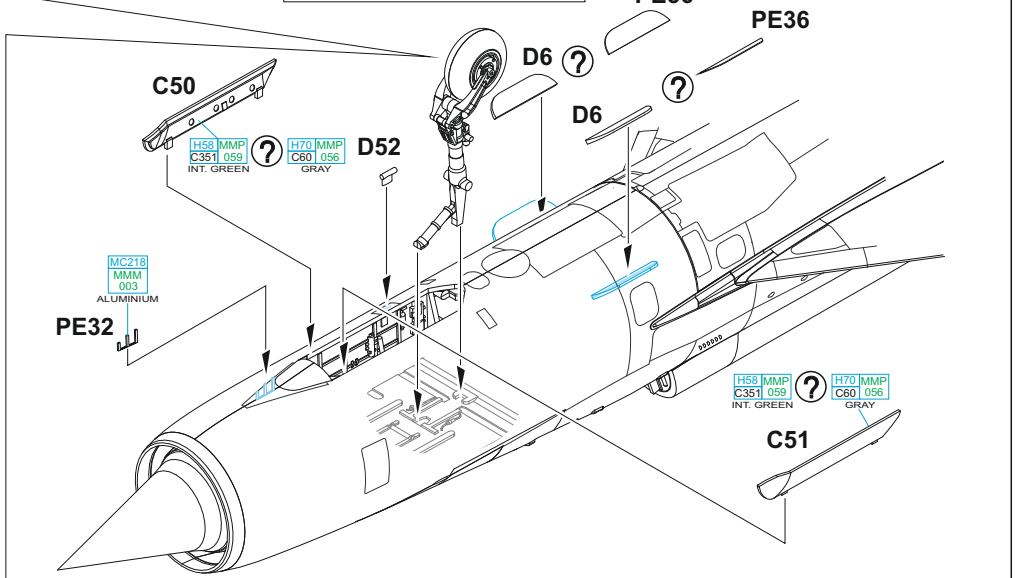
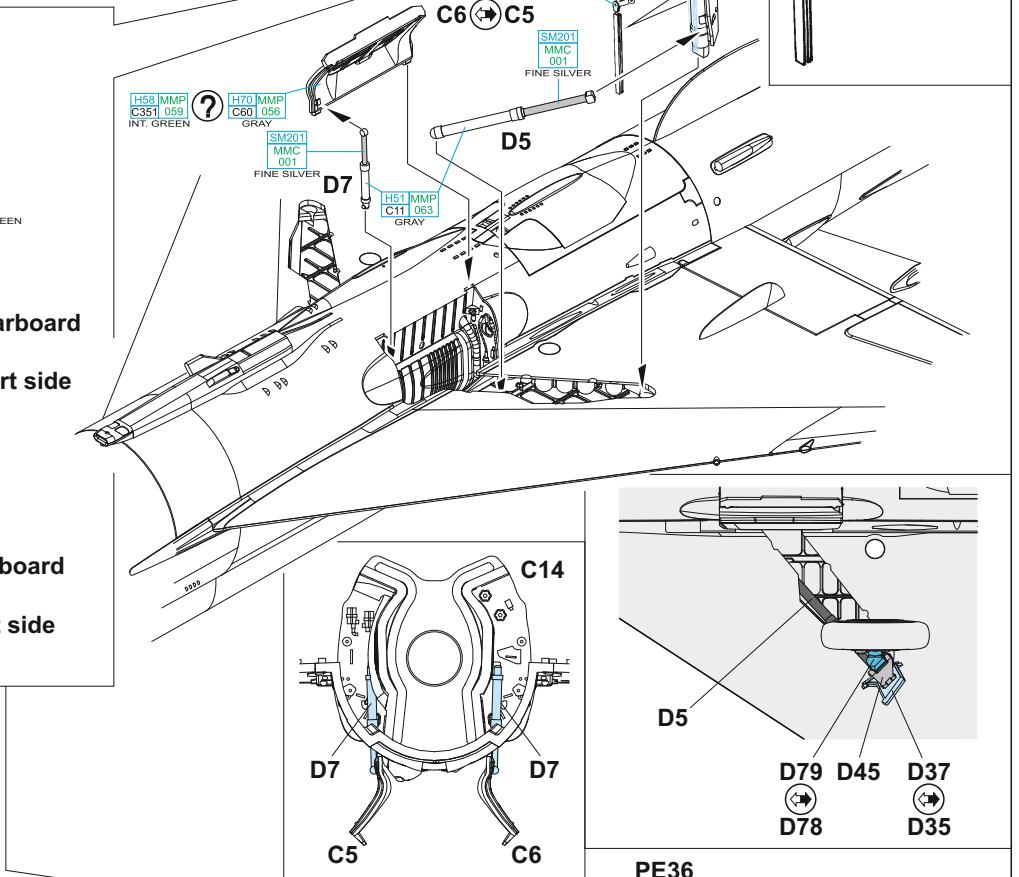
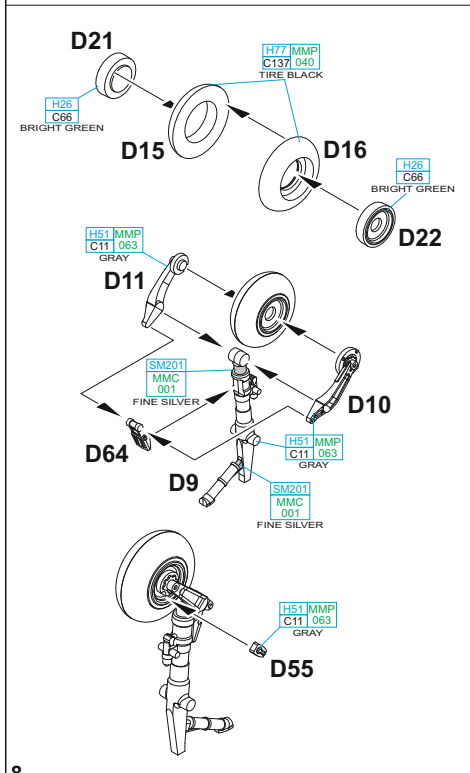
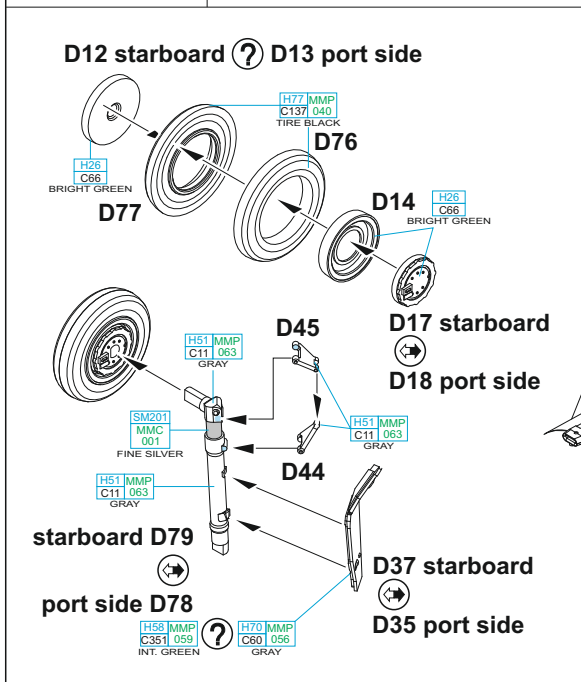
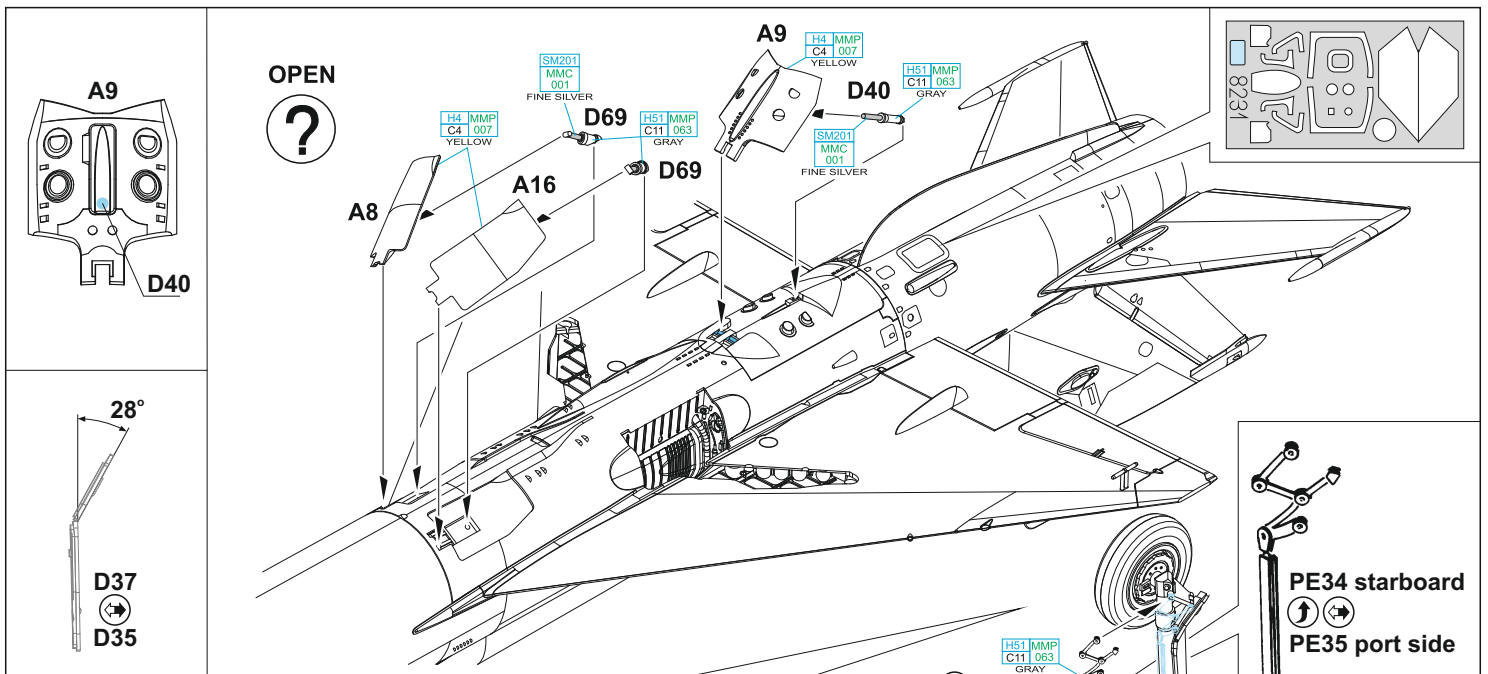

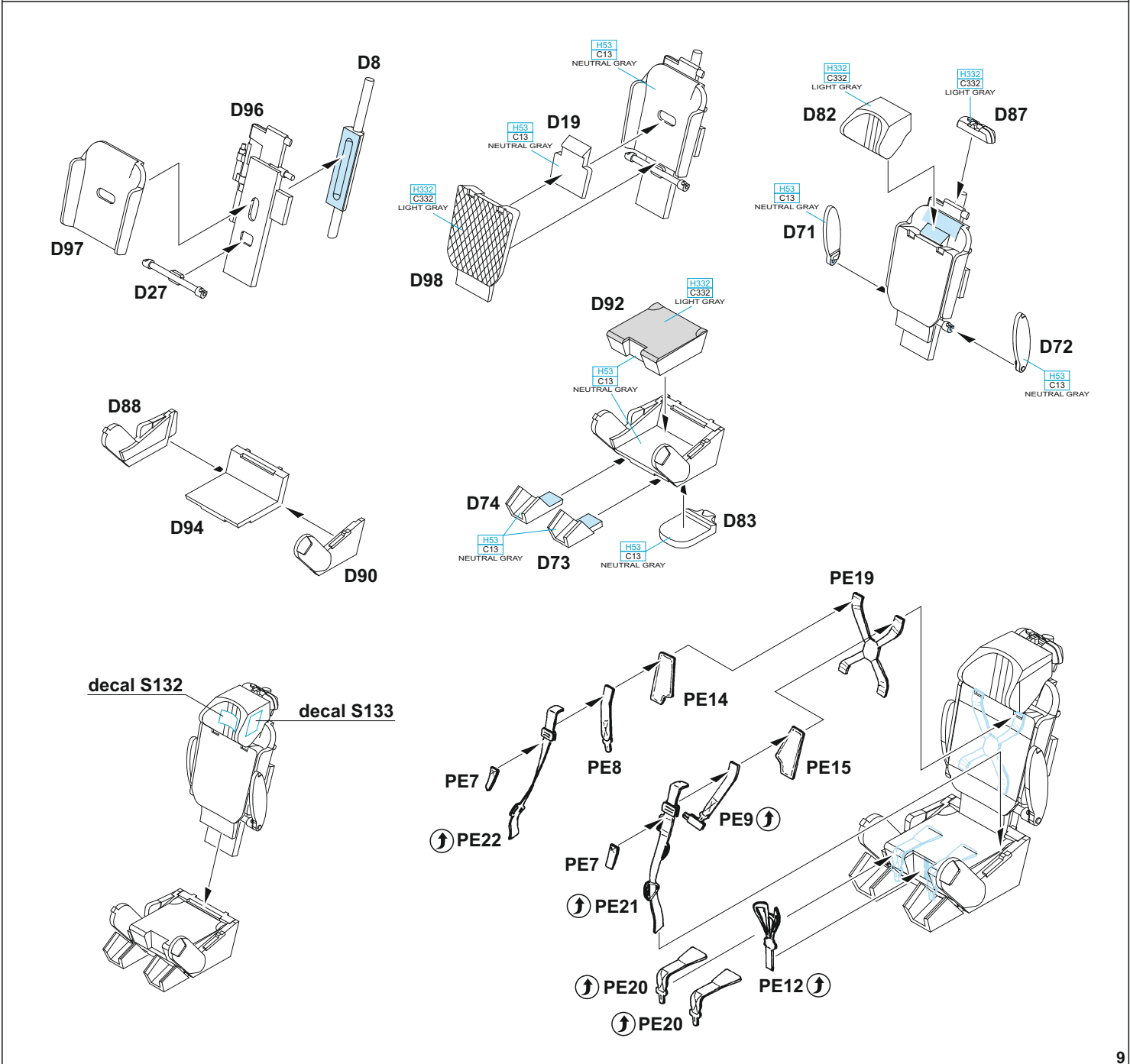
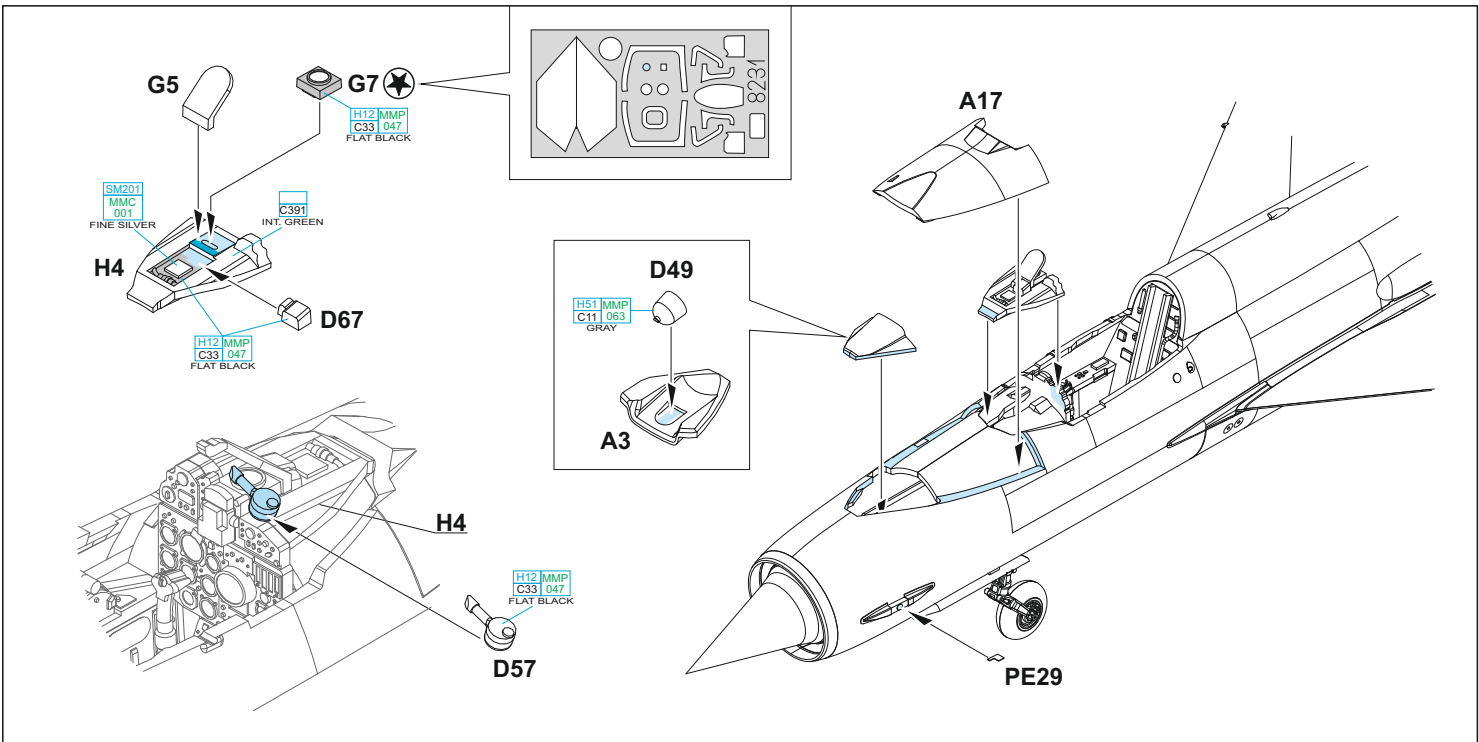

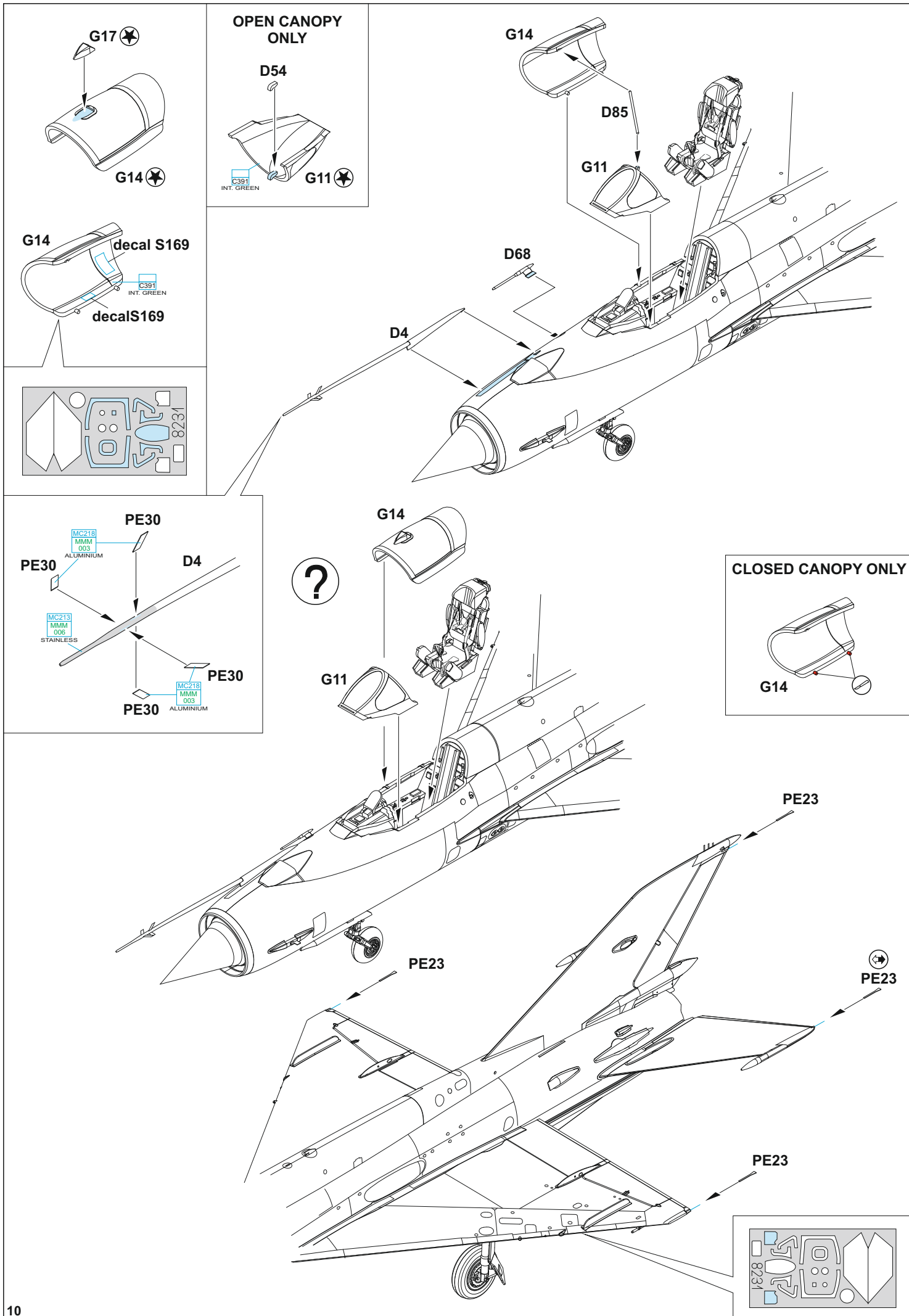

EXTERNAL FUEL TANK 800I

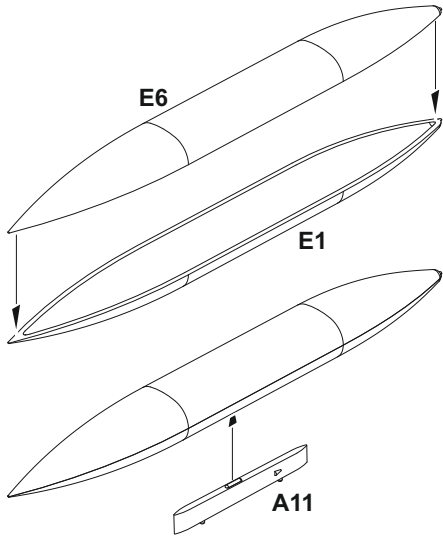

EXTERNAL FUEL TANK 490I
2 pcs.

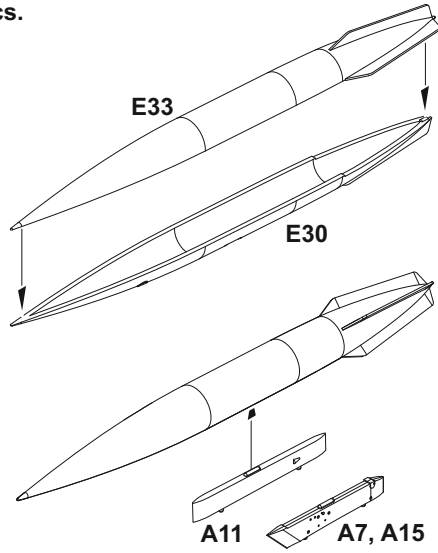

S-24
2 pcs.

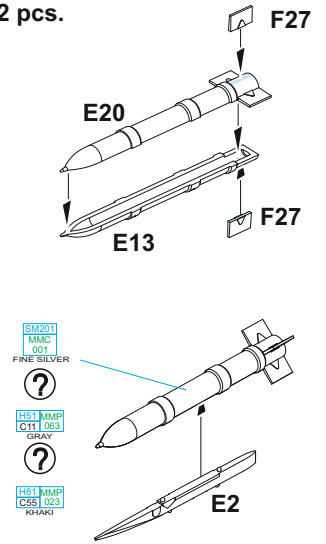

RS-2US
2 pcs.

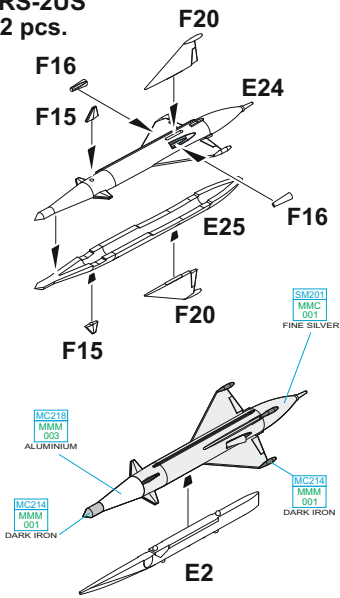

R-3S
2 pcs.

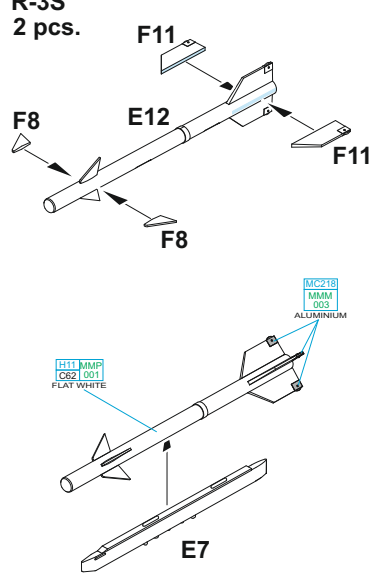

R-13
2 pcs.

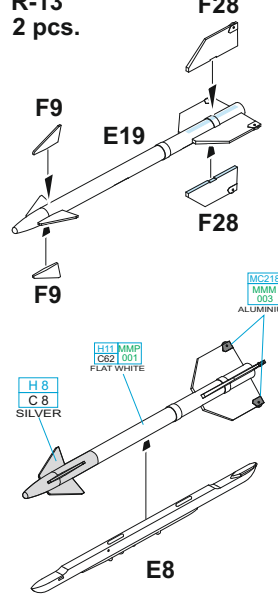

R-3R
2 pcs.

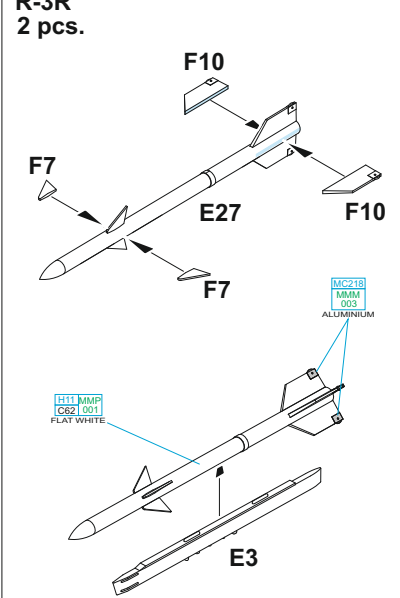

FAB 100 BOMB
8 pcs.

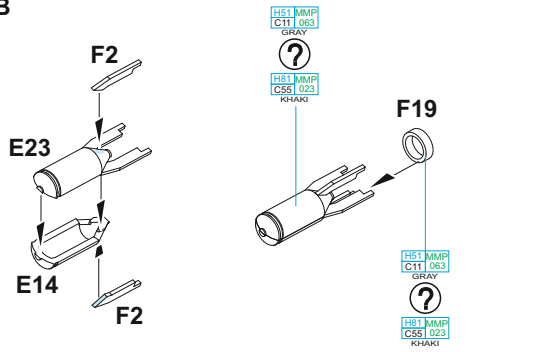

MBD FOR 4x FAB 100
2 pcs.

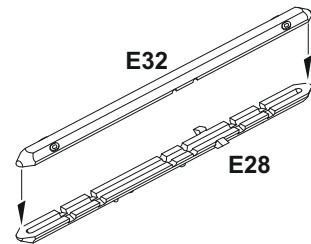

FAB 250 BOMB
2 pcs.

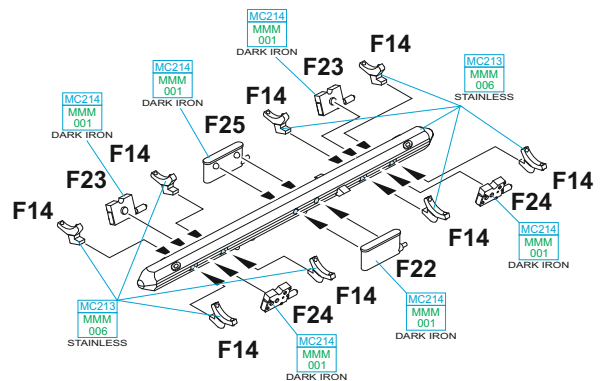
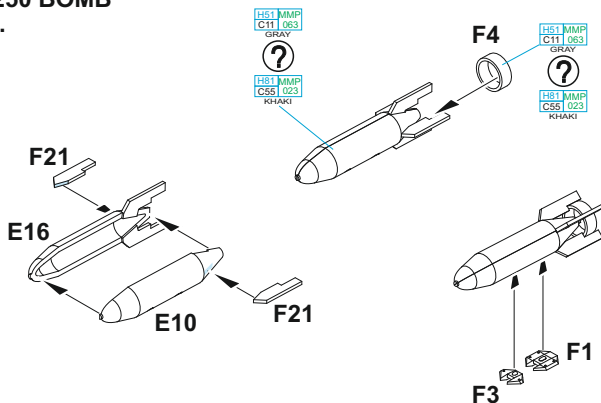

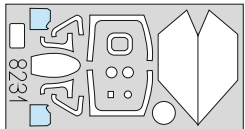
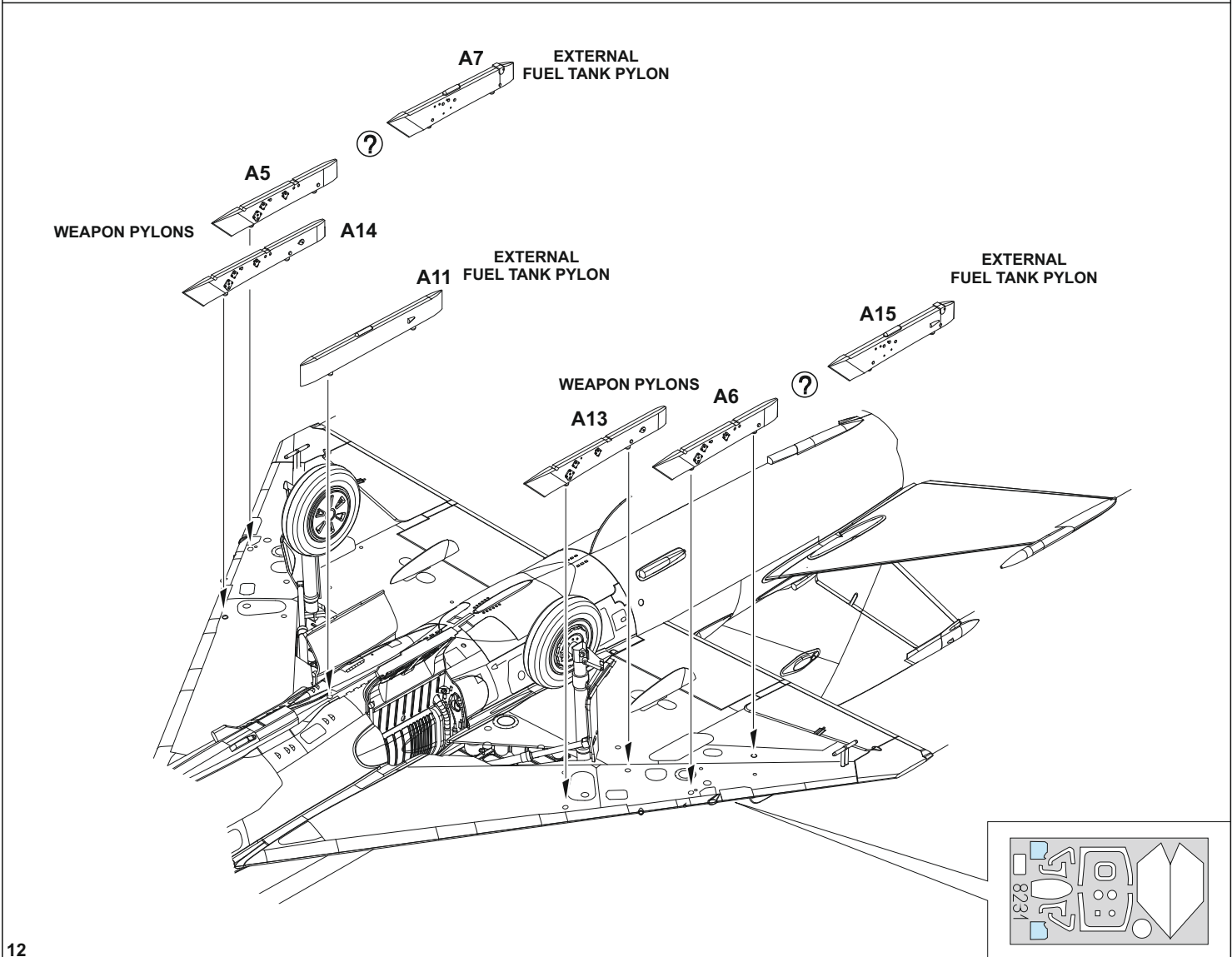
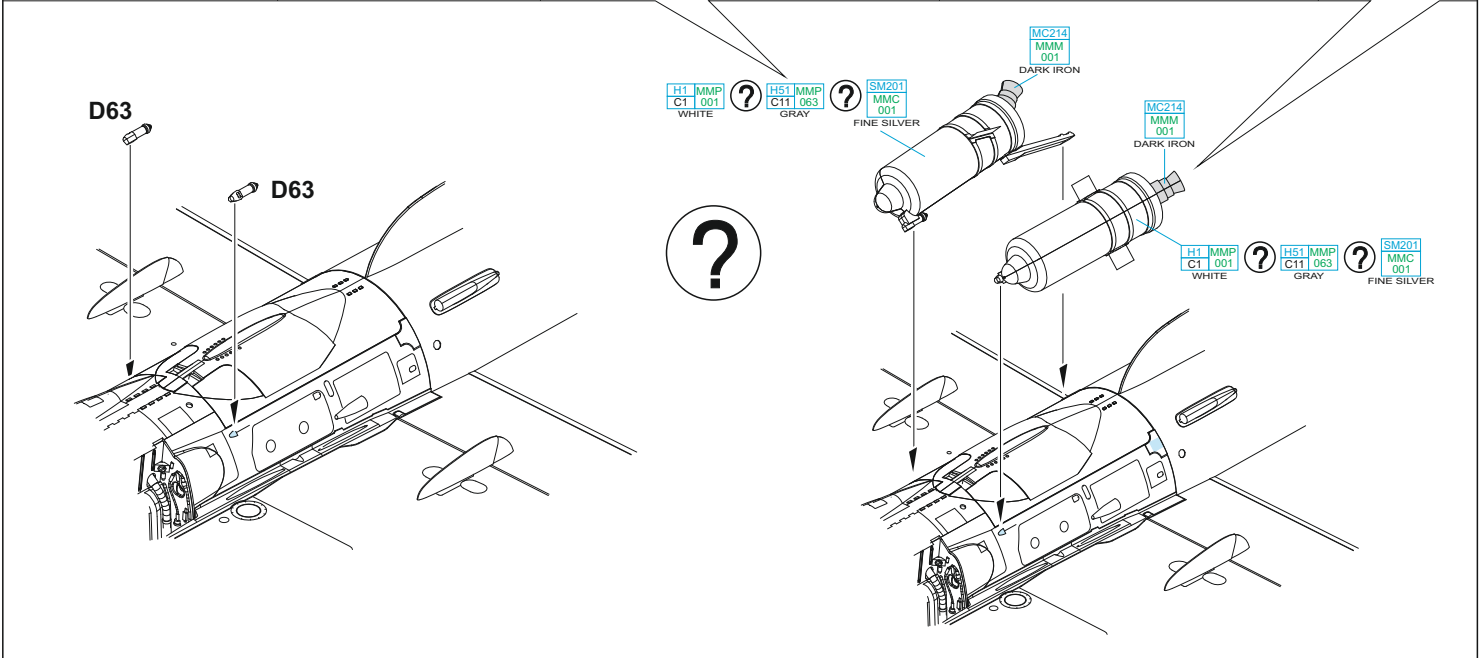
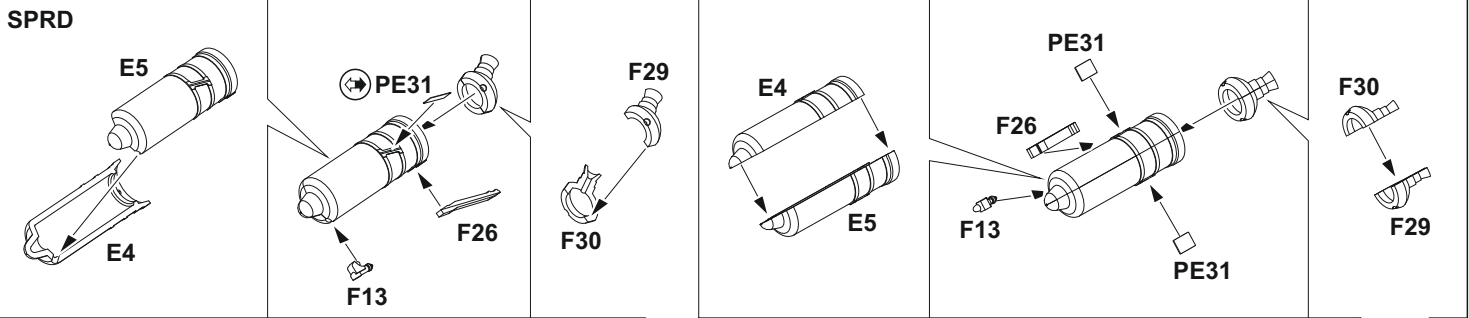

EXTERNAL FUEL TANK 800I

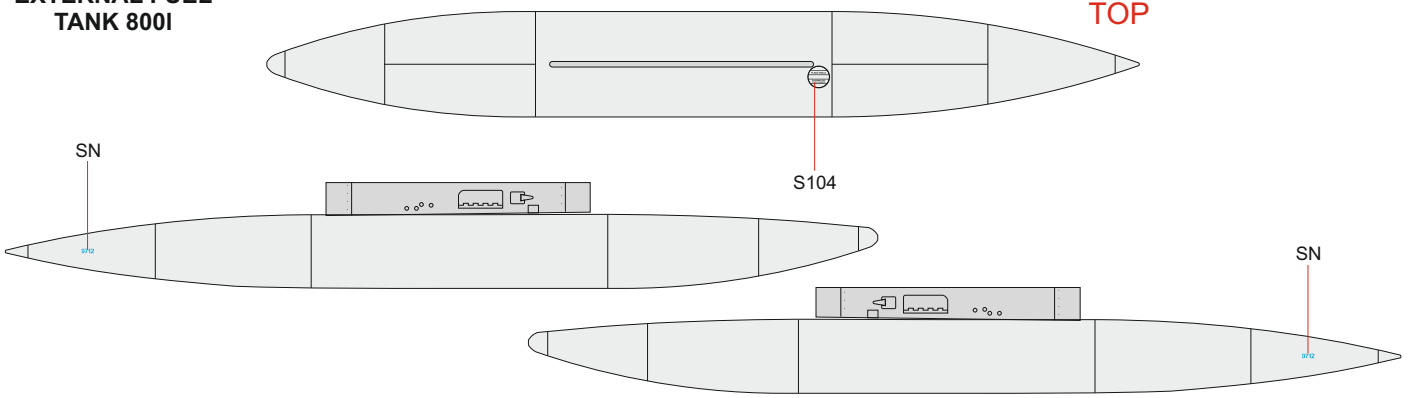

EXTERNAL FUEL TANK 490I

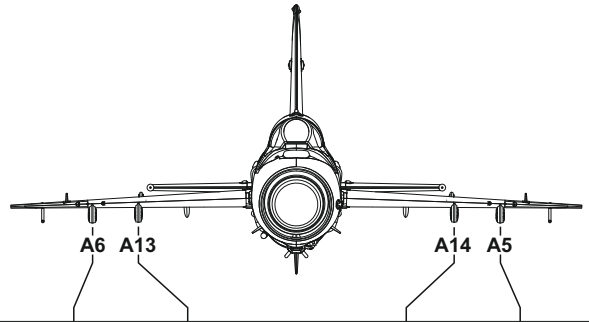
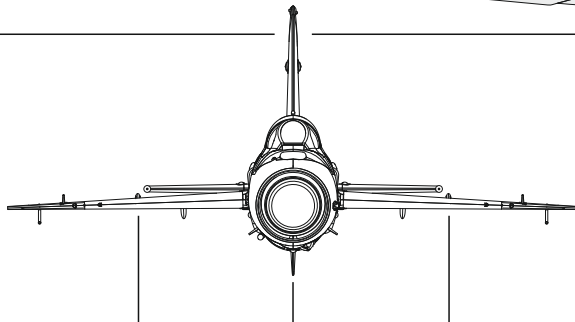
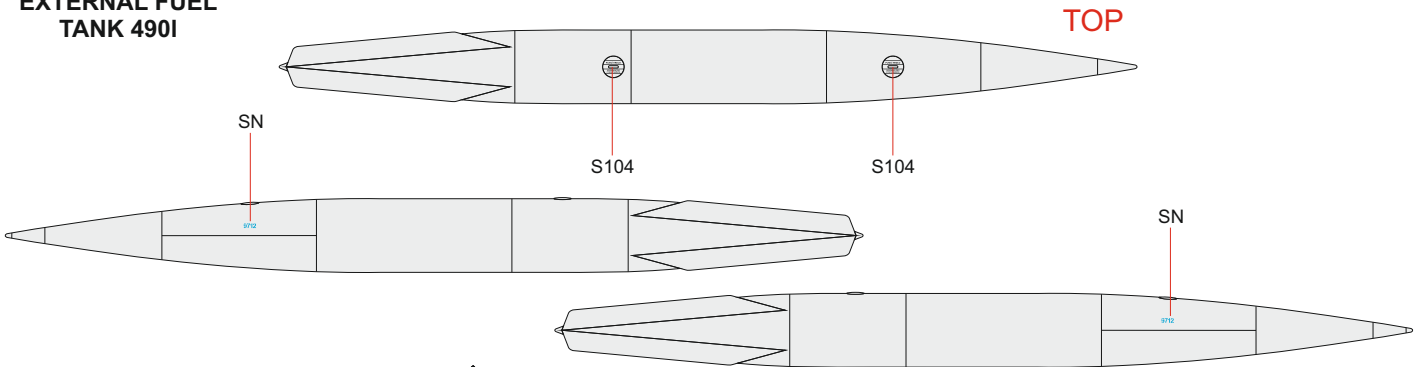

EXTERNAL FUEL TANK 800I	A11
EXTERNAL FUEL TANK 490I	A11
EXTERNAL FUEL TANK 490I	A15 A7

S-24	E2 E2 E2 E2
RS-2US	E2 E2 E2 E2
R-3S	E7 E7 E7 E7
R-13	E8 E8 E8 E8
R-3R	E3 E3
MBD	(Bomb icons)
FAB 100 BOMB	(Bomb icons)
FAB 250 BOMB	F1, F3 F1, F3

TO CHOOSE WEAPON AND EXTERNAL FUEL TANK OPTION PLEASE FOLLOW YOUR REFERENCE.

A MiG-21MF, No. 7628, Egyptian Air Force, Tanta AB, Arab Republic of Egypt, 1988

Aircraft No. 7628 represents the appearance of Egyptian military aircraft that are known through to the present day. The black outlined bright orange fields appeared on Egyptian aircraft at the end of the seventies, not only on the MiG-21s, but also on other fighters such as the MiG-19, F-4 Phantom and Mirage. The reason for this practice was better visual recognition of friendly aircraft in combat during the war with Libya.

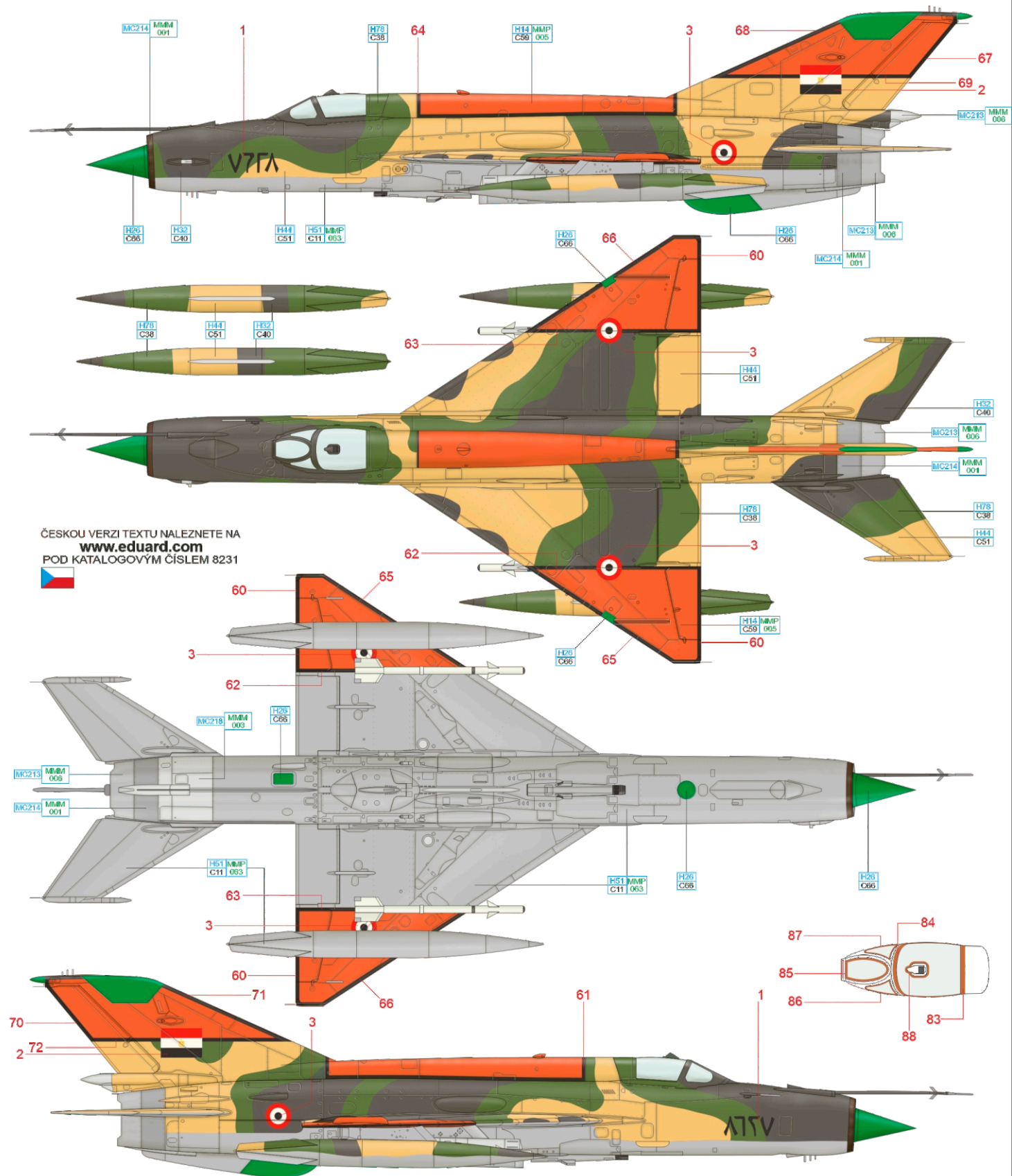

ČESKOU VERZI TEXTU NALEZNETE NA
www.eduard.com
 POD KATALOGOVÝM ČÍSLEM 8231



ALUMINIUM	MC218	MMM 003	FIELD GREY	H32	C40	BRIGHT GREEN	H26	C66	FLESH	H44	C51	OLIVE DRAB	H78	C38	LIGHT GREY	H51	MMP	C11	063	ORANGE	H14	MMP	C59	005
-----------	-------	---------	------------	-----	-----	--------------	-----	-----	-------	-----	-----	------------	-----	-----	------------	-----	-----	-----	-----	--------	-----	-----	-----	-----

B MiG-21MF, 9th Fighter Air Regiment, Bechyně AB, Czechoslovakia, 1989–1993

This aircraft was built in 1974 with serial number 969712 and was subsequently delivered to Czechoslovakia. It served with the 4th Fighter Regiment at Pardubice until it was transferred to the 9th Fighter Regiment based at Bechyně in May 1989. The aircraft was decorated with the coat of arms of the Bechyně city on the left side of the nose. After the dissolution of Czechoslovakia, this aircraft was assigned to the Slovak Air Force, and is currently in the collection of the Trenčín Air Museum. The aircraft sports the original camouflage scheme as it was delivered from the Soviet Union.

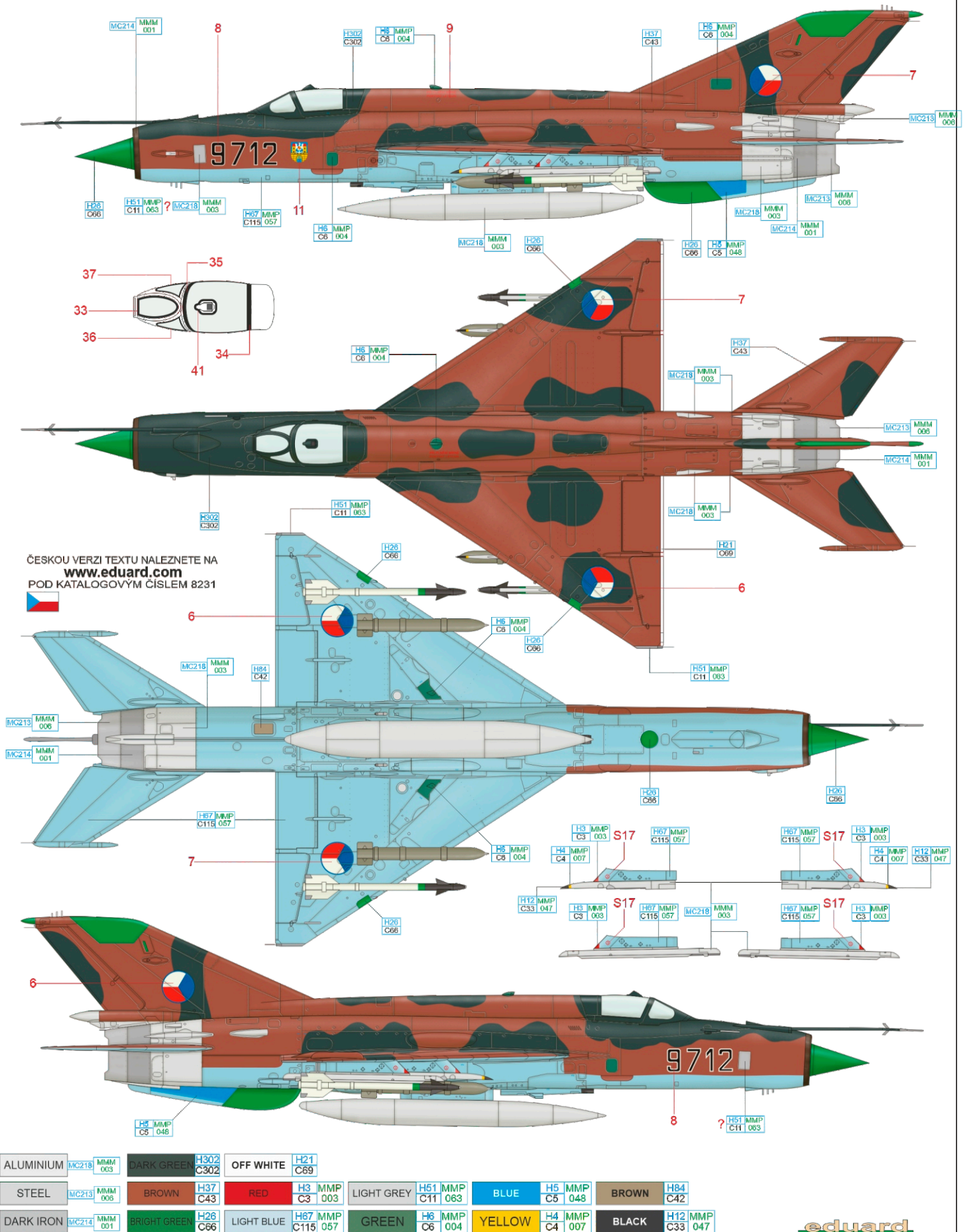

C MiG-21MF, 4th Squadron, 31st Fighter Wing, Sliač AB, Slovakia, July 1997

This unique camouflage scheme came about in July 1997, when 31st AFB Sliač personnel applied it to the aircraft with serial No. 967713, and subsequently dubbed it 'Milka' for its resemblance to the coloring of a cow. The aircraft flew into August 2000 and was scrapped at Přelouč in 2010. The individual shades in the painting scheme were derived by mixing black and white paints available to the general public, and as such, these were not any military standard paints. The left front carried the 4th Squadron emblem, the right carried the marking of the 31st AFB Sliač. The aircraft was flown by pplk. (LtCol.) Zsoldos, the crew chief for the aircraft was kpt. (Capt.) Krucina.

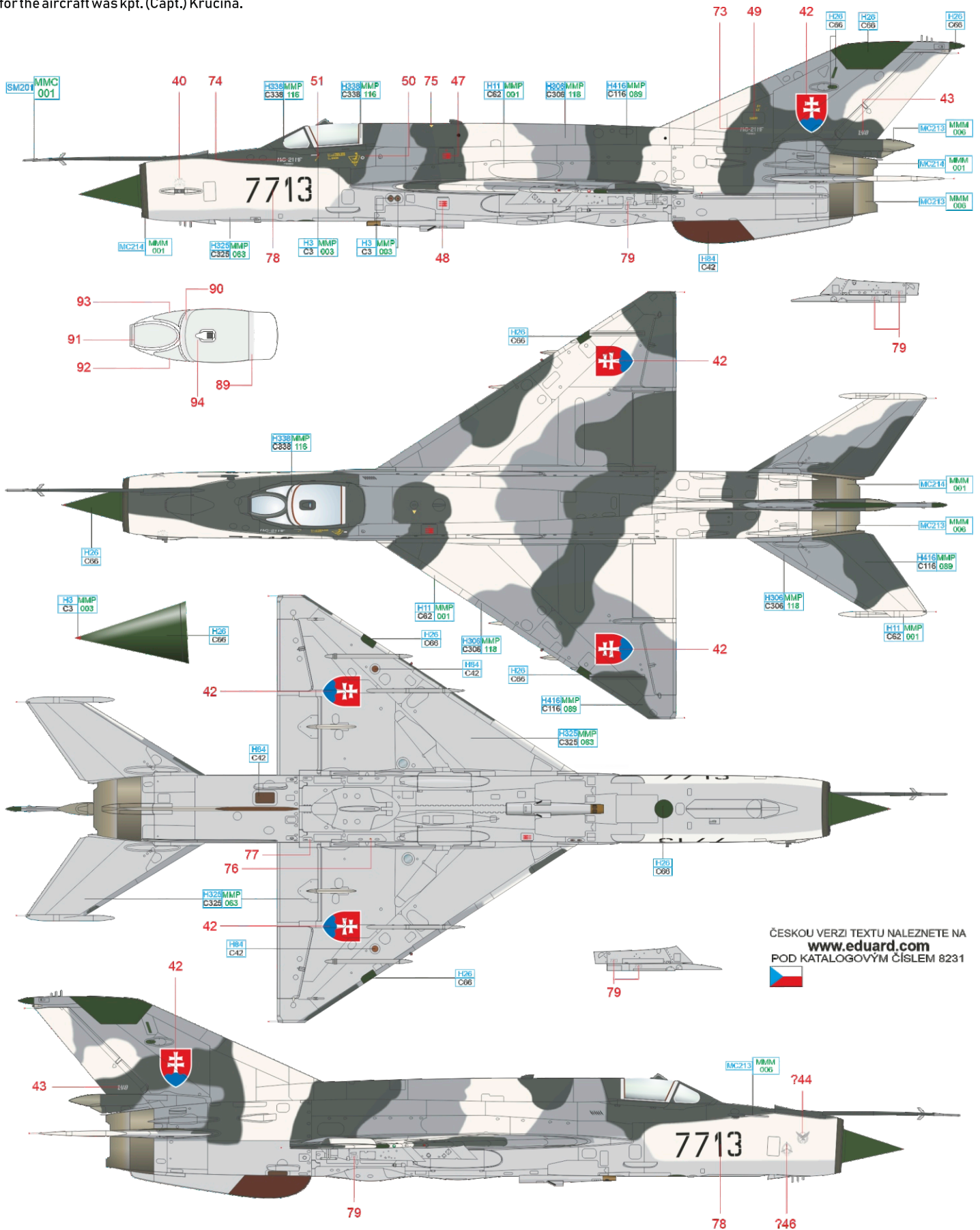

ČESKOU VERZI TEXTU NALEZNETE NA
www.eduard.com
 POD KATALOGOVÝM ČÍSLEM 8231

STEEL	MC213 MMM 006	MAHOGANY	H84 C42	BLACK	H416/MMP C116 089	LIGHT	H338/MMP C338 116	WHITE	H11 MMP C62 001
DARK	MC214 MMM 001	BRIGHT	H26 C66	RED	H3 MMP C3 003	MEDIUM	H306/MMP C306 118	GRAY	H325/MMP C325 063
								SUPER	SM201 MMC 001

D MiG-21MF, 10th Tactical Squadron, Lask AB, Poland, 2001–2003

At the turn of the century, Poland began to reequip its air force, moving from Soviet (and later Russian) aircraft to American machinery, namely Lockheed Martin F-16 Fighting Falcon. One of the MiG-21MFs that were at the time nearing the end of their service life was the No. 7809, serving with the 10th Tactical Squadron. This unit was based at Lask Air Base between 2001 and 2003.

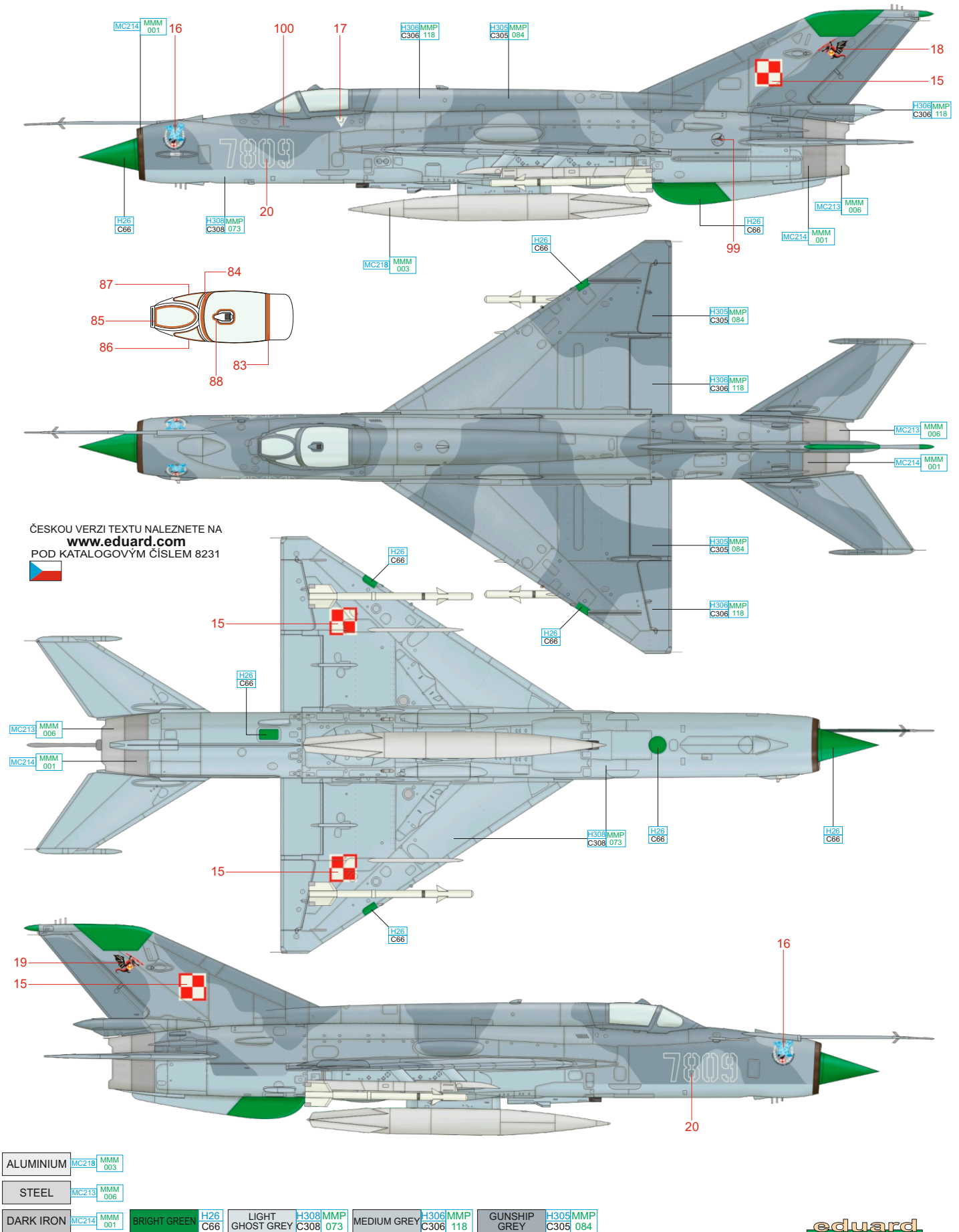

E MiG-21SM, 812th UAP, Kharkov Higher Military Academy, Kupyansk AB, Soviet Union, August 1991

This aircraft, adorned with a shark mouth and eyes, served with the 812th UAP (Training Regiment), operating within the structure of the Kharkov higher military academy. This MiG-21SM was among the aircraft displayed during the open house day on August 18, 1991.



ČESKOU VERZI TEXTU NALEZNETE NA
www.eduard.com
 POD KATALOGOVÝM ČÍSLEM 8231

ALUMINIUM	MC218	MMM 003	BRIGHT GREEN	H26	C66	LIGHT BLUE	H67	MMP	C115	057	MID STONE	H71	MMP	C21	076	GREEN	H302	C302
STEEL	MC213	MMM 006																
DARK IRON	MC214	MMM 001																

F MiG-21MF, Jagdfliegergeschwader 3, Preschen AB, German Democratic Republic, 1990

Red '687' was assigned to JG-3 based at Preschen air base near the town of Forst through the eighties and into the nineties. At that time, the unit operated the MiG-21MFs as well as the MiG-29s, and pilots also had the MiG-21UM and MiG-29UB available for training flights. The unit, which was the part of the air force of the German Democratic Republic, also known as East Germany, was graced with the name 'Wladimir Komarow', in honor of the Soviet cosmonaut who died on April 24, 1967, during the landing after return from the orbit in the Soyuz 1 capsule. This aircraft is part of the collection of the Deutsches Museum Flugwerft in Oberschleissheim.

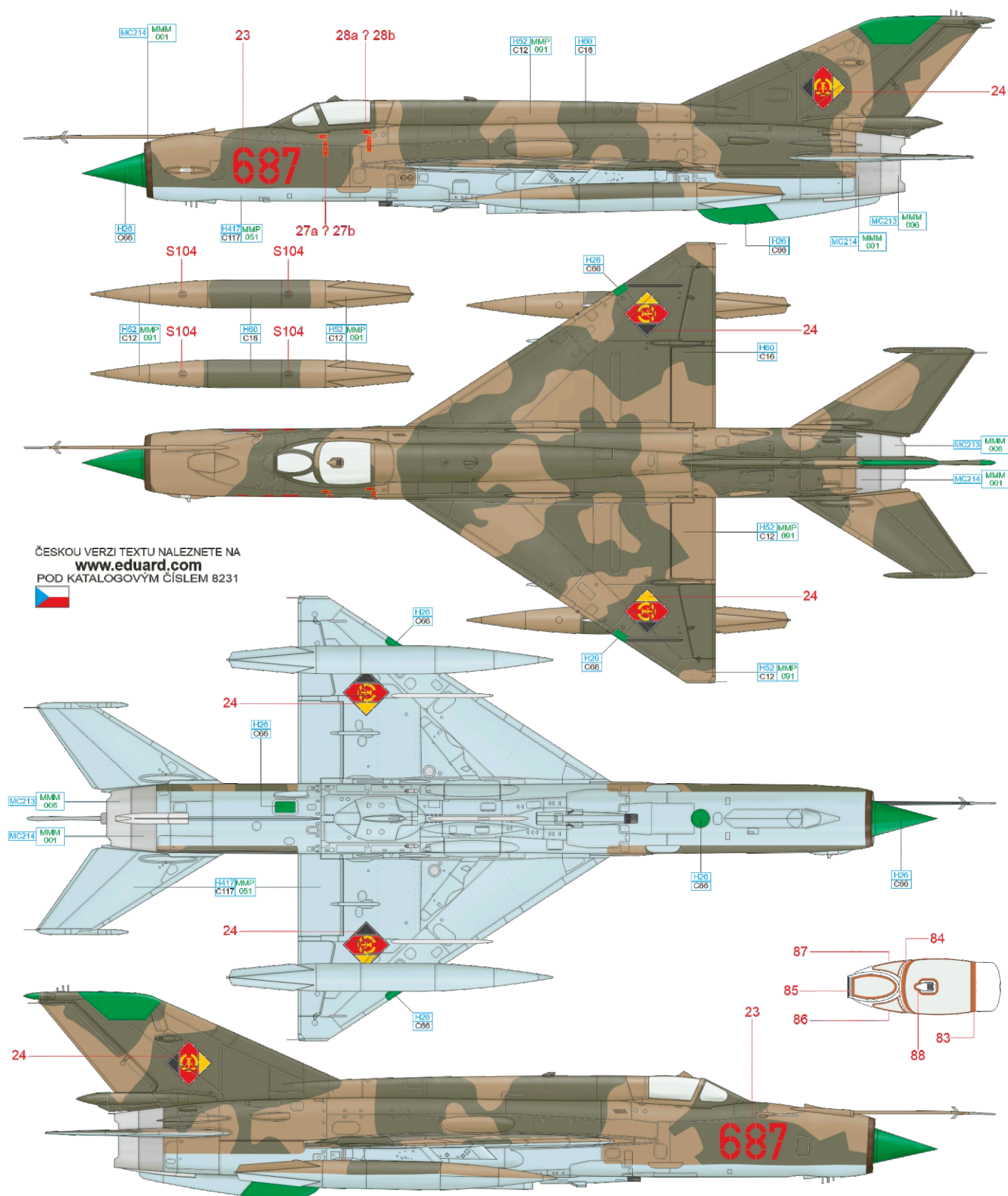

ČESKOU VERZI TEXTU NALEZNETE NA
www.eduard.com
 POD KATALOGOVÝM ČÍSLEM 8231



STEEL	MC213	MMM 006
DARK IRON	MC214	MMM 001

BRIGHT GREEN H26 C66

LIGHT BLUE H417 MMP C117 051

OLIVE DRAB H52 MMP C12 091

DARK GREEN H60 C16

eduard

Pro letouny kamuflované jsou určeny popisky červené a modré, pro letouny v barvě kovu nebo šedé použijte popisky červené a černé.
 Camouflaged aircraft - red and blue stencils. Natural metal and grey aircraft - red and black stencils.

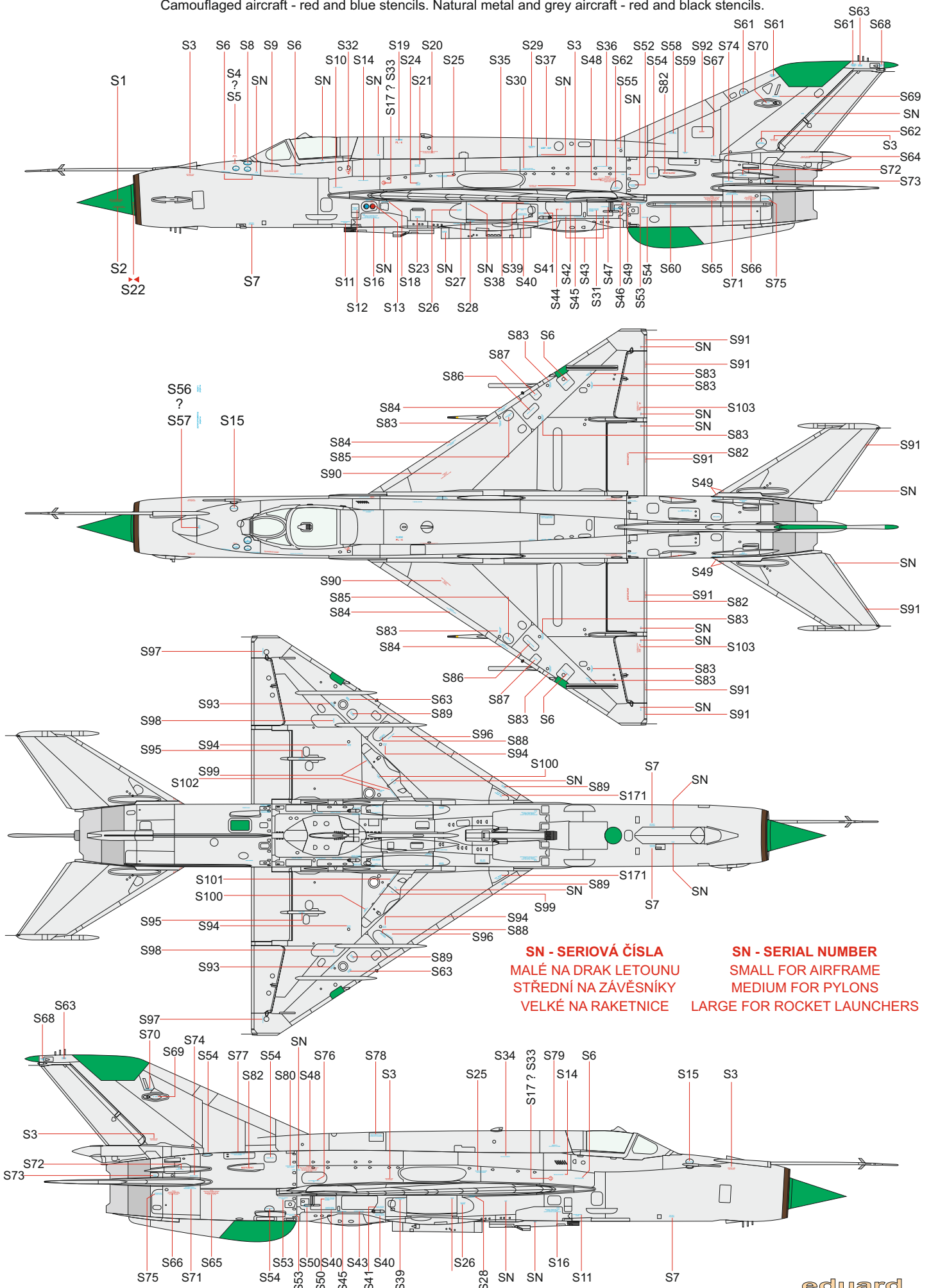

SN - SERIOVÁ ČÍSLA
 MALÉ NA DRÁK LETOUNU
 STŘEDNÍ NA ZÁVĚSNÍKY
 VELKÉ NA RAKETNICE

SN - SERIAL NUMBER
 SMALL FOR AIRFRAME
 MEDIUM FOR PYLONS
 LARGE FOR ROCKET LAUNCHERS