

SOVIET SUPERSONIC FIGHTER 1:48 SCALE PLASTIC KIT



eduard

ProfiPACK



intro

The MiG-21 was one of a long list of Mikoyan-Gurevich products to be integrated into the armed forces of the Soviet Union, the Warsaw Pact, and allied client states. Its predecessors included such notable types as the MiG-15, MiG-17 and the supersonic MiG-19. The roots of this project reach back to the first half of the fifties. In 1954, the Ye-1 project came to an end, and was quickly picked up by the Ye-2. Both had a swept wing. The first machine to feature the delta wing was the Ye-4, which first took to the air on June 16th, 1955. It was also demonstrated a year later at the Moscow airfield Tushino. The first of the new line to enter production was the MiG-21F, which together with the MiG-21P and F-13 represented the first generation of the MiG-21, and was in production through the end of the fifties and the beginning of the sixties. Subsequent versions included the PF, FL, PFM, R, S, N and PD, the production of which peaked at the end of the sixties. The third generation started production in 1968, which included such versions as M, SM, MF, SMT, bis among others. Simultaneously, two-seat training versions were also produced designated MiG-21U, UM and US. Production of the MiG-21 ended in 1985, and was put into service with some fifty nations. Over the course of the cold war, the opponents of the MiG-21 included the likes of the Northrop F-5 Freedom Fighter and the Dassault Mirage III. NATO assigned it the reporting name 'Fishbed'. It became the most produced supersonic fighter in terms of quantity. The new machines came off Soviet production lines in Moscow, Gorky and Tbilisi. The MiG-21F-13 was also built under license in Czechoslovakia and the MiG-21FL, M and bis in India by Hindustan Aeronautics Ltd. The Soviet Union produced 10, 645 examples of all versions, 194 were built in Czechoslovakia and 657 in India. Outside of the Soviet Union, the type flew with a long list of nations on all continents with the exception of Australia. The MiG-21 participated in combat in Vietnam, the Indo-Pakistan wars, the Cuban participation in Angola and in the Arab world's attempt to eliminate Israel. Thanks to the high volume of use, the highest number of aces produced on the type was in Vietnam. The top of the ladder is occupied by Nguyen Van Coc with nine kills. The type serving as a fighter-bomber served with the Soviet Union and other nations of the Warsaw Pact into the eighties, when it began to be displaced by the MiG-29 Fulcrum.

This kit is specific to the building of a model of the MiG-21PF. In factory documentation, the export version is identified as 'Izdelye 76A' and the version built for Soviet armed forces as 'Izdelye 76'. It was powered by a Tumanskiy R-11F2-300. Hardpoints could still be loaded with RS-3US, R-3S missiles and UB-16-57 rocket pods, S-24 unguided rockets and bombs up to 500kg in size. NATO assigned MiG-21PF the codename 'Fishbed D'.

úvodem

MiG-21 byl další konstrukcí kanceláře Mikojan-Gurjevič, která se zařadila do výzbroje Sovětského svazu, zemí Varšavské smlouvy a dalších ozbrojených sil. Jeho předchůdci byly tak významné typy jako MiG-15, MiG-17 či nadzvukový MiG-19. Kořeny vývoje letounu sahají do první poloviny 50. let minulého století. V roce 1954 byl dokončen projekt Je-1, velmi rychle nahrazený druhým prototypem Je-2. Oba měly šípové křídlo. Prvním strojem s delta křídlem byl prototyp Je-4, který se do vzduchu dostal poprvé 16. června 1955. Představil se také na letecké přehlídce, která se konala o rok později na moskevském letišti Tušino. Jako první se do sériové výroby dostala verze MiG-21F, která společně s MiG-21P a MiG-21F-13 reprezentovala první generaci tohoto typu, vyráběnou na přelomu 50. a 60. let minulého století. Následovaly další, pokročilejší verze – PF, FL, PFM, R, S, N a PD, jejichž produkce vyvrcholila ve druhé polovině 60. let. Od roku 1968 probíhala výroba třetí generace, která zahrnovala například verze M, SM, MF, SMT, bis a další. Souběžně se stavěly také dvoumístné cvičné jednadvacítky MiG-21U, UM a US. Výroba MiGů-21 skončila v roce 1985 a do výzbroje je zařadilo okolo 50 zemí světa. MiG-21 měl během studené války své protějšky v typech Northrop F-5 Freedom Fighter či Dassault Mirage III. Vojska NATO dalo typu kódové označení Fishbed. Stal se v největších počtech vyráběným nadzvukovým letounem. Nové stroje v Sovětském svazu sjížděly z továrních linek v Moskvě, Gorkém a Tbilisi. V licenci se stavěla verze MiG-21F-13 v Československu a MiG-21FL, M a bis v Indii u Hindustan Aeronautics Ltd. V Sovětském svazu vzniklo 10 645 exemplářů všech verzí, v Československu 194 kusů a v Indii 657 strojů. Kromě ozbrojených sil Sovětského svazu létal v řadě zemí, s výjimkou Austrálie na všech kontinentech. Zúčastnil se řady válečných konfliktů, včetně války ve Vietnamu, indicko-pákistánských potyček, kubánského tažení v Angole či arabské snahy o zničení Izraele. Díky největšímu zapojení do bojových akcí se největší počet stíhacích es zrodil ve Vietnamu. Na čele žebříčku stojí Nguyen Van Coc s devíti sestřely. V roli přepadového stíhacího letounu sloužily MiGy-21 v Sovětském svazu a dalších zemích Varšavské smlouvy až do 80. let, kdy jej jako plnohodnotná náhrada začaly z prvoliniové služby vytlačovat nové MiGy-29 Fulcrum.

Z této stavebnice je možné postavit MiG-21PF. V tovární dokumentaci figuruje pod označením Izdělje 76A pro exportní stroje a Izdělje 76 pro letouny určené pro sovětské ozbrojené síly. Poháněl jej motor Tumanskiy R-11F2-300. Podvěsnou výzbroj tvořily rakety RS-3US, R-3S, popř. raketové bloky UB-16-57, protizemní neřízené rakety S-24 a pumy do 500 kg. V kódu NATO nesly stroje označení Fishbed D.

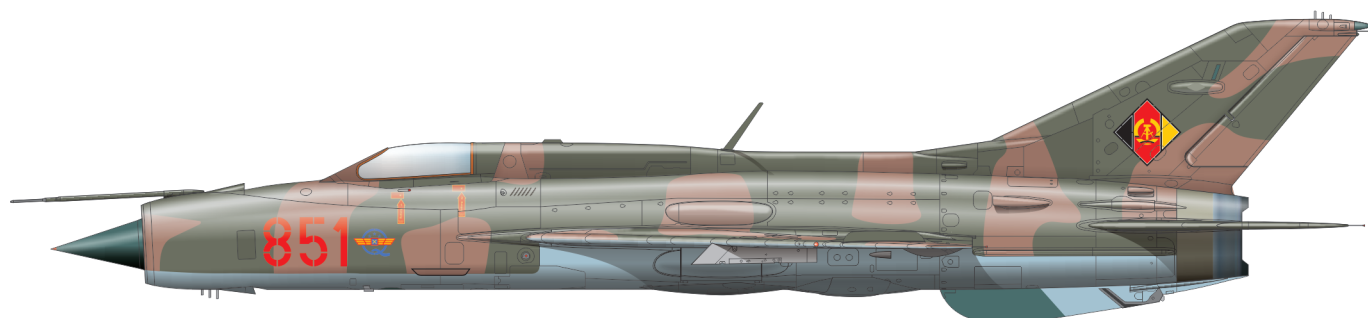



Carefully read instruction sheet before assembling. When you use glue or paint, do not use near open flame and use in well ventilated room. Keep out of reach of small children. Children must not be allowed to suck any part, or pull vinyl bag over the head.



Před započítím stavby si pečlivě prostudujte stavební návod. Při používání barev a lepidel pracujte v dobře větrané místnosti. Lepidla ani barvy nepoužívejte v blízkosti otevřeného ohně. Model není určen malým dětem, mohlo by dojít k požití drobných dílů.

INSTRUCTION SIGNS * INSTR. SYMBOLS * INSTRUKTION SINNBILDEN * SYMBOLES * 記号の説明



OPTIONAL
VOLBA



BEND
OHNOU



OPEN HOLE
VYVRTAT OTVOR



SYMMETRICAL ASSEMBLY
SYMETRICKÁ MONTÁŽ



REMOVE
ODŘÍZNOUT



REVERSE SIDE
OTOČIT



APPLY EDUARD MASK
AND PAINT
POUŽÍT EDUARD MASK
NABARVIT

PARTS



DÍLY



TEILE



PIÈCES



部品

PLASTIC PARTS

C>

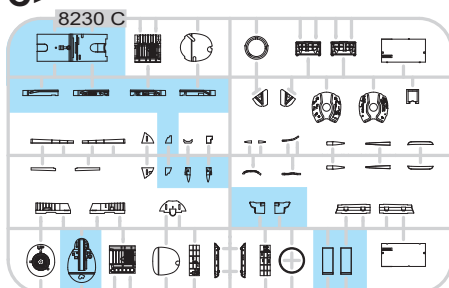

D>

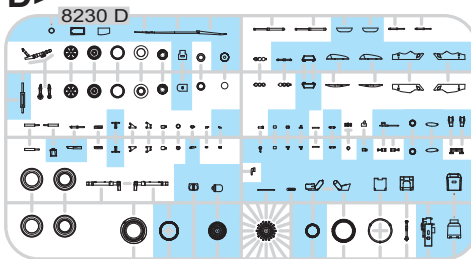

E> 2 pcs.

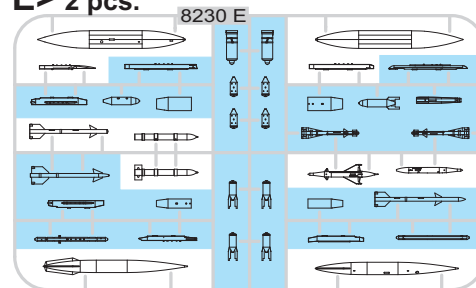

S>

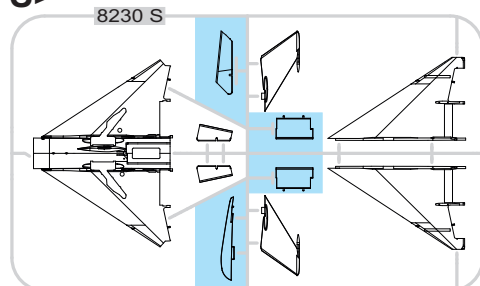

T>

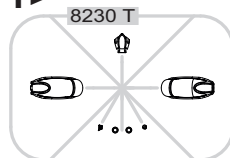

U>

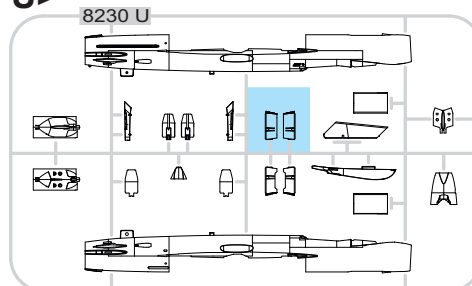

V>

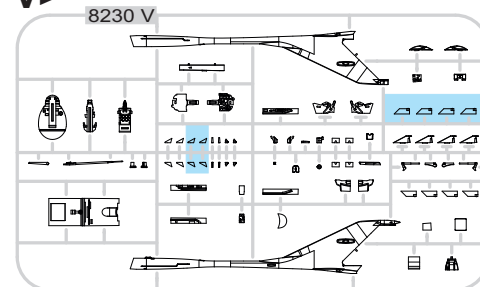

PE - PHOTO ETCHED DETAIL PARTS

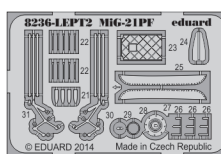
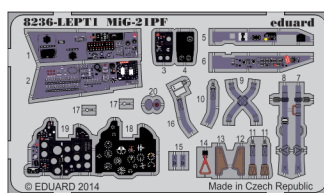
eduard
MASK

-Parts not for use. -Teile werden nicht verwendet. -Pièces à ne pas utiliser. -Tyto díly nepoužívejte při stavbě. - 使用しない部品

COLOURS



BARVY



FARBEN



PEINTURE



色

GSI Creos (GUNZE)		
AQUEOUS	Mr.COLOR	
H 2	C2	BLACK
H 3	C3	RED
H 4	C4	YELLOW
H 5	C5	BLUE
H 11	C62	FLAT WHITE
H 12	C33	FLAT BLACK
H 26	C66	BRIGHT GREEN
H 37	C43	WOOD BROWN
H 47	C41	RED BROWN
H 51	C11	LIGHT GRAY
H 53	C13	NEUTRAL GRAY

AQUEOUS	Mr.COLOR	
H 58	C27	INTERIOR GREEN
H 66	C19	SANDY BROWN
H 67	C115	LIGHT BLUE
H 70	C60	GRAY
H 71	C21	MIDDLE STONE
H 77	C137	TIRE BLACK
H 81	C55	KHAKI
H 84	C42	MAHOGANY
H 90	C47	CLEAR RED
H 94	C138	CLEAR GREEN
H 302	C302	GREEN
H 303	C303	GREEN

AQUEOUS	Mr.COLOR	
H 308	C324	GRAY
H 324	C324	LIGHT GRAY
H 332	C332	LIGHT GRAY
H 417	C117	LIGHT BLUE
H 417	C8	SILVER
Mr.METAL COLOR		
MC213		STAINLESS STEEL
MC214		DARK IRON
MC218		ALUMINIUM
Mr.COLOR SUPER METALLIC		
SM01		SUPER FINE SILVER
SM06		CHROME SILVER

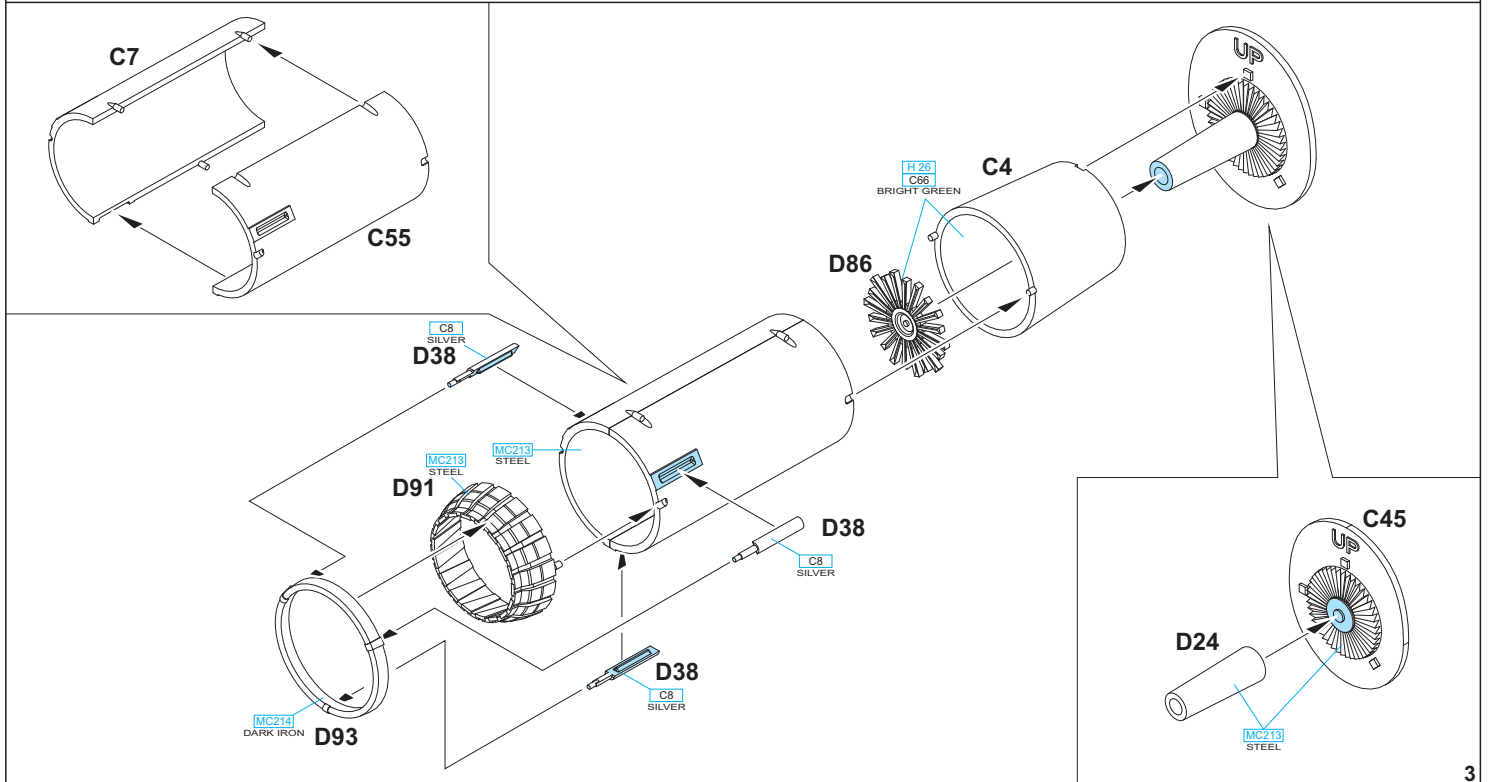
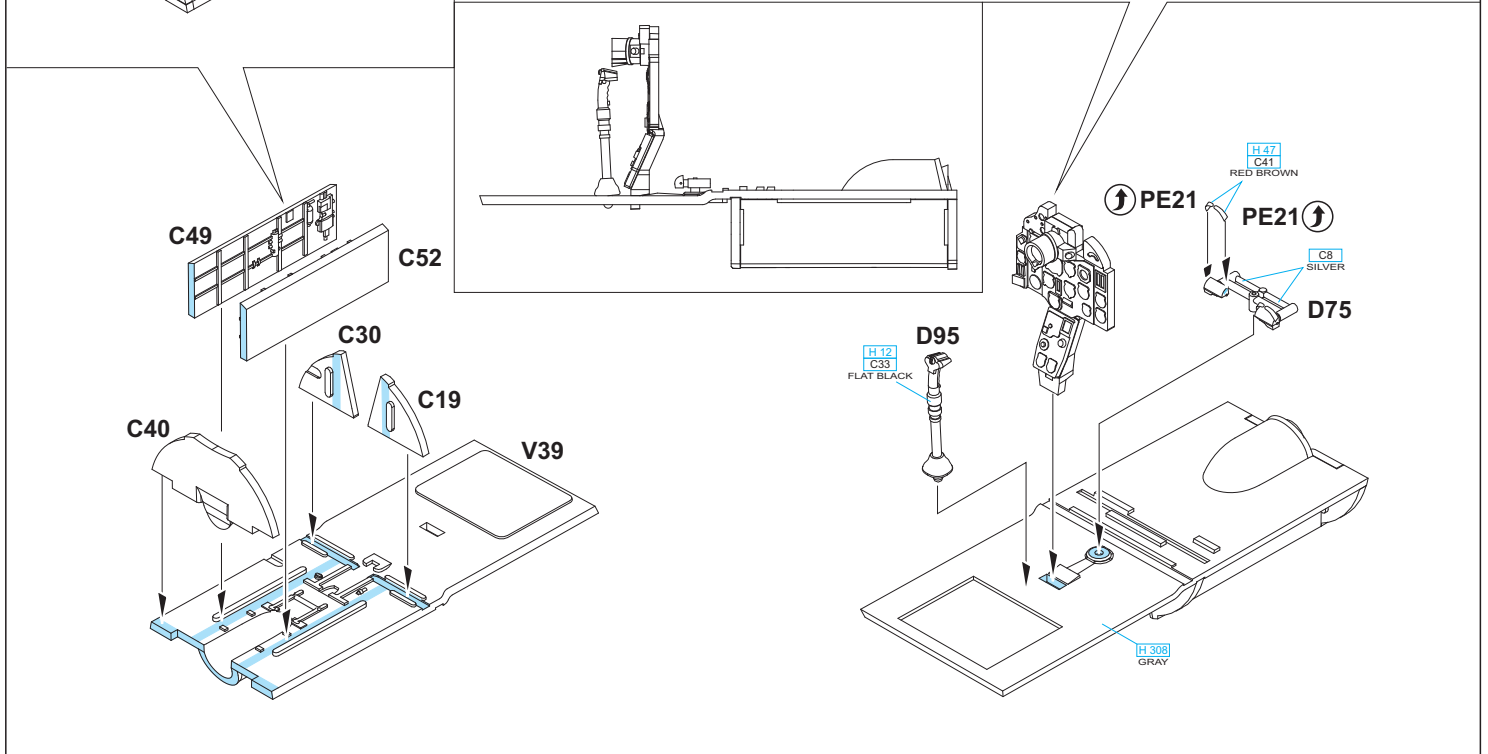
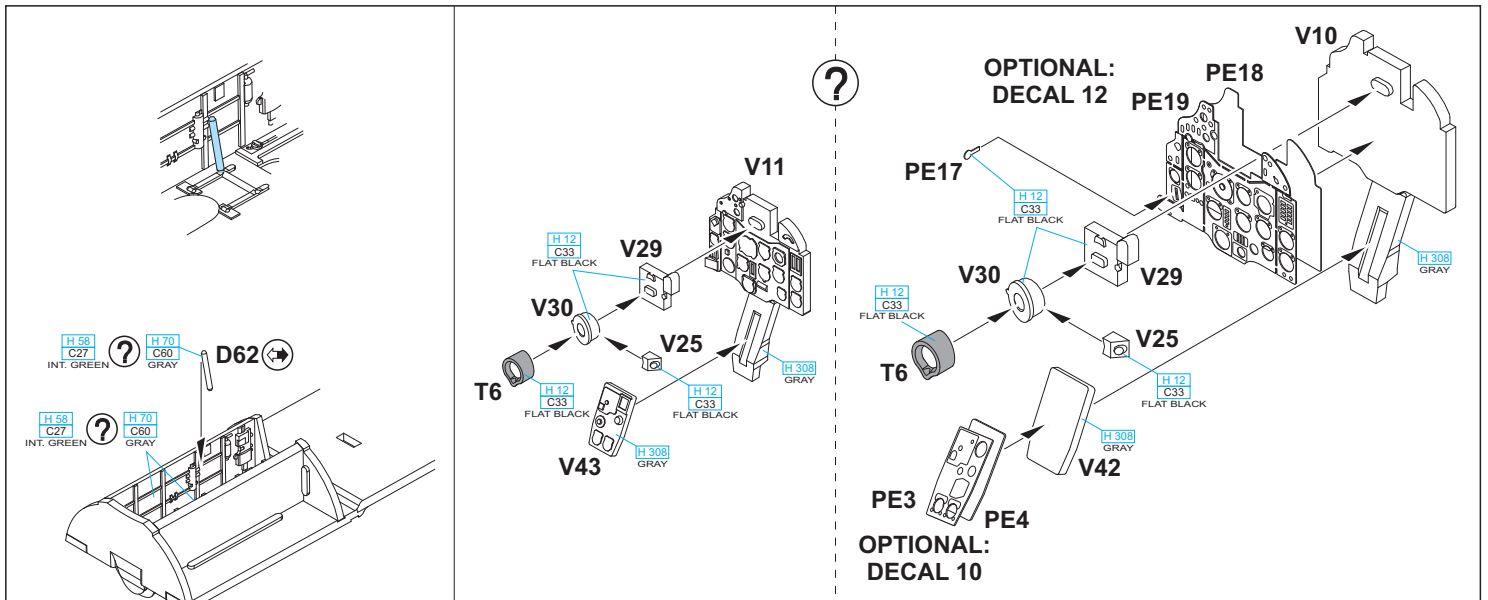

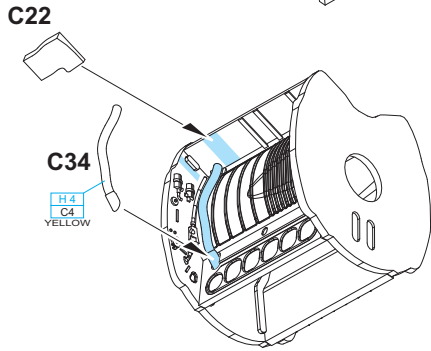
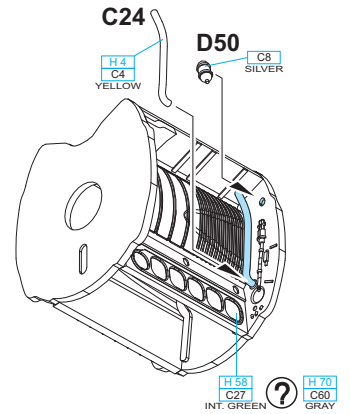
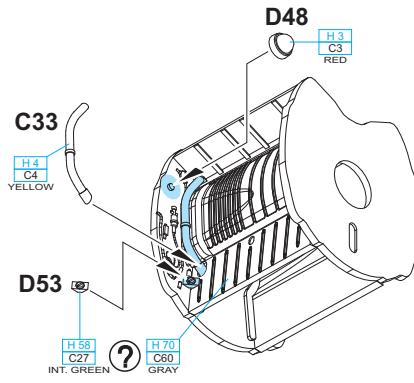
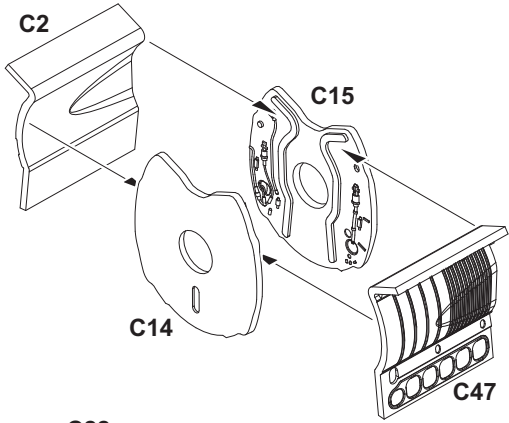

OPTIONAL:
DECAL 22 ↻ PE2

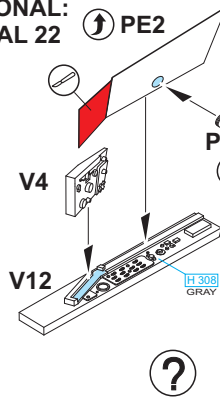

OPTIONAL:
DECAL 21, 22 ↻ PE2

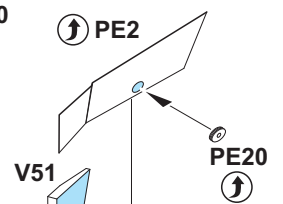

?

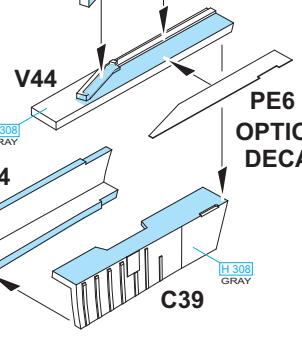

OPTIONAL:
DECAL 11

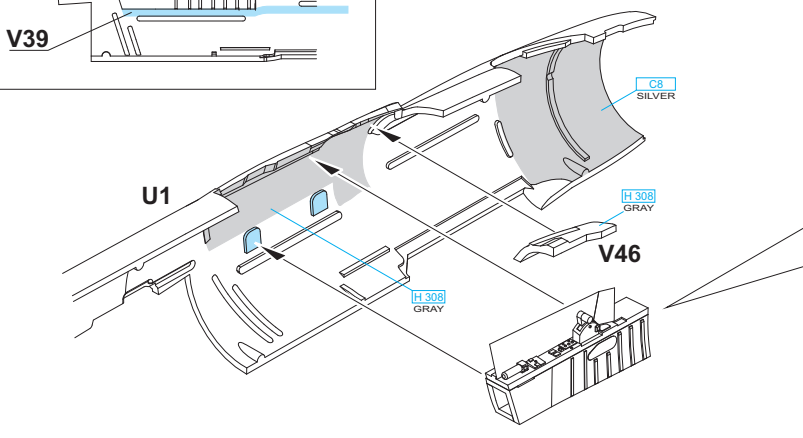
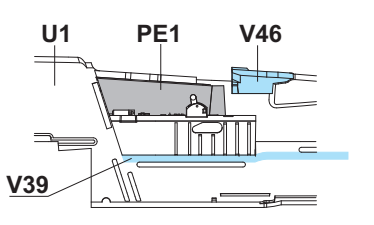
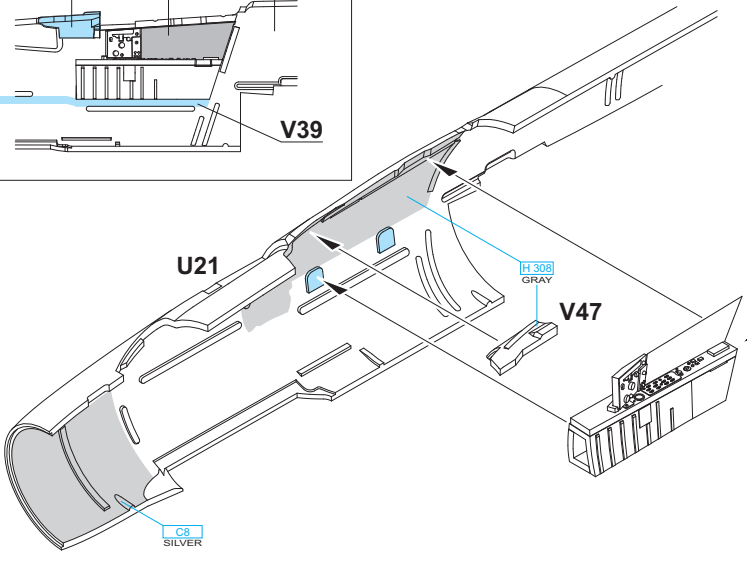
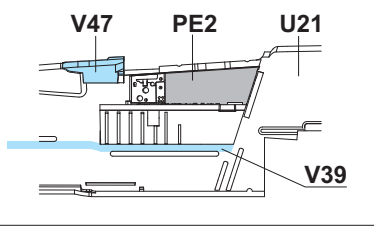

OPTIONAL:
DECAL 20 ↻ PE1

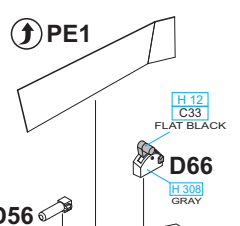
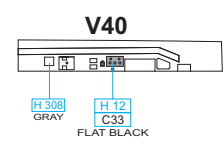

OPTIONAL:
DECAL 9

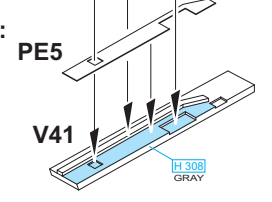

OPTIONAL:
DECAL 20 ↻ PE1

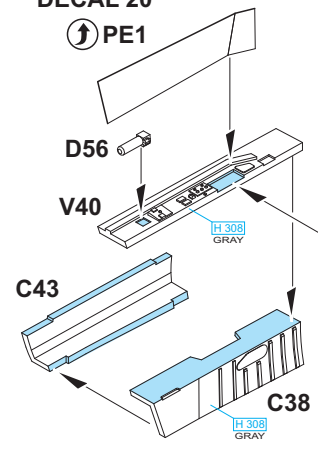

?

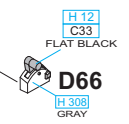

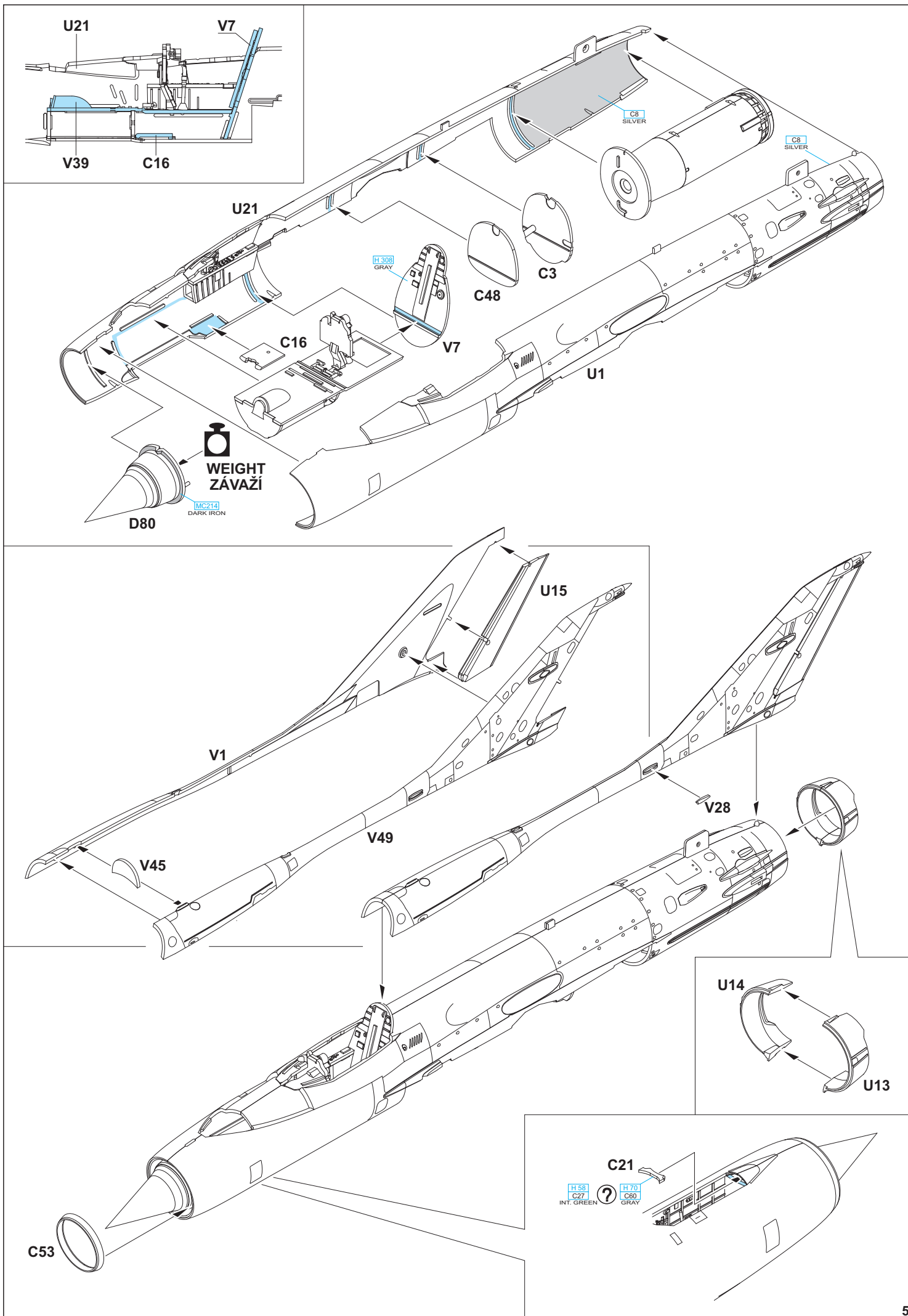

FOR OPEN AIR BRAKES ONLY
JEN PRO OTEVŘENÉ ŠTÍTY

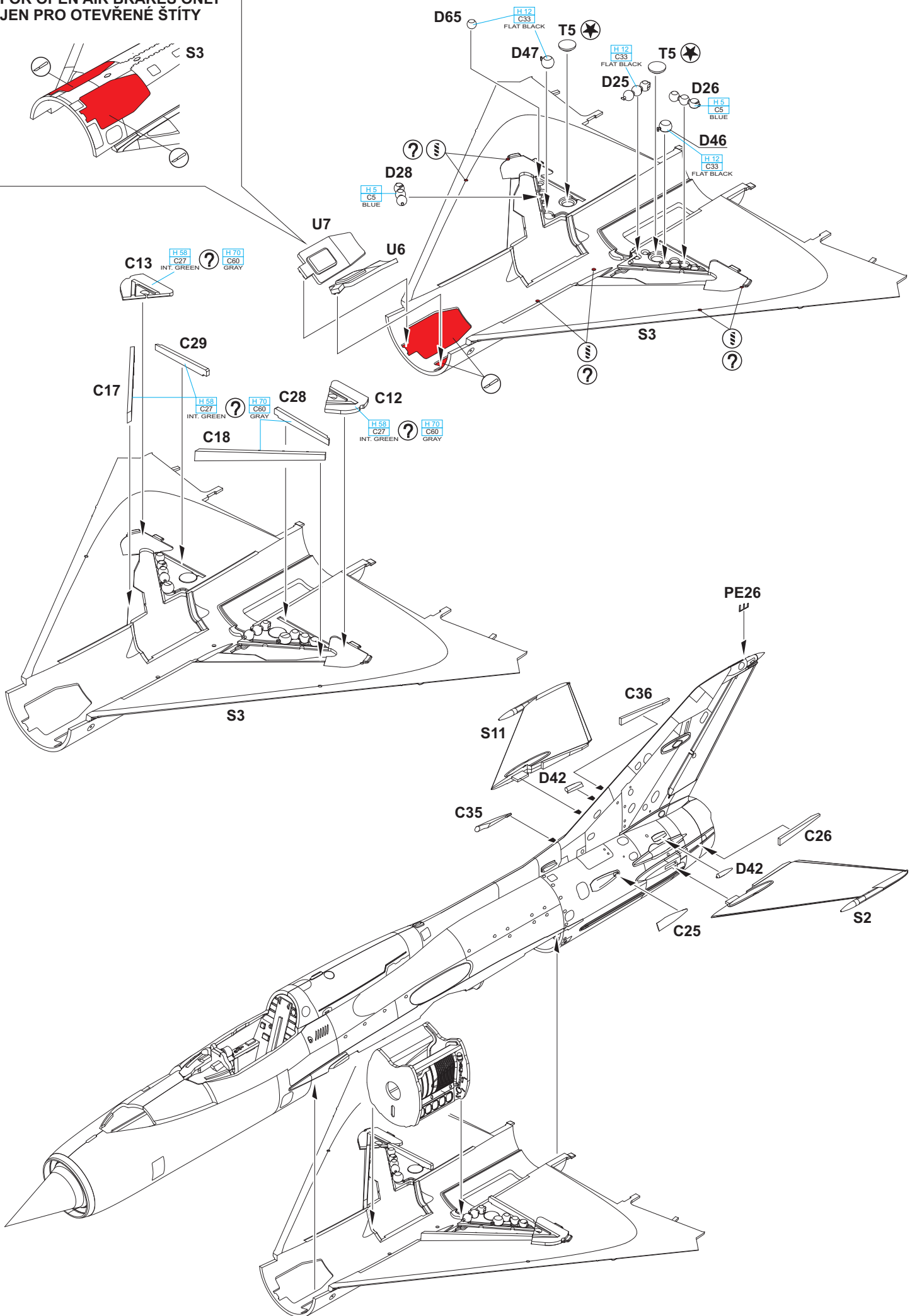
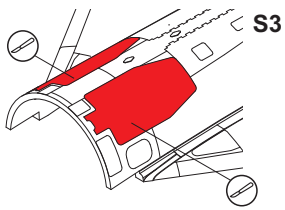

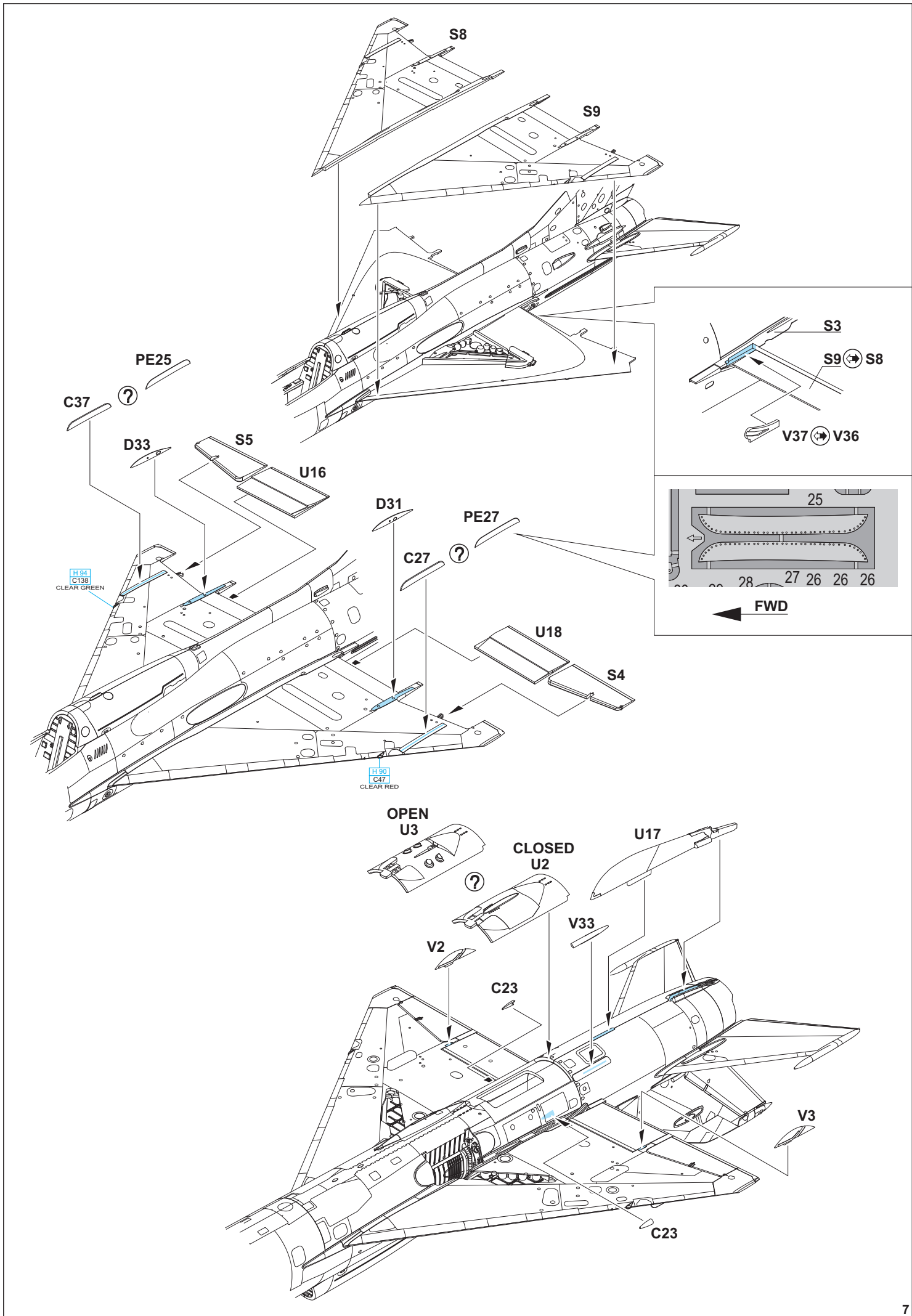

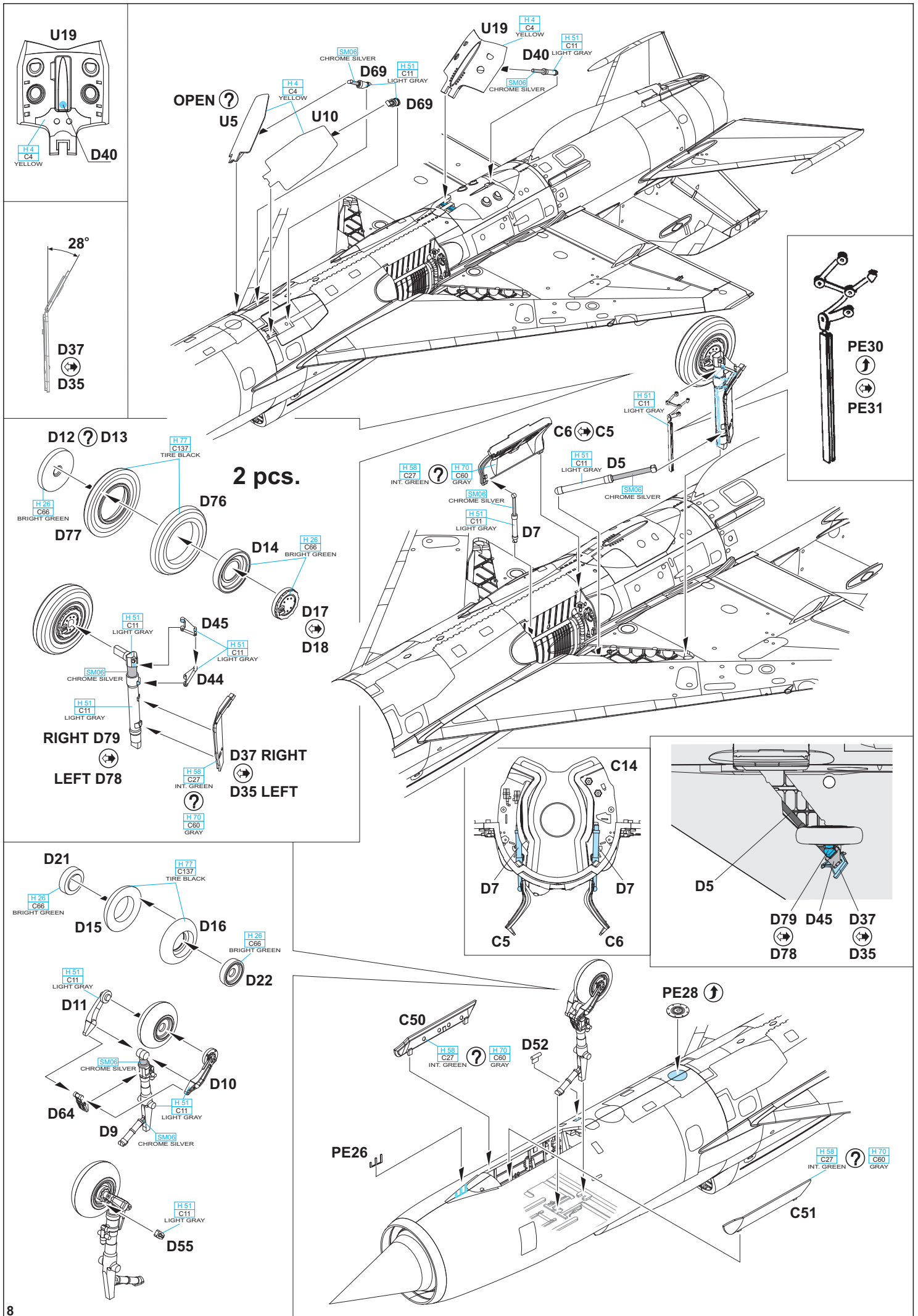

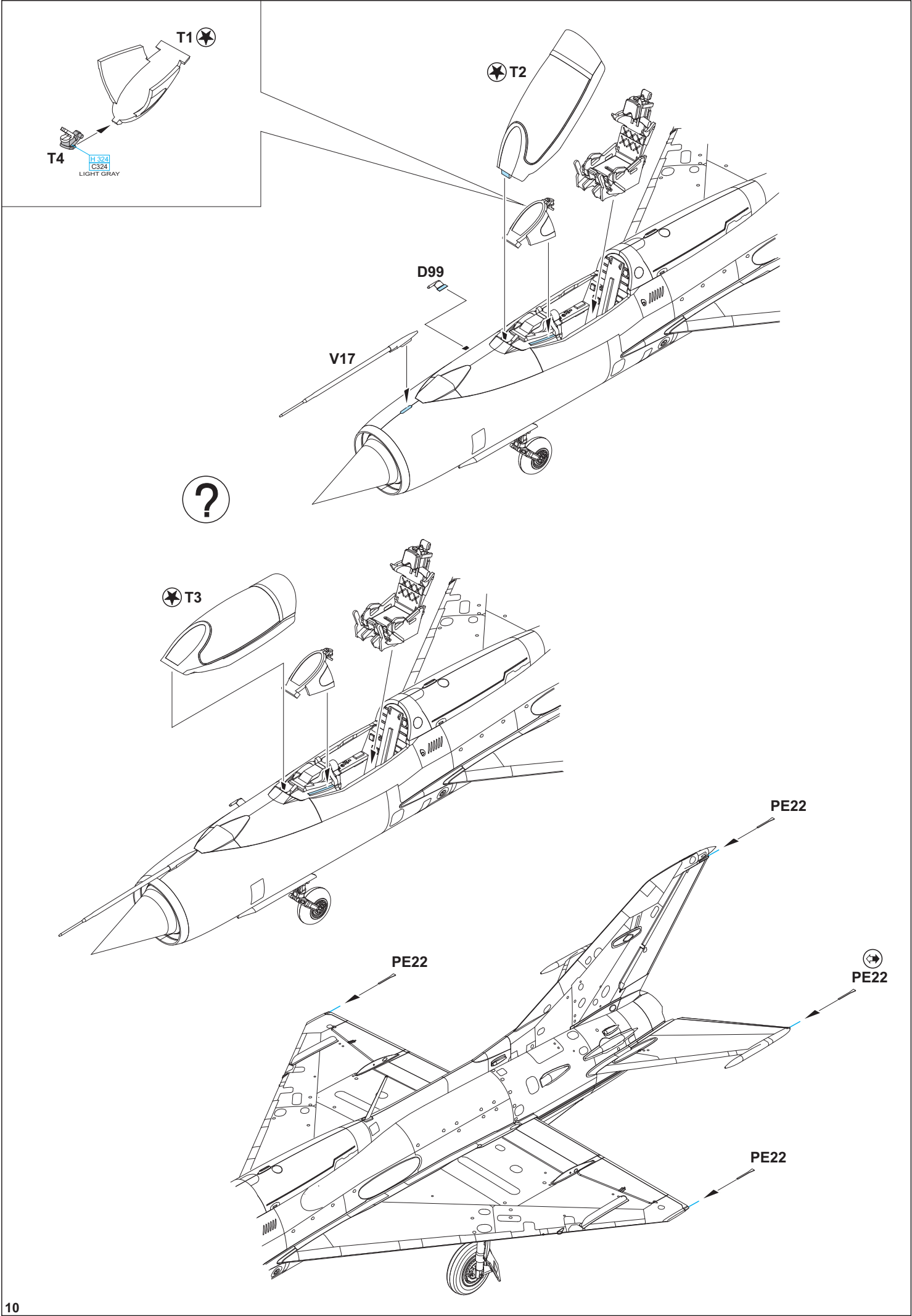

EXTERNAL FUEL TANK 800I
PRÍDAVNÁ NÁDRŽ 800I

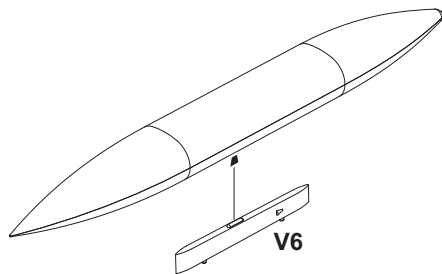
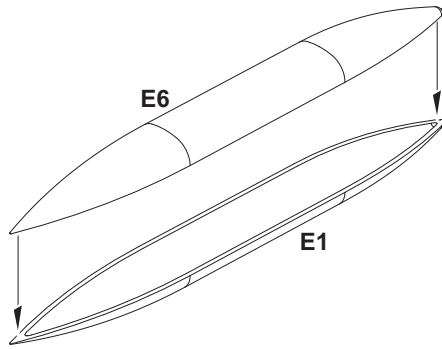

EXTERNAL FUEL TANK 490I
PRÍDAVNÁ NÁDRŽ 490I

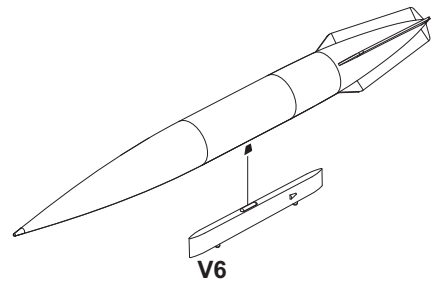
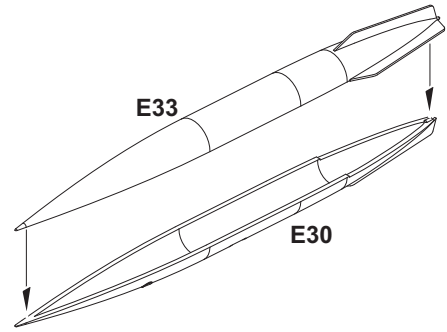

RS-2US
2 pcs.

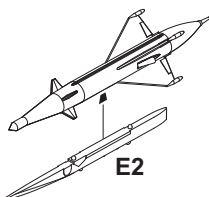
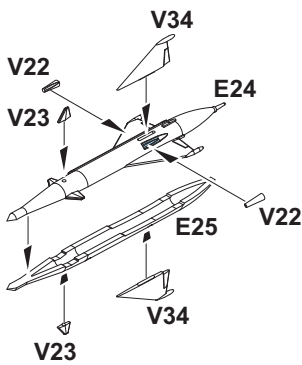

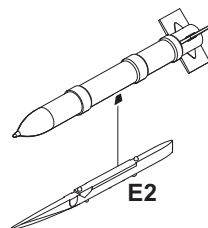
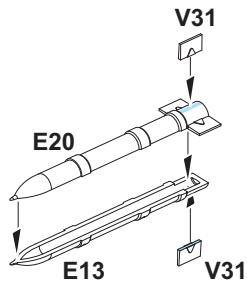

S-24
2 pcs.



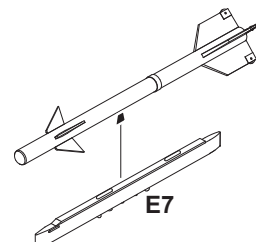
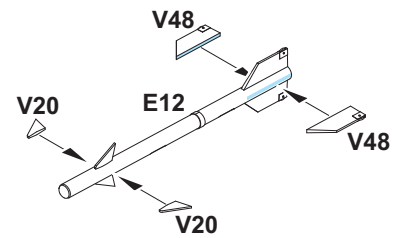

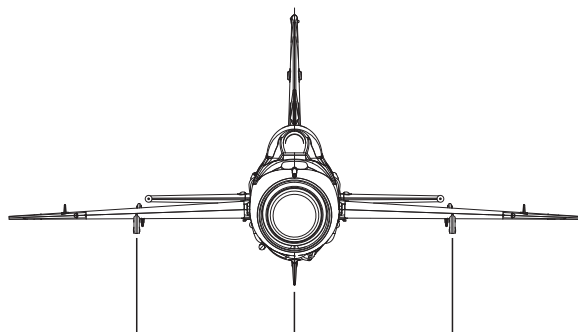
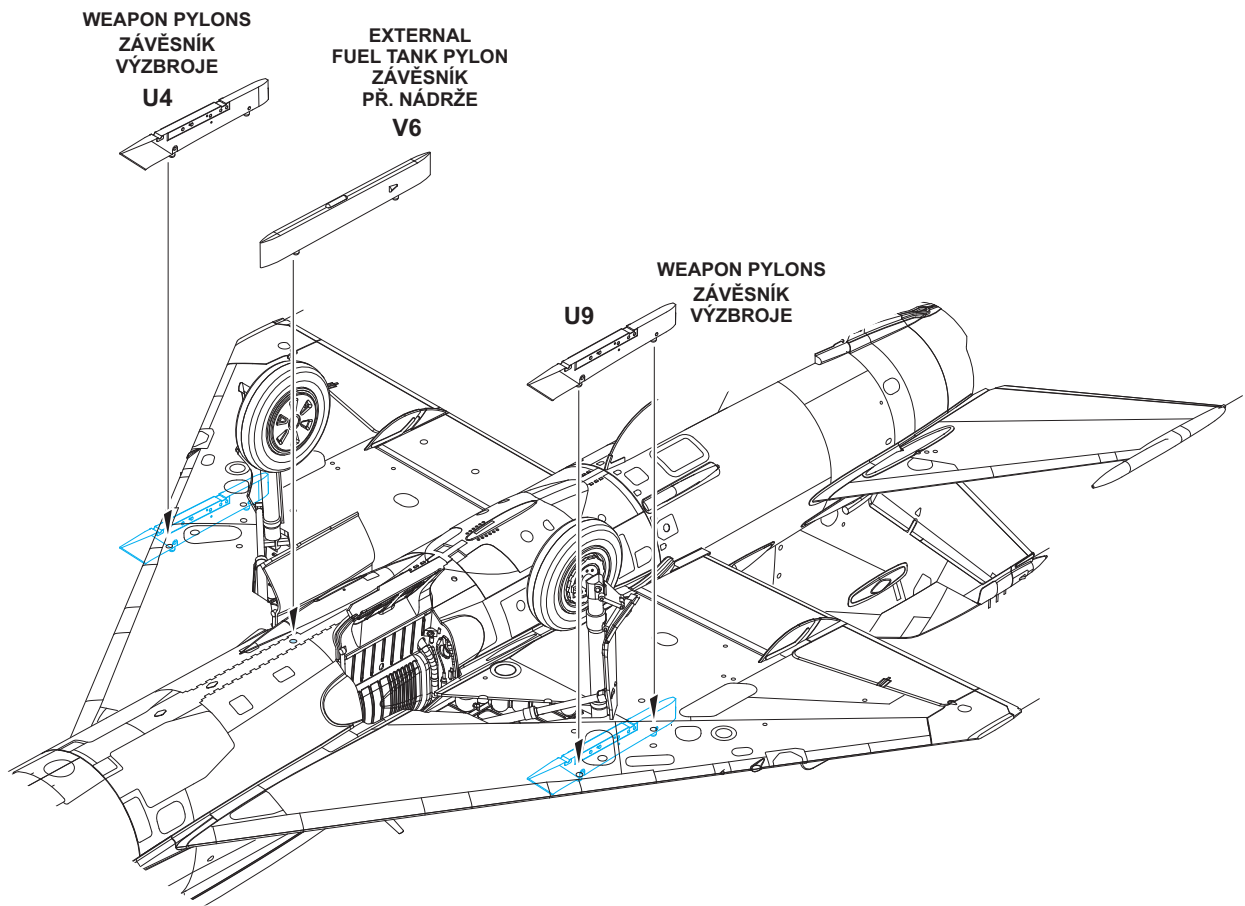



R-3S
2 pcs.

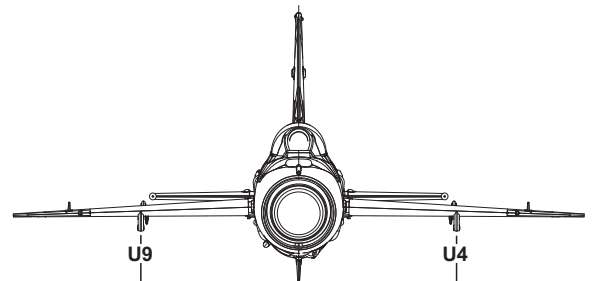



EXTERNAL FUEL TANK 800I	I V6 
EXTERNAL FUEL TANK 490I	I V6 



S-24	I E2 	I E2 
RS-2US	I E2 	I E2 
R-3S	I E7 	I E7 

TO CHOOSE WEAPON AND EXTERNAL FUEL TANK OPTION PLEASE FOLLOW YOUR REFERENCE.

PRO VOLBU VÝZBROJE A PŘÍDAVNÝCH NÁDRŽÍ SE DRŽTE DOKUMENTACE KONKRÉTNÍHO STROJE.

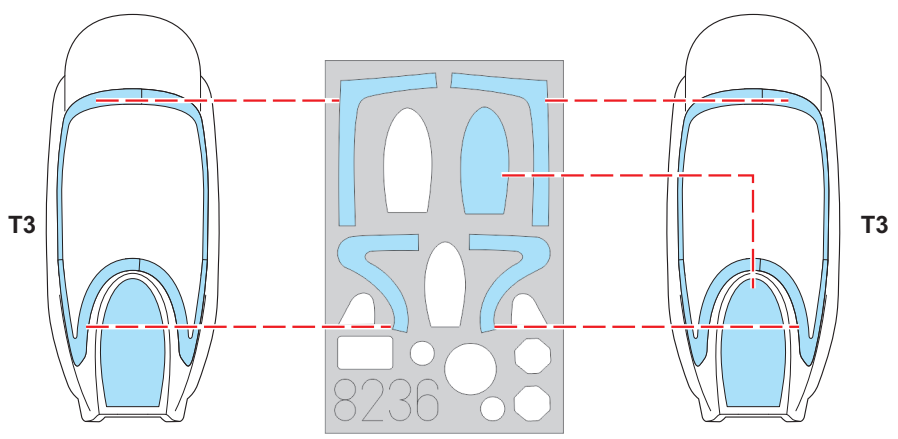
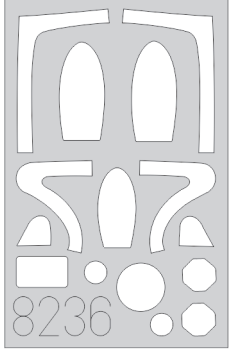

?

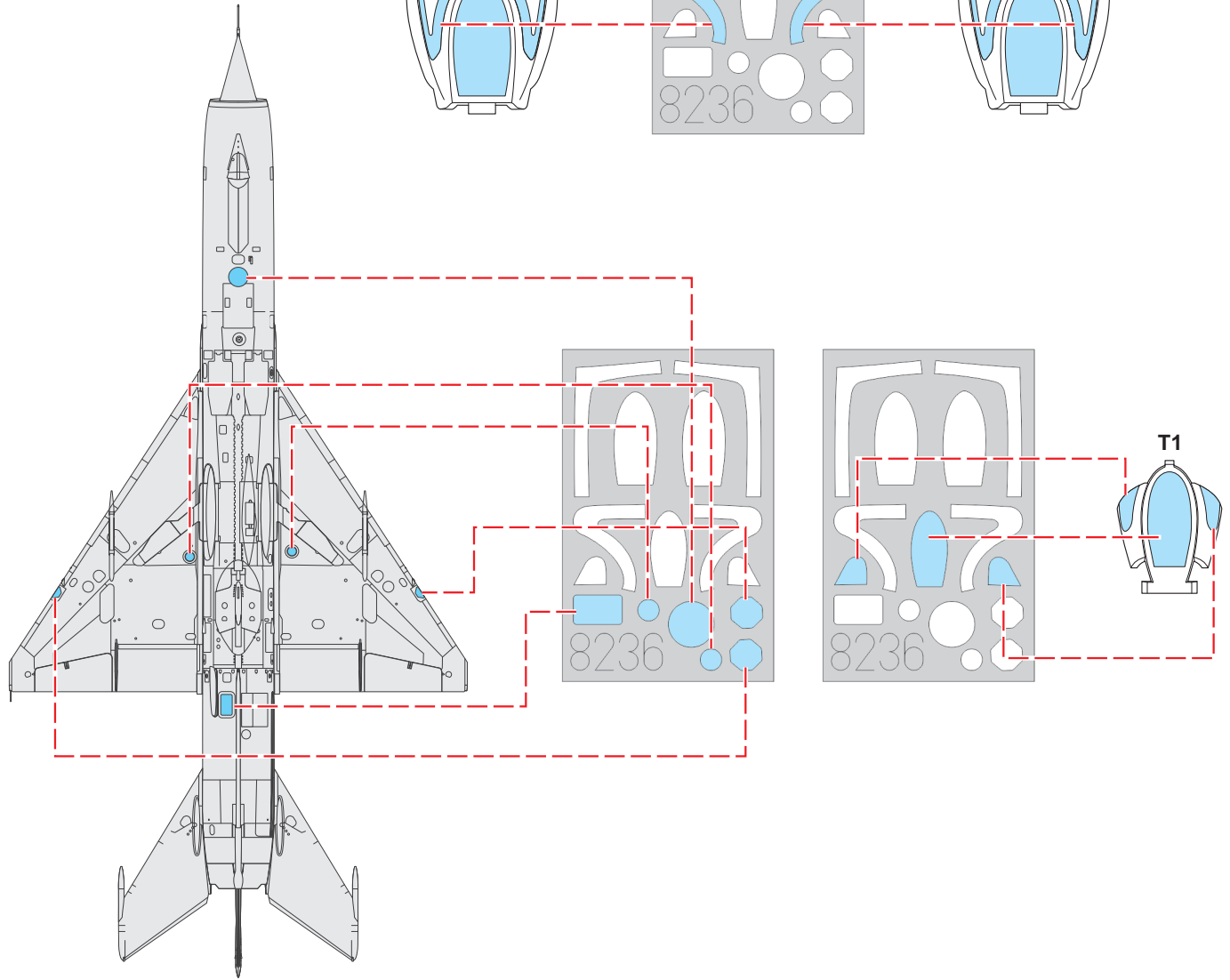
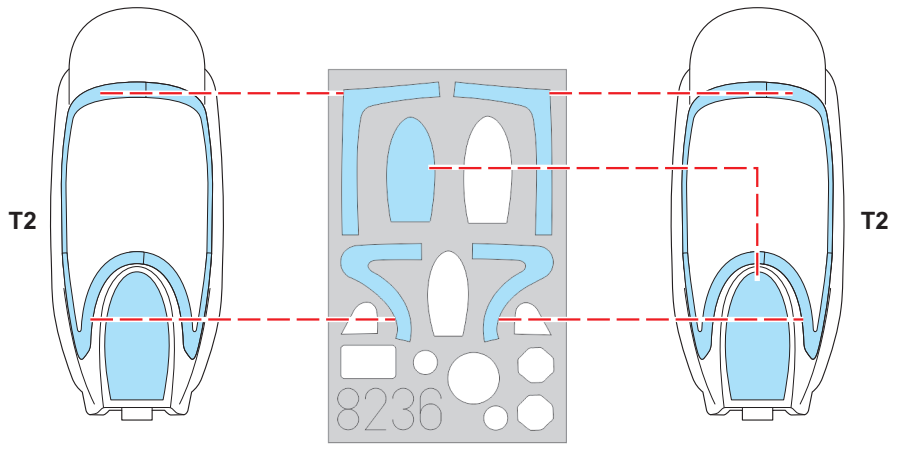

A 921st Fighter Regiment, Vietnam, Late 60s / Early 70s

This aircraft was delivered to Vietnam in 1966 and served as a part of 921st Fighter Regiment. Thirteen red stars painted on the nose depict victories gained by the pilots who flew this aircraft. One of them was Nguyen Van Coc, the most successful Vietnamese fighter ace with nine confirmed kills to his credit. He downed F-4B BuNo. 151485 on May 7, 1968 while at the controls of this particular MiG. 'Red 4326' is currently displayed in Air Force museum in Hanoi.

Tento stroj byl do Vietnamu dodán v roce 1966. Létal v rámci 921. stíhacího leteckého pluku. Třináct červených hvězdiček na přídí symbolizuje sestřely dosažené s „červenou 4326“. Jedním z pilotů, kteří se zasloužili o namalování těchto symbolů vítězství, byl i Nguyen Van Coc, nejúspěšnější vietnamské stíhací eso s devíti potvrzenými sestřely. V kokpitu tohoto letounu měl 7. května 1968 sestřelit F-4B Phantom BuNo. 151485. V současné době je stroj součástí expozice hanojského leteckého muzea.



STEEL	MC213	ALUMINIUM	SM01
DARK IRON	MC214	GREEN	H26 66
BLACK	H2 2	RED	H3 3
DARK BROWN	H84 42	SANDY BROWN	H66 19

B Serial Number 761008, Jagdfliegergeschwader 2, German Democratic Republic, Trollehagen Air Base, Late 80s

East German air force received this MiG on May 1, 1965. The aircraft was flown by JG8, JG9 and finally by JG2. The aircraft was put out of service in 1988 and scrapped shortly afterwards despite a plan to sell it to Iran. This MiG became well known thanks to a propaganda movie. The fuselage number was changed to 'Red 1851' for filming. The Q-badge painted on the left side of the nose indicated that the ground personnel responsible for this aircraft were recognized for the high quality of their work.

Letoun byl převzat východoněmeckou stranu 1. května 1965. Postupně sloužil u JG8, JG9 a nakonec u JG2. Z výzbroje byl vyřazen v roce 1988 a později sešrotován. Z plánovaného prodeje do Iránu tak sešlo. Letoun je známý díky letovým propagačním záběrům. Během pořízování těchto snímků měl pozměněné trupové číslo a vystupoval jako „červený 1851“. Na levé straně přídě je namalován znak udělovaný za kvalitní práci pozemního personálu při údržbě letounu.

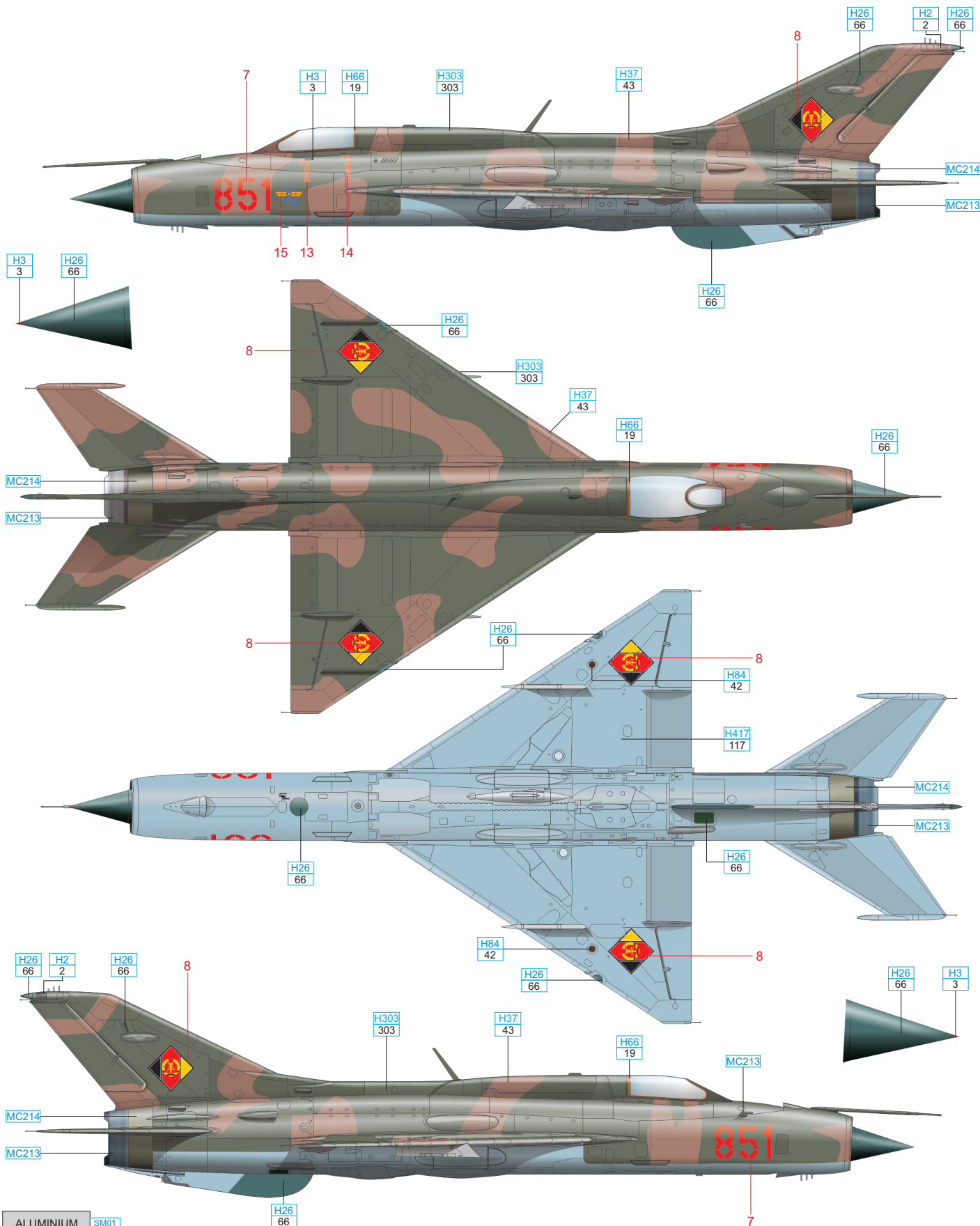

ALUMINIUM	SM01									
STEEL	MC213	GRAY	H417 117	SANDY BROWN	H66 19					
DARK IRON	MC214	GREEN	H26 66	GREEN	H303 303	BROWN	H37 43	RED	H3 3	
									BLACK	H2 2

C Soviet Air Force, Ceske Budejovice Air Base, Czechoslovakia, late August, 1968

On August 21, 1968, Warsaw Pact armed forces led by the Soviet Union began to occupy Czechoslovakia. This act, coded Operation 'Danube', led to the Soviet occupation of Czechoslovakia lasting over twenty years. The MiG-21PF 'Red 40' participated in the invasion of Czechoslovakia in August, 1968. Two red bands on the tail marked aircraft that were used during Operation Danube.

Dne 21. srpna 1968 začala pod krycím názvem operace Dunaj invaze vojsk Varšavské smlouvy do Československa. Celá akce probíhala pod taktovkou Sovětského svazu a výsledkem byla více než dvacetiletá okupace sovětskými vojsky. Součástí invazních sil byl také tento MiG-21PF. Krátce po 21. srpnu se nacházel na letišti v Českých Budějovicích. Dvěma červenými pruhy okolo zádě byly označeny letouny účastníci se invaze.

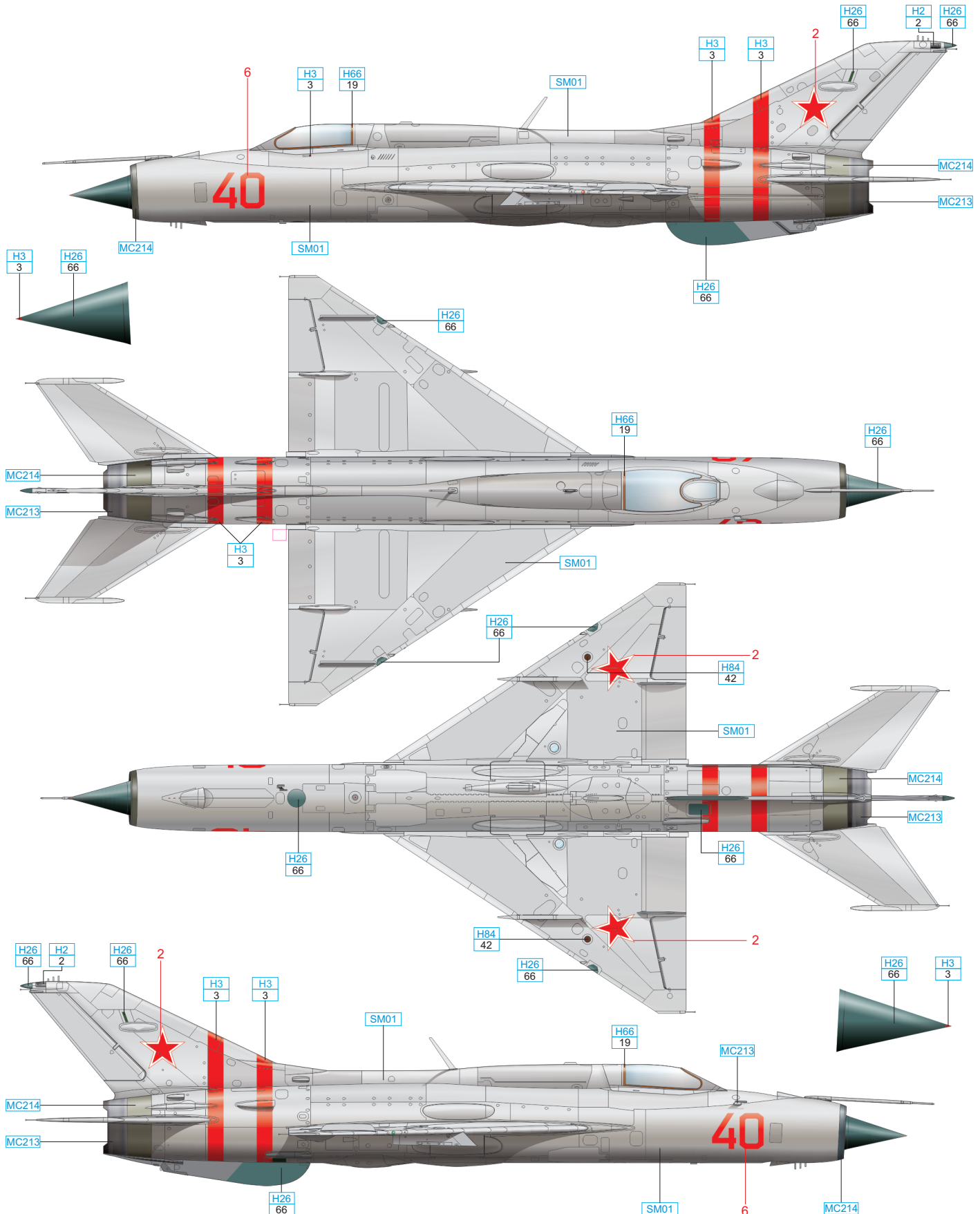

STEEL	MC213	ALUMINIUM	SM01
DARK IRON	MC214	GREEN	H26 66
		BLACK	H2 2
		RED	H3 3
		DARK BROWN	H84 42
		SANDY BROWN	H66 19

D 702nd UAP, Chernigov Air Base, Soviet Union, 1980s

One of the school aviation regiments that flew from air bases located in the Ukraine was 702th UAP. This aircraft was photographed at Chernigov Air Base in the eighties, although the regiment was based in Umani. 702nd UAP was a part of Chernigov Higher Military Aviation School of Pilots along with three more school regiments. This color profile is based on a black and white photo.

Jedním ze školních leteckých pluků, které v dobách Sovětského svazu působily na území dnešní Ukrajiny, je také 702. UAP. Tento stroj byl v 80. letech vyfotografován na letišti Černigov, ačkoliv pluk sídlil v Umani. 702. UAP byl společně s dalšími třemi školními pluky součástí Černigovského vyššího leteckého pilotního učiliště. Rekonstrukce kamuflážního schématu byla provedena na základě černobílého snímku.

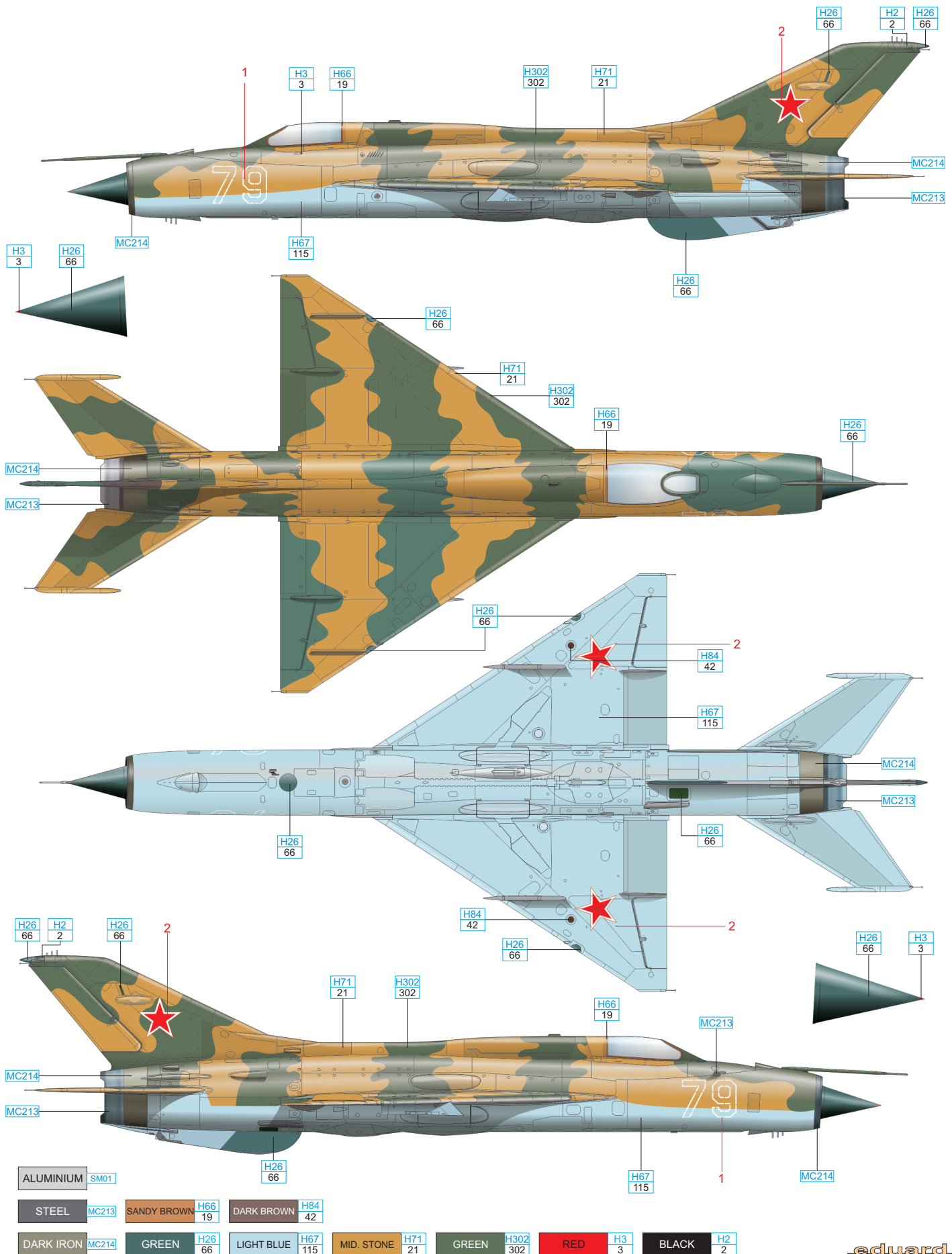

E 1st Fighter Regiment, Polish Air Force, Minsk Mazowiecki Air Base, 1980s

This MiG-21PF is one of the aircraft displayed in the Polish Army Museum in Warsaw. It was accepted by the Polish Air Force during early January, 1965, and served with various fighter regiments. The last military unit that flew 'Red 0615' was the 1st Fighter Regiment (1. plm). The aircraft is listed here from 1971 to 1974 and from March 1980 till the end of August 1988. The unit badge depicting a mermaid is painted on both sides of the nose.

Jedním z exponátů Muzea vojska polského je tento MiG-21PF. Stroj byl do Polska dodán na počátku ledna 1965 a postupně sloužil u několika stíhacích pluků. Posledním působištěm se stal 1. plm, kde působil od v letech 1971 až 1974 a pak také od března 1980 do konce srpna 1988. Znak tohoto útvaru, zobrazující mořskou pannu, je namalován na přední stroje.

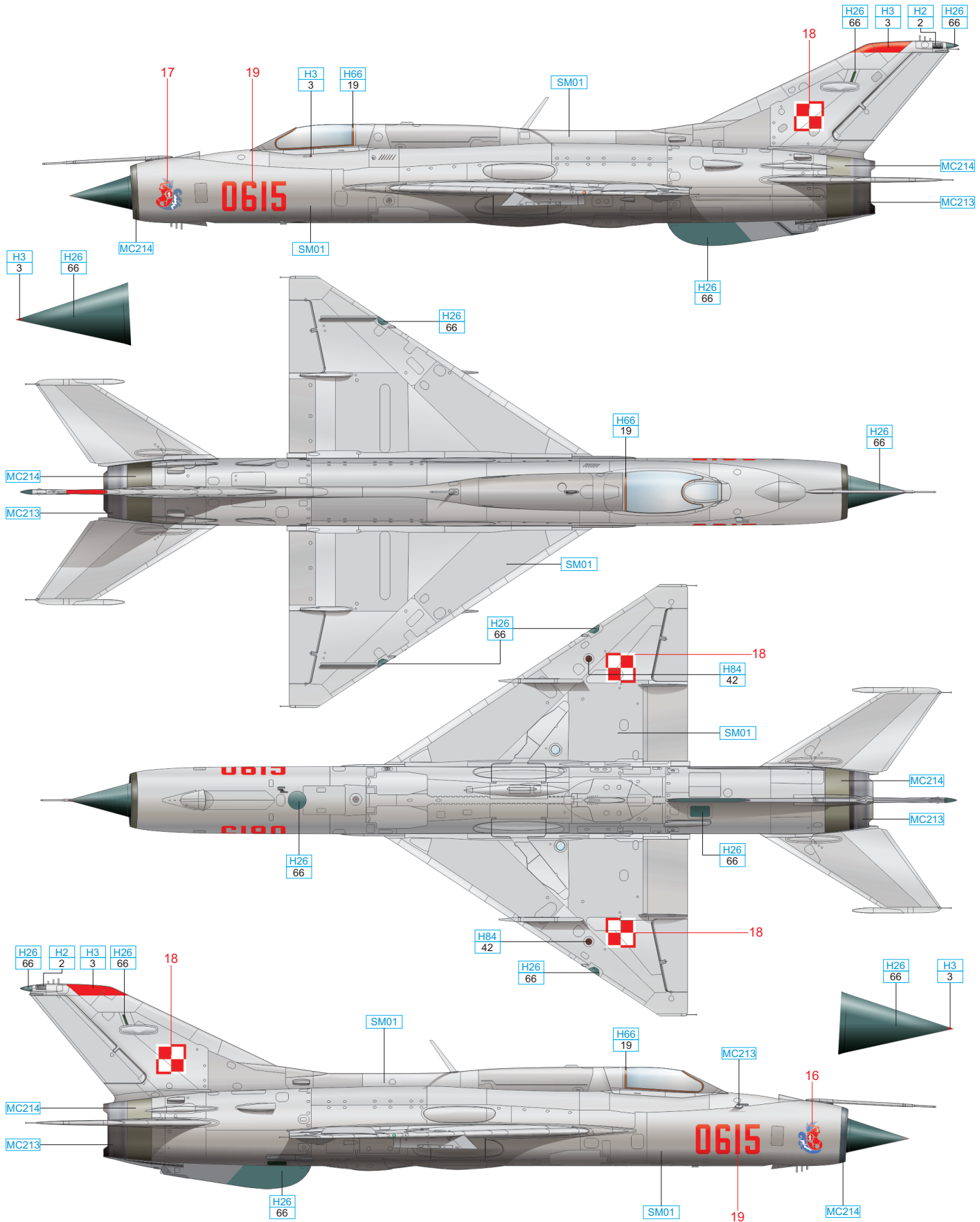

STEEL	MC213	ALUMINIUM	SM01
DARK IRON	MC214	GREEN	H26 66
BLACK	H2 2	RED	H3 3
DARK BROWN	H84 42	SANDY BROWN	H66 19

LEVÝ PYLON
LEFT PYLON

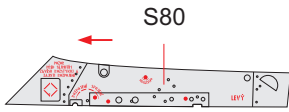

PRAVÝ PYLON
RIGHT PYLON

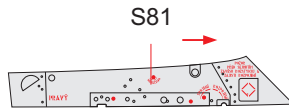

LEVÉ APU-7
LEFT APU-7

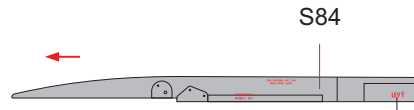

PRAVÉ APU-7
RIGHT APU-7

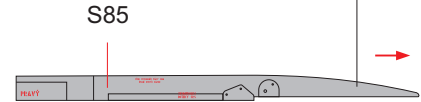

PODTRUPOVÝ PYLON
FUSELAGE PYLON

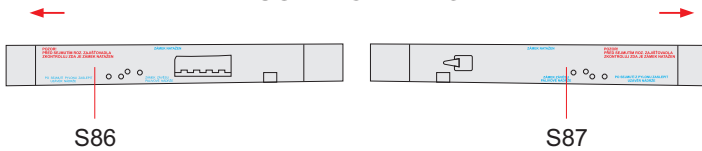

LEVÉ APU-13
LEFT APU-13

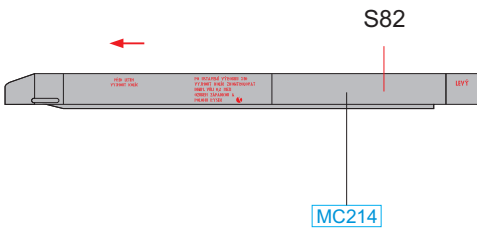

PRAVÉ APU-13
RIGHT APU-13

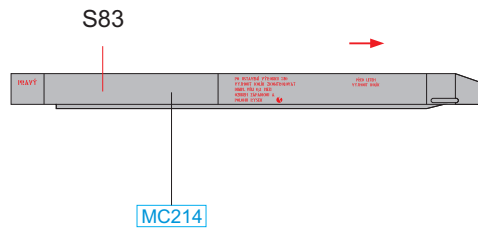

RS-2US

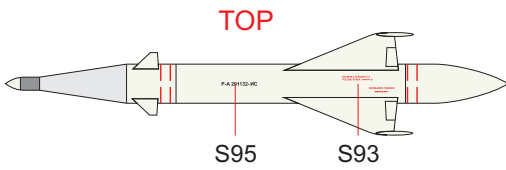

S-24

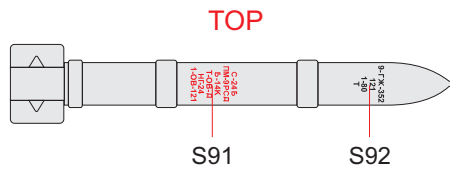

R-3S

