

Bf 109E-4

eduard

1/48 Scale Plastic Model Kit

ProfiPACK
edition



item No. 8263

No other aircraft is so intimately connected with rise and fall of the German Luftwaffe during the WWII like the Messerschmitt Bf 109. Its early variants gave the Luftwaffe an upper hand over the opponents.

The evolution of this aircraft outlived the era in which it was conceptualized. The Bf 109s bore the brunt of Luftwaffe duties from the opening battles of Nazi Germany through to her final downfall.

The history of the Bf 109 begins during 1934-35, when the Reich Ministry of Aviation issued a requirement for the development of a monoplane single-engined fighter. Proposals were submitted by Arado, Heinkel, Focke-Wulf and Bayerische Flugzeugwerke. The team of designers of the last-mentioned company was led by its technical director Willy Messerschmitt, who's goal was to conceive of an aircraft with the best possible performance for the specified weight and size. Over the subsequent months, several prototypes were built. The aircraft was rather tiny and compared to the prevailing trends of the time, full of progressive features such as low wing design, retractable landing gear, wing with a thin airfoil, wing slats, landing flaps, weapons firing through the propeller hub, and so on. At its conception, the Bf 109 was a very promising asset despite some powerplant troubles, which were solved by the introduction of the DB 601. This engine, together with its extrapolated development DB 605, is umbilically connected to the success of the Bf 109. These two-row, twelve-cylinder inverted V engines powered several tenths of thousands of 109s in over 25 versions and variants.

From Spanish War to the Reich Defence

The first combat use of Bf 109 occurred during Spanish Civil War, where three developmental Bf 109s were deployed in December 1936. The main reason of revealing the modern fighter to the world was to validate the aircraft's abilities in modern aerial combat. Shortly thereafter, production Bf 109B-1s began to reach 2.J/88, the Legion Condor. The desire of Germany to demonstrate its aerial prowess to potential foes was advanced further in international sport meets. The triumphs attained in Zurich in the summer of 1937 were complemented several months later by grabbing the speed record of 610.95 kph. In very short order, the progressive developments represented by the C, D and E versions appeared. The delivery of Bf 109s to combat units did not sustain the rate that was desired by military brass. Even by August 1938 the Bf 109 accounted for less than half of the 643 front line fighters in service. The later months saw an increase in these rates and by the time of the invasion of Poland the Luftwaffe possessed the best fighter produced in the continental Europe. With both a qualitative and quantitative advantage, the Luftwaffe entered the Polish campaign, the first defense of the Fatherland, Blitzkrieg against the West, and the Battle for France. After this period of continual success, the Luftwaffe embarked on the attacks on Great Britain in the summer months of 1940. Here, the first weakness of the Bf 109 emerged: The inability to carry drop tanks that would have enabled the type to effectively escort bombers to England. This was one of the factors responsible for the defeat of the Luftwaffe in the Battle of Britain. Experiences gained in 1940 led to the development of the F (Friedrich) version prior to the spring of 1941 followed by late production variants of Bf 109G (Gustav) and K (Kurfürst).

Emil emerges

The Bf 109E series represents a turning point in the development of the Bf 109. It saw the replacement of the Jumo 210 engine with the more powerful, more reliable and also larger and heavier unit Daimler-Benz DB 601 driving the VDM (Vereinigte Deutsche Metallwerke) three-bladed propeller.

The larger and more powerful engine also needed a larger coolant radiator. Instead of a large "chin" on the nose, which would have significantly increased aerodynamic drag, cooling was moved to flat radiators on the bottom of the wing. This relocation also helped to balance the increased weight of the engine and propeller, but required the entire wing to be redesigned. To verify the design changes, V14 and V15 prototypes were built, differing in armament. The former had a pair of 7.92 mm MG 17 machine guns supplemented by two 20 mm wing-mounted guns. The V15 prototype had only two machine guns.

Production of the first production version of the "Emil", the E-1 version, began in early 1939 and the extra 298 hp (223 kW) compared to previous Jumo 210 also provided a corresponding increase in flight performance despite the 400 lb (180 kg) weight increase.

The E-1 version was armed with four MG 17 machine guns, and further development concentrated mainly on armament. The E-2 received an MG FF cannon mounted in between the engine cylinder blocks, firing through the center of the propeller instead of two wing machine guns. Although this configuration eventually became standard on the later G and K versions, it was not successful with the E-2. Nevertheless, the "Motorkanone" was retained in the E-3 version, which also had two MG FF guns in the wing. However, due to vibrations caused by firing, the "Motorkanone" was often removed by frontline units. The firing power of two machine guns and two cannons was still more than satisfactory.

The kit: Bf 109E-4

At the beginning of the Battle of Britain, the Bf 109E-4 began to replace the E-3 version. The first aircraft appeared in July 1940 and quickly replaced their predecessors. Many E-3s were also converted to E-4 standard. The differences between the two versions were relatively minor. The Bf 109E-4 in particular received improved MG FF/M wing guns with higher rate of fire and also with the ability to fire a new type of explosive ammunition. In addition, the armor protection behind the pilot's head was improved and the cockpit canopy was revised. To make the production easier, the canopy with rounded corners was replaced by a "boxy" type with straight windows attached to the welded frame. The new canopy also improved the pilot's view from the cockpit. Some Bf 109E-4s and later versions of "Emil" received the improved DB 601N high-altitude engine with 1,159 hp (864 kW). They were designated E-4/N. Similar to the E-1 version, a fighter-bomber (JaBo) version of E-4 was also produced, designated either E-4/B (with the DB 601A engine) or E-4/BN (with the DB 601N). It had provision for one 250 kg bomb or four 50 kg bombs. A total of 561 Bf 109E-4s were produced.

ATTENTION



UPOZORNĚNÍ



ACHTUNG



ATTENTION



注意



Carefully read instruction sheet before assembling. When you use glue or paint, do not use near open flame and use in well ventilated room. Keep out of reach of small children. Children must not be allowed to suck any part, or pull vinyl bag over the head.



Před započítím stavby si pečlivě prostudujte stavební návod. Při používání barev a lepidla pracujte v dobře větrané místnosti. Lepidla ani barvy nepoužívejte v blízkosti otevřeného ohně. Model není určen malým dětem, mohlo by dojít k požití drobných dílů.

INSTRUCTION SIGNS * INSTR. SYMBOLS * INSTRUKTION SINNBILDEN * SYMBOLES * 記号の説明

OPTIONAL
VOLBABEND
OHNOUTSAND
BROUSITOPEN HOLE
VYVRTAT OTVORSYMETRICAL ASSEMBLY
SYMETRICKÁ MONTÁŽREMOVE
ODŘÍZNOUTREVERSE SIDE
OTOČITAPPLY EDUARD MASK
AND PAINT
POUŽIT EDUARD MASK
NABARVIT

PARTS



DÍLY



TEILE



PIÈCES



部品

PLASTIC PARTS

A>

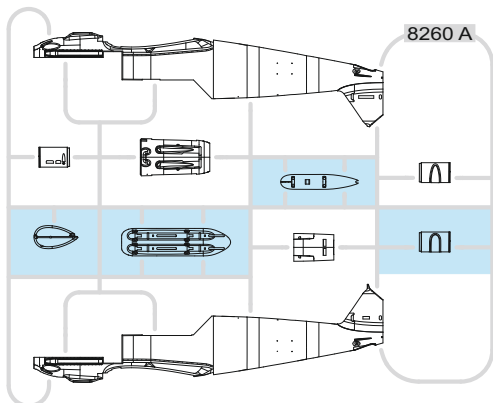

C>

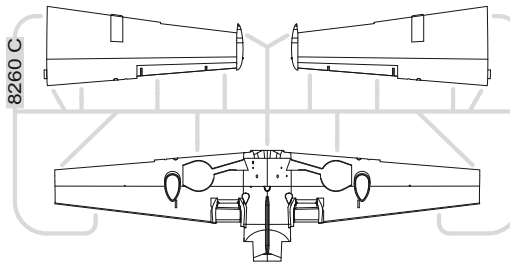

G>

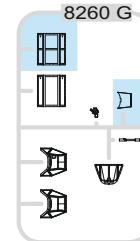

D>

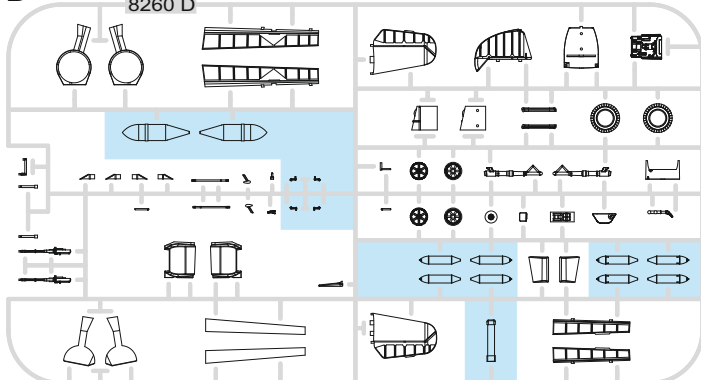

E>

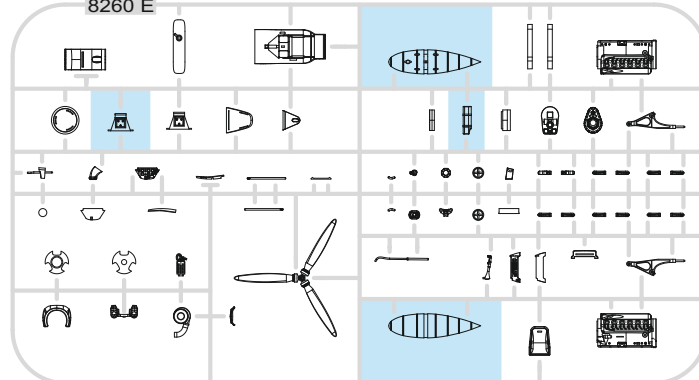
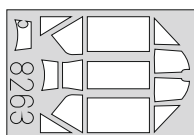
eduard
MASK

PE - PHOTO ETCHED DETAIL PARTS

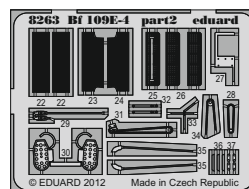
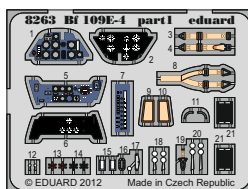

-Parts not for use. -Teile werden nicht verwendet. -Pièces à ne pas utiliser. -Tyto díly nepoužívejte při stavbě. - 使用しない部品

COLOURS



BARVY



FARBEN



PEINTURE



色

GSI Creos (GUNZE)		MISSION MODELS	
AQUEOUS	Mr.COLOR	PAINTS	
H2	C2	MMP-047	BLACK
H4	C4	MMP-007	YELLOW
H11	C62	MMP-001	FLAT WHITE
H12	C33	MMP-047	FLAT BLACK
H47	C41	MMP-012	RED BROWN
H64	C17	MMP-087	RLM71 DARK GREEN
H65	C18	MMP-088	RLM70 BLACK GREEN
H67	C115	MMP-057	RLM65 LIGHT BLUE
H70	C60	MMP-056	RLM02 GRAY
H77	C137	MMP-040	TIRE BLACK

GSI Creos (GUNZE)		MISSION MODELS	
AQUEOUS	Mr.COLOR	PAINTS	
H90	C47		CLEAR RED
H94	C138		CLEAR GREEN
H413	C113	MMP-090	RLM04 YELLOW
H416	C116	MMP-089	RLM66 BLACK GRAY
Mr.METAL COLOR		METALLICS	
	MC213	MMM-006	STEEL
	MC214	MMM-001	DARK IRON
	MC218	MMM-003	ALUMINIUM
Mr.COLOR SUPER METALLIC		METALLICS	
	SM201	MMC-001	SUPER FINE SILVER

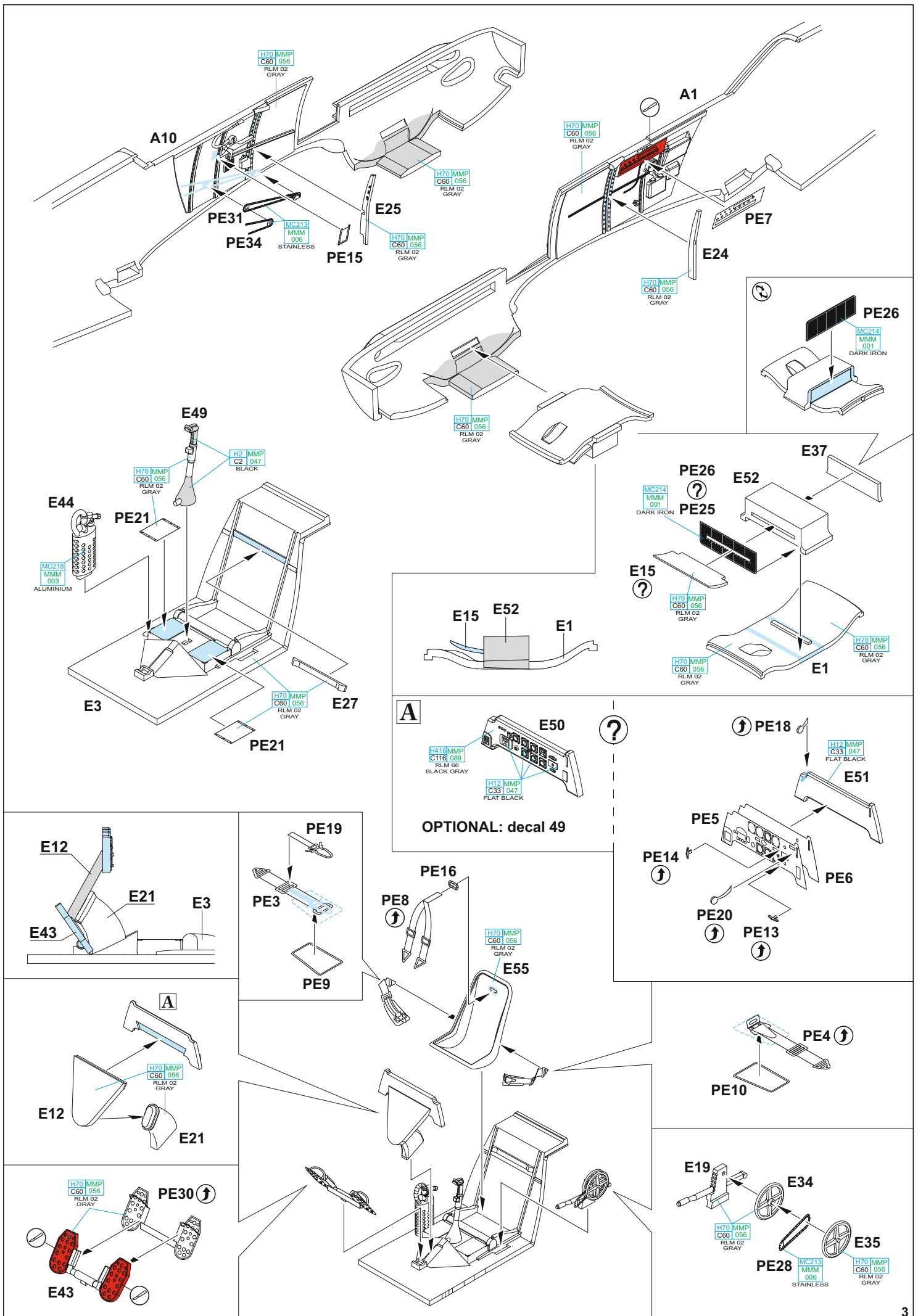

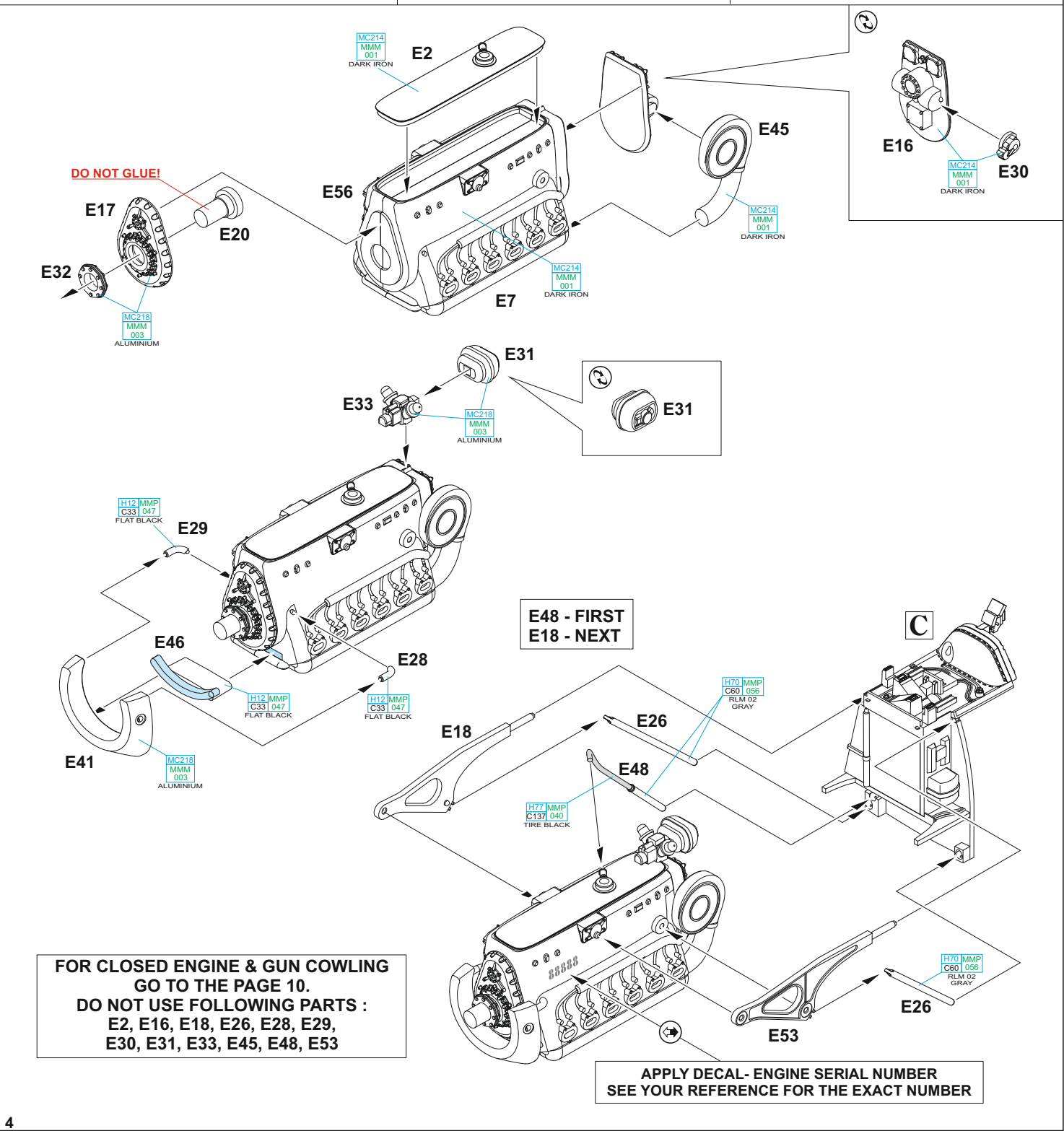
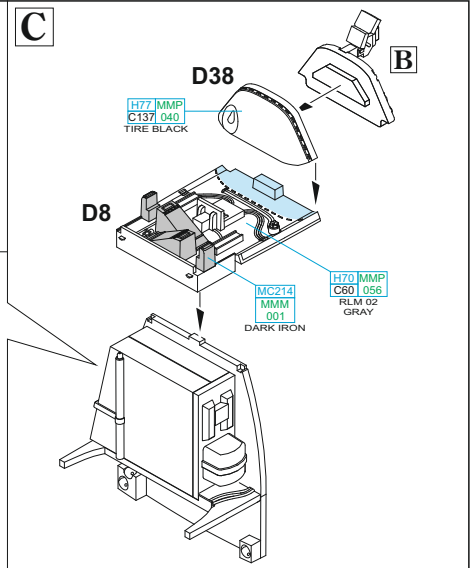
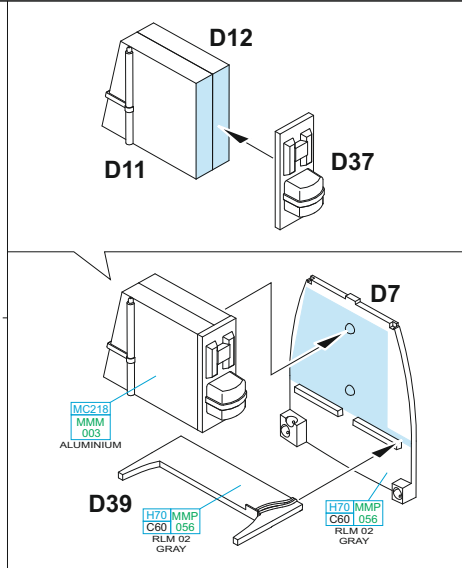
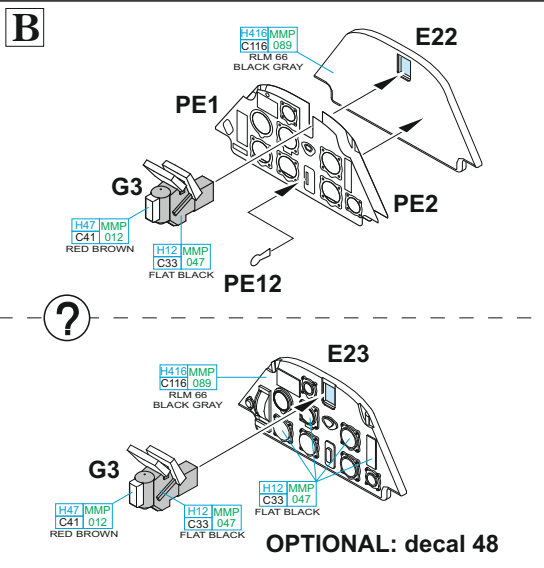

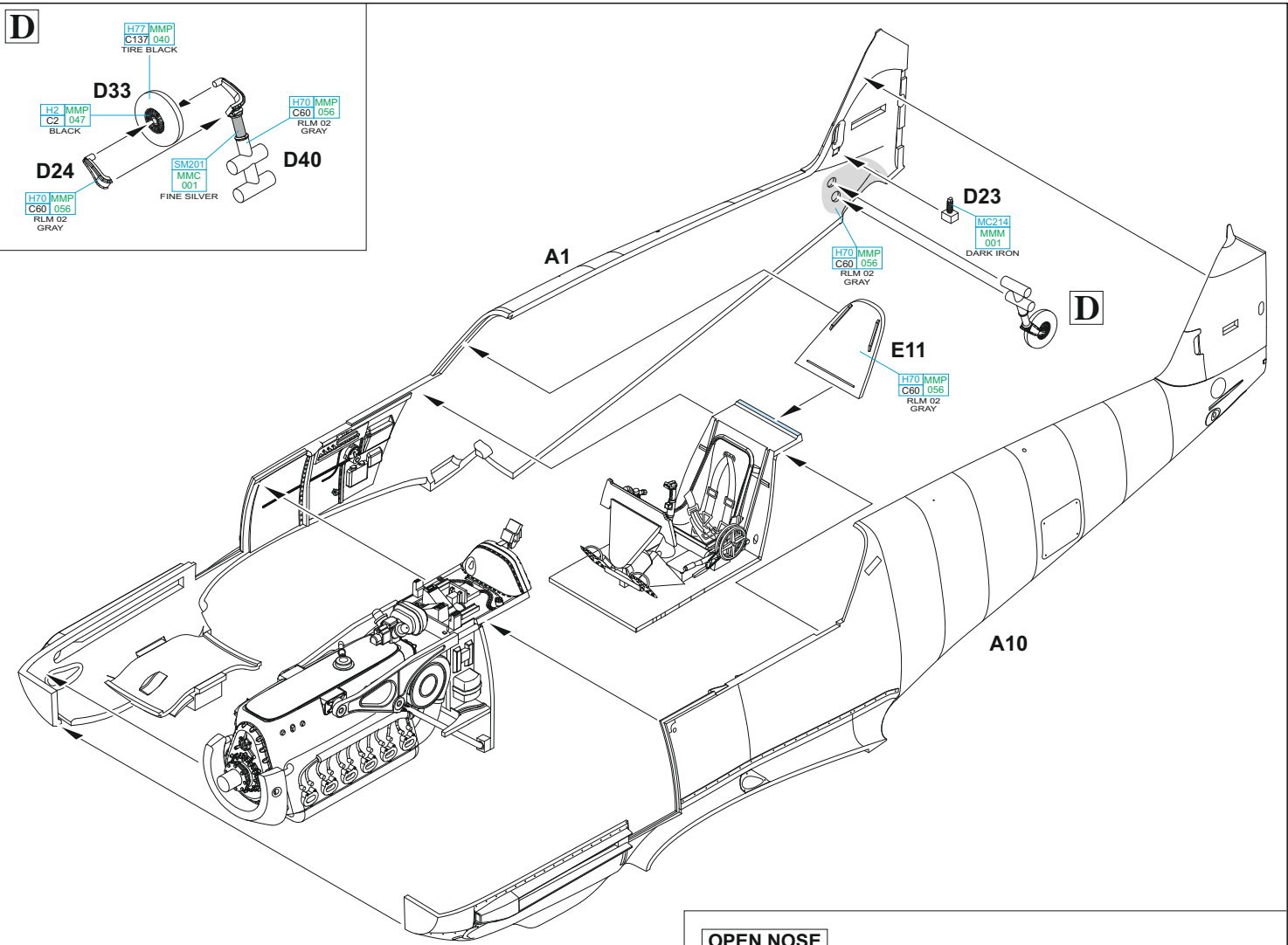

2 pcs.

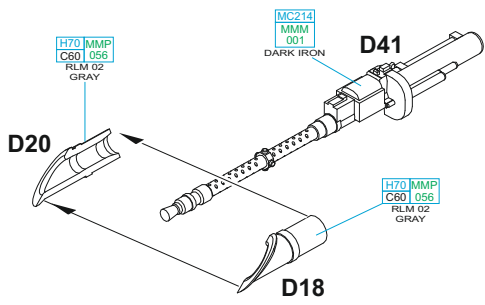

OPEN NOSE

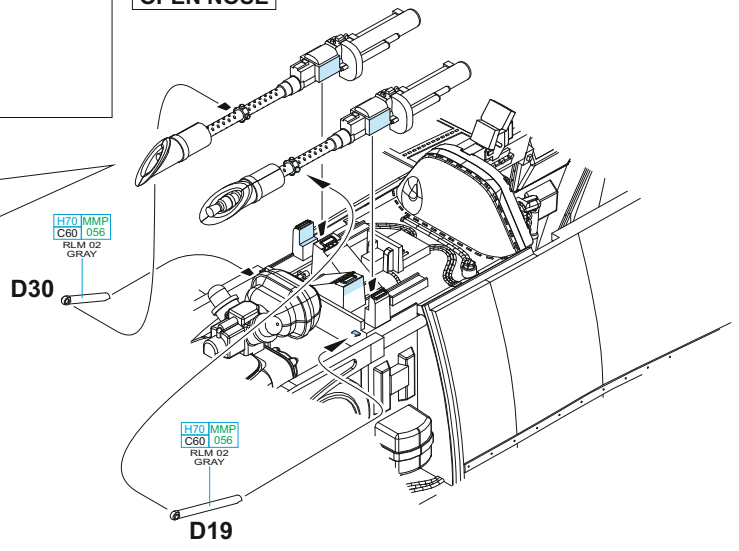

EXHAUST PIPES INSTALLATION

1.

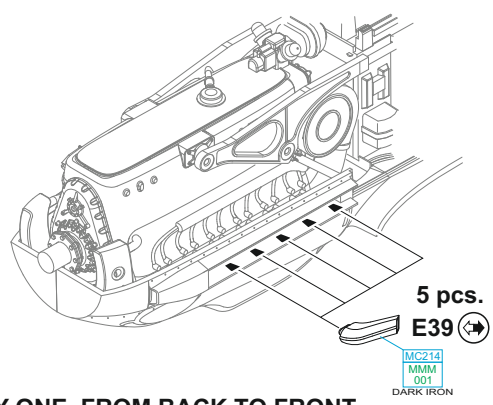

- ONE BY ONE, FROM BACK TO FRONT

2.

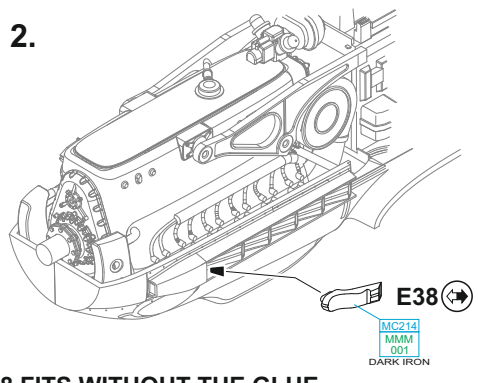

- E38 FITS WITHOUT THE GLUE

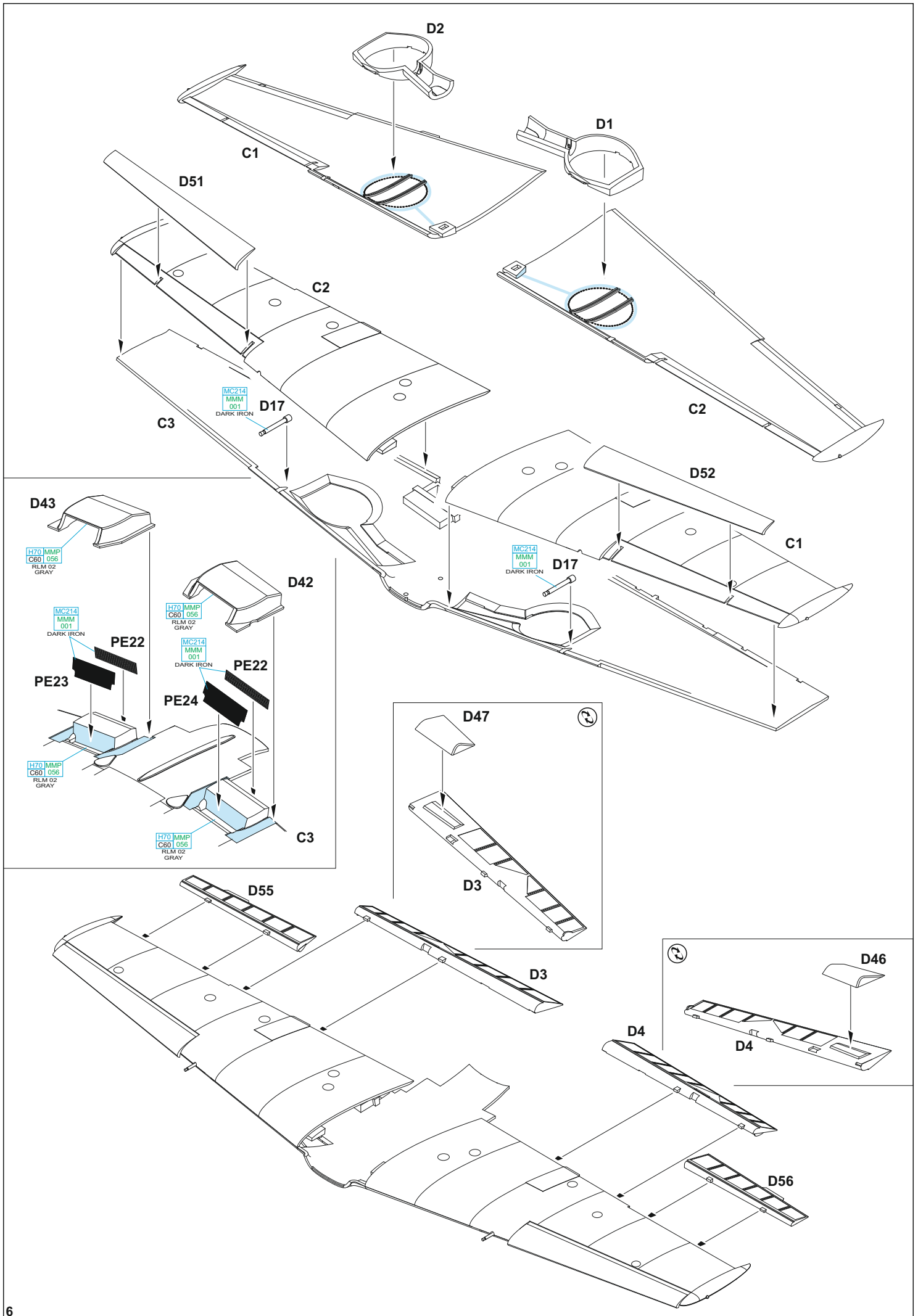

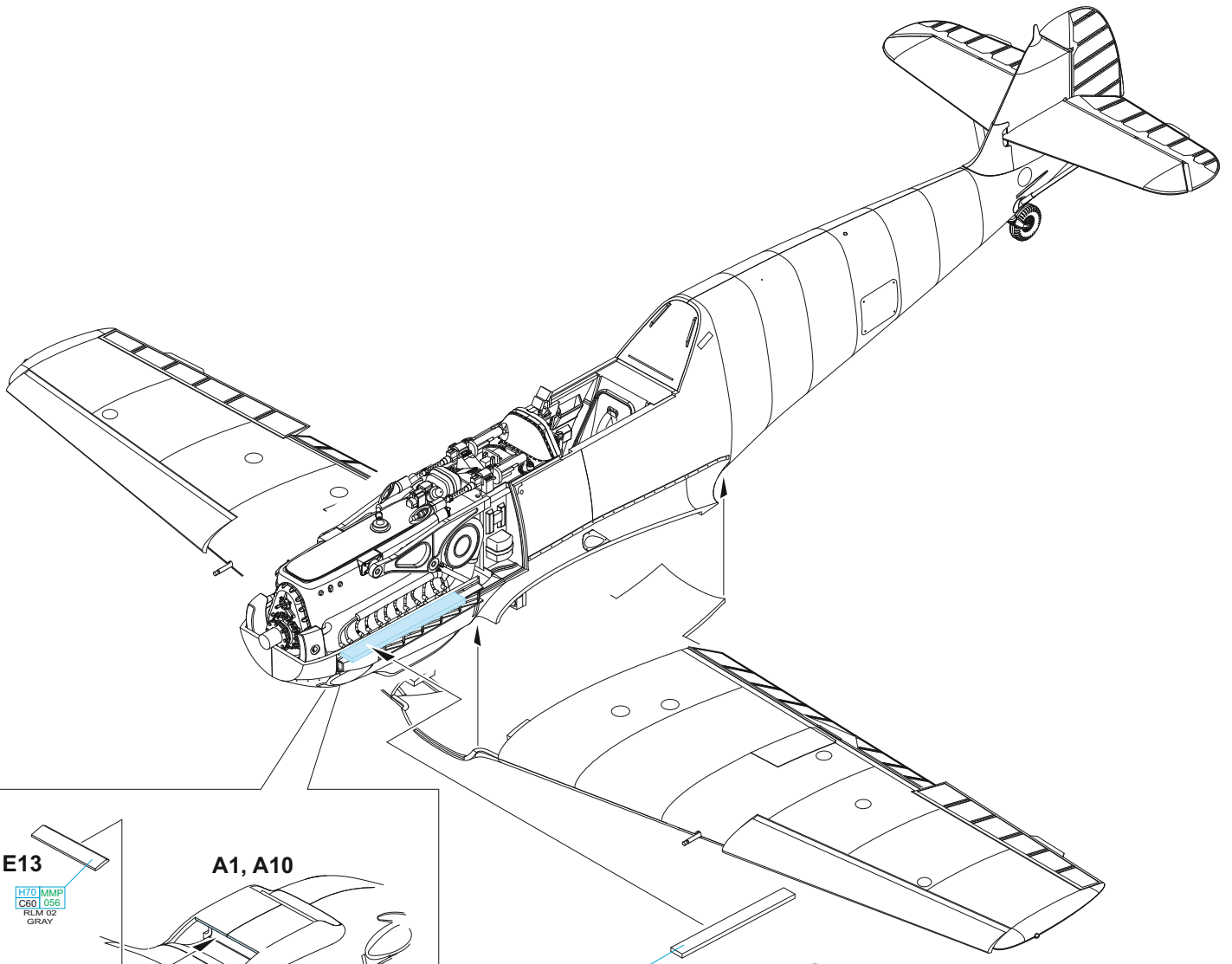

E13

H70 MMP
C60 056
RLM 02
GRAY

A1, A10

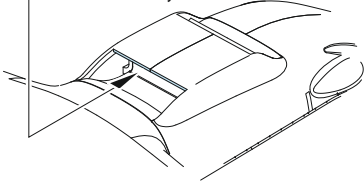

E6 starboard ↔ E5 port side

H70 MMP
C60 056
RLM 02
GRAY

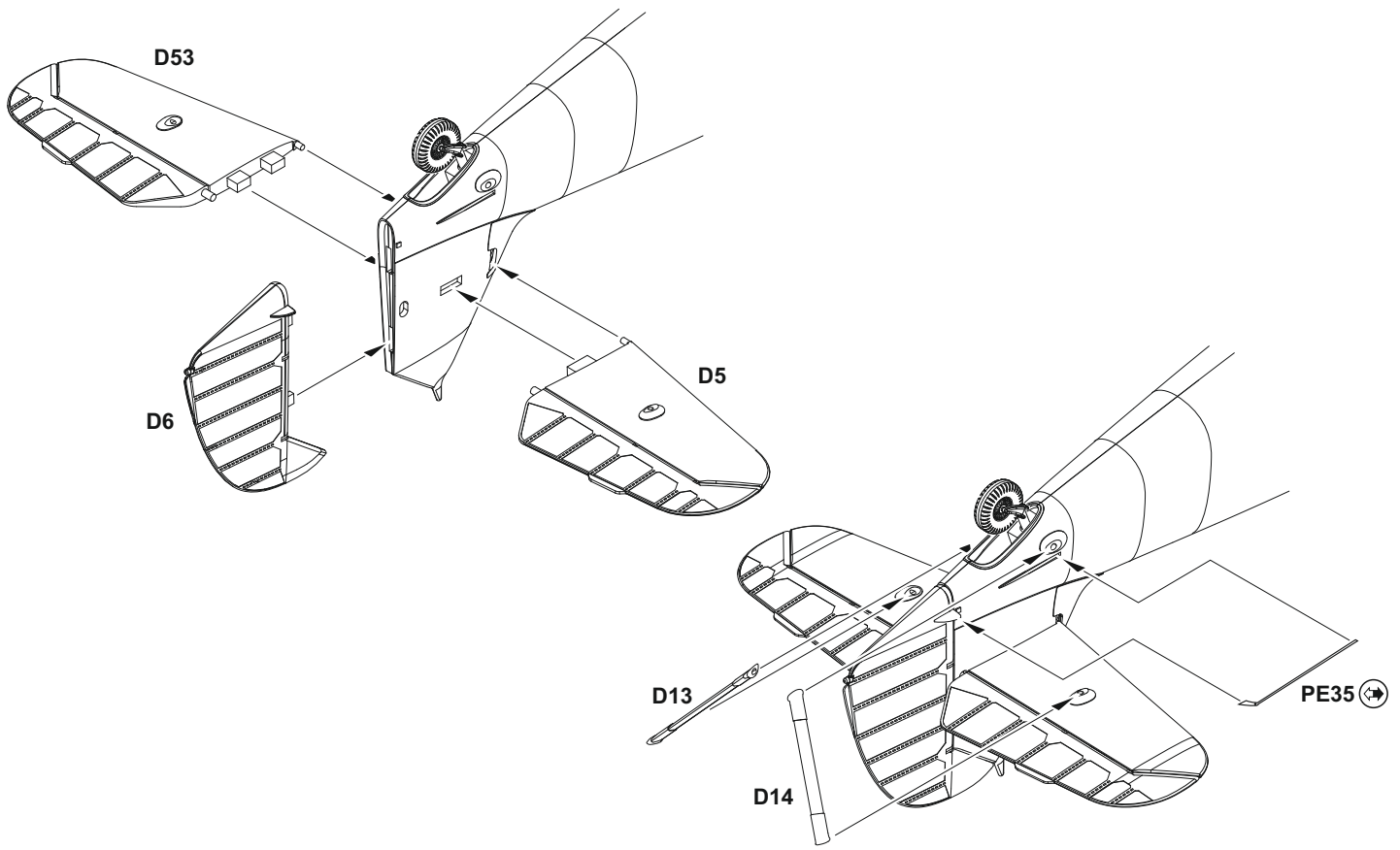

D53

D6

D5

D13

D14

PE35 ↔

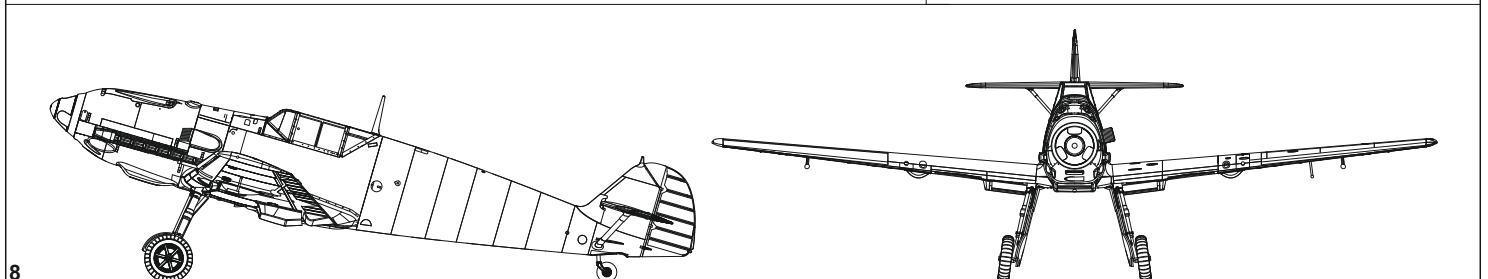
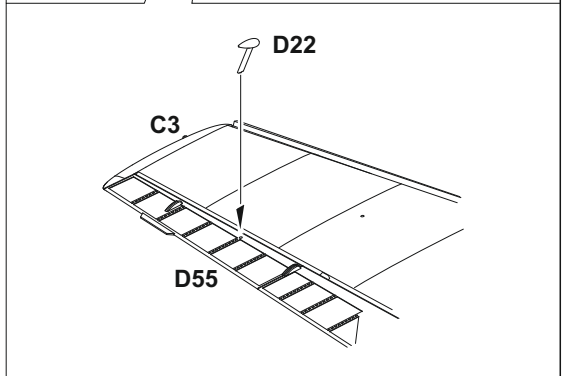
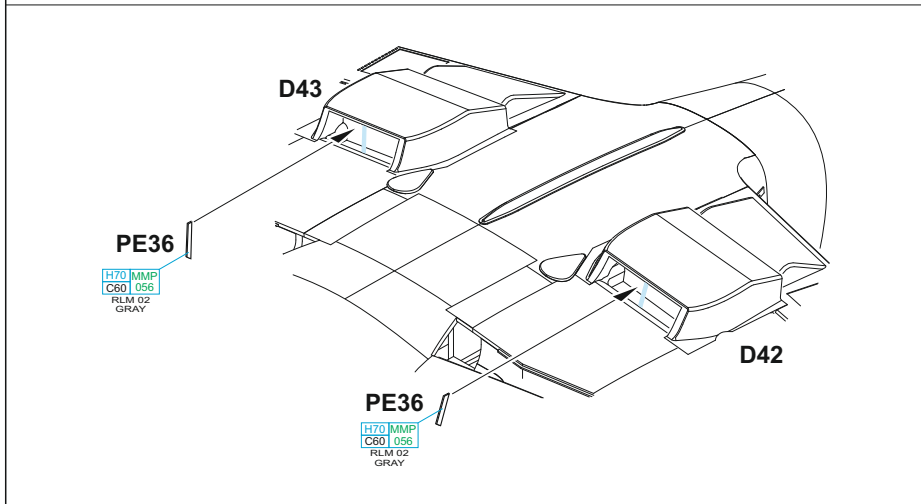
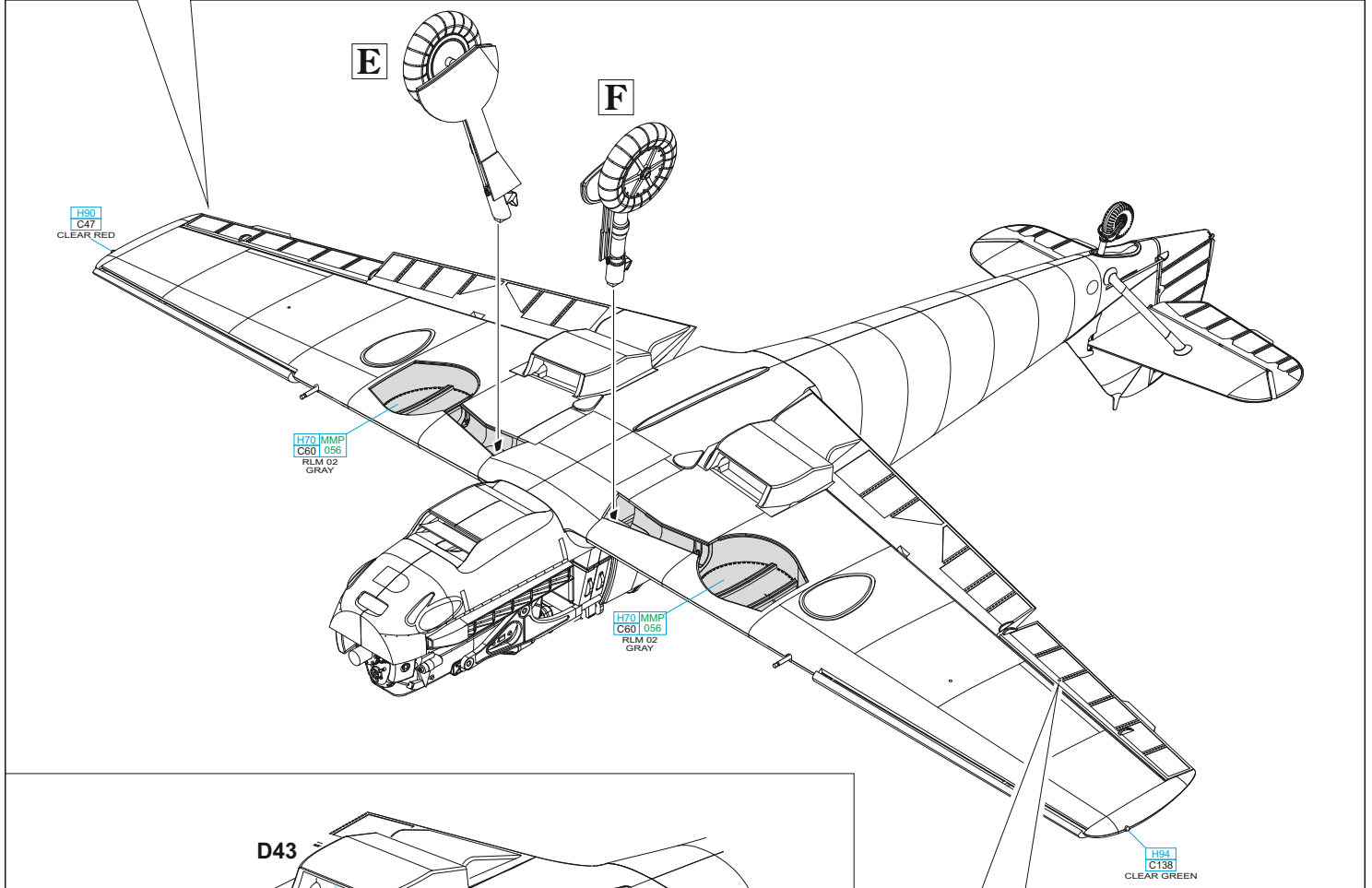
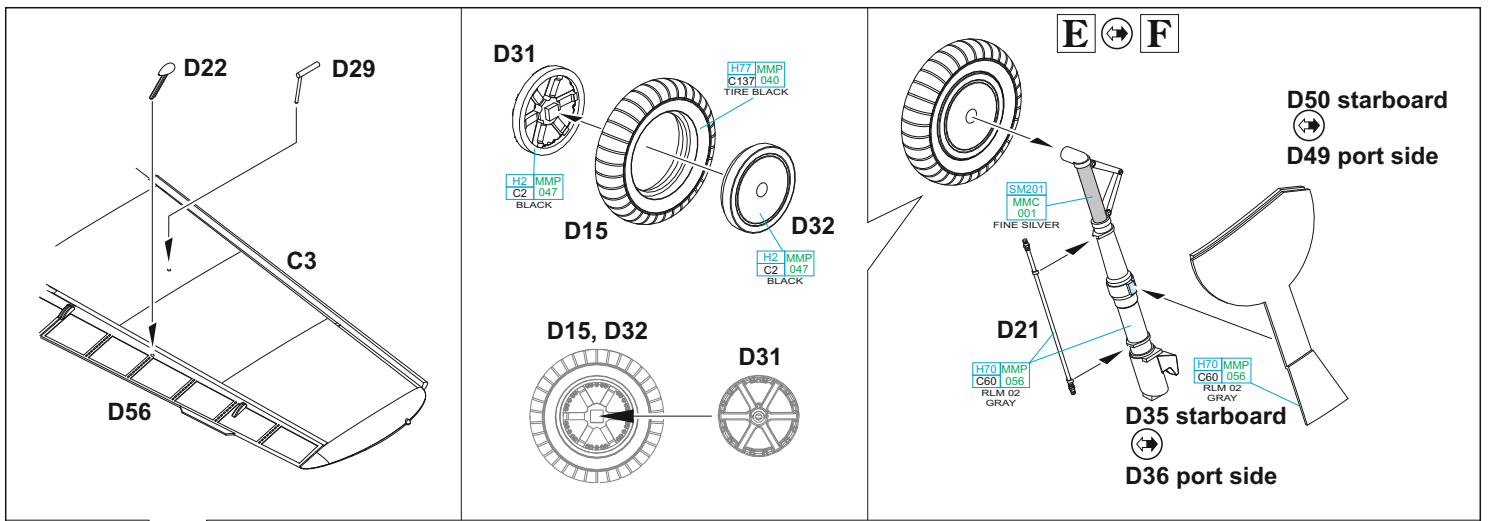

FOR CLOSED NOSE
SEE PAGE 10

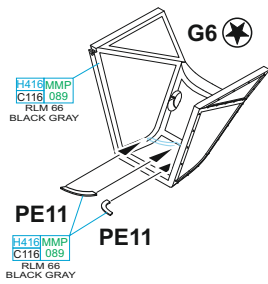
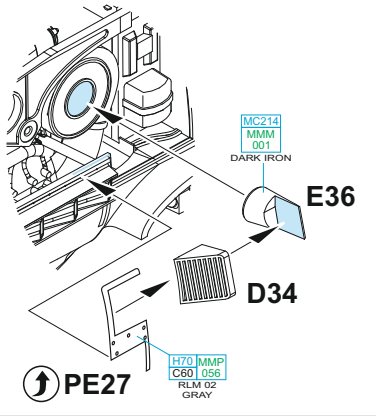
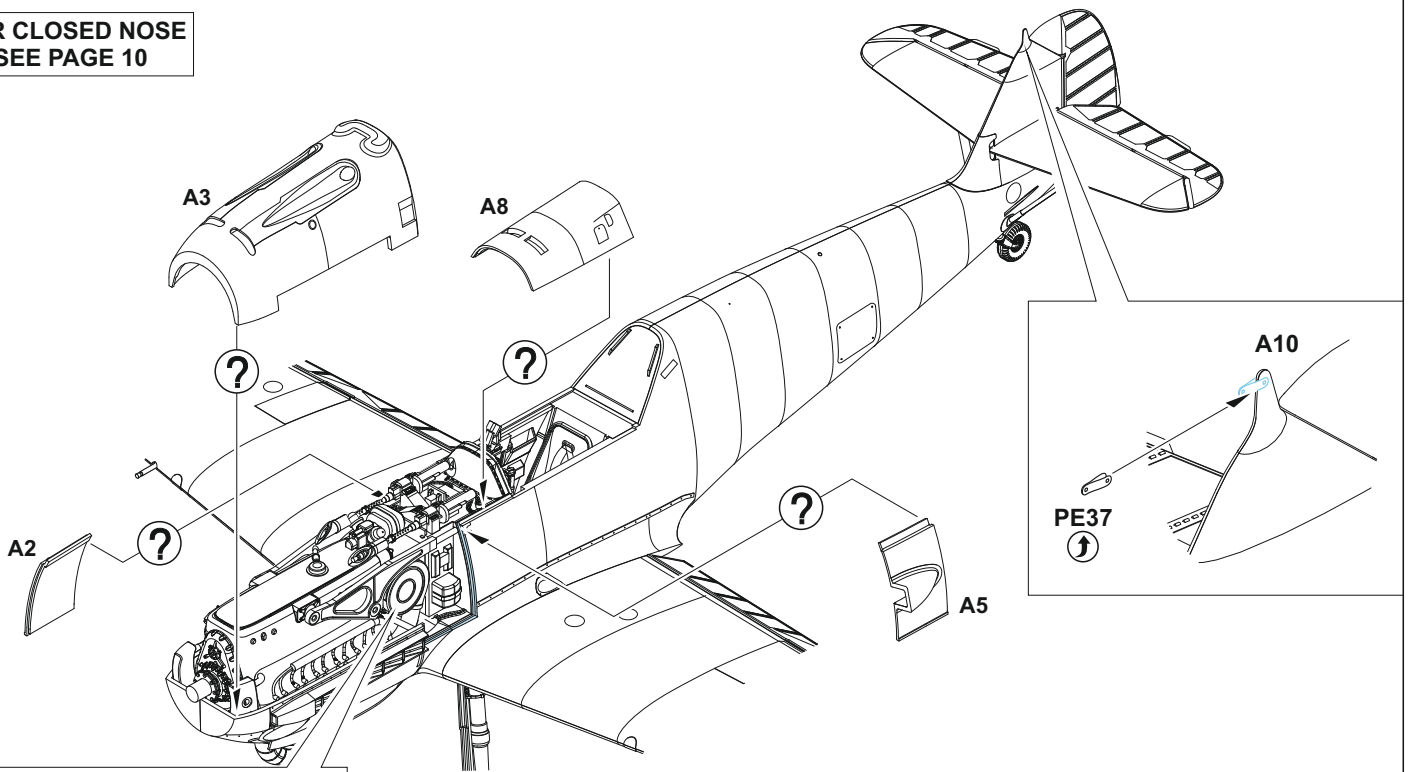

MARKING
E ONLY

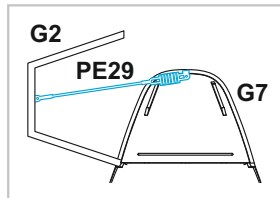
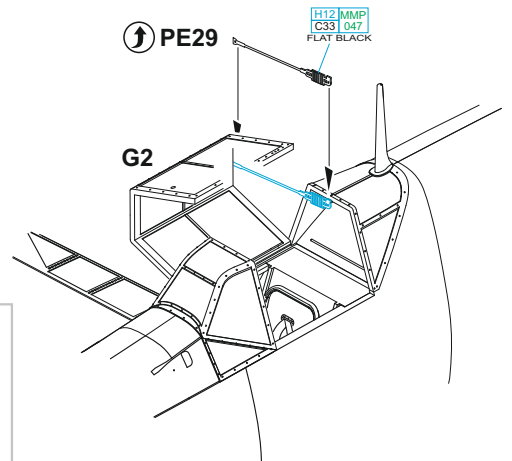
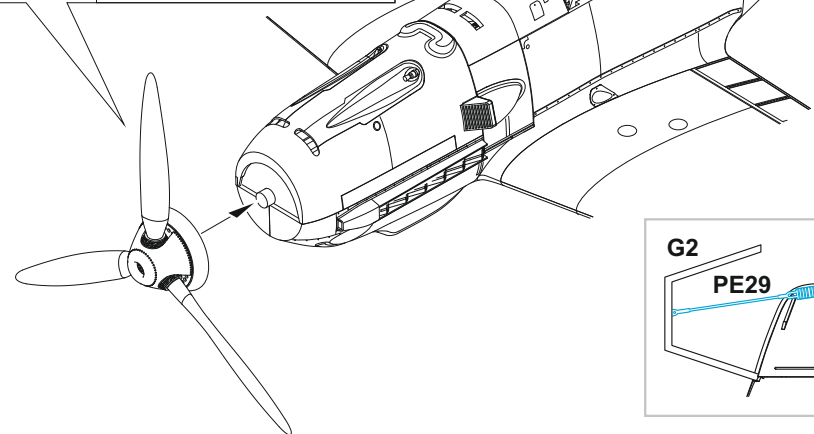
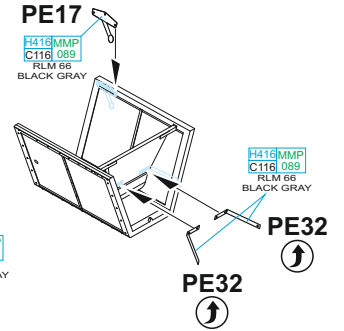
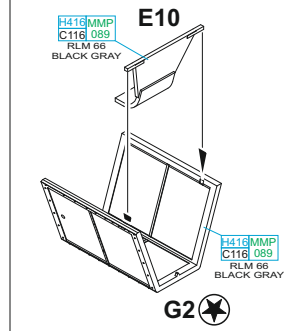
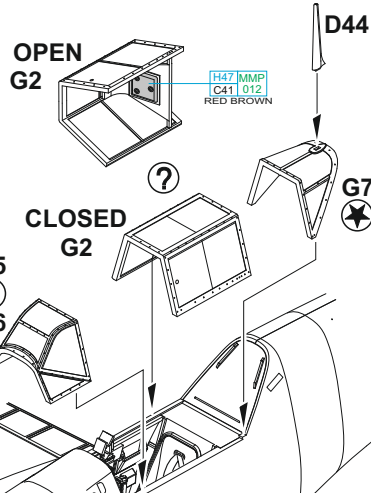
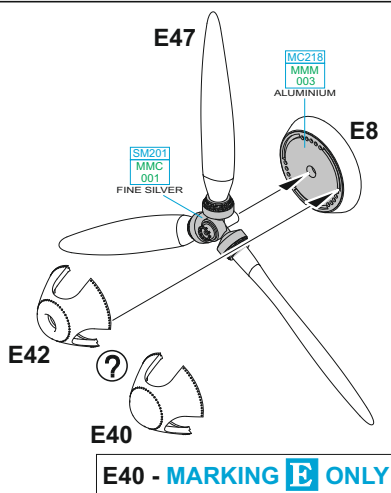
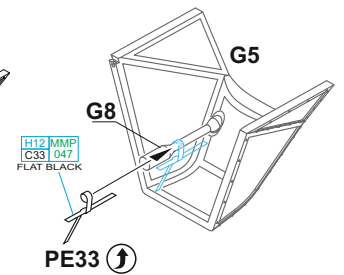
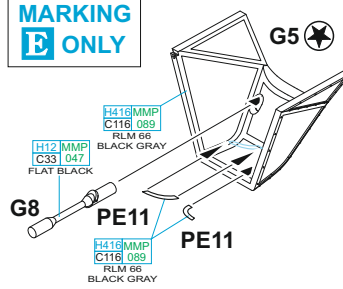

FOR CLOSED ENGINE COMPARTMENT ONLY

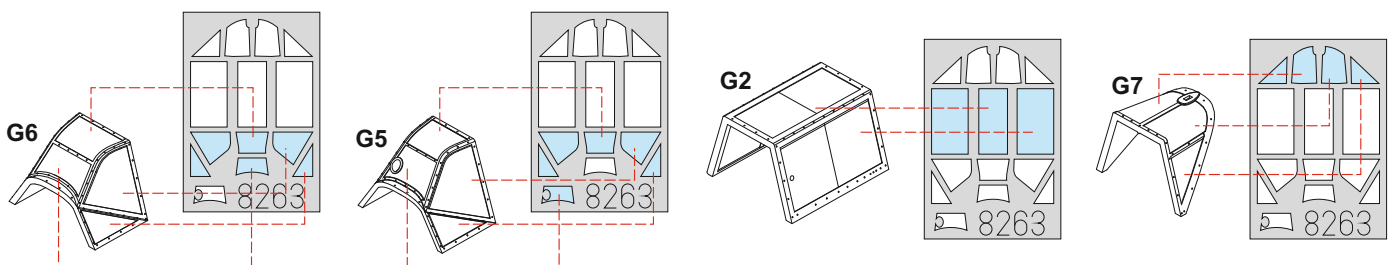
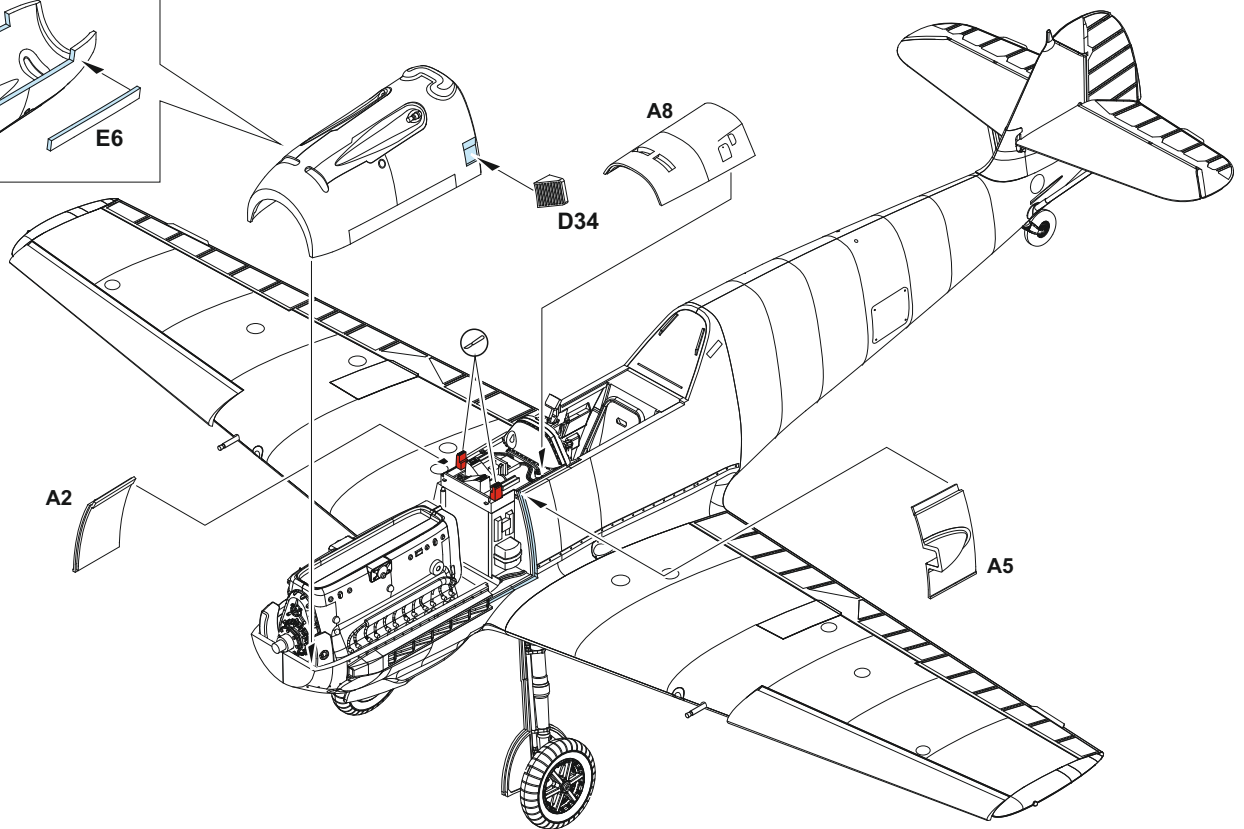
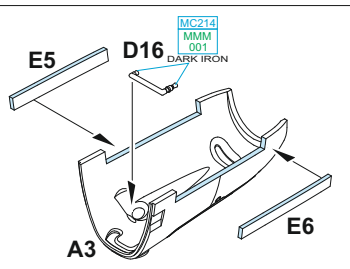
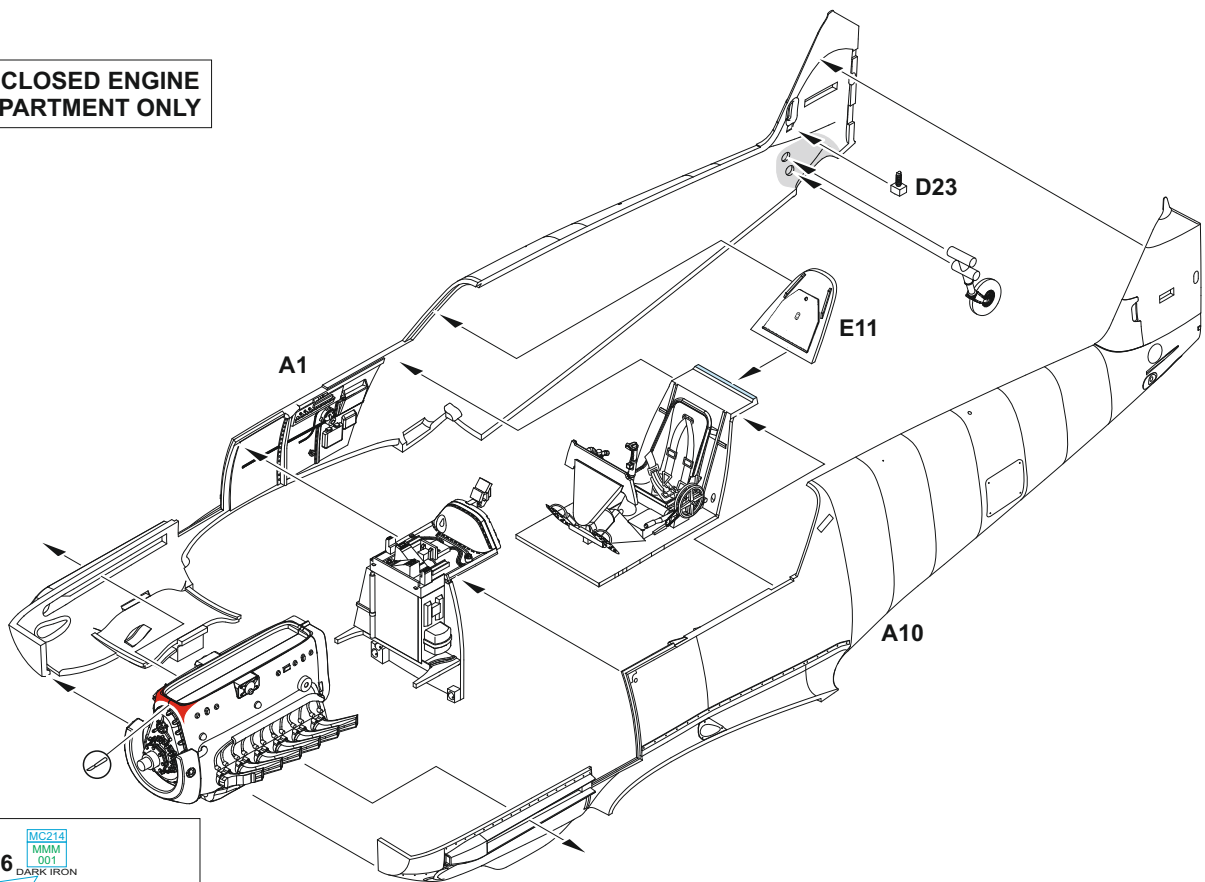

Simple but effective camouflage adorned this aircraft that shortly after noon on August 28, 1940, was shot down with Ofw. Fritz Beek at the controls in the vicinity of East Langdon. It was during the second escort mission of the day that culminated in combat with RAF fighters in which the engine of Yellow '10' was hit. After an unavoidable forced landing, the aircraft, in relatively good shape, was made otherwise by civilian vandals and allied soldiers before it could be inspected by RAF experts. Light blue sides of the RLM 02/71/65 fuselage scheme were sprayed with the upper surface colors. Yellow identification colors, typical for mid-August 1940, were applied to the wing tips, horizontal tail surfaces, and top portion of the fin. Because the aircraft in question belonged to 6. Staffel, tactical numbering and the background II./JG 51 'Gott strafe England' emblem were yellow. Three victory tabs on the left side were in white. It is not out of the question that these also appeared on the right side, but documentation is lacking.

ČESKOU VERZI TEXTU NALEZNETE NA
www.eduard.com
 POD KATALOGOVÝM ČÍSLEM 8263

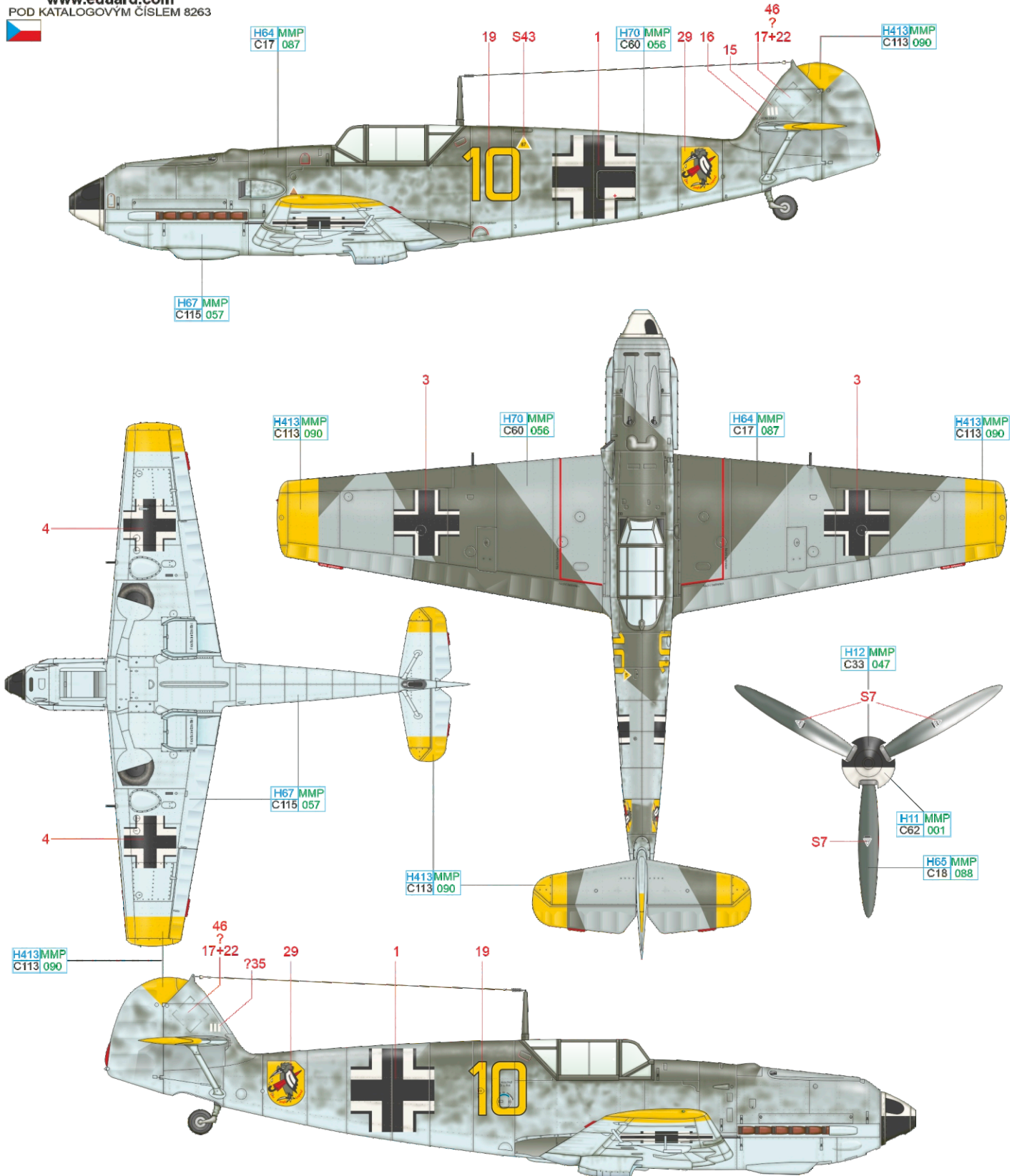

WHITE	H11 MMP C62 001	RLM 04	H413 MMP C113 090
RLM 65	H67 MMP C115 057	RLM 02	H70 MMP C60 056
		RLM 70	H65 MMP C18 088
		RLM 71	H64 MMP C17 087
		BLACK	H12 MMP C33 047

The appearance of this aircraft comes from a period in time when it was flown by Maj. Helmut Wick, and after many modifications to the camouflage scheme and tactical markings. The changes mirrored not only Wick's ascension through the ranks as Staffel CO, to Gruppe leader to commanding officer of JG 2, but also the prescribed changes to Luftwaffe camouflage specifications in the second half of 1940. Our reconstruction of the aircraft shows as it appeared in its final guise, when Maj. Wick (as the Luftwaffe's most successful ace at that time) was killed in combat with Spitfires on November 28, 1940. The aircraft carried a standard scheme of RLM 02/71/65. The light blue fuselage sides were darkened with a light overspray of RLM 71 applied with the blunt end of a brush. The yellow rudder and nose segments were part of later marking modifications. The fuselage retains evidence of the double chevron marking denoting the CO of the Gruppe. Besides the tactical markings, the JG 2 unit insignia was carried below the cockpit, and on the front fuselage, Wick's original 3. Staffel. The pilot's personal emblem, the flying kingfisher, was partly oversprayed with the Kommodor insignia, over which the emblem was partially reconstructed. This aircraft had the armored windscreen removed towards the end of its career, but was still mounted when Wick led I./JG 2. One interesting point regarding the national markings on the bottom of the wings and fuselage sides that was present on many JG 2 Emils, including Wick's 5344, was that the fuselage markings had an accentuated black border at the expense of the white segments, while those on the bottom of the wings were modified as indicated in our illustrations.

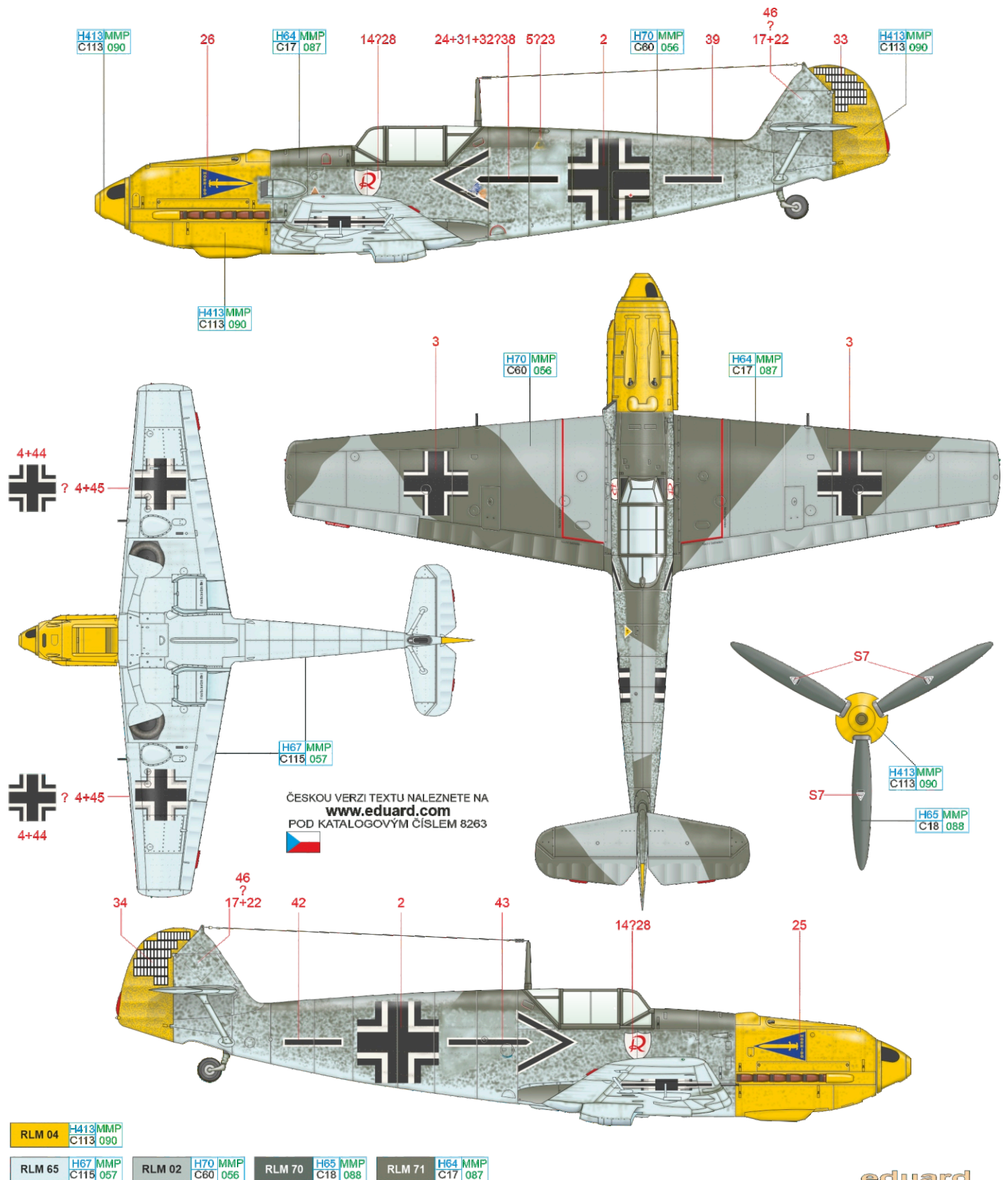

D W.Nr. 1480, Oblt. Franz von Werra, Gruppenadjutant II./JG 3, Wierre-au-Bois, France, September 5, 1940

The illustrated Emil became the subject of a fascinating event that delivered the first German ace, Oblt. Franz von Werra, into British hands. On the morning of September 5, 1940, Franz von Werra was shot down over Kent. He managed a successful belly landing, was taken prisoner, and his plane was scrutinized by RAF experts. Von Werra attempted to escape on several occasions, and finally succeeded in Canada during transfer to a POW camp. He managed to go through the United States to South America, and then back to Germany, where he rejoined the Luftwaffe. He served on both the eastern and western fronts, but had strict orders to avoid the shores of England. The Channel, nevertheless, proved fateful for him when, on October 25, 1941 as CO of I./JG 53, he disappeared over it. W.Nr. 1480 carried the standard camouflage of RLM 02/71/65 with white identification markings. These included the rudder and wingtips. The RAF report suggests that the engine cowl was in RLM 65, was cleaner than the rest of the airframe, and may have been a replacement off another machine. The tail surfaces carried victory marks (eight in the air and five on the ground). Positioning of them was different on each side of the fin. The RLM 65 color extended to the upper surfaces of the leading edge wing.

ČESKOU VERZI TEXTU NALEZNETE NA
www.eduard.com
 POD KATALOGOVÝM ČÍSLEM 8263

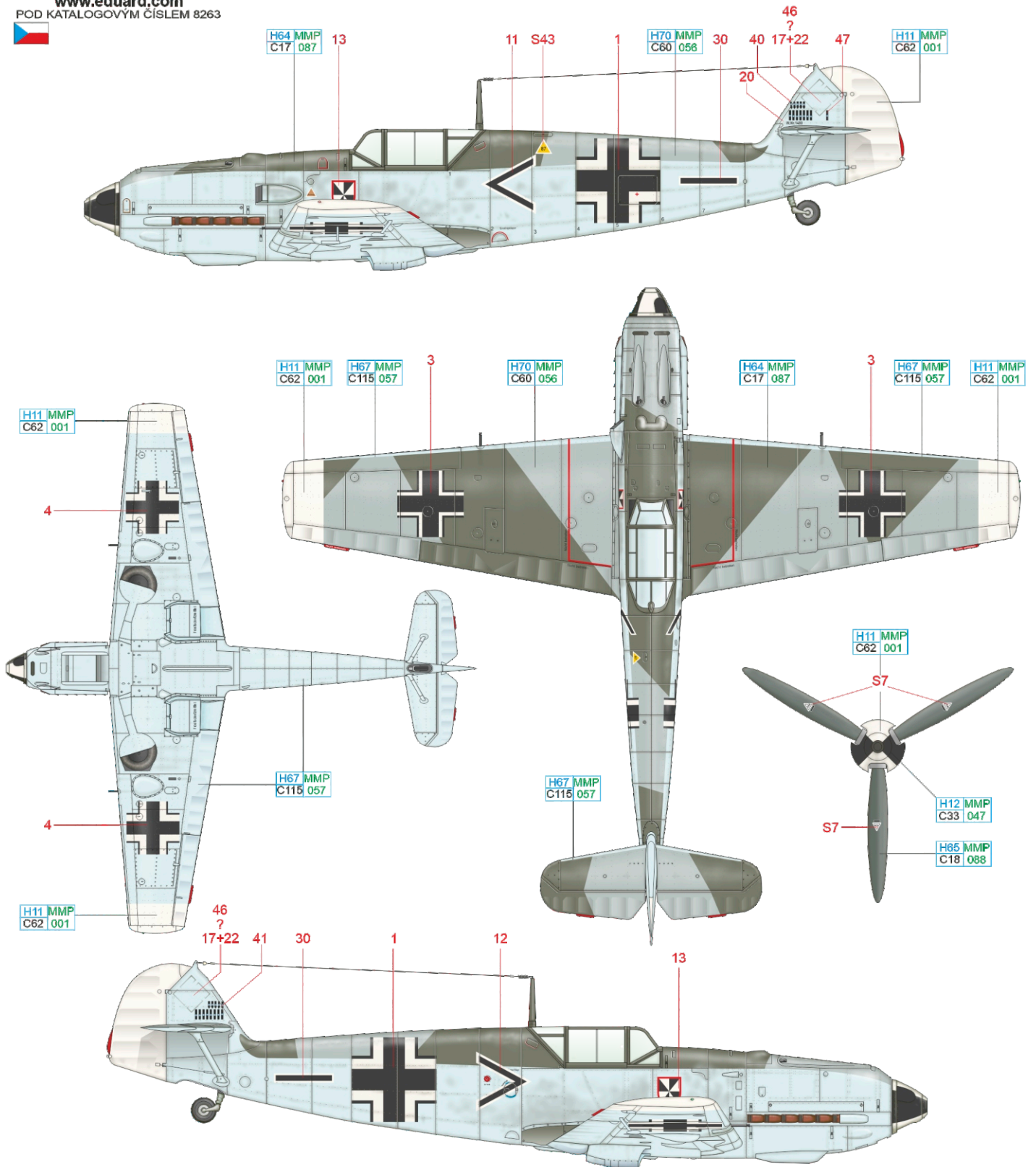

WHITE	H11 MMP C62 001	RLM 65	H67 MMP C115 057	RLM 02	H70 MMP C60 056	RLM 70	H65 MMP C18 088	RLM 71	H64 MMP C17 087	BLACK	H12 MMP C33 047
-------	-----------------	--------	------------------	--------	-----------------	--------	-----------------	--------	-----------------	-------	-----------------

Adolf Galland, ace and future General, flew the illustrated Emil in the fall of 1940 to the beginning of 1941 as CO of III. Gruppe, and later of the entire JG 26. The tactical markings on the aircraft kept pace with those changes. The standard camouflage of RLM 02/71/65 was darkened on the fuselage sides with RLM 02/71. The yellow cowling was complemented by the yellow rudder that also bore the kill marks. The surface area of the original RLM 65 was not enough for them, and the yellow was oversprayed with fresh RLM 65 for the next row of kill marks. The most typical changes for 5819 at this time came with the personal emblem of Mickey Mouse and most of all the installation of the ZFR-4 telescope (installed together with the regular Revi). It didn't serve as an actual sight as it did for the identification of far off aircraft. Galland replaced Werner Mölders who commanded the German fighter force as General der Jagdflieger. Later on he became famous for locking horns with Hermann Göring. He established JV 44 at the end of the war, the famous unit well known for its Me 262 jet fighters and colorful Fw 190D piston fighters. Galland managed to shot down 104 enemy airplanes and was awarded with Knight Cross with Oak Leaves, Swords and Diamonds.

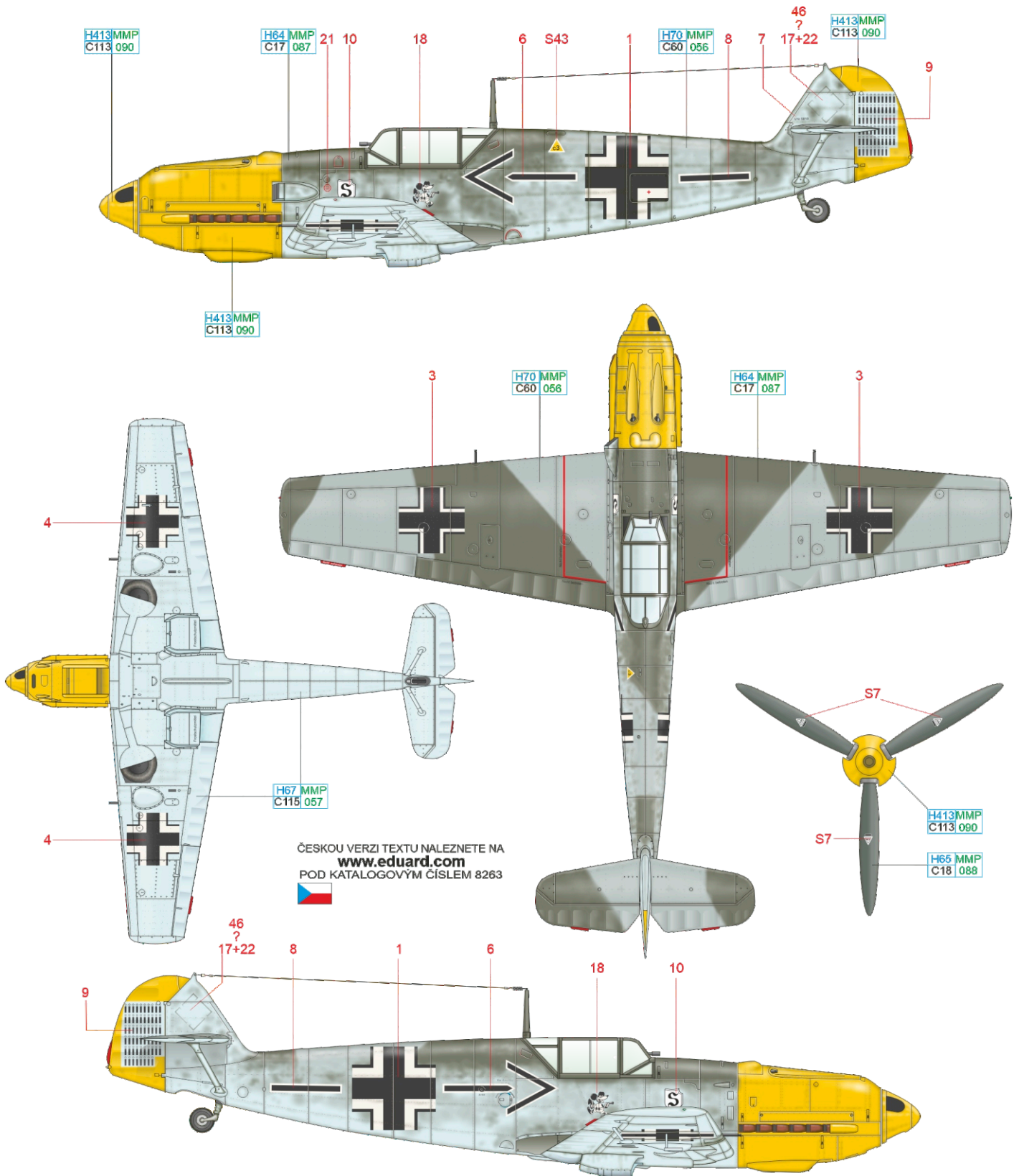

ČESKOU VERZI TEXTU NALEZNETE NA
www.eduard.com
 POD KATALOGOVÝM ČÍSLEM 8263

- RLM 04 H413 MMP C113 090
- RLM 65 H67 MMP C115 057
- RLM 02 H70 MMP C60 056
- RLM 70 H65 MMP C18 088
- RLM 71 H64 MMP C17 087

