

Spitfire Mk.IXc early version

eduard

BRITISH WWII FIGHTER

1/48 SCALE PLASTIC KIT

ProfiPACK
edition

#8282



INTRO

In September 1941, a hitherto unknown German radial engine fighter appeared in the west European sky. The new airplane was superior to British fighters, most distressingly to the Spitfire Mk.V. The German design was soon recognized as the Focke-Wulf Fw 190A. The losses suffered by the RAF over western Europe rose rapidly and the crisis was serious enough that the RAF ceased the majority of daytime operations in November 1941. The next attempt to resume these types of sorties was made in March 1942. Loss rates remained unacceptably high and the RAF was forced to stop ops once again. All this was thanks to the Focke-Wulf Fw 190A. The first response to the new German weapon was the Spitfire Mk.VIII, but the design changes were so complex that initiating timely production was not possible. In June 1942, a German pilot landed by mistake on a British airfield delivering a completely intact Fw 190 fighter into RAF hands. Comparative trials between the Focke-Wulf and Spitfire Mk.V began almost immediately. These mock encounters confirmed the situation over the front – the chances of a British fighter surviving an encounter with the Fw 190 were slim. The only British fighter aircraft deemed suitable to oppose them were the Spitfire Mk. VII and VIII powered by the Merlin 61 engine. As mentioned above these were some time away of being ready for series production. But there was another way of getting a powerful fighter quickly - by mating the Merlin 61, with its two-stage supercharger, with the fuselage of the Spitfire Mk.Vc. Two Mk.Vc airframes, AB196 and AB197, were selected for this purpose and were strengthened with modified longerons to accommodate the more powerful and heavier engine. The example was finished on February 26 and the second on March 27, 1942. Flight trials were successful and the order for series production was issued almost immediately. Series production began in June 1942 and the first Mk.IXs found their way to No. 64 Squadron in July. Performance improved significantly in comparison to the Mk.V. A top speed of 409 mph at 28,000 feet was higher by 40mph, and the service ceiling rose from 36,200 to 43,000 feet. The Mk.IX could climb at 4,000 feet per minute. The RAF finally had a fighter aircraft capable of opposing the Fw 190A. Three main versions of the Mk.IX were produced. The F.IX was powered by the Merlin 61 and was the only version on the assembly line in early 1943. The next version was the LF Mk.IX powered by the Merlin 66. This engine was designed to do its best at low altitudes. The third version, manufactured along with the LF, was the high-altitude HF Mk.IX with the Merlin 70. The majority of Mk.IXs manufactured were equipped with the so-called 'C' wing. Four 20mm cannon or two 20mm cannon and four .303 machine guns could be installed in the wings. From 1944, the strengthened 'E' wing was produced. Four .303 machine guns were replaced with two .50 heavy machine guns. Bomb racks for 250lb bombs were fitted under each wing typically. The Mk.IX became the second most numerous version of the Spitfire with a total of 5653 examples being built. The Mk.IX began to replace the Mk.V from June 1942. Thanks to the new fighter, the RAF was ready to fight against the Luftwaffe over occupied Europe. Spitfire Mk.IXs served with the RAF to the end of war. In the postwar era, foreign air forces flew this version as well. Czechoslovak, Norwegian, Danish, and Canadian air forces operated numbers of Mk.IXs and they were not alone. Spitfires would find themselves in combat again. Czechoslovakia sold its Spitfire Mk.IXs to Israel in 1948 and these aircraft formed the backbone of the newly born Israeli air force in the fight against their Arab neighbours.

ÚVODEM

V září 1941 se na evropské obloze objevil dosud neznámý německý stíhací letoun poháněný hvězdicovým motorem. Nová stíhačka měla nad britskými, zejména Spitfirem Mk.V, zřetelnou převahu. V německé konstrukci byl záhy rozpoznán Focke-Wulf Fw 190A. Ztráty RAF nad západní Evropou začaly rychle narůstat až to té míry, že britské letectvo muselo v listopadu 1941 zastavit většinu denních operací nad evropským kontinentem. Pokus o spuštění tohoto typu bojových letů byl uskutečněn v březnu 1942. Počty ztrát však byly opět neúnosné, což opět vedlo k jejich zastavení. Vše díky Focke-Wulfům Fw 190A. Prvním pokusem o odpověď na novou německou zbraň se stal Spitfire Mk.VIII, avšak komplexní přístup ke změnám konstrukce letounu způsobil, že nebylo možné jej dostat do sériové výroby v dostatečně blízkém časovém horizontu. V červnu 1942 přistál jeden z německých pilotů omylem na britském letišti a předal tak do britských rukou nepoškozený Fw 190A. Srovnávací zkoušky Focke-Wulfu a Spitfire Mk.V začaly téměř neprodleně. Cvičné souboje plně potvrdily situaci na frontě – šance britské stíhačky přestat setkání s Fw 190 bez úhony nebyly vysoké. Jediné britské stíhačky schopné postavit se plnohodnotně německému typu byly Spitfire Mk.VII a Mk.VIII poháněné motorem Merlin 61. Jak však bylo poznamenáno výše, nedalo se čekat, že v dohledné době dospějí do fáze sériové výroby. Byla zde však ještě jedna cesta, jak získat dostatečně výkonnou stíhačku – zabudovat Merlin 61 s dvoustupňovým kompresorem do základního draku Spitfire Mk.V. Pro tento experiment byly vyčleněny dva draky, AB196 a AB197. Prošli zpevněním, aby mohl být zastaven výkonnější a těžší motor. První z nich byl dokončen 26. února, druhý pak 27. března 1942. Letové testy proběhly natolik úspěšně, že byla objednána sériová výroba. Ta se plně rozběhla v červnu 1942 a první Mk.IX se u bojové jednotky, 64. squadrony, objevily v červenci. V porovnání s Mk.V se výkony znatelně zvýšily. Maximální rychlost byla v 28.000 stopách vyšší o 40 mph, operační dostup se zvýšil z 36.200 na 43.000 stop. Mk.IX mohl stoupat rychlostí 4000 stop za minutu. RAF tedy konečně dostalo stíhačku, kterou mohlo směle postavit proti Fw 190A. Vyráběny byly tři hlavní verze Mk.IX. Verze F Mk.IX byla poháněna motorem Merlin 61 a z montážní linky sjížděla až do počátku roku 1943. Na ni navázaly LF Mk.IX poháněná motorem Merlin 66 a určená k operacím v nižších výškách, a HF Mk.IX s motorem Merlin 70 konstruovaným naopak pro výškové lety. Většina Mk.IX byla vyrobena s křídlem typu C. V něm mohla být instalována výzbroj složená ze čtyř kanonů ráže 20 mm nebo ze dvou kanonů ráže 20 mm a čtyř kulometů ráže 0.303 palce. V roce 1944 se objevilo zpevněné křídlo typu E. Čtveřice 0.303 kulometů byla nahrazena dvojicí kulometů ráže 0.50 palce. Pod každou polovinou křídla byly standardně namontovány závěsníky pro 250lb pumy. Verze Mk.IX se stala druhou nejpočetnější verzí Spitfire s 5653 vyrobenými kusy. Mk.IX začaly nahrazovat Mk.V v červnu 1942. Díky nové stíhačce byla RAF opět schopná bojovat proti Luftwaffe nad okupovanou Evropou. Ve své výzbroji si typ ponechala až do konce války. Po ukončení bojů se verze dostala i do výzbroje dalších letectev. Československé, norské, dánské, kanadské a další letectva používala desítky Mk.IX. Spitfire Mk.IX se však do bojů dostaly i v této době. Československo prodalo své Spitfirey v roce 1948 do Izraele, kde se v bojích s arabskými sousedy staly páteřním typem nově vznikajících izraelských vzdušných sil.

ATTENTION



UPOZORNĚNÍ



ACHTUNG



ATTENTION



注意



Carefully read instruction sheet before assembling. When you use glue or paint, do not use near open flame and use in well ventilated room. Keep out of reach of small children. Children must not be allowed to suck any part, or pull vinyl bag over the head.



Před započítím stavby si pečlivě prostudujte stavební návod. Při používání barev a lepidla pracujte v dobře větrané místnosti. Lepidla ani barvy nepoužívejte v blízkosti otevřeného ohně. Model není určen malým dětem, mohlo by dojít k požití drobných dílů.

INSTRUCTION SIGNS * INSTR. SYMBOLS * INSTRUKTION SINNBILDEN * SYMBOLES * 記号の説明

OPTIONAL
VOLBABEND
OHNOUOPEN HOLE
VYVRTAT OTVORSYMMETRICAL ASSEMBLY
SYMETRICKÁ MONTÁŽREMOVE
ODŘÍZNOUTREVERSE SIDE
OTOČITAPPLY EDUARD MASK
AND PAINT
POUŽÍT EDUARD MASK
NABARVIT

PARTS



DÍLY



TEILE



PIÈCES



部品

PLASTIC PARTS

A>

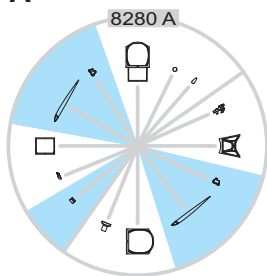

B>

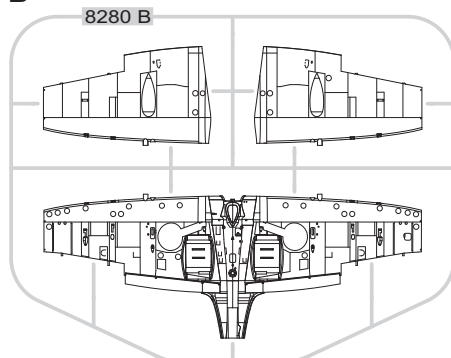

C>

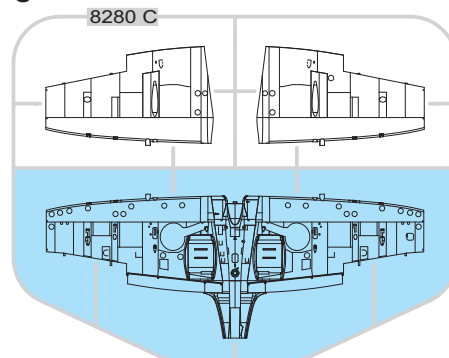

E>

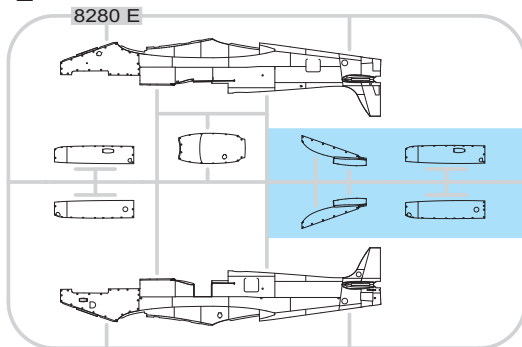

F>

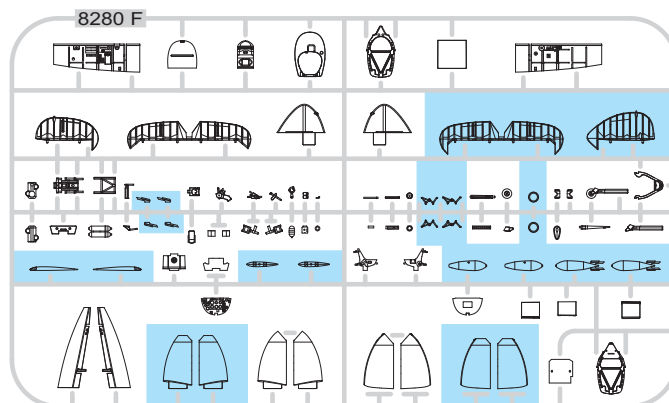

G>

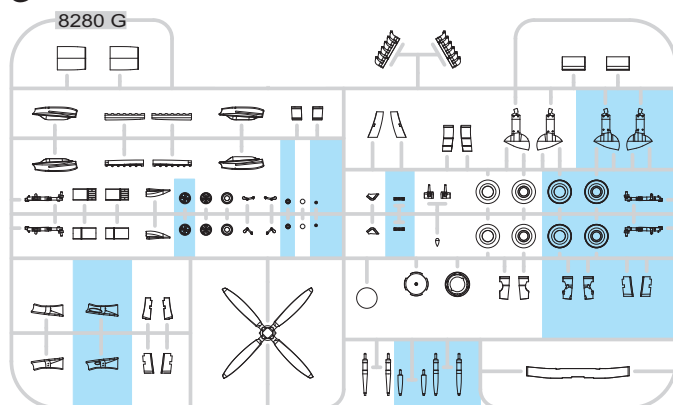

PE - PHOTO ETCHED DETAIL PARTS

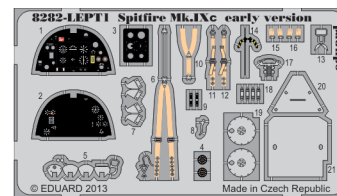
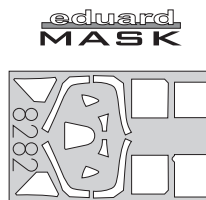

-Parts not for use. -Teile werden nicht verwendet. -Pièces à ne pas utiliser. -Tyto díly nepoužívejte při stavbě. - 使用しない部品

COLOURS



BARVY



FARBEN



PEINTURE



色

GSI Creos (GUNZE)		
AQUEOUS	Mr.COLOR	
H 4	C4	YELLOW
H 12	C33	FLAT BLACK
H 13	C3	FLAT RED
H 33	C81	RUSSET
H 51	C11	LIGHT GULL GRAY
H 71	C21	MIDDLE STONE
H 72	C369	DARK EARTH
H 77	C137	TIRE BLACK
	C361	MEDIUM SEAGRAY

AQUEOUS	Mr.COLOR	
	C382	OCEAN GRAY
	C363	DARK GREEN
	C364	AIRCRAFT GRAY GREEN
	C368	SKY
	C370	AZURE BLUE
Mr.METAL COLOR		
	MC214	DARK IRON
	MC218	ALUMINIUM
Mr.COLOR SUPER METALLIC		
	SM03	CHROME SILVER

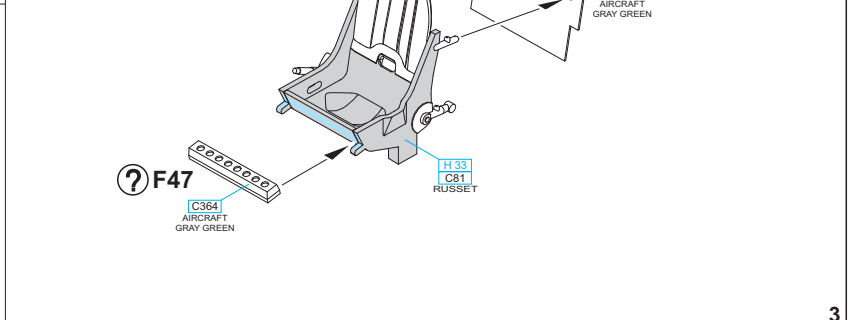
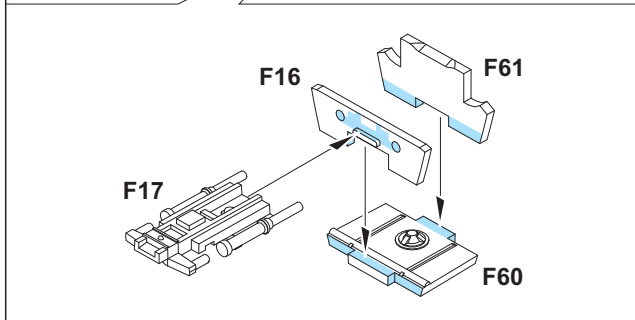
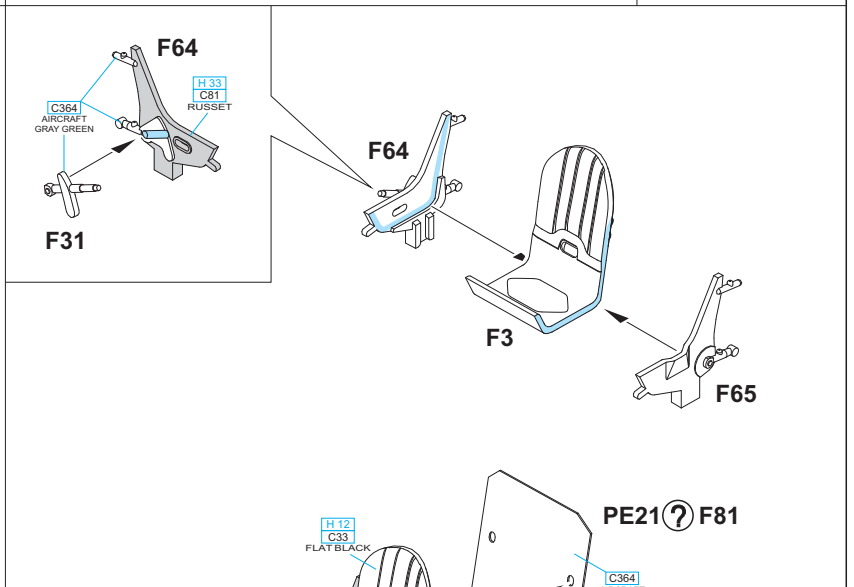
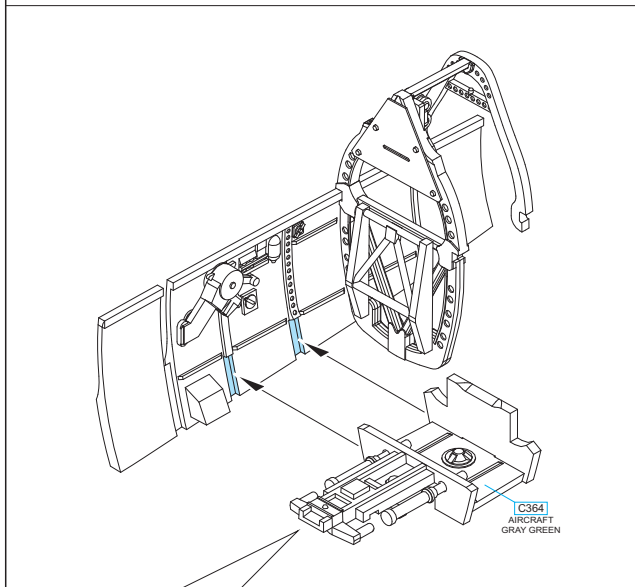
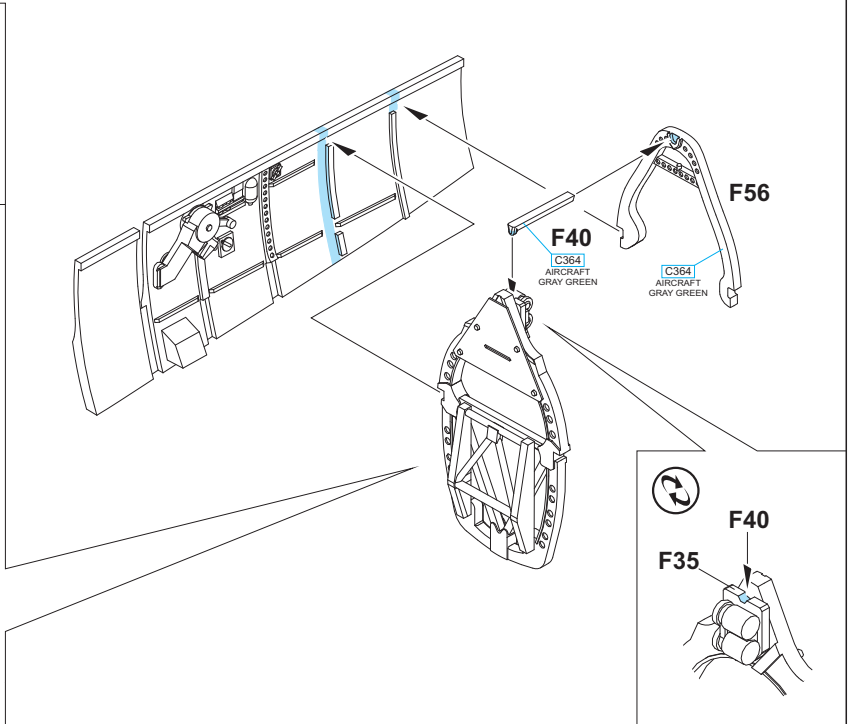
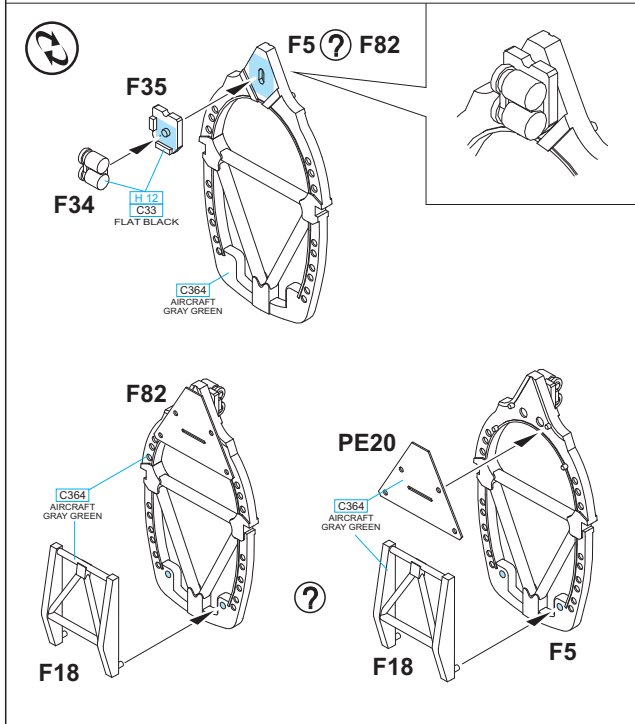
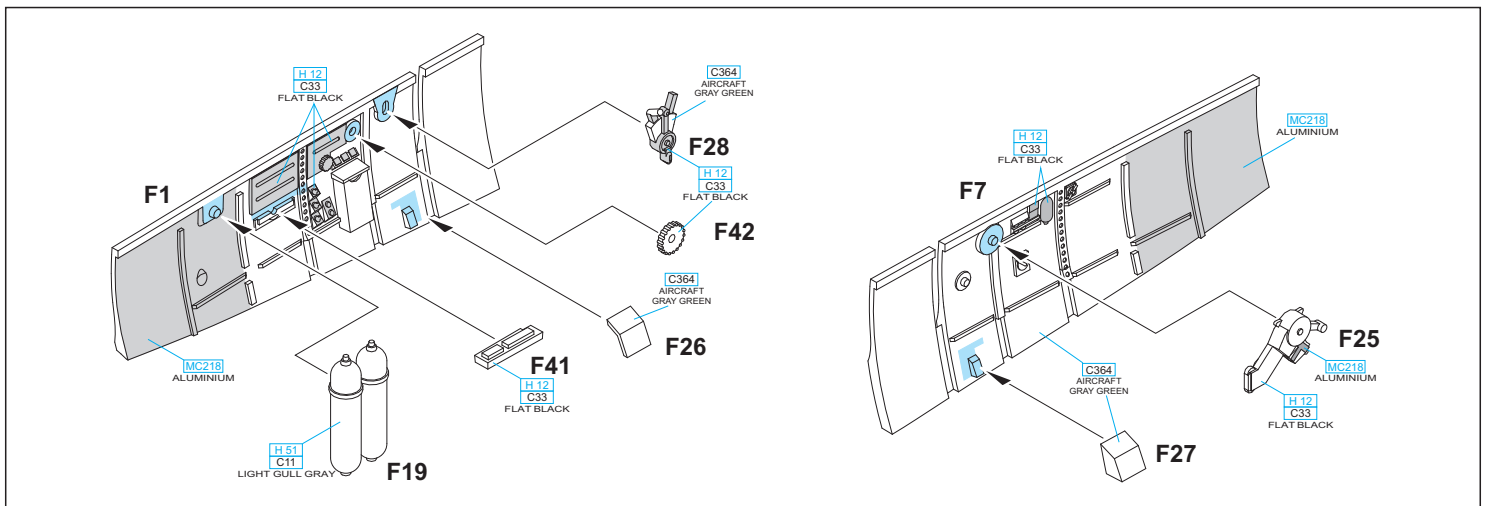

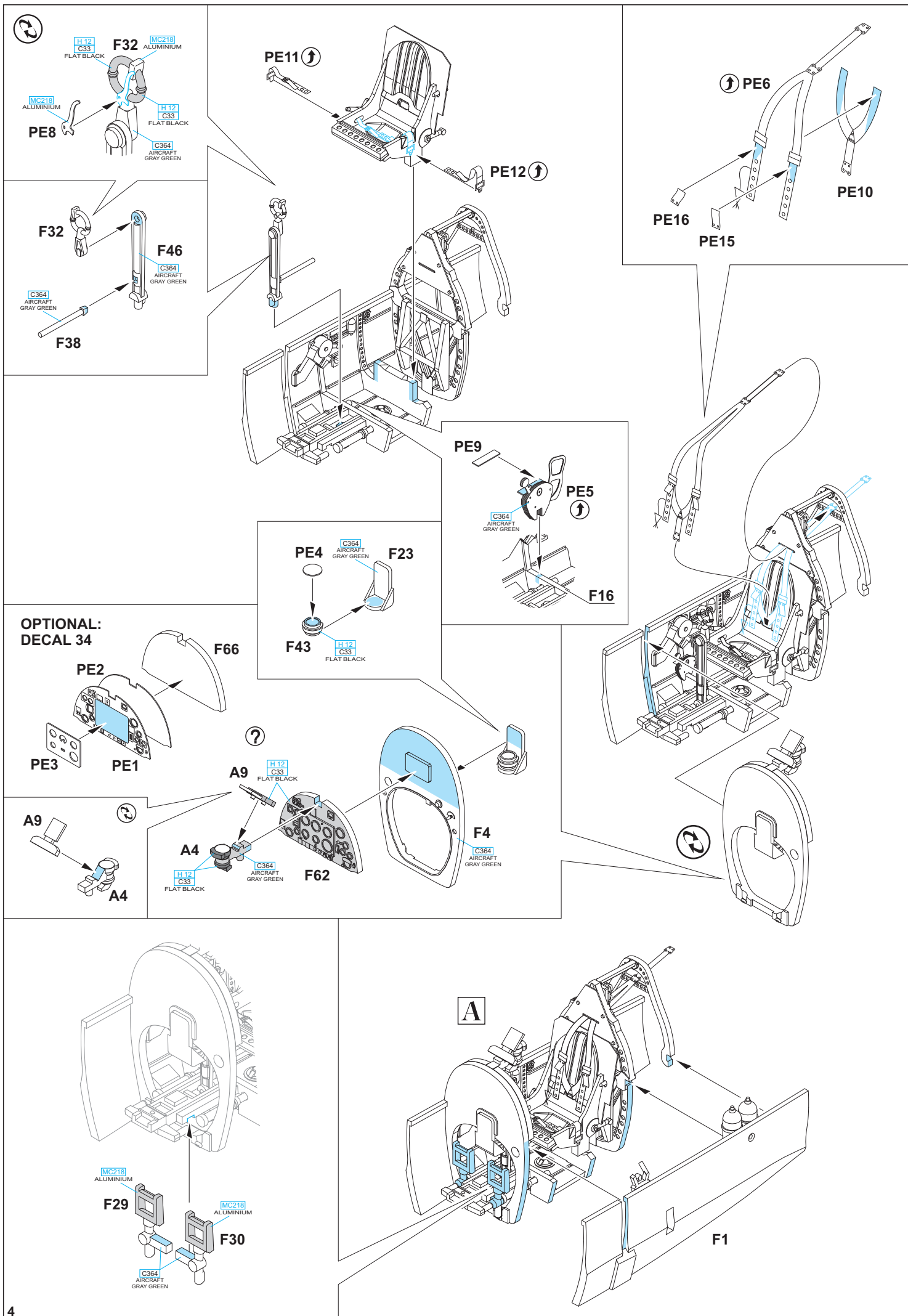

FOR CLOSED CANOPY ONLY

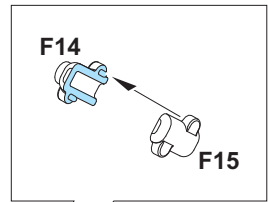
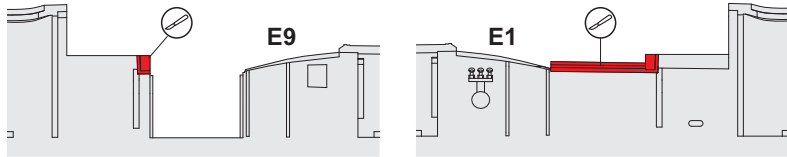

MARKINGS
A, B, C, D
ONLY

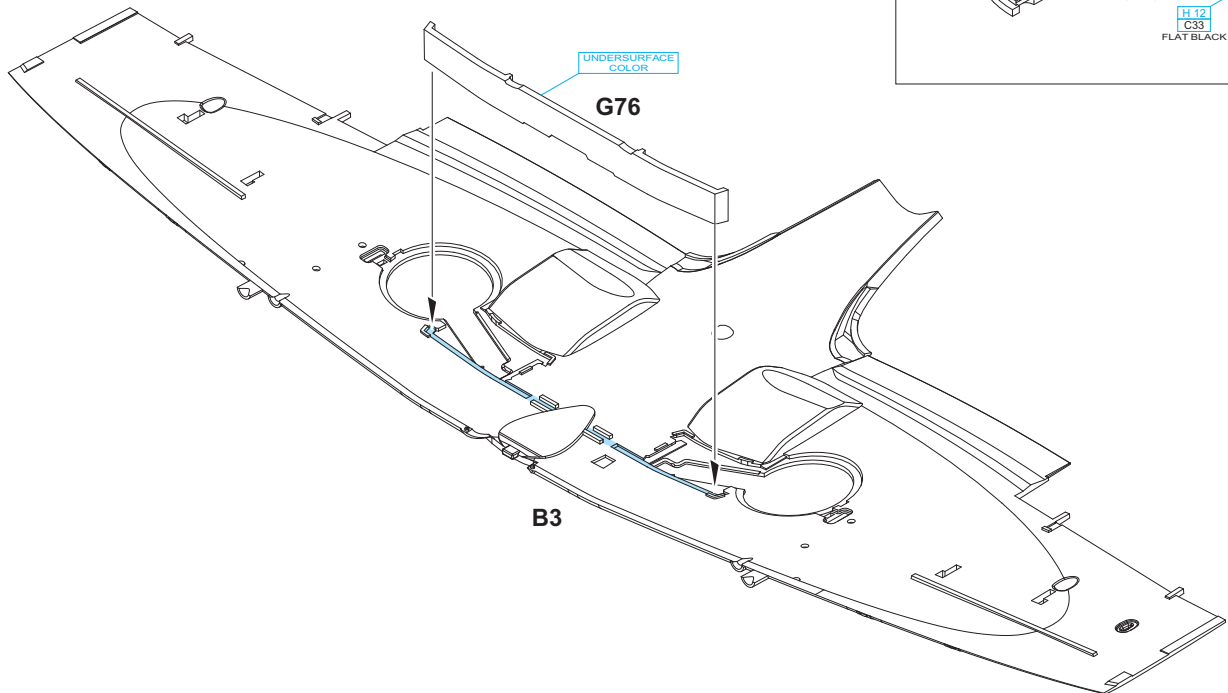
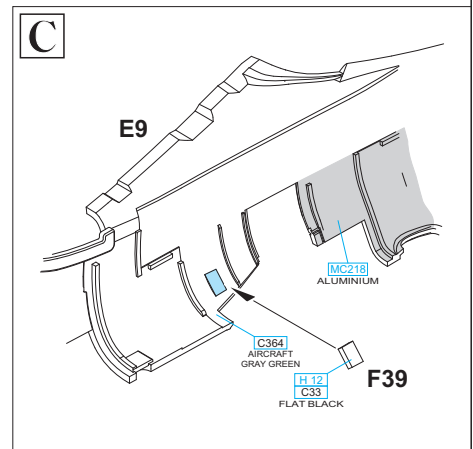
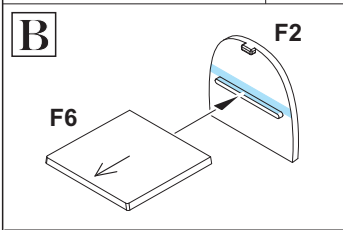
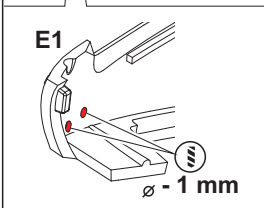
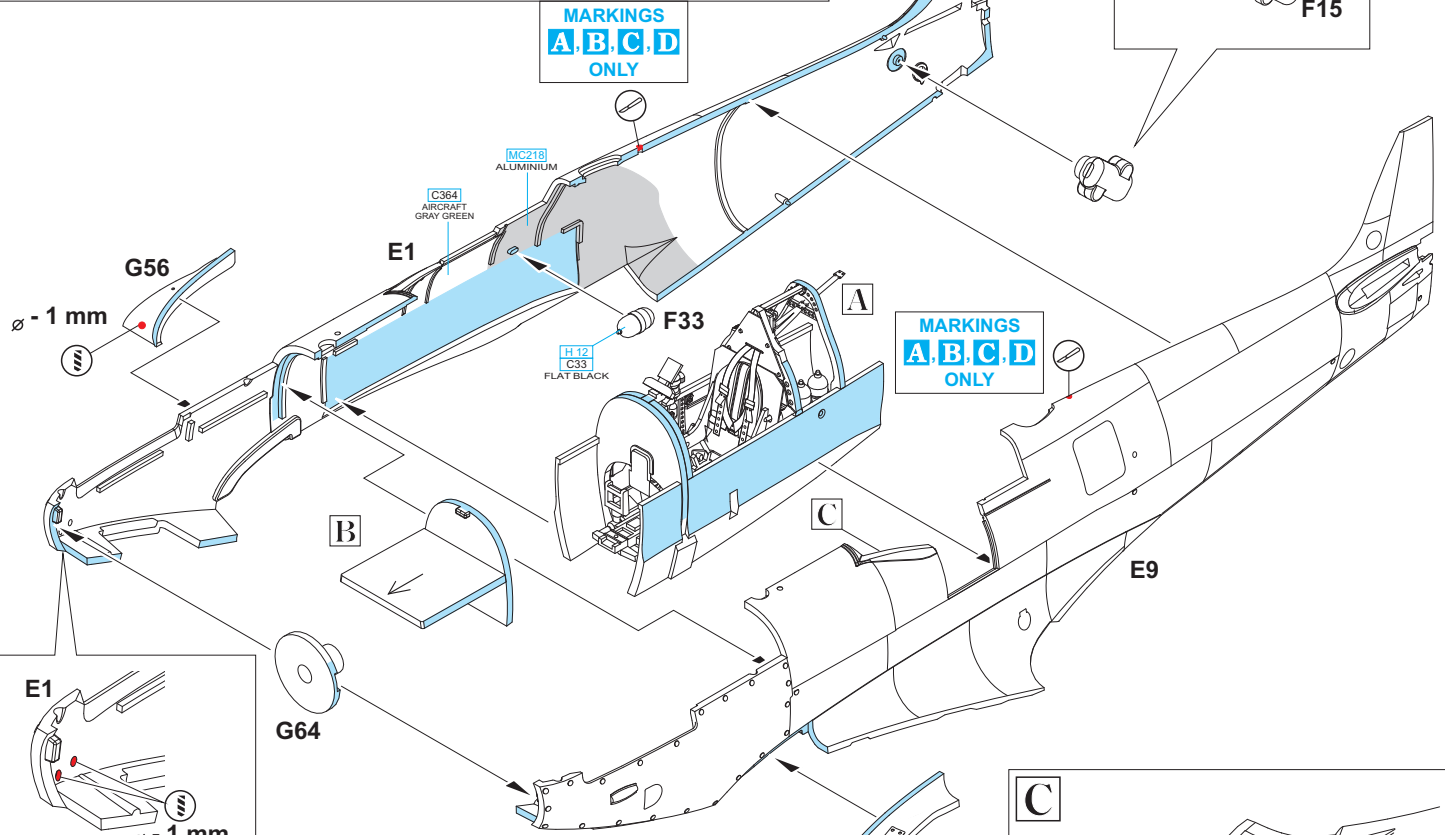

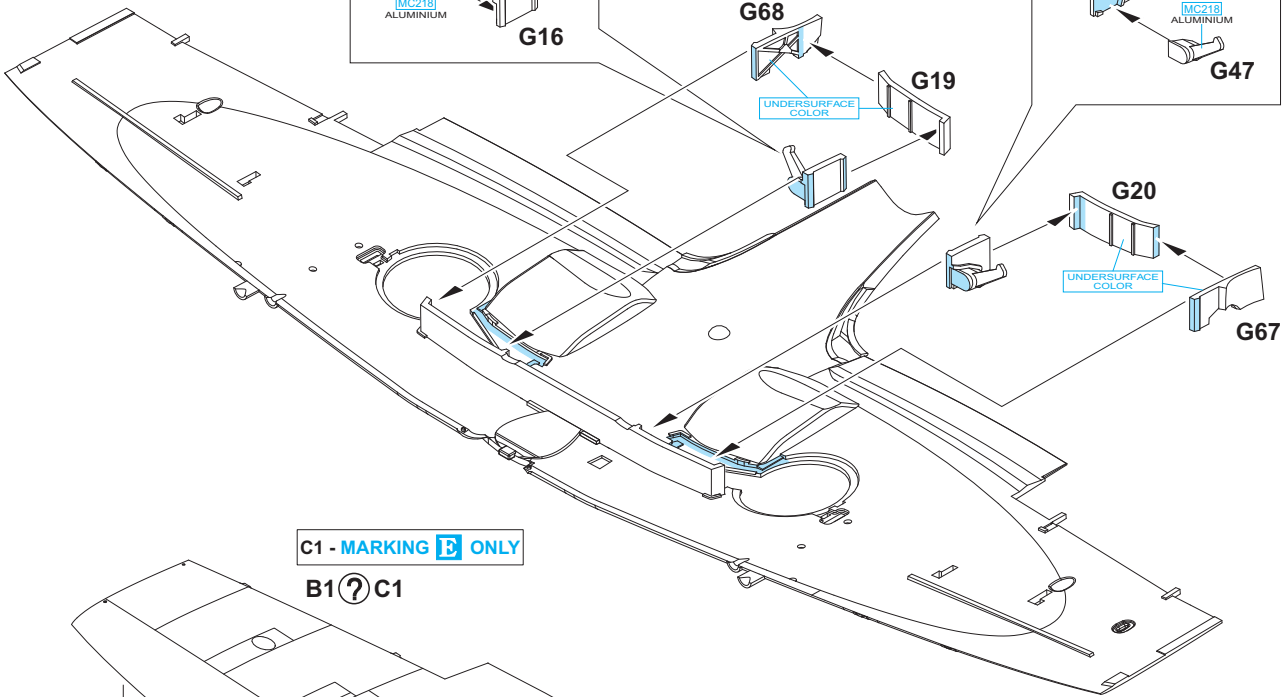
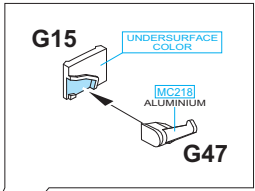
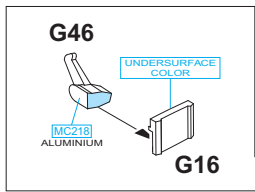

C1 - MARKING E ONLY

B1 ? C1

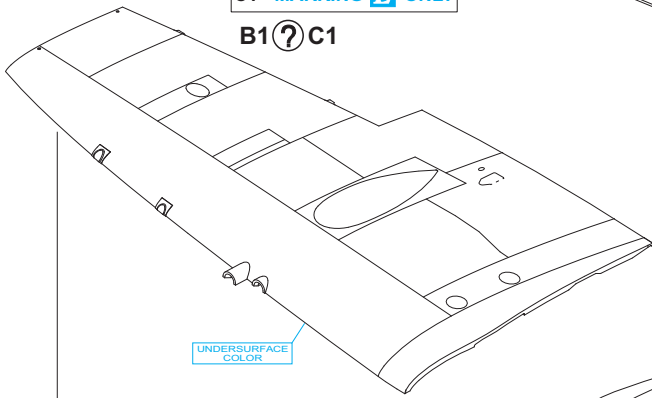

C2 - MARKING E ONLY

B2 ? C2

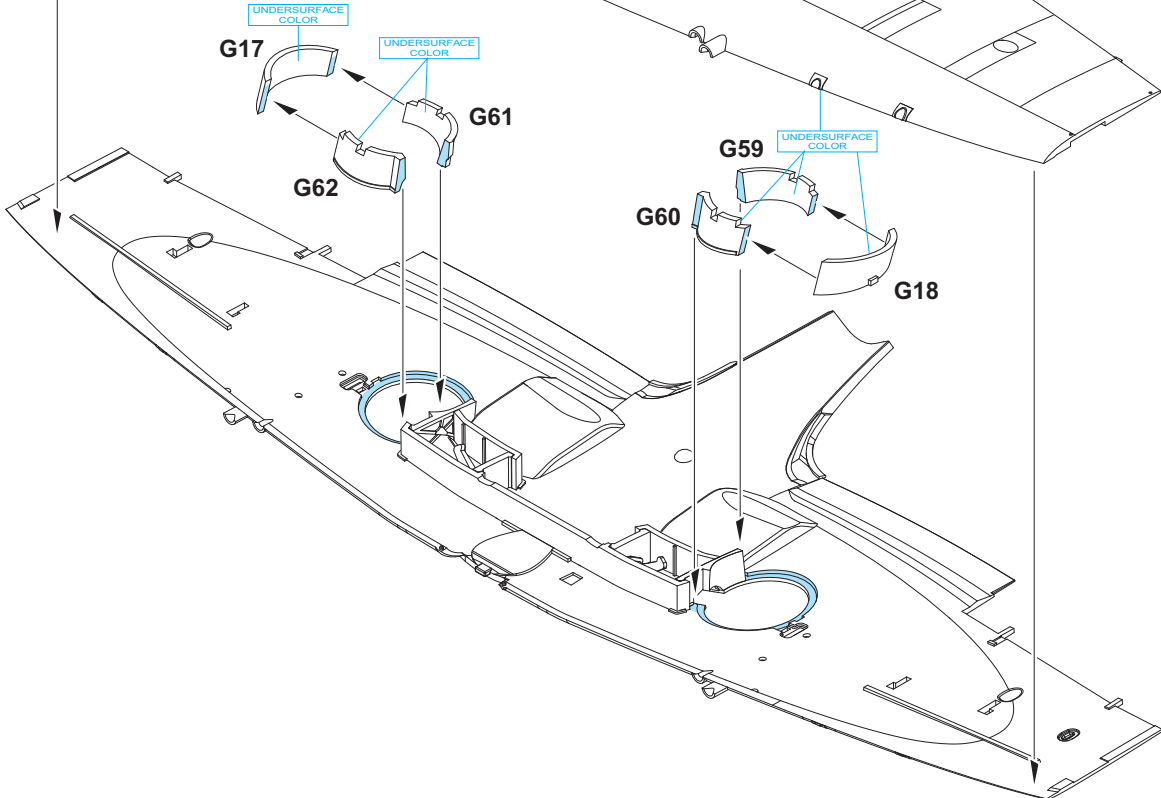
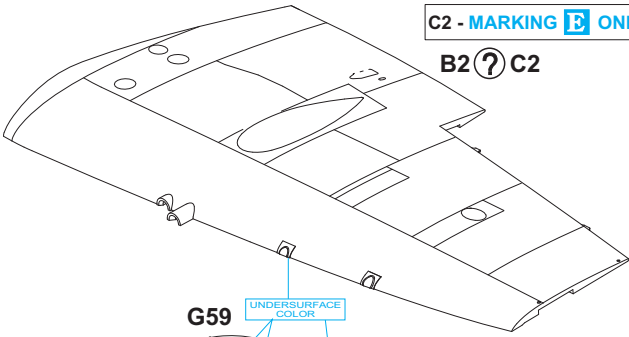

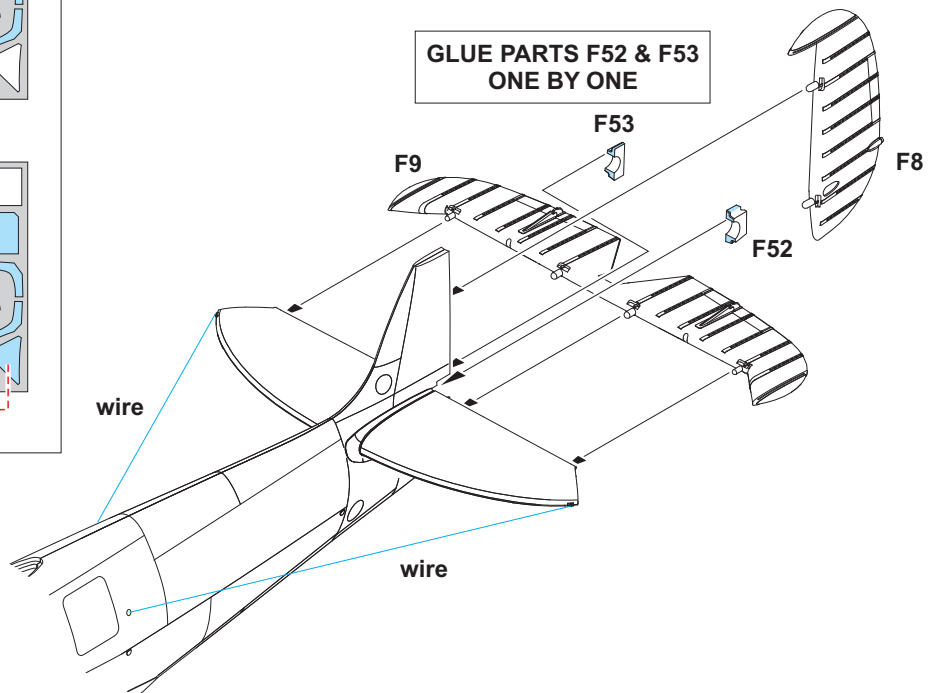
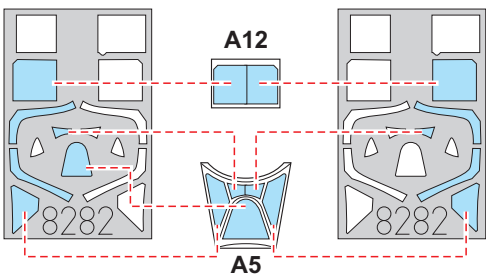
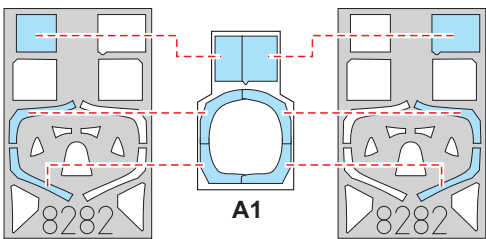
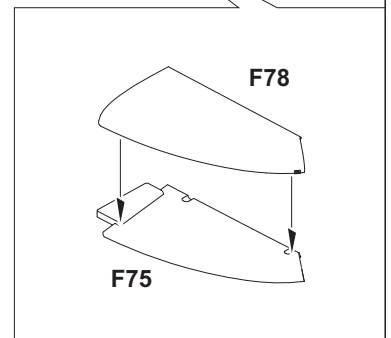
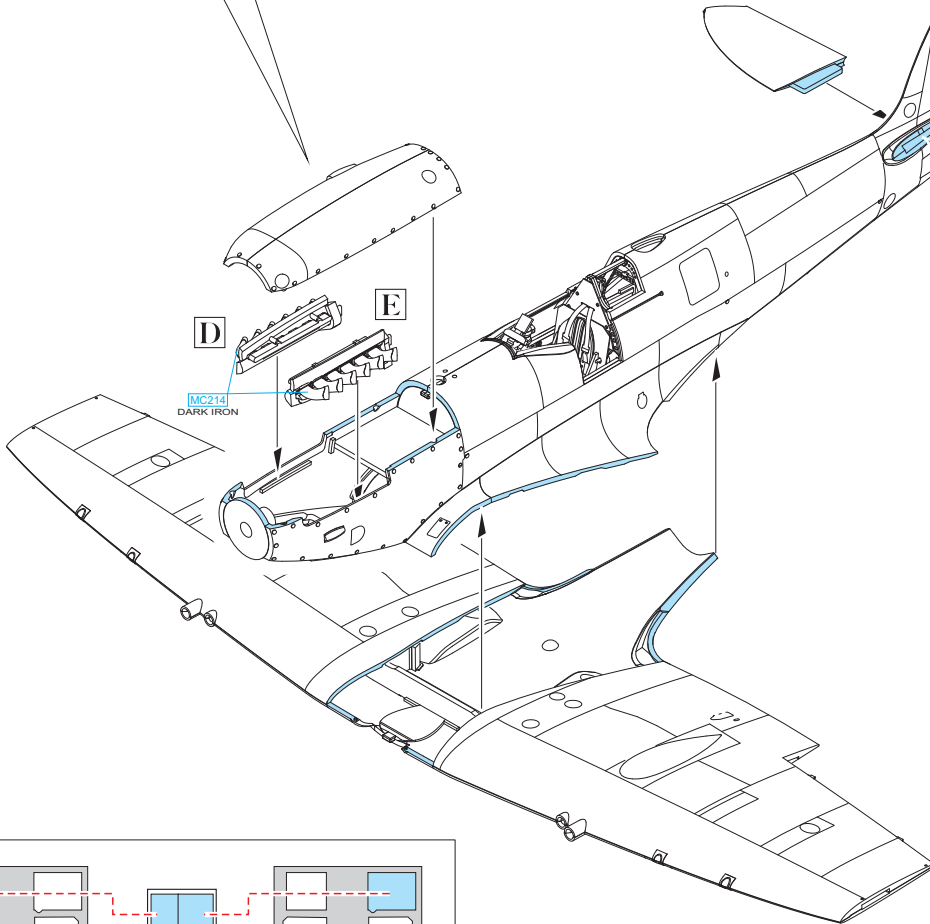
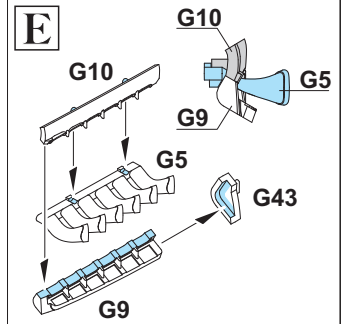
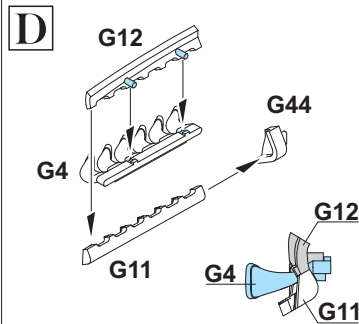
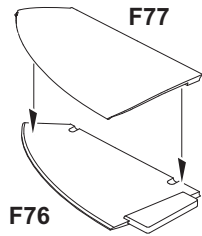
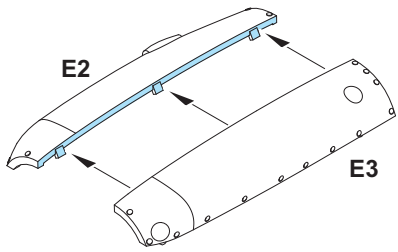

F11

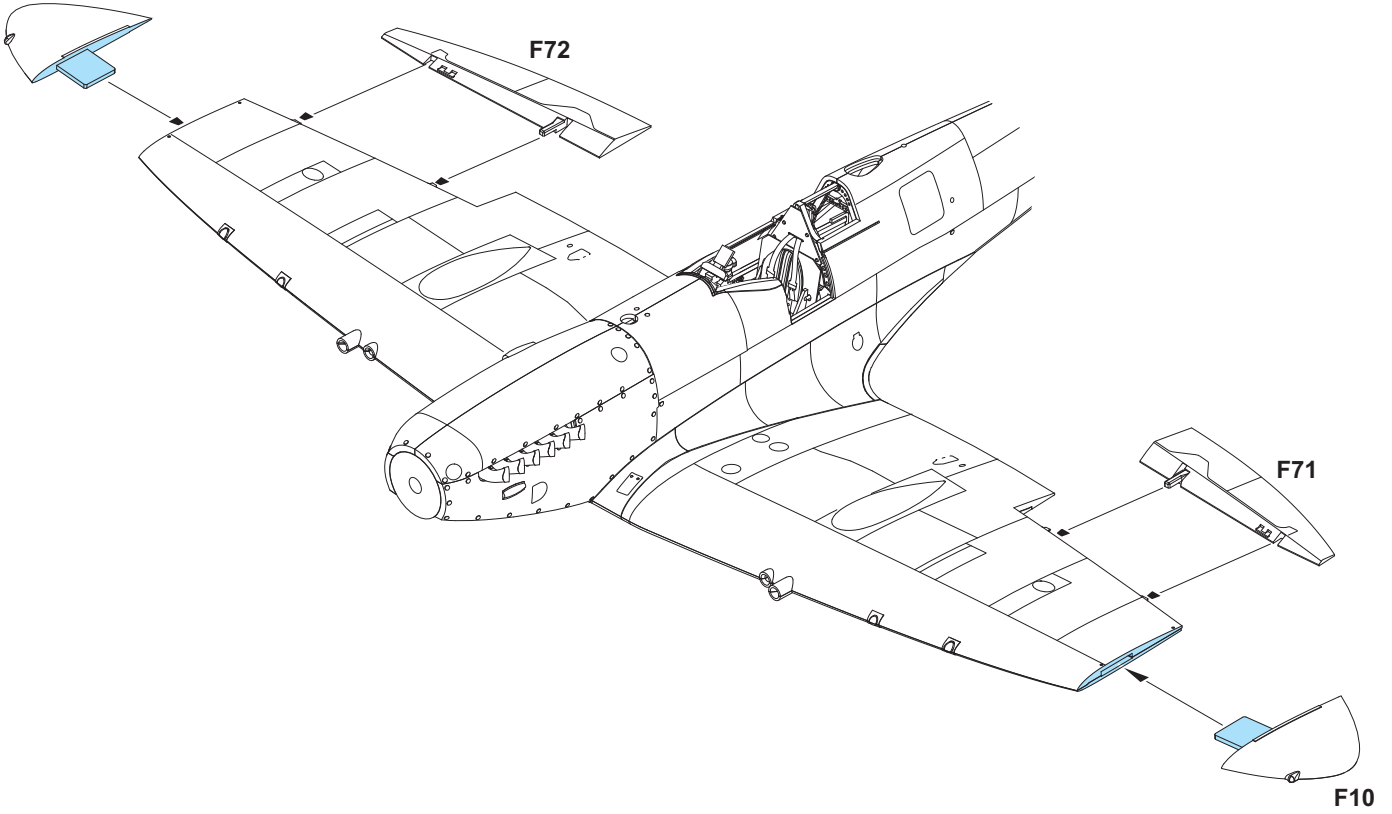

F

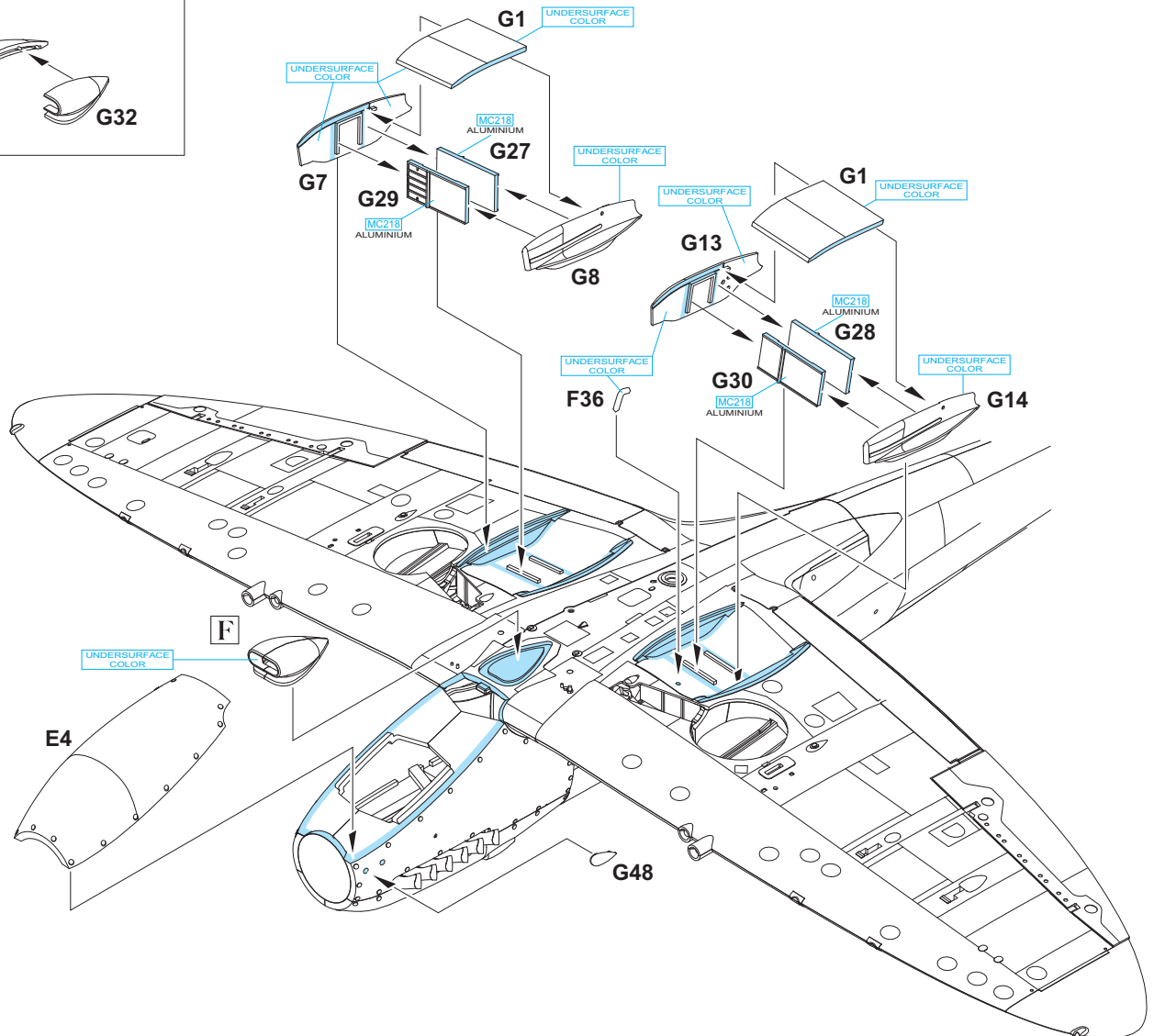
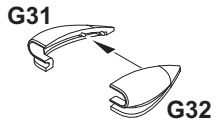

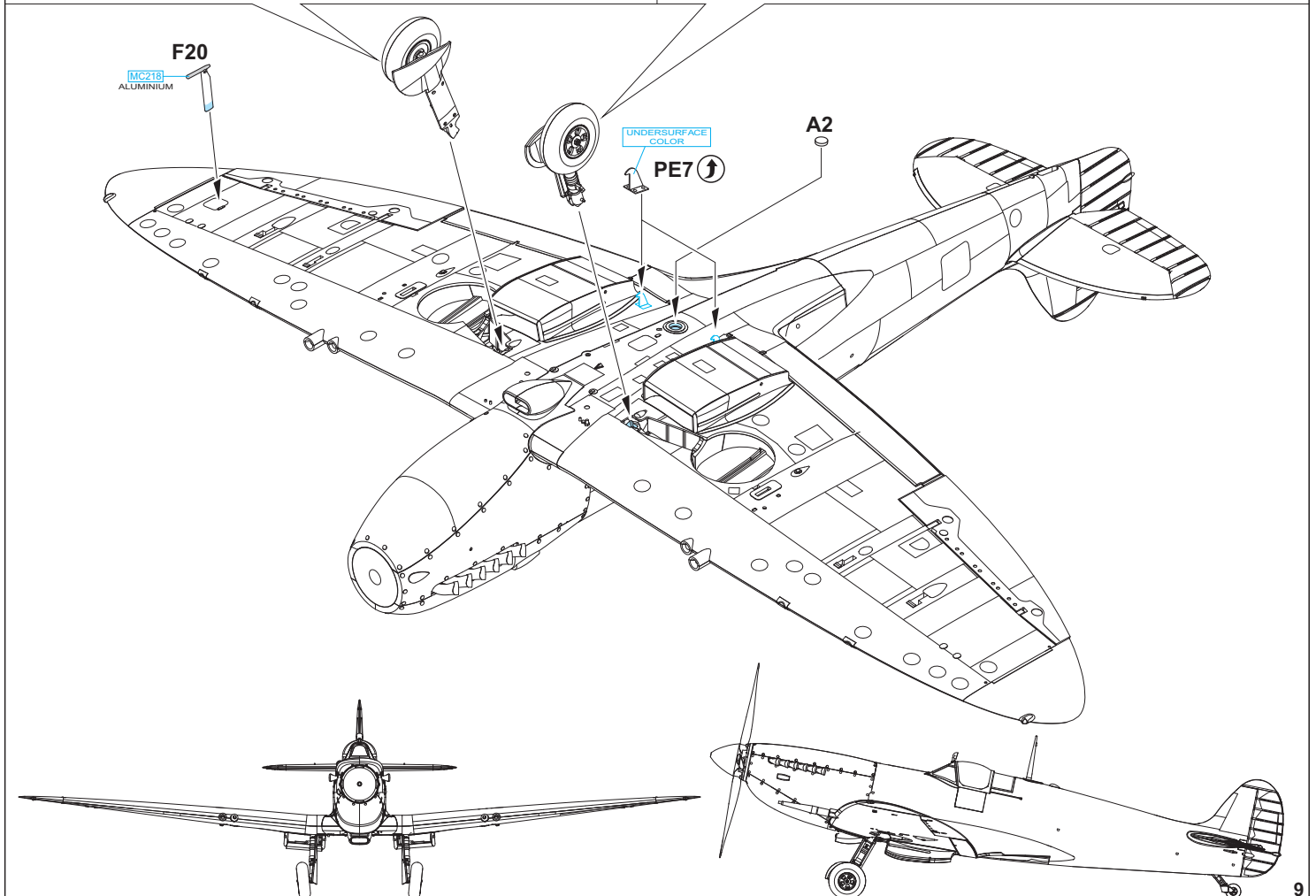
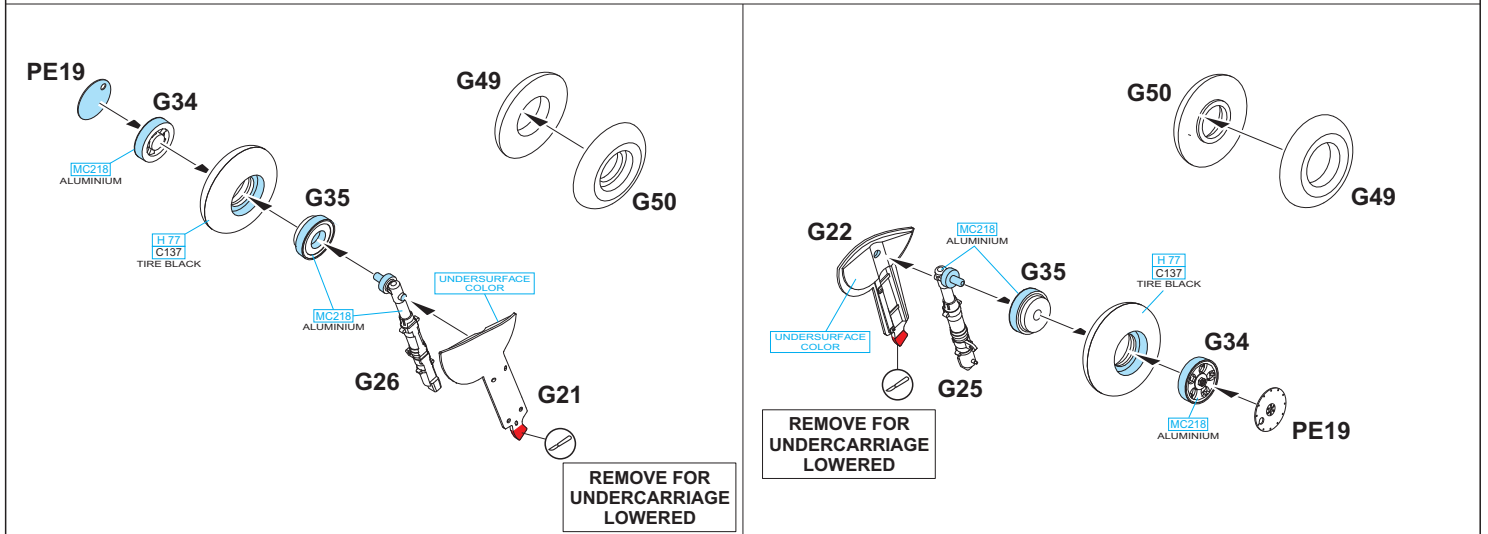
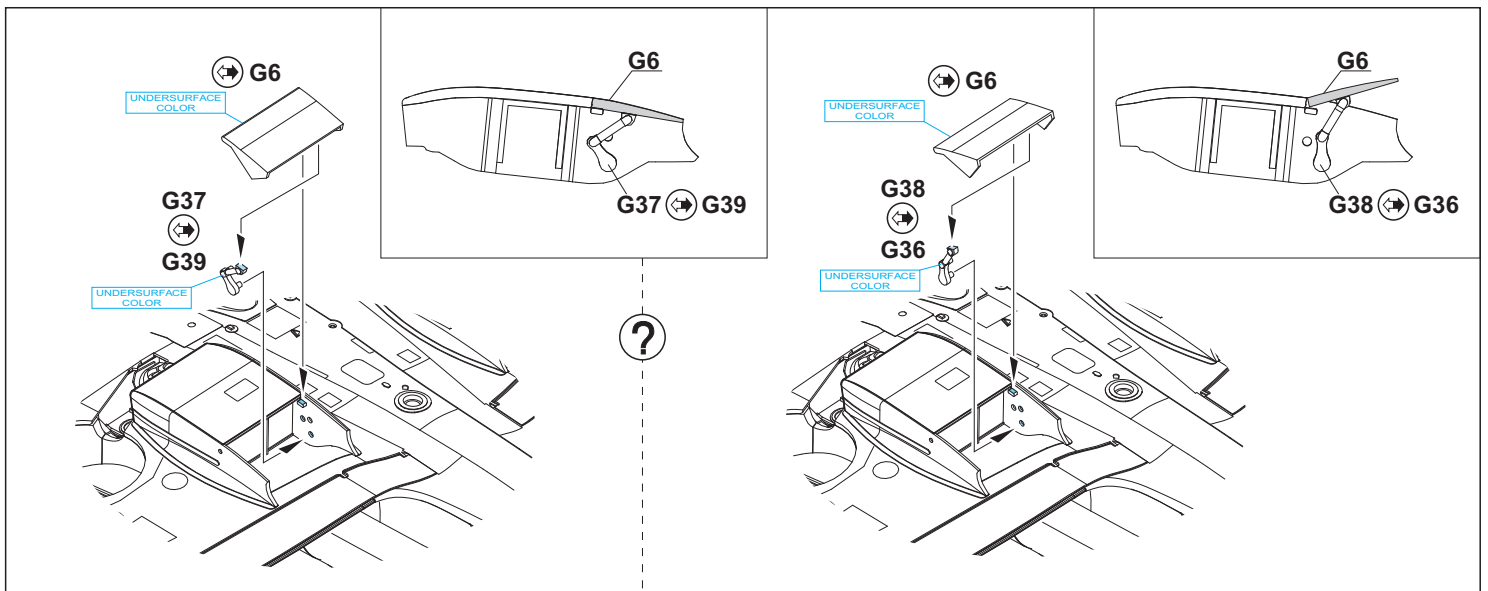

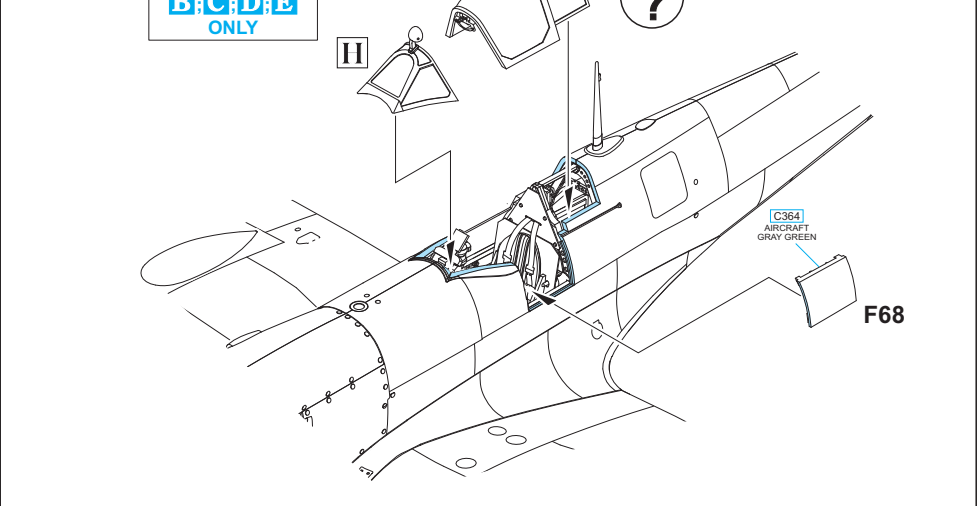
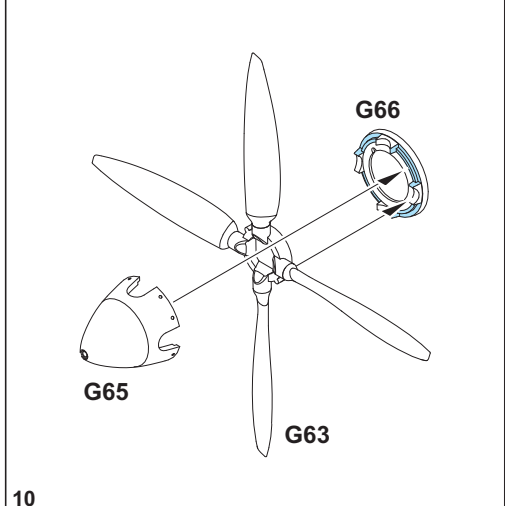
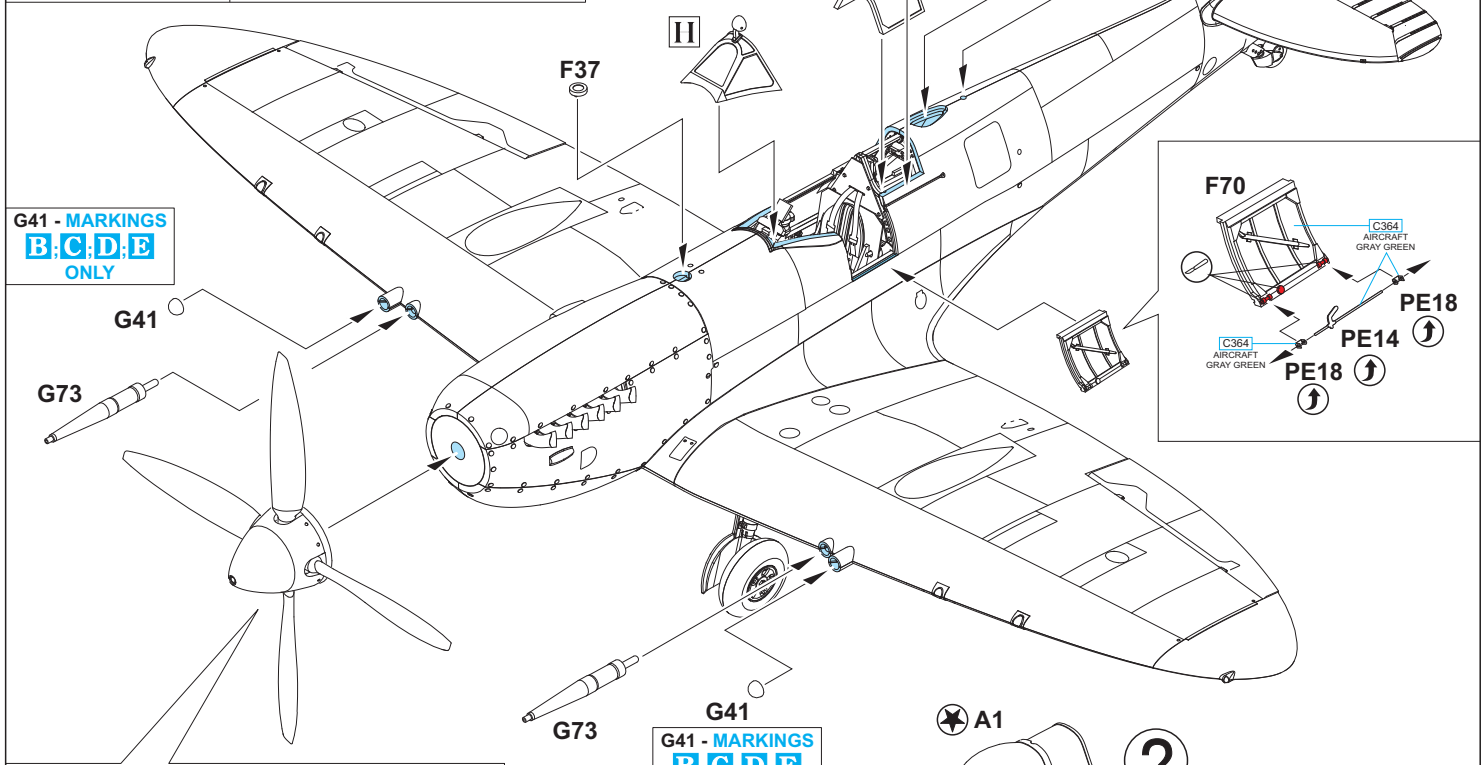
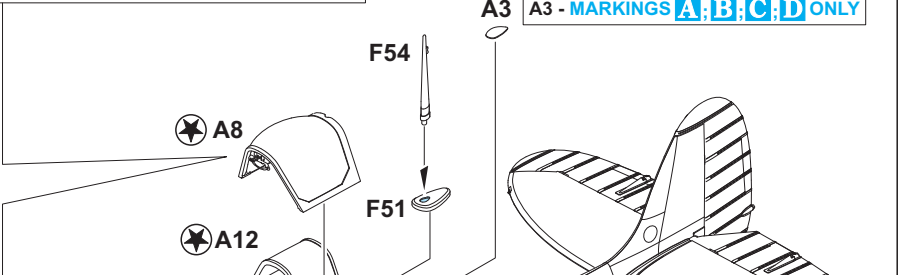
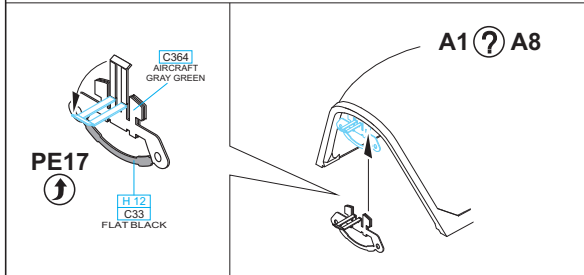
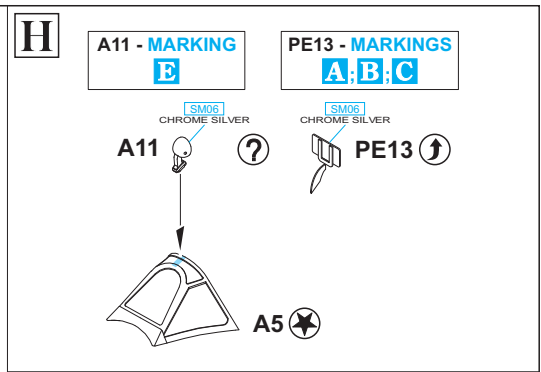
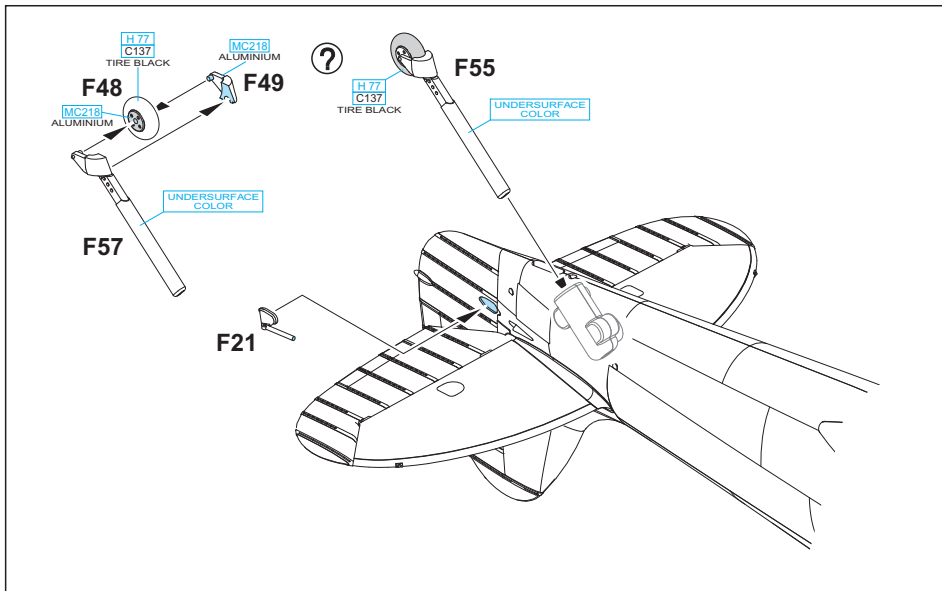

A EN315, flown by S/Ldr. Stanislav Skalski, Polish Combat Team, Northern Africa, Spring 1943

This aircraft was one of ten Spitfires flown by Polish pilots in the north African sky. The independent unit was called the Polish Combat Team. Stanislav Skalski, the famous fighter pilot with eighteen kills to his credit, acted as Squadron Leader for the Team. He was one of the pilots who flew this Spitfire. Six swastikas on the fuselage probably symbolize the victories achieved by various pilots while flying the aircraft. The desert camouflage scheme consists of Mid Stone and Dark Earth uppersides and Azure Blue undersides.

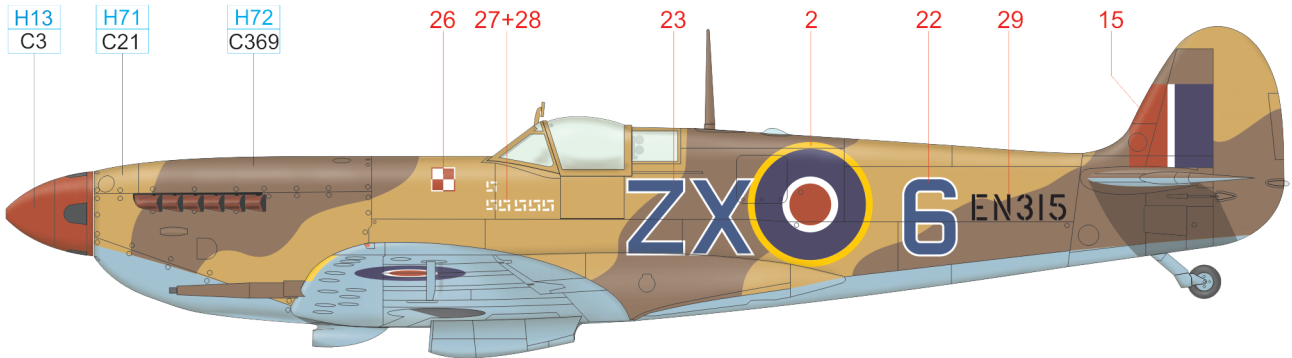

ČESKOU VERZI TEXTU NALEZNETE NA
www.eduard.com/s/8282

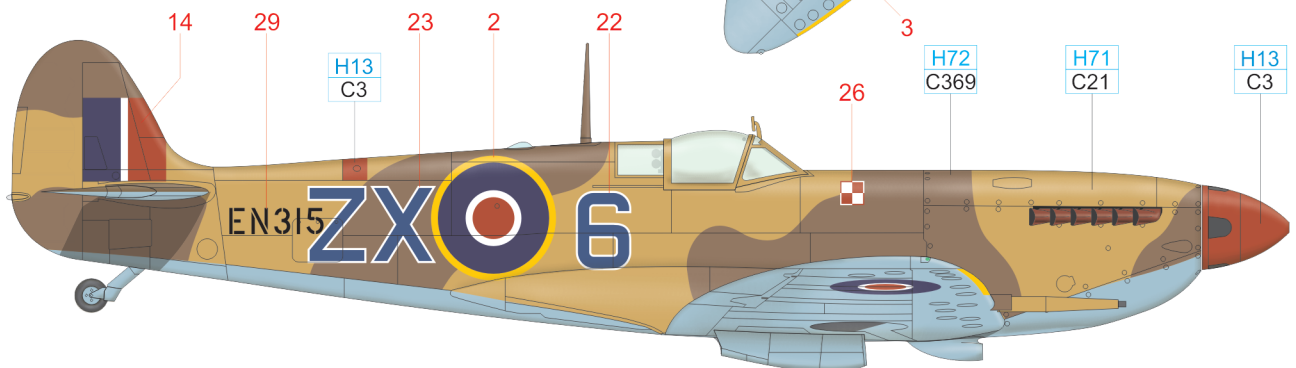
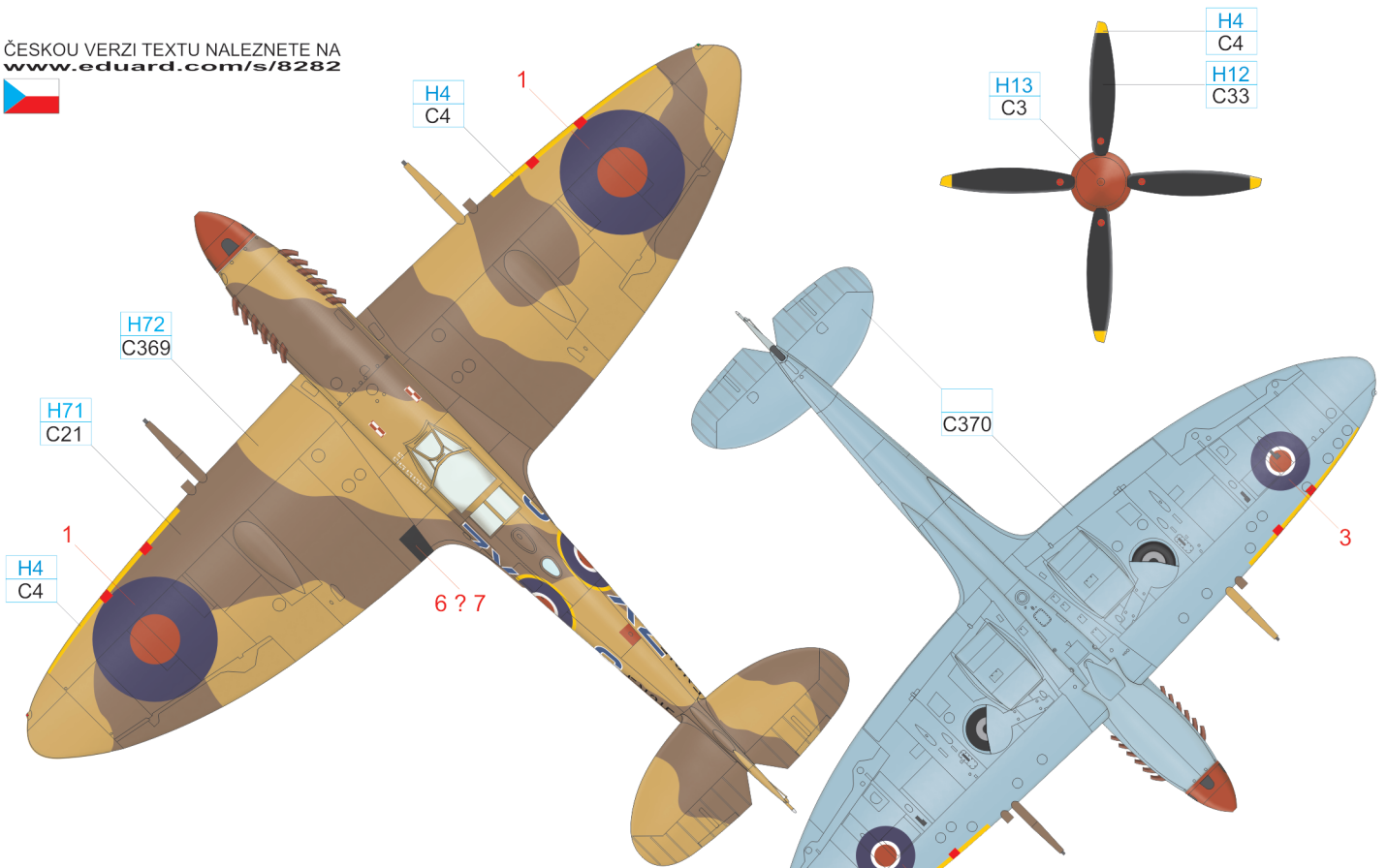

YELLOW	H4 C4	RED	H13 C3
AZURE BLUE	C370	MIDDLE STONE	H71 C21
		DARK EARTH	H72 C369
		BLACK	H12 C33

B EN133, No. 611 Squadron, Biggin Hill, Early 1943

This Spitfire flew for the first time on November 16, 1942 and its first and only known affiliation is with No. 611 Squadron, RAF. Among squadron members who were entrusted with this aircraft was Franz Ferdinand Colloredo Mansfeld, a member of Austrian nobility and a US citizen (three confirmed kills and four probables). EN133 was destroyed on March 14, 1943 during an attack on Abbeville airfield in France (operation Ramrod 188), when Spitfires clashed with Fw 190s from JG26. The pilot of EN133 – W/Cdr. James H. Slater, the CO of No. 453 Sqdn RAAF – was killed in action.

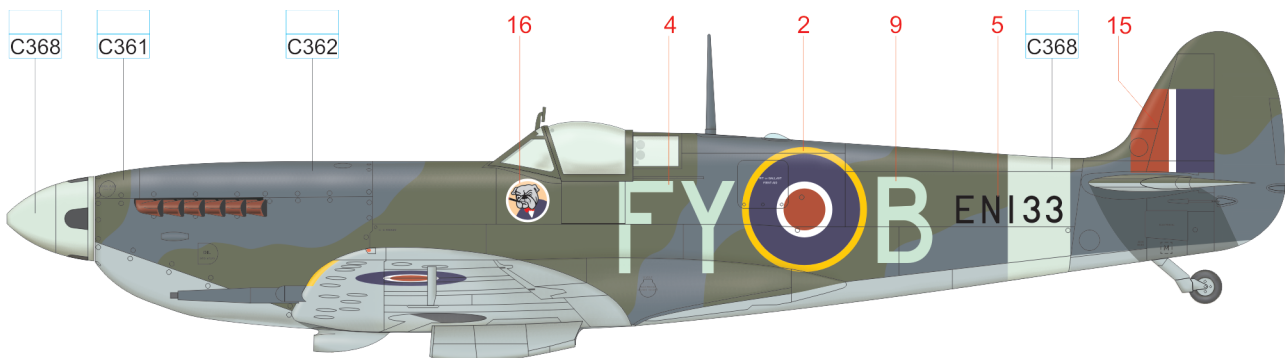

ČESKOU VERZI TEXTU NALEZNETE NA
www.eduard.com/s/8282

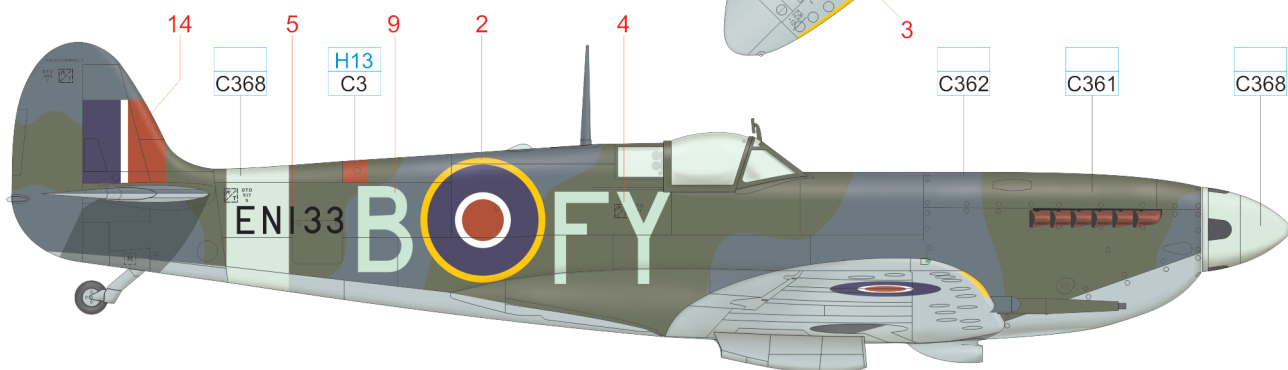
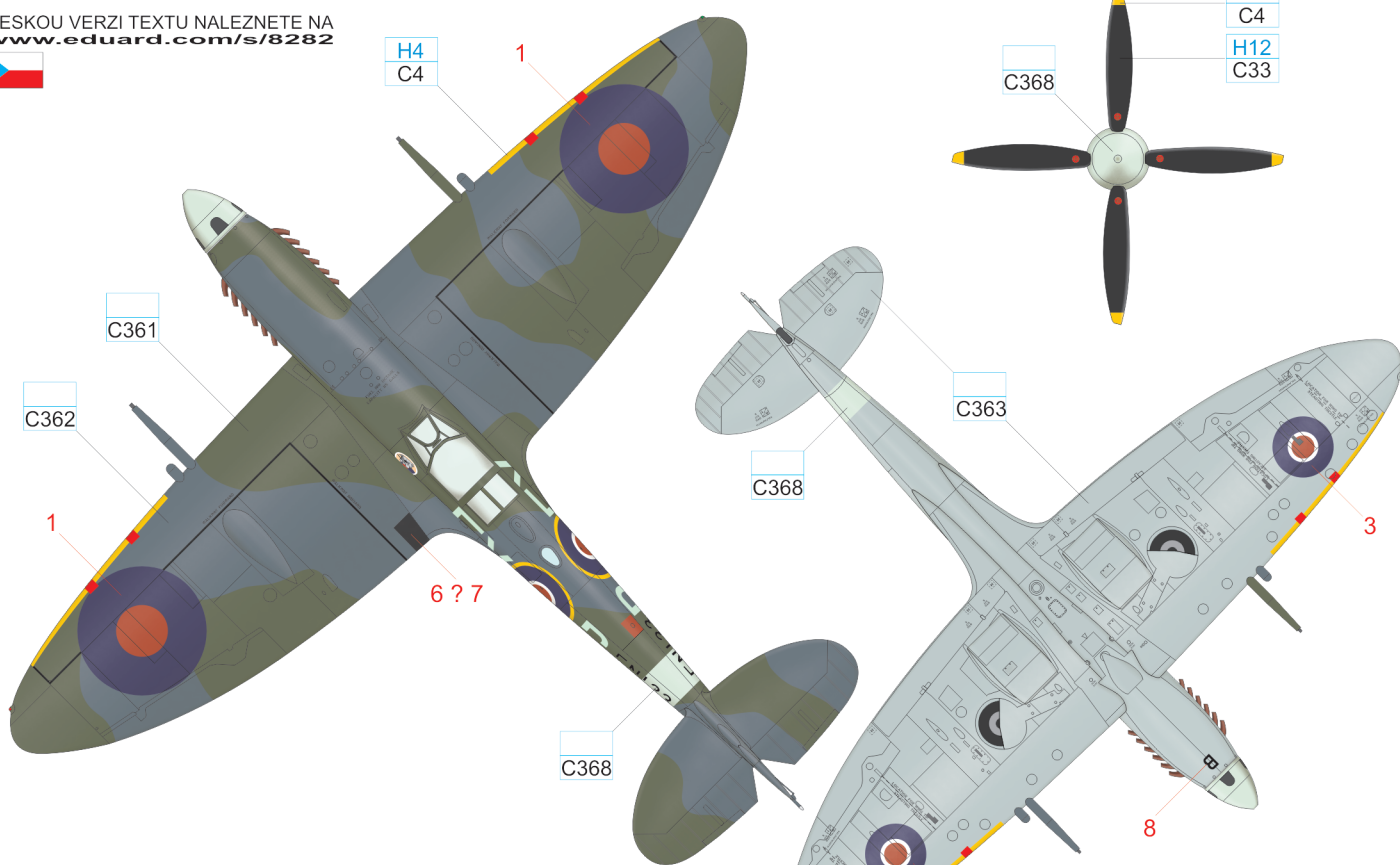

YELLOW	H4 C4	RED	H13 C3
SKY	C368	MEDIUM SEA GRAY	C363
		OCEAN GRAY	C362
		DARK GREEN	C361
		BLACK	H12 C33

C BS392, flown by S/Ldr. Bernard Dupérier, CO of No. 340 Squadron, Biggin Hill Airbase, Autumn 1942

Bernard Dupérier, the CO of No. 340 Sqdn., instructed ground personnel to paint the Donald Duck artwork on several of his aircraft. Besides this Spitfire, the artwork was applied to his Douglas DB-7 and Spitfire Mk.Vb, BM324. The CO's aircraft is marked with a pennant brushed on the fuselage and the Lorraine Cross was used by Free French squadrons. The Ocean Grey camouflage color seems to be quite light in b&w photos. Probably, a non-standard mix of paint was used while Ocean Grey was not temporarily available in sufficient quantities. Dupérier, an ace credited with seven victories, took command of No. 340 Sqdn, on April 10, 1942. That day, previous CO Phillipe de Scitiaux, was downed and captured by the enemy. Dupérier flew this Spitfire only rarely in the period from October 25 to November 7, 1942. Later on he became the CO of No. 341 Sqdn., and after the war was active in politics and supported General de Gaulle. Spitfire BS392 was used by various units, its fate being sealed on September 9, 1944. A member of No. 310 Sqdn., Sgt. Vojtech Skreka – Baudoin overran the runway during a landing maneuver and BS392 had to be written off.

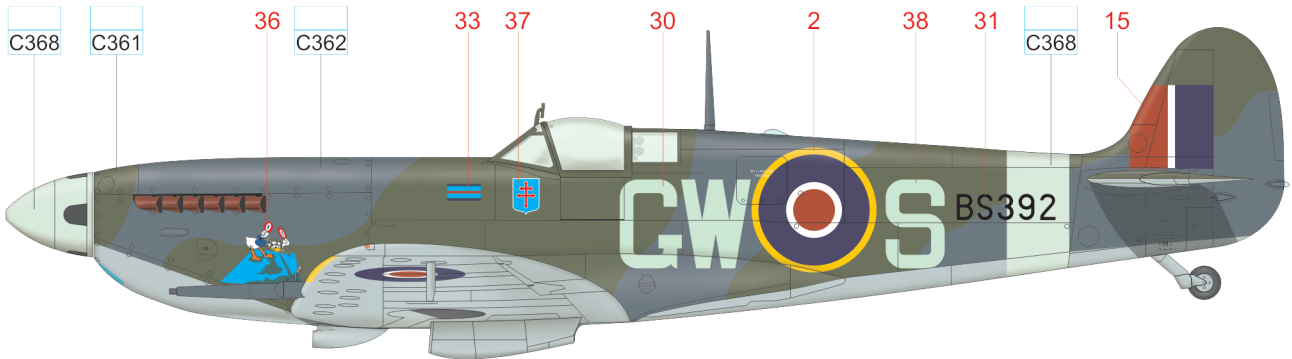

ČESKOU VERZI TEXTU NALEZNETE NA www.eduard.com/s/8282

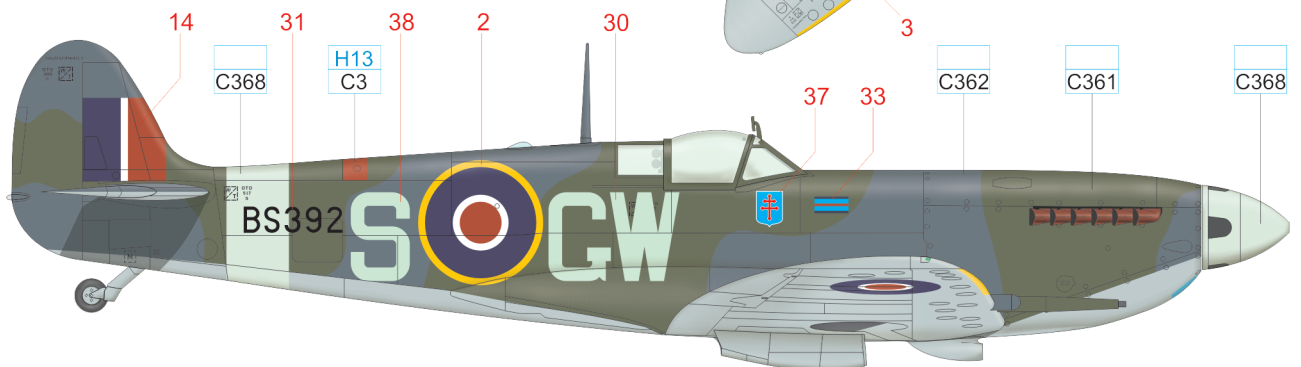
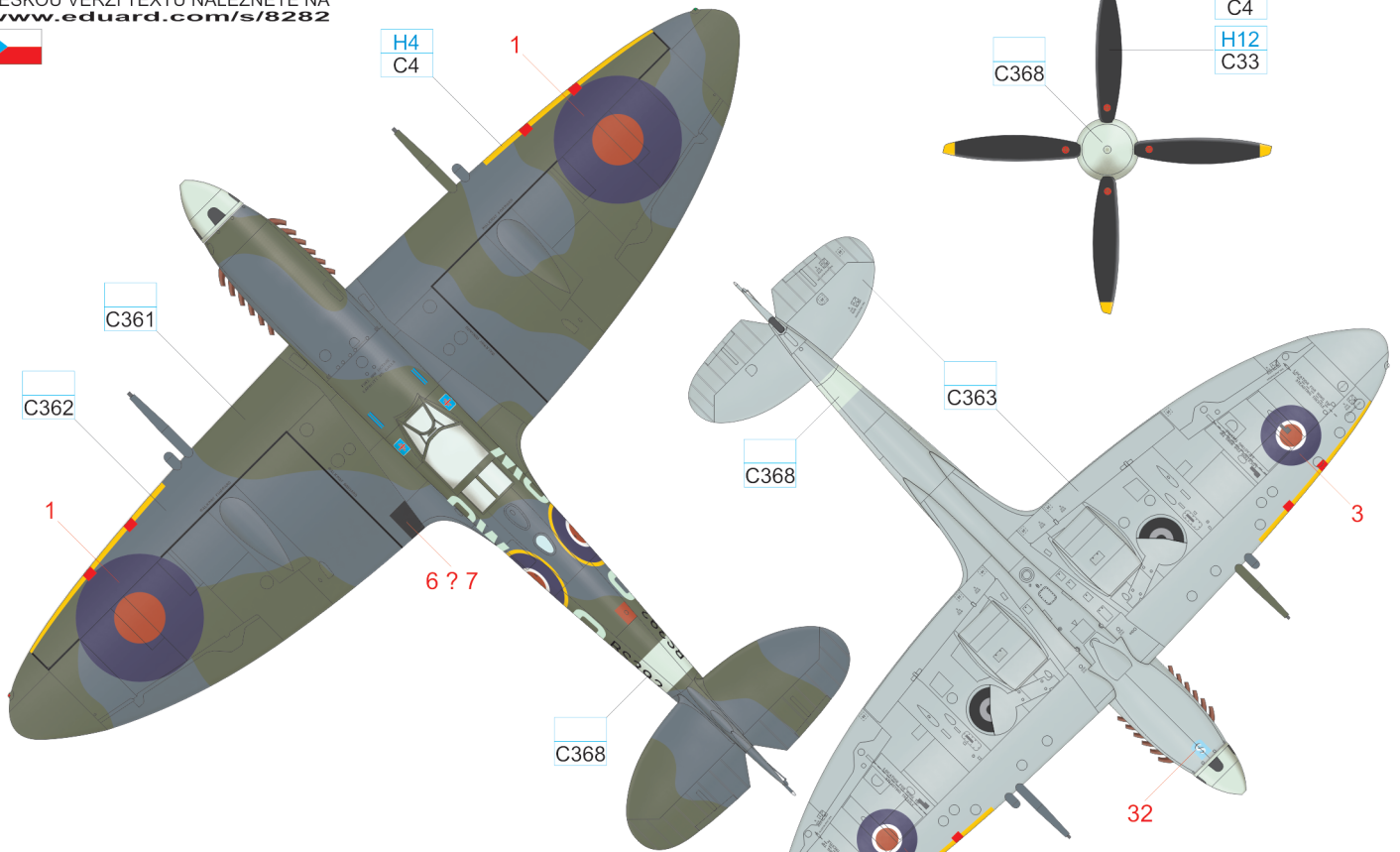

YELLOW	H4 C4	RED	H13 C3
SKY	C368	MEDIUM SEA GRAY	C363
OCEAN GRAY	C362	DARK GREEN	C361
BLACK	H12 C33		

D EN354, flown by 1st Lt. Leonard V. Helton, 52nd FG, 4th FS, La Sebala Airfield, Tunisia, June, 1943

The US Army Air Force was one of the Spitfire MK.IX operators in the Mediterranean Theatre of Operations. The 52nd Fighter Group flew Spitfires till March / April 1944 when it was re-equipped with the P-51 Mustang. The Group came to northern Africa as a part of the invading Allied forces during Operation Torch that was launched on November 8, 1942. The British camouflage is topped up with US national insignia. At least one British roundel was left on the left wing underside. The former markings were overpainted with fresh colors that seem to be darker than the rest of the camouflage. The new code letters were added then. The yellow outline of the national insignia was applied during Operation Torch to distinguish US aircraft and frequently seen in the Mediterranean during the following months.

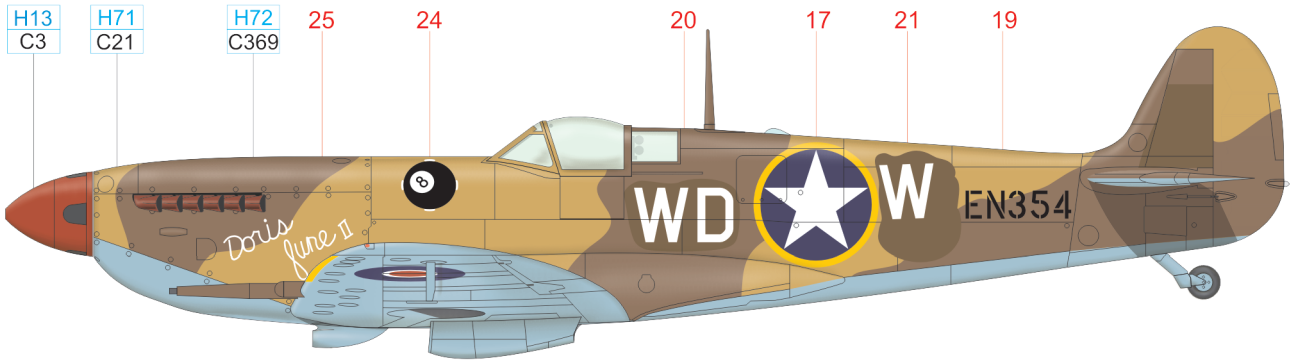

ČESKOU VERZI TEXTU NALEZNETE NA www.eduard.com/s/8282

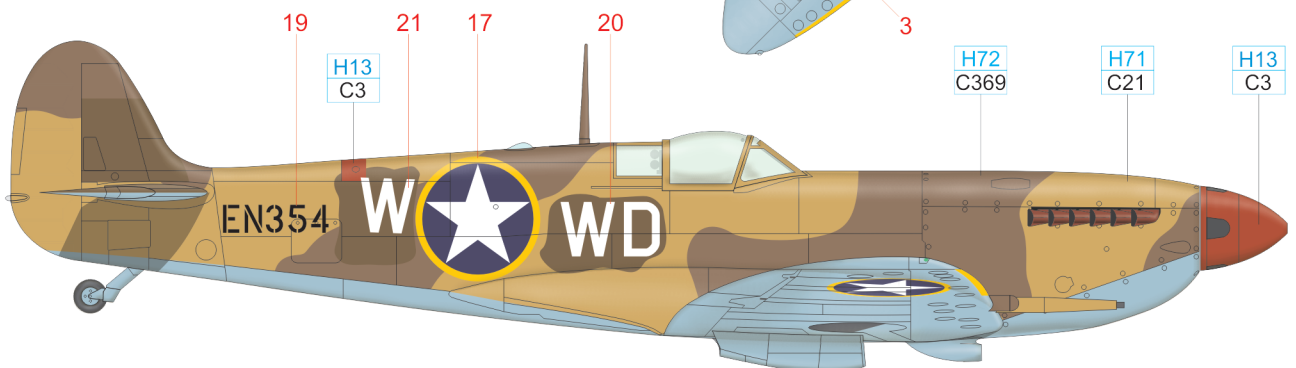
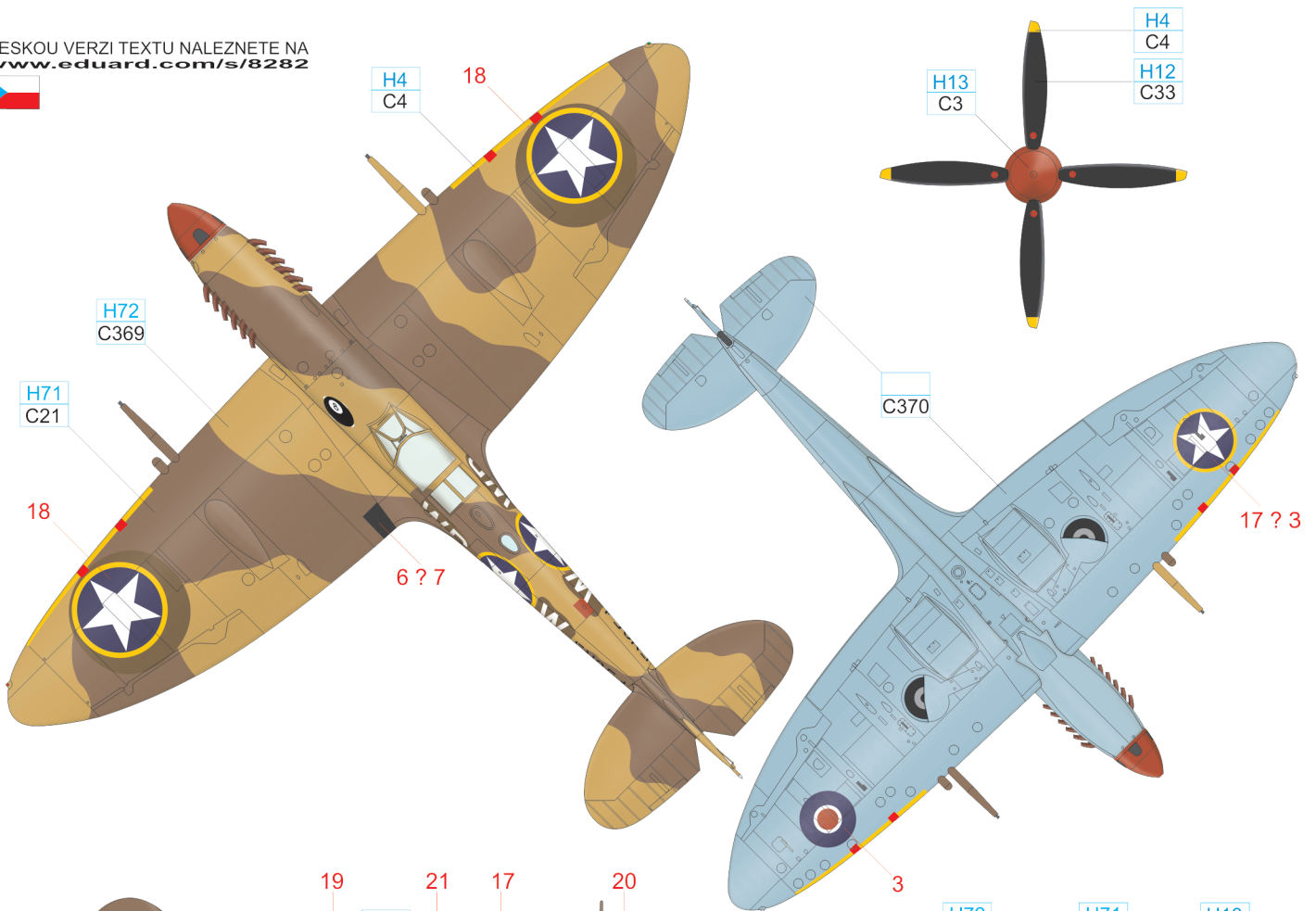

YELLOW	H4 C4	RED	H13 C3
AZURE BLUE	C370	MIDDLE STONE	H71 C21
		DARK EARTH	H72 C369
		BLACK	H12 C33

E EN568, flown by W/Cdr. Alan C. Deere, CO of Biggin Hill Wing, Biggin Hill Air Base, June, 1943

Alan C. Deere was born in Auckland, New Zealand. He entered the RAF in 1937 and fought against Nazi Germany from the outbreak of the war in France. Deere took significant part in the Battle of Britain and flew Spitfires over occupied Europe. From June 1943, he led Biggin Hill Wing for six months and added four more kills to his eighteen confirmed victories during this period. Late in the war, he was appointed to various staff functions, except D-Day, when he led a Free French wing. He continued in the RAF in the postwar years. Al Deere, as a wing commander, had a right to paint individual code letters on his personal aircraft. His command role was symbolized by the pennant on the fuselage. The serial number was partially overpainted on both sides of the tail.

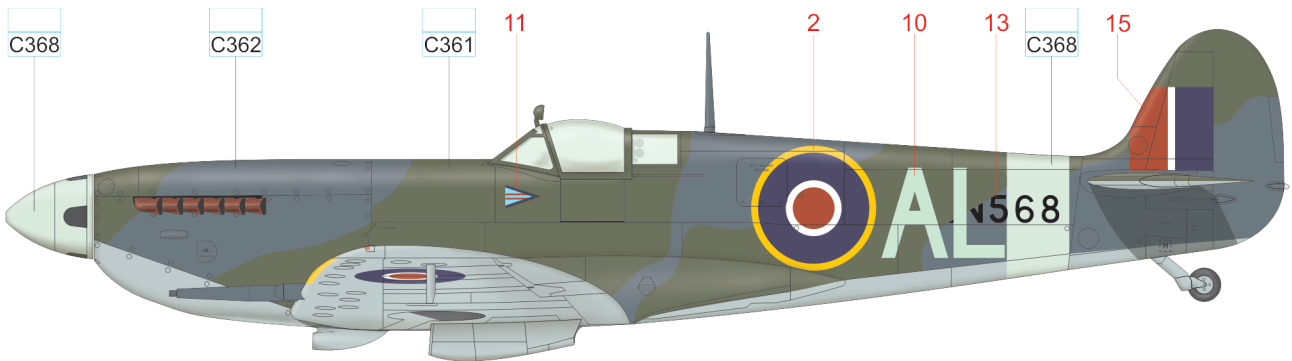

ČESKOU VERZI TEXTU NALEZNETE NA www.eduard.com/s/8282

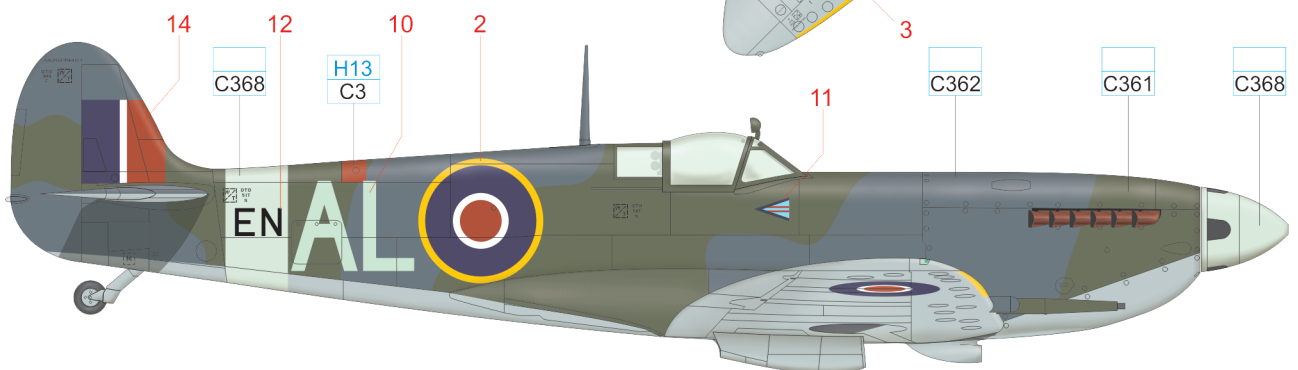
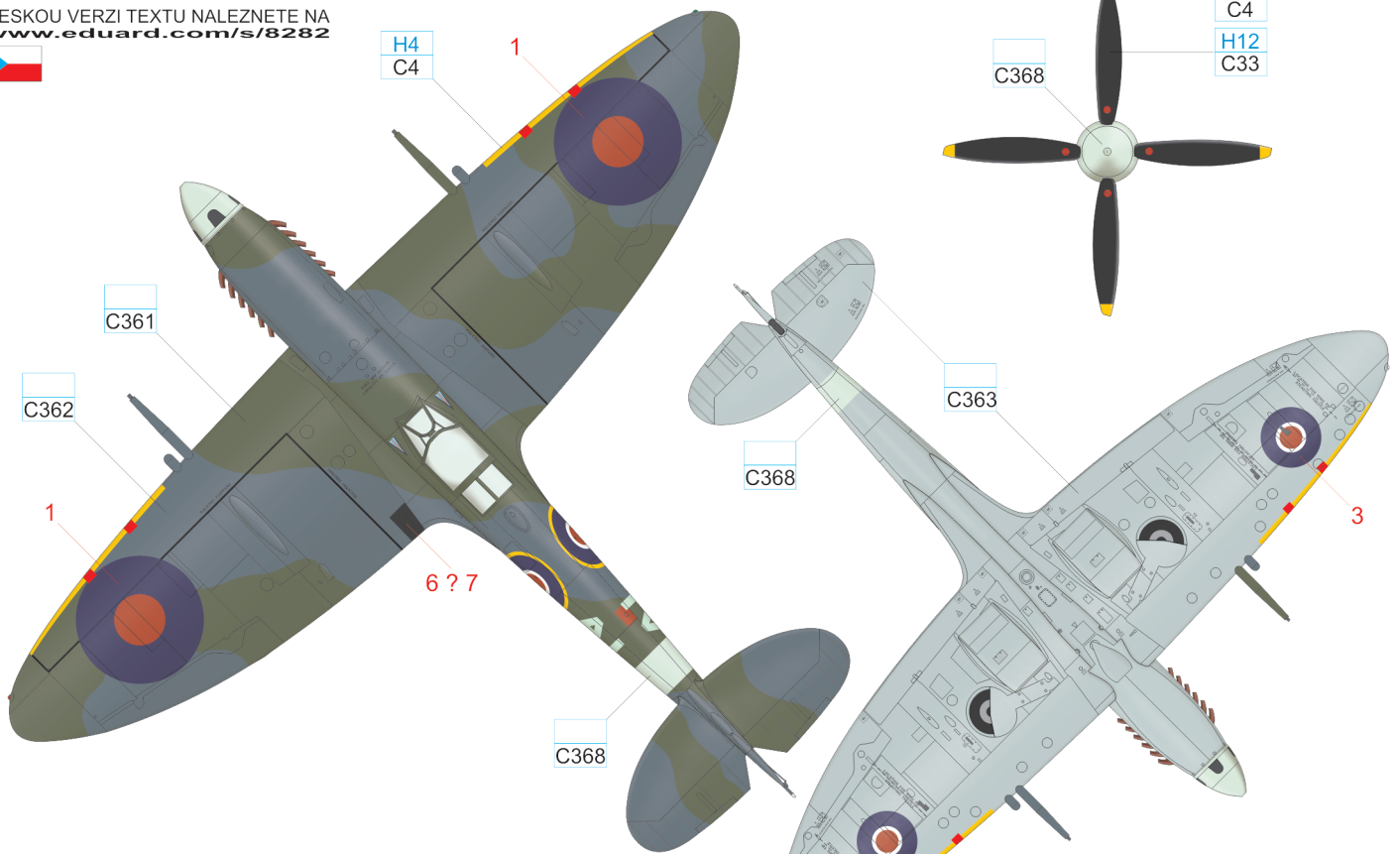

YELLOW	H4 C4	RED	H13 C3
SKY	C368	MEDIUM SEA GRAY	C363
		OCEAN GRAY	C362
		DARK GREEN	C361
		BLACK	H12 C33

