

Fw 190D-9

eduard

1/48 Scale Plastic Model Kit

WEEKEND
edition



item # 84102

The Fw 190 was the best what was available to the Luftwaffe during the second half of the World War II. It soldiered in various modifications and the “long nose” versions powered by in-line engine emerged as the top of the development line.

To meet the 1938 specification issued by the Technisches Amt, RLM, the development team led by Kurt Tank prepared new fighter, but ran into several difficulties, which were addressed continually during the process of the development. The first prototype of the new Fw 190 took to the air on June 1, 1939 and after a series of improvements and after some quite radical changes, the development culminated during the fall of 1940, when twenty-eight pre-series Fw 190A-0 were built. Six of these were retained by the test unit Erprobungsstaffel 190 at Rechlin, tasked with service trials, which revealed a wide range of flaws. After a series of some fifty modifications, the RLM gave the go ahead for the Fw 190 to be taken into inventory of the Luftwaffe.

Into combat

During June 1941, the Luftwaffe accepted the first of 100 ordered Fw 190A-1s, armed with four 7.9 mm MG 17 machine guns. The II./JG 26 was completely equipped with the type and operating on the Western Front by September 1941 they changed the game, as the new fighter was superior not only to the Hurricanes, but also to the Spitfires. During November of the same year the production of the next version Fw 190A-2 commenced. The new variant was powered by a BMW 801C-2 engine and armed with two 7.9 mm MG 17s and two MG 151s of 20 mm caliber in the wings. Part of this series received an additional pair of 20 mm MG FFs, thus attaining an armament standard of later types. A significant advancement to the design came in the spring of 1942, when the BMW 801D-2 engine became available. It's installation allowed new Fw 190A-3 variant to be entered and in July 1942 the development continued with the improved Fw 190A-4. Both were armed with what was to become the standard armament for future Fw 190s; i.e. two fuselage mounted MG 17s, two wing mounted MG 151 cannons, and two MG FF cannons, placed inboard of the wheel wells.

Mass production begins

During 1942 the production of Fw 190 had intensified, and another production facility was set up at Fieseler, where the “Würgers”, as the Fw 190s were nicknamed, were built under license. Thanks to this step and to other measures, production rose in 1942 to 1,878 units, comparing quite amazingly to just 224 aircraft in 1941. Large-scale production of the Fw 190A-5 was initiated in April 1943 with an identical wing to the A-4 variant, but with a nose extension that would become standard on all subsequent Fw 190A versions up to the A-9, and on the corresponding F types. July saw the development of a new, strengthened wing, which incorporated MG 151s instead of the MG FFs in the outer position. The adoption of this wing developed into the Fw 190A-6 version. Further changes led to the Fw 190A-7, produced during the end of 1943. Further improvements led to the Fw 190A-8, the variant, which became the most produced with some 6,655 units made. The most significant change was the installation of the GM-1 nitrous-oxide injection system, used for temporary power boost in combat.

Reaching new heights

The fighter burden placed on the Fw 190A by the Luftwaffe was enormous. This very versatile aircraft found itself fulfilling fighter, fighter-bomber and ground support duties. Thanks to a robust airframe, the type was able to carry a wide variety of ordnance, which vastly improved upon the multi-role capabilities of the Luftwaffe's main fighter type, the Bf 109. Despite this, the design, which dated back to 1939, was showing its age towards the end of the war. The Fw 190A was falling short of its adversaries, especially at higher altitudes. The design development led first through the Fw 190B, powered by a BMW 801 with a turbo supercharger, followed by the Fw 190C, with in-line DB 603, but was finalized on the Fw 190D. Conversion to the D version, and namely the Fw 190D-9, involved installation of a new liquid cooled 12-cylinder Jumo 213A, rated at 1,726 hp. The front of the fuselage was therefore lengthened and in order to maintain the centre of gravity, there was a 50 cm extension at the rear of the plane as well. The overall length of the Fw 190D-9, compared to the A-9, was increased by 1.52 m (nearly 5 ft). The aircraft gained a new, more elegant shape, and was dubbed “Langnasen Dora” (Long-nose Dora). Other important changes in the type were the addition of MW 50 water methanol injection, temporarily boosting power output to 2,071 hp (1,545 kW), increasing maximum speed to 426 mph at 21,650 ft (680 km/h at 6600 m). Standard feature on the D-9 was the bulged canopy, covering an armored head and back rest for the pilot. Despite this, the first series of the Fw 190D-9 were equipped with the older, flat style canopy. The armament was composed of two 13 mm MG 131 machine guns mounted over the engine, and two MG 151/20 20 mm cannons in the wing roots.

Doras explained

All the modifications which the Fw 190D went through, were different enough to consider it a new aircraft. The first Fw 190D-9s were allocated to III./JG 54 in September 1944. This was followed by I./JG 26 in November and towards the end of the war there were some 183 Doras in service. According to some sources, more than 1,800 examples of Fw 190Ds were built. The D-9 led to other versions, of which only the D-11 and D-13 saw combat service. The more widely used D-11 differed from the D-9 first and foremost in armament, as the 13 mm machine guns were deleted, and two outboard wing mounted 30 mm cannons added. Upgraded Jumo 213E was also installed along with other improvements. The armament of the Fw 190D-11 was in fact similar to the Fw 190A-8/R-2, which is indicative of the planned use of the type against Allied formations of heavy bombers.

Out of over a thousand ordered D-13s, only 17 were built, and only a handful reached combat units. The armament of the D-13 composed of two 20 mm cannons in the wing roots and one firing through the propeller hub. The D-13 also had all-weather flying equipment, along with other relatively modern avionics. Some Doras were equipped with a larger tail unit (“Einheitsheck”) standardized on the Ta 152.

ATTENTION



UPOZORNĚNÍ



ACHTUNG



ATTENTION



注意



Carefully read instruction sheet before assembling. When you use glue or paint, do not use near open flame and use in well ventilated room. Keep out of reach of small children. Children must not be allowed to suck any part, or pull vinyl bag over the head.



Před započítím stavby si pečlivě prostudujte stavební návod. Při používání barev a lepidel pracujte v dobře větrané místnosti. Lepidla ani barvy nepoužívejte v blízkosti otevřeného ohně. Model není určen malým dětem, mohlo by dojít k požití drobných dílů.

INSTRUCTION SIGNS

* INSTR. SYMBOLS

* INSTRUKTION

* SINNBILDEN

* SYMBOLES

* 記号の説明

OPTIONAL
VOLBABEND
OHNOUTSAND
BROUSITOPEN HOLE
VYVRTAT OTVORSYMETRICAL ASSEMBLY
SYMETRICKÁ MONTÁŽREMOVE
ODŘÍZNOUTREVERSE SIDE
OTOČITAPPLY EDUARD MASK
AND PAINT
POUŽIT EDUARD MASK
NABARVIT

PARTS



DÍLY



TEILE



PIÈCES



部品

PLASTIC PARTS

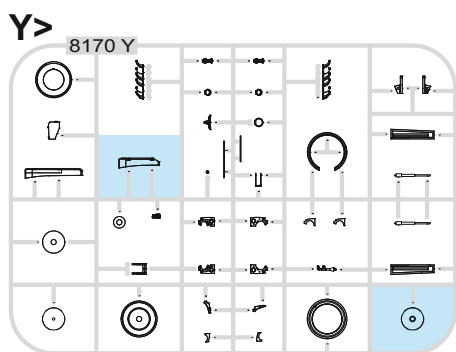
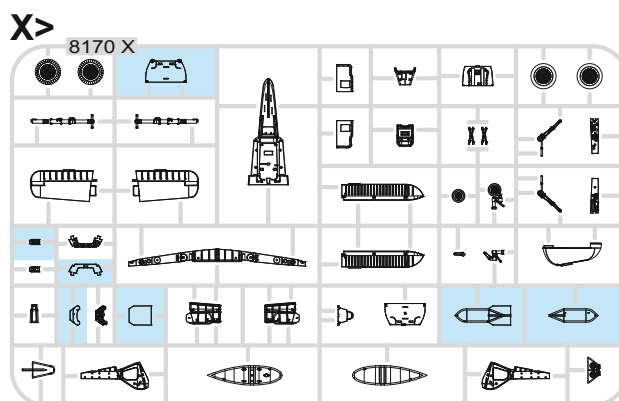
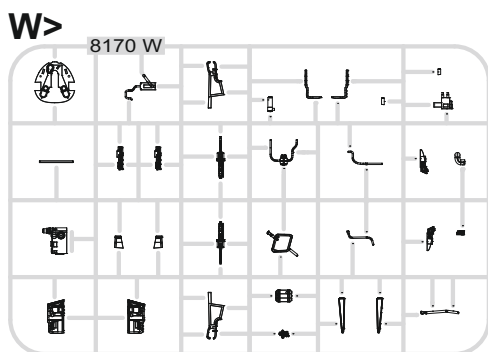
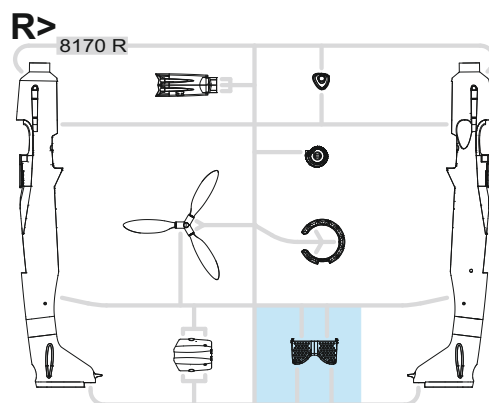
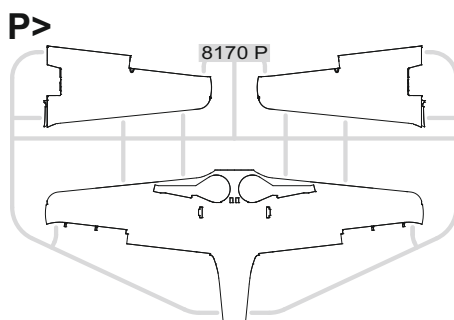
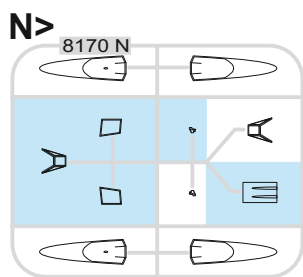

-Parts not for use. -Teile werden nicht verwendet. -Pièces à ne pas utiliser. -Tyto díly nepoužívejte při stavbě. - 使用しない部品

COLOURS



BARVY



FARBEN



PEINTURE



色

GSI Creos (GUNZE)		MISSION MODELS	
AQUEOUS	Mr.COLOR	PAINTS	
H2	C2	MMP-047	BLACK
H8	C8		SILVER
H11	C62	MMP-001	FLAT WHITE
H12	C33	MMP-047	FLAT BLACK
H47	C41	MMP-012	RED BROWN
H68	C36	MMP-049	RLM74 DARK GRAY
H69	C37	MMP-050	RLM75 GRAY
H70	C60	MMP-056	RLM02 GRAY
H77	C137	MMP-040	TIRE BLACK
H90	C47		CLEAR RED
H94	C138		CLEAR GREEN

GSI Creos (GUNZE)		MISSION MODELS	
AQUEOUS	Mr.COLOR	PAINTS	
H413	C113	MMP-090	RLM04 YELLOW
H414	C114	MMP-003	RLM23 RED
H416	C116	MMP-089	RLM66 BLACK GRAY
H417	C117	MMP-051	RLM76 LIGHT BLUE
H421	C121	MMP-052	RLM81 BROWN VIOLET
H422	C122	MMP-053	RLM82 LIGHT GREEN
Mr.METAL COLOR		METALLICS	
MC214		MMM-001	DARK IRON
MC218		MMM-003	ALUMINIUM
Mr.COLOR SUPER METALLIC		METALLICS	
SM201		MMC-001	SUPER FINE SILVER

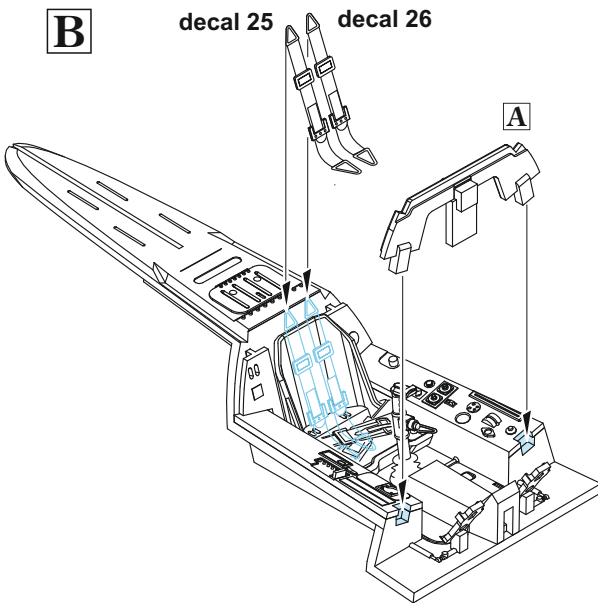
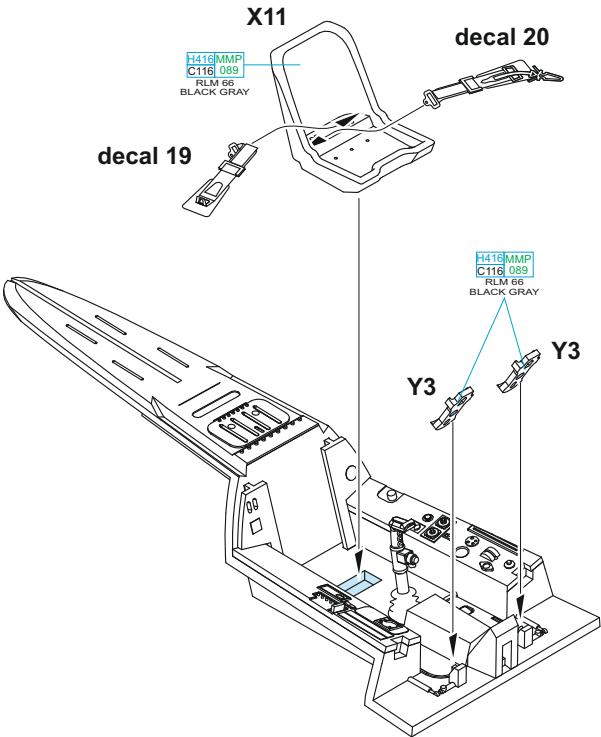
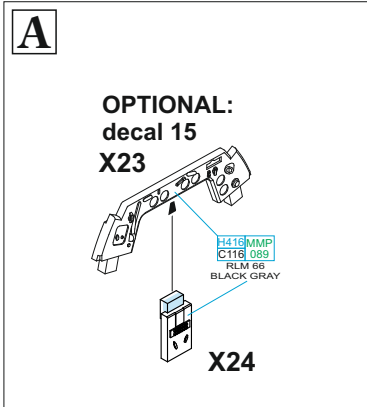
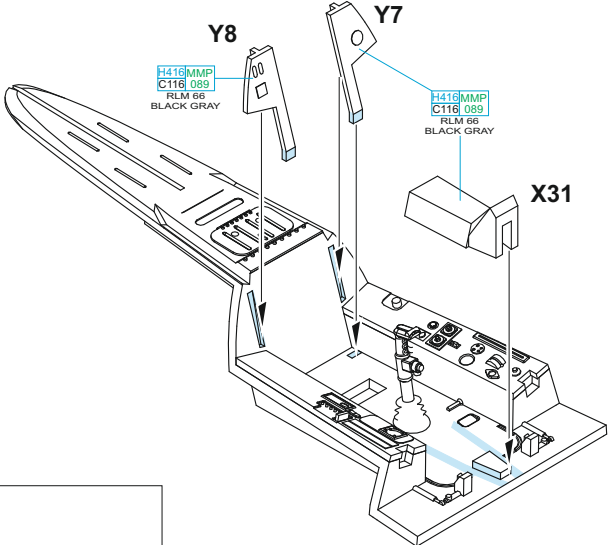
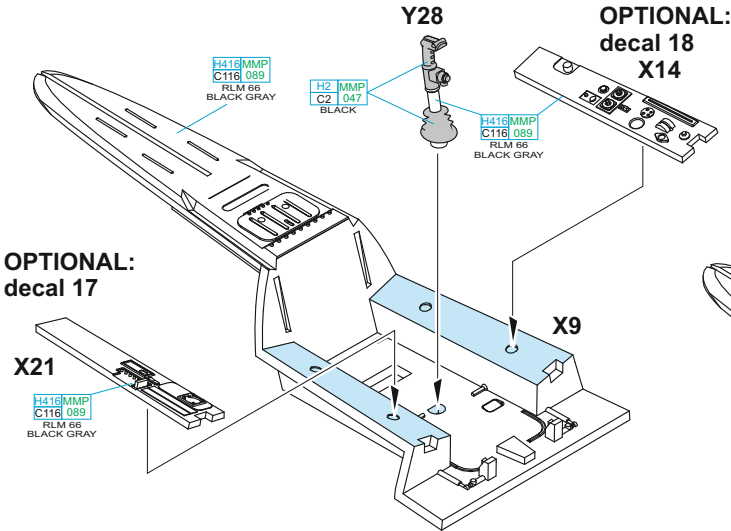
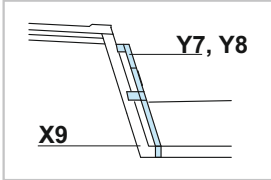

**DON'T INSTALL PARTS W12, W20, W3 AND W27 IF YOU ARE BUILDING THE MODEL WITH THE CLOSED FUSELAGE MG HOOD (R8).
POKUD STAVÍTE MODEL SE ZAVŘENÝM KRYTEM TRUPOVÝCH KULOMETŮ (R8), NEINSTALUJTE DÍLY W12, W20, W3 A W27**

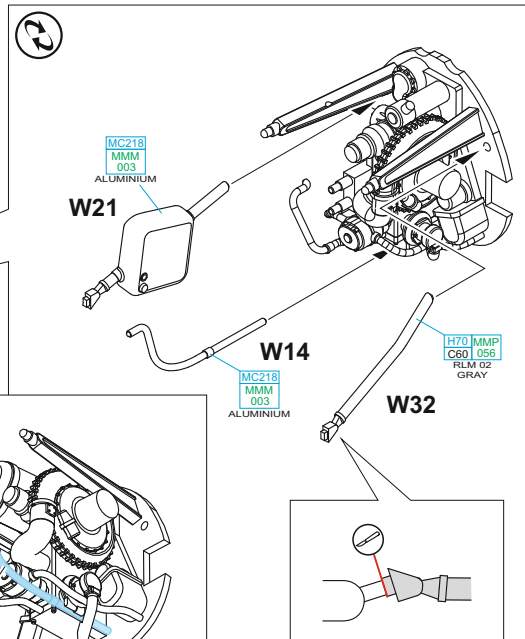
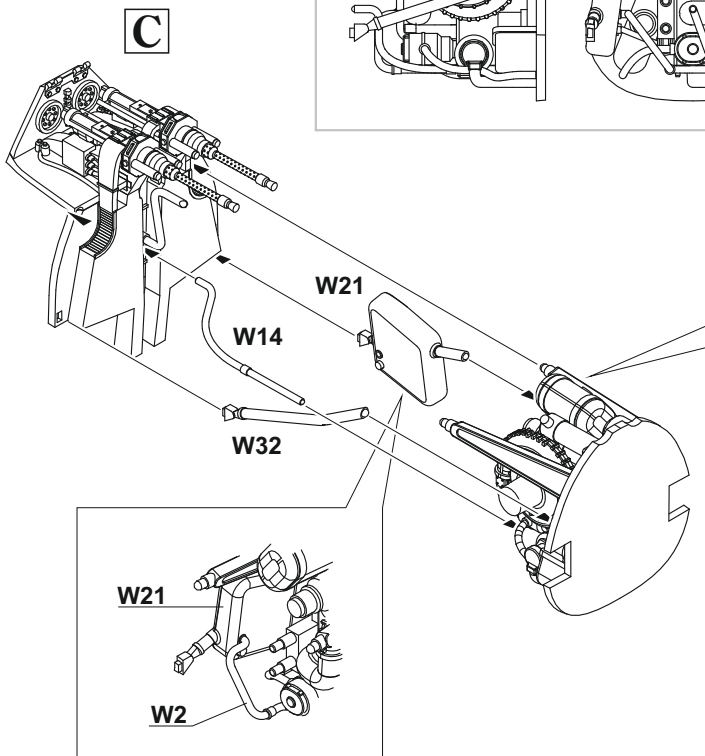
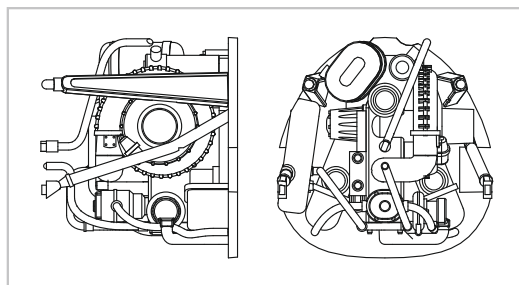
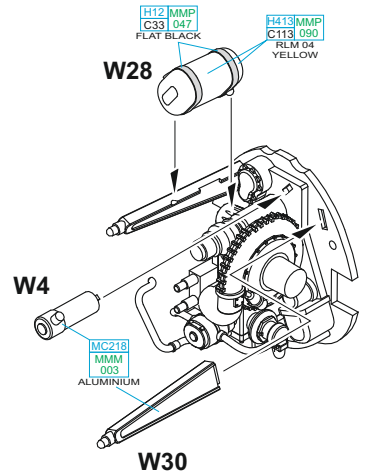
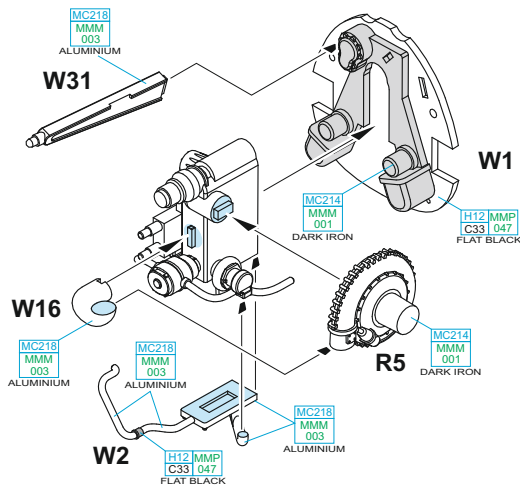
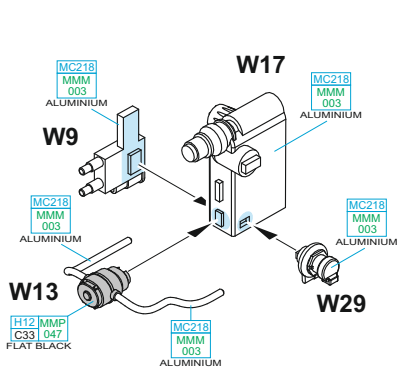
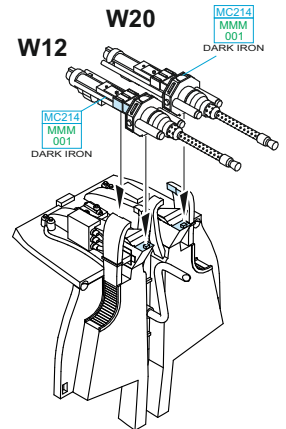
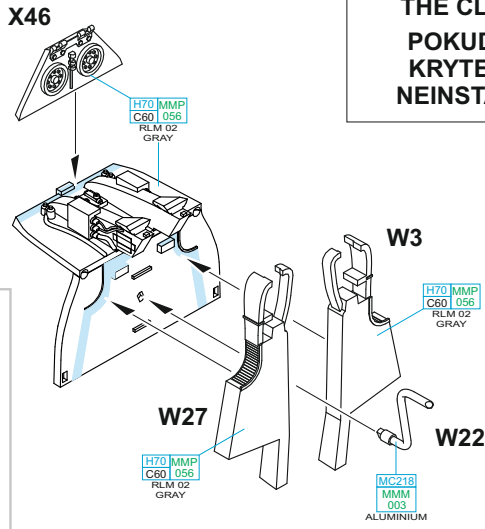
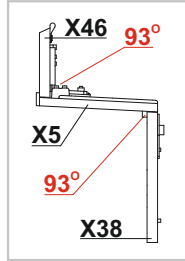
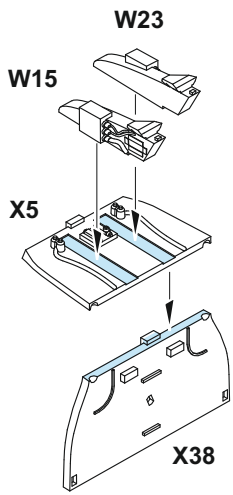

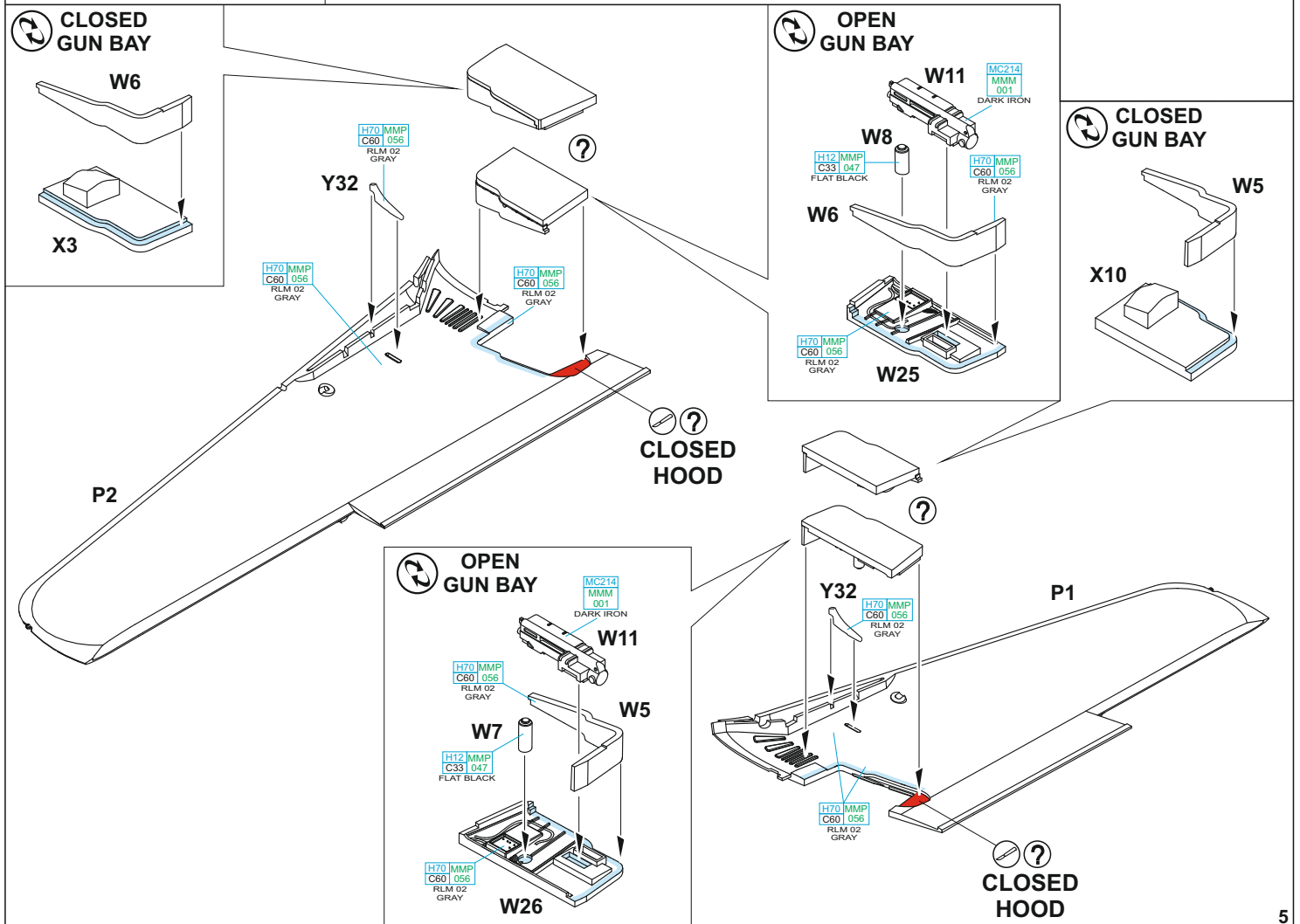
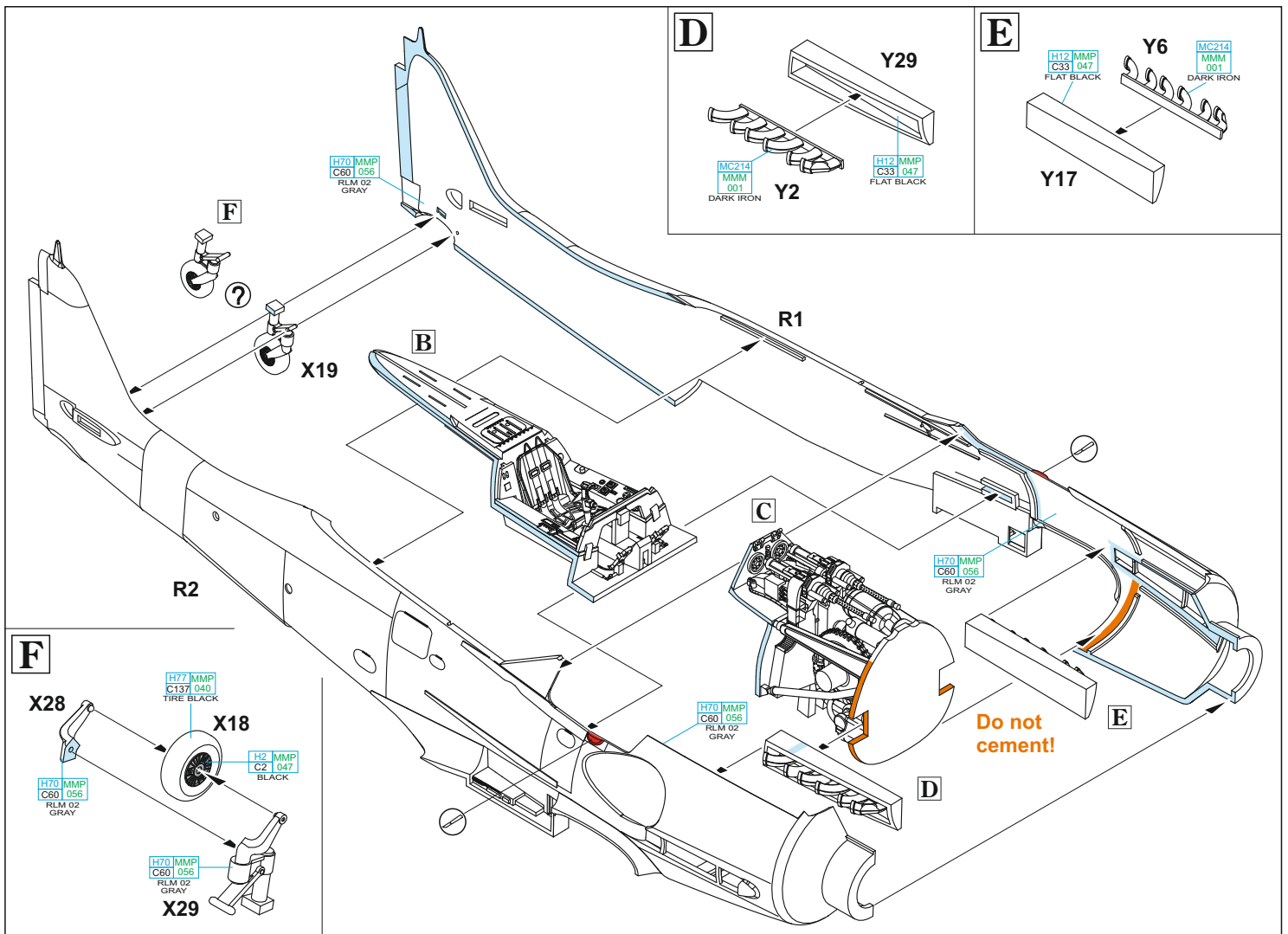

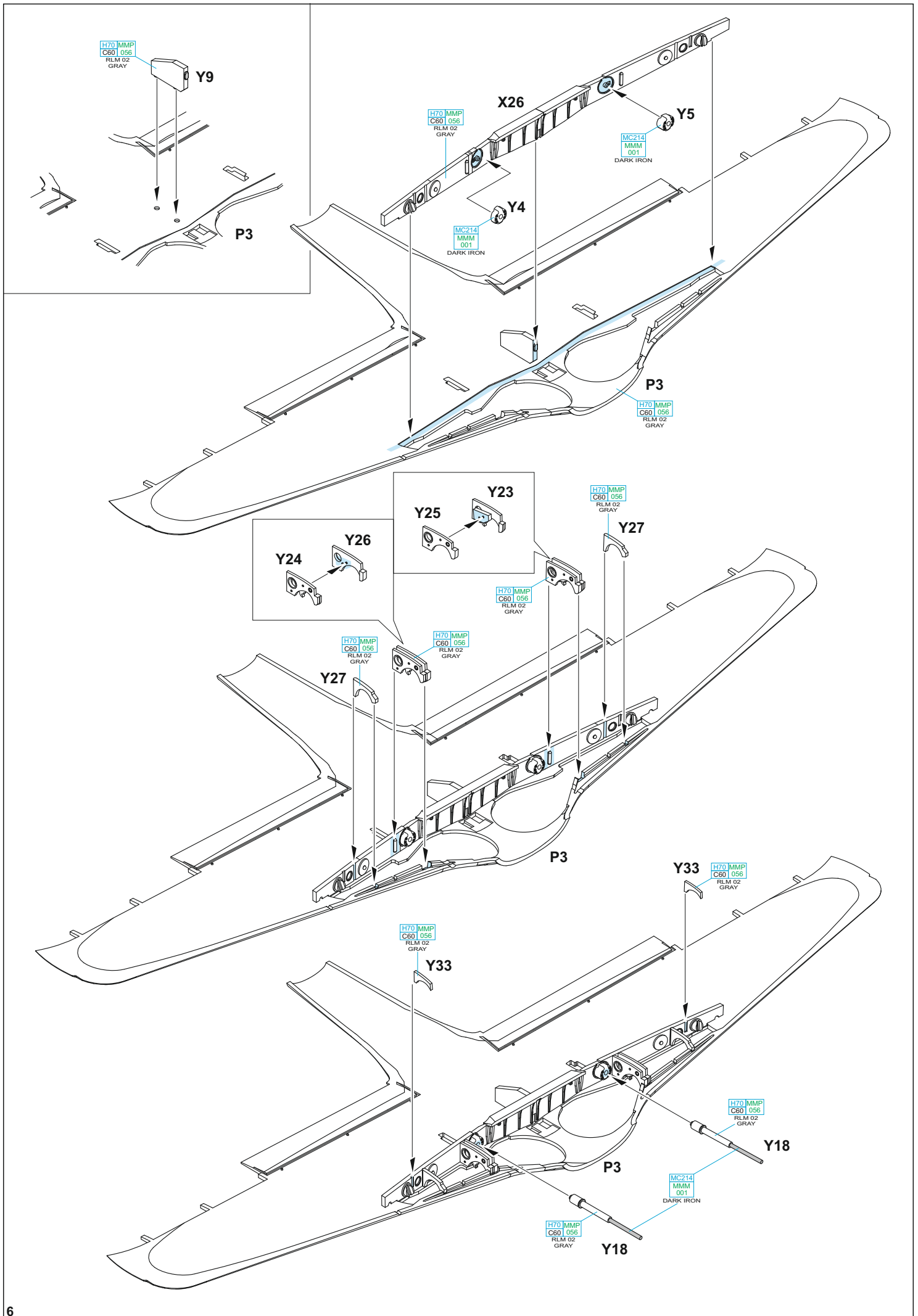

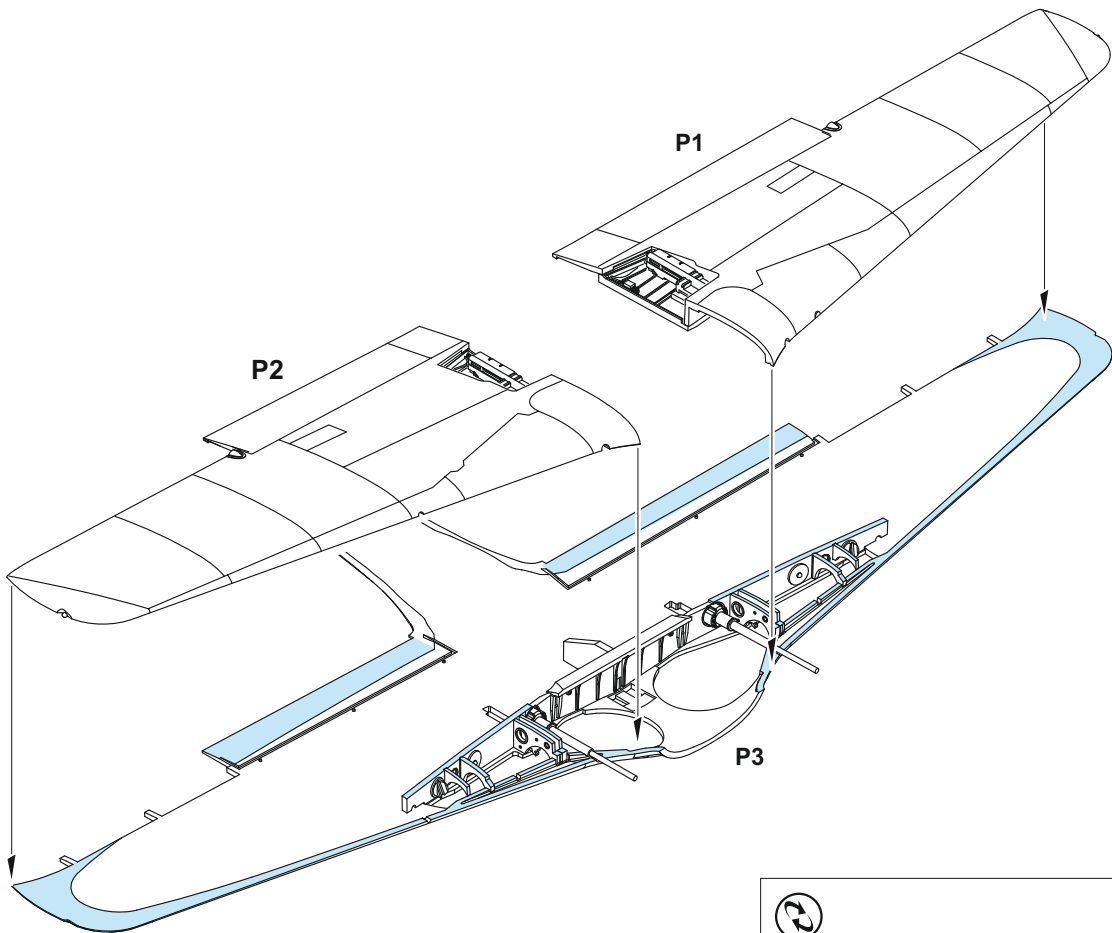

OPTIONAL:
decals 14

X33
H418 MMP
C116 099
RLM 66
BLACK GRAY

N4

X4
H416 MMP
C116 099
RLM 66
BLACK GRAY

X4
H417 MMP
C41 012
RED BROWN

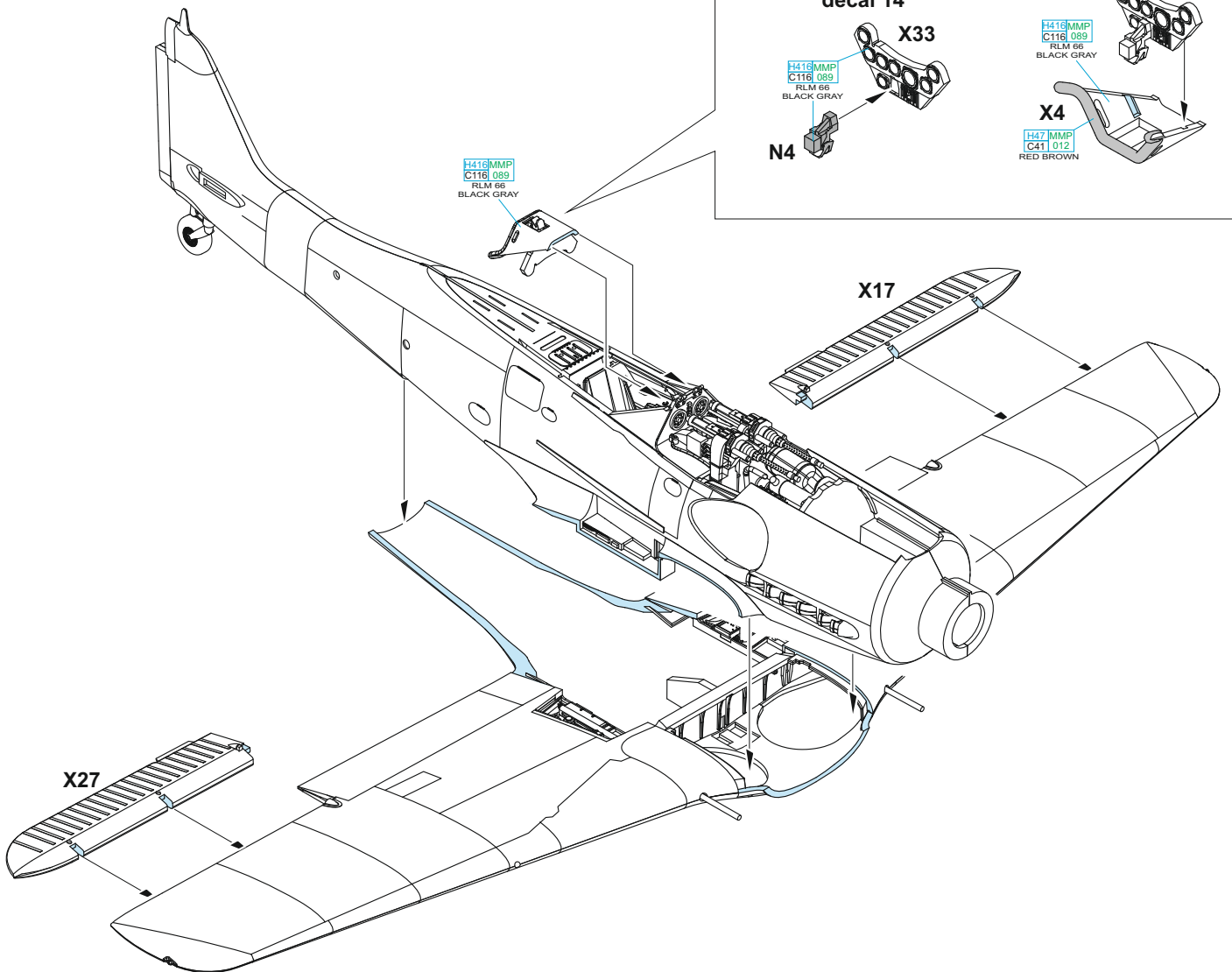

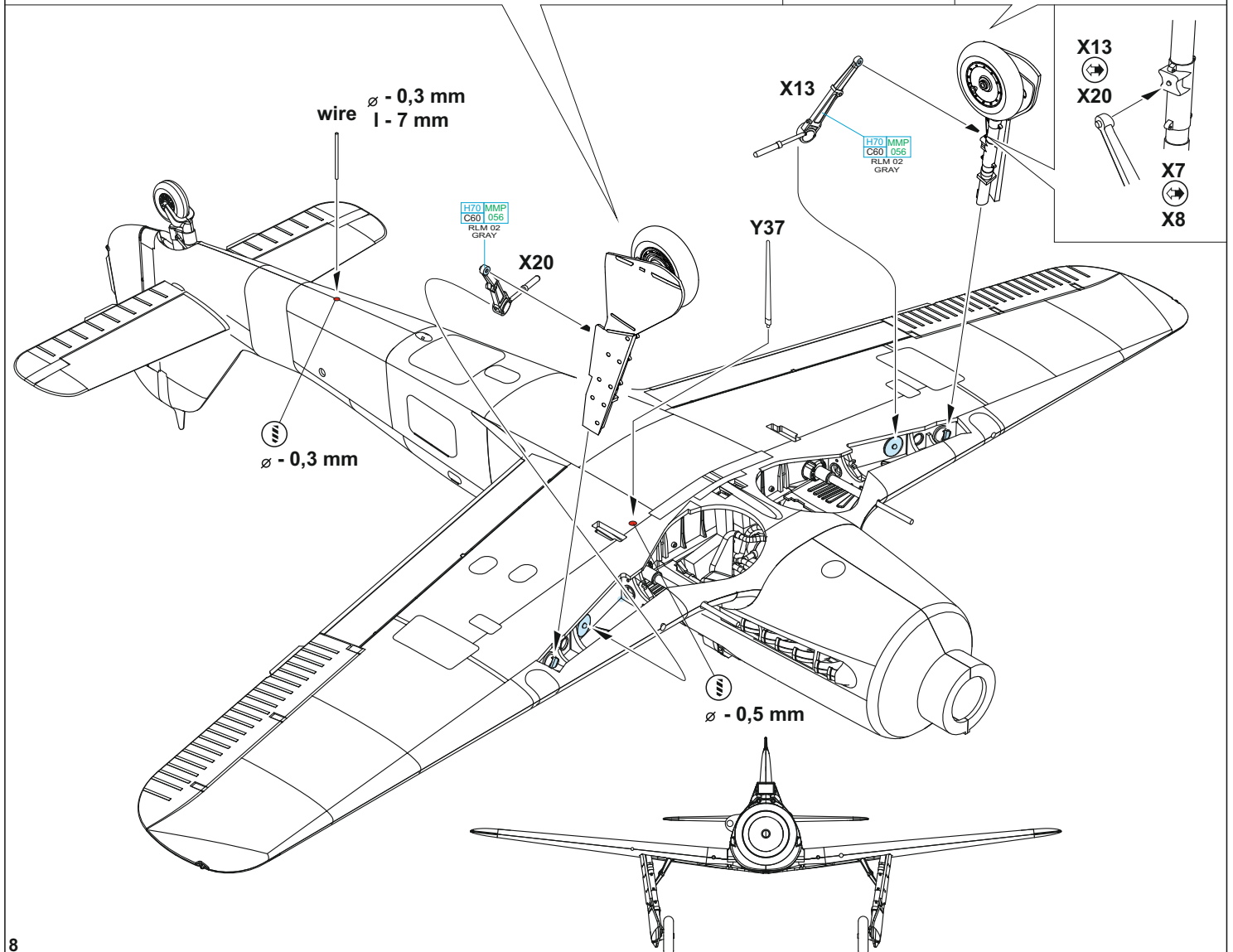
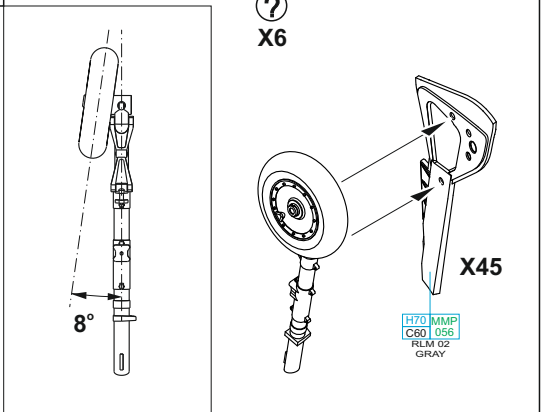
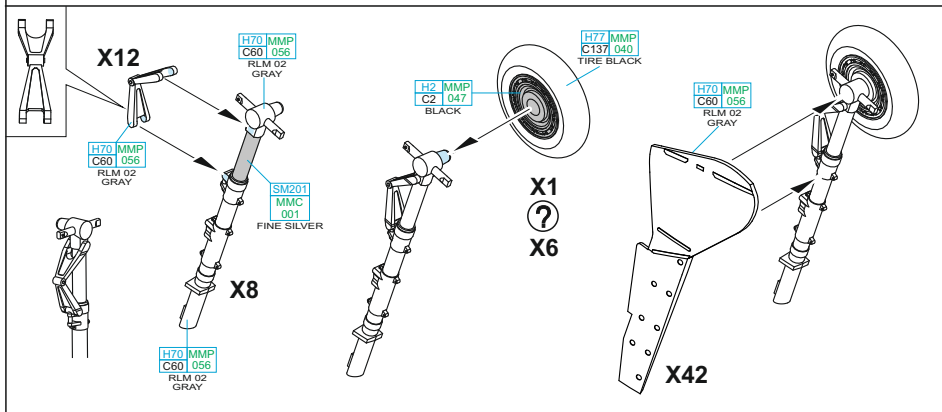
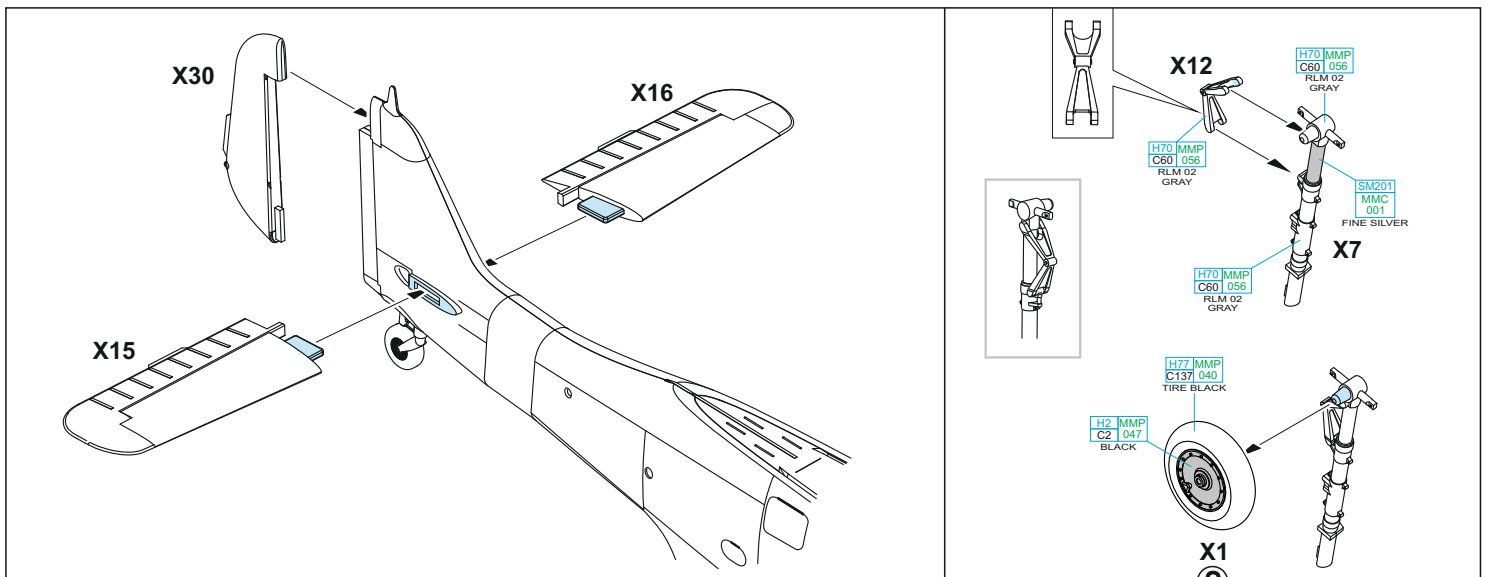

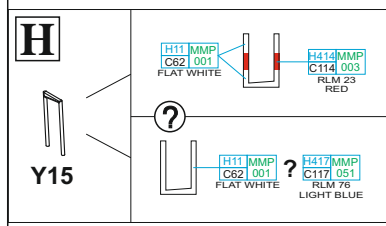
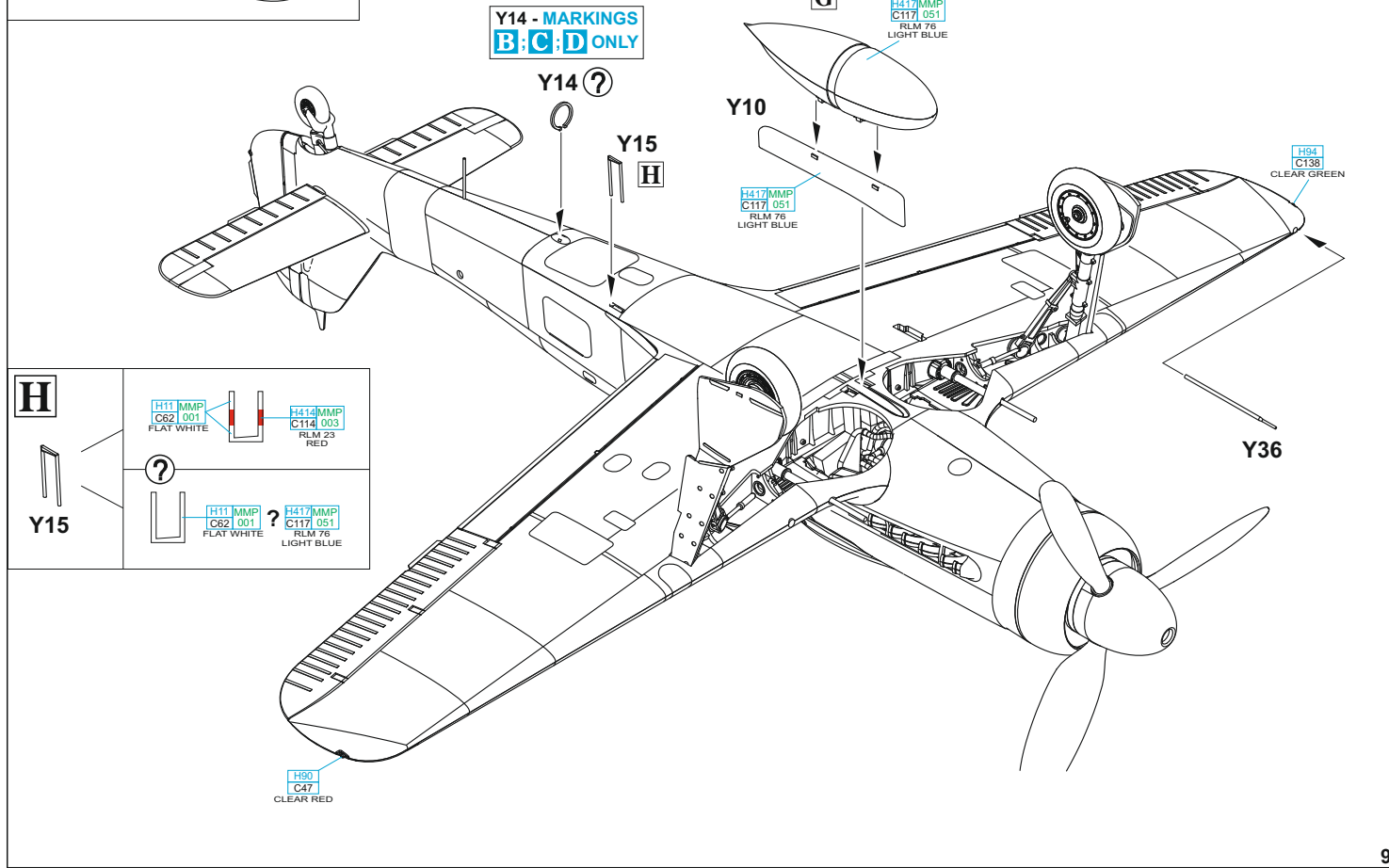
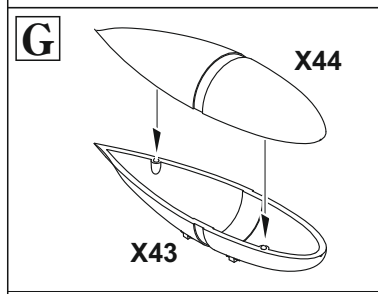
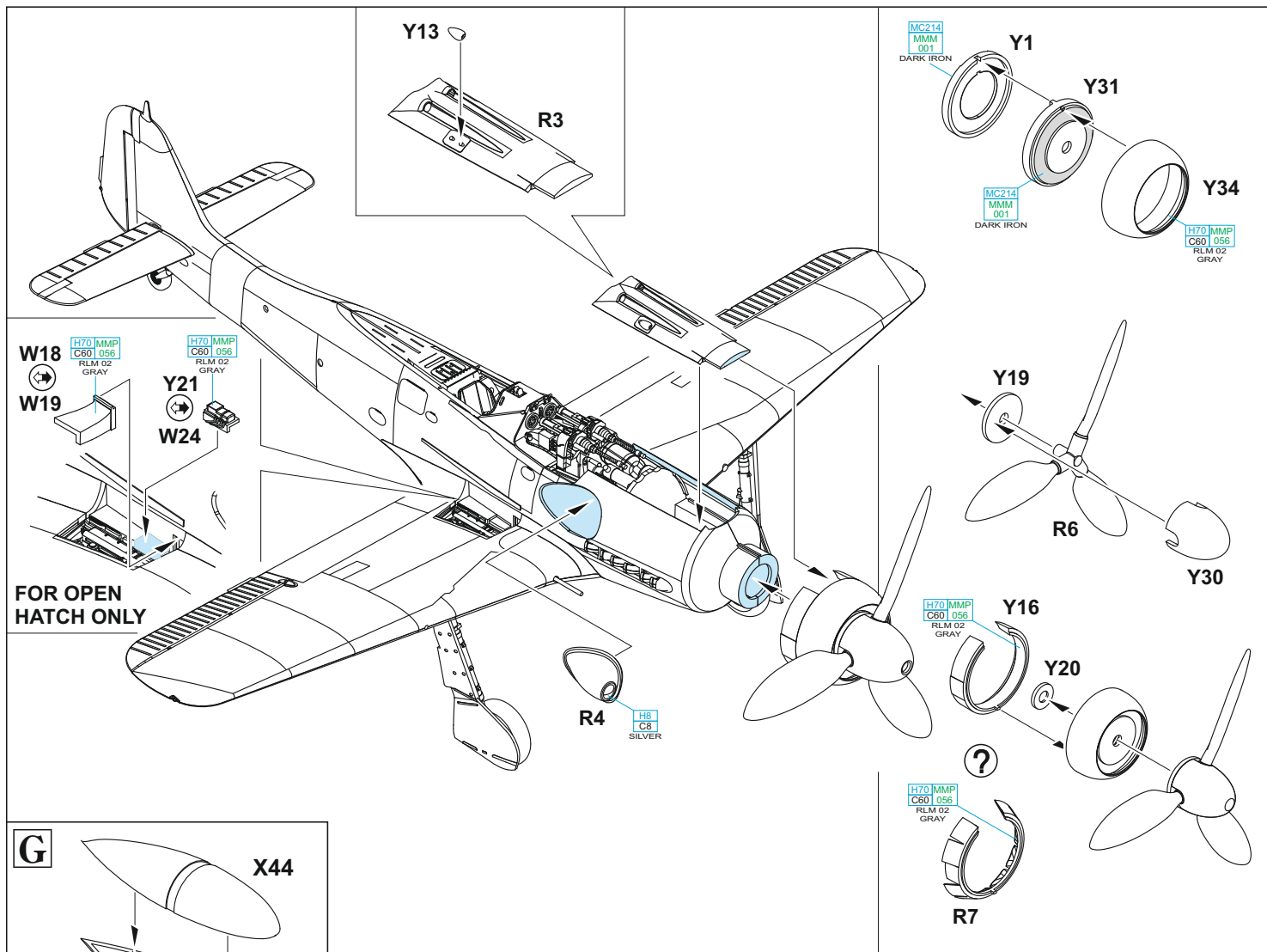

I MARKINGS **A,C,D**

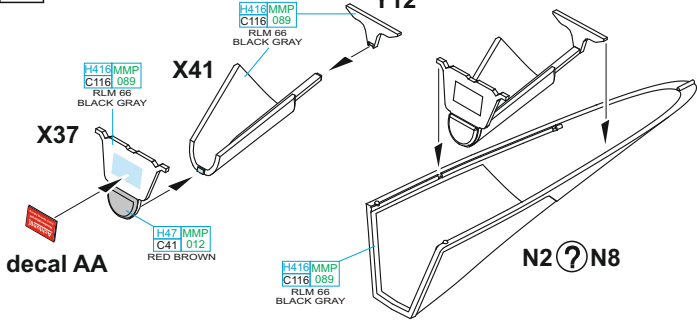

N2 - OPEN CANOPY N8 - CLOSED CANOPY

MARKING **B**

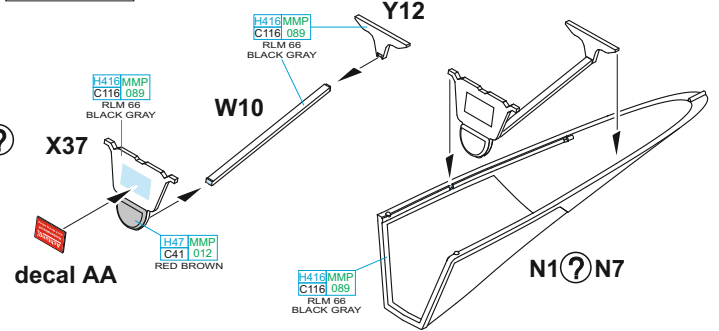

N1 - OPEN CANOPY N7 - CLOSED CANOPY

MARKINGS **A,C**

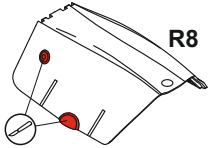

MARKING **B**

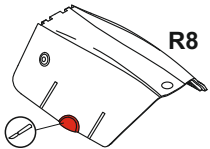

MARKING **D**

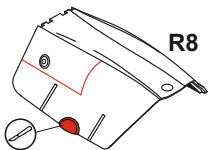

ADD PANEL LINE ON BOTH SIDES

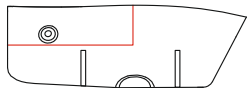

CLOSED HOOD

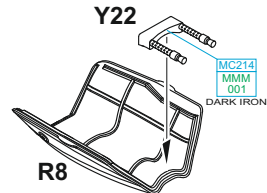

CLOSED X36

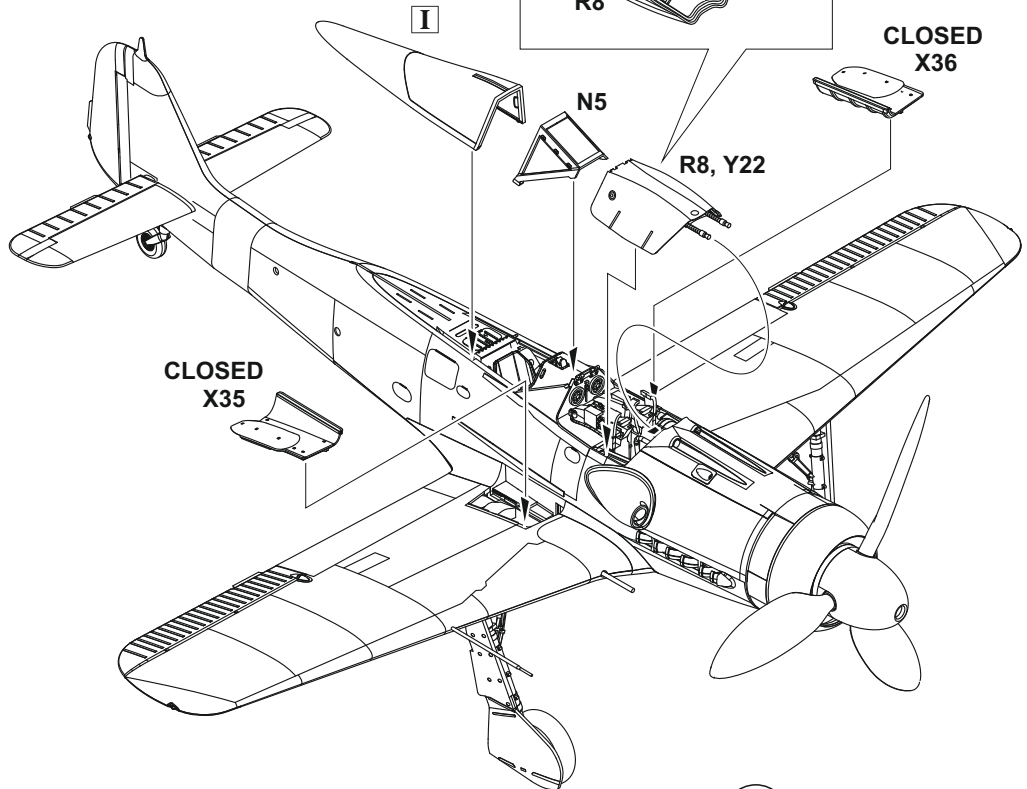

OPEN R8

OPEN X35

OPEN X36

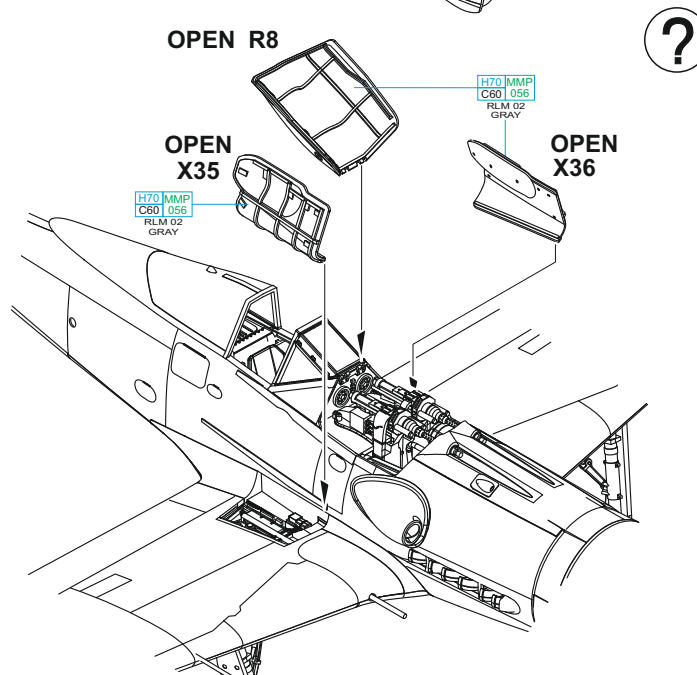

A WNr. 600424, Lt. Heinz Sachsenberg, München-Riem, Germany, April-May 1945

Lt. Heinz Sachsenberg (104 victories) was the CO of Platzschutzschwarm. The aircraft assigned to Sachsenberg carried the inscription 'Verkaaft's mei Gwand, I foahr in himmel', which is a Bavarian proverb 'sell my shroud, I am leaving for Heaven'. The font was Schwab, which was popular at the time. Sachsenberg, holder of the Knight's Cross, came from an aviation family. His uncle Gotthard was a World War I ace and holder of Pour le Mérite, as he shot down 31 enemy aircraft. Heinz's brother, also named Gotthard, flew a night fighter with NJG 3 and shot down two British bombers and fell on March 8, 1943. Sachsenberg's 'Dora' was found at the end of the war at Munich-Riem, where it was left behind after the JV 44 fled to Austria at the end of April 1945.

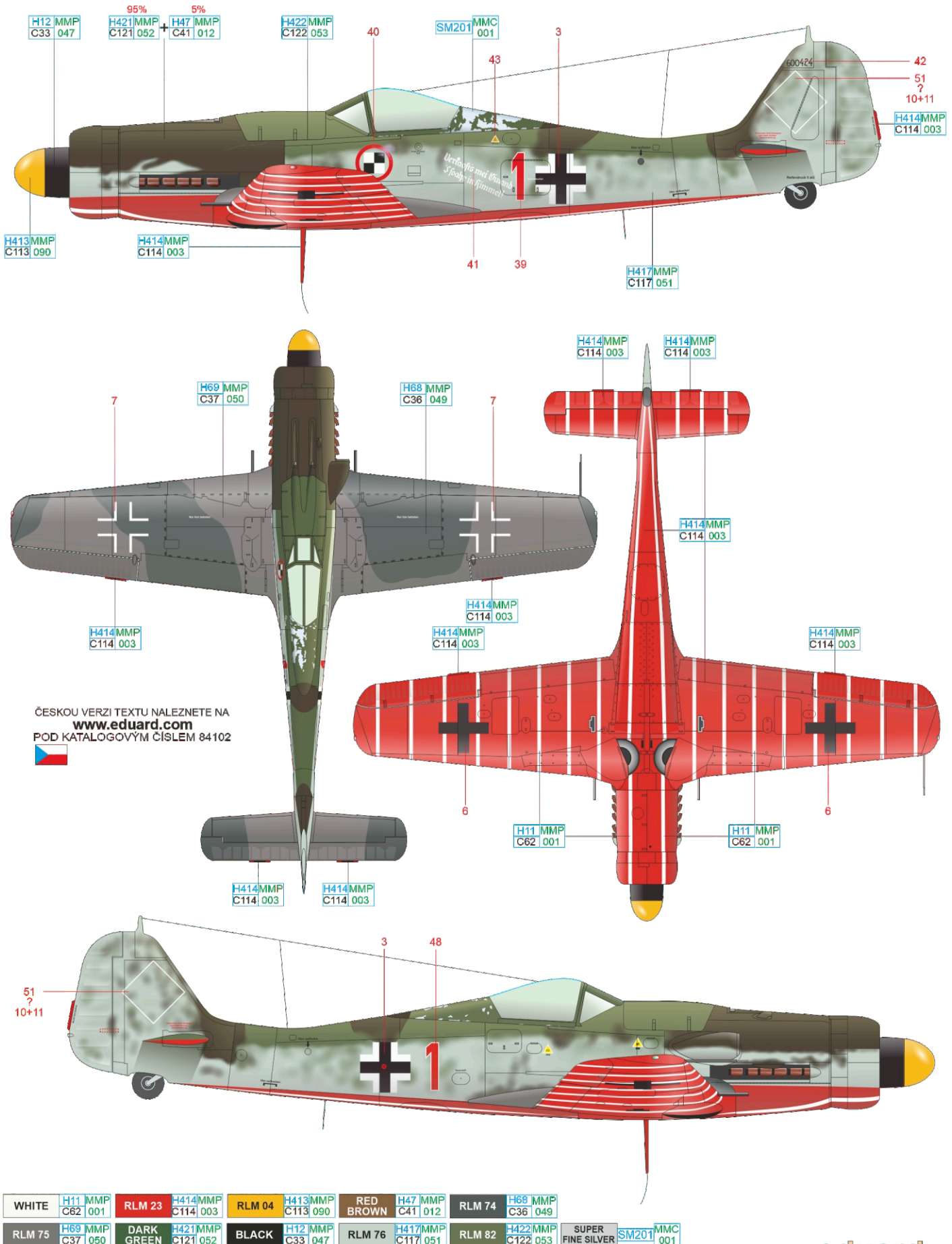

Fw. Werner Hohenberg, took part in the raid on St. Trond airport flying as a part of the I./JG 2 staff flight of commander Franz Hrdlicka. During this sortie Hohenberg's aircraft was hit in the tail surfaces and on return the engine of his aircraft was hit by the anti-aircraft gun projectiles. At 9:35 he force-landed at Dorff village and spent the rest of the war in captivity. The B Battery of the 430th AAA Batalion was credited with shooting him down. Hohenberg's Dora sports a typical Sorau factory camouflage in RLM 75/81/76 on the fuselage and also on the wings. The spiral was painted on the front part of the propeller spinner only. Stripes on the rear fuselage indicate JG 2 deployment in the Reich Defense role.

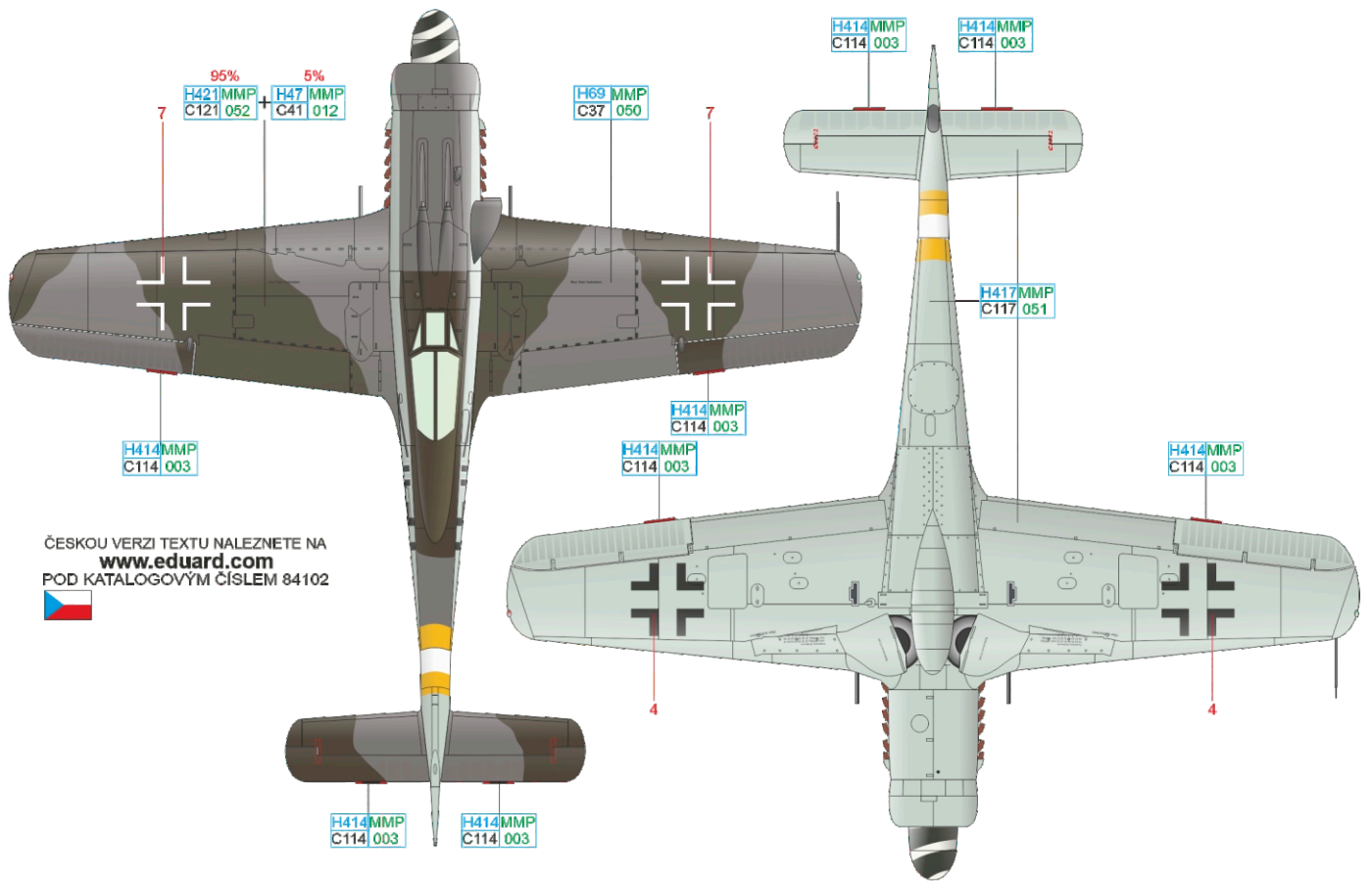
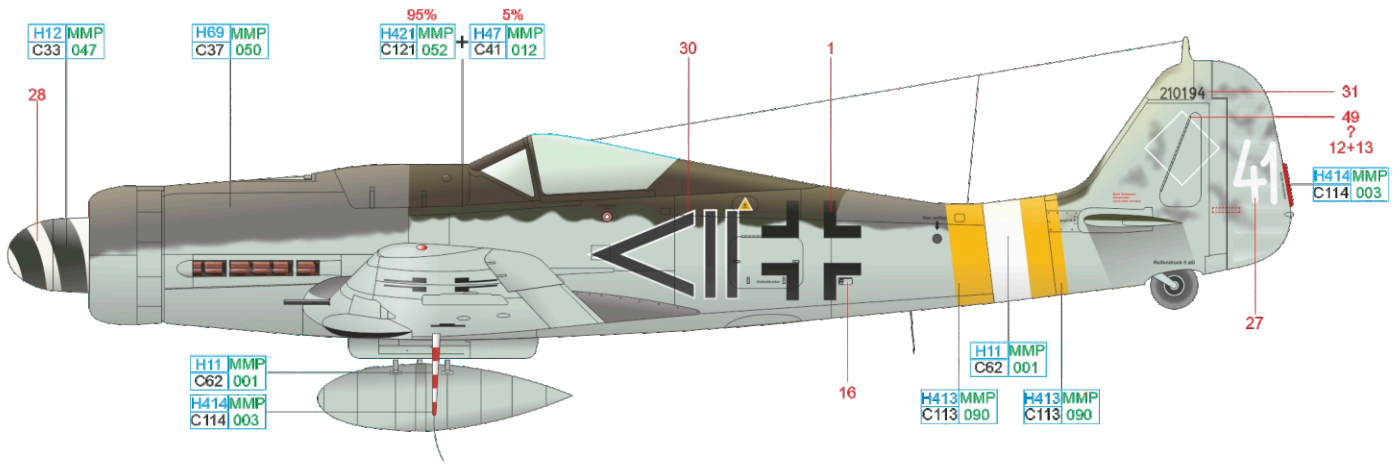

ČESKOU VERZI TEXTU NALEZNETE NA
www.eduard.com
POD KATALOGOVÝM ČÍSLEM 84102

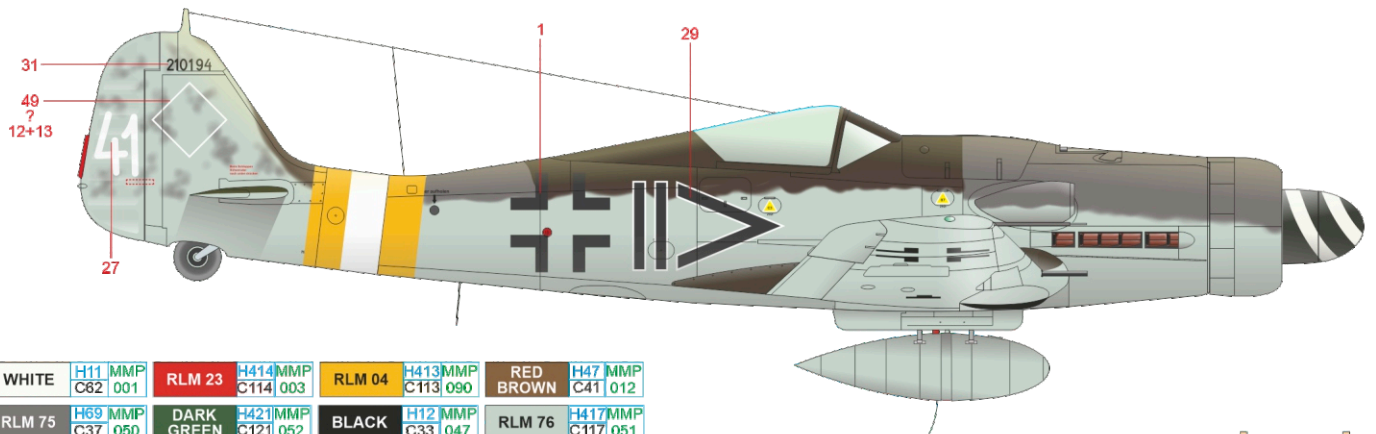

WHITE	H11 MMP C62 001	RLM 23	H414 MMP C114 003	RLM 04	H413 MMP C113 090	RED	H47 MMP C41 012
RLM 75	H69 MMP C37 050	DARK GREEN	H421 MMP C121 052	BLACK	H12 MMP C33 047	RLM 76	H417 MMP C117 051

The personal aircraft of Gerhard Barkhorn, the new CO of JG 6 at the time, was manufactured by the Focke-Wulf factory in Sorau. The name 'Christl' is a reference to Barkhorn's wife Christa. Marking on the fuselage identifies the Geschwader's CO aircraft. Barkhorn achieved 301 aerial victories during WWII, all of them as a member of JG 52, putting him in second place among German fighter aces. His first victory was achieved on July 2, 1940 and the last on January 5, 1945. In 1945, Barkhorn became the CO of JG 6 and flew Me 262 jet fighters as a member of JV 44 shortly before the German surrender. Barkhorn was awarded the Knight's Cross on August 23, 1942, with Oak Leaves (on January 11, 1944) and Swords (on March 2, 1944). In the post-war era, he joined Bundesluftwaffe.

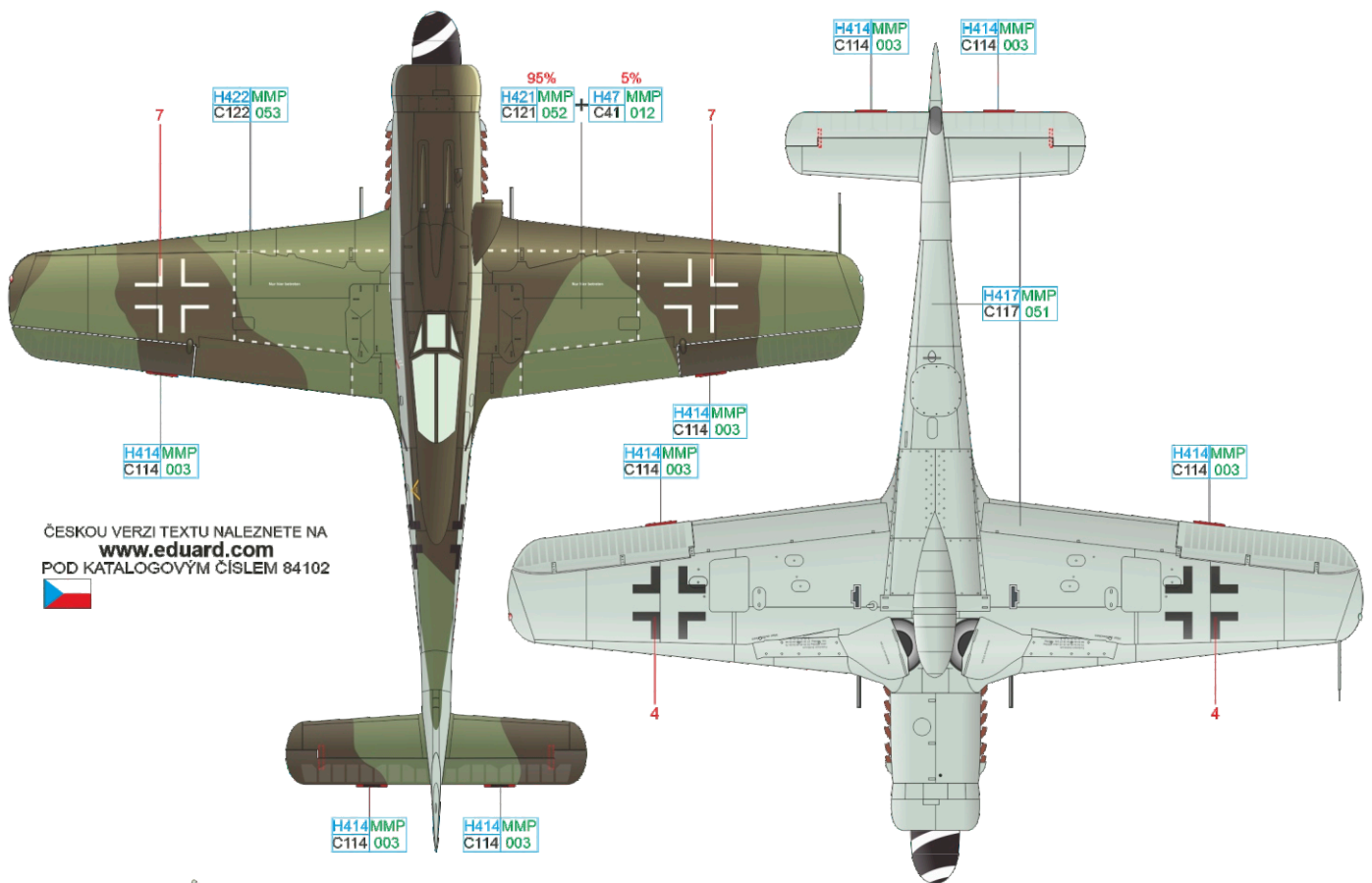
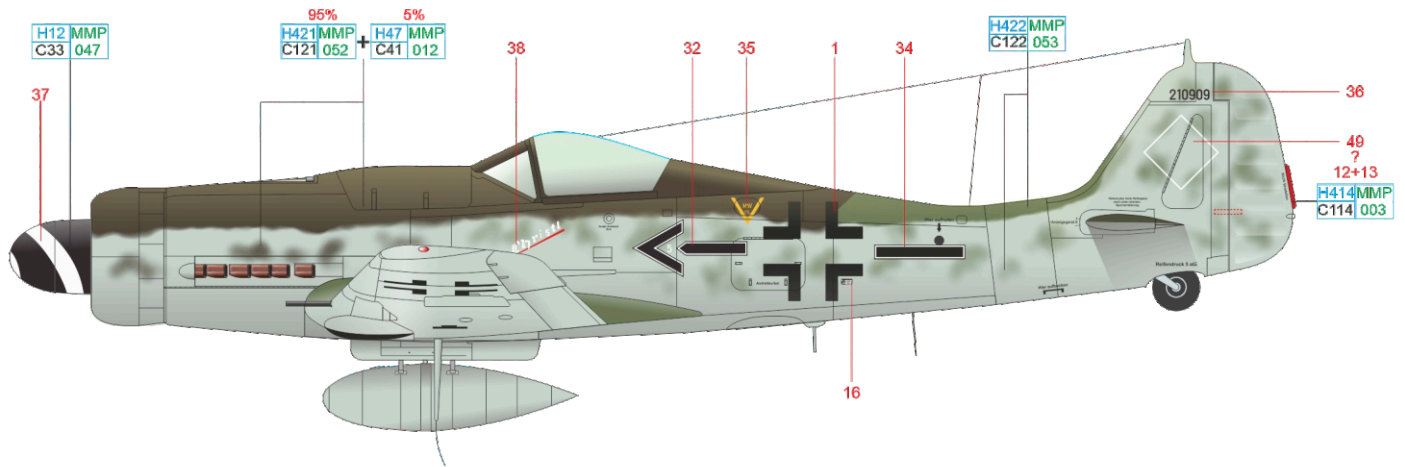

ČESKOU VERZI TEXTU NALEZNETE NA
www.eduard.com
POD KATALOGOVÝM ČÍSLEM 84102

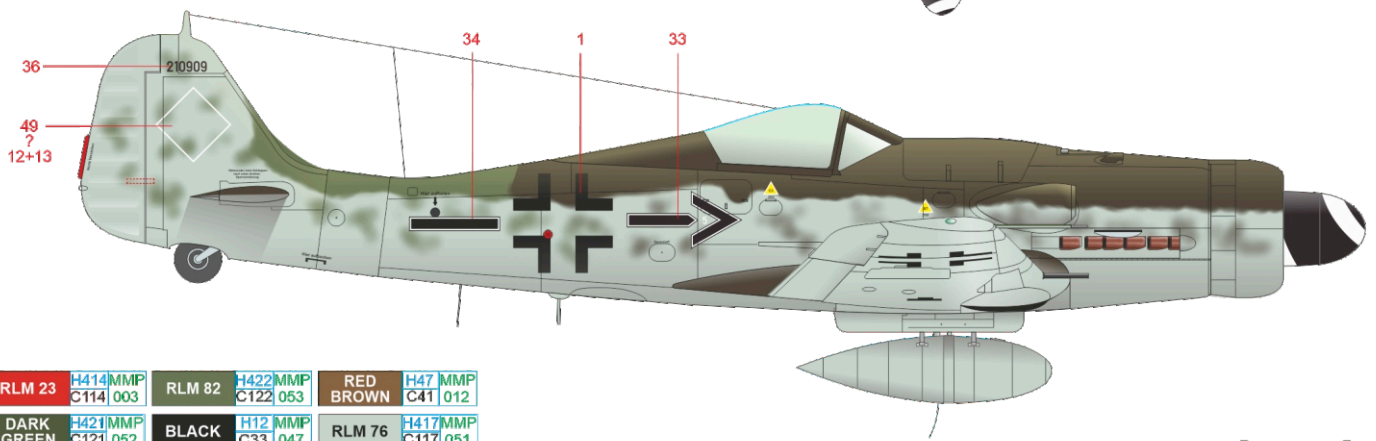

RLM 23	H414 MMP C114 003	RLM 82	H422 MMP C122 053	RED BROWN	H47 MMP C41 012
DARK GREEN	H421 MMP C121 052	BLACK	H12 MMP C33 047	RLM 76	H417 MMP C117 051

D WNr. 210003, Oblt. Hans Dortenmann, 12./JG 26, Germany, 1945

Oblt. Hans Dortenmann, a 38-kills fighter ace and Knight's Cross holder, noted in his memoirs that he used Dora WNr. 210003 as a personal mount from September 1944 to the end of hostilities. He personally destroyed her to avoid falling into enemy hands at the end of the war. At first, during Dortenmann's service with III./JG 54, the airplane was marked 'Red 1'. In late February III./JG 54 was redesignated IV./JG 26, and Dortenmann was appointed Staffelkapitän of 12./JG 26. His Dora became 'Black 1'. The White-Black band appeared on the tail as well as IV. Gruppe's wave. According to Dortenmann's memoirs, the original RLM 74/75 camouflage scheme was changed to RLM 81/82, but the reason for re-painting remains unknown. A new style blown canopy was installed instead of the original flat one. The vertical part of the tail unit was painted yellow from JG 54 days.

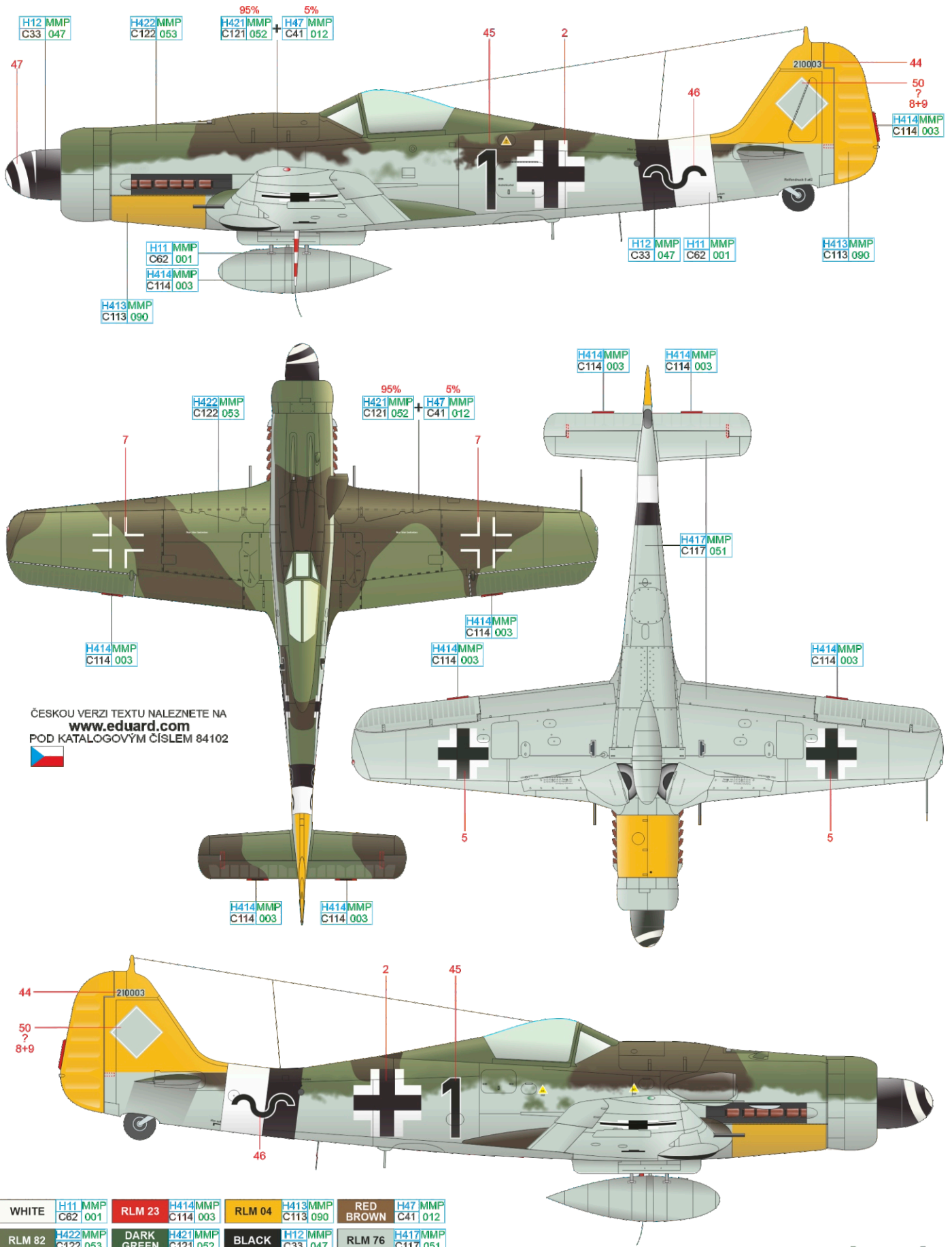

ČESKOU VERZI TEXTU NALEZNETE NA
www.eduard.com
 POD KATALOGOVÝM ČÍSLEM 84102



WHITE	H11 MMP C62 001	RLM 23	H414 MMP C114 003	RLM 04	H413 MMP C113 090	RED BROWN	H47 MMP C41 012
RLM 82	H422 MMP C122 053	DARK GREEN	H421 MMP C121 052	BLACK	H12 MMP C33 047	RLM 76	H417 MMP C117 051

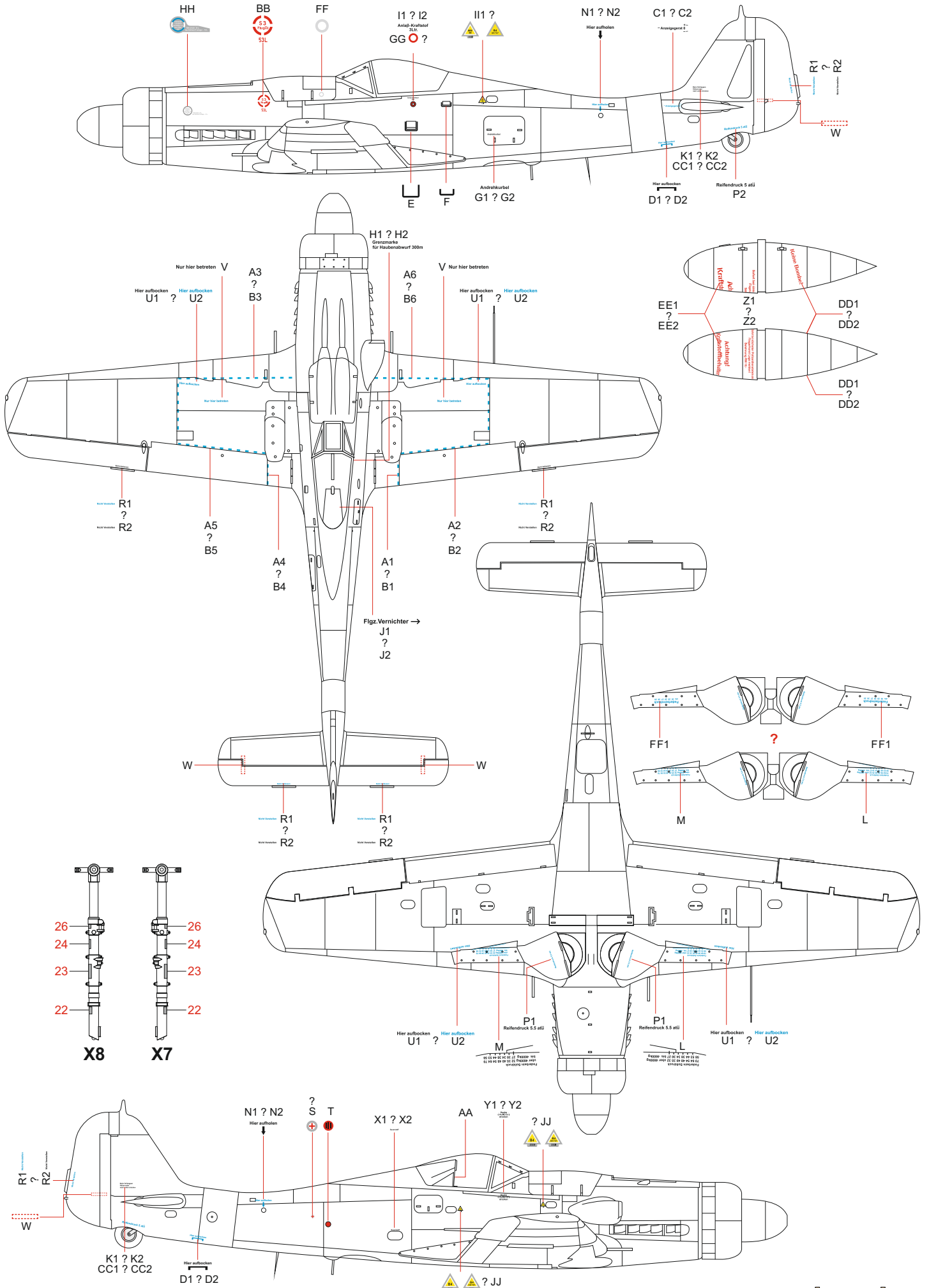

Eduard goodies for

Fw 190D-9 1/48

- 48651 Fw 190D-9 (PE-Set)
- FE1209 Fw 190D-9 Weekend (PE-Set)
- 644014 Fw 190D-9 LööK (Brassin)
- 648150 Fw 190 wheels late (Brassin)
- 648356 Fw 190A wingroot gun bays (Brassin)
- 648439 Fw 190D fuselage guns (Brassin)
- EX328 Fw 190D Weekend (Mask)

Cat. No. 644014



Cat. No. 648439

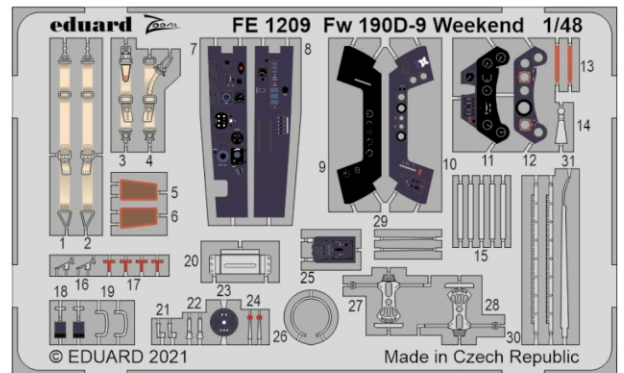
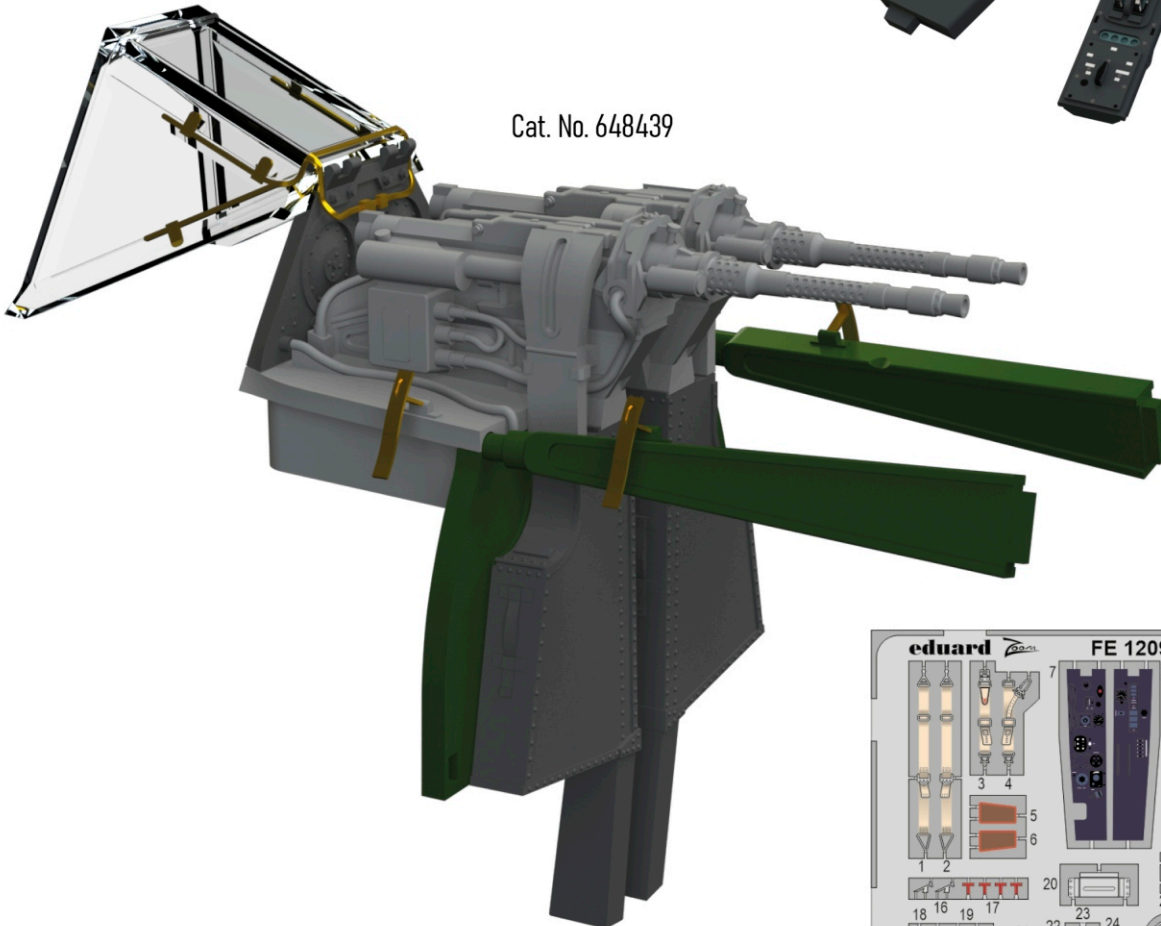

Cat. No. 648356



Cat. No. 648150

