

# MiG-21bis

eduard

1/48 Scale Plastic Model Kit

**WEEKEND**  
edition



item # 84130

**The MiG-21 was the most-produced supersonic fighter in the world and served with more than fifty Air Forces over four continents. This tiny interceptor or fighter-bomber played remarkable role in many wars and local conflicts from sixties to eighties, allowing many pilots to achieve their ace combat status.**

The MiG-21 was one of a long-lists of Mikoyan-Gurevich designs to be integrated into the armed forces of the Soviet Union, the Warsaw Pact, and allied client states. Its predecessors included such notable types as the MiG-15, MiG-17, and the supersonic MiG-19.

The roots of MiG-21 project reach back to the first half of the fifties. In 1954, when the preliminary design study Ye-1 came to its end and was quickly replaced by the reworked Ye-2 prototype. Both had a swept wing. The first MiG design to feature the delta wing was the Ye-4 prototype, which took to the air for the first time on June 16, 1955. It was also demonstrated a year later at the Moscow airfield Tushino.

The new aircraft with the MiG-21 designation was the first successful Soviet design integrating fighter and interceptor characteristics. It was also quite light Mach 2 aircraft, although the long-lasting development was adding weight gradually. The design featured sleek fuselage with the front air intake and shock cone. This feature later limited future development due to the very small space available for the radar.

#### Cold War warrior

The first of the new line to enter production was the MiG-21F, which together with the MiG-21P and MiG-21F-13 represented the first generation of this line. These versions were in production through the end of the fifties and the beginning of the sixties. Subsequent versions included the PF, FL, PFM and R with production of these peaking at the end of the sixties. The third generation started production in 1968 and included the most advanced versions of MiG-21 like the M, SM, MF, SMT or bis among others. Simultaneously, two-seat training versions were also produced designated MiG-21U, UM and US.

Production of the MiG-21 ended in 1985. The new aircraft came off Soviet production lines in Moscow, Gorky and Tbilisi, the MiG-21F-13 was also built under license in Czechoslovakia and the MiG-21FL, M and bis in India by Hindustan Aeronautics Ltd. The Soviet Union produced 10,645 examples of all versions, 194 were built in Czechoslovakia and 657 in India. That counts 11,496 aircraft produced.

Over the course of the Cold War, the opponents of the MiG-21 included the likes of the Northrop F-5 Freedom Fighter or the Dassault Mirage III. NATO assigned it the reporting name "Fishbed", while the Soviet pilots called it "Balalaika" due to the shape resembling it with the popular Russian musical instrument.

#### Aces from Asia, Middle East or Africa

Outside of the Soviet Union, the type flew with a long list of nations on four continents (Europe, Asia, Africa and South America) and participated in many conflicts and wars. The most remarkable combat use

includes the Vietnam war, the Indo-Pakistan wars, the Cuban participation in Angola and in the Arab world's attempts to eliminate Israel. It was no wonder there were many pilots achieving their ace status flying one or more variants of MiG-21.

Thanks to the high volume of use and intensive combat actions, the Vietnamese pilots are topping the list of aces of MiG-21. The top of the ladder is occupied by Nguyen Van Coc (9 kills) with three eight-victory aces following: Mai Van Cuong, Nguyen Hong Nhi and Pham Thanh Ngan. From the other nations the Syrian pilots Bassam Hamshun and Majid Zugbi both achieved seven kills flying MiG-21MF, while Adeeb Al-Jarf had the same score with MiG-21FL and Egyptian pilots Ali Vajai, Sami Marei and Sami Marei scored five times.

In the interceptor role the MiG-21 served with the Soviet Union and other nations of the Warsaw Pact into the eighties when it began to be replaced by the MiG-23 in seventies and MiG-29 Fulcrum in eighties.

#### This kit: MiG-21bis

The MiG-21bis had designation "Izdelye 75" in factory documentation. As opposed to the MF and SMT versions, it was intended to be a fighter with ground attack capability as only the secondary role. It was powered by a Tumanskiy R-25-300, the engine was more powerful than unit used with MiG-21SM and it also offered better economy. The maximum thrust rose from 6,490 kp of the R-13-300 to 9,900 kp of the R-25-300. Because of the change of the engine, the diameter of the frontal air inlet had to be enlarged from 870 mm to 900 mm. The regulation cone stayed the same as with the SM version, but the radar inside was changed from the RP-22SM unit to the RP-22M (Jay Bird) one, capable to follow the air targets when detected against the ground surface background. There was also bigger No. 7 fuel tank installed (600 l instead of 510 l) in the fuselage, which necessitated bigger, more spacious fuselage ridge. But it was not as big as with the MiG-21SMT version, where the huge 900l tank affected the general performance of the aircraft negatively.

The MiG-21BIS was armed with a twin barreled GSh-23-2L 23mm cannon with 200 rounds per weapon. Hardpoints could be loaded with R-13M, R-55, R-60 and R-60M missiles, UB-16-57 or UB32A rocket pods, S-24 unguided rockets, bombs up to 500 kg caliber, and ZB-360 napalm bombs.

The aircraft was delivered to nations of the former Warsaw Pact and the Third World either as the model "Izdelye 75A" with the Lazur ground control intercept system, or as the "Izdelye 75B" with the Polyot OI ILS (Instrument Landing System). The former carried the NATO code "Fishbed N", and the latter "Fishbed K". Both versions served as "Izdelye 75" with Soviet VVS and PVO units.

ATTENTION



UPOZORNĚNÍ



ACHTUNG



ATTENTION



注意



Carefully read instruction sheet before assembling. When you use glue or paint, do not use near open flame and use in well ventilated room. Keep out of reach of small children. Children must not be allowed to suck any part, or pull vinyl bag over the head.



Před započítím stavby si pečlivě prostudujte stavební návod. Při používání barev a lepidel pracujte v dobře větrané místnosti. Lepidla ani barvy nepoužívejte v blízkosti otevřeného ohně. Model není určen malým dětem, mohlo by dojít k požití drobných dílů.

INSTRUCTION SIGNS \* INSTR. SYMBOLS \* INSTRUKTION SINNBILDEN \* SYMBOLES \* 記号の説明

OPTIONAL  
VOLBABEND  
OHNOUTSAND  
BROUSITOPEN HOLE  
VYVRTAT OTVORSYMETRICAL ASSEMBLY  
SYMETRICKÁ MONTÁŽREMOVE  
ODŘÍZNOUTREVERSE SIDE  
OTOČITAPPLY EDUARD MASK  
AND PAINT  
POUŽIT EDUARD MASK  
NABARVIT

PARTS



DÍLY



TEILE



PIÈCES



部品

PLASTIC PARTS

A&gt;

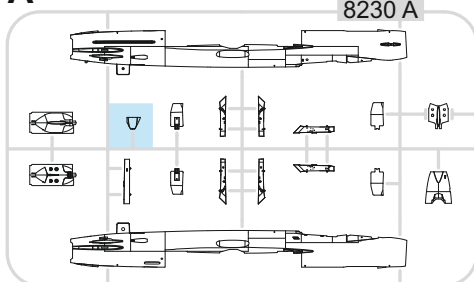

B&gt;

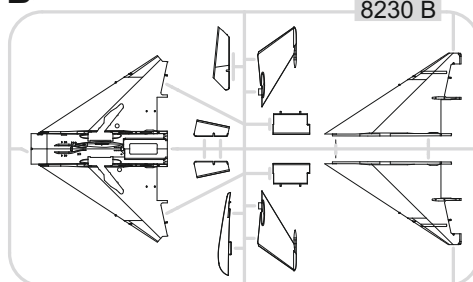

C&gt;

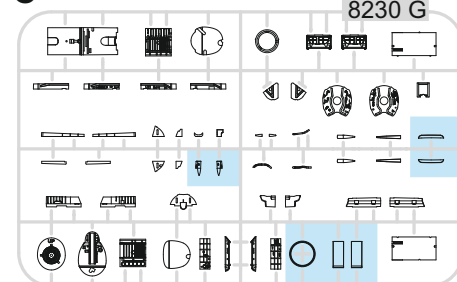

D&gt;

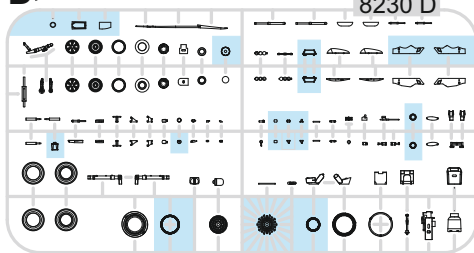

E&gt; 2 pcs.

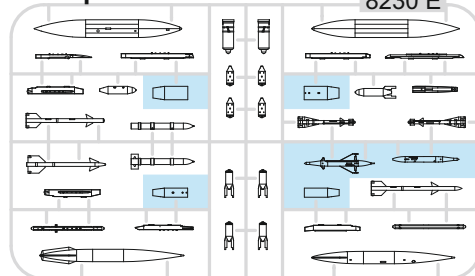

F&gt;

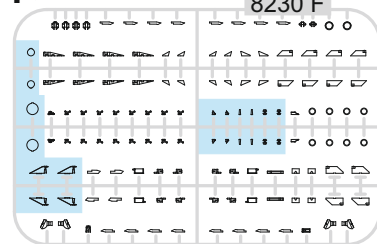

G&gt;

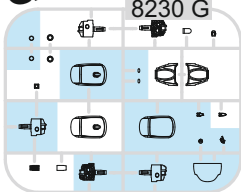

J&gt;

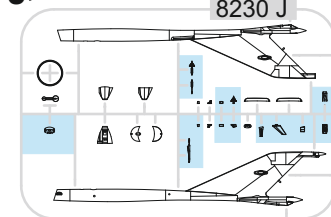

RP - RESIN PARTS



R10 R11

-Parts not for use. -Teile werden nicht verwendet. -Pièces à ne pas utiliser. -Tyto díly nepoužívejte při stavbě. - 使用しない部品

COLOURS



BARVY



FARBEN



PEINTURE



色

GSI Creos (GUNZE)		MISSION MODELS	
AQUEOUS	Mr.COLOR	PAINTS	
H1	C1	MMP-001	WHITE
H3	C3	MMP-003	RED
H4	C4	MMP-007	YELLOW
H5	C5	MMP-048	BLUE
H7	C7	MMP-002	BROWN
H8	C8		SILVER
H11	C62	MMP-001	FLAT WHITE
H12	C33	MMP-047	FLAT BLACK
H26	C66		BRIGHT GREEN
H51	C11	MMP-063	LIGHT GULL GRAY
H53	C13		NEUTRAL GRAY
H66	C119	MMP-119	SAND YELLOW
H67	C115	MMP-057	LIGHT BLUE
H70	C60	MMP-056	GRAY
H72	C369	MMP-078	DARK EARTH
H77	C137	MMP-040	TIRE BLACK
H81	C55	MMP-023	KHAKI
H82	C32		DARK GRAY
H84	C42		MAHOGANY
H90	C47		CLEAR RED

GSI Creos (GUNZE)		MISSION MODELS	
AQUEOUS	Mr.COLOR	PAINTS	
H94	C138		CLEAR GREEN
H302	C302		GREEN
H304	C304	MMP-026	OLIVE DRAB
H308	C308	MMP-073	GRAY
H309	C309	MMP-031	GREEN
H312	C312		GREEN
H318	C318	MMP-070	RADOME
H332	C332		GRAYISH BLUE
H337	C337		LIGHT AIRCRAFT GRAY
	C19		SANDY BROWN
	C131		RED BROWN
	C391		INTERIOR TURQUISE GREEN
	C511		RUSSIAN GREEN
Mr.METAL COLOR		METALLICS	
MC213		MMM-006	STEEL
MC214		MMM-001	DARK IRON
MC218		MMM-003	ALUMINIUM
Mr.COLOR SUPER METALLIC		METALLICS	
SM206		MMC-001	CHROME SILVER

- 1** = 

H11 MMP	- MARKING C
C62 001	FLAT WHITE
H51 MMP	- MARKING A
C11 063	LIGHT GULL GRAY
H70 MMP	- MARKING D
C80 056	GRAY
H308 MMP	- MARKING B
C308 073	GRAY

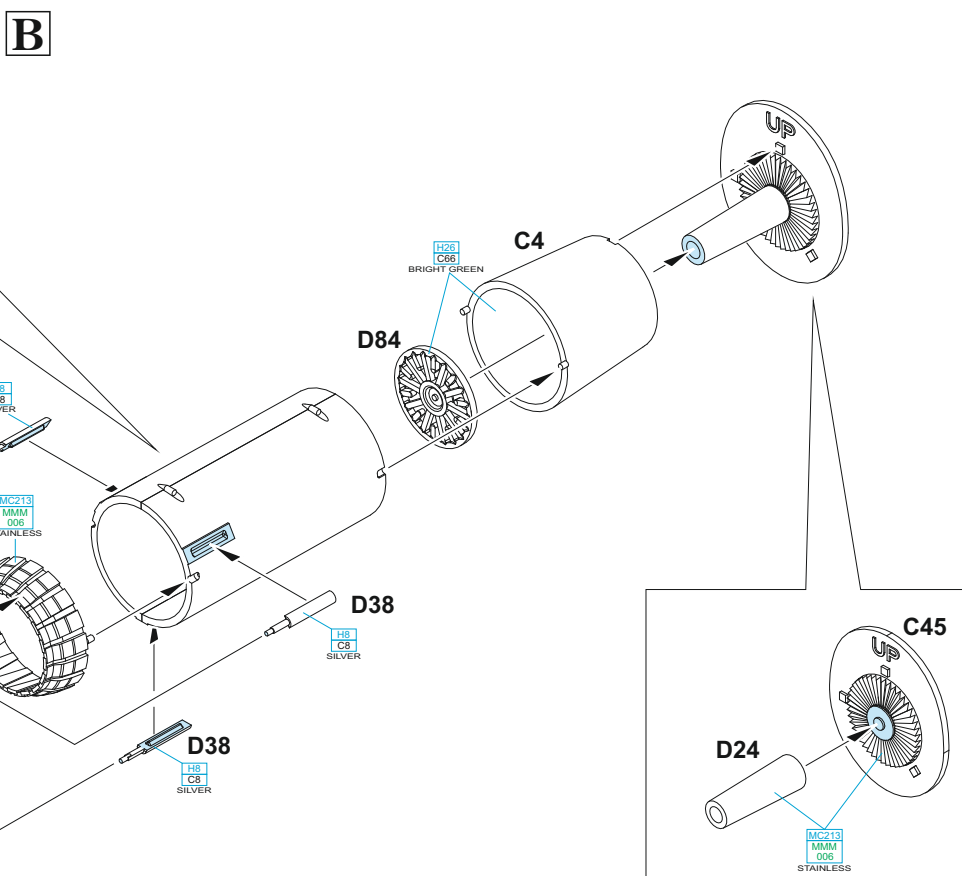
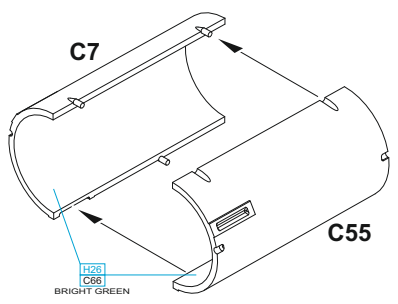
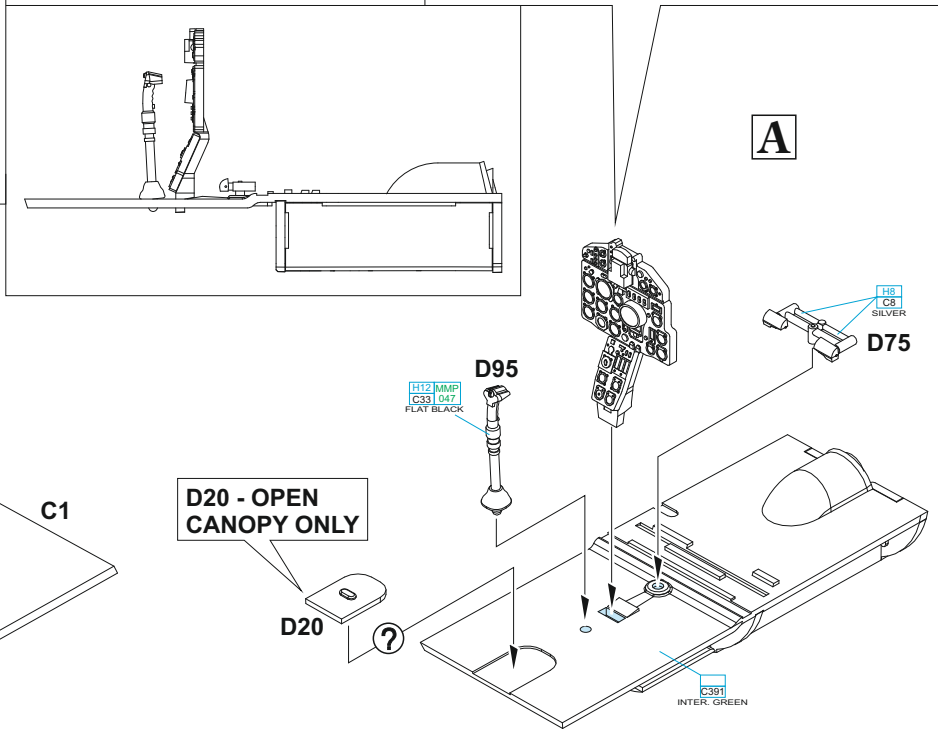
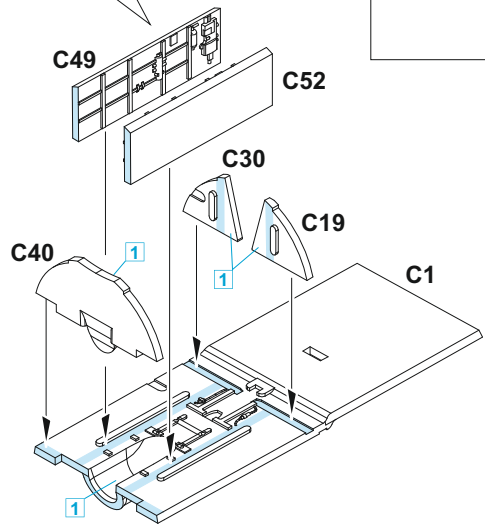
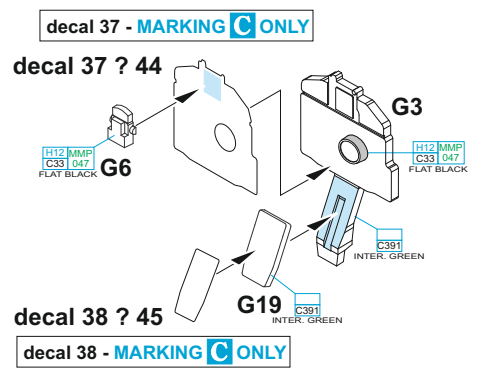
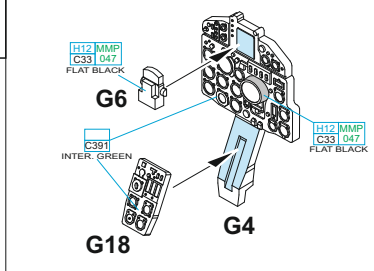
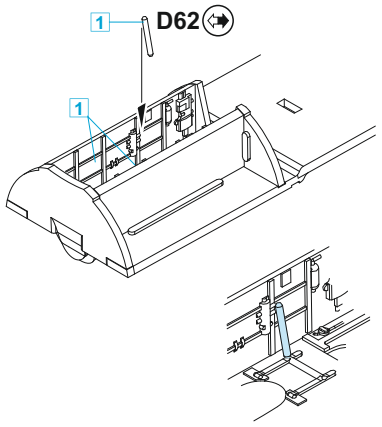

**C**

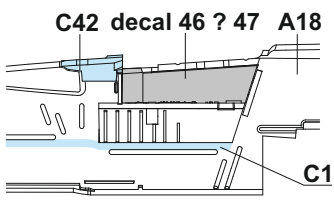
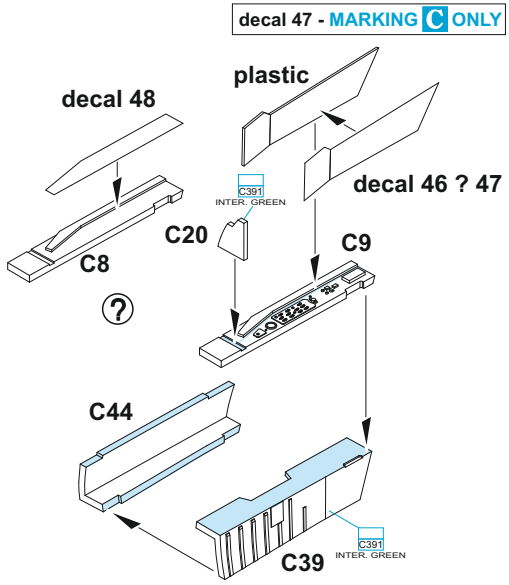
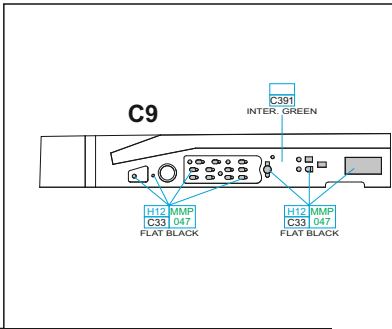
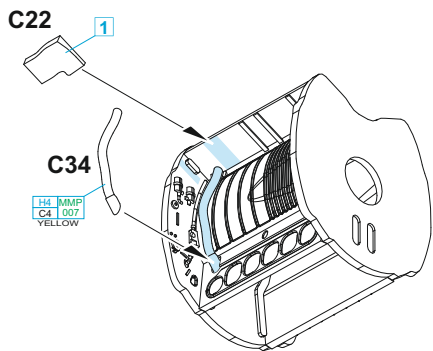
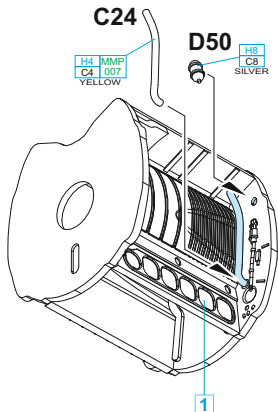
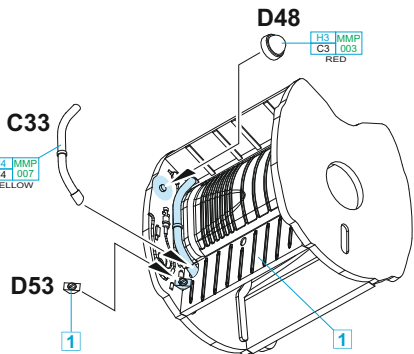
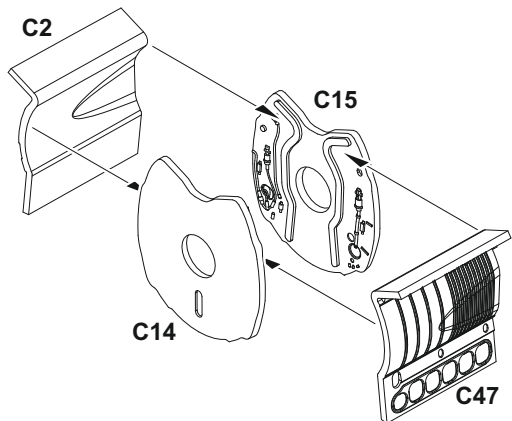

**D**

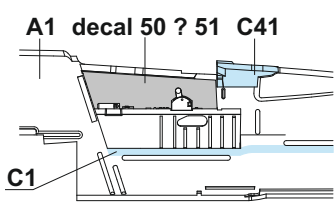
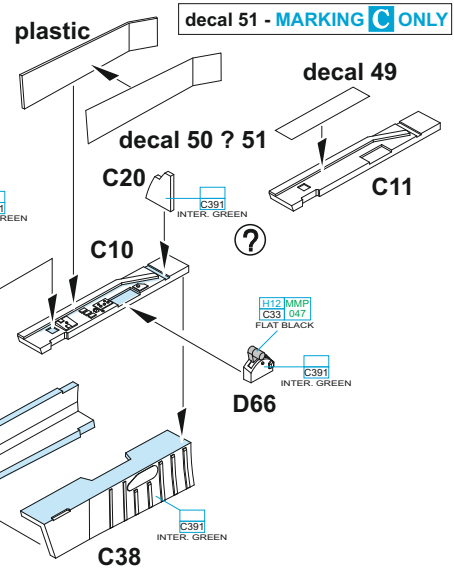
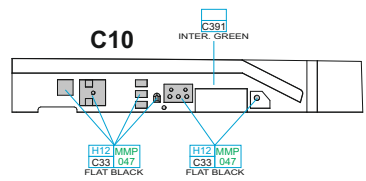
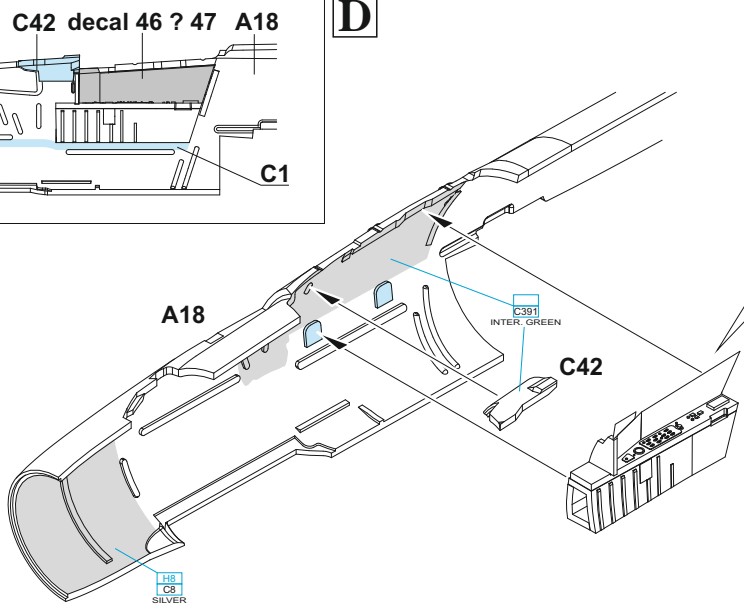

**E**

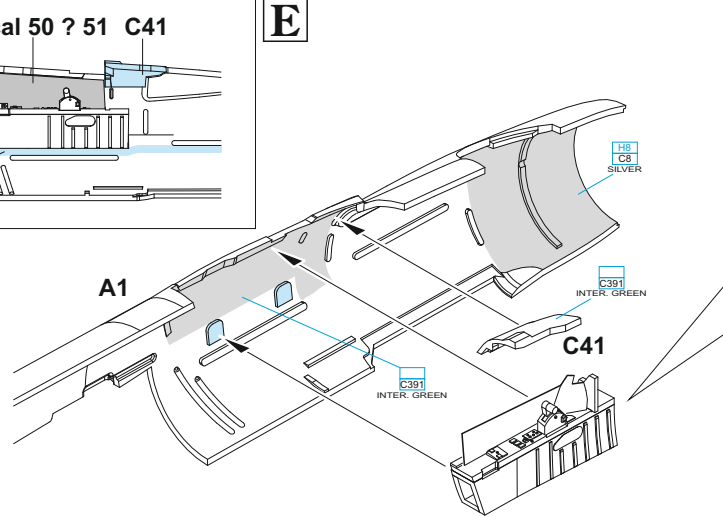

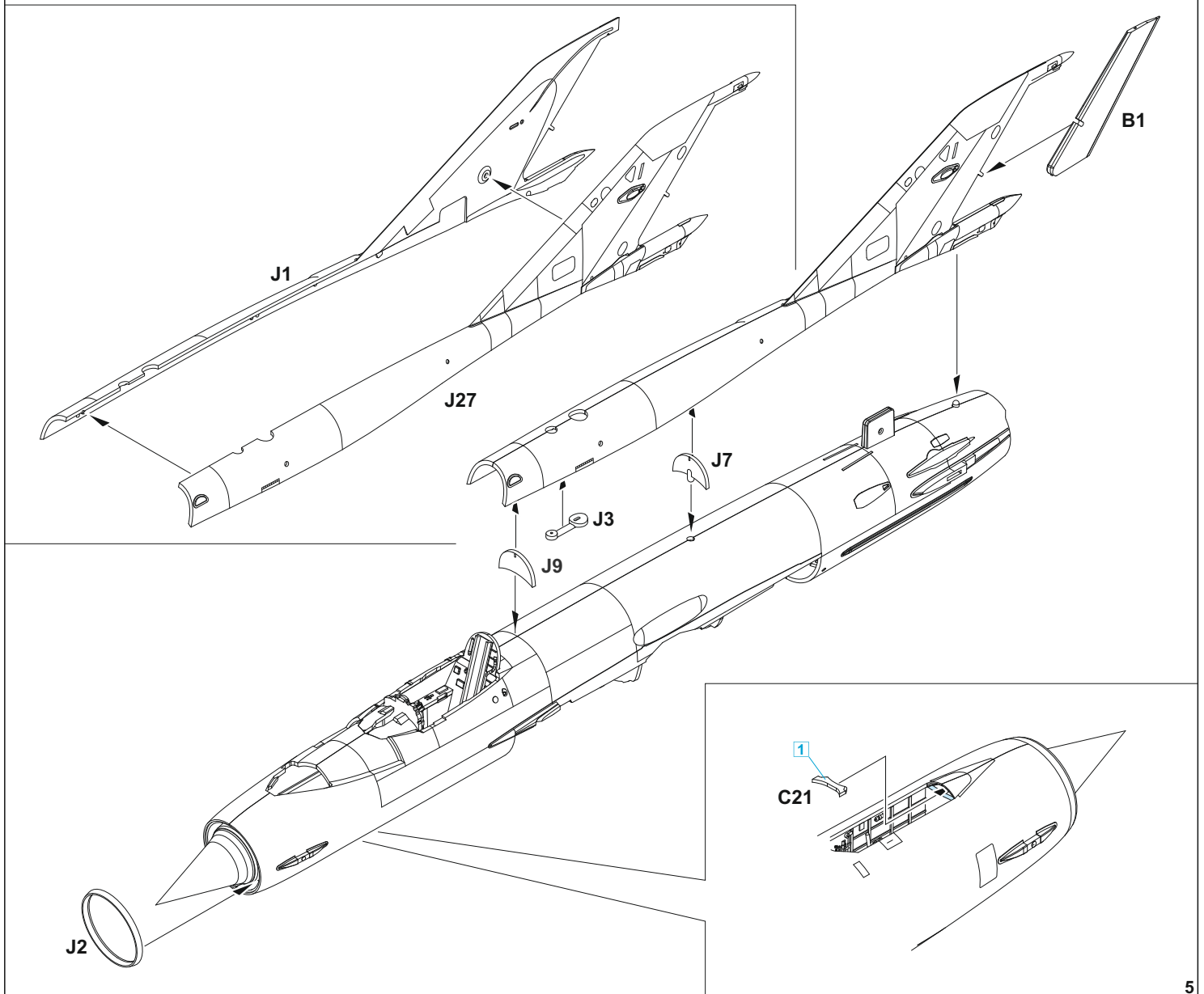
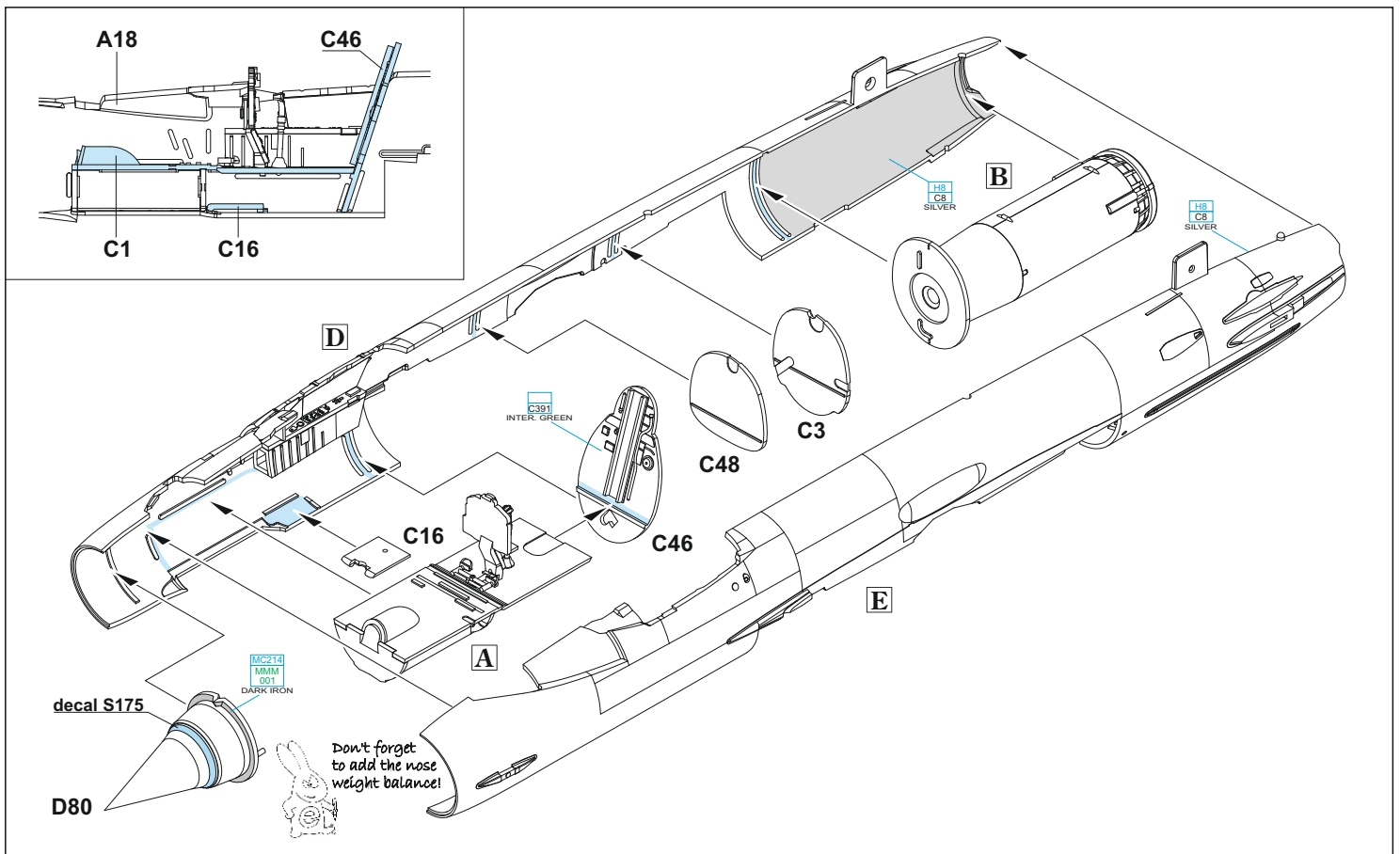

FOR OPEN AIR BRAKES ONLY

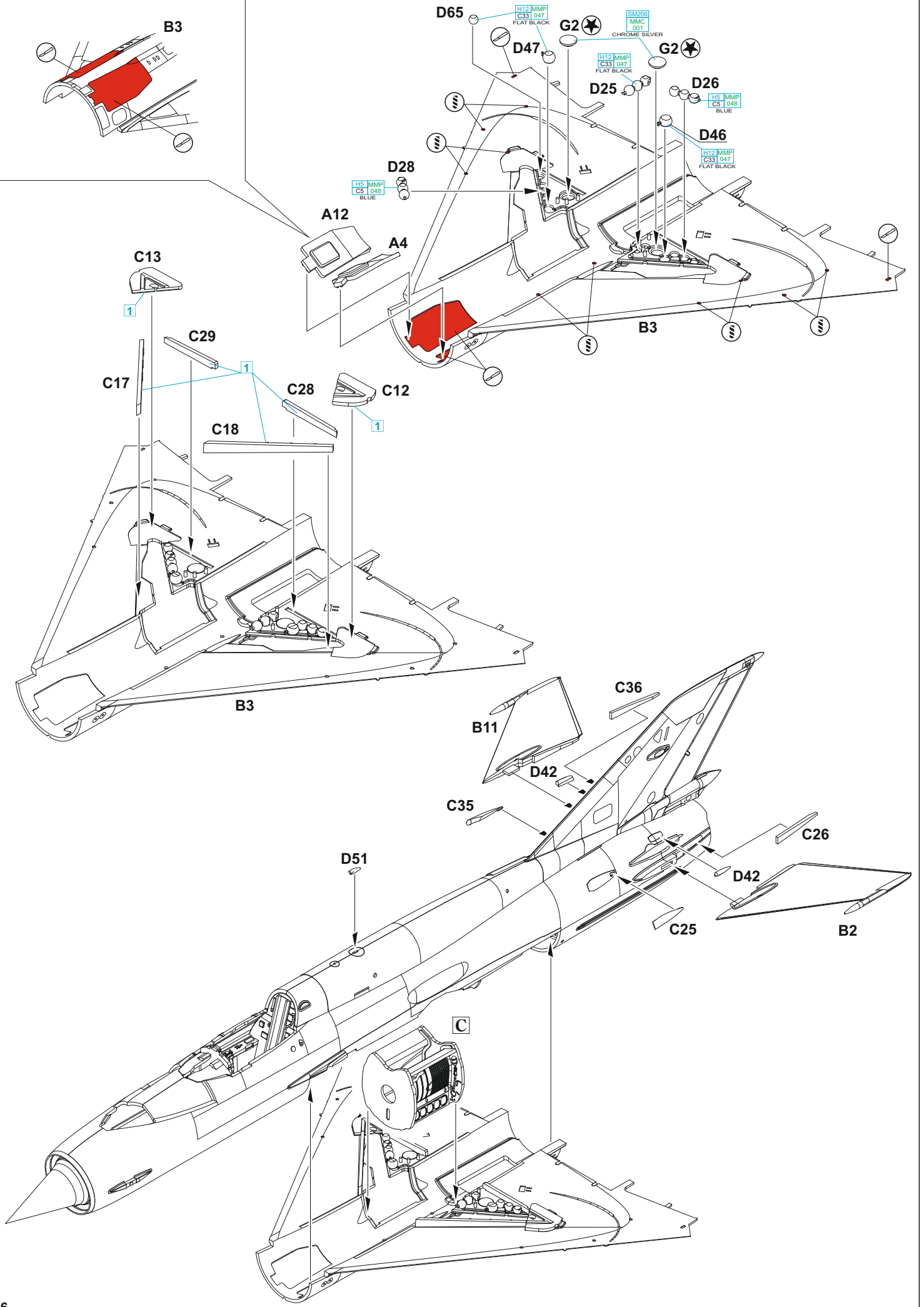

**2** = H51 MMP  
C11 063 - MARKINGS **A;D**  
LIGHT GULL GRAY

F308 MMP  
G308 073 - MARKING **B**  
GRAY

F337  
G337 - MARKING **C**  
GRAYISH BLUE

**3** = H67 MMP  
C115 057 - MARKING **A**  
LIGHT BLUE

F308 MMP  
G308 073 - MARKINGS **B;C**  
GRAY

F337  
G337 - MARKING **D**  
GRAYISH BLUE

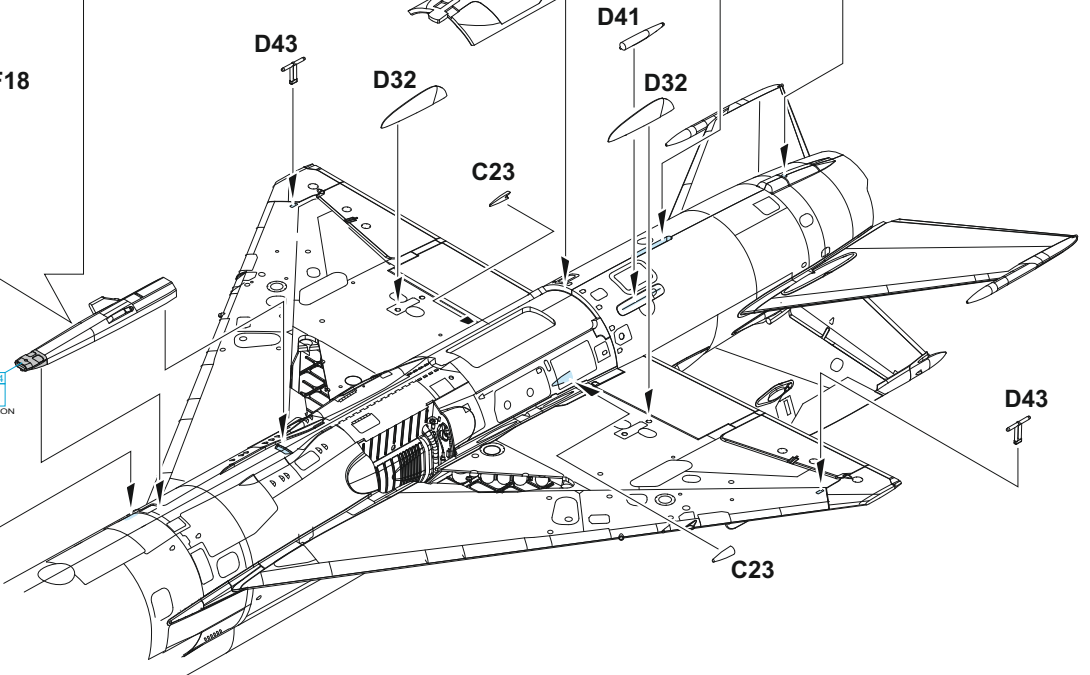
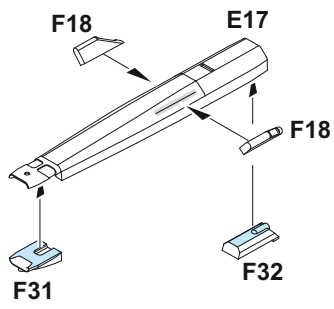
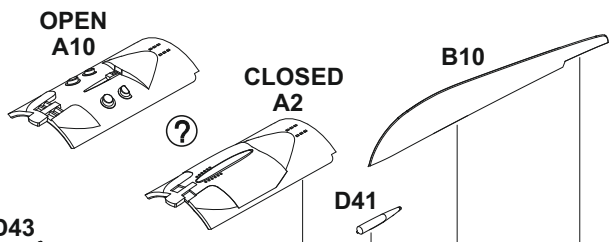
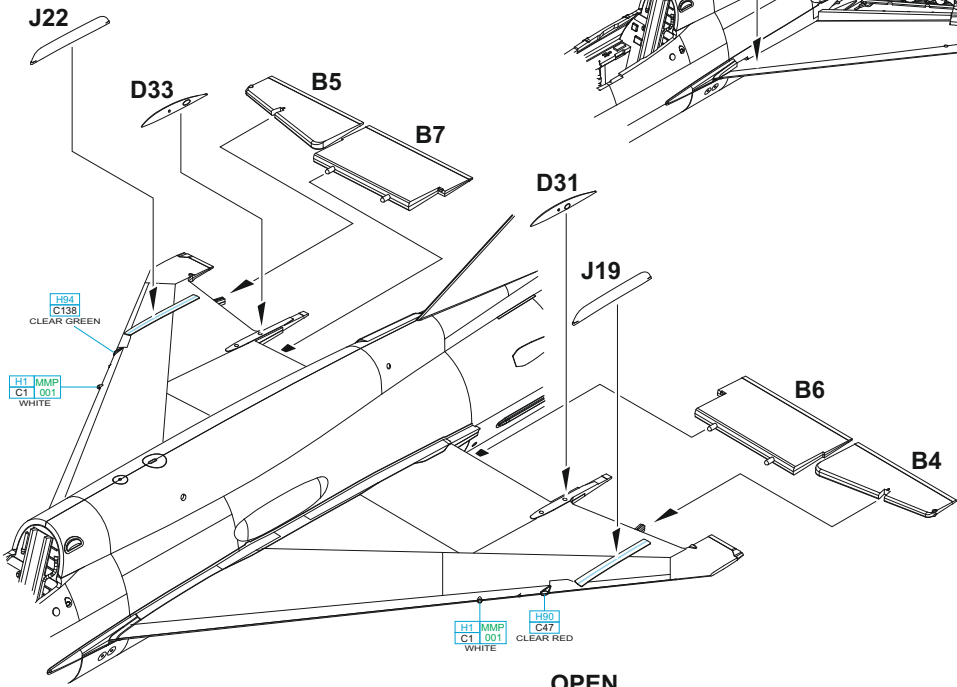
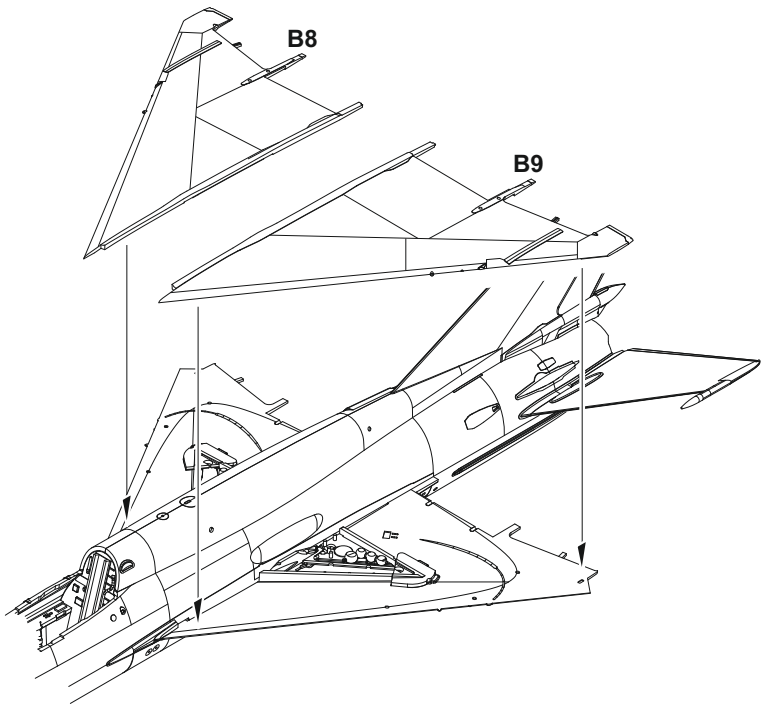

**J13 - MARKING C ONLY**

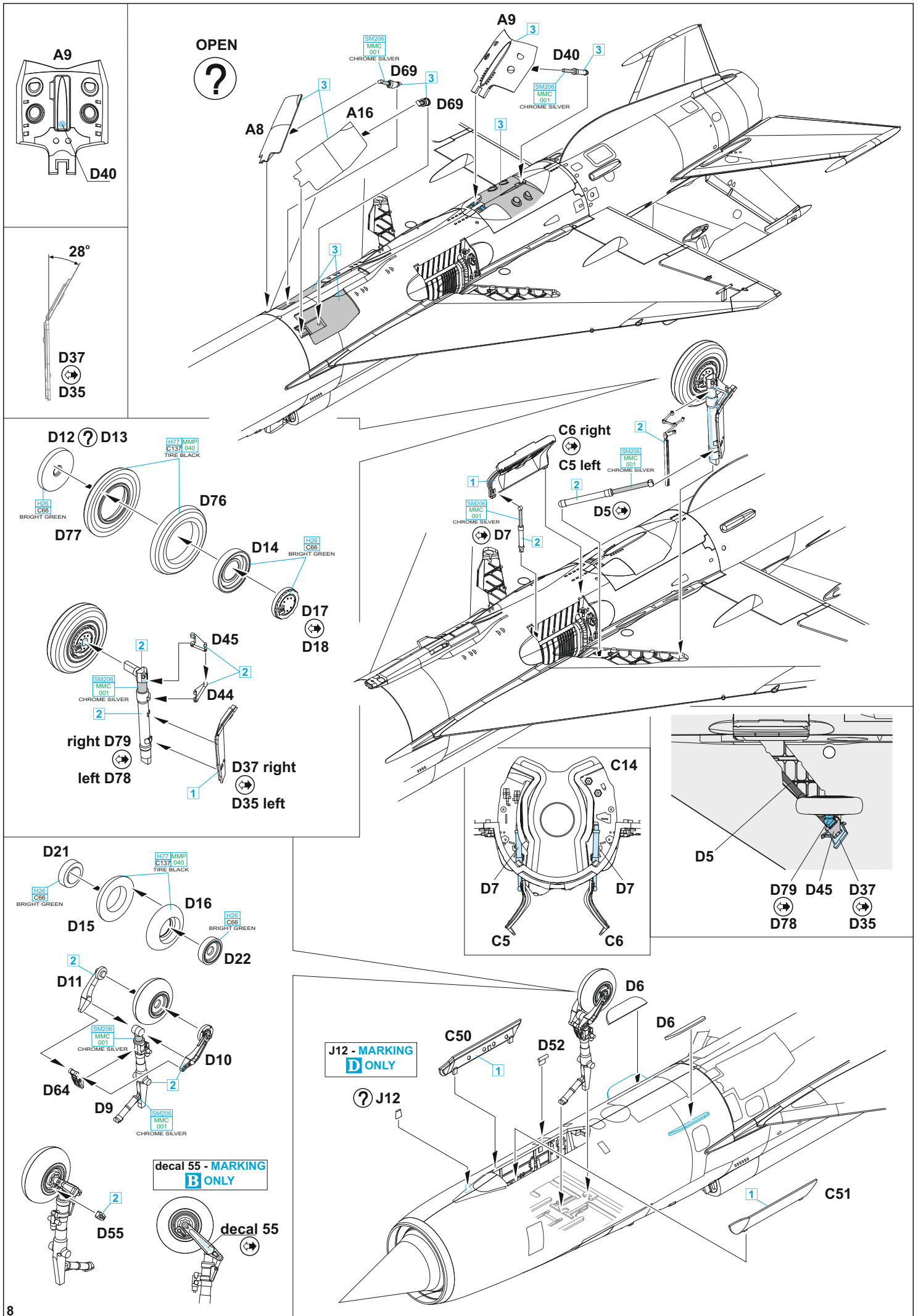

**F**

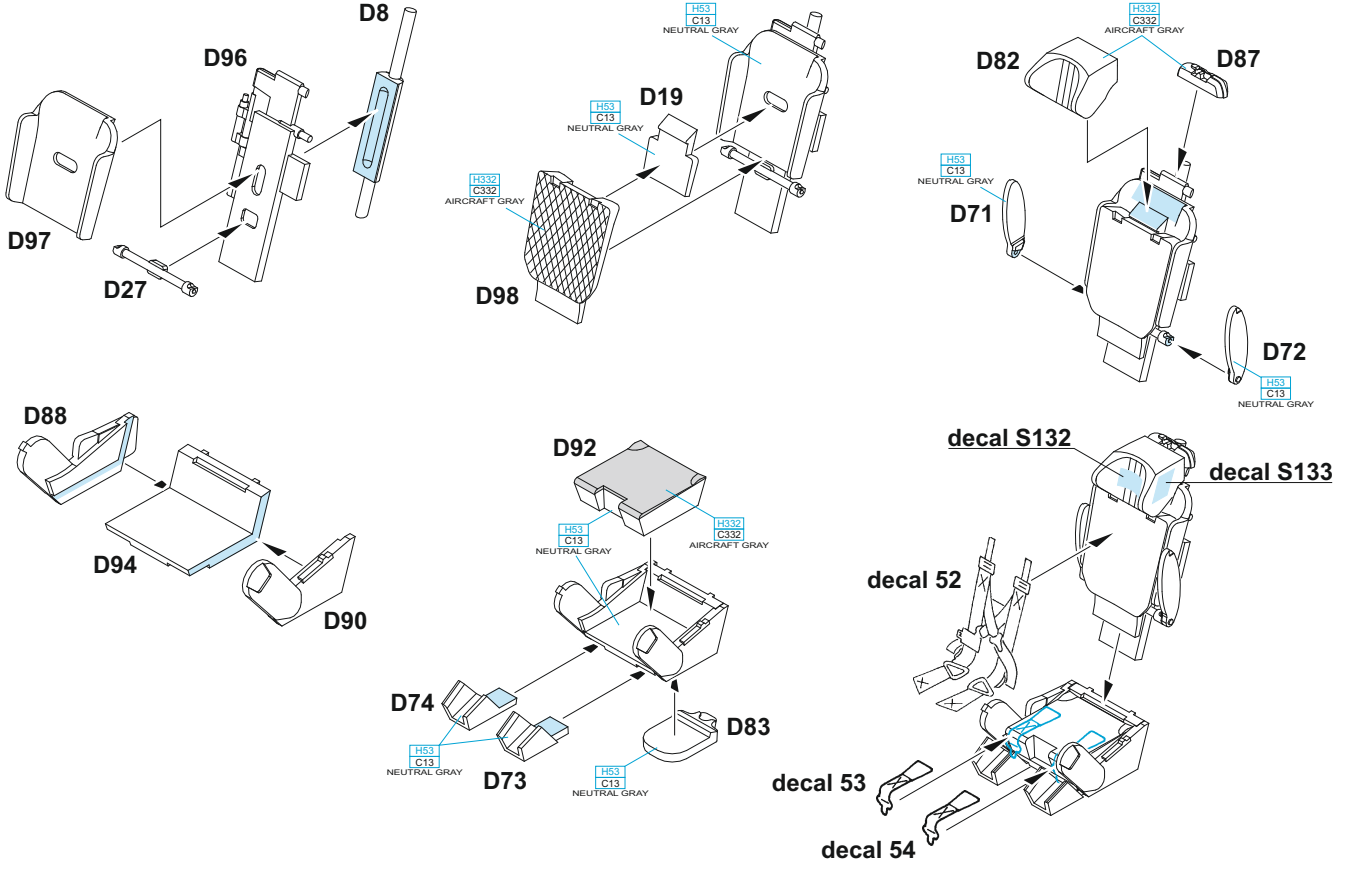

**G**

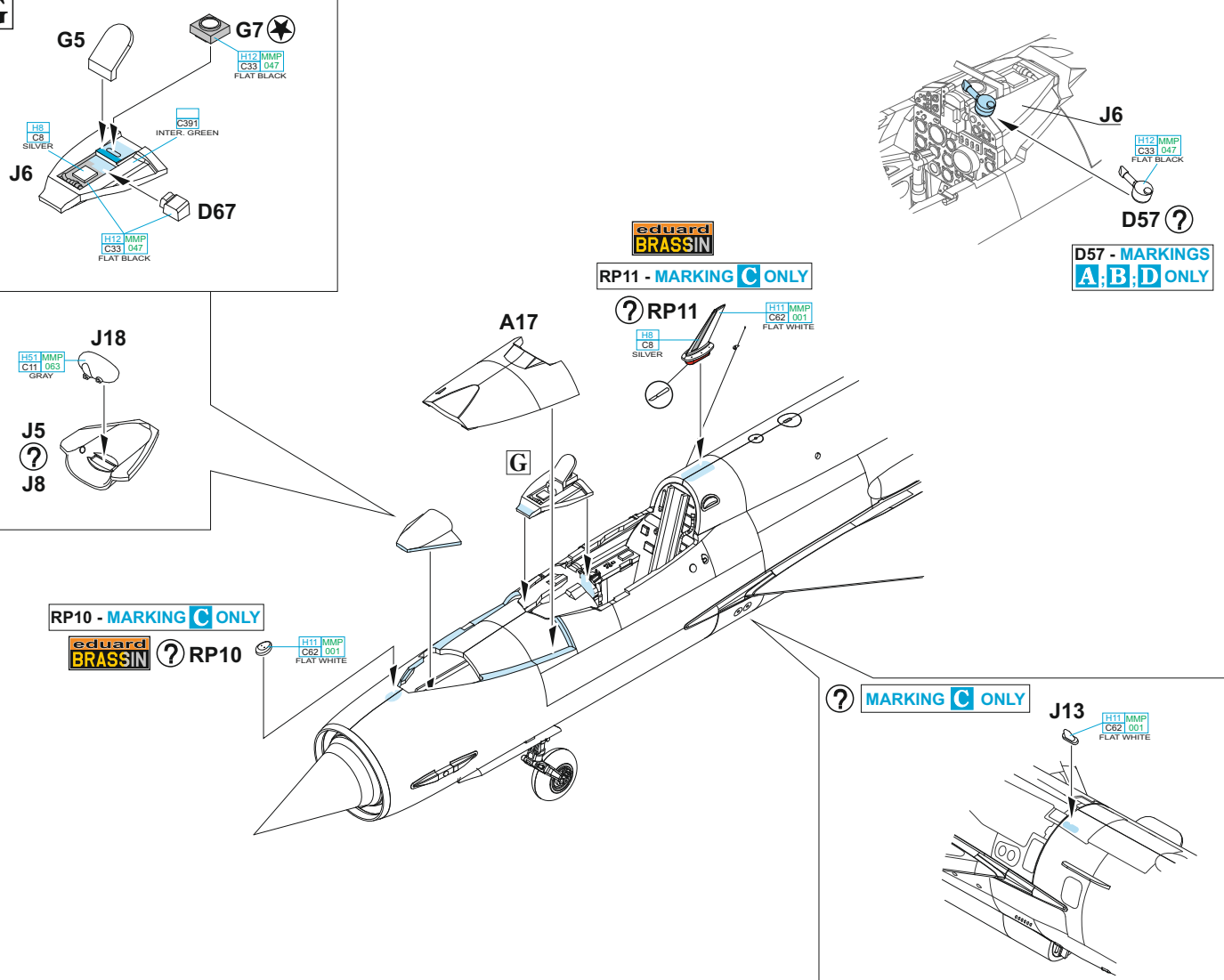

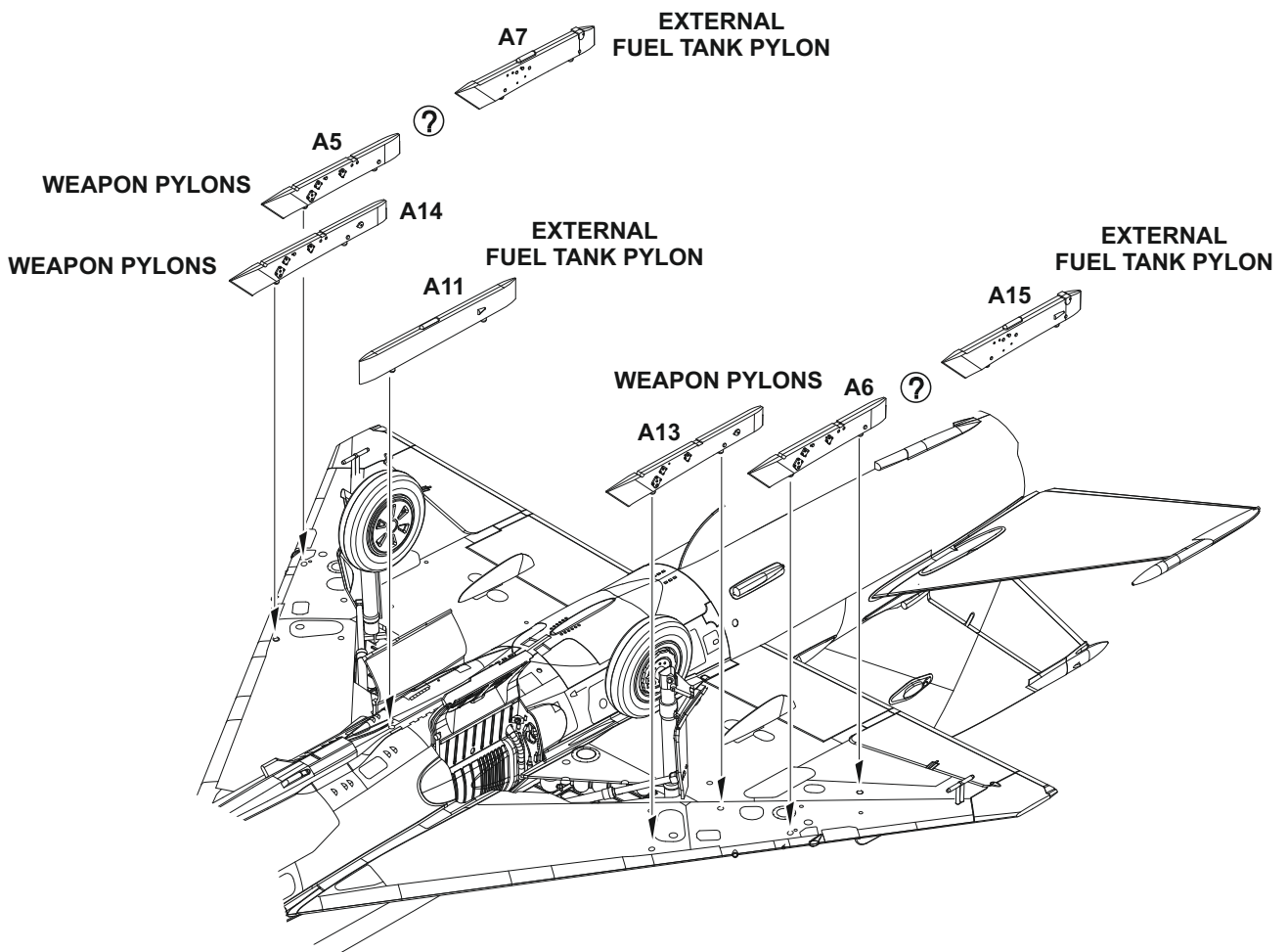
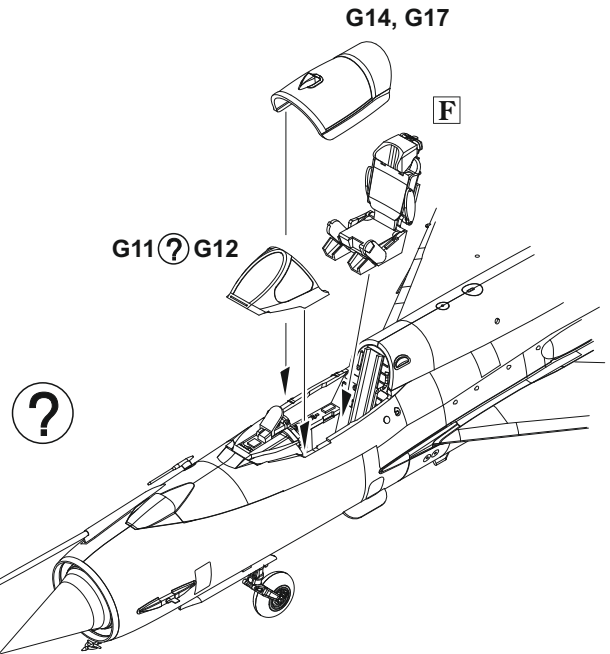
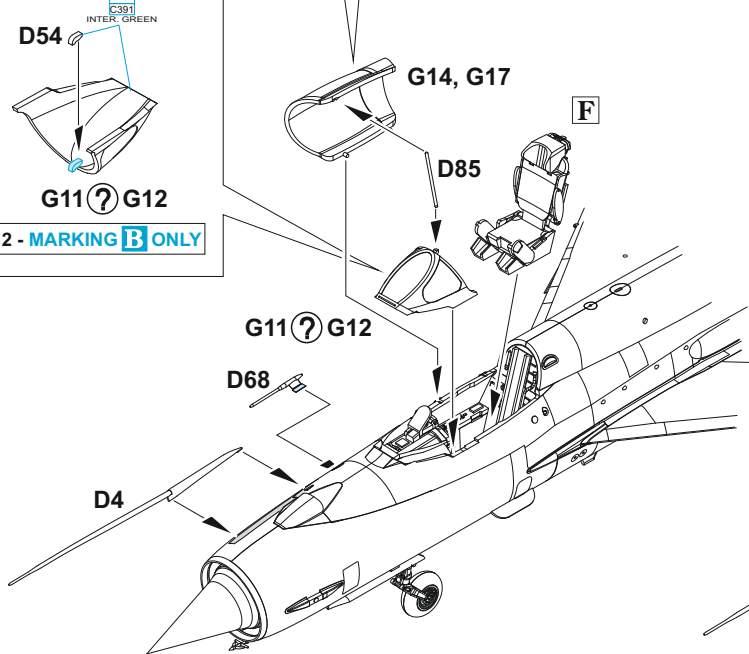
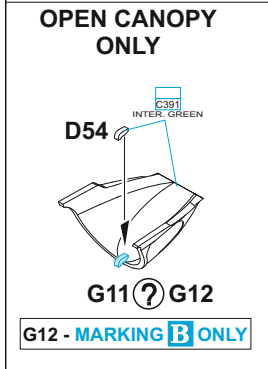
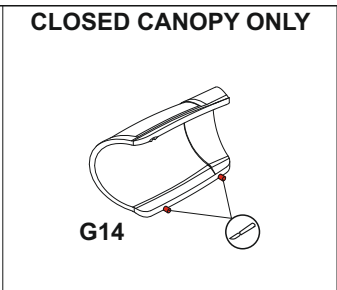
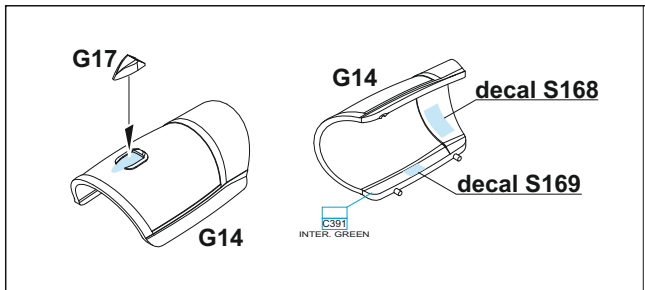

**EXTERNAL FUEL TANK 800I**

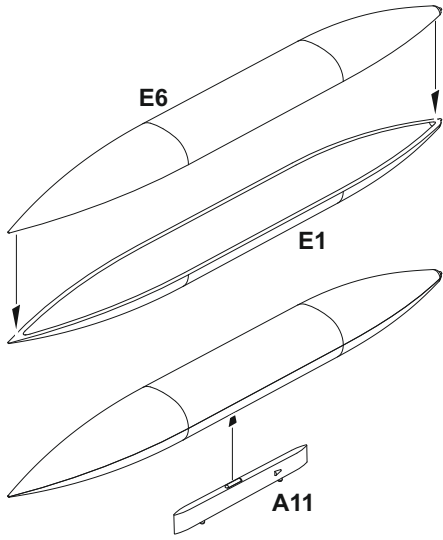

**EXTERNAL FUEL TANK 490I**  
2 sets

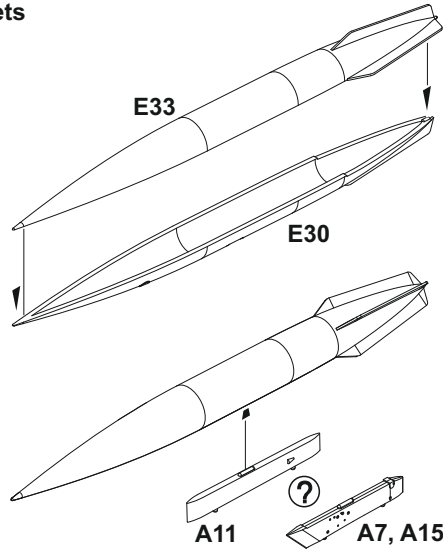

**S-24**  
2 sets

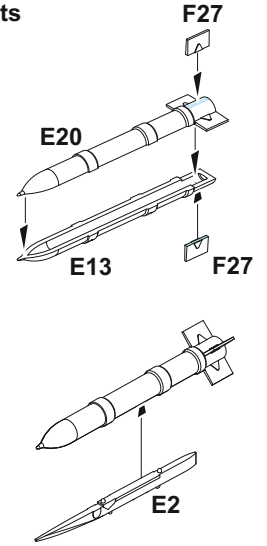

**R-3S**  
2 sets

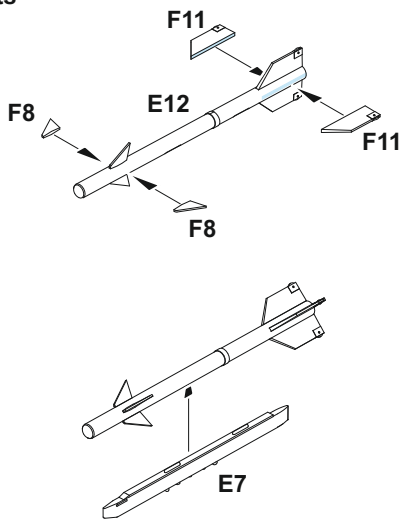

**R-3R**  
2 sets

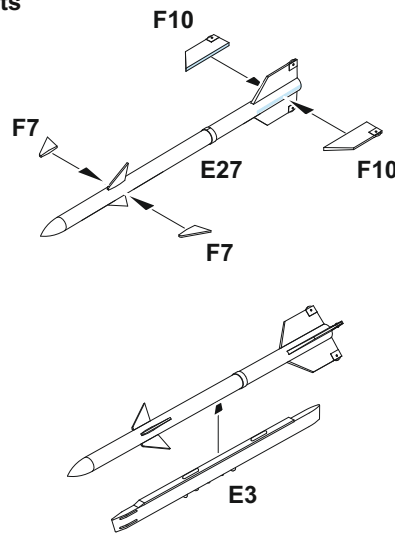

**R-13**  
2 sets

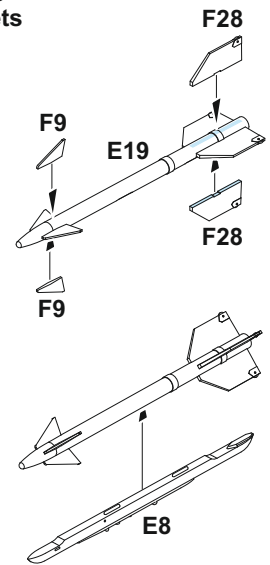

**MBD FOR 4x FAB 100**  
2 sets

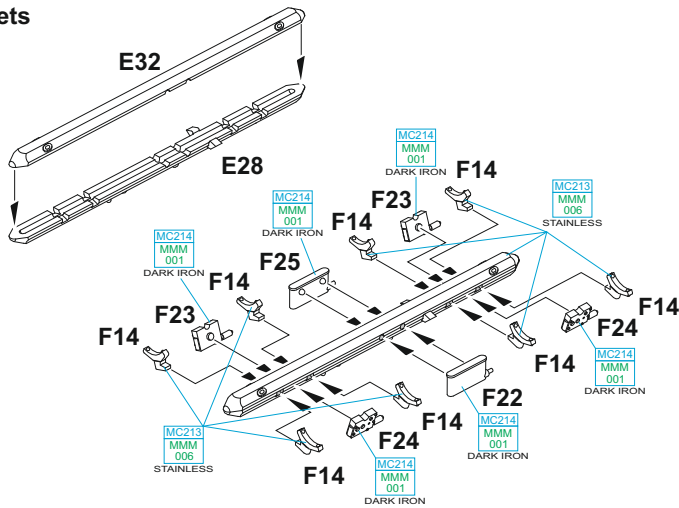

**R-60**  
2 sets

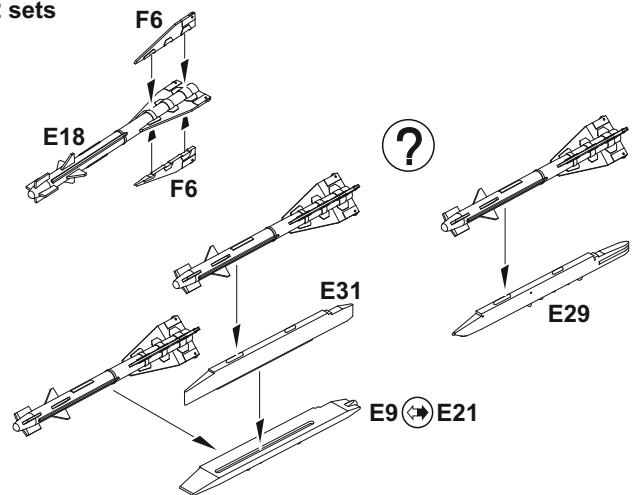

**FAB 250 BOMB**  
2 sets

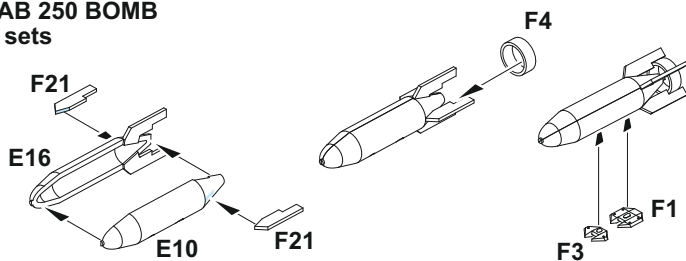

**FAB 100 BOMB**  
8 sets

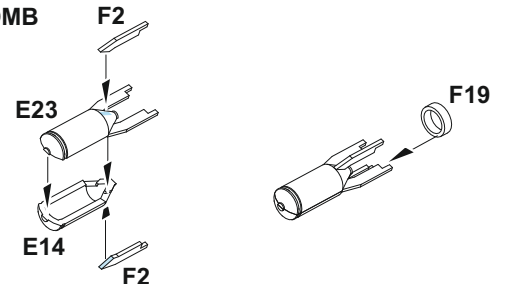

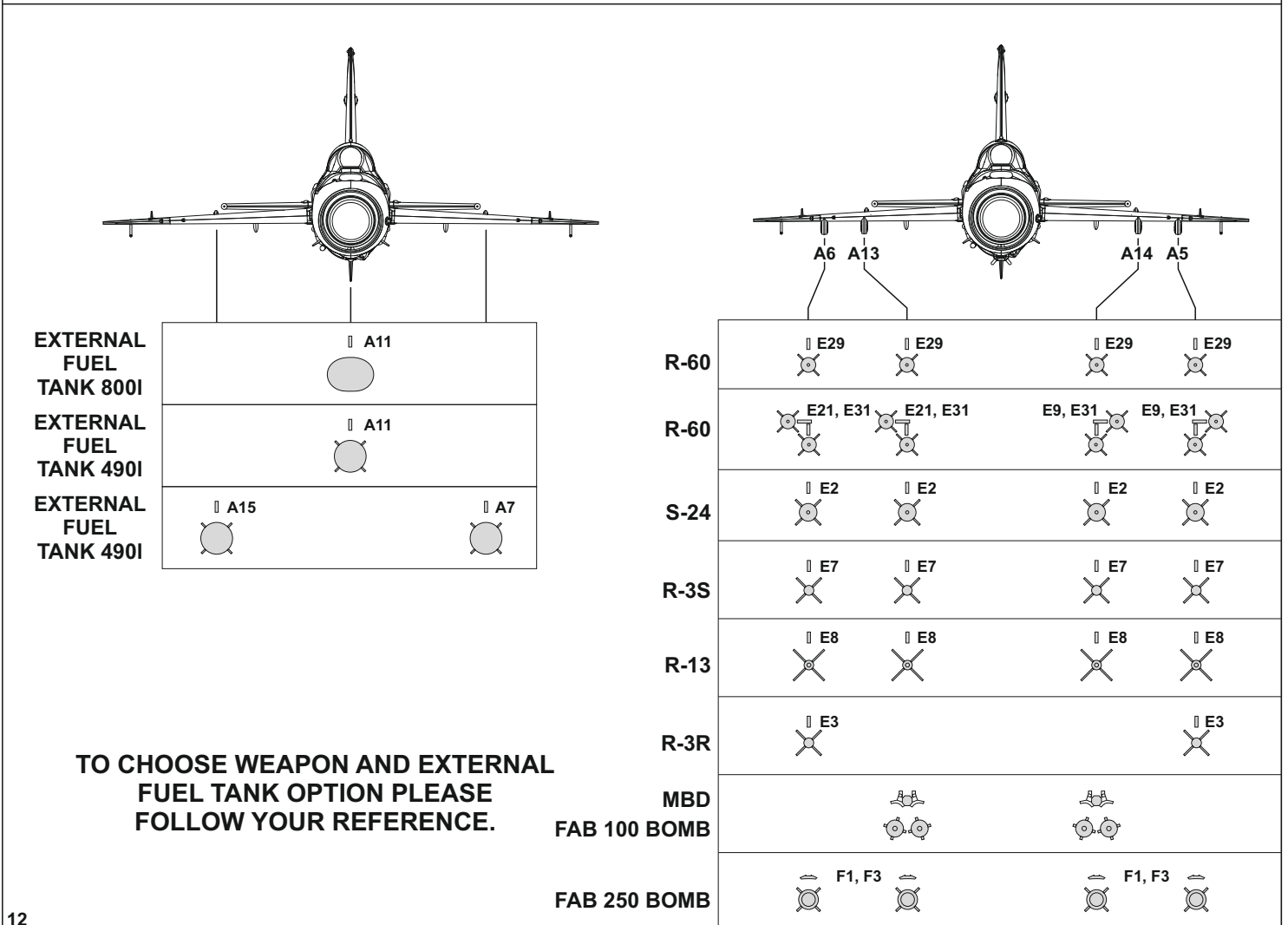
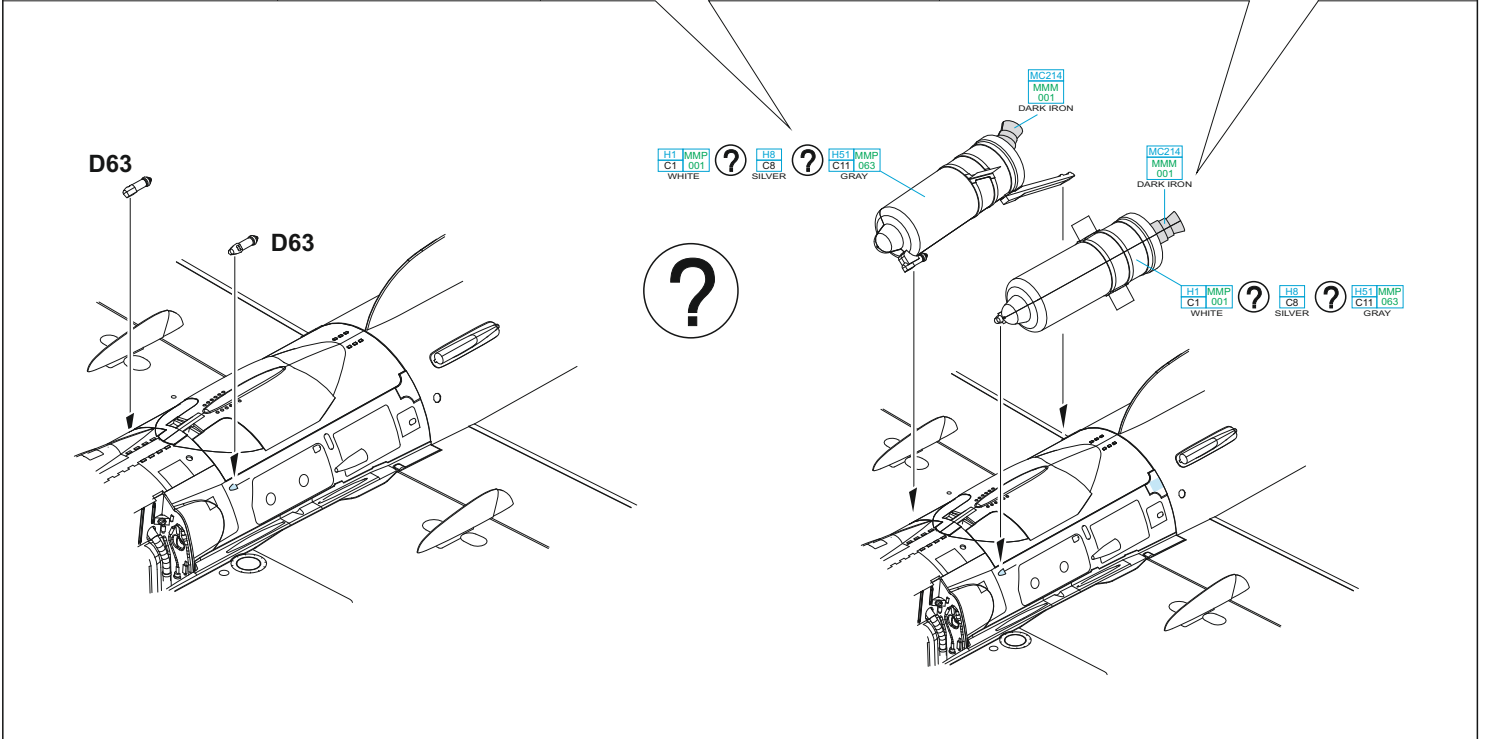
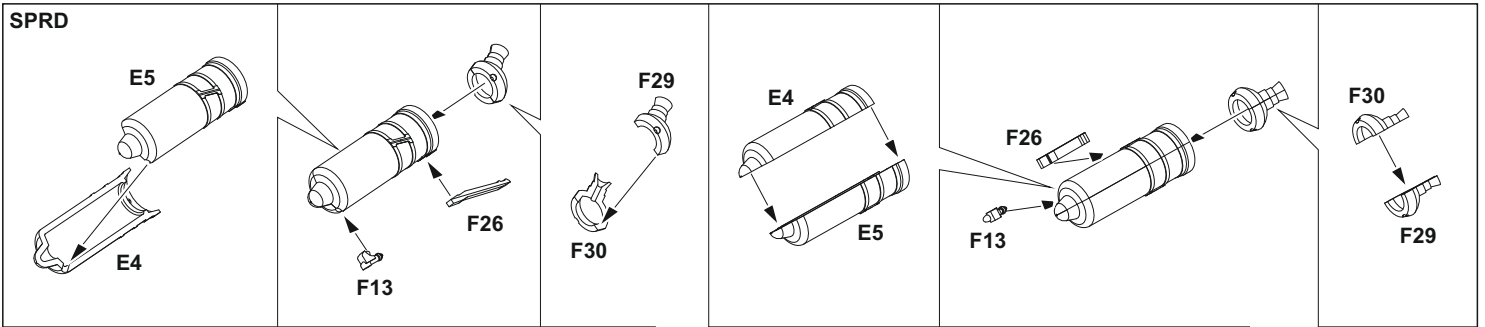

# A MiG-21bis, 115<sup>th</sup> GIAP, Soviet VVS, Bagram Air Base, Afghanistan, 1980

Fighter cover duties during the Soviet invasion of Afghanistan were conducted by the 115<sup>th</sup> Guards' Regiment at the end of 1979. The unit was equipped with the MiG-21bis and was based at Kokoity in Uzbekistan, a Soviet Socialist State at the time. Three days after the invasion beginning, the 1<sup>st</sup> Squadron moved to Bagram Air Base, followed by a second Squadron on January 23, 1980. Due to the lack of any enemy fighters, the 115<sup>th</sup> GIAP became involved in ground support duties together with the 136<sup>th</sup> APIB. MiG-21bis aircraft of the 115<sup>th</sup> GIAP used in Afghanistan were painted in green and brown on the upper surfaces at the beginning of the war, with lower surfaces in a blue-grey tone.

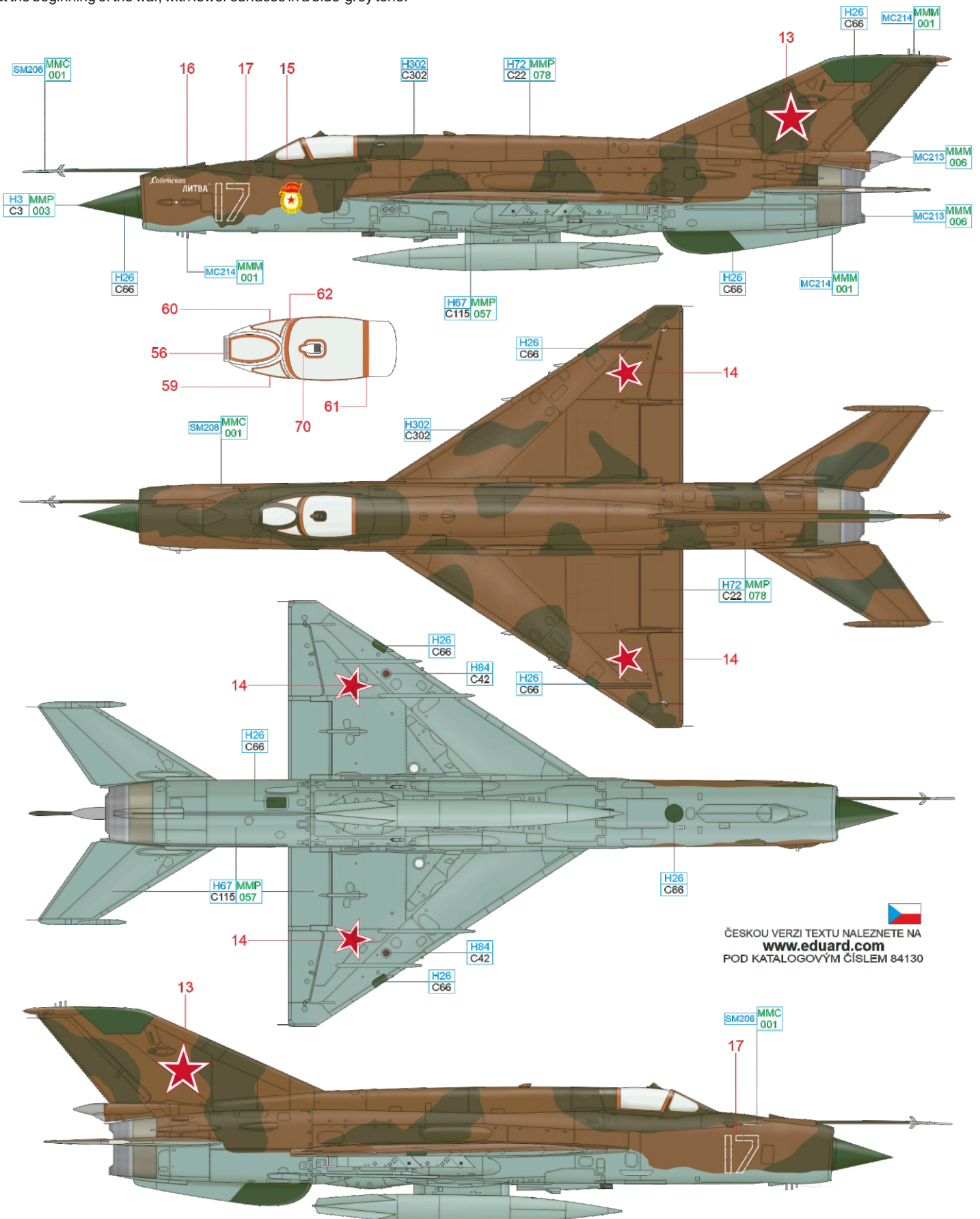

ČESKOU VERZI TEXTU NALEZNETE NA  
[www.eduard.com](http://www.eduard.com)  
 POD KATALOGOVÝM ČÍSLEM 84130

LIGHT BLUE	H67 MMP C115 057	BRIGHT GREEN	H26 C66	LIGHT BROWN	C19	MAHOGANY	H84 C42
DARK EARTH	H72 MMP C369 078	GREEN	H302 C302	RED	H3 MMP C3 003	CHROME SILVER	SM206 MMC 001
						DARK IRON	MC214 MMM 001
						STEEL	MC213 MMM 006



# C MiG-21bisD, Eskadrila borbenih aviona, HRZ i PZO, Zagreb – Pleso, Croatia, December 2016

The Croatian Air Force purchased forty MiG-21bis fighters and MiG-21UM trainers from Ukraine in 1995. In 2003, eight MiG-21bis aircraft were modernized to bisD standard in Romania. The modernization program included upgrade of the navigation, communication and IFF equipment. In 2014, another modernization took place involving seven Croat MiG-21bisD/UMD aircraft, along with a purchase of another five aircraft from repair facility in Odessa. The modernized aircraft received an all-grey camouflage scheme. Aircraft coded 116 received a stylized "25" on the left side of the fin to commemorate 25<sup>th</sup> anniversary of the Croatian Air Force.

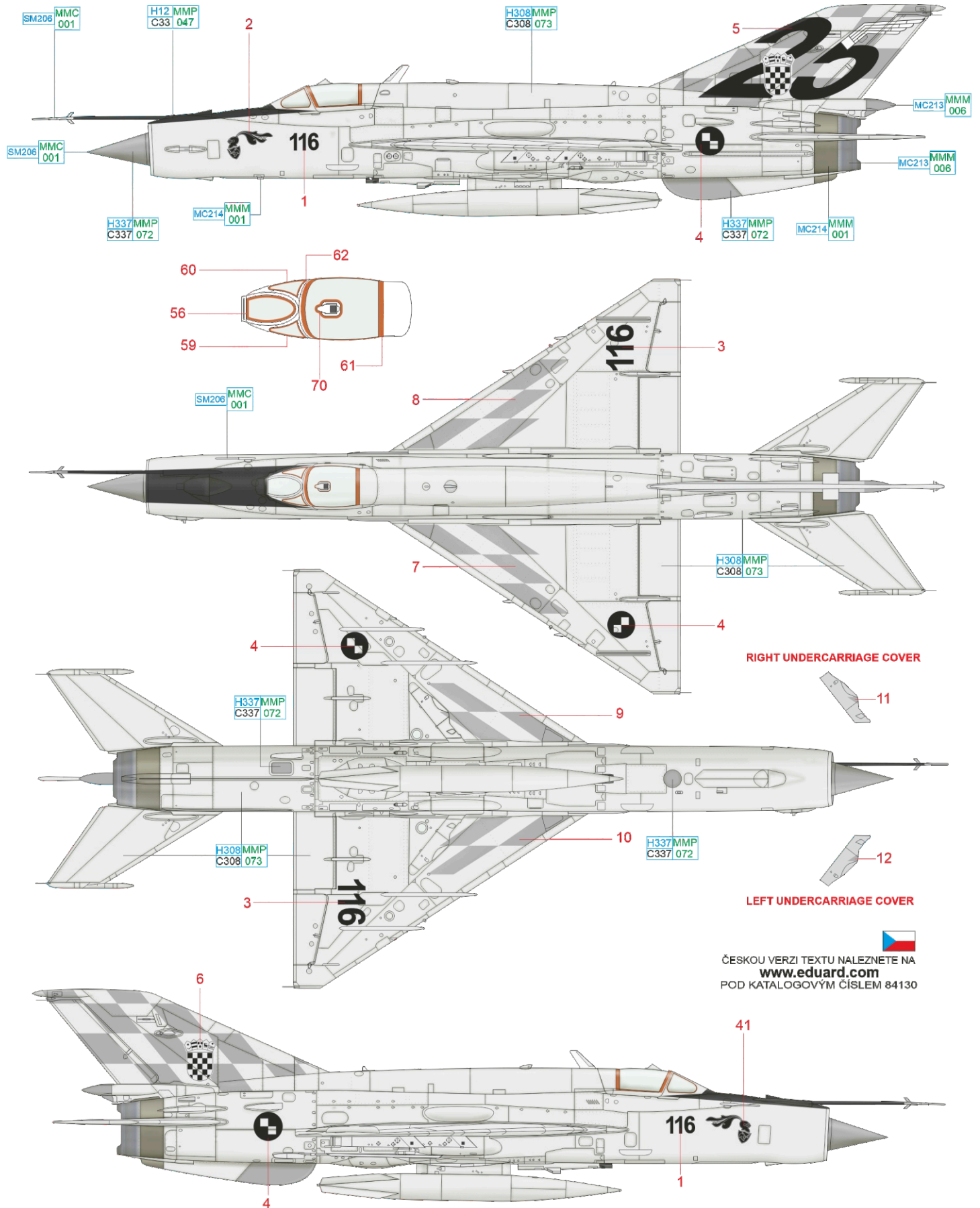

RIGHT UNDERCARRIAGE COVER

LEFT UNDERCARRIAGE COVER

ČESKOU VERZI TEXTU NALEZNETE NA  
[www.eduard.com](http://www.eduard.com)  
 POD KATALOGOVÝM ČÍSLEM 84130

- GRAY H308 MMP C308 073
- GRAY H337 MMP C337 072
- BLACK H12 MMP C33 047
- CHROME SILVER SM206 MMC 001
- DARK IRON MC214 MMM 001
- STEEL MC213 MMM 006
- LIGHT BROWN C19



# D MiG-21bis, C2283, No.3 Squadron „Cobras“, Pathankot AB, India, early '90s

C2283 displays a unique combination of camouflage scheme and colorful ID markings. The unit personnel named their aircraft after snakes, among which "Rattler", "Mamba" and "Cobra" are known. The dorsal section of the fuselage was taken from another MiG-21bis, probably from a "Mamba". The history of No.3 Squadron goes back to October 1941, when the unit was activated in Peshawar, equipped with the Hawker Audaux. During the second half of the Twentieth Century, the unit took part in every conflict that India was involved in with neighboring states. The No.3 Squadron used the MiG-21bis from July 1980 to 2002, when it was re-equipped with the modernized MiG-21 "Bison".



LEVÝ  
VNĚJŠÍ PODKŘÍDLOVÝ  
PALIVOVÝ  
LEFT OUTSIDE  
UNDERWING TANK PYLON

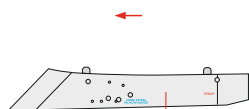

S107

**SN - SERIOVÁ ČÍSLA**  
MALÉ NA DRÁK LETOUNU  
STŘEDNÍ NA ZÁVĚSNÍKY  
VELKÉ NA RAKETNICE

**SN - SERIAL NUMBER**  
SMALL FOR AIRFRAME  
MEDIUM FOR PYLONS  
LARGE FOR ROCKET LAUNCHERS

← PODTRUPOVÝ PYLON →  
FUSELAGE PYLON



S105



S106

PRÁVÝ  
VNĚJŠÍ PALIVOVÝ  
PYLON  
RIGHT OUTSIDE  
UNDERWING TANK PYLON



S108

LEVÝ VNĚJŠÍ PYLON  
LEFT OUTSIDE PYLON

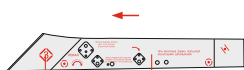

S17 ? S33 S109



S110

PRÁVÝ VNĚJŠÍ PYLON  
RIGHT OUTSIDE PYLON

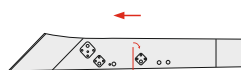

S110



S120 S17 ? S33

LEVÝ VNITŘNÍ PYLON  
LEFT INSIDE PYLON

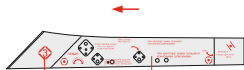

S17 ? S33 S111



S112

PRÁVÝ VNITŘNÍ PYLON  
RIGHT INSIDE PYLON

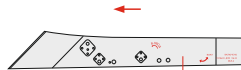

S118



S119 S17 ? S33

## APU-13



S130

S121

S129



S131

S130

SM206  
MMC  
001  
CHROME SILVER

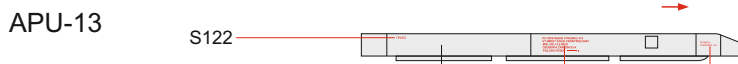

S122

S121

S130



S130

S131

SM206  
MMC  
001  
CHROME SILVER

## APU-13MT

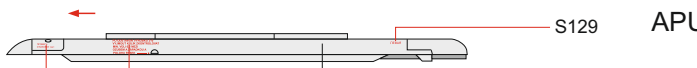

S130

S121

S129



S131

S130

SM206  
MMC  
001  
CHROME SILVER

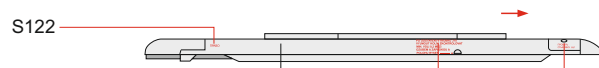

S122

S121

S130



S130

S131

SM206  
MMC  
001  
CHROME SILVER

## APU FOR R-60

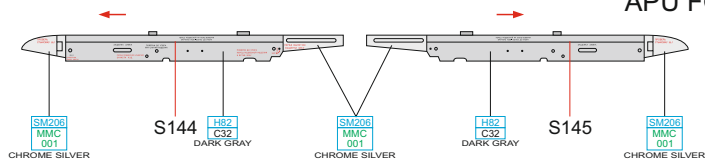

SM206  
MMC  
001  
CHROME SILVER

S144

H82  
C32  
DARK GRAY

SM206  
MMC  
001  
CHROME SILVER

H82  
C32  
DARK GRAY

S145

SM206  
MMC  
001  
CHROME SILVER

SM206  
MMC  
001  
CHROME SILVER

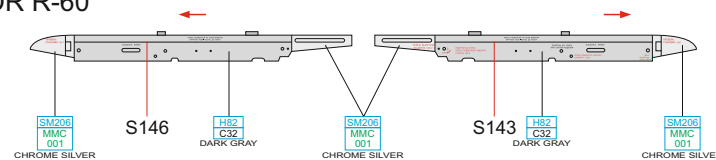

SM206  
MMC  
001  
CHROME SILVER

S146

H82  
C32  
DARK GRAY

SM206  
MMC  
001  
CHROME SILVER

S143

H82  
C32  
DARK GRAY

SM206  
MMC  
001  
CHROME SILVER

## APU-13 FOR R-3R



S130

S121

S129



S131

S130

SM206  
MMC  
001  
CHROME SILVER



S122

S121

S130

SM206  
MMC  
001  
CHROME SILVER



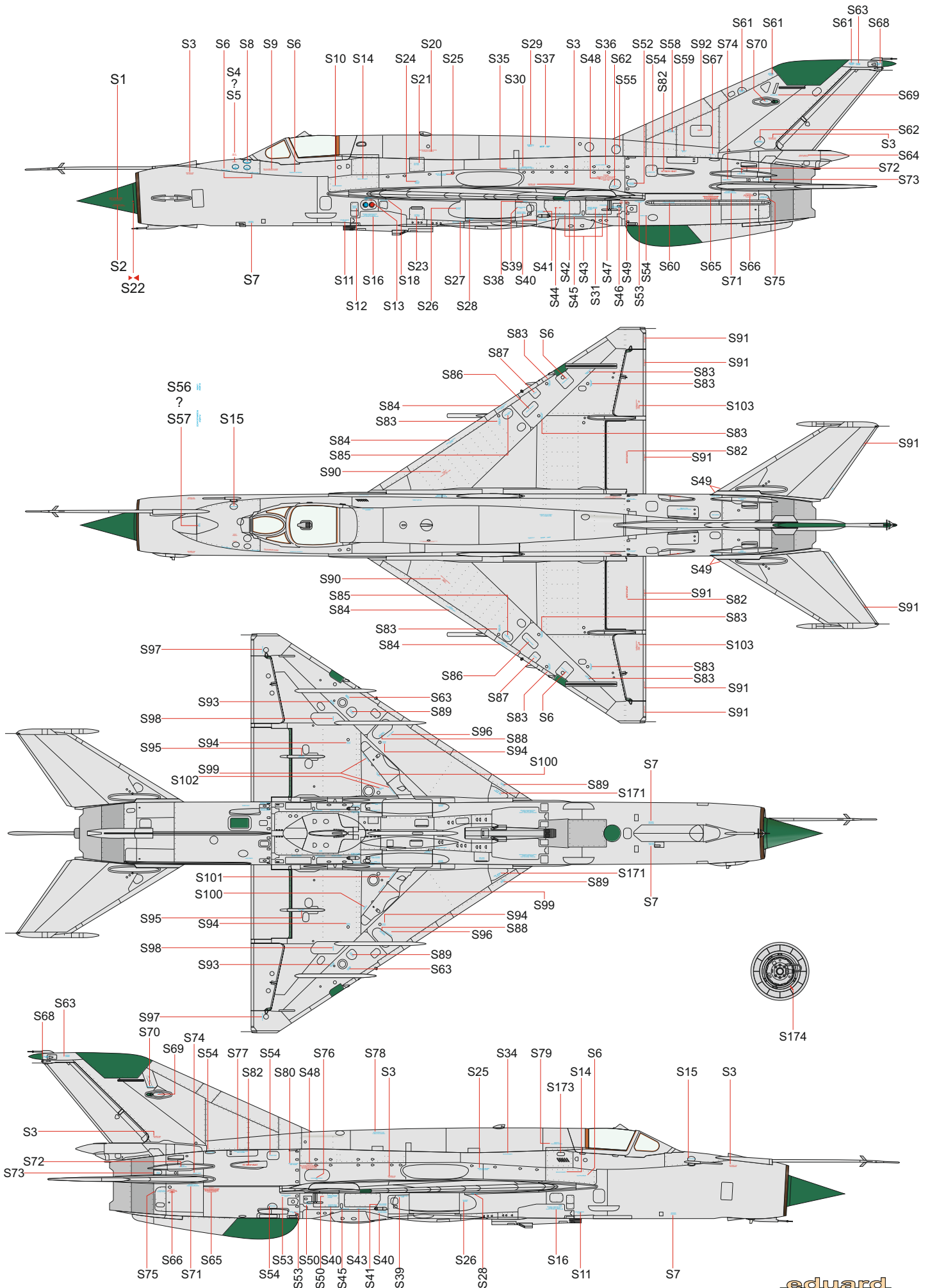

# Eduard goodies for

# MiG-21bis 1/48

- 48704 MiG-21 ladder (PE-Set)
- 48994 MiG-21 surface panels (PE-Set)
- 48999 MiG-21bis exterior (PE-Set)
- 49065 MiG-21 KM-1 seatbelts FABRIC (PE-Set)
- 49110 MiG-21 seatbelts STEEL (PE-Set)
- 491036 MiG-21bis interior (PE-Set)
- FE1149 MiG-21bis Weekend (PE-Set)
- 644033 MiG-21bis LööK (Brassin)
- 648025 Rocket launcher UB-16 and UB-32 (Brassin)
- 648026 MiG-21 wheels (Brassin)
- 648030 MiG-21 seat late (Brassin)
- 648049 MiG-21 wheel wells (Brassin)
- 648050 MiG-21BIS interior (Brassin)
- 648051 MiG-21BIS exhaust nozzle (Brassin)
- 648064 MiG-21 late airbrakes (Brassin)
- 648080 MiG-21 undercarriage legs BRONZE (Brassin)
- 648082 R-60 / AA-8 Aphid (Brassin)
- 648125 R-3S / AA-2 Atoll-A (Brassin)
- 648126 OFAB-100 Soviet bombs (Brassin)
- 648127 OFAB-250 Soviet bombs (Brassin)
- 648136 S-24 rocket (Brassin)
- 648173 UB-16 rocket launcher (2 pcs) (Brassin)
- 648424 FAB-500 M54 bombs (Brassin)
- 648445 R-13M missiles (Brassin)
- 648490 MiG-21 F.O.D (Brassin)
- 3DL48026 MiG-21bis SPACE (3D Decal set)
- EX751 MiG-21bis Weekend (Mask)



Cat. No. 644033



Cat. No. 648050

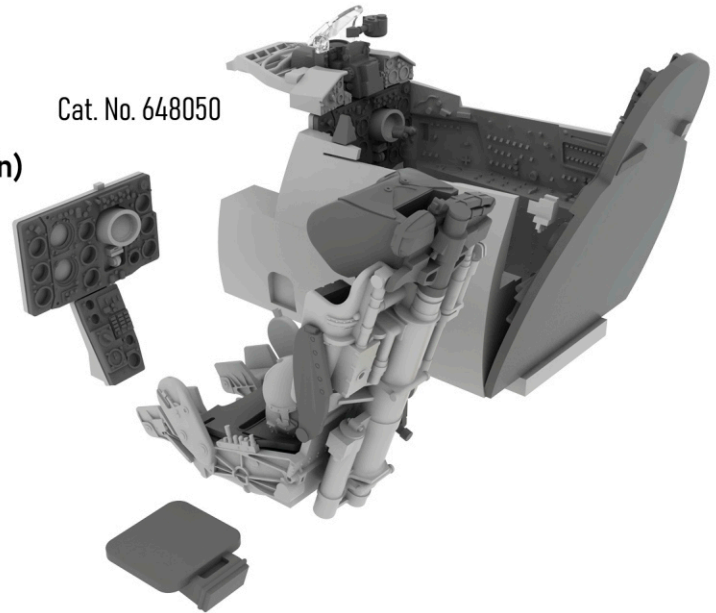

Cat. No. 648080

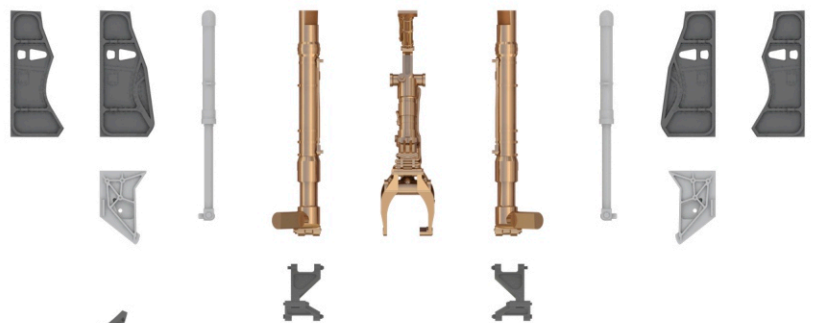

Cat. No. 648082

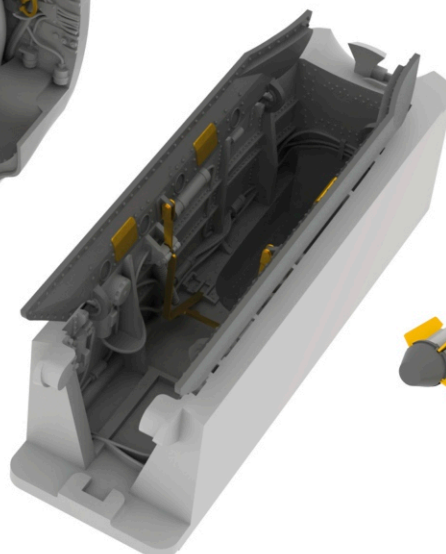
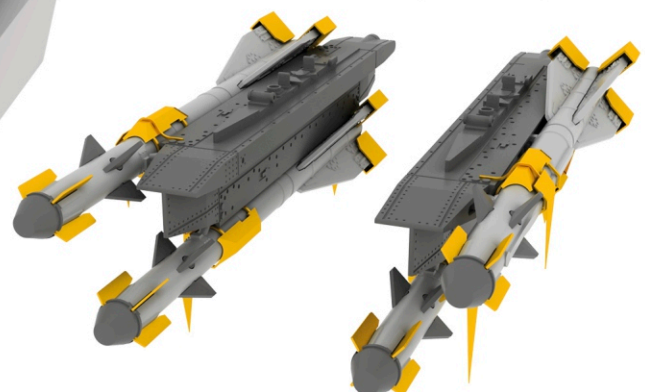

Cat. No. 648049

