

PLASTIC PARTS

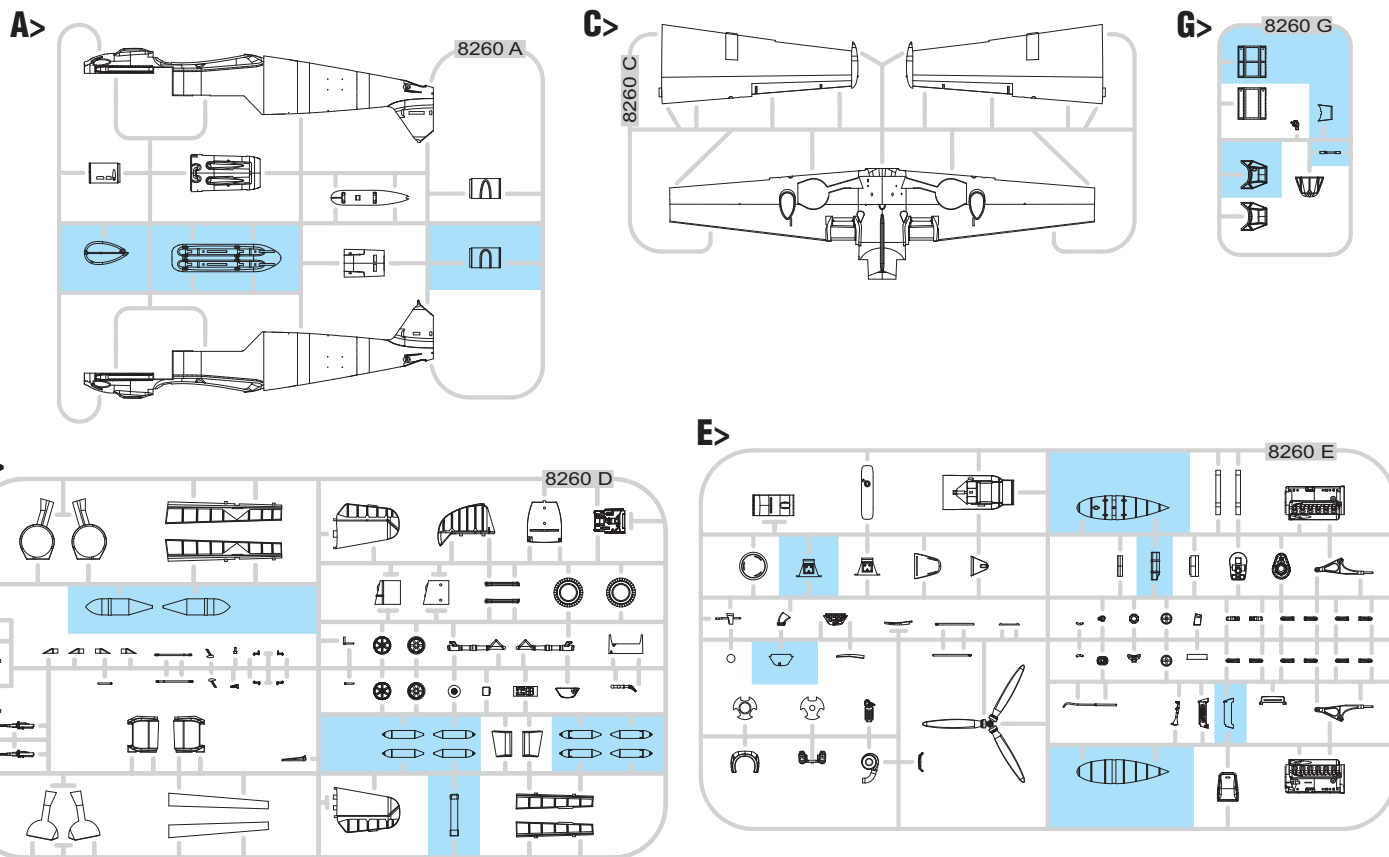

GUNZE	MISSION MODELS		
H2	C2	MMP-047	BLACK
H11	C62	MMP-001	FLAT WHITE
H12	C33	MMP-047	FLAT BLACK
H47	C41	MMP-012	RED BROWN
H64	C17	MMP-087	DARK GREEN RLM71
H65	C18	MMP-088	BLACK GREEN RLM70
H67	C115	MMP-057	LIGHT BLUE RLM65

GUNZE	MISSION MODELS		
H70	C60	MMP-056	GRAY RLM02
H77	C137	MMP-047	TIRE BLACK
H90	C47		CLEAR RED
H94	C138		CLEAR GREEN
H413	C113	MMP-090	YELLOW RLM04
H414	C114	MMP-003	RED RLM23
H416	C116	MMP-089	BLACK GRAY RLM66

METAL COLOR	METALLICS	
MC213	MMM-006	STAINLESS
MC214	MMM-001	DARK IRON
MC218	MMM-003	ALUMINIUM
METAL COLOR	METALLICS	
SM01	MMC-001	SUPER CHROME

ATTENTION * UPOZORNĚNÍ * ACHTUNG * ATTENTION

- (GB)** Carefully read instruction sheet before assembling. When you use glue or paint, do not use near open flame and use in well ventilated room. Keep out of reach of small children. Children must not be allowed to suck any part, or pull vinyl bag over the head.
- (CZ)** Před započatím stavby si pečlivě prostudujte stavební návod. Při používání barev a lepidel pracujte v dobře větrané místnosti. Lepidla ani barvy nepoužívejte v blízkosti otevřeného ohně. Model není určen malým dětem, mohlo by dojít k požití drobných dílů.
- (D)** Vor dem Zusammenbau die Bauanleitung gut durchlesen. Kleber und Farben nicht in der Nähe von offenem Feuer verwenden und für eine ausreichende Belüftung sorgen. Den Bausatz von kleinen Kindern fernhalten. Vermeiden Sie, dass Kinder Bauteile in den Mund nehmen oder sich Plastiktüten über den Kopf ziehen.
- (F)** Lire soigneusement la fiche d'instructions avant d'assembler. Ne pas utiliser de colle ou de peinture à proximité d'une flamme nue, et aérer la pièce de temps en temps. Garder hors de portée des enfants en bas âge. Ne pas laisser les enfants mettre en bouche ou sucer les pièces, ou passer un sachet vinyl sur la tête.

INSTRUCTION SIGNS * INSTR. SYMBOLY * INSTRUKTION SINNBILDEN * SYMBOLES

OPTIONAL VOLBA	BEND OHNOUT	SAND BROUSIT	OPEN HOLE VYVRTAT OTVOR	SYMETRICAL ASSEMBLY SYMETRICKÁ MONTÁŽ	REMOVE ODŘÍZNOUT	REVERSE SIDE OTOČIT	APPLY EDUARD MASK AND PAINT POUŽIT EDUARD MASK NABARVIT

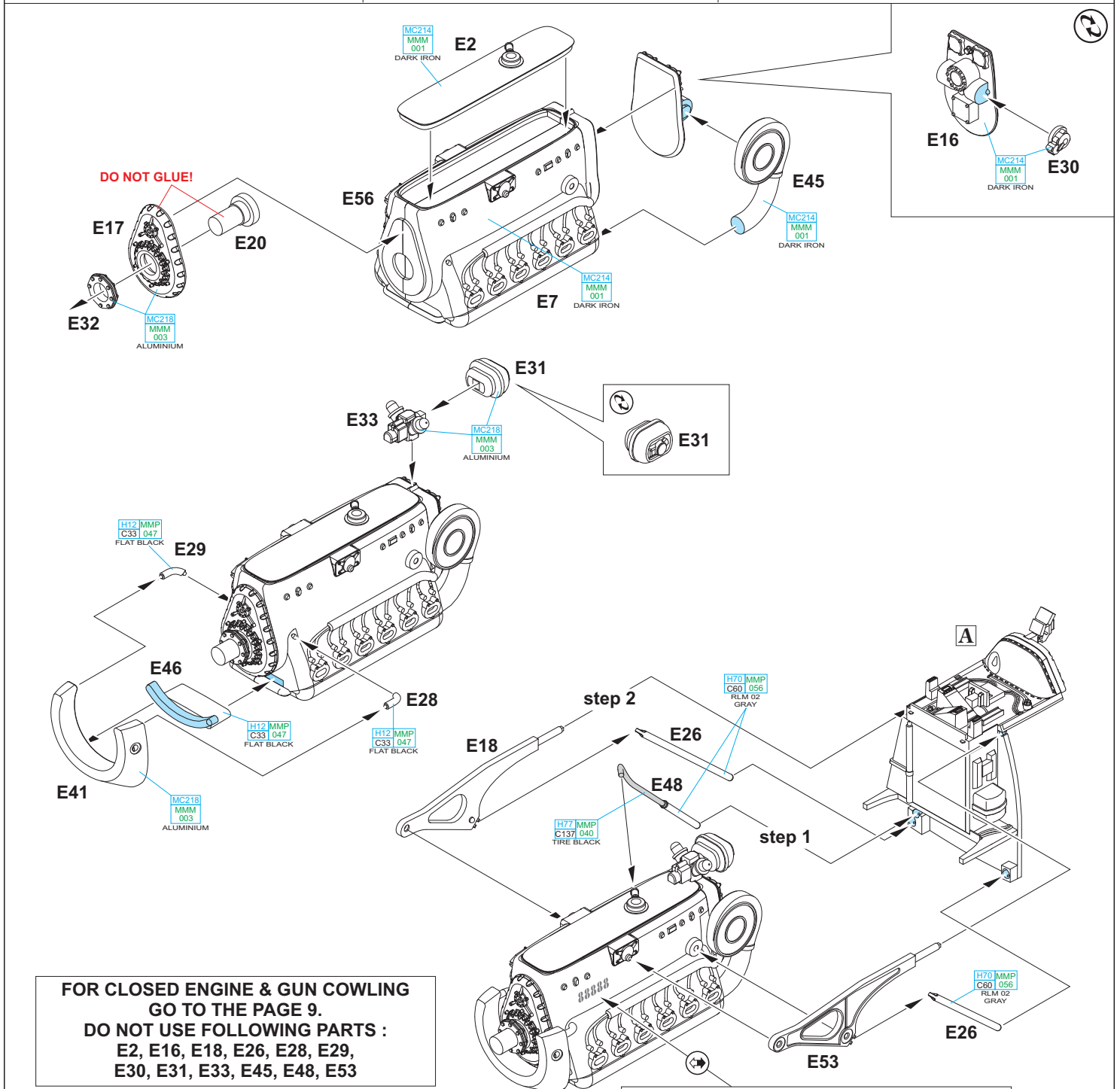
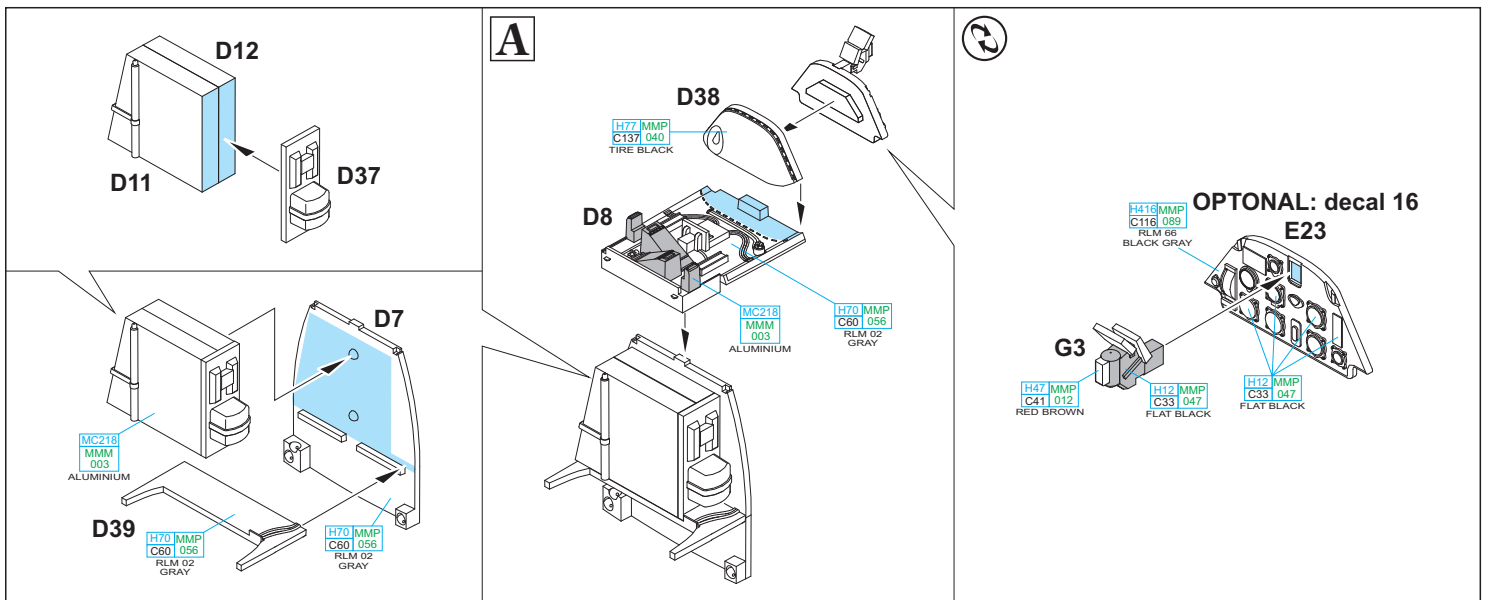

**FOR CLOSED ENGINE & GUN COWLING
GO TO THE PAGE 9.
DO NOT USE FOLLOWING PARTS :**
E2, E16, E18, E26, E28, E29,
E30, E31, E33, E45, E48, E53

**APPLY DECAL- ENGINE SERIAL NUMBER
SEE YOUR REFERENCE FOR THE EXACT NUMBER**

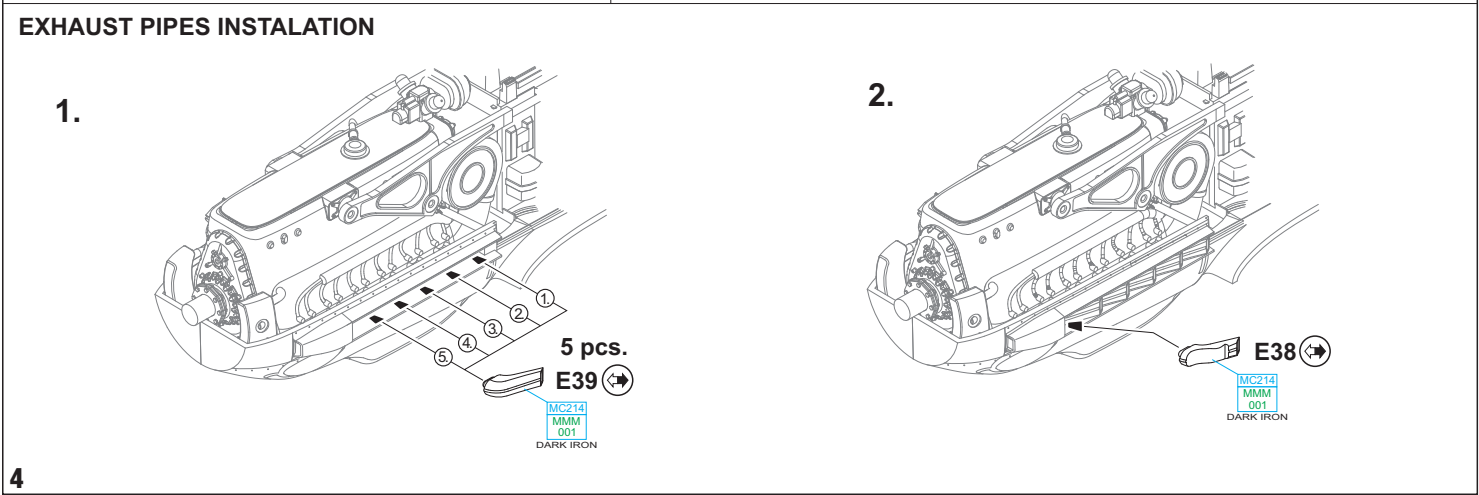
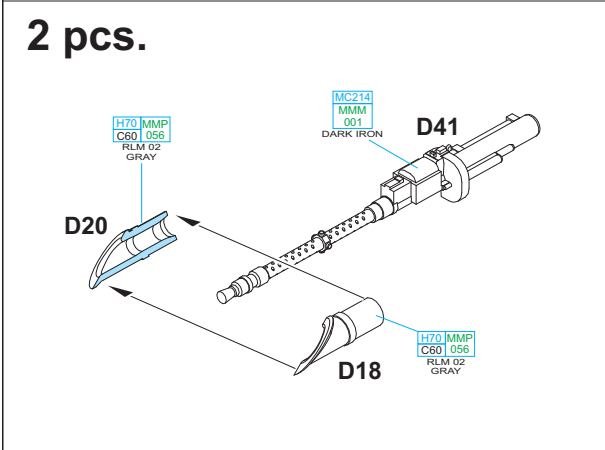
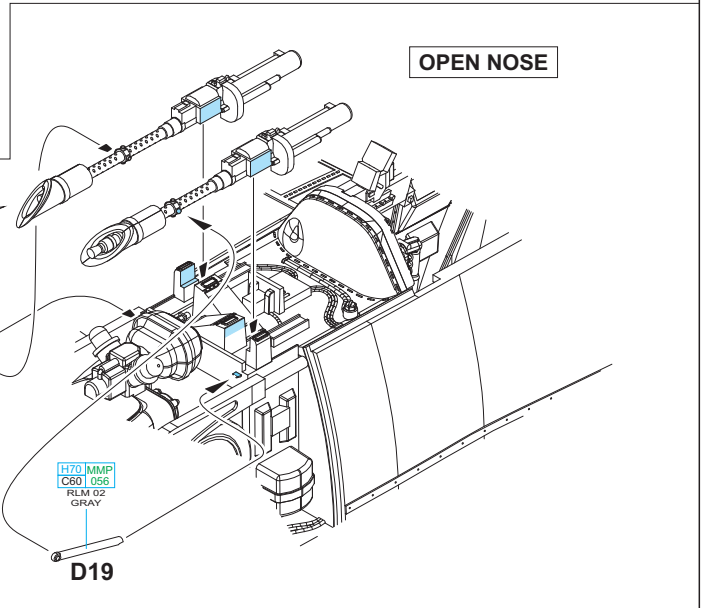
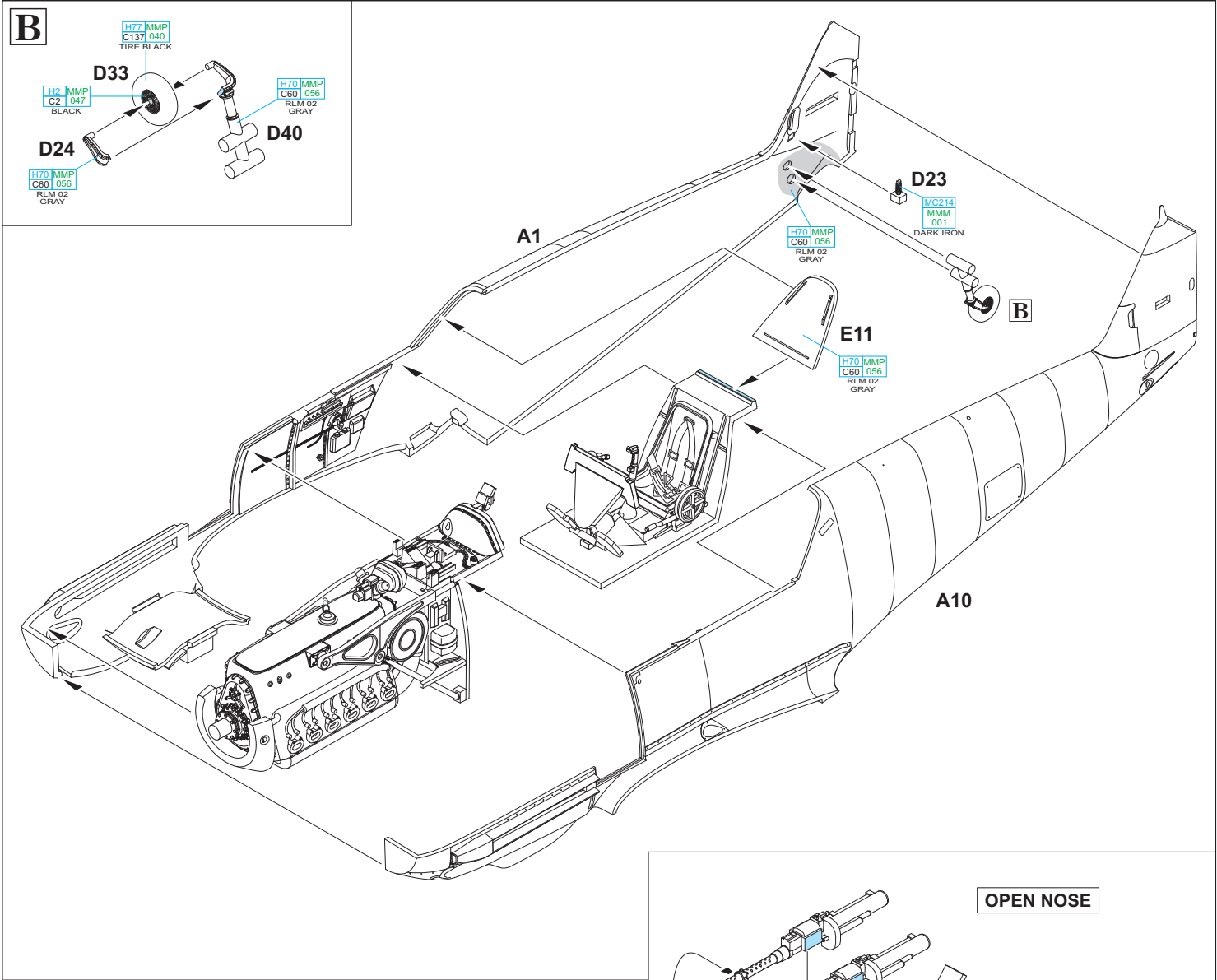

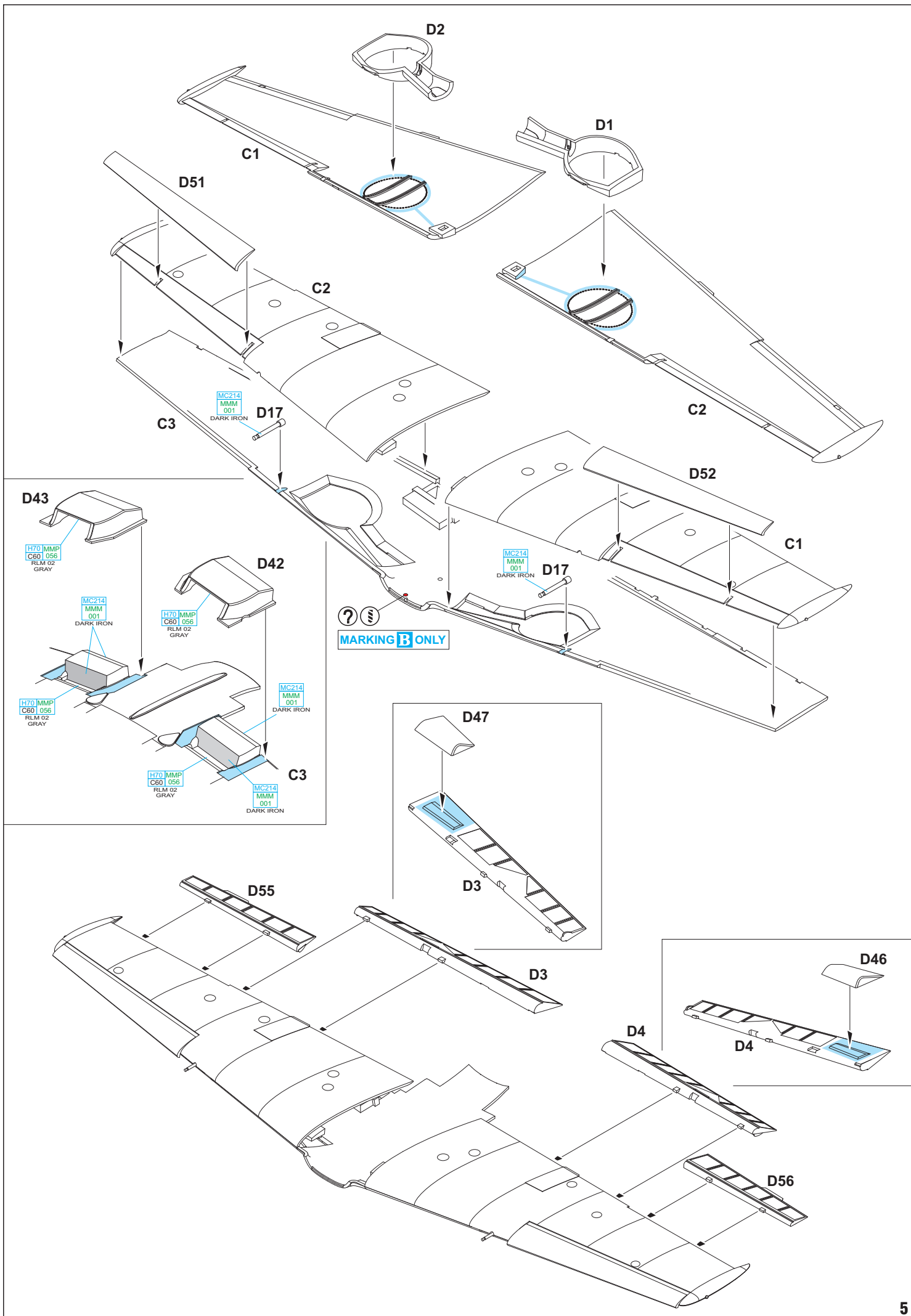

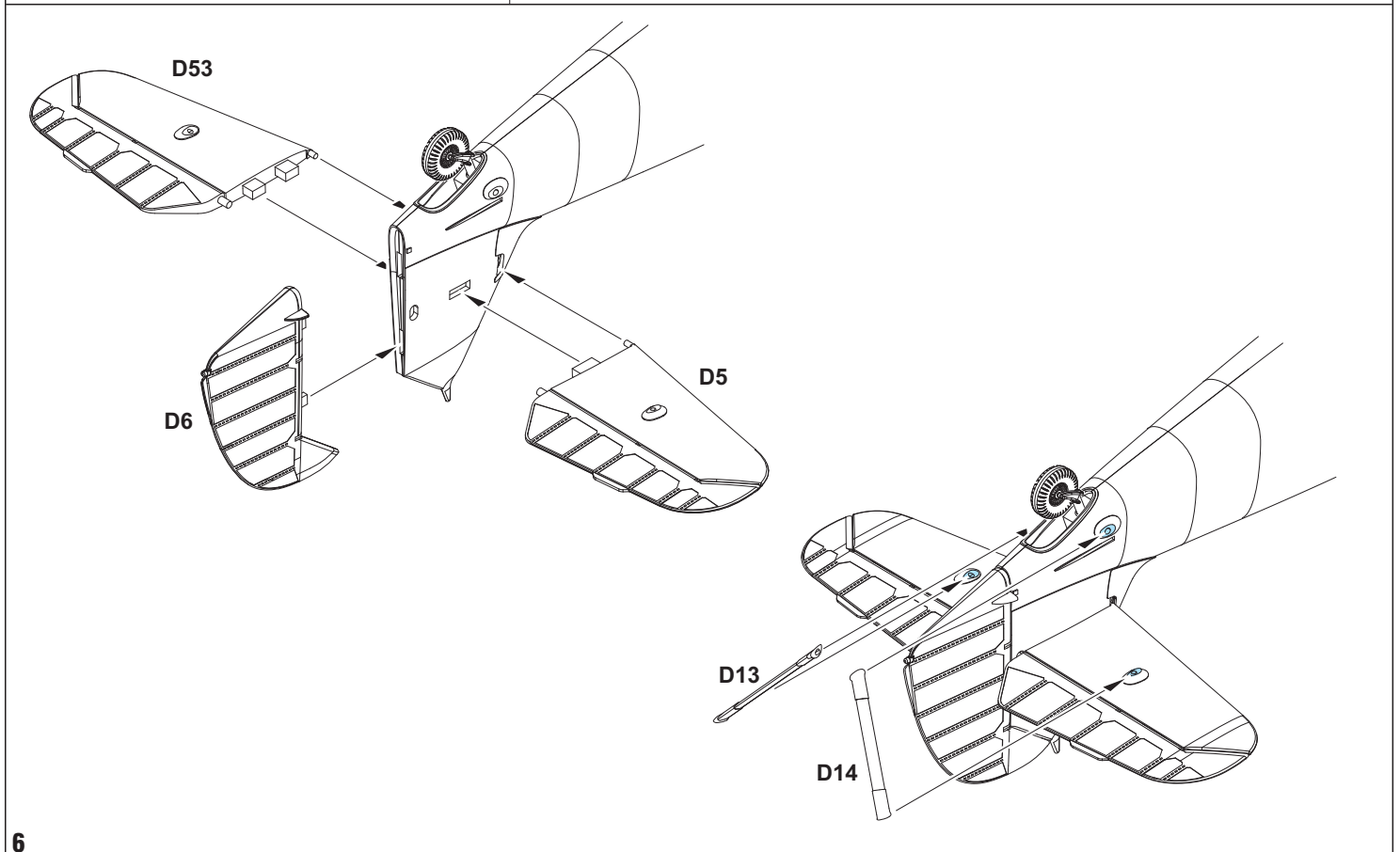
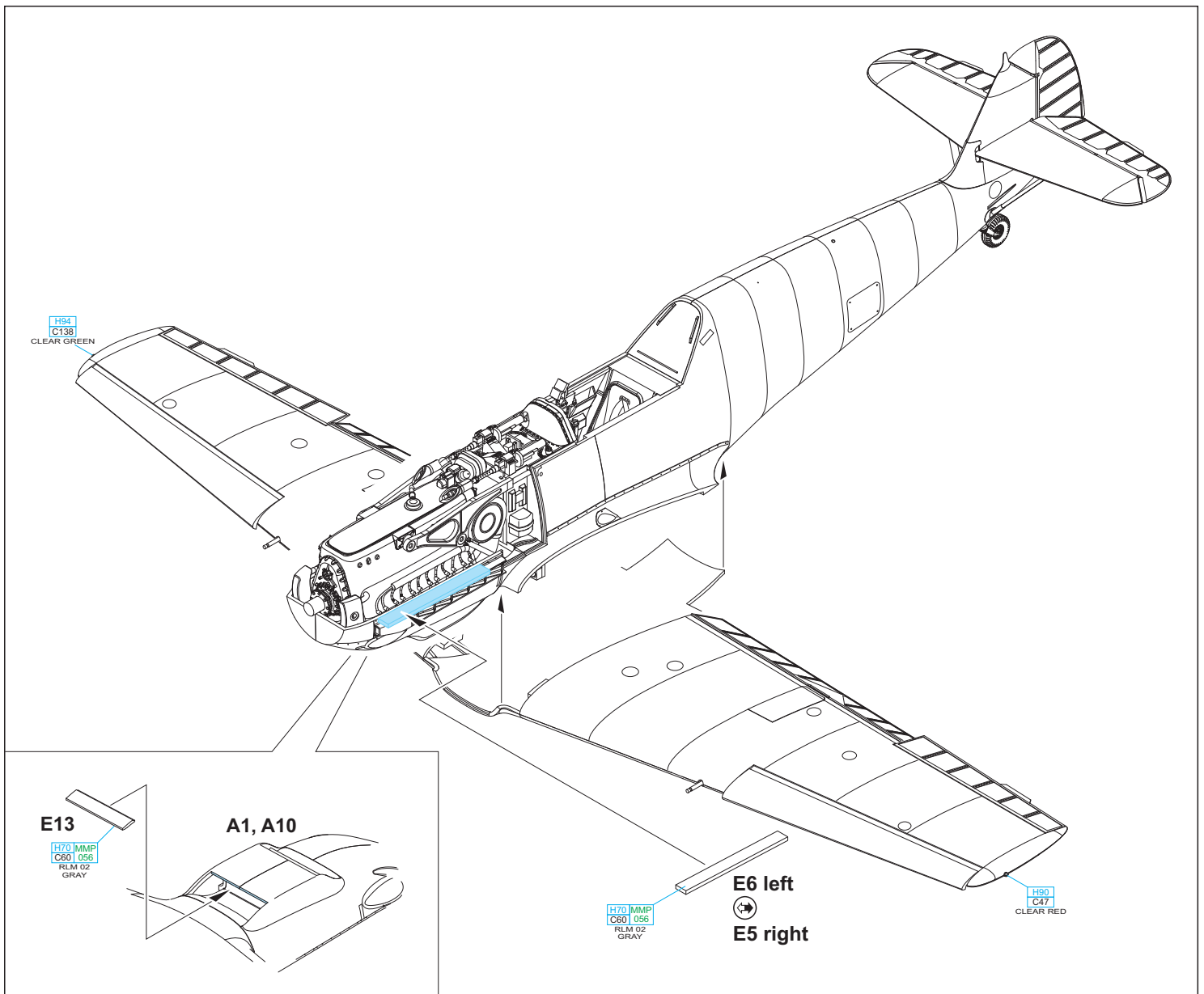

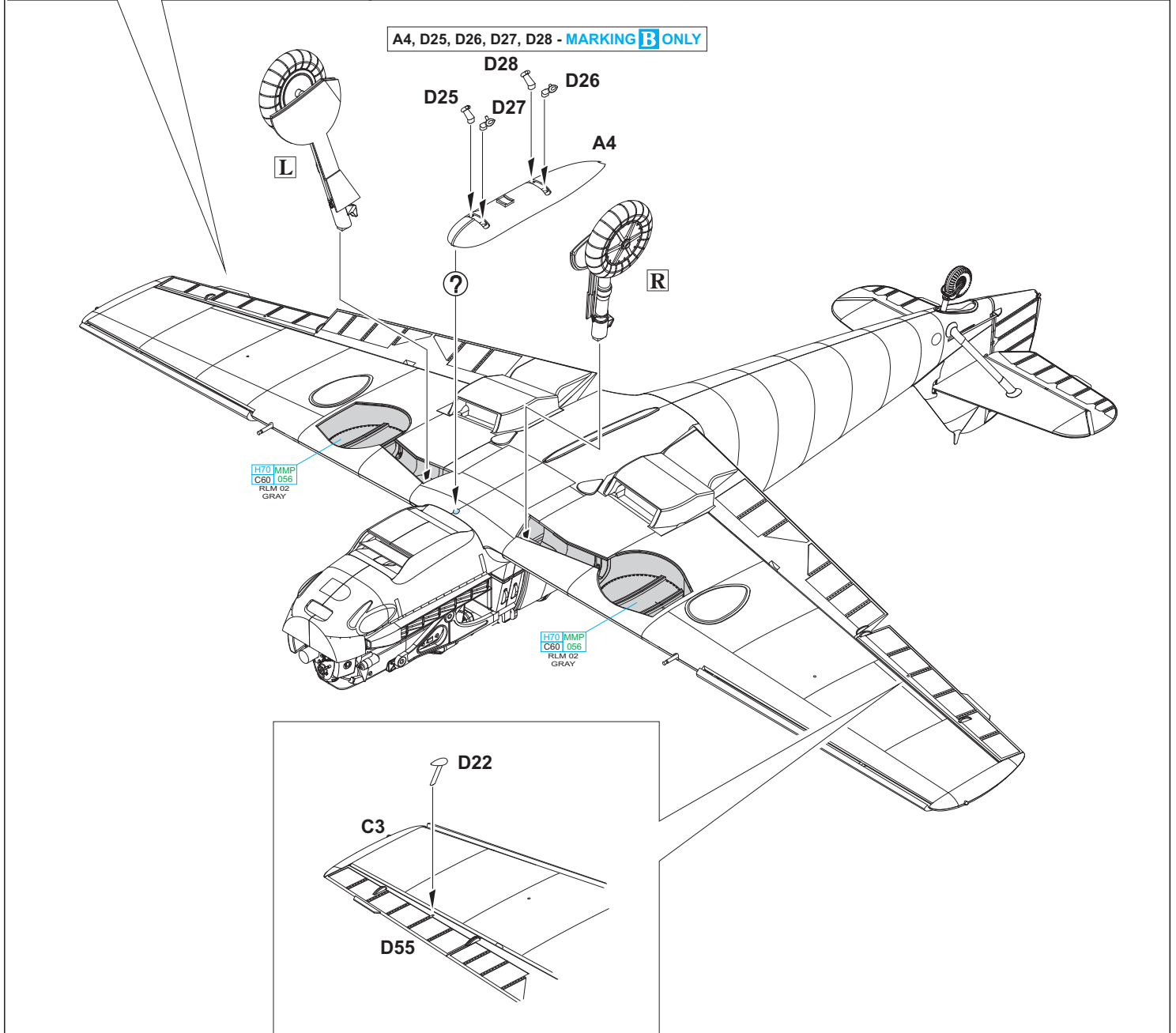
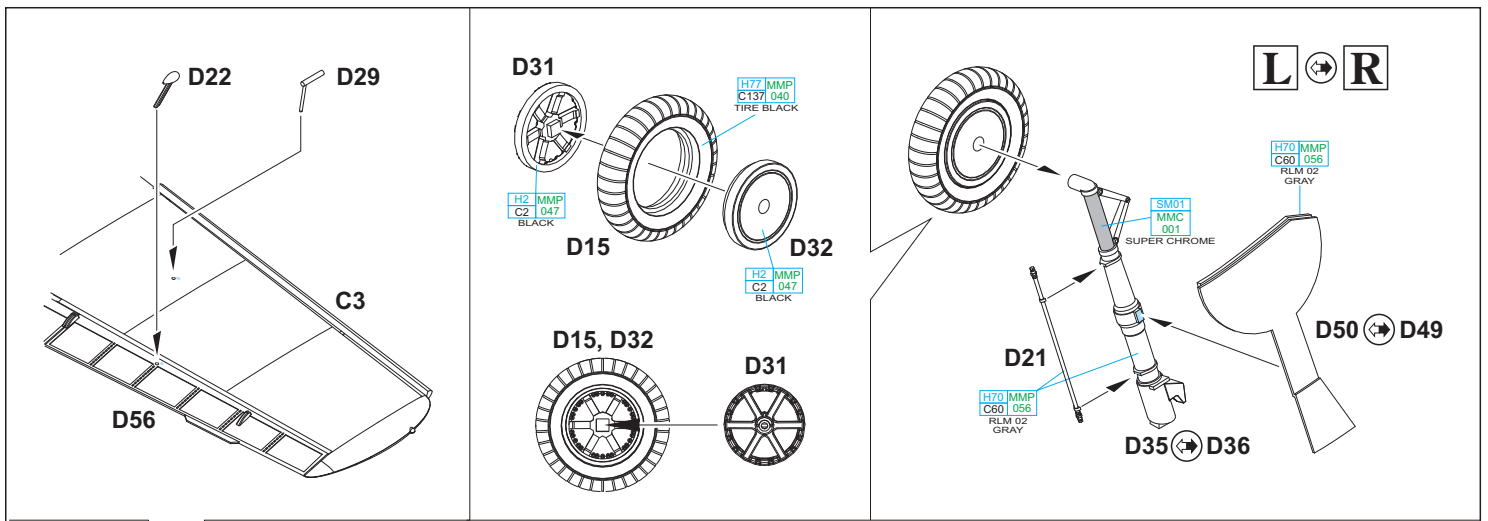

THE CORRECT POSITION OF THE UNDERCARRIAGE LEGS

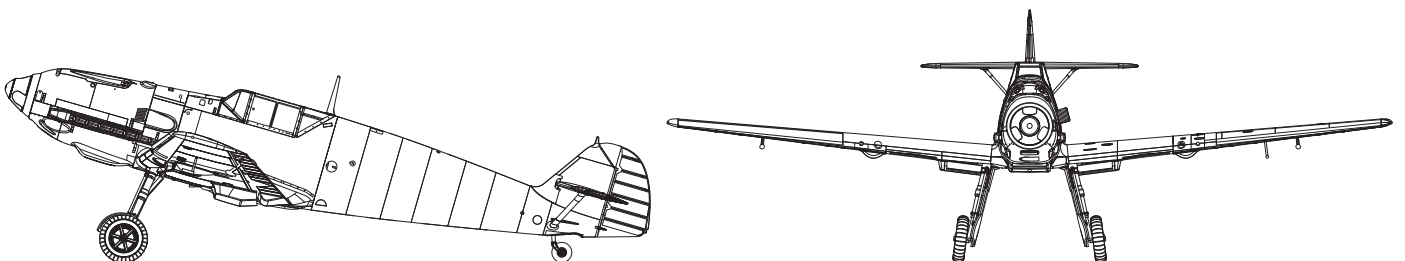

**FOR CLOSED NOSE
SEE PAGE 9**

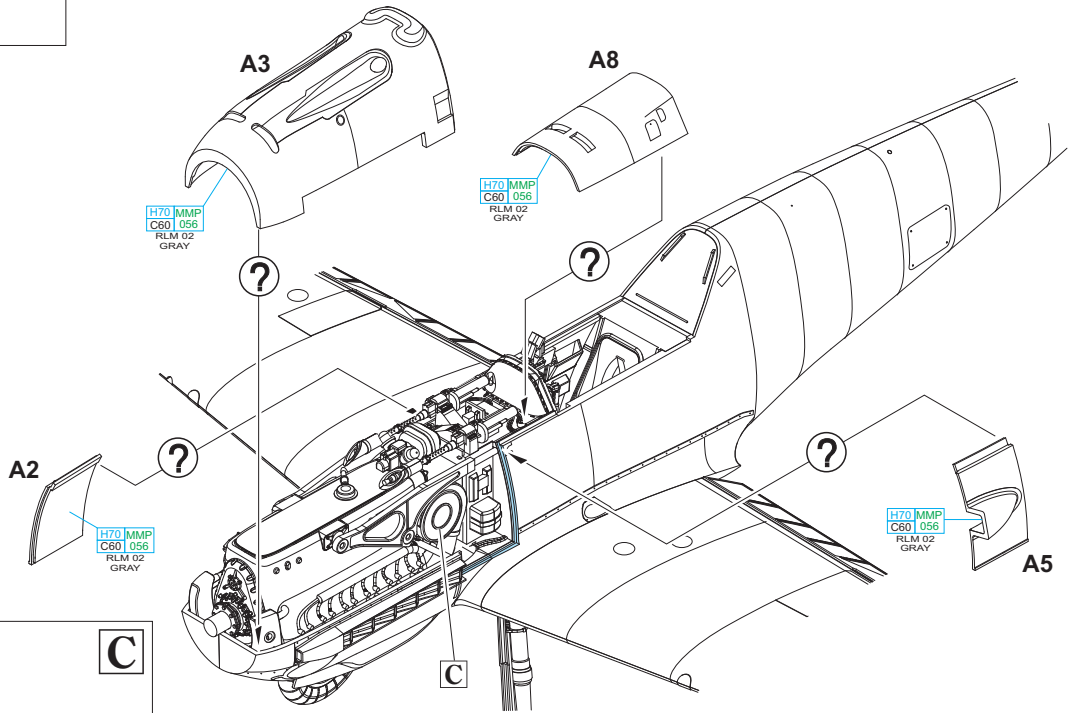

C

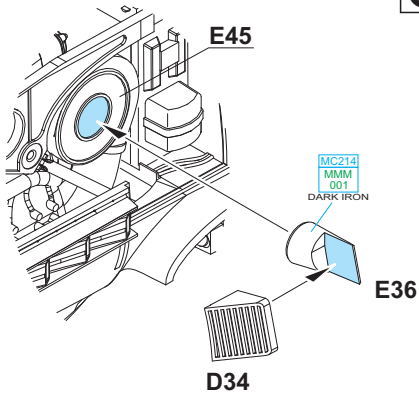

OPEN

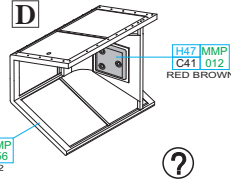

CLOSED



D

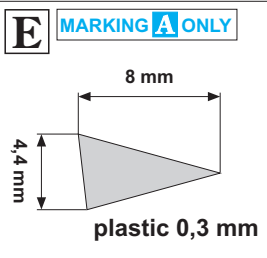
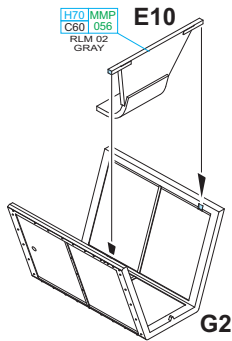

E

H413 MMP C113 090 RLM 04 YELLOW

E47

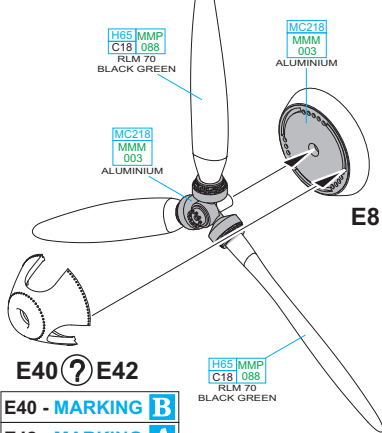

E40 - MARKING B
E42 - MARKING A

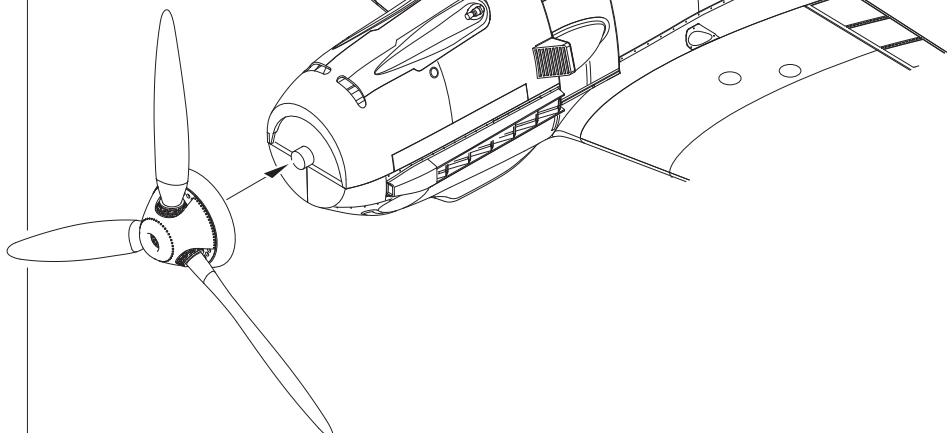

FOR CLOSED ENGINE COMPARTMENT ONLY

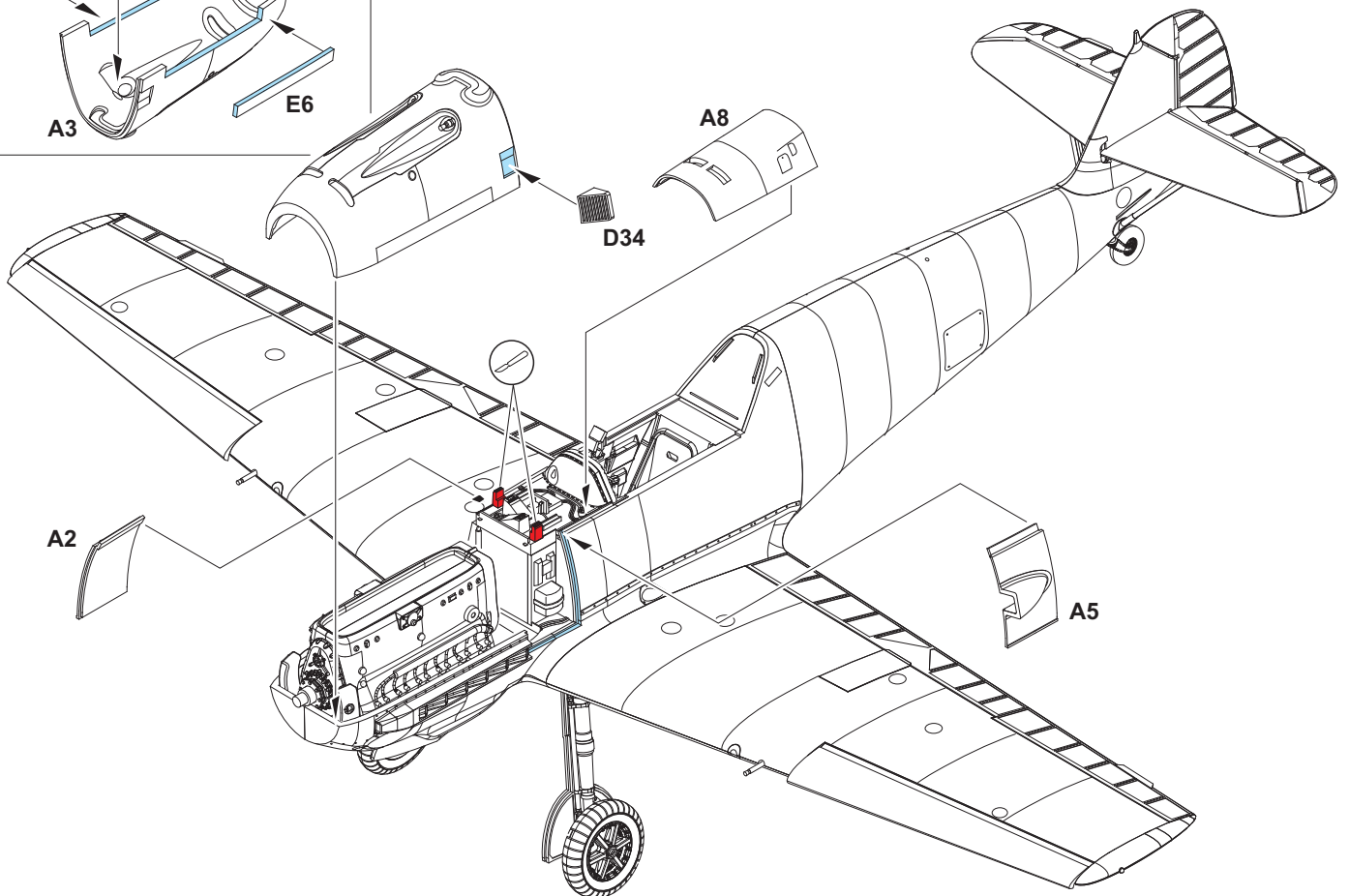
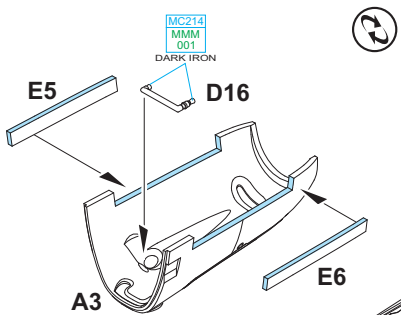
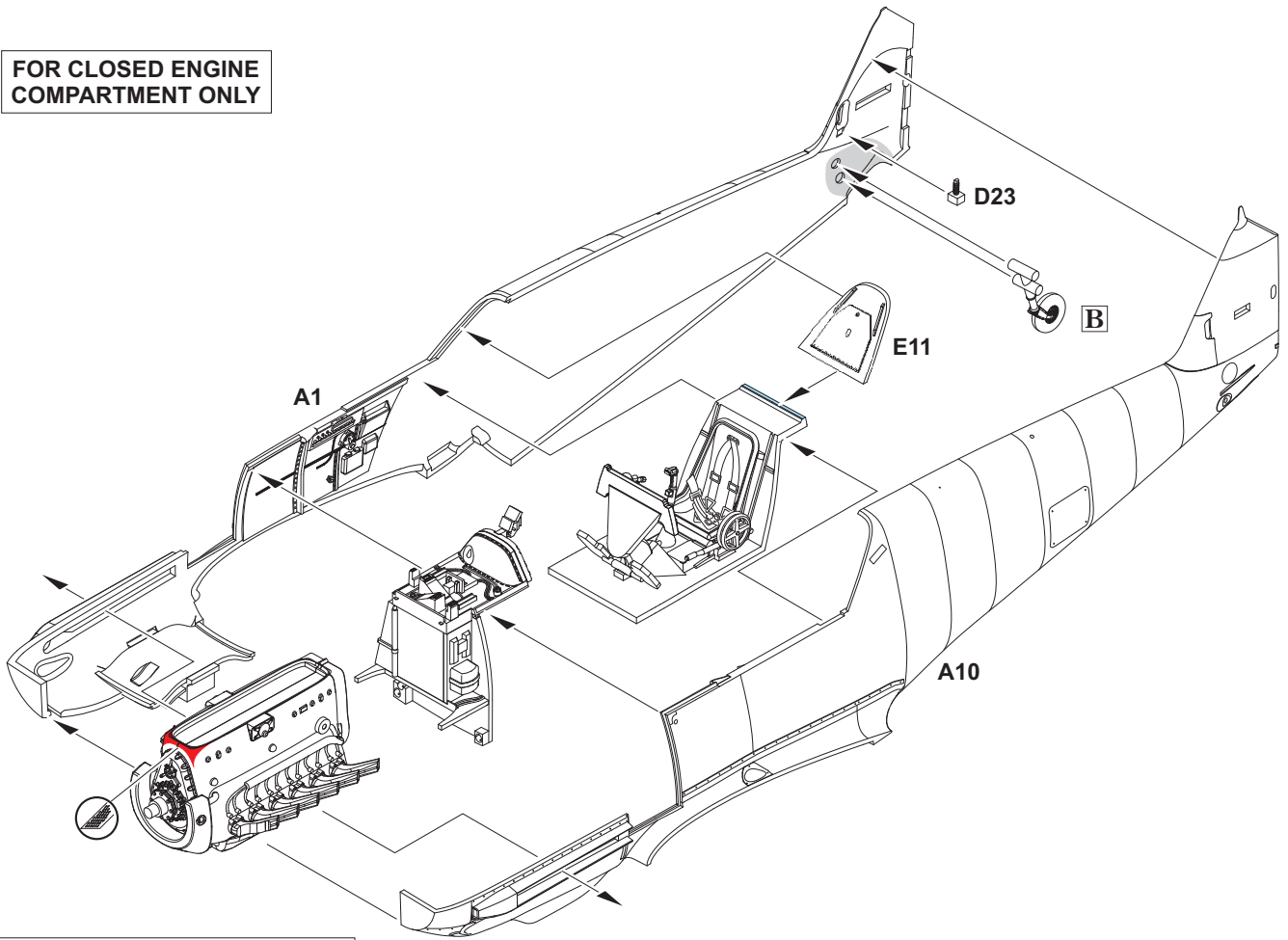

A W. Nr. 1559, flown by Hptm. Wilhelm Balthasar, CO of 7./JG 27, Carquebut, France, July 1940

The future Knight Cross with Oak Leaves recipient, Wilhelm Balthasar, was born on February 2nd, 1914 in Fulda. In 1933 he joined Reichswehr, in 1935, by his own request, he was transferred to Luftwaffe where he underwent the pilot training. During the Spanish Civil War he initially served with bomber and reconnaissance units, since September 1937 with fighter detachment of the Legion Condor. In March 1938 he returned to Germany. At the outbreak of World War II Oblt. Balthasar served as 1. Staffel JG 1 commander. This unit saw combat for the first time during the offensive against The Netherlands, Belgium and France. It was the time when Balthasar demonstrated his marksman skills, during the Western Europe campaign he shot down 23 enemy airplanes. As of June 5th, 1./JG 1 was re-designated as 7./JG 27. On September 1st, 1940 he was promoted to command III./JG 3 and in the air battles over the Southern England achieved further seventeen kills. In the meantime, on February 16th, 1941, he was promoted to command JG 2. His luck ran out during the combat with the RAF fighters over Aire on July 3rd, 1941. During the dive his Bf 109F-4 wing broke off and Balthasar perished at the impact with the ground. Balthasar's aircraft, camouflaged in RLM 71/02/65 colors, carried the non-standard marking on the engine cowling. There is a unit marking painted under the windshield, kill markings are painted on the vertical tail surface and rudder.

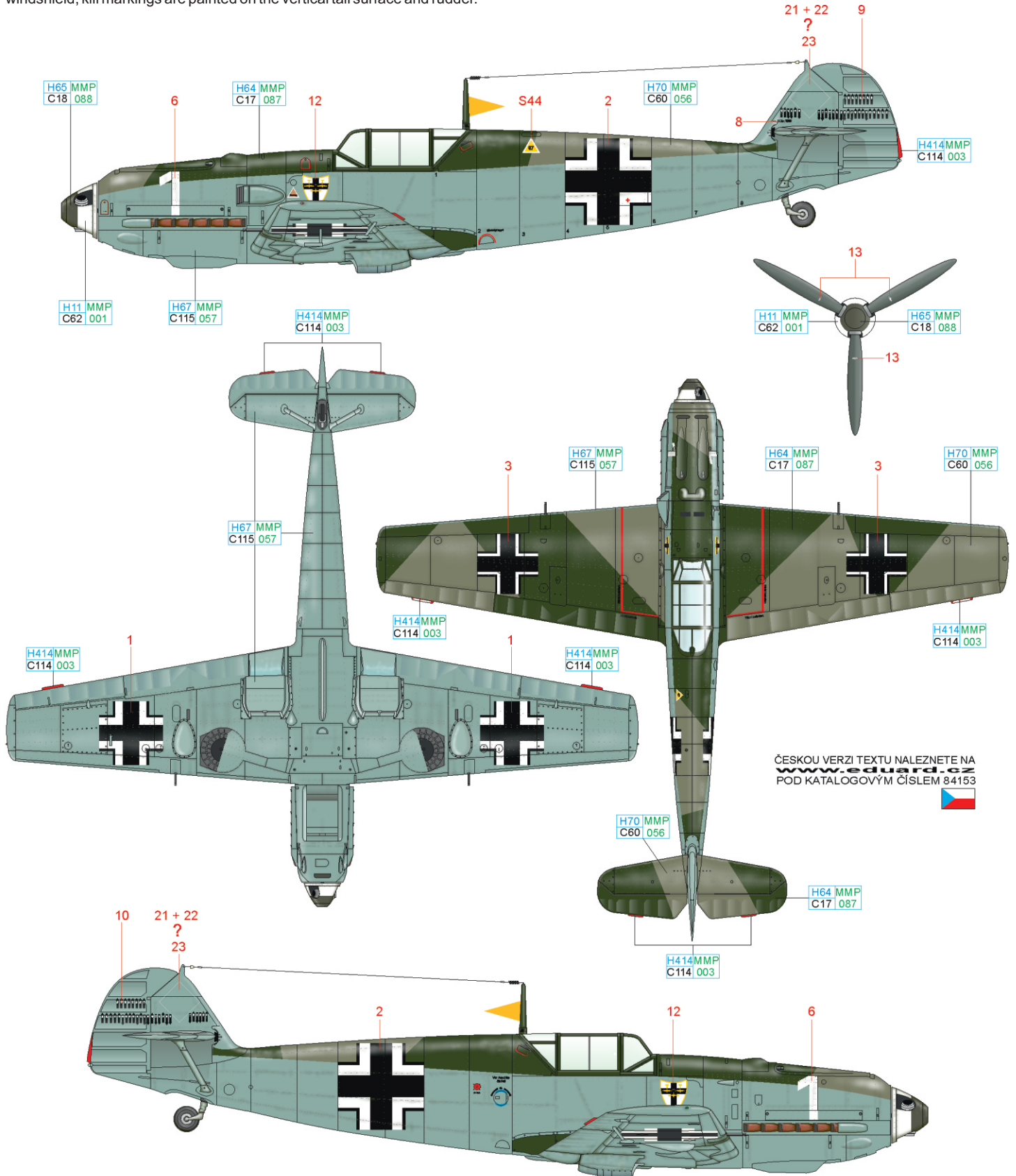

ČESKOU VERZI TEXTU NALEZNETE NA www.eduard.cz POD KATALOGOVÝM ČÍSLEM 84153



RLM 02	H70 MMP C60 056	RLM 71	H64 MMP C17 087	RLM 65	H67 MMP C115 057	WHITE	H11 MMP C62 001	RLM 70	H65 MMP C18 088	RLM 23	H414MMP C114 003
--------	-----------------	--------	-----------------	--------	------------------	-------	-----------------	--------	-----------------	--------	------------------

eduard

B W. Nr. 5901, flown by Oblt. Walter Fiel, CO of 8./JG 53, Le Touquet-Etaples, France, September 1940

After the Luftwaffe tactics changed during the Battle of Britain, when the bombing of London and Southern England was switched to night operation, the decision was made to use certain Staffeln in the fighter-bomber roles and to lure RAF fighters into combat. One of these units was 8. Staffel JG 53 commanded by Oblt. Fiel. On October 2nd, during his unit's attack, he was jumped by superior number of Spitfires and his aircraft was damaged and made to force-land nearby the little town of East Peckham in the Kent county. The pilot was taken a prisoner of war. The camouflage in RLM 71/02/65 colors was supplemented by the gaudy marking in the form of yellow engine cowling and rudder. The original aircraft's marking was probably over-sprayed with RLM 70 color, the unit marking, originally located on the engine cowling, was over-painted in the red stripe wrapping around the whole engine cowling.

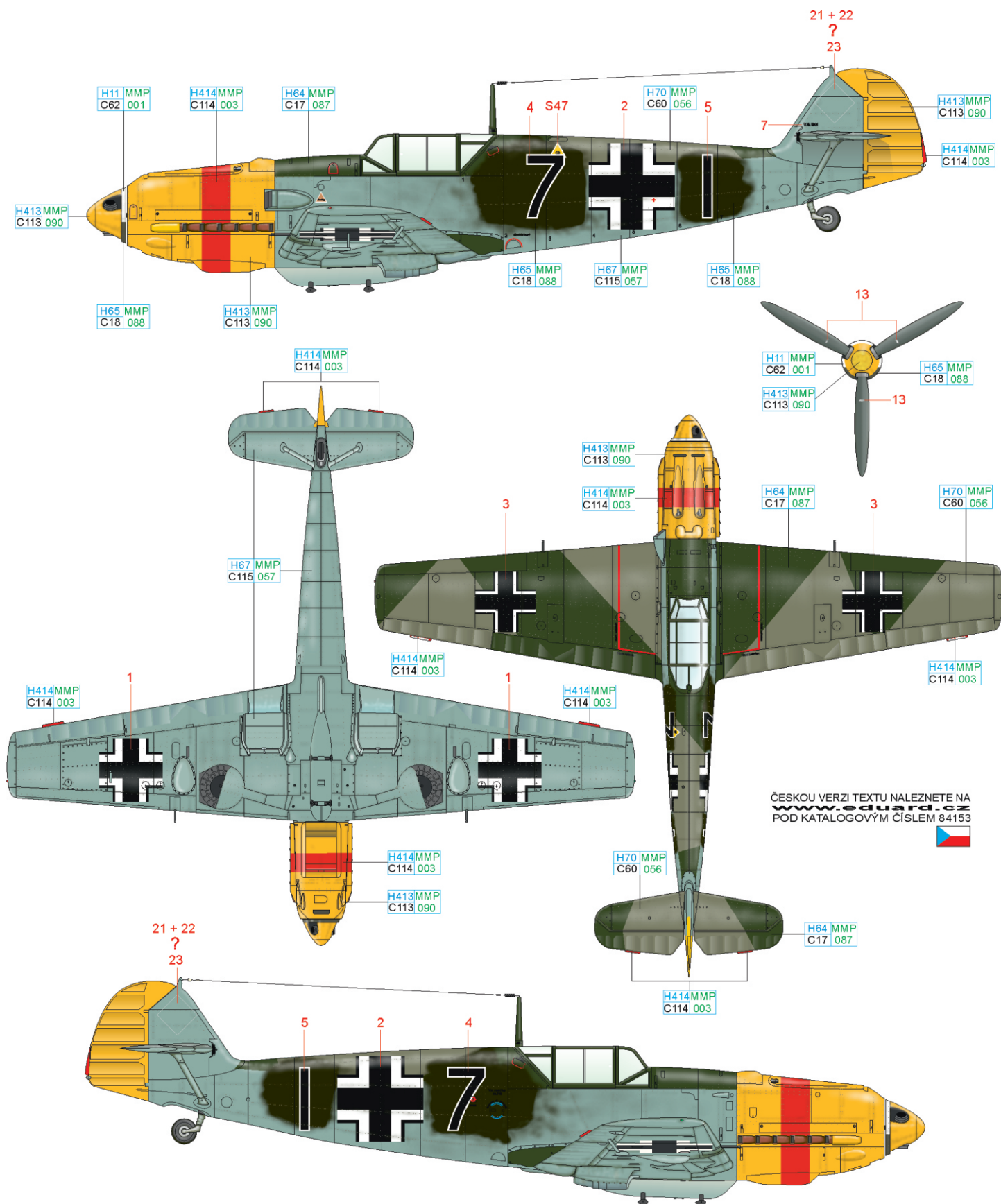

ČESKOU VERZI TEXTU NALEZNETE NA www.eduard.cz POD KATALOGOVÝM ČÍSLEM 84153



RLM 02	H70 MMP C60 056	RLM 71	H64 MMP C17 087	RLM 65	H67 MMP C115 057	WHITE	H11 MMP C62 001	RLM 70	H65 MMP C18 088	RLM 23	H414MMP C114 003	RLM 04	H413MMP C113 090
--------	-----------------	--------	-----------------	--------	------------------	-------	-----------------	--------	-----------------	--------	------------------	--------	------------------

eduard

