

# Spitfire Mk.Vc

eduard

1/48 Scale Plastic Model Kit

**WEEKEND**  
edition



item # 84192

The Supermarine Spitfire is so iconic, that virtually everyone can recognize it. The service of this elegant fighter spanned remarkable 13 years. It entered the service at the end of biplane era and stayed on frontline duty until the dawn of jet age.

By the early 30s the RAF was looking for replacement of its ageing Hawker Fury biplane fighters. The need of considerably faster aircraft was obvious, as the racing monoplane floatplanes of that time were reaching about twice the speed of the Fury.

One of the most successful designers of the racing floatplanes was Reginald J. Mitchell. His Supermarine S.6B raised the world speed record to 407 mph (655 km/h) on September 20, 1931, and British Air Ministry, under influence of such achievement, issued the specification F.7/30 in October 1931. Although it called for modern pursuit aircraft capable of at least 250 mph (400 km/h), seven out of eight entries were biplane designs. The only monoplane proposal was Mitchell's Supermarine 224, but the aircraft with a gull wing, fixed undercarriage and Rolls-Royce Goshawk engine was a disappointment as it lacked speed and rate of climb. Due to that, the Gloster Gladiator biplane was declared a winner.

## Early work

The fiasco with Type 224 did not prevent Mitchell from further work. He persuaded the Supermarine company to fund the private work on the completely new design Type 300 using the brand new engine, the Rolls-Royce PV12, later known as the Merlin. The Air Ministry noticed the initiative and expressed interest, followed by the specification F.37/34 issued on December 28, 1934, which allowed to fund a prototype armed with four wing-mounted guns. By early April 1935 Mitchell received the details of specification F.10/35, which was calling for eight guns. The change was made on cost of bomb provision removal and reduction of the fuel tanks volume to sixty-six gallons. The decision caused the so called "short legs" of the Spitfire, meaning a lack of range.

The Supermarine Type 300 made its maiden flight on March 5, 1936, an initial contract to produce 310 Spitfires, as the new type was named, was signed in June 1936 and the first unit to receive the new fighter was No. 19 Squadron at Duxford in August 1938.

## Searching for performance

The Spitfire's development was an ongoing process from very early stage of its service and incorporated many changes. From the early Mk.I and Mk.II the development reached the point, where a more substantial performance step was required.

After trials with the Merlin XX engine, installed in the prototype of the Spitfire Mk.III, Rolls-Royce offered a viable and quick solution in late 1940, the concurrently developed and simpler to manufacture Merlin RM55 engine (later designated Merlin 45). It featured one-stage single-speed compressor optimized for high altitudes. Its output at 17,700 ft (5,400 m) was 1,210 hp (902 kW). The Merlin 45 was the same size as the Merlin III powering the Mk.I Spitfires, and its design allowed the Merlin III to be upgraded to the Merlin 45 by changing the supercharger. This facilitated the simple installation into the

freshly built Spitfire Mk.I and Mk.II airframes and the conversion of the existing aircraft as well.

First two converted Spitfires were test-flown at Boscombe Down, where a maximum speed of 593 kph at 20,000 ft (6,100 m) was recorded during the flight tests. The trials also brought out the problems with the De Havilland constant-speed propeller as oil of its control system was freezing at high altitudes. There were troubles with Mk.II oil cooler as well as it was not efficient enough for the more powerful engine. Even though this was considered an interim solution, as the Spitfire Mk.III production was still being planned, the order for new Spitfires was placed, or, better said, the program for converting Spitfires Mk.I and Mk.II into Spitfires Mk.V was ordered.

The CBAF (Castle Bromwich Aircraft Factory) launched the Spitfire Mk.V production in June 1941 while it was fulfilling the contract for 1,000 Mk.IIs, signed on April 12, 1939. Gradually the company received another eight orders to produce Spitfires Mk.V, of which the last one, from May 1942, largely transitioned to the manufacture of modernized Spitfires Mk.IX. Until the end of April 1943, the total production at CBAF reached 3,003 Spitfires Mk.Vb and 1,474 Spitfires Mk.Vc.

Since the summer 1943, the Spitfire Mk.V production was under way at Westland company located in Yeovil in county of Somerset. Westland manufactured various versions of Spitfire Mk.V until November 1943 and ultimately delivered a total of 140 Mk.Vb and 495 Mk.Vc. Finally, 6,464 Spitfires Mk.V of all variants were manufactured.

## This kit: Spitfire Mk.Vc

In the middle of March 1941, Spitfire X4922 built in Eastleigh at Spitfire Mk.I assembly line, arrived at Boscombe Down. It already featured Merlin 45 and was test-flown on February 7. During the trials it was fully armed and equipped and reached the maximum speed of 374,7 mph (603 kph). In Eastleigh, in the second half of February, a total of 23 Spitfire Mk.I airframes, mostly version Mk.Ib, received Merlin 45, thus becoming the first Spitfires Mk.Vb armed with four .303 machine guns and two 20mm cannons. This mark was the most produced, while there were only 94 of eight wing .303 machine guns Spitfires Mk.Ia produced. The Mk.Vc got reinforced wing which was capable of accommodating four 20mm cannons, but most of these aircraft had the same armament as the Mk.Vb.

During the two and half years of Spitfire Mk.V production, the airframe was gradually developed. Already at the beginning of the production thicker armor in comparison to Mk.I and Mk.II was introduced. Apart of the early Mk.Vbs, which were equipped with smaller U-shaped oil cooler from Mk.I, the Mk.Vc was produced with the bigger circle-shaped one to avoid the risk of engine overheating due to the insufficient cooling. The circular intake oil cooler was than retroactively installed on the first batch of Spitfires Mk.V, which were converted from Mk.Is and Mk.IIs, and became one of the main features distinguishing Spitfires Mk.V.

ATTENTION



UPOZORNĚNÍ



ACHTUNG



ATTENTION



注意



Carefully read instruction sheet before assembling. When you use glue or paint, do not use near open flame and use in well ventilated room. Keep out of reach of small children. Children must not be allowed to suck any part, or pull vinyl bag over the head.



Před započítím stavby si pečlivě prostudujte stavební návod. Při používání barev a lepidel pracujte v dobře větrané místnosti. Lepidla ani barvy nepoužívejte v blízkosti otevřeného ohně. Model není určen malým dětem, mohlo by dojít k požití drobných dílů.

INSTRUCTION SIGNS \* INSTR. SYMBOLS \* INSTRUKTION SINNBILDEN \* SYMBOLES \* 記号の説明

OPTIONAL  
VOLBABEND  
OHNOUTSAND  
BROUSITOPEN HOLE  
VYVRTAT OTVORSYMETRICAL ASSEMBLY  
SYMETRICKÁ MONTÁŽREMOVE  
ODŘÍZNOUTREVERSE SIDE  
OTOČITAPPLY EDUARD MASK  
AND PAINT  
POUŽÍT EDUARD MASK  
NABARVITPLEASE CHECK THE LATEST VERSION OF THE INSTRUCTIONS ON [www.eduard.com](http://www.eduard.com)

PARTS



DÍLY



TEILE



PIÈCES



部品

## PLASTIC PARTS

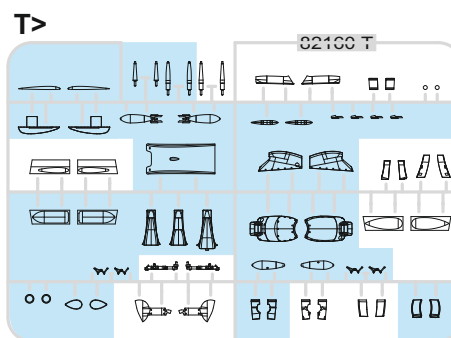
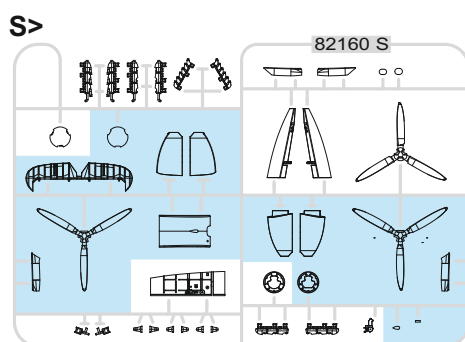
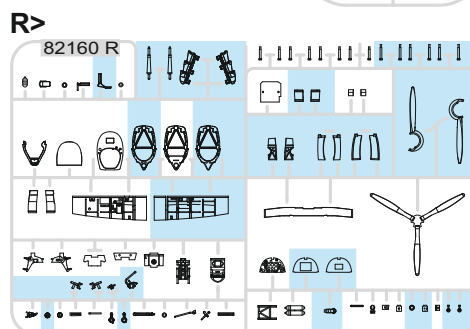
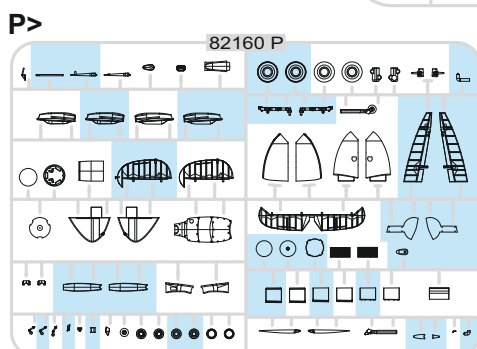
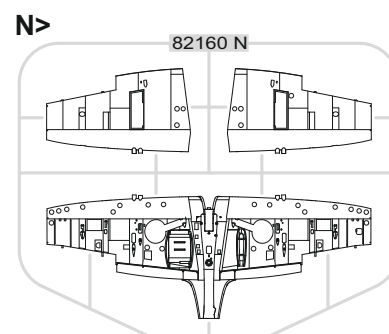
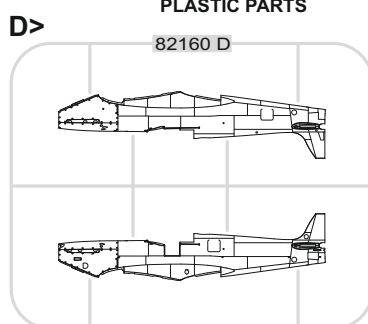
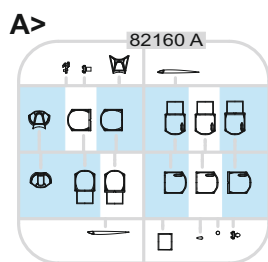

-Parts not for use. -Teile werden nicht verwendet. -Pièces à ne pas utiliser. -Tyto díly nepoužívejte při stavbě. - 使用しない部品

COLOURS



BARVY



FARBEN



PEINTURE



色

GSi Creos (GUNZE)		
AQUEOUS	Mr.COLOR	
H4	C4	YELLOW
H8	C8	SILVER
H11	C62	FLAT WHITE
H12	C33	FLAT BLACK
H13	C3	FLAT RED
H33	C81	RUSSET
H51	C11	LIGHT GULL GRAY
H52	C12	OLIVE DRAB
H71	C21	MIDDLE STONE
H72	C369	DARK EARTH
H74	C368	SKY
H77	C137	TIRE BLACK
H84	C42	MAHOGANY

GSi Creos (GUNZE)		
AQUEOUS	Mr.COLOR	
H90	C47	CLEAR RED
H94	C138	CLEAR GREEN
H330	C361	DARK GREEN
H335	C363	MEDIUM SEAGRAY
	C362	OCEAN GRAY
	C364	AIRCRAFT GRAY-GREEN
	C370	AZURE BLUE
Mr.METAL COLOR		
	MC214	DARK IRON
	MC218	ALUMINIUM
Mr.COLOR SUPER METALLIC		
	SM201	SUPER FINE SILVER

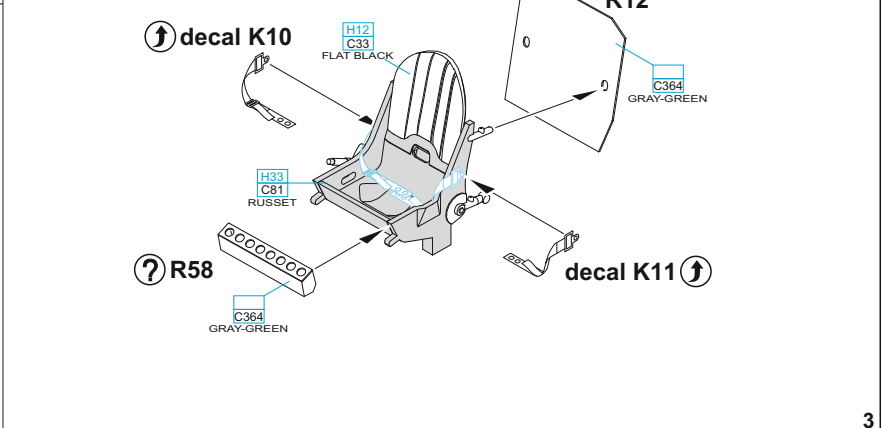
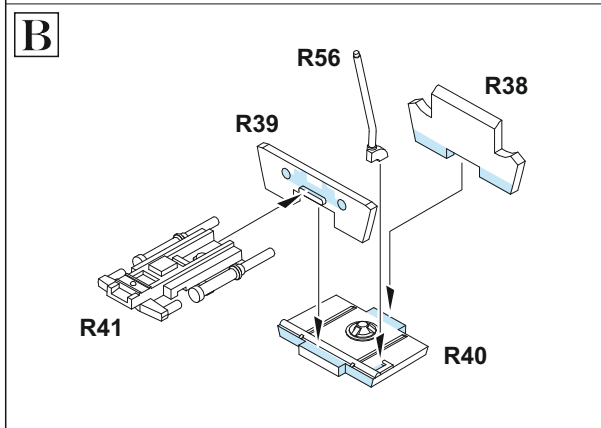
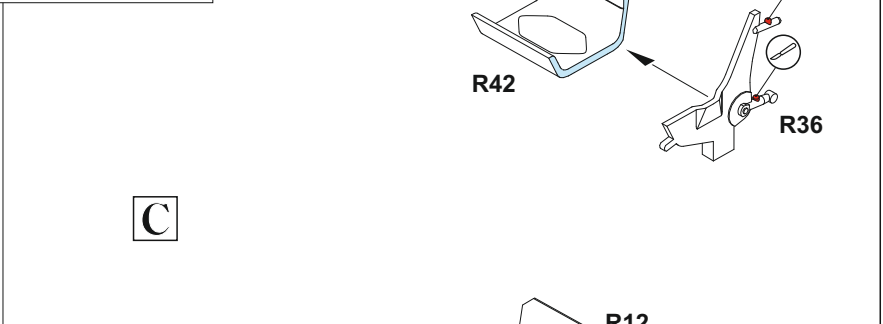
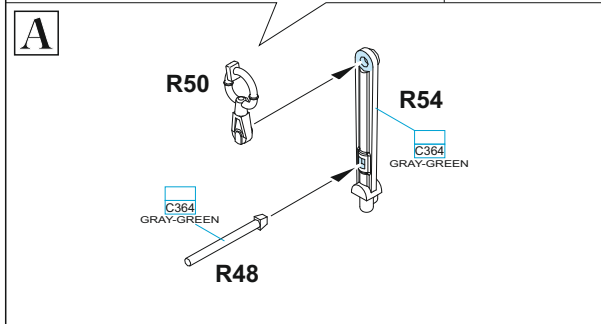
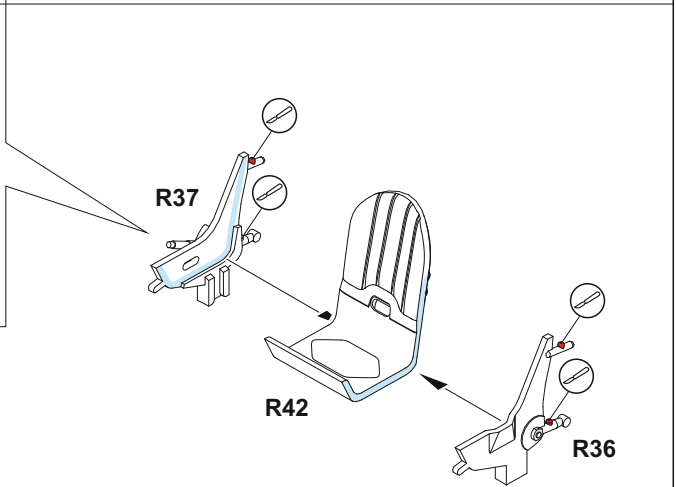
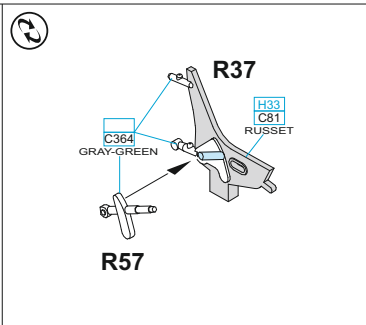
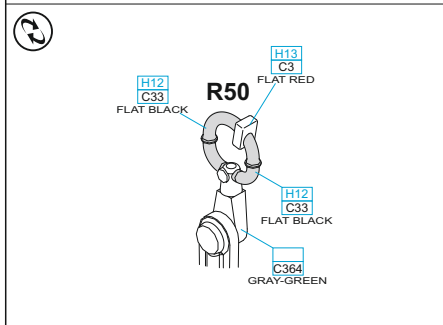
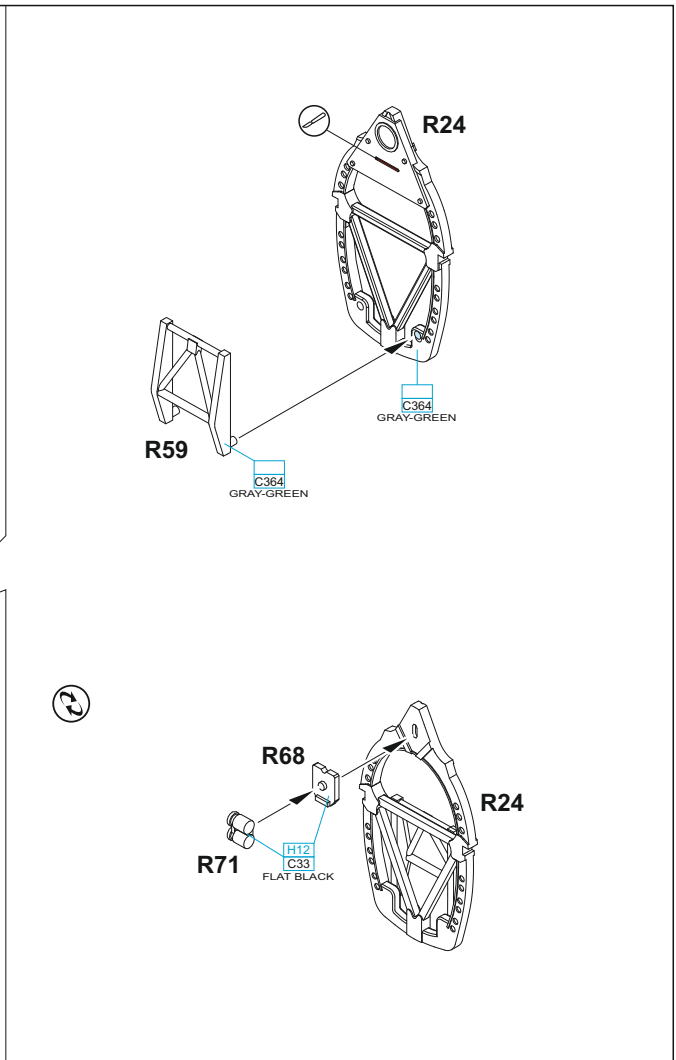
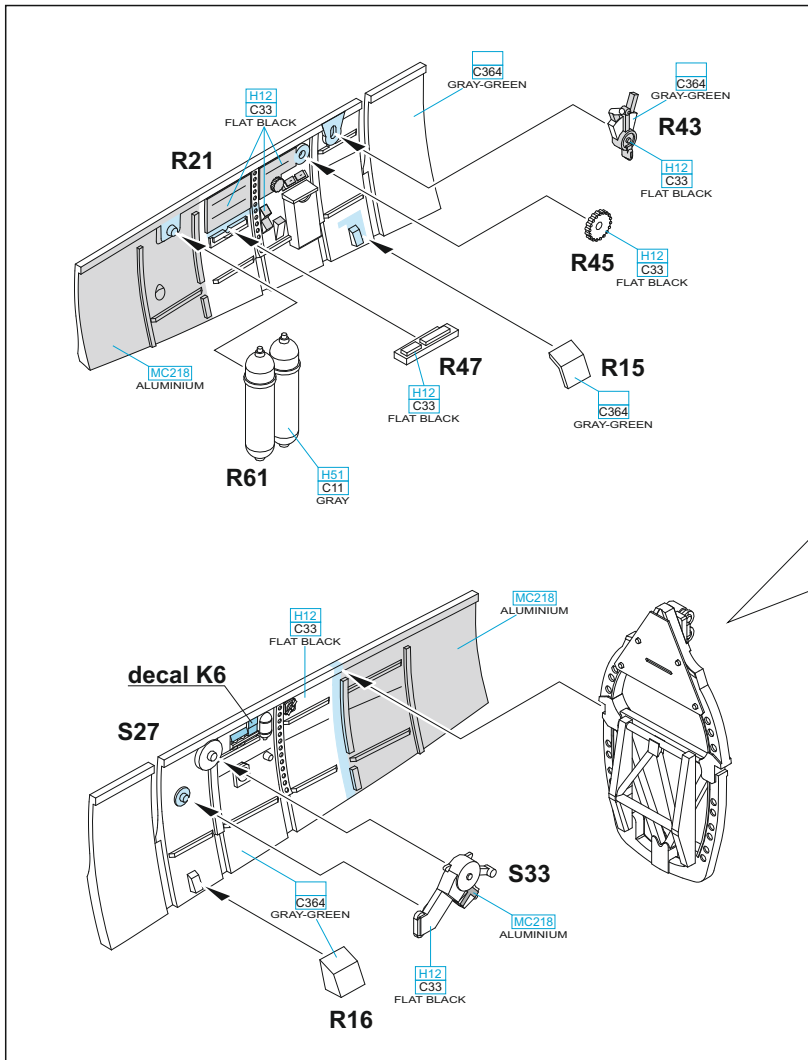

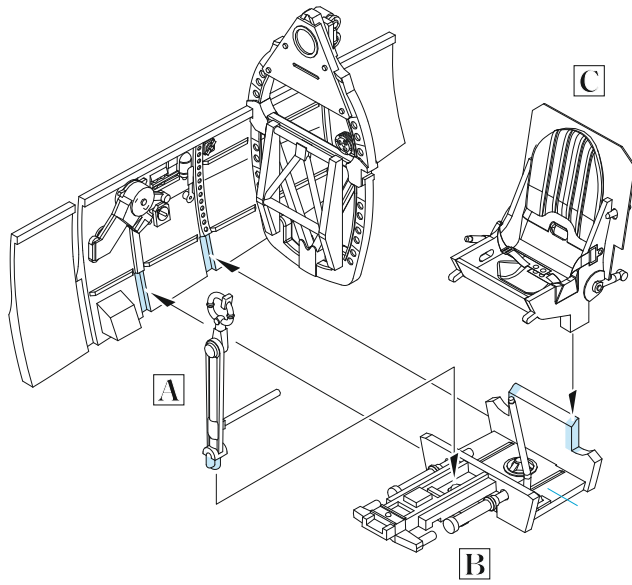

decal K9

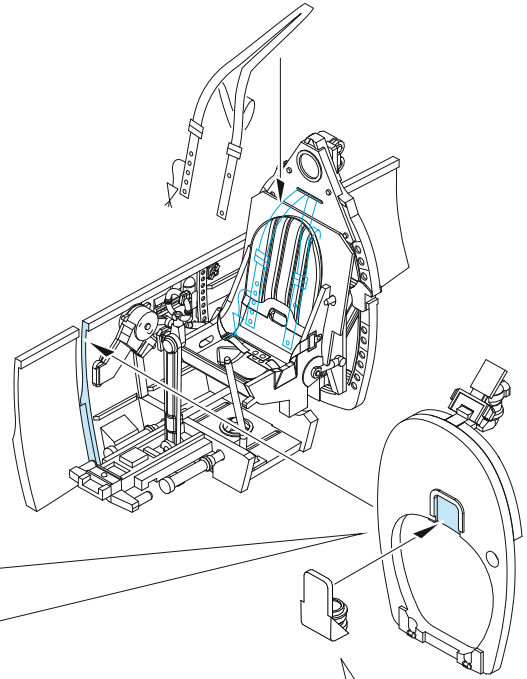

A1, A2 - MARKINGS B, C, D

A21 - MARKING A

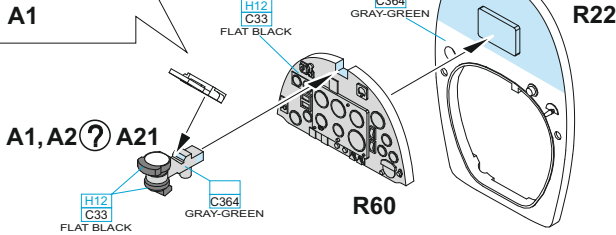
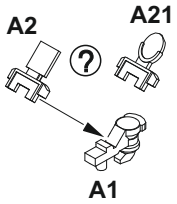

OPTIONAL: decals K1, K2, K3, K4

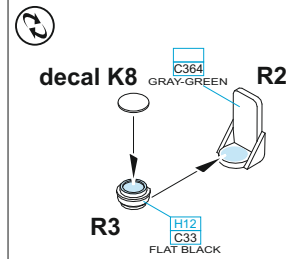

D

R55 - MARKING A ONLY

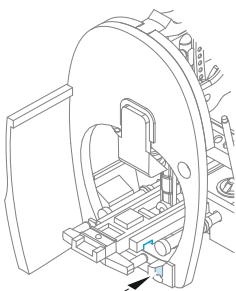

H12 C33 FLAT BLACK  
R55

R17

MC21B ALUMINIUM

R21

R17

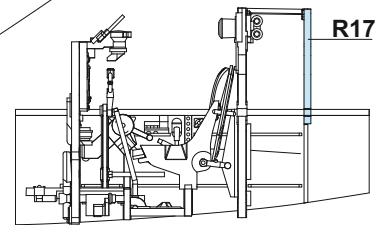

FOR CLOSED CANOPY ONLY

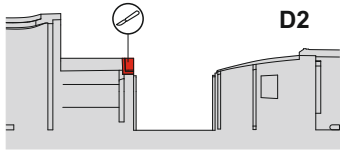

D2

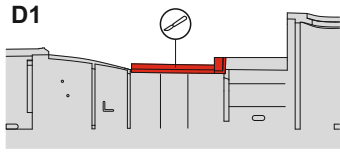

D1

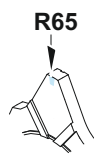

R65

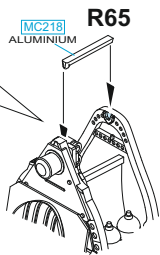

R65

MC218 ALUMINIUM

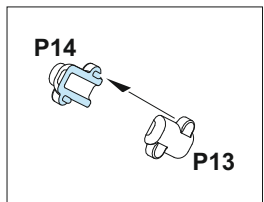

P14

P13

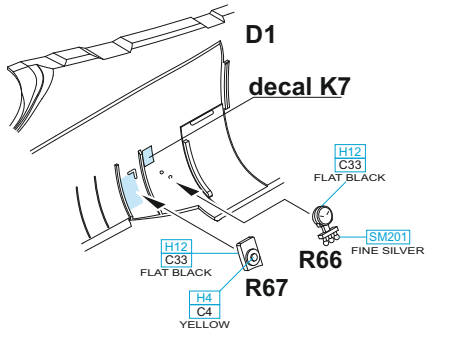
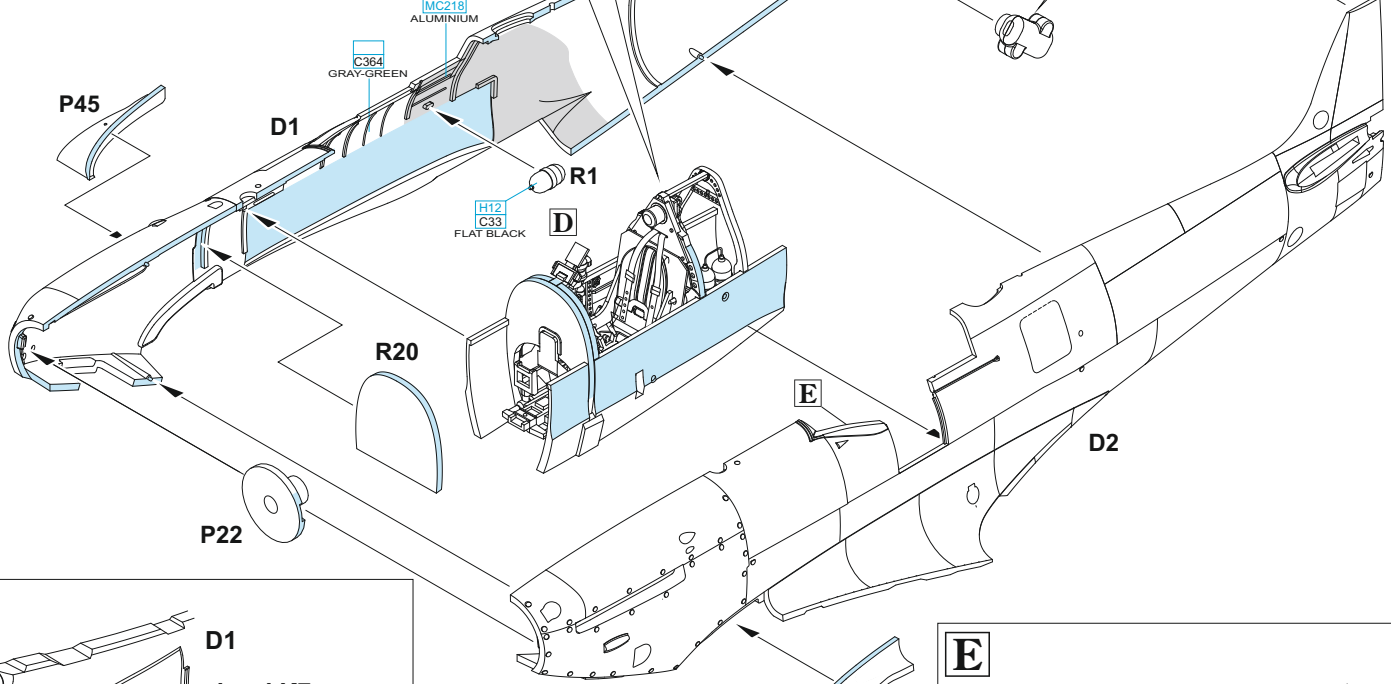

D1

decal K7

H12 C33 FLAT BLACK

H12 C33 FLAT BLACK

H4 C4 YELLOW

R66

SM201 FINE SILVER

R67

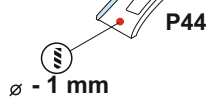

P44

∅ - 1 mm

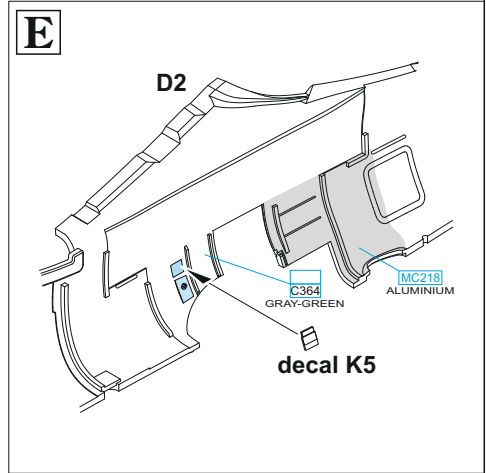

E

D2

decal K5

C364 GRAY-GREEN

MC218 ALUMINIUM

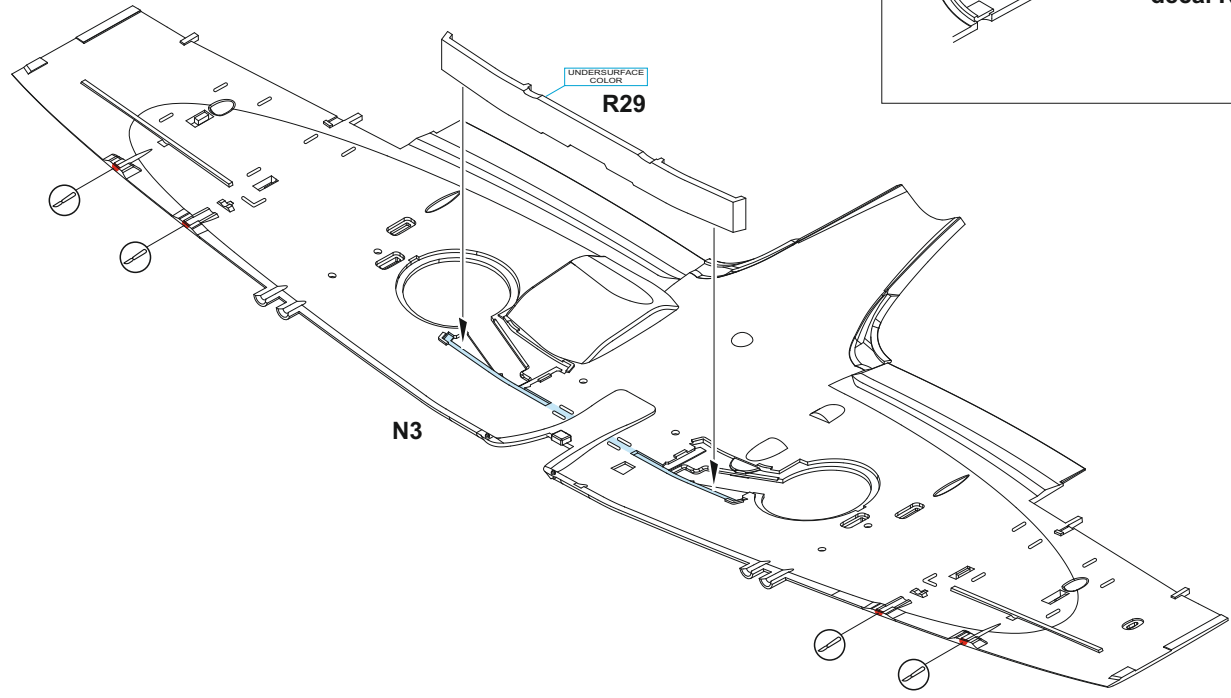

UNDERSURFACE COLOR

R29

N3

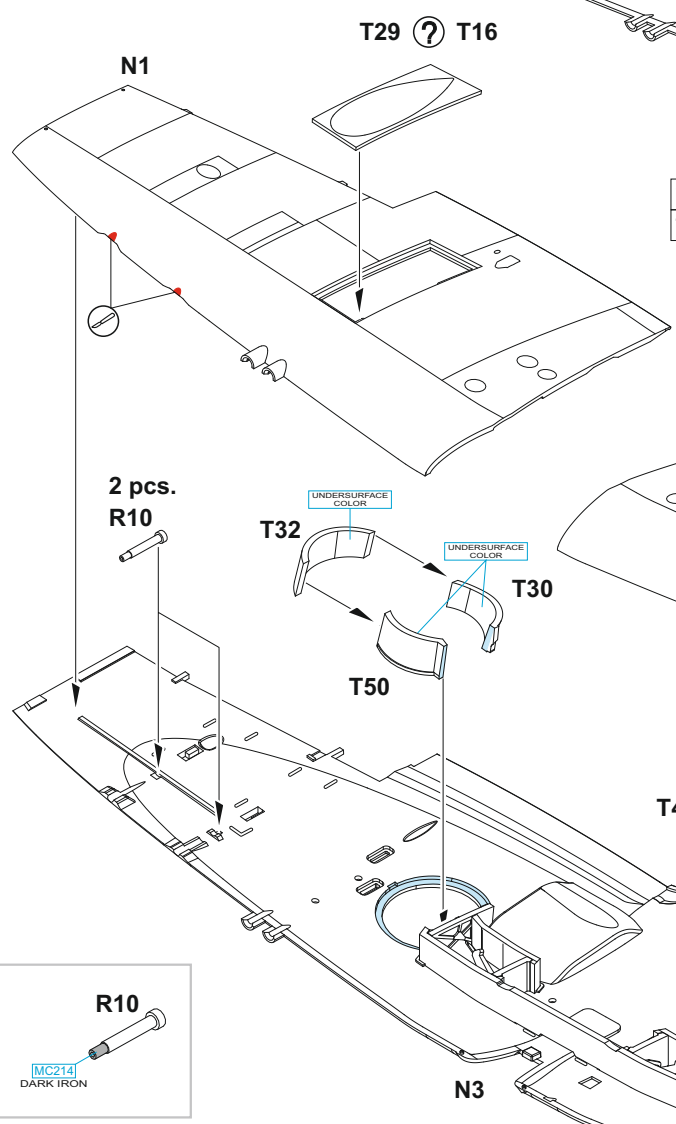
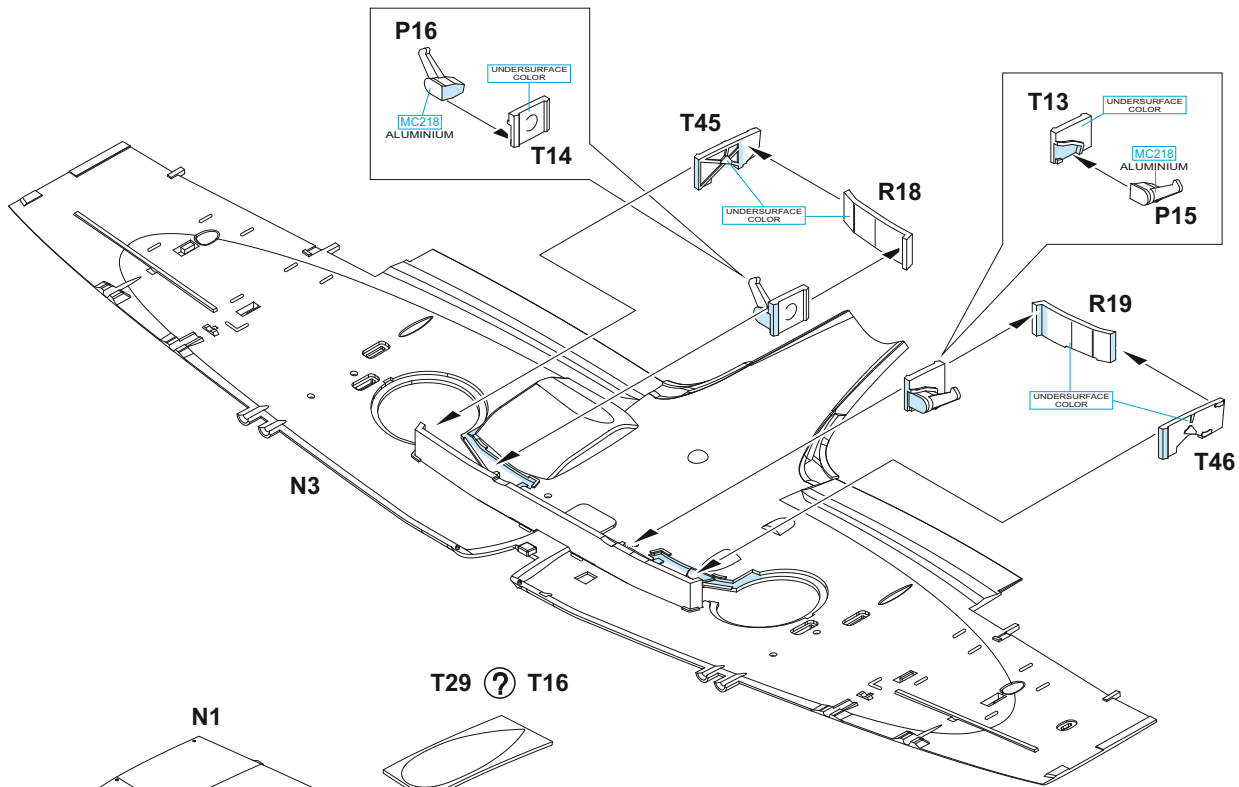

T16, T18 - MARKINGS **B, C, D**  
 T29, T31 - MARKING **A**

T31 (with a question mark) T18

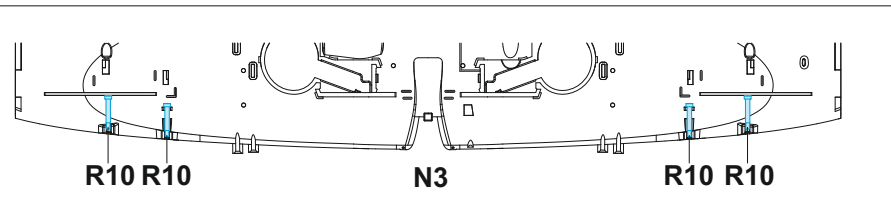
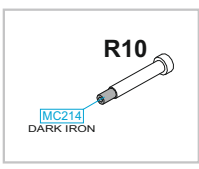

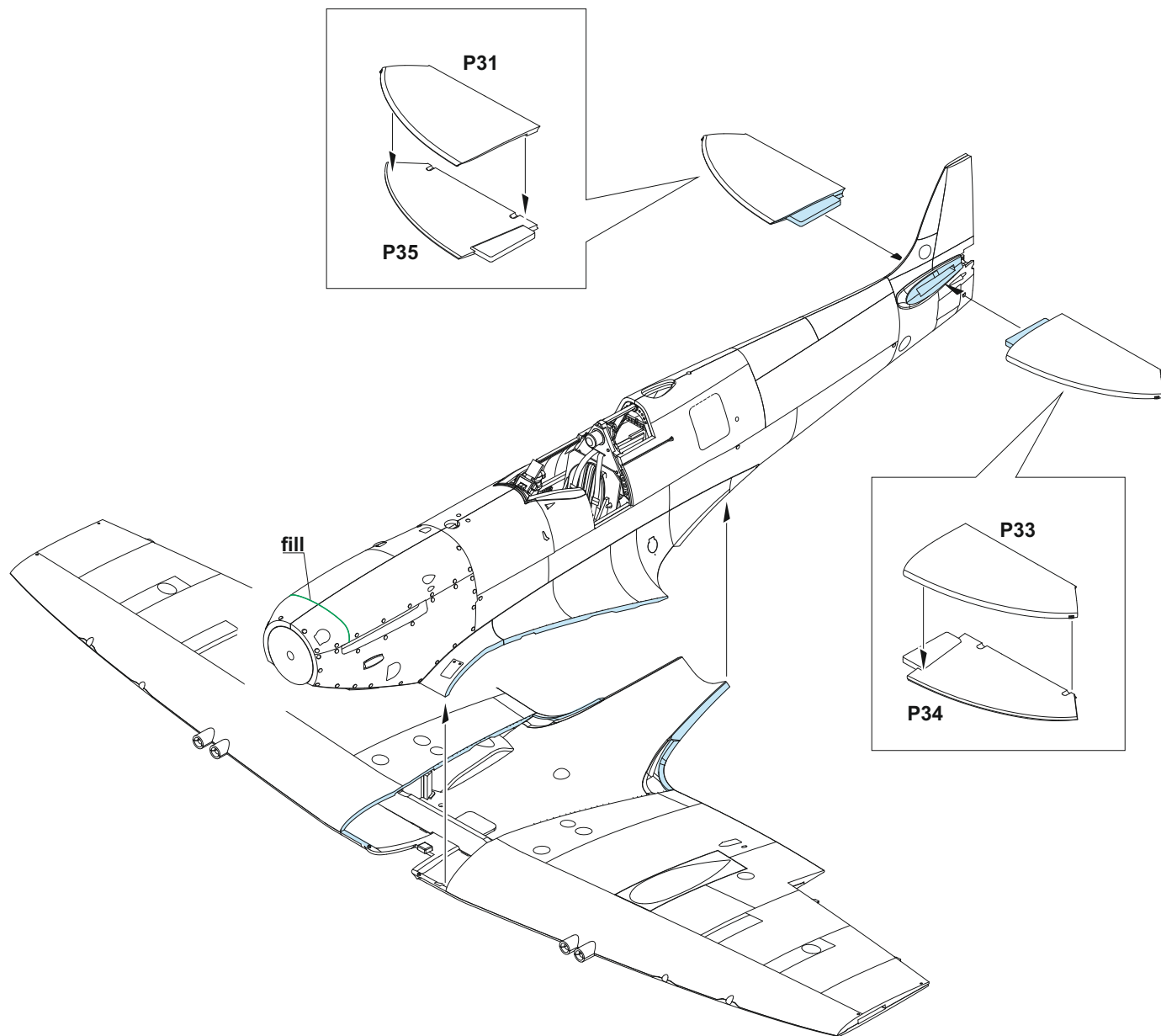

**GLUE PARTS P40 & P41  
ONE BY ONE**

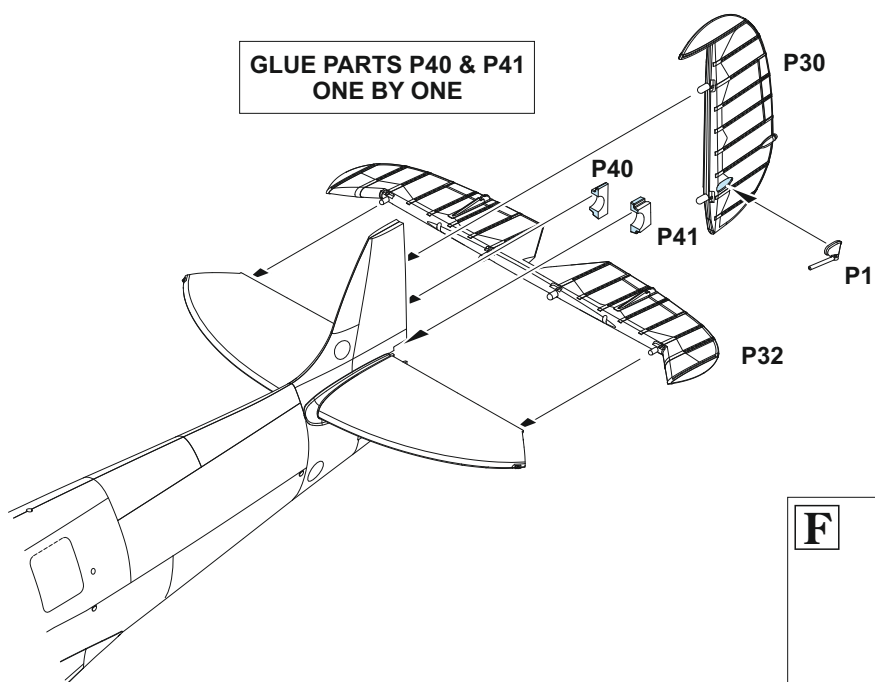

**F**

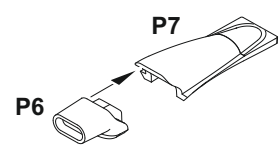

P25

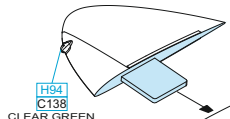

H94  
C138  
CLEAR GREEN

?

H94  
C138  
CLEAR GREEN

P70 ? A17

S21

A17 ? P70 - MARKINGS B, C ONLY

S18

G

T11 ? S10

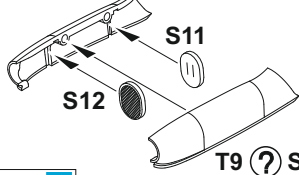

S9, S10 - MARKING A

T9, T11 - MARKINGS B, C, D

P28

H90  
C47  
CLEAR RED

?

A4 ? P69

H90  
C47  
CLEAR RED

A4 ? P69 - MARKINGS B, C ONLY

UNDERSURFACE  
COLOR

UNDERSURFACE  
COLOR

P26

P18

P54

P52

UNDERSURFACE  
COLOR

P20

P74

UNDERSURFACE  
COLOR

UNDERSURFACE  
COLOR

F

P29

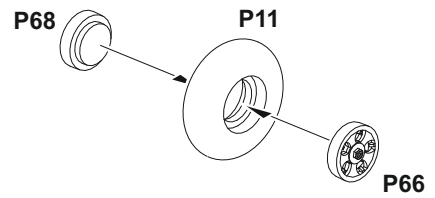
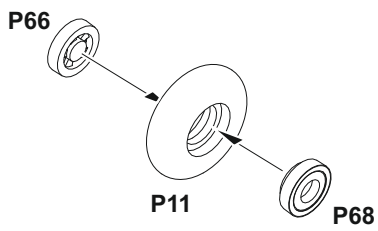
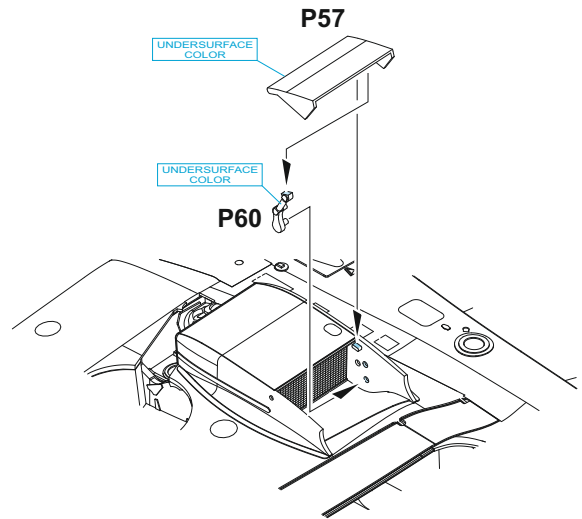
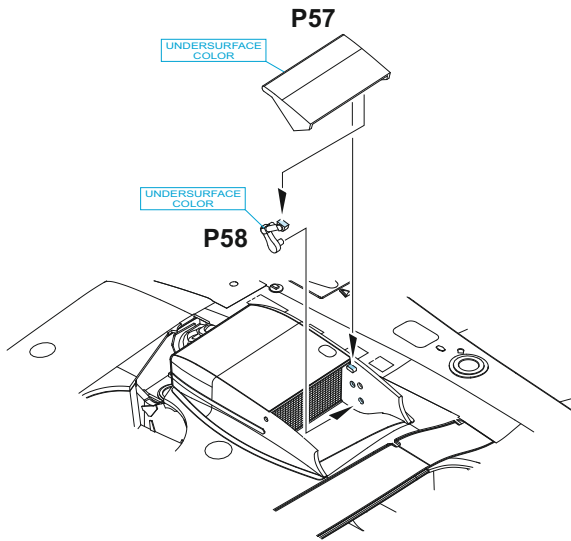
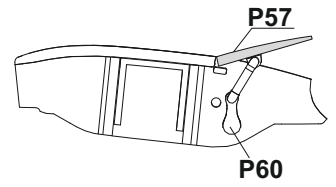
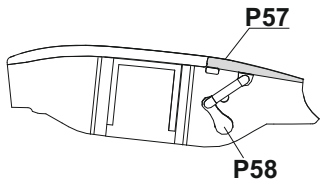

**H**

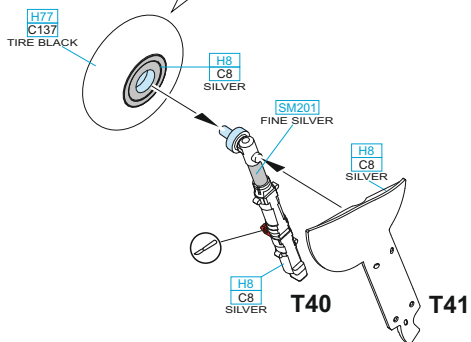

**I**

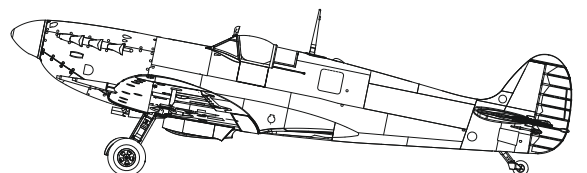
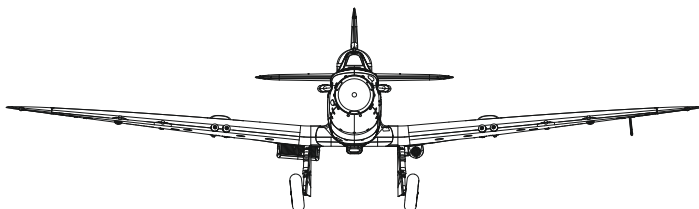
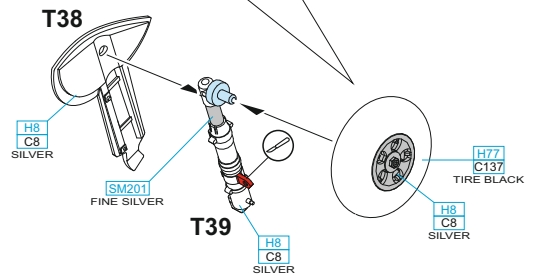

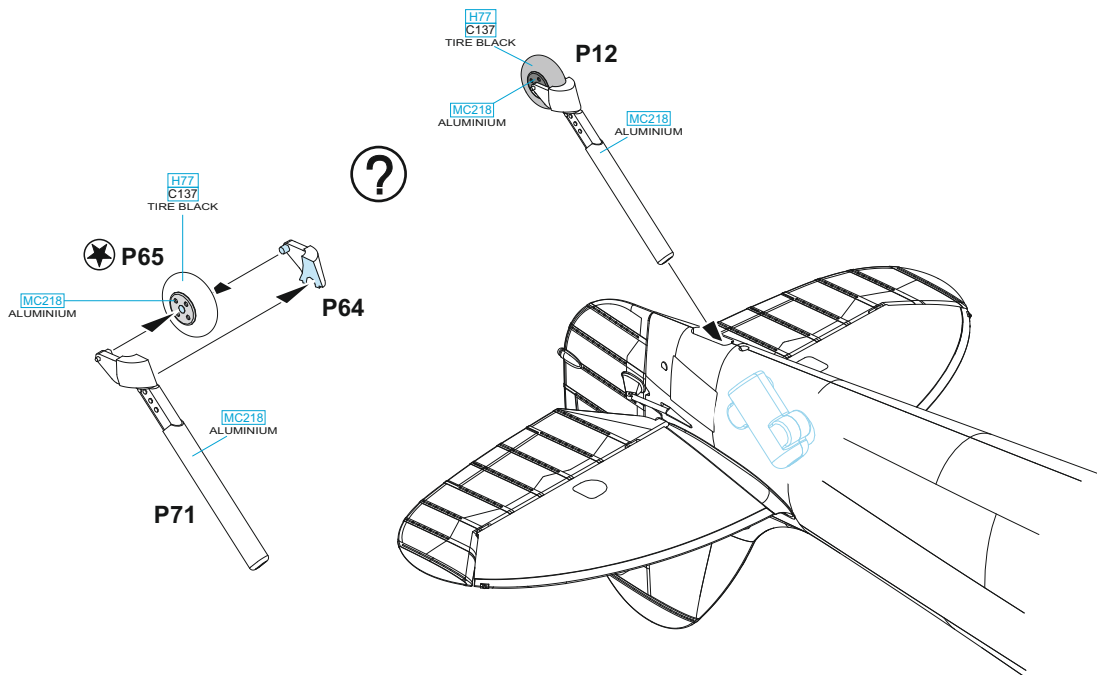
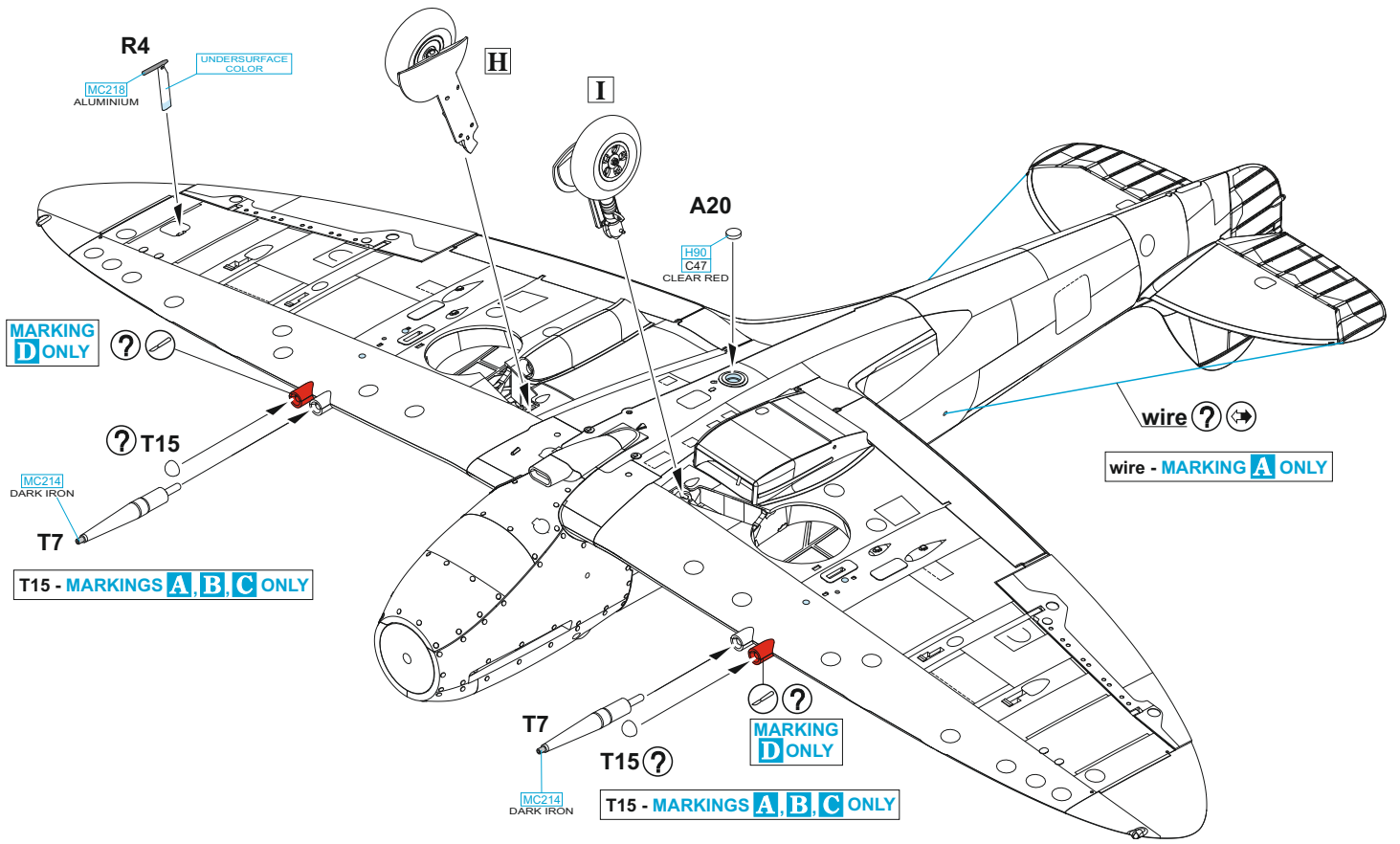



# A AB216, S/Ldr Robert W. Oxpring, No. 91 "Nigeria" Squadron, RAF Hawkinge, Great Britain, April–June 1942

Spitfire serial number AB216 was one of the first Mk.Vc Spitfires manufactured. From the mid-March 1942 it flew with the No. 91 "Nigeria" Squadron where it was a personal mount of S/Ldr Rober Oxpring who saddled it until June 1942. After its service with No. 91 Squadron, Spitfire AB216 was withdrawn from the operational flying and a towing device was installed on the tail wheel. Then it was tested for towing the Hotspur and Horsa gliders. Bobby Oxpring was born on May 22, 1919 in Sheffield, Yorkshire and during the Great War, his father had flown with an air reconnaissance unit. In March 1938, Oxpring joined RAF and as early as in December was transferred to the No. 66 Squadron, the same unit his father had flown with. He flew with this unit during the Battle of Britain where he scored eight confirmed victories a was decorated with DFC. In April 1941 he finished his tour of duty and was transferred to the No. 59 OTU where he flew as an instructor. In September 1941 he started his second tour of duty with the No. 616 Squadron but a week later he was ordered to the No. 41 Squadron where he led a flight. In January 1942 he assumed command of the No. 91 "Nigeria" Squadron and in June the command of the No. 72 Squadron where he was awarded a bar to his DFC. In November 1942 the unit was relocated to the North Africa where it was, as one of the first units, equipped with the new Spitfires Mk.IX. During the first months of 1943, Oxpring scored further five victories and one of his victims was the famous German ace Anton Hafner from JG 51. Having received the second bar to his DFC in the end of April, he finished his second tour of duty and was transferred to the No. 242 Group Headquarters. In the end of the year he returned to Great Britain and was assigned to the Fighter Command Headquarters. In March 1944 he commenced his third tour of duty as a Wing Commander with the No. 24 Wing flying Spitfires Mk.XIV and during June and July he shot down five V-1 flying bombs. In September he was ordered to the No. 141 Wing and then to the Detling Wing. He finished his wartime service with 14 confirmed kills, two probable, 13 aircraft damaged and five V-1 flying bombs destroyed.

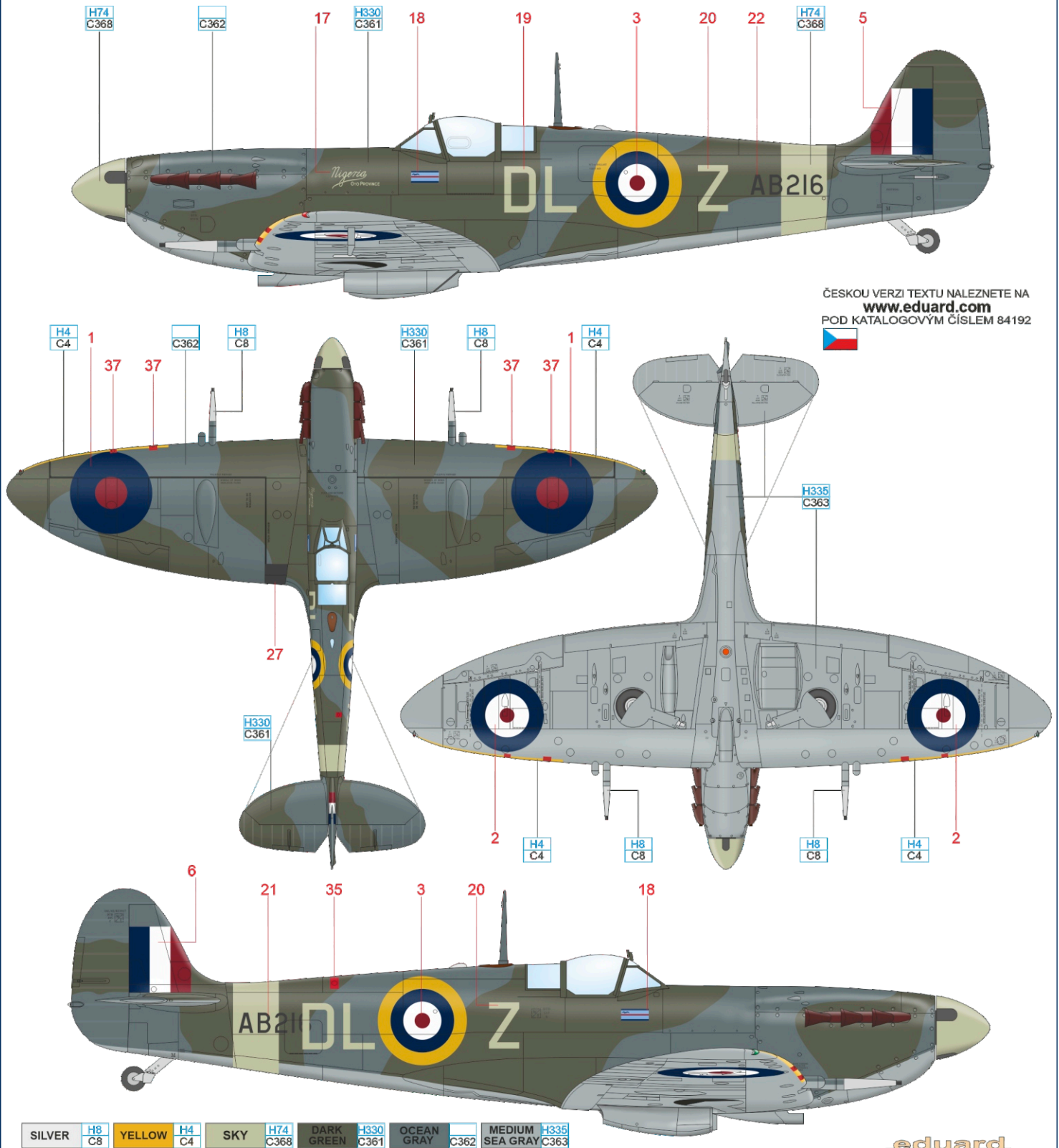

# B EE613, S/Ldr Michel G. B. Donnet, No. 350 Squadron, RAF Friston, Great Britain, June 1944

Mike Donnet was born in 1917 in Richmond, Great Britain. On March 1, 1938, he joined the Aviation Militaire Belge. He flew a Renard R.31 reconnaissance airplane with 9/V/1Ae based at Bierset. After the German invasion of Belgium on May 10, 1940, he flew several combat missions. After his country was occupied, he decided to flee and during the night of July 4-5 he managed to reach the Great Britain on a stolen Stampe SV-4b. On July 24, 1941, Michel Gabriel Libert Donnet was admitted to the ranks of the RAF and assigned to the No. 61 OTU to train on Spitfires. In September 1941, he was transferred to the No. 64 Squadron. Flying with this unit he took part in the missions against the Scharnhorst and Gneisenau battle cruisers and in the operation Jubilee at Dieppe. In 1943 he assumed command of the No. 64 Squadron. On March 23, 1944, he assumed command of the No. 340 Squadron and participated in the Normandy landing flying Spitfires Mk.Vc and IX. After the No. 350 Squadron converted to Spitfires Mk.XIV he flew missions against V-1 flying bombs, retreating German ground forces and providing the air cover at Arnhem. He led the unit until October 23, 1944, when he was decorated with DFC and promoted to the Wing Commander. In the beginning of 1945, he assumed command of the Hawkinge and Bentwater Wings flying Mustangs Mk.III. Leading the unit, he provided escort for the Mosquitos attacking the Gestapo Headquarters in Copenhagen. During his wartime career, Donnet flew 375 missions achieving the score of three confirmed kills, one probable and four damaged, all while flying with the No. 64 Squadron. After the war he served at the Belgium Department of Defense and reorganized the Belgium Air Force for the new jet equipment. Then he was given the job as a Chief of Staff of the 2<sup>nd</sup> Allied Tactical Air Force responsible for the Western Europe AA defense. In 1972 General Lieutenant Donnet was appointed the Belgium Military Attache at NATO. On June 1, 1975, he retired from the Belgium AF with the rank of General Lieutenant having logged 5000 flight hours. In 1968 he published a book about his many famous adventures titled "J'ai volé la liberté" (a Flight to Freedom).

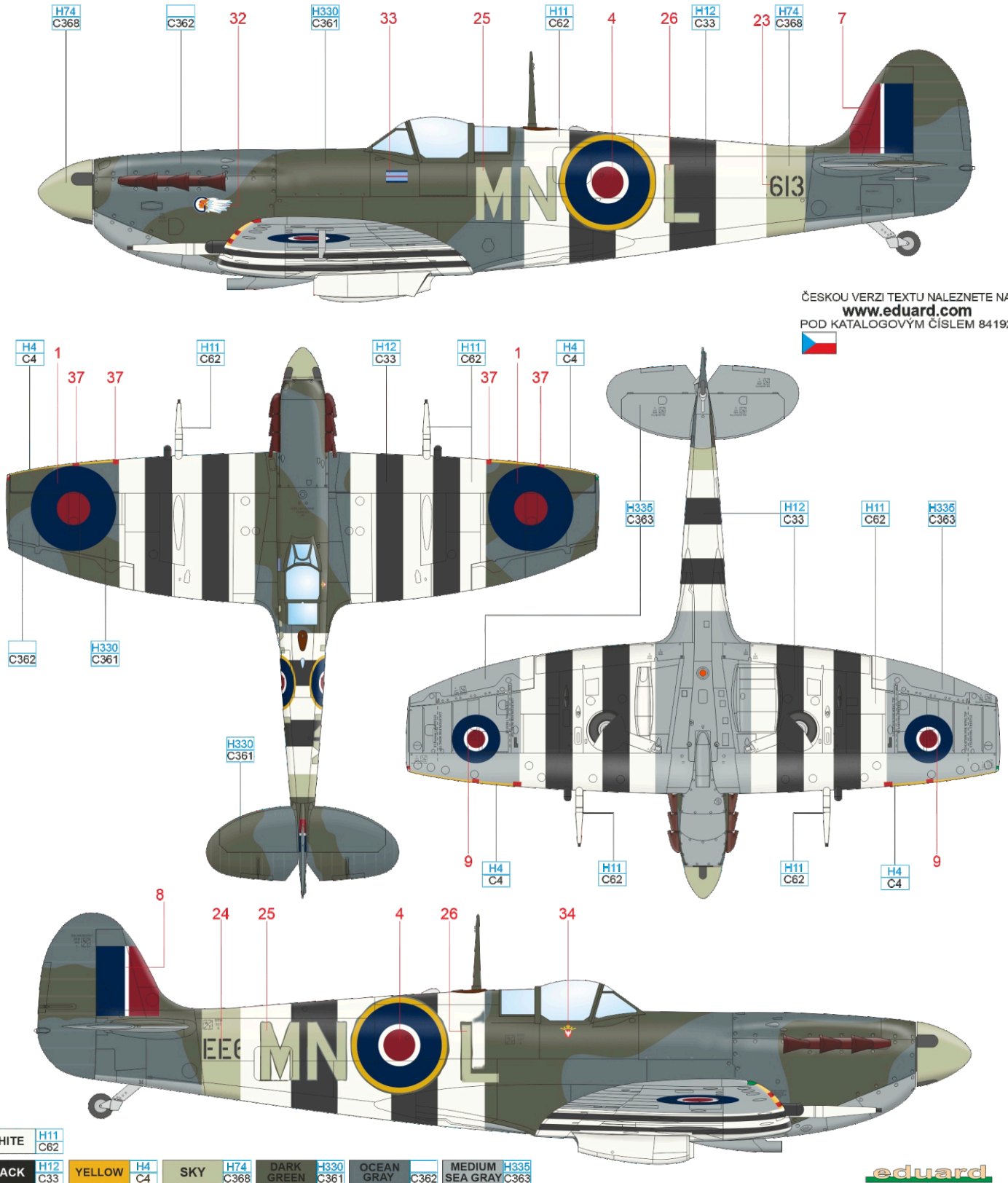

Spitfire Mk.Vc carrying a white inscription Julie II on the starboard engine cowling featured the clipped wings and according to the memoirs of its pilot, Bob Curtis, it sported a non-standard camouflage of two shades of green, probably Dark Green and Olive Drab, on the upper surfaces. On February 19, 1944, Bob Curtis at its controls, shot down a Bf 109 and his opponent was most probably Oblt. Klippigen from 7./JG 53. Several days later he lost his Spitfire when the target he was attacking exploded and damaged his aircraft. After the 52<sup>nd</sup> FG converted to P-51 Mustangs, Curtis shot down another 13 enemy airplanes. After the war, until 1950, he served with USAF Reserves as a Meteorological Officer.

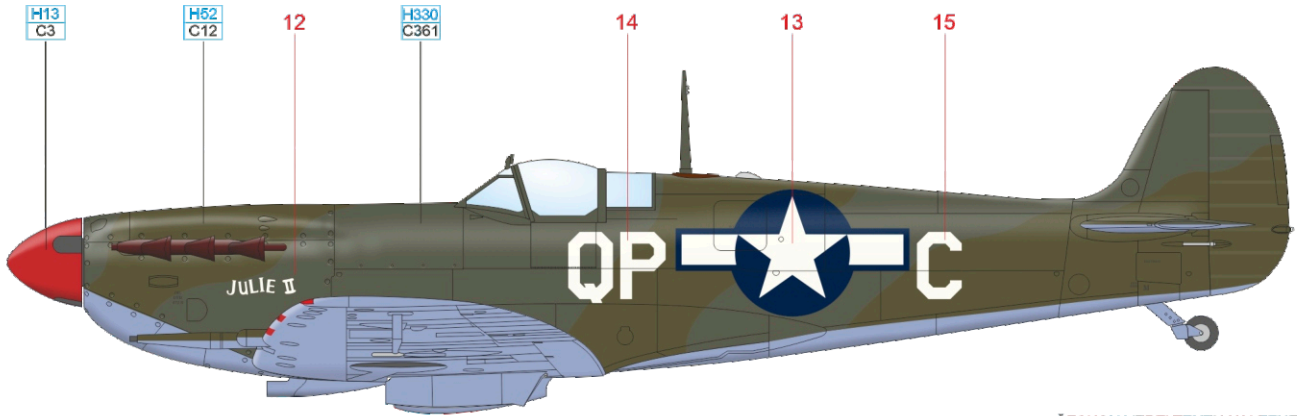

ČESKOU VERZI TEXTU NALEZNETE NA [www.eduard.com](http://www.eduard.com)  
 POD KATALOGOVÝM ČÍSLEM 84192

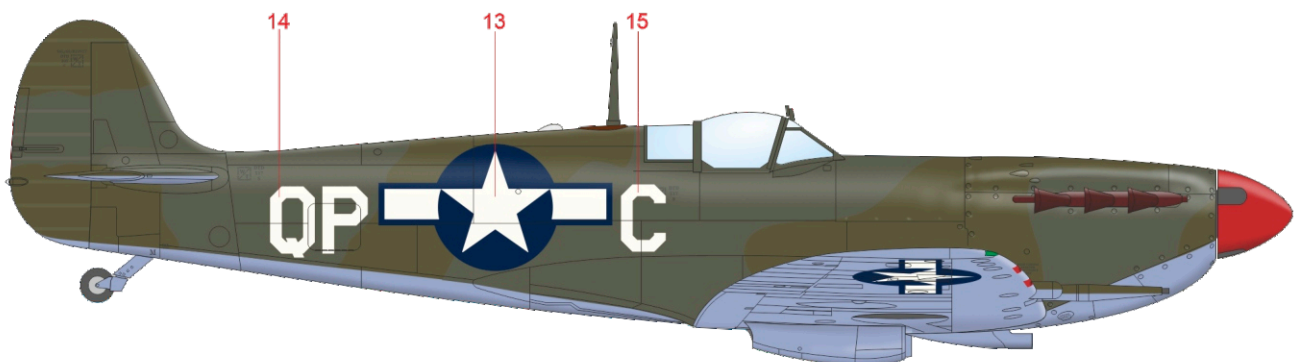
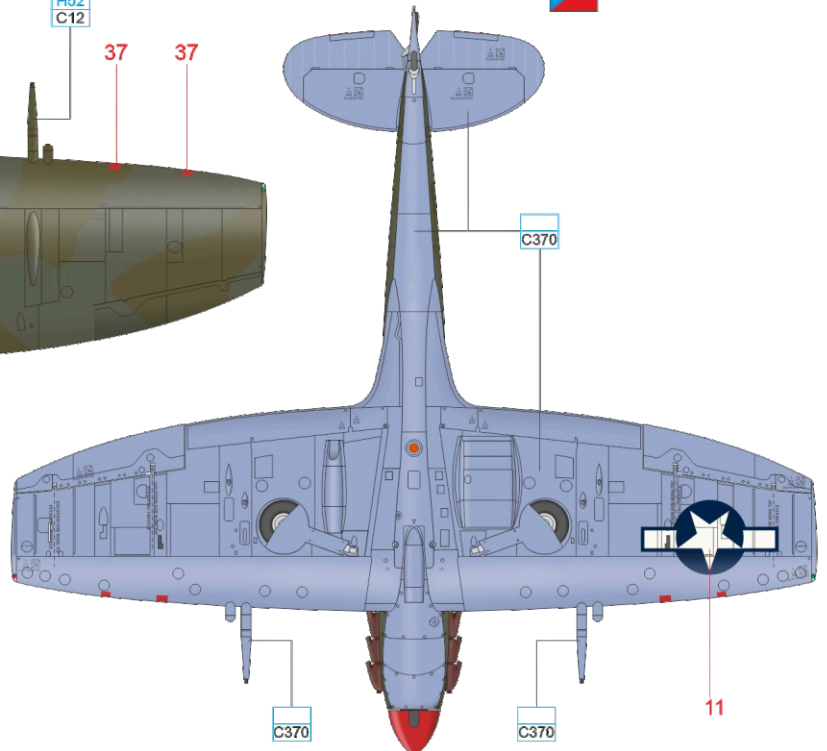
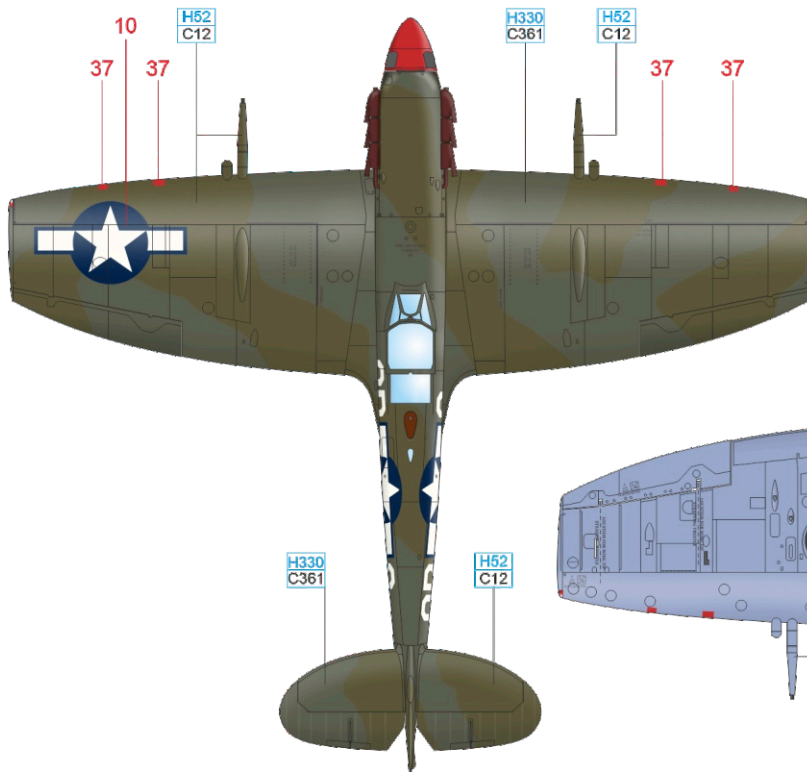

# D JK661, Cne. Georges Valentin, No. 326 Squadron (GC.II/7), Armée de l'Air, Corsica, September 1943

Georges Valentin was born on May 19, 1908, in La Ville, France. Since the early childhood he was a passionate aviation fan and won a scholarship enabling him to attend the courses at the Richard Aviation School where on February 6, 1927 he obtained his pilot's licence. During that month, as a soldier he joined the 2<sup>nd</sup> group of the aviation workers in Istres. In the end of May he was attached to the 6e Escadrille 3e Regiment D'Aviation Mixte in Thionville. In November 1927 he was accepted to the professional warrant officers ranks. On April 1, 1933, he was promoted to S/C rank and in January 1936 he joined GC II/7. When on September 3, 1939, France declared war on Germany, Adj/Chef Valetin served as a pilot with 3. escadrille GC II/7 at the Luxeuil base equipped with MS.406. During the French campaign sous lieutenant Valentin flew 27 combat missions during which he scored eight confirmed victories and one probable. One of his victims was a Do 17 from Stab./KG 77 with a KG 77 commander, Gen. Maj. Wolff von Stutterheim on board, who succumbed to his wounds. After the armistice Valentin remained with the unit. After the Anglo-American landing and surrender of the French troops in Africa (operation "Torch") his unit converted to Spitfires Mk.V a was renamed GC 2/7 "Nice". In April 1943 the unit participated the final stage of the Tunisian campaign and then liberation of Corsica. During these battles, in the fall of 1943, lieutenant Valentin scored three victories. On June 1, 1944, he was promoted to Capitaine and on June 6 he assumed command of the 1 escadrille GC 2/7 "Nice". In the beginning of September, the unit was relocated to France to support the Allied troops. On Friday September 8, 1944, around 5:20 pm, flying his 328<sup>th</sup> combat mission at a very low altitude, in Dijon sector, Capitaine Georges Valentin was shot down by a German AA fire. His Spitfire burst in flames and hit a house on Rue Auguste-Brulle nr. 12 in Dijon. Georges Valentin was a recipient of the Knight of Honorary Legion and Croix de Guerre decorated with seven palm trees and five stars. He flew 328 combat missions having logged 2,902 flight hours and was credited with eleven victories and two probable kills.

