

Spitfire Mk.Vb early

eduard

1/48 Scale Plastic Model Kit

WEEKEND
edition



item # 84198

The Supermarine Spitfire is so iconic, that virtually everyone can recognize it. The service of this elegant fighter spanned remarkable 13 years. It entered the service at the end of biplane era and remained on frontline duty until the jet age.

By the early 30s the RAF was looking for replacement of its ageing Hawker Fury biplane fighters. The need of considerably faster aircraft was obvious, as the racing monoplane floatplanes of that time were reaching about twice the speed of the Fury. One of the most successful designers of the racing floatplanes was Reginald J. Mitchell. His Supermarine S.6B raised the world speed record to 407 mph (655 km/h) on September 20, 1931, and British Air Ministry, under influence of such remarkable achievement, issued the specification F.7/30 in October 1931. Although it was calling for modern pursuit airplane capable of at least 250 mph (400 km/h), seven out of eight entries were biplane designs. The only monoplane proposal was Mitchell's Supermarine 224, but the aircraft with a gull wing, fixed undercarriage and Rolls-Royce Goshawk engine was a disappointment. Due to that, the Gloster Gladiator biplane was declared a winner.

Early work

The fiasco with Type 224 did not prevent Mitchell from further work. He persuaded the Supermarine company to fund the work on the completely new design Type 300 using the brand new Rolls-Royce PV12 engine, later known as the Merlin. The Air Ministry expressed interest and issued specification F.37/34 on December 28, 1934, to fund a prototype armed with four wing mounted guns. By early April 1935 Mitchell received the detail of specification F10/35, and it was calling for eight guns. The change was made on cost of bomb provision removal and reduction of the fuel tanks volume to sixty-six gallons. The decision caused the so called "short legs" of the Spitfire, meaning a lack of range and endurance.

The Supermarine Type 300 made its maiden flight on March 5, 1936, an initial contract to produce 310 Spitfires was signed in June 1936 and the first unit to receive the new fighter was No. 19 Squadron at Duxford in August 1938.

Searching for performance

The Spitfire's development was an ongoing process from very early stage of its service and incorporated many changes. From the early Mk.I and Mk.II the development reached the point, where a more substantial performance step was required.

After trials with the Merlin XX engine, installed in the prototype of the Spitfire Mk.III, Rolls-Royce offered a viable and quick solution in late 1940, the concurrently developed and simpler to manufacture Merlin RM5S engine (later designated Merlin 45). It featured one-stage single-speed compressor optimized for high altitudes. Its output at 17,700 ft (5,400 m) was 1,210 hp (902 kW).

The Merlin 45 was the same size as the Merlin III powering the Mk.I Spitfires, and its design allowed the Merlin III to be upgraded to the Merlin 45 by changing the supercharger. This facilitated the simple installation into the freshly built Spitfire Mk.I and Mk.II airframes and the conversion of the already manufactured aircraft as well.

First two converted Spitfires were test-flown at Boscombe Down, where a maximum speed of 593 kph at 20,000 ft (6,100 m) was recorded during the flight tests. The trials also brought out the problems with the De Havilland constant-speed propeller as oil of its control system was freezing at high altitudes. There were troubles with Mk.II oil cooler as well as it was not efficient enough for the more powerful engine. Even though this was considered an interim solution, as the Spitfire Mk.III production was still being planned, the order for new Spitfires was placed, or, better said, the program for converting Spitfires Mk.I and Mk.II into Spitfires Mk.V was ordered. Finally, 6464 Spitfires Mk.V of all variants were manufactured.

This kit: Spitfire Mk.Vb early

In the middle of March 1941, Spitfire X4922 built in Eastleigh at Spitfire Mk.I assembly line, arrived at Boscombe Down. It already featured Merlin 45 and was test-flown on February 7. During the trials it was fully armed and equipped and reached the maximum speed of 374,7 mph (603 kph). In Eastleigh, in the second half of February, a total of 23 Spitfire Mk.I airframes, mostly version Mk.Ib, received Merlin 45, thus becoming the first Spitfires Mk.Vb armed with four .303 machine guns and two 20mm cannons. This mark was the most produced, while there were only 94 of eight wing .303 machine guns Spitfires Mk.Ia produced. The Mk.Vc had usually the same armament as the Mk.Vb although with possibility to be armed with four 20mm cannons.

Besides the engine, the equipment of these aircraft corresponded to Spitfire Mk.I standard including the smaller oil cooler with U-shaped intake which was the cause of higher oil temperature of the first Spitfires Mk.V and posed a certain risk of engine overheating.

During the two and half years of Spitfire Mk.V production, the airframe was gradually developed. Already at the beginning of manufacture they featured thicker armor in comparison to Mk.I and Mk.II. The oil cooler was soon replaced with a larger one featuring a circular intake which was retroactively installed on the first batch of Spitfires Mk.V, converted from Mk.I and Mk.II, and became one of the features distinguishing Spitfires Mk.V.

ATTENTION



UPOZORNĚNÍ



ACHTUNG



ATTENTION



注意



Carefully read instruction sheet before assembling. When you use glue or paint, do not use near open flame and use in well ventilated room. Keep out of reach of small children. Children must not be allowed to suck any part, or pull vinyl bag over the head.



Před započatím stavby si pečlivě prostudujte stavební návod. Při používání barev a lepidel pracujte v dobře větrané místnosti. Lepidla ani barvy nepoužívejte v blízkosti otevřeného ohně. Model není určen malým dětem, mohlo by dojít k požití drobných dílů.

INSTRUCTION SIGNS * INSTR. SYMBOLS * INSTRUKTION SINNBILDEN * SYMBOLES * 記号の説明

OPTIONAL
VOLBABEND
OHNOUTSAND
BROUSITOPEN HOLE
VYVRTAT OTVORSYMETRICAL ASSEMBLY
SYMETRICKÁ MONTÁŽREMOVE
ODŘÍZNOUTREVERSE SIDE
OTOČITAPPLY EDUARD MASK
AND PAINT
POUŽÍT EDUARD MASK
NABARVITPLEASE CHECK THE LATEST VERSION OF THE INSTRUCTIONS ON www.eduard.com

PARTS



DÍLY



TEILE



PIÈCES



部品

PLASTIC PARTS

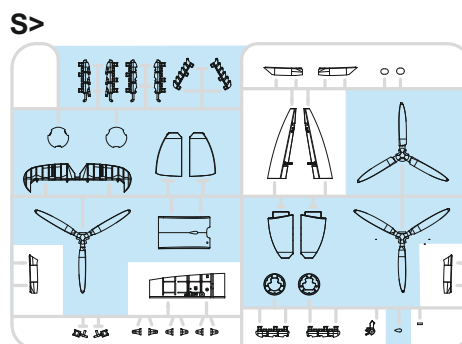
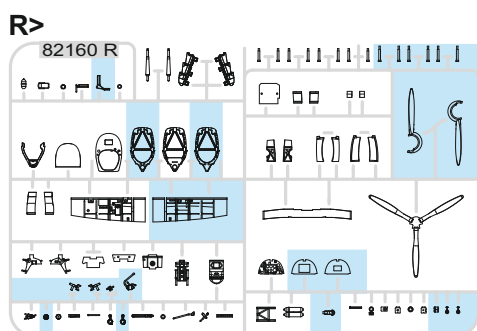
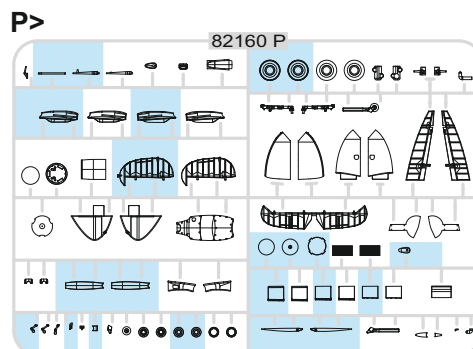
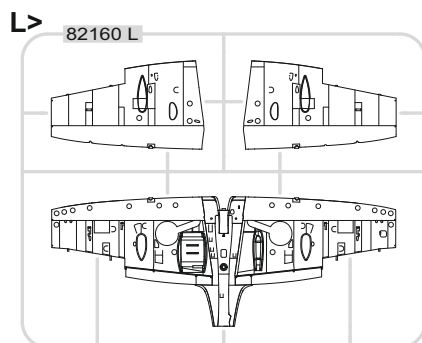
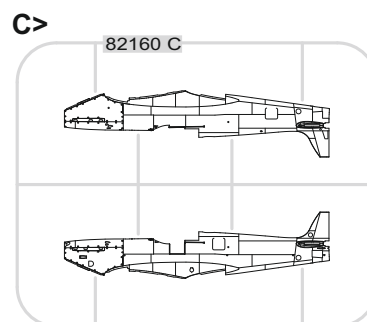
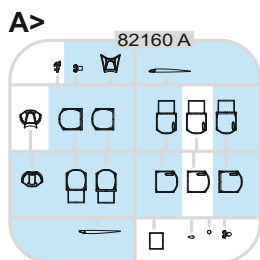

-Parts not for use. -Teile werden nicht verwendet. -Pièces à ne pas utiliser. -Tyto díly nepoužívejte při stavbě. - 使用しない部品

COLOURS



BARVY



FARBEN



PEINTURE



色

GSI Creos (GUNZE)		
AQUEOUS	Mr.COLOR	
H2	C2	BLACK
H3	C3	RED
H4	C4	YELLOW
H11	C62	FLAT WHITE
H12	C33	FLAT BLACK
H33	C81	RUSSET
H47	C41	RED BROWN
H51	C11	LIGHT GULL GRAY
H72	C369	DARK EARTH
H74	C368	SKY
H77	C137	TIRE BLACK
H84	C42	MAHOGANY
H90	C47	CLEAR RED

GSI Creos (GUNZE)		
AQUEOUS	Mr.COLOR	
H94	C138	CLEAR GREEN
H330	C361	DARK GREEN
H333	C333	EXTRA DARK SEAGRAY
H335	C363	MEDIUM SEAGRAY
H417	C117	RLM76 LIGHT BLUE
	C362	OCEAN GRAY
	C364	AIRCRAFT GRAY-GREEN
Mr.METAL COLOR		
	MC214	DARK IRON
	MC218	ALUMINIUM
Mr.COLOR SUPER METALLIC		
	SM201	SUPER FINE SILVER

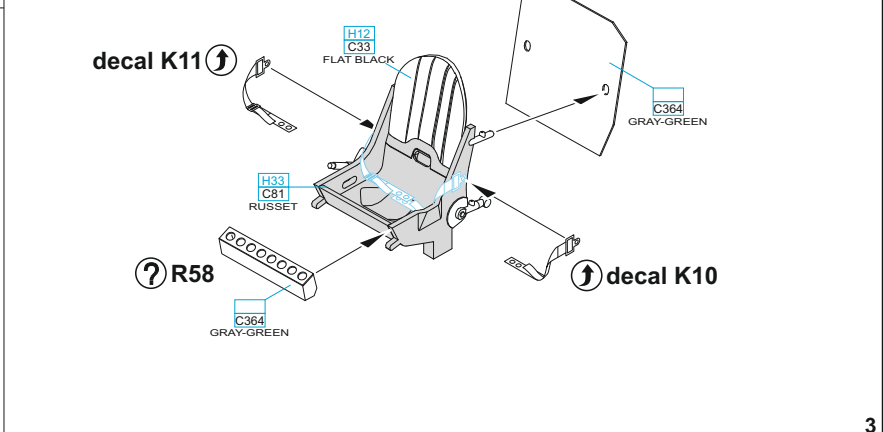
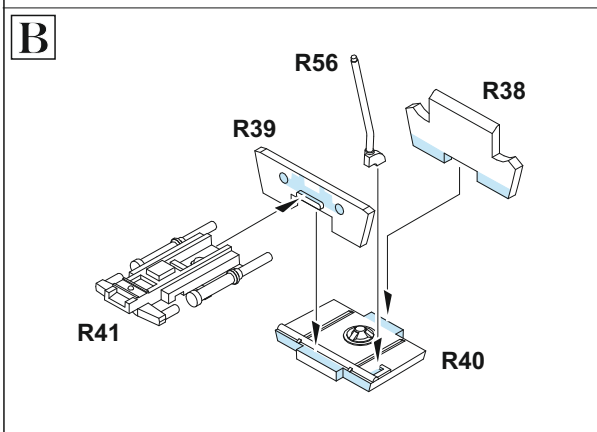
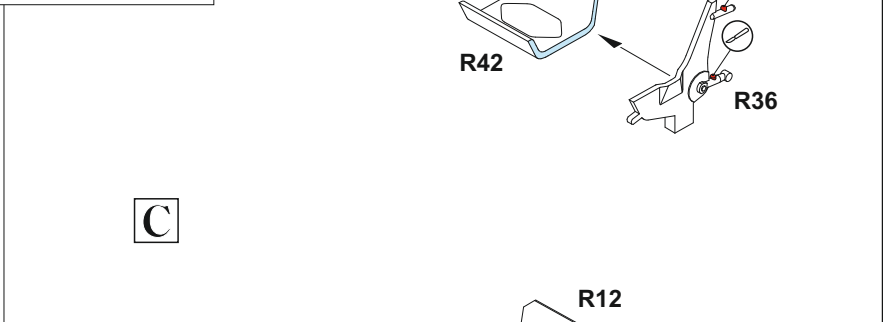
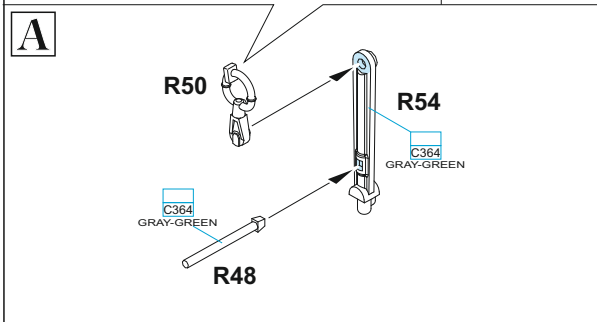
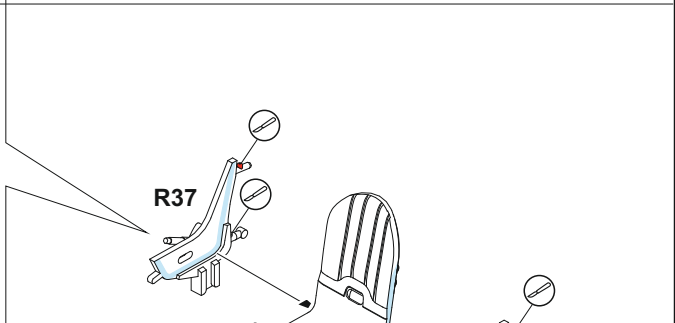
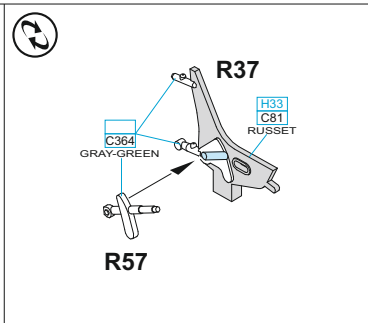
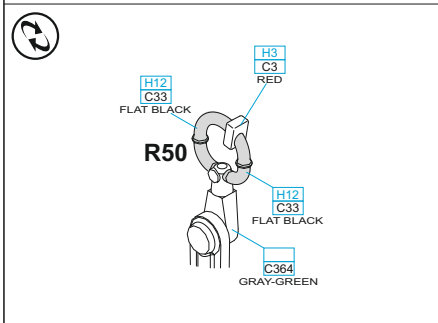
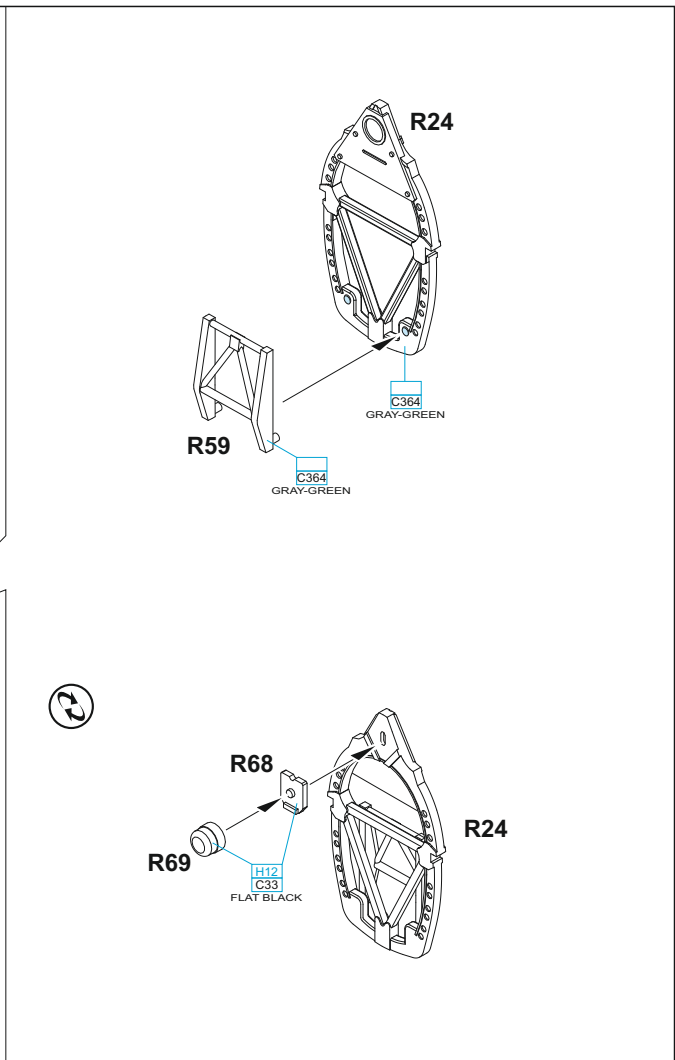
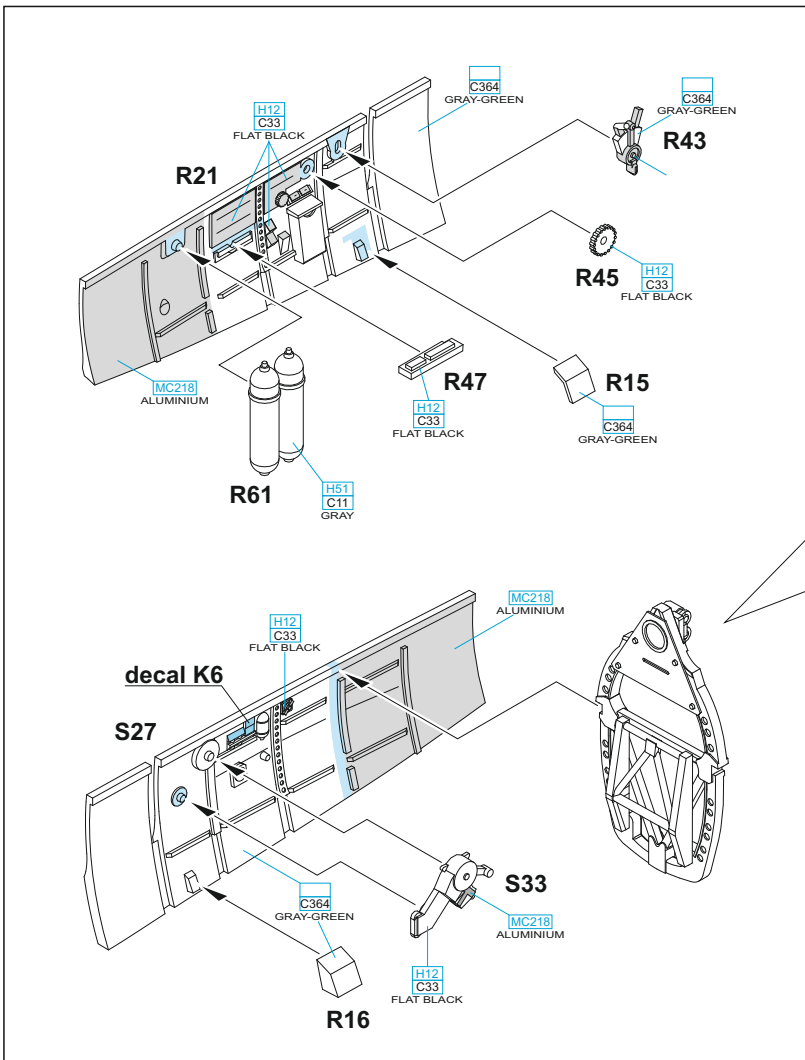

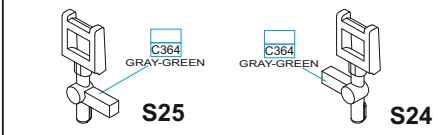
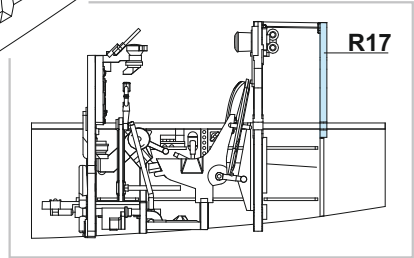
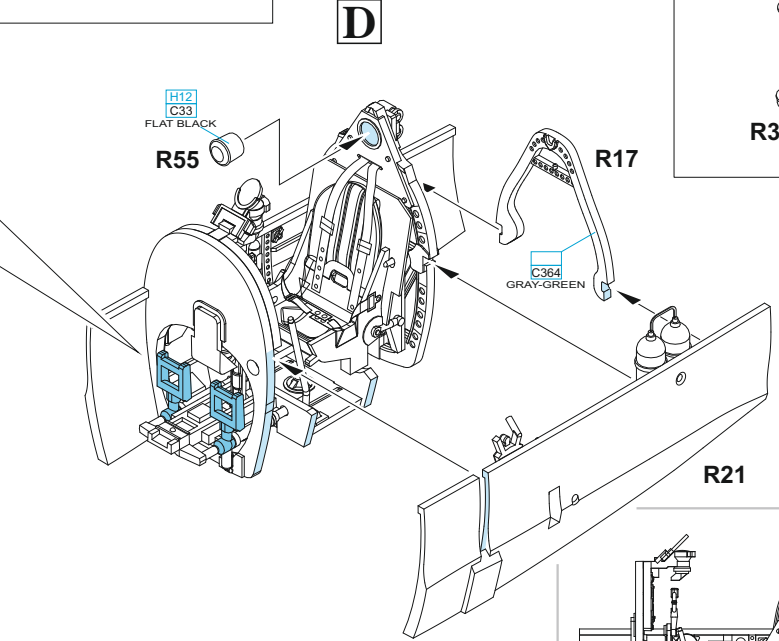
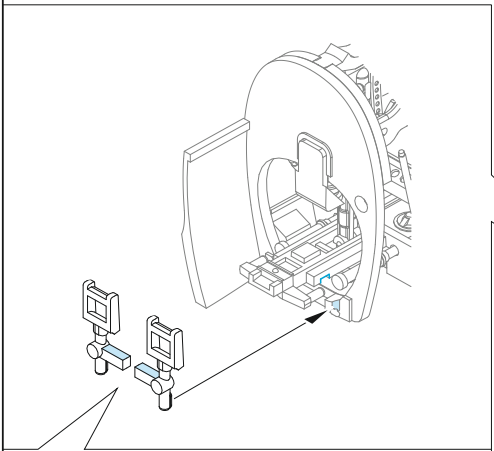
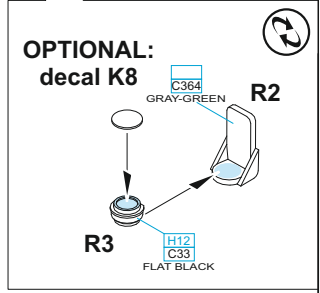
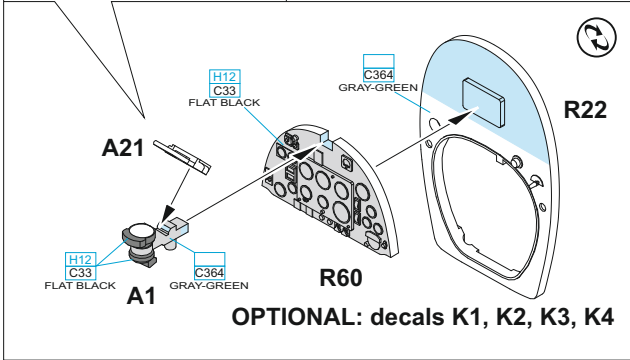
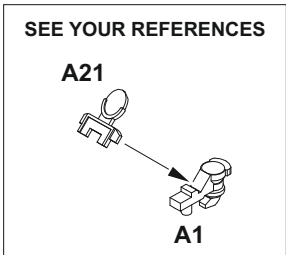
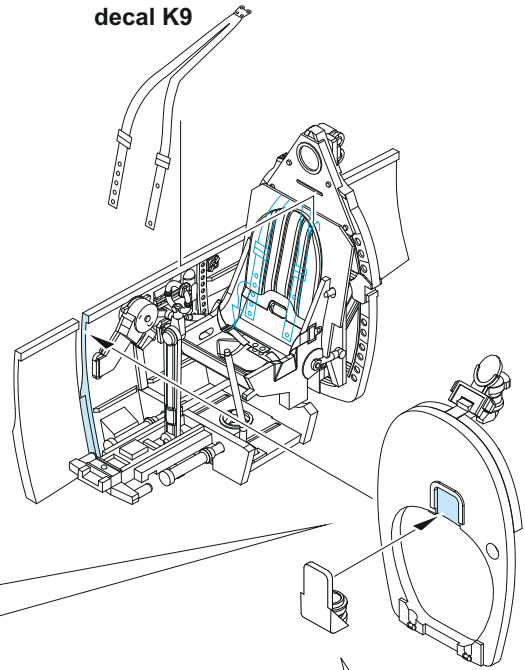
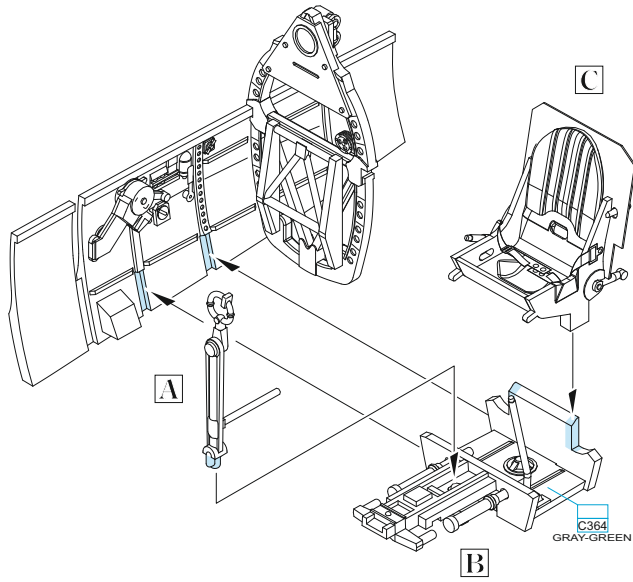

FOR CLOSED CANOPY ONLY

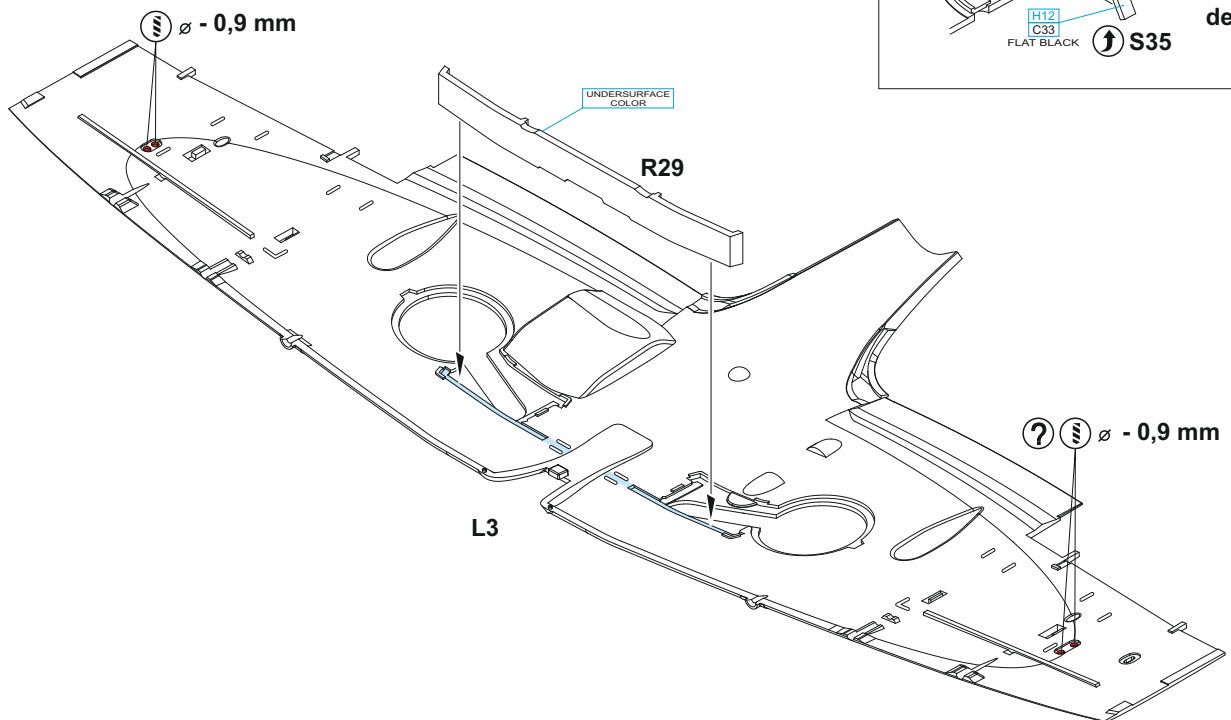
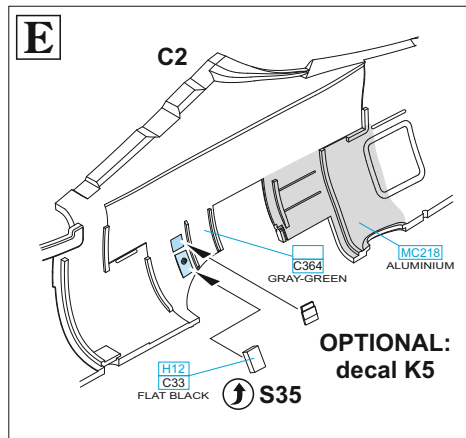
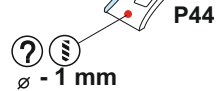
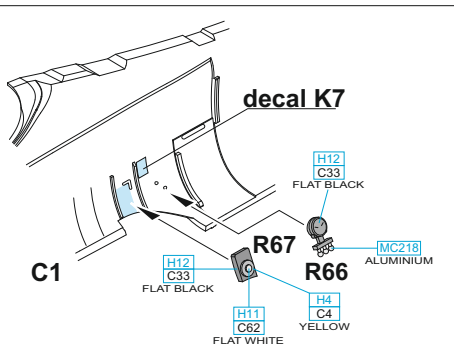
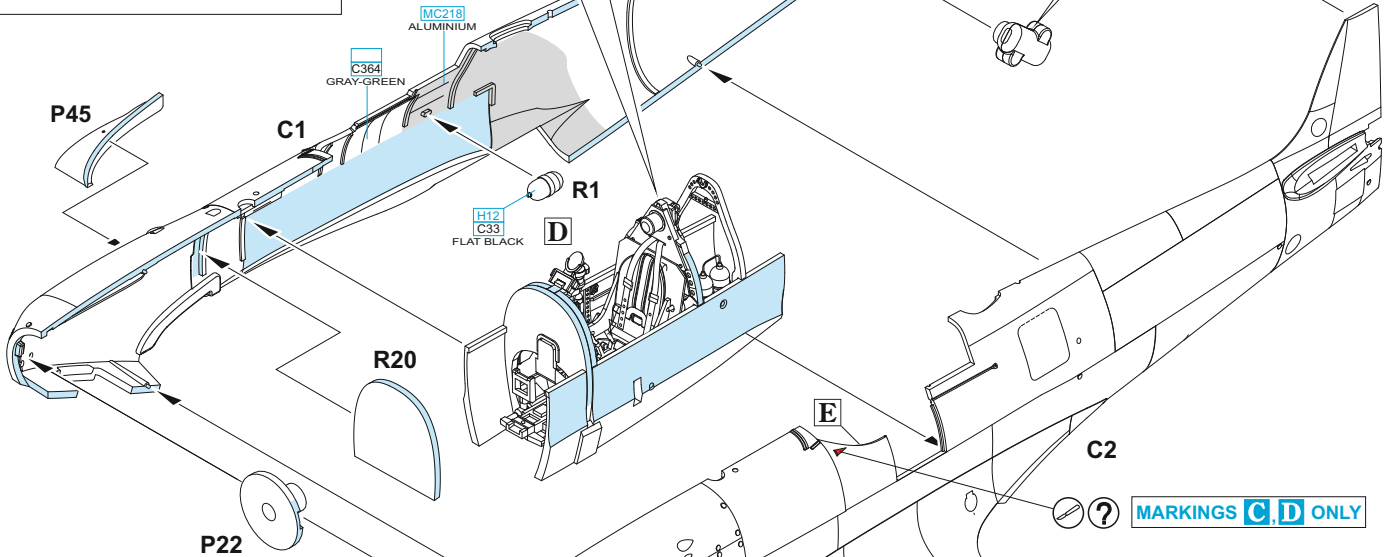
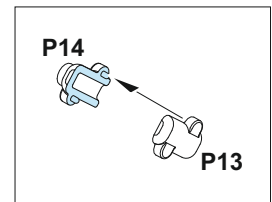
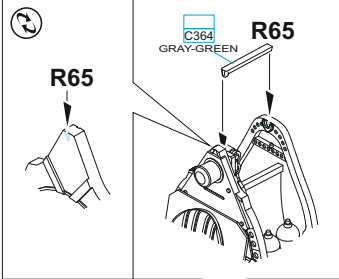
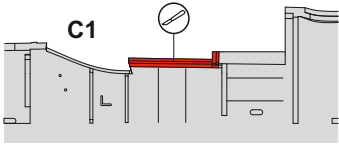
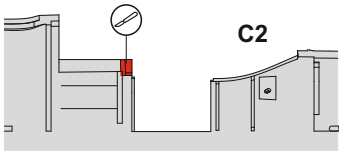

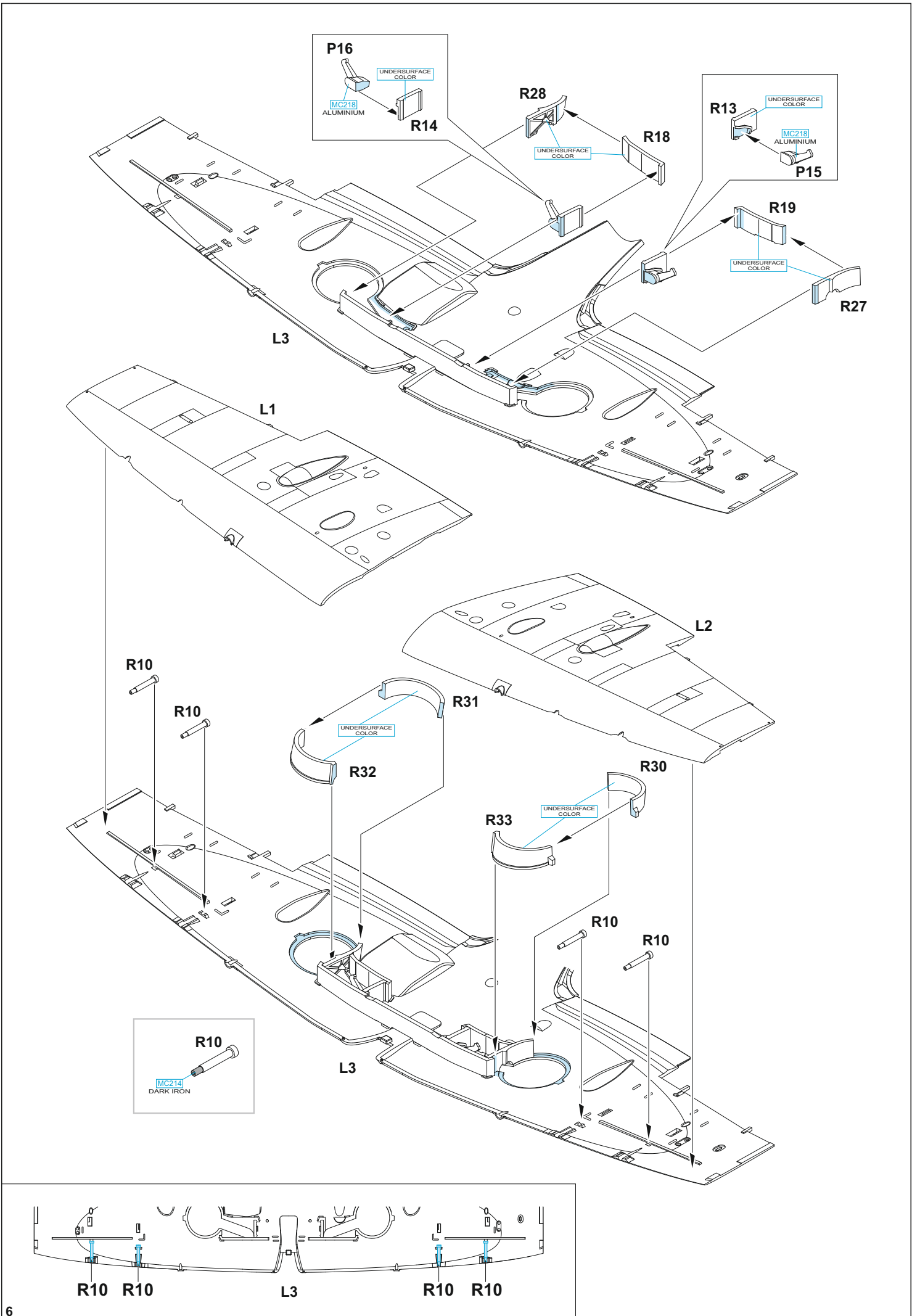

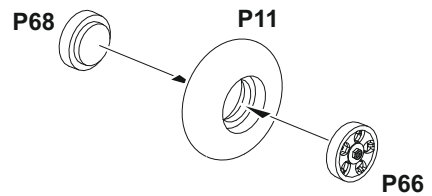
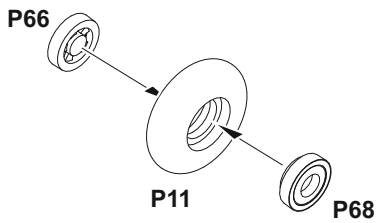
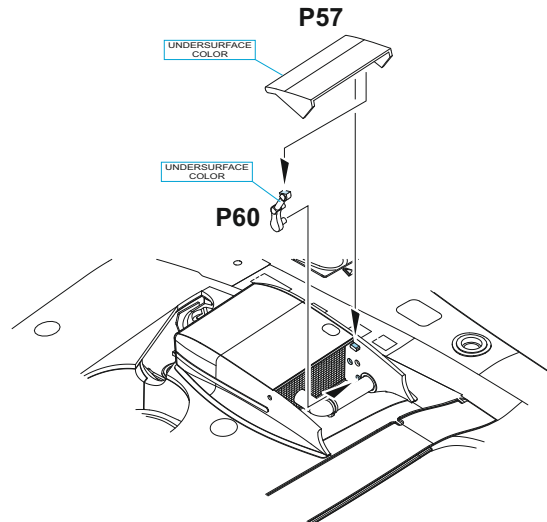
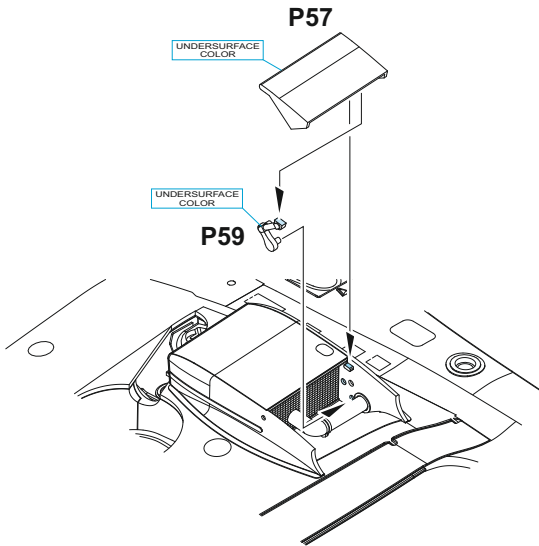
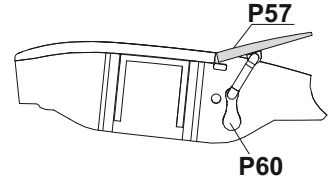
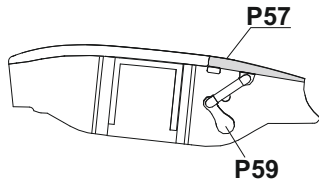
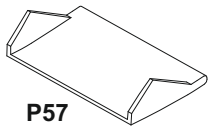
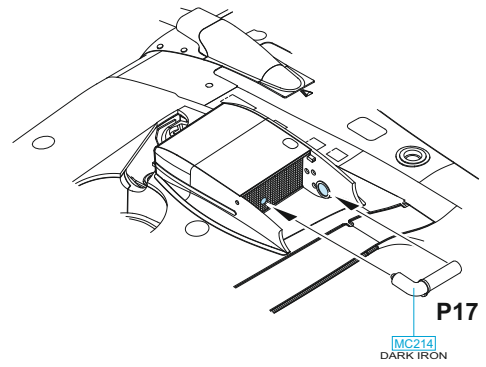
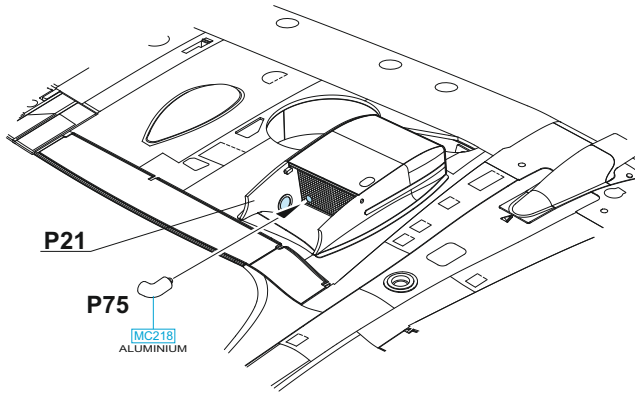

H

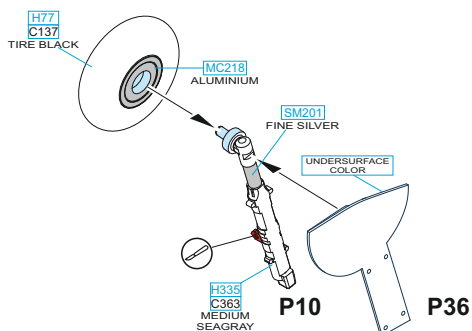

I

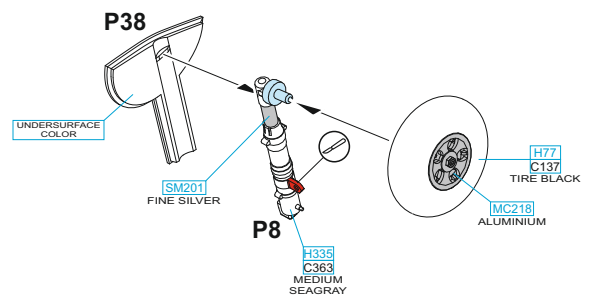

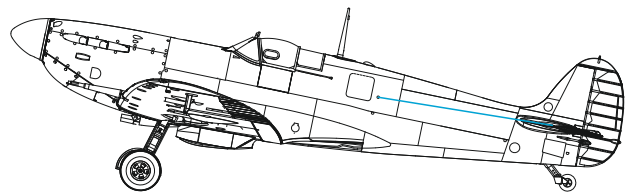
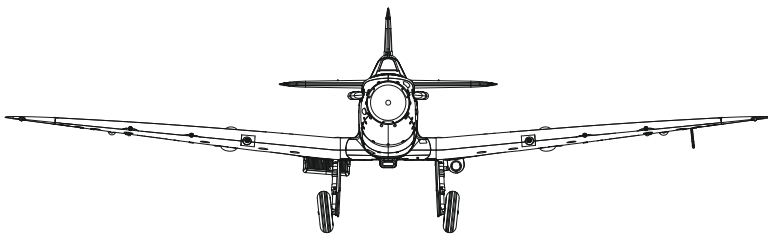
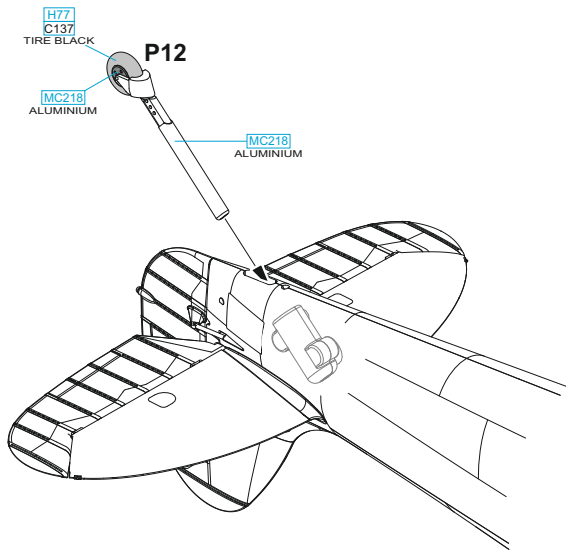
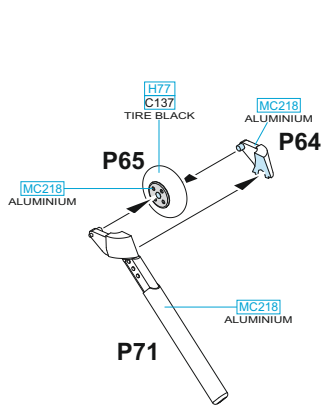
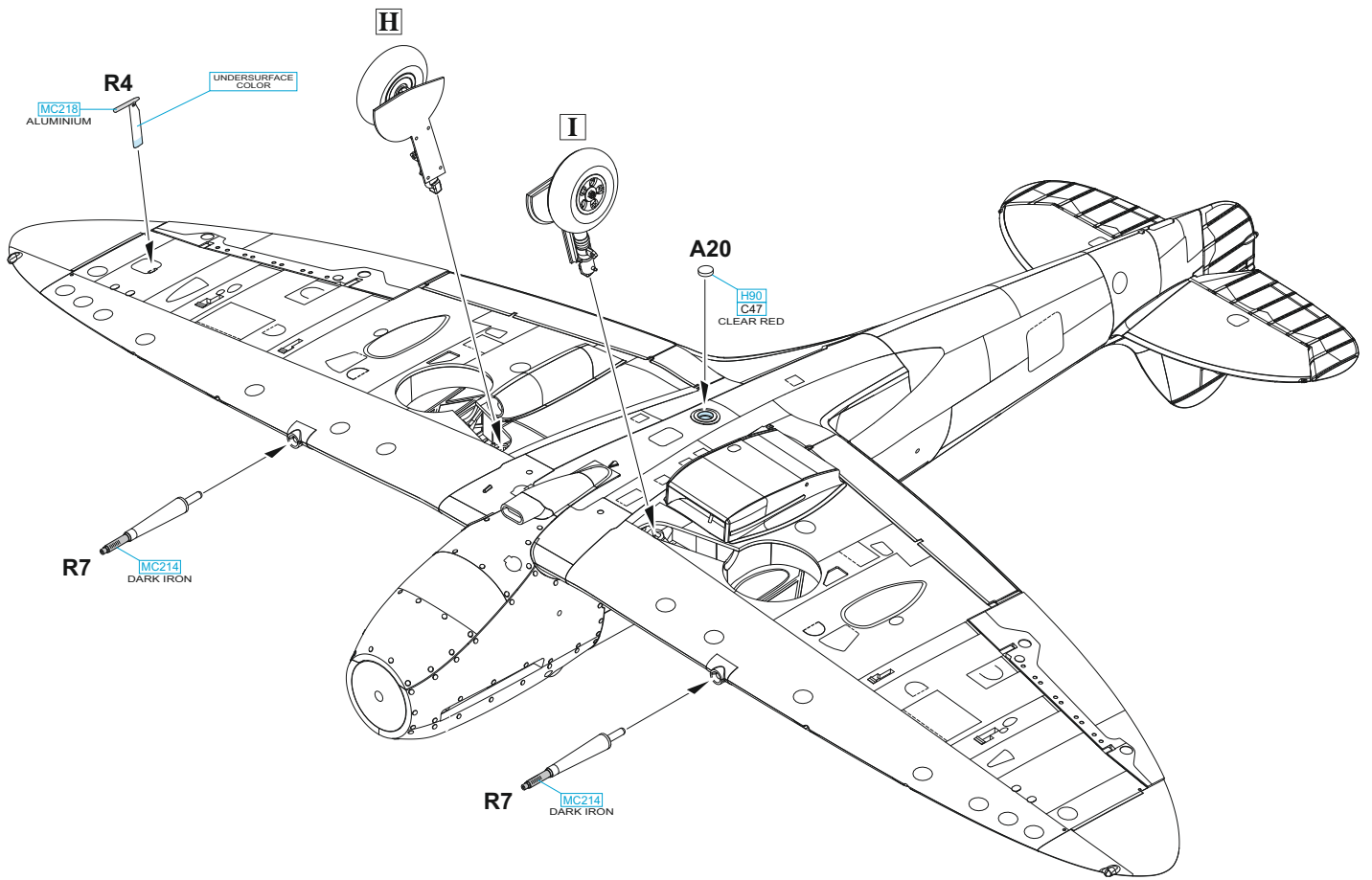

J

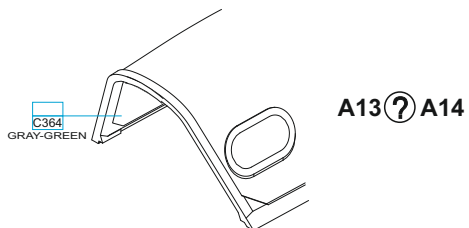

K

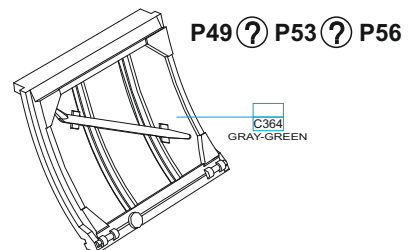

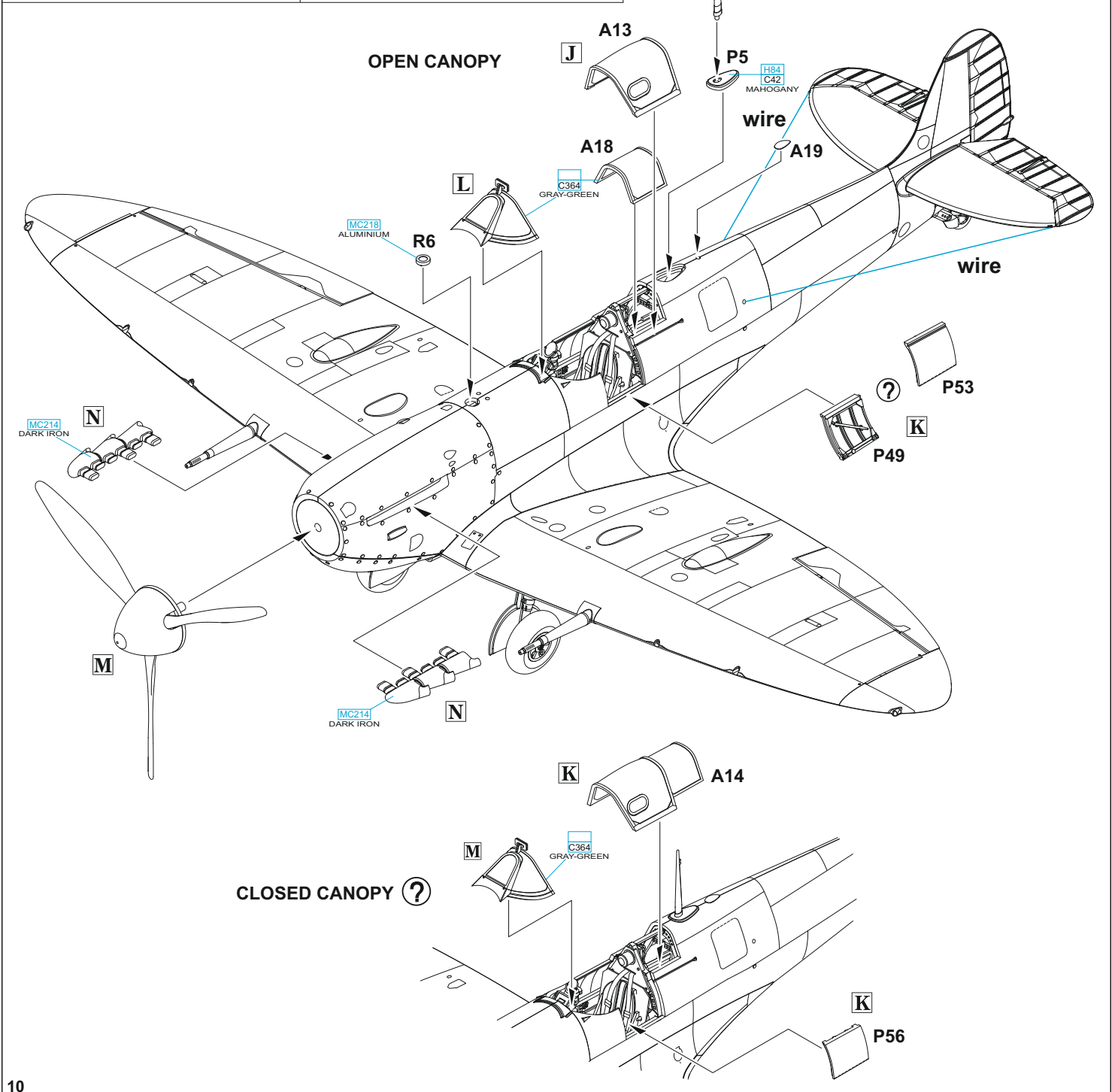
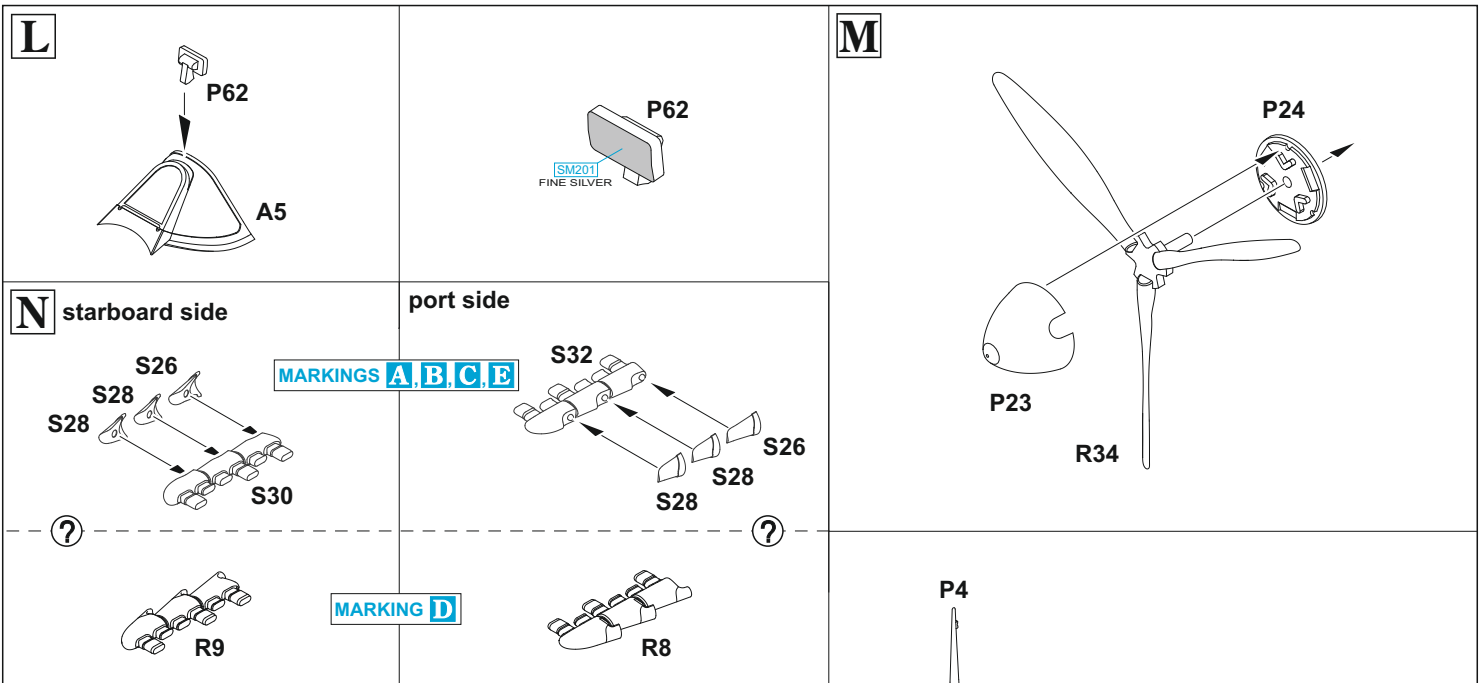

A W3312, S/Ldr James Rankin, CO of No. 92 Squadron, RAF Biggin Hill, Great Britain, June–August 1941

James Rankin joined the RAF in 1935 and after training he joined No. 25 Squadron, then was transferred to the Fleet Air Arm where he flew with No. 825 Naval Air Squadron on HMS Glorious. After serving with the FAA he became an instructor with No. 5 OTU. In early 1941 he was promoted to Squadron Leader and transferred to No. 64 Squadron to gain operational experience. During his short time with this unit, he is credited with shooting down one-third of a Ju 88 and two damaged enemies. In February 1941 he took command of No. 92 East India Squadron, which was in the process of being rearmed with the new Mk.Vb Spitfires. During the summer fighting his score increased rapidly. In June 1941 he was awarded the Distinguished Flying Cross for nine kills and on June 14 he shot down Galland's wingman, Obfw. Robert Menge of III./JG 26 (18 victories). Spitfire W3312, which was Jamie Rankin's personal aircraft, was one of the most successful and brightly colored Spitfires in the RAF. It was decorated with the inscription EAST INDIA SQUADRON on the left side of the tank cover and the pilot's personal emblem, which was a red lion in the crest. Under the cockpit, Rankin had symbols of the kills he had achieved. On the right side, the donation inscription "The Wiltshire Moonraker I" was displayed under the cockpit. Rankin's Spitfire was camouflaged with a standard scheme consisting of shades of Dark Green / Dark Earth / Sky.

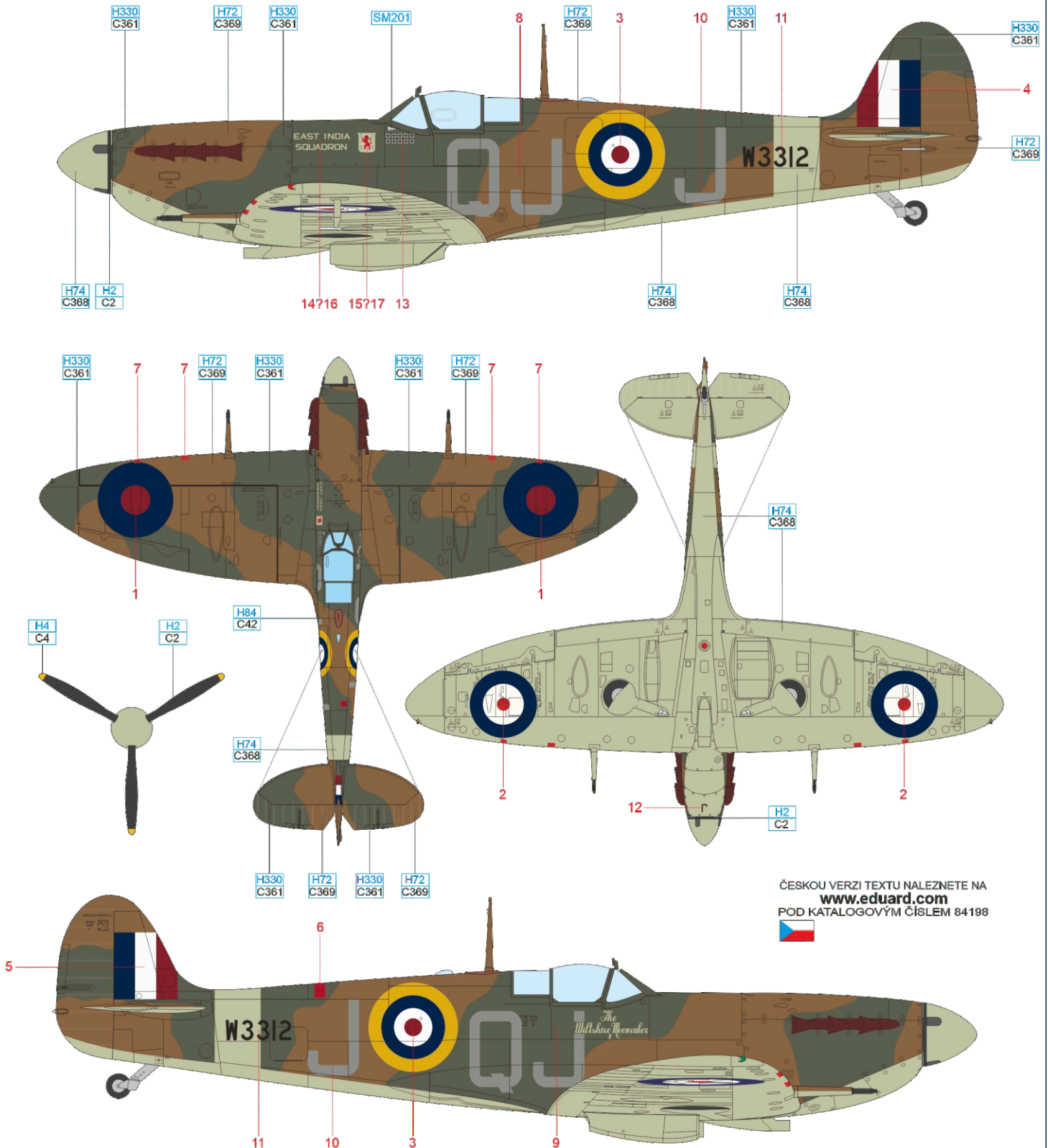

ČESKOU VERZI TEXTU NALEZNETE NA
www.eduard.com
 POD KATALOGOVÝM ČÍSLEM 84198



BLACK	H2 C2	MAHOGANY	H84 C42	YELLOW	H4 C4
SKY	H74 C368	DARK GREEN	H330 C361	DARK EARTH	H72 C369
			SUPER FINE SILVER 2	SM201	

B W3312, W/Cdr James Rankin, CO of Biggin Hill Wing, RAF Biggin Hill, Great Britain, August–December 1941

In September 1941 Rankin became Wing Commander at Biggin Hill and in October received the Distinguished Service Order. In December 1941 Rankin completed his tour of operations and was sent to Fighter Command. He returned to operational flying in April 1942 and led the Biggin Hill Wing again until December 1942. He then served at Central Gunnery School and in August 1943 took command of No. 15 Fighter Wing. During the Normandy landings in June 1944, he was commanding officer of No. 125 Wing. Rankin scored a total of 22 kills against enemy aircraft, including five shared ones (13+1 on Spitfire W3312), three probable and two shared probable kills, 16 damaged and three shared damaged. Almost all of the kills were achieved on Spitfires Mk.Vb. The Spitfire that Rankin flew in the autumn of 1941 as Wing Commander of Biggin Hill already carried the new camouflage scheme effective from August 16. Photographs show the use of a very dark shade of Mixed Grey (probably Extra Dark Sea Grey) in place of the original Dark Earth, the lower surfaces were in the new Medium Sea Grey. Although Rankin, as Wing Commander, could have chosen his initials in place of the squadron code letters, he did not use this option and retained the original code letters QJ-J, newly repainted in the Sky shade.

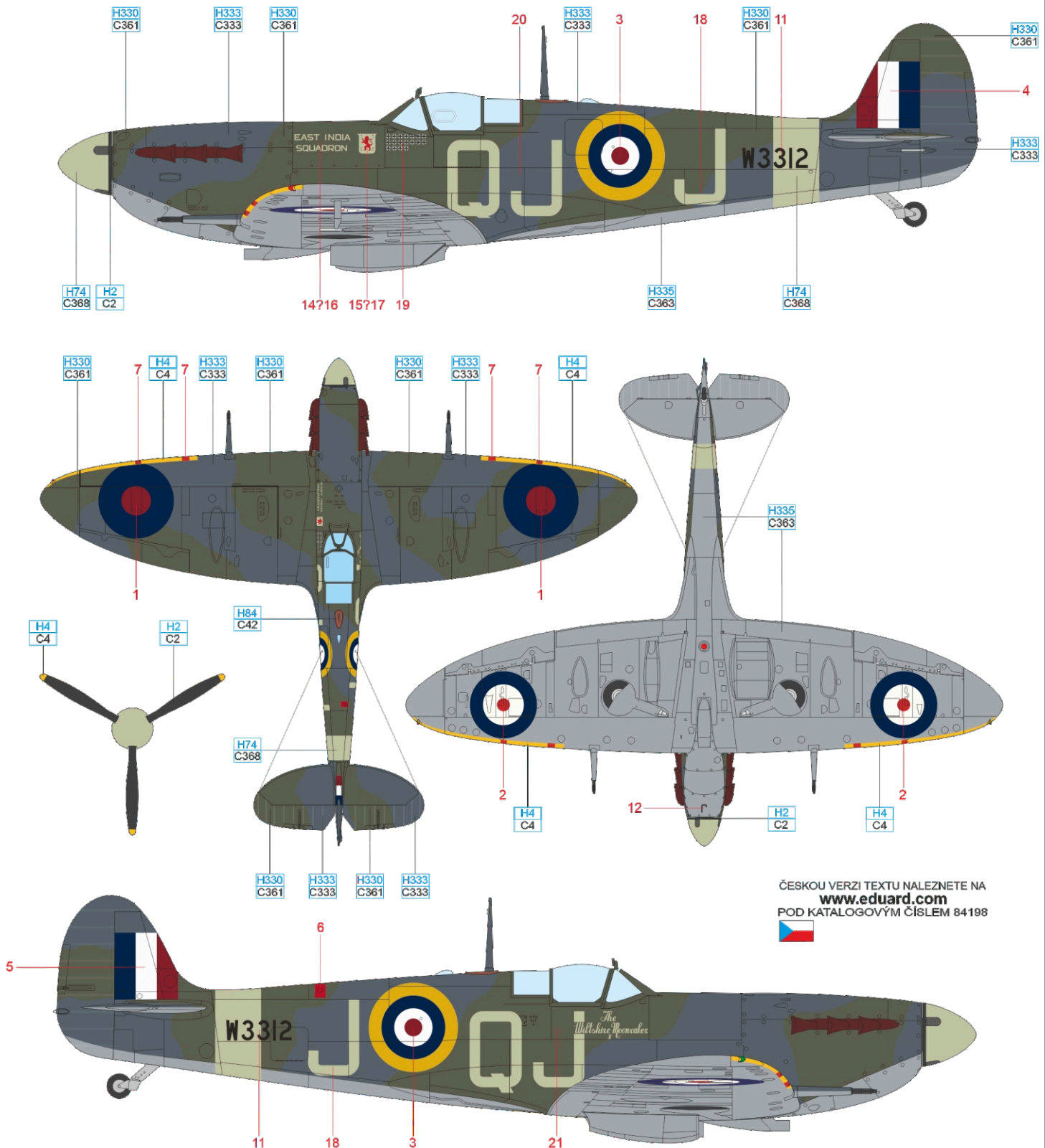

ČESKOU VERZI TEXTU NALEZNETE NA
www.eduard.com
 POD KATALOGOVÝM ČÍSLEM 84198



BLACK	H2 C2	MAHOGANY	H84 C42	YELLOW	H4 C4
SKY	H74 C368	DARK GREEN	H330 C361	EXTR. DARK SEAGRAY	H333 C333
				MEDIUM SEAGRAY	H335 C363

C W3257, F/Lt Eric S. Lock, No. 611 Squadron, RAF Hornchurch, Great Britain, July-August 1941

The most successful pilot of the Battle of Britain, Eric Stanley Lock, sorted for the first time with his Spitfire W3257 on July 14, 1941. He baptized his new aircraft by fire by shooting down a Bf 109F, which was also his very last kill. Barely three weeks later, on August 3, returning from a Rhubarb mission, he attacked a German column near Pas de Calais and has been missing ever since. It's supposed he was shot down by AA fire and crashed into the sea. Neither his Spitfire Mk.V W3257 nor Lock himself have ever been found. At the time of his disappearance his score stood at 26 kills achieved during 25 weeks of the operational deployment in course of one year out of which he spent six months in the hospitals. Spitfire Mk.Vb W3257 was camouflaged in the standard Dark Green/Dark Earth/Sky. Code letters E-FY were painted in Sky which was a standard code letters color of the Hornchurch Wing Spitfires. A serial was overpainted in the camouflage color.

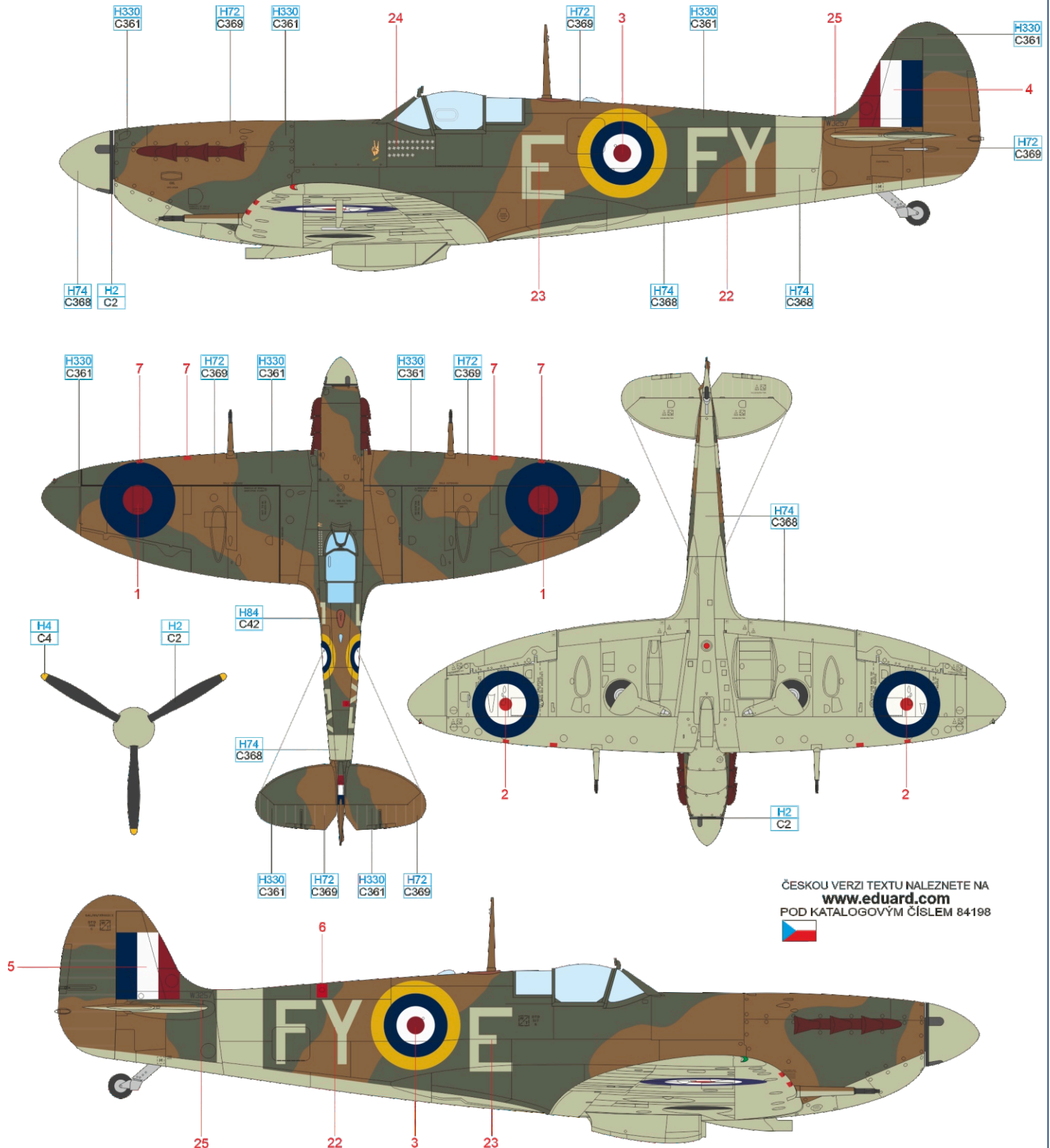

ČESKOU VERZI TEXTU NALEZNETE NA
www.eduard.com
 POD KATALOGOVÝM ČÍSLEM 84198



BLACK	H2 C2	MAHOGANY	H84 C42	YELLOW	H4 C4
SKY	H74 C368	DARK GREEN	H330 C361	DARK EARTH	H72 C369

D W3774, P/O William V. Crawford-Compton, No. 485 Squadron, RAF Kenley, Great Britain, November 1941 – March 1942

One of the RAF's most successful pilots was New Zealander William Vernon Crawford-Compton. He joined the RAF in 1939 as a mechanic, and was subsequently accepted for flight training, which he completed in 1940. In March 1941 he was assigned to the newly formed No. 485 Sqn. and from August 1942 served successfully as commander of B Flight in No. 611 Sqn. In late 1942 he took command of No. 64 Sqn. and led it until the end of March the following year. After a period of staff duties, he became Commander of Hornchurch Fighter Wing in mid-1943 and led it until the end of the year. After his tour of operations, he lectured for three months in the United States on RAF operations. He returned to active service as commander of No. 145 Wing, which he led in offensive operations prior to and after Operation Overlord. After the war he held senior posts in the RAF, retiring as Air Vice-Marshal at the end of 1968. He died in January 1988 at the age of 72. During his wartime career he achieved 22 kills, four probable and he also damaged a further 13 aircraft. The Spitfire W3774 was his first personal aircraft and he achieved four kills flying it. It had a drawing of a burning swastika on the left side under the cockpit and a pan with Hitler's head above it. The left side of the tank cover was decorated with the inscription Auckland 1 "Waiuku". On the right side under the cab was a Samson donation sign. W3774 was given a new livery effective August 16, 1941. Photographs show the use of a very dark shade of Mixed Grey (probably Extra Dark Sea Gre) in place of the original Dark Earth, the Sky band was repainted with a new shade of Medium Sea Grey on the lower surfaces.

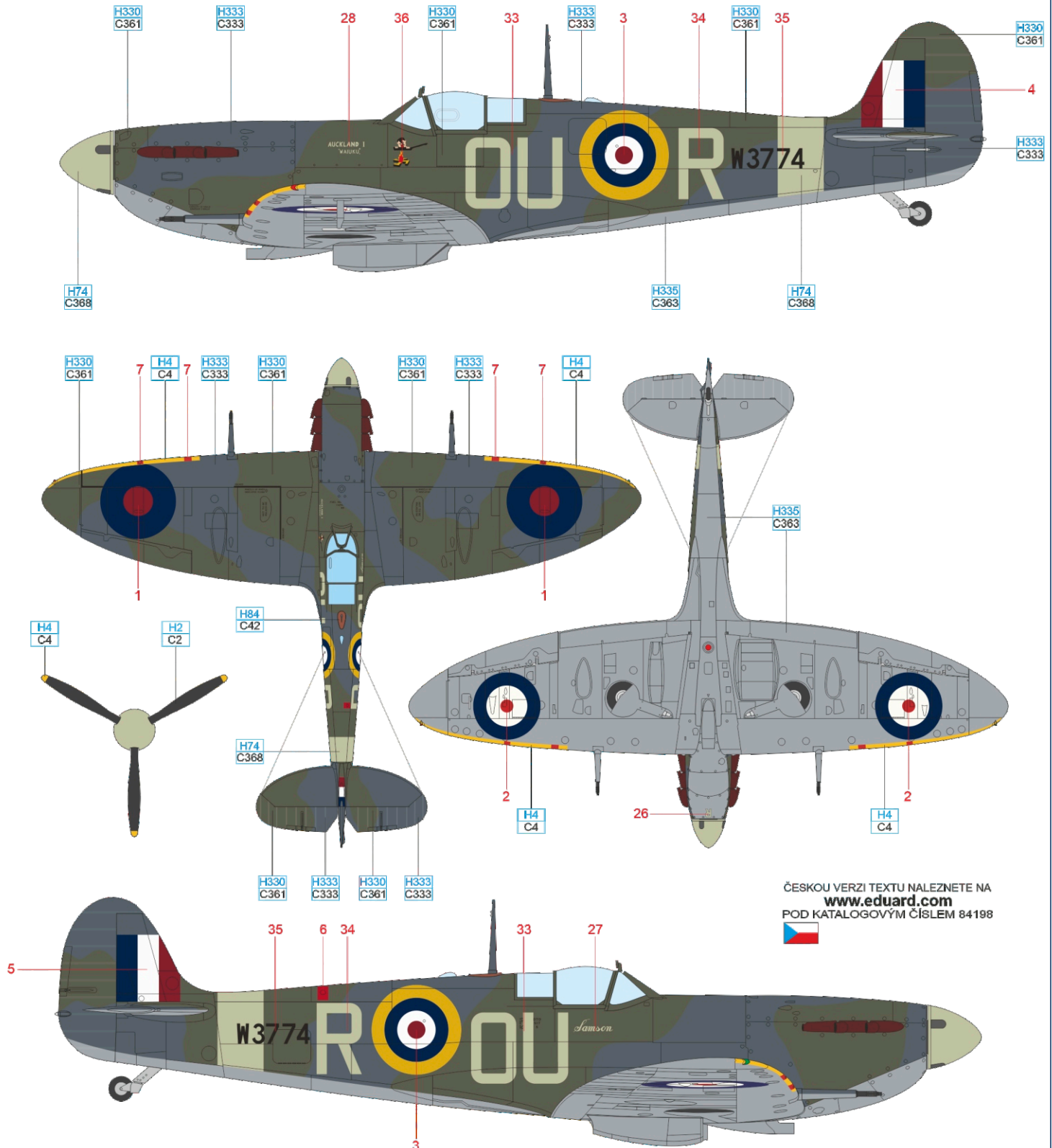

ČESKOU VERZI TEXTU NALEZNETE NA
www.eduard.com
 POD KATALOGOVÝM ČÍSLEM 84198



BLACK	H2 C2	MAHOGANY	H84 C42	YELLOW	H4 C4
SKY	H74 C368	DARK GREEN	H330 C361	EXTR. DARK SEAGRAY	H333 C333
				MEDIUM SEAGRAY	H335 C363

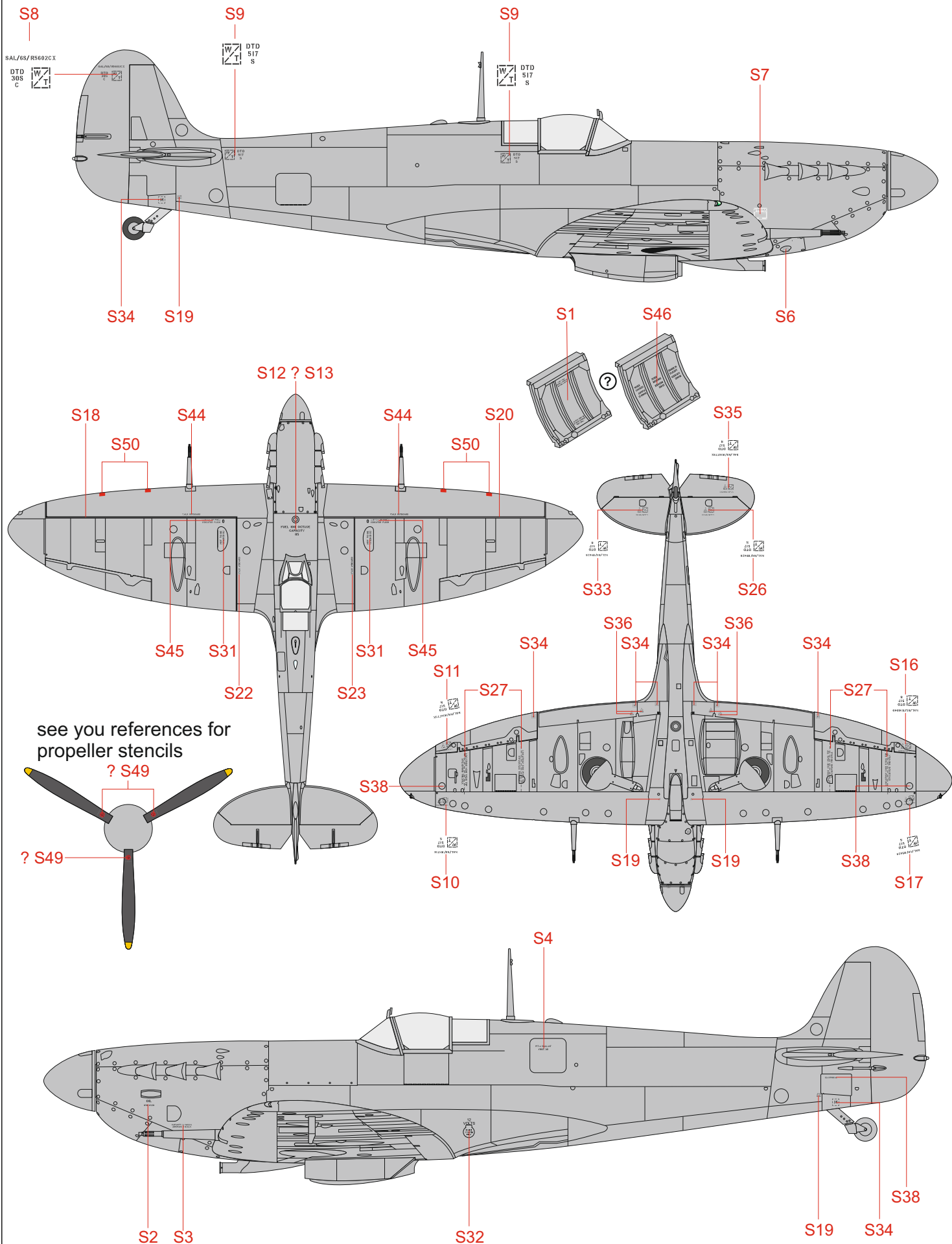

see you references for propeller stencils