



WEEKEND
edition

Fokker's "Eindecker" made history as the first aircraft armed with a synchronized machine gun. This made it a deadly threat to adversaries.

Problems with arming the aircraft with forward-firing machine gun led some designers at the beginning of World War I to several different solutions, such as the use of the pusher propeller concept. The French pilot Roland Garros decided instead to fit the propeller blades of his single-plane Morane-Saulnier N with steel deflector wedges where the bullets passed through the circle of the spinning propeller. While this system was far from ideal, it still presented an unpleasant surprise to the German aviators, and when Garros had to make an emergency landing on German territory and the secret of his shooting through the spinning propeller was revealed, Anthony Fokker was tasked with preparing a similar solution. Legend has it that he constructed a synchronizing device instead and did so in just 48 hours. The system triggered the firing of the machine gun only when the propeller blade was out of the trajectory of the bullets and therefore could not be damaged by the shooting. The mechanical interrupter was actually patented in 1913 by Hans Schneider, the LVG designer, but his design never progressed beyond the stage of a drawing for the patent office. It was only Fokker and his collaborators who managed to put the whole system into practice, improve it and prepare it for practical use, although it is not certain whether they had enough time to do it in just 48 hours... Schneider, however, sued Fokker in court and the dispute dragged on until September 1933.

From E.I to E.III

The first prototype of the K-5 K/MG was armed with a Parabellum machine gun mounted above the engine cowling. After several modifications and a change of weapon to the Spandau LMG 078/15 7.92 mm machine gun, the K-5 Fokker E.I was developed. Anthony Fokker personally demonstrated this armed aircraft to pilots and representatives of the Idflieg (Inspektion der Fliegertruppen; Air Force Inspectorate) at the front to demonstrate its effectiveness and allay the fears of pilots who were apprehensive about firing through the spinning propeller. Success was complete and an order for monoplanes armed with the synchronized machine gun followed. Production took off almost immediately and eventually yielded a total of 415 aircraft, 300 of which were built in the E.III version.

The installation of a 75 kW (100 hp) nine-cylinder Oberursel U I engine in place of the original 60 kW (80 hp) seven-cylinder Oberursel U.0 engine gave birth to the E.II, and the two versions were produced in parallel, depending on the availability of engines. Further modifications, most notably the redesign of the wing, which was given a slightly smaller profile depth (1800 mm instead of 1880 mm), resulted in the main type of the entire Fokker monoplane series, the E.III. The fuel tank

was enlarged to 81 litres, which increased the endurance of the aircraft to 2.5 hours. The shape of the metal aerodynamical covers transitioning the engine cowling to the fuselage was also changed. Instead of a square shape, the fairing was now more aerodynamic. Many E.IIs were converted to the E.III as part of the refit, or were converted during production.

The Fokker scourge

The Fokker monoplanes had very good directional control, but their general maneuverability was limited by the control concept, which used the trailing edge deformation at the wing tips instead of conventional ailerons. Thus, maneuverability and flight characteristics were not their main strengths. It was the synchronization system that fundamentally increased the efficiency of firing when aiming the entire aircraft. Pilots gradually learned to make the most of these advantages. Thanks to the Fokker E.II and E.III, the first real fighter aces like Max Immelmann or Oswald Boelcke were born and German fighters dominated the front from August 1915 until the beginning of 1916. It was on this aircraft that Immelmann developed his famous maneuver, named after him the Immelmann turn. He was not the only one to have success with it in aerial combat.

Fokker's Eindeckers severely disrupted the enemy's ability to conduct aerial reconnaissance or control artillery fire, and this period was referred to by the Allied press as the Fokker Scourge. A certain restriction was the prohibition to fly aircraft equipped with synchronization equipment over the front line, so that the mechanism would not fall into the hands of the enemy in the event of a downed aircraft or an emergency landing due to a malfunction. Nevertheless, trips behind enemy trenches did occur.

Dawn of the Fighters

The effectiveness of the use of the E.II and E.III was limited by the way the aircraft were used. Initially, they were assigned to FFA (Feldflieger Abteilung) field aviation units, which were primarily to conduct reconnaissance and observation flights. The assigned monoplanes were used primarily to protect their own aircraft. However, in early 1916, the KeK (Kampfeinsatz Kommando; Single-Seaters Commando), a unit of single-seat combat aircraft, was formed. Pilots and aircraft were only "loaned" to them by the individual FFA and were not regular units within the Luftstreitkräfte structure. These only became the Fokkerstaffel units, which already had their own aircraft and pilots and became the basis of the future fighter Jagdstaffel units. The Fokkerstaffel bore a designation corresponding to their location and subsequently became standard fighter units called Jagdstaffel, abbreviated Jasta with numeral designation.

ATTENTION



UPOZORNĚNÍ



ACHTUNG



ATTENTION



注意



Carefully read instruction sheet before assembling. When you use glue or paint, do not use near open flame and use in well ventilated room. Keep out of reach of small children. Children must not be allowed to suck any part, or pull vinyl bag over the head.



Před započítím stavby si pečlivě prostudujte stavební návod. Při používání barev a lepidel pracujte v dobře větrané místnosti. Lepidla ani barvy nepoužívejte v blízkosti otevřeného ohně. Model není určen malým dětem, mohlo by dojít k požití drobných dílů.

INSTRUCTION SIGNS * INSTR. SYMBOL * INSTRUKTION SINNBILDEN * SYMBOLES * 記号の説明

OPTIONAL
VOLBABEND
OHNOUTSAND
BROUSITOPEN HOLE
VYVRTAT OTVORSYMETRICAL ASSEMBLY
SYMETRICKÁ MONTÁŽREMOVE
ODŘÍZNOUTREVERSE SIDE
OTOČITAPPLY EDUARD MASK
AND PAINT
POUŽIT EDUARD MASK
NABARVITPLEASE, CHECK THE LATEST VERSION OF THE INSTRUCTIONS ON www.eduard.com

PARTS



DÍLY



TEILE



PIÈCES



部品

A>

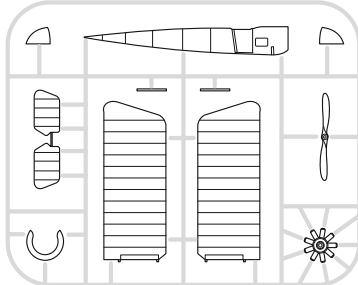

PLASTIC PARTS

B>

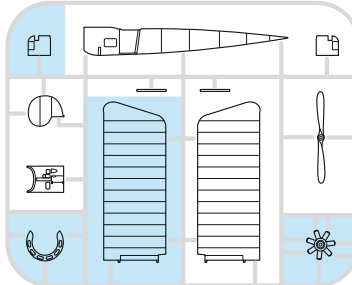

D>



C>

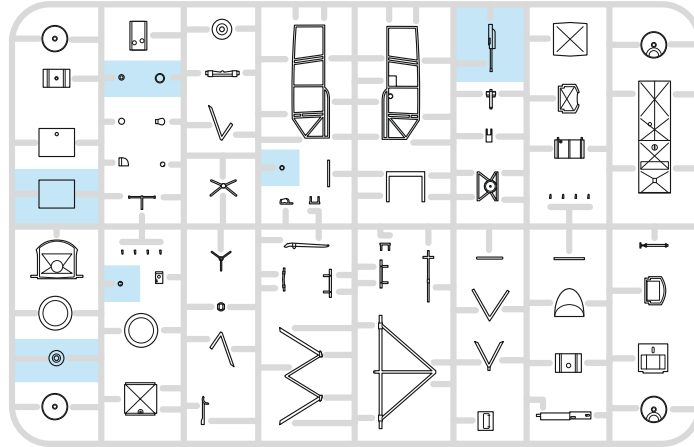

-Parts not for use. -Teile werden nicht verwendet. -Pièces à ne pas utiliser. -Tyto díly nepoužívejte při stavbě. - 使用しない部品

COLOURS



BARVY



FARBEN



PEINTURE



色

GSI Creos (GUNZE)		
AQUEOUS	Mr.COLOR	
H11	C62	FLAT WHITE
H12	C33	FLAT BLACK
H37	C43	WOOD BROWN
H47	C41	RED BROWN
H51	C11	LIGHT GULL GRAY
H70	C60	RLM02 GRAY
H85	C45	SAIL COLOR
	C70	DARK GREEN
	C74	AIR SUPERIORITY BLUE

GSI Creos (GUNZE)		
AQUEOUS	Mr.COLOR	
H303	C303	GREEN
	C129	LIGHT GREEN
	C135	RUSSIAN GREEN
	C364	AIRCRAFT GRAY-GREEN
	C526	BROWN
Mr.METAL COLOR		
	MC214	DARK IRON
	MC218	ALUMINIUM
	MC219	BRASS

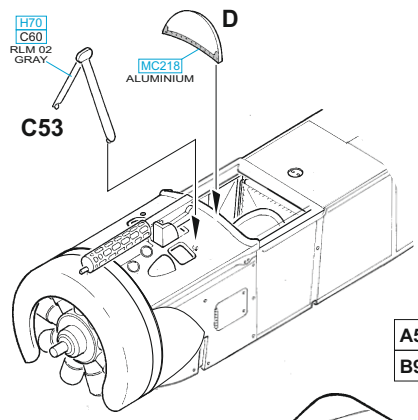
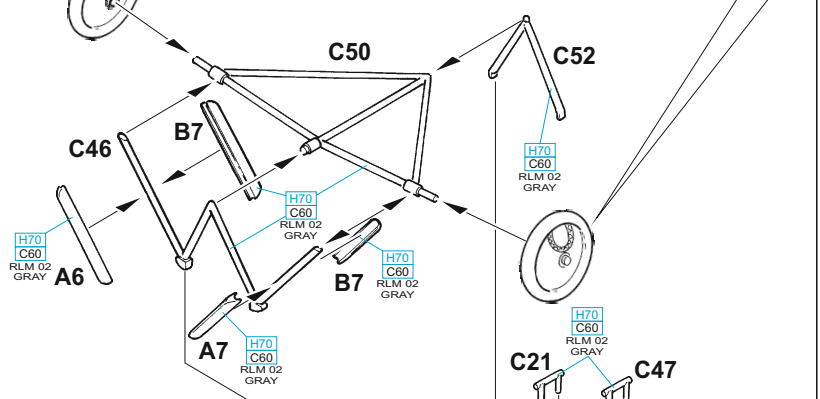
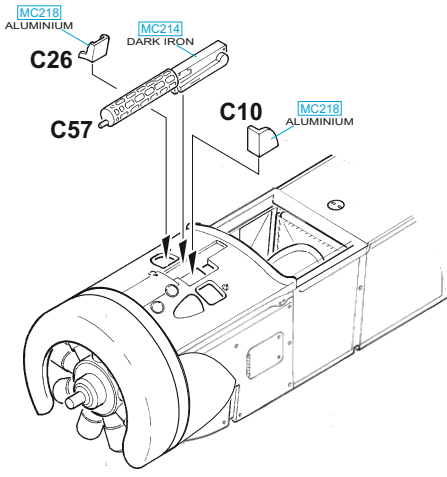
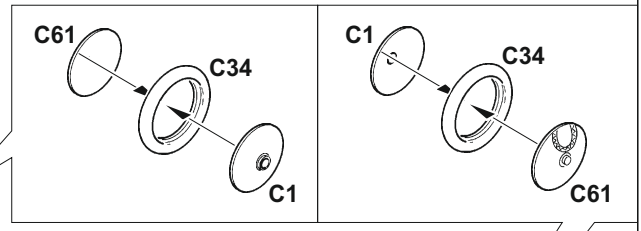
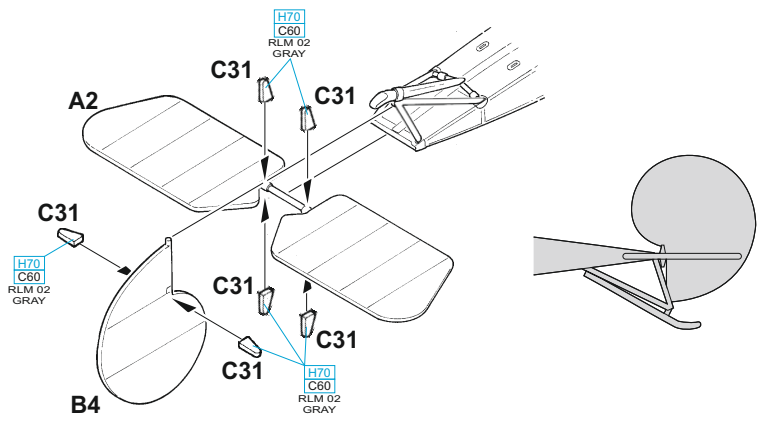
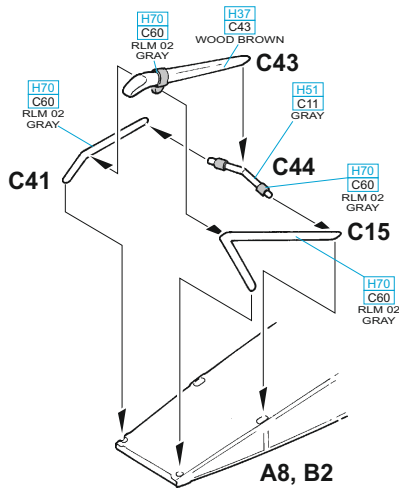

A5 - MARKINGS A, C, D
B9 - MARKING B

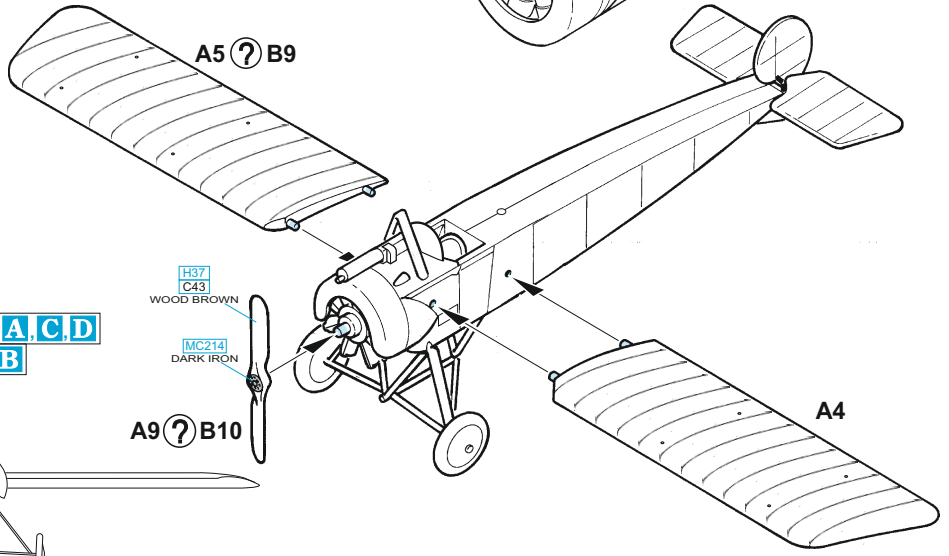

A9 - MARKINGS A, C, D
B10 - MARKING B

A 339/16, Lt. Josef Jacobs, Fokkerstaffel West, June 1916

The advent of Fokker monoplanes armed with synchronized machine guns brought a fundamental change to the course of air warfare from the summer of 1915. The original assignment of these monoplanes to FFA (Feldflieger Abteilung) field aviation units changed in early 1916 when the first German fighter units were formed. The Kampfeinsitzer Kommando (KeK) was a grouping of pilots still belonging to the respective FFA but assigned to fight enemy aircraft. Later, these pilots were allocated to the official fighter units, the Staffeln, in which many future aces grew up. One of them was Josef Carl Peter Jacobs, who spent the first year of his flying career as an observation pilot in FFA 11, only to join Fokkerstaffel West in April 1916. He achieved his first confirmed victory in May when he shot down a two-seat Caudron and possibly an observation balloon. His Eindecker was given a coat of green paint on upper and side surfaces, which was complemented by brown patches, which camouflaged the aircraft not only in the air but also on the ground. By the end of the war, his tally stood at 48 victories. Jasta 12 was formed from the Fokkerstaffel West personnel on October 6, 1916, but Jacobs was transferred to Jasta 22 just a month later.

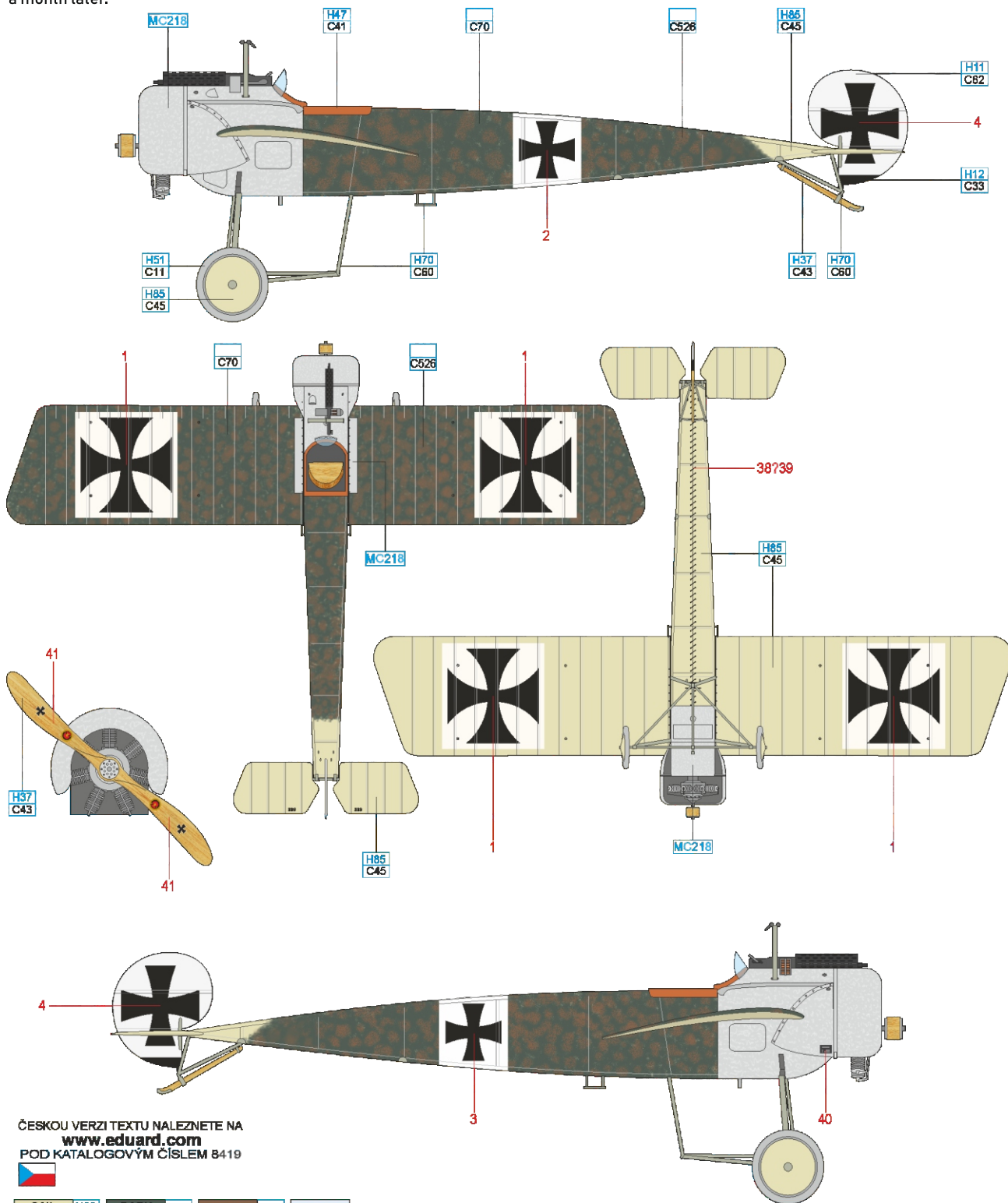

ČESKOU VERZI TEXTU NALEZNETE NA
www.eduard.com
 POD KATALOGOVÝM ČÍSLEM 8419



SAIL COLOR	H85 C45	DARK GREEN	C70	BROWN	C526	ALUMINIUM	MC218
FLAT BLACK	H12 C33	FLAT WHITE	H11 C82	WOOD BROWN	H37 C43	RED BROWN	H47 C41
				RLM 02	H70 C80	LIGHT GULL GRAY	H51 C11

B 105/15, Ernst Udet, KeK Habsheim, 1916

The most successful surviving fighter of World War I was Ernst Udet, who started his flying career with Feldflieger Abteilung 206, from where he moved to FFA 68. There he was given his first Eindecker, but he destroyed it due to an engine malfunction during take-off. He was then assigned an older example of the same type. On March 18, 1916, Udet achieved his first aerial victory. Later that year, FAA 68 was transformed into Kampfeinsitzer Kommando Habsheim and then became Jasta 15 on September 28. Udet's E.III was given paint of unspecified shade of green, which was complemented by an oblique black and white stripe. For this, the black section was later overpainted with a different shade of green. The color scheme and decals offer both variations.

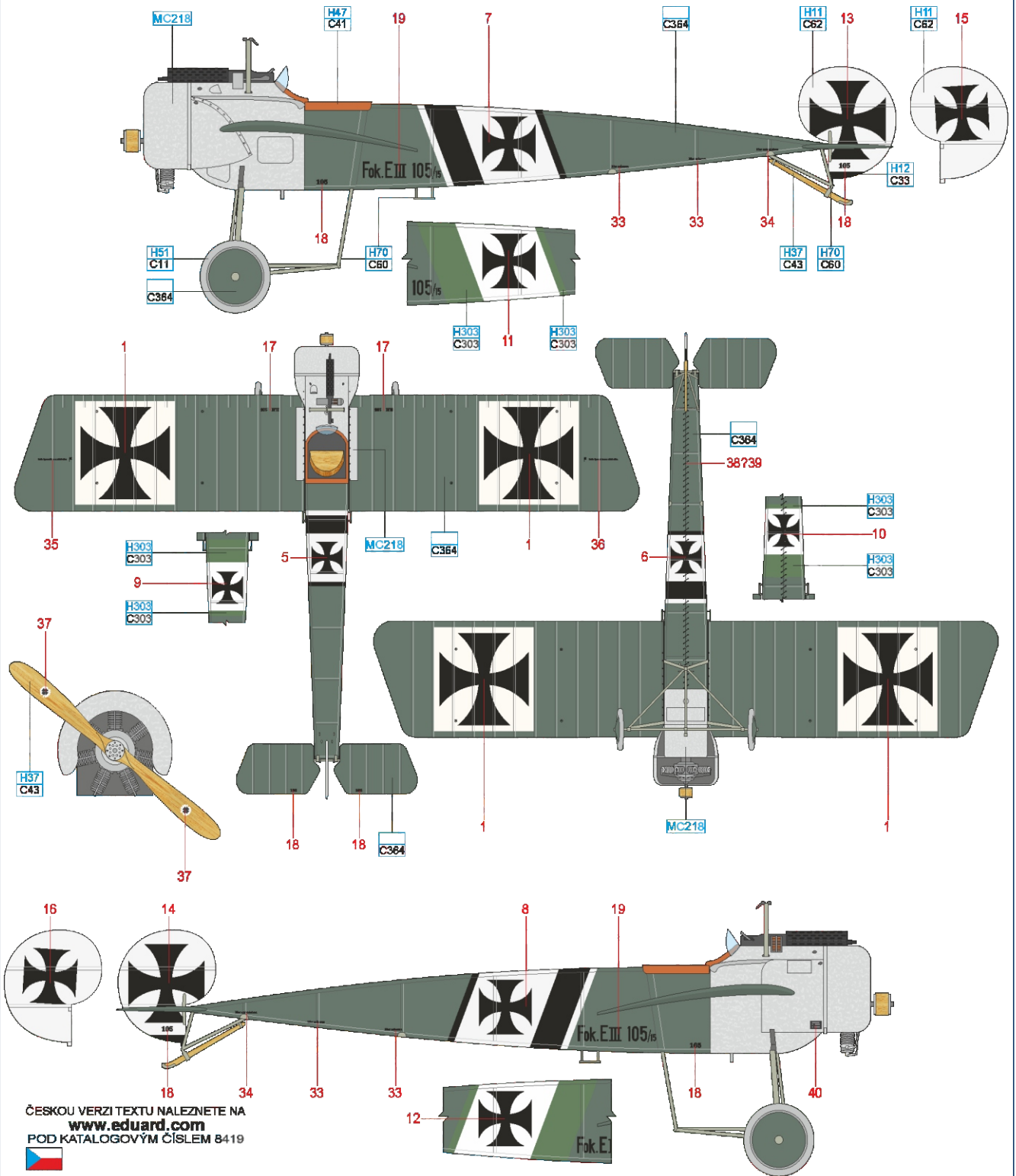

ČESKOU VERZI TEXTU NALEZNETE NA
www.eduard.com
 POD KATALOGOVÝM ČÍSLEM 8419



GREEN	H303 C303	GREEN	C364	ALUMINIUM	MC218
FLAT BLACK	H12 C33	FLAT WHITE	H11 C62	WOOD BROWN	H37 C43
		RED BROWN	H47 C41	RLM 02	H70 C60
				LIGHT GULL GRAY	H51 C11

D Austro-Hungarian Navy, Abwehrflugstation Altura, Austria-Hungary, 1916

Within the Austro-Hungarian Air Force and Navy served Fokker E.IIIs with the designation A.III. Some of them had the Austro-Hungarian Schwarzlose machine gun installed instead of the original German LMG. However, this was not the case with this aircraft. This one was armed with the LMG machine gun, but it was the Navy version with simple gunsight and a slightly different perforation of the barrel housing. The A.III Fokkers were gradually withdrawn to training units, where they served during the last year of the war. This was also the case with this aircraft, which served for training at Altura airfield. There, on February 24, 1918, the Brno native Leodegar Ustyněk fatally crashed during a training flight. When shooting on a target, the engine failed, the aircraft lost speed and crashed from a height of about 50 m. Interestingly, there are two types of crosses used on the aircraft. While on the wings there was an older type, on the fuselage a newer one was used. For the bottom surfaces, historians are inclined towards a light blue color.

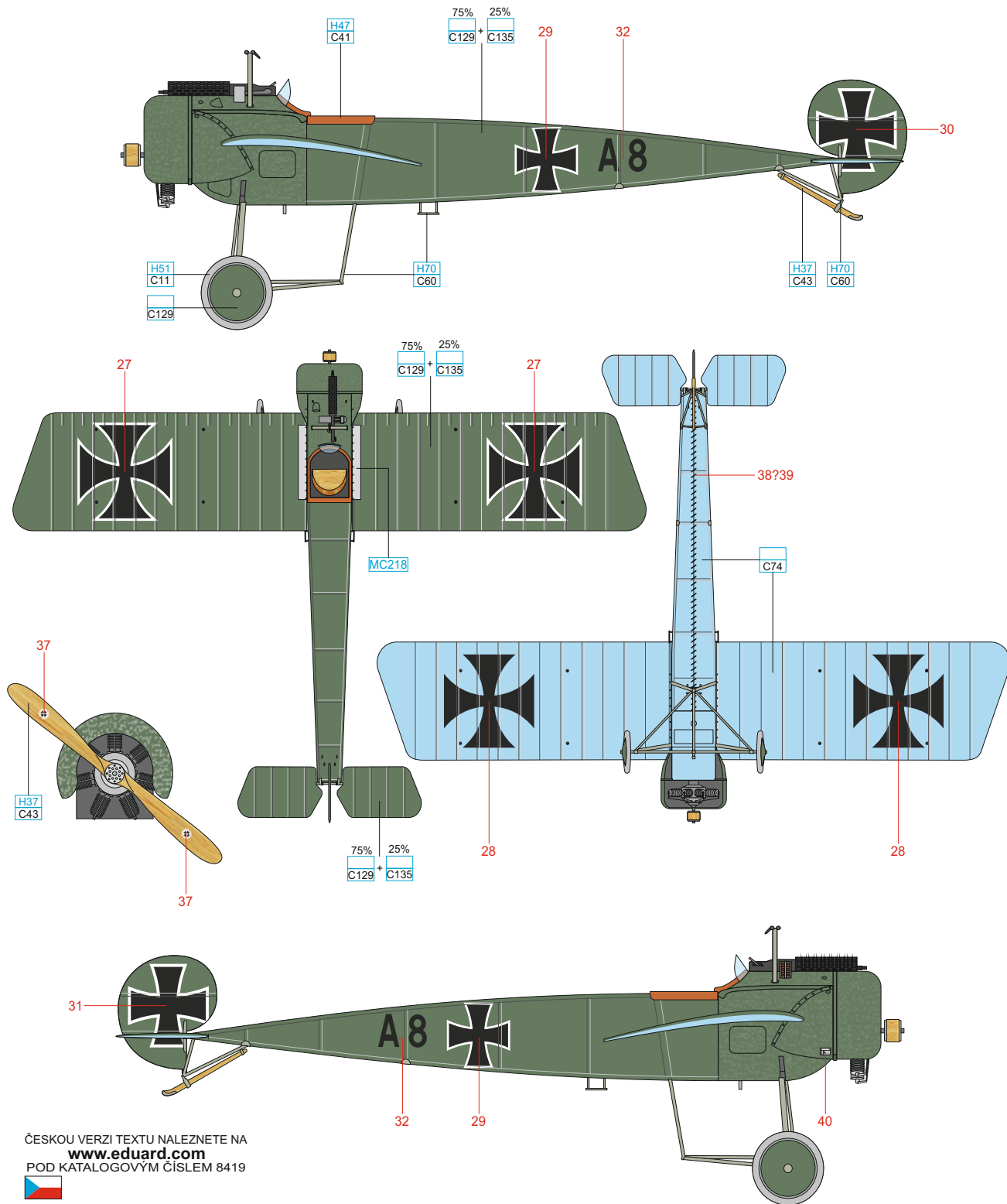

ČESKOU VERZI TEXTU NALEZNETE NA
www.eduard.com
 POD KATALOGOVÝM ČÍSLEM 8419



DARK GREEN	C129	GREEN	C135	AIRSUP. BLUE	C74	ALUMINIUM	MC218
WOOD BROWN	H37 C43	RED BROWN	H47 C41	RLM 02	H70 C60	LIGHT GULL GRAY	H51 C11

The second most successful fighter of the German Navy started his flying career as an observer in the Freiwilliges Marine-Fliegerkorps. In December 1914, he was transferred to Marine-Feldflieger-Abteilung I. In the first half of April 1916, the unit took over this E.III number LF196 and it most likely became the aircraft of the then newly trained fighter pilot Gotthard Sachsenberg. The aircraft was left in gradually accumulated oil stains and other dirt and, according to photographs, was put "on its nose" by its pilot during an emergency landing near Ostende. We do not know when this happened, but the aircraft was subsequently taken to the airfield in a dismantled state and continued to fly until the end of November, when most E.IIIs were retired in favor of new Halberstadts.

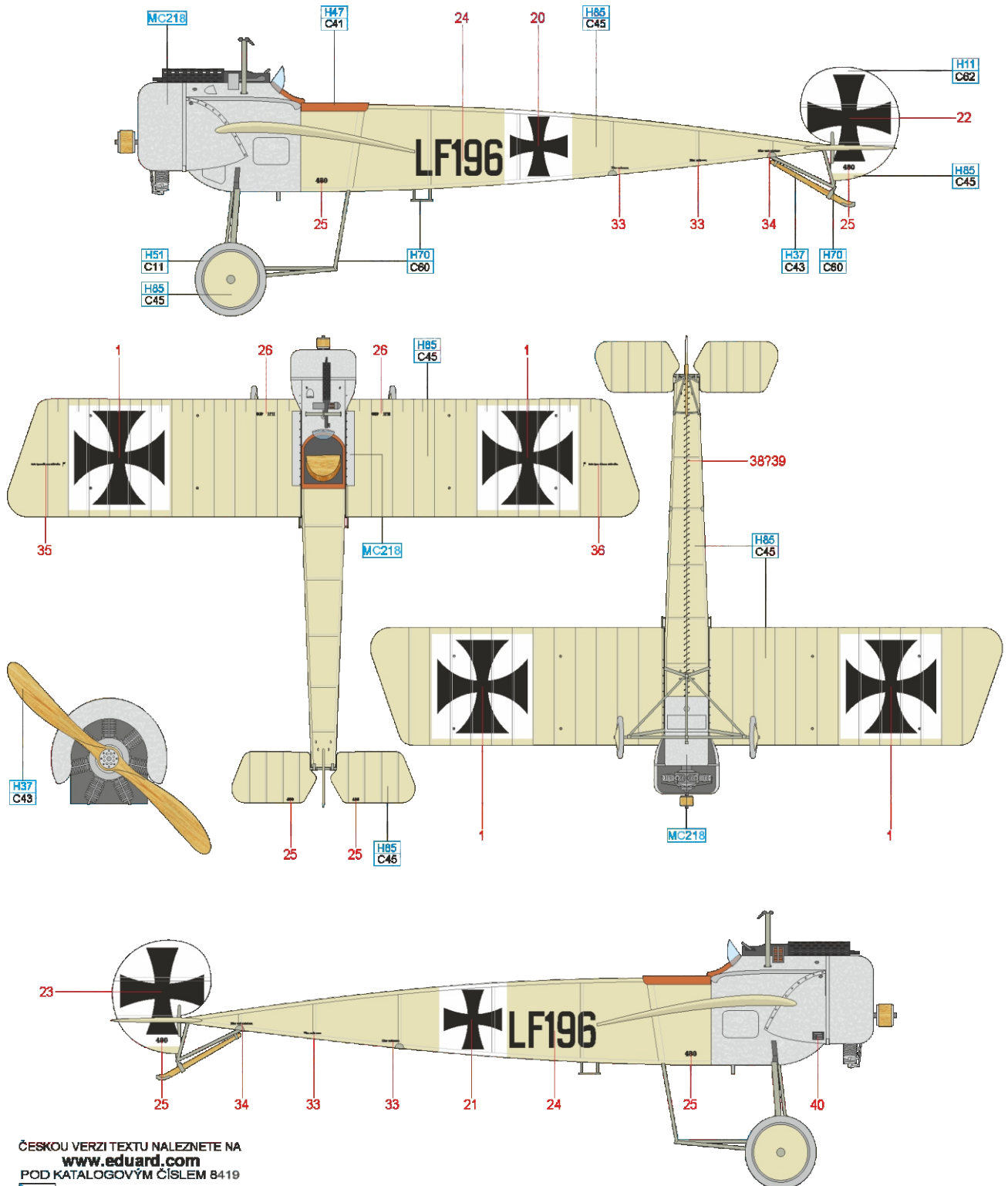

ČESKOU VERZI TEXTU NALEZNETE NA
www.eduard.com
 POD KATALOGOVÝM ČÍSLEM 8419



SAIL COLOR	H85 C45	ALUMINIUM	MC218						
FLAT WHITE	H11 C82	WOOD BROWN	H37 C43	RED BROWN	H47 C41	RLM 02	H70 C80	LIGHT GULL GRAY	H51 C11