

F4F-4 Wildcat late

eduard

1/48 Scale Plastic Model Kit

WEEKEND
edition



item # 84204

At the outbreak of the War in the Pacific, the Wildcat was the main fighter aircraft on the carrier decks of US Navy ships. And even the introduction of more advanced Hellcat and Corsair fighters was not the end of story for their predecessor. In fact, Wildcat became a star of the escort carrier fleet and served until the end of the war.

In the early 1930's Grumman company became a major supplier of fighter aircraft to the US Navy with the FF biplane and its successors, the F2F and F3F. By 1935, however, the biplanes were reaching their limits and with the XF4F-1 prototype (factory designation G-19) Grumman failed against the cantilever monoplane Brewster F2A-1 Buffalo in the US Navy's competition for a new fighter. The XF4F-1 prototype was retained as a backup, but at Grumman they realized biplanes had become obsolete, so they redesigned it as an all-metal mid-wing monoplane, designated the XF4F-2 (G-18).

The fuselage was adopted with only minor changes, the wing employed the newly-developed NACA 230-series airfoil. Powered was delivered by a 1,000 hp (750 kW) Pratt & Whitney R-1830-66 Twin Wasp engine with a single-stage single-speed supercharger. The 110 gal (415 l) fuel tank was located beneath the cockpit with a 20 gal (75 l) reserve tank behind the pilot's seat. Armament consisted of two .30 (7.62 mm) machine guns in the fuselage and two .50 (12.7 mm) machine guns in the wing. There were also provisions for two 100lb (45kg) bombs under the wing. Undercarriage was structurally complex design adopted from previous types, which the pilot retracted manually into the fuselage using a crank.

The maiden flight of the XF4F-2 occurred on September 2, 1937, and in April 1938 comparative trials were conducted with the XF2A-1 Buffalo and with the Seversky XFN-1. Although the Wildcat prototype was the fastest, it still did not meet the Navy's requirement of 300 mph (482 km/h). Finally, it was Brewster who received an order to deliver 54 units of the F2A-1 Buffalo, as this handled better, had hydraulically operated landing gear and was powered by less complicated Cyclone engine. Grumman did not give up, however, and work on an improved version of the XF4F-3 (G-36) began.

On the third try

The fuselage was lengthened to 28ft (8.53m) but otherwise was almost unchanged. The wingspan was also increased from 34 ft (10.36 m) to 38 ft (11.58 m) with squared-off tips. A P&W XR-1830-76 engine with two-stage, two-speed supercharger rated at 1,200 hp (890 kW) was selected. The prototype made its maiden flight on February 12, 1939, and reached a speed of 333,5 mph (537 km/h). As deliveries of the Buffaloes were delayed, the Navy decided to order 54 Grumman, which were named Wildcat on August 8, 1939. The first of these was delivered in February 1940. Production F4F-3s had .30 fuselage machine guns removed and four .50 guns were installed in the wing. The F4F-3 wing did not yet have a folding mechanism, this was not introduced until the F4F-4 version.

In the British service

Even before the US Navy ordered the aircraft, France rushed in, ordering 81 aircraft with the export designation G-36A. These

were powered by the Wright R-1820-G205A-2 Cyclone engine fitted out with a single-stage, two-speed supercharger, developing up to 1,000 (850 kW). The armament consisted of six 7.5 mm Darné machine guns. However, these aircraft never made it to the customer. After the fall of France, they were rebuilt to British specification (the armament changed to four .50 machine guns) and were used by Fleet Air Arm. They served under the name Martlet (changed to Wildcat in January 1944). In all, 1,200 Wildcats of various versions were delivered to the FAA.

Pacific Lumberjack

The Wildcat was the main carrier-borne fighter of the US Navy and USMC at the time of the attack on Pearl Harbor and as such had to face a new and dangerous adversary, the Japanese Zero. Although the Wildcat lagged it in terms of performance and maneuverability, its rugged design, strong armor protection and self-sealing fuel tanks made it tough opponent. In addition, their pilots were also helped by the defensive tactics developed by Lt. Cmdr. John S. "Jimmy" Thach and named the Thach Weave. During the fighting for Guadalcanal, Wildcat pilots also used the "hit and run" high altitude ambush tactics with success. In 1943 new American fighters Grumman F6F-3 Hellcat and Vought F4U-1 Corsair were introduced and Grumman stopped the production of the Wildcat. A total of 7,860 Wildcats and Martlets of all versions were produced.

This kit: F4F-4 Wildcat late

As experience has shown, the armament of four .50 (12.7 mm) machine guns was insufficient for fighting multi-engine bombers. Thus, the British Admiralty made a request for increase in weight of fire, as did a request to add a folding wing. The resulting F4F-4 received a pair of extra .50 machine guns, however, Grumman was faced with an additional weight of the aircraft, which already was lacking power. As they sought a means to limit the weight increase, the ammunition was reduced. Instead of the 450 rounds per barrel of the F4F-3, the F4F-4 had only 250 rounds for each of its six barrels, which cut the firing time from 34 to 20 seconds.

The "Sto-Wing" system, developed by Leroy Grumman, was used for folding wing, in which the outer part of the wing was folded to the rear while being rotated to a near-vertical position. This allowed more of the wing to be folded than would be the case with a vertical -folding wing, limited by the height of the hangar overhead aboard an aircraft carrier.

The F4F-4s were received with reservations by pilots. Increased weight made them less agile and the rate of climb was noticeably reduced. The early production aircraft retained the lifeboat stowage in the fuselage ridge behind the cockpit, with the box only opening to the right.



Carefully read instruction sheet before assembling. When you use glue or paint, do not use near open flame and use in well ventilated room. Keep out of reach of small children. Children must not be allowed to suck any part, or pull vinyl bag over the head.



Před započítím stavby si pečlivě prostudujte stavební návod. Při používání barev a lepidel pracujte v dobře větrané místnosti. Lepidla ani barvy nepoužívejte v blízkosti otevřeného ohně. Model není určen malým dětem, mohlo by dojít k požití drobných dílů.

INSTRUCTION SIGNS * INSTR. SYMBOLS * INSTRUKTION SINNBILDEN * SYMBOLES * 記号の説明

- 
 OPTIONAL
VOLBA
- 
 BEND
OHNOUT
- 
 SAND
BROUSIT
- 
 OPEN HOLE
VYVRTAT OTVOR
- 
 SYMETRICAL ASSEMBLY
SYMETRICKÁ MONTÁŽ
- 
 REMOVE
ODRÍZNOUT
- 
 REVERSE SIDE
OTOČIT
- 
 APPLY EDUARD MASK
AND PAINT
POUŽIT EDUARD MASK
NABARVIT

PLEASE CHECK THE LATEST VERSION OF THE INSTRUCTIONS ON www.eduard.com

PARTS * DÍLY * TEILE * PIĘCES * 部品

PLASTIC PARTS

A>

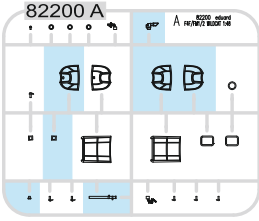

C>

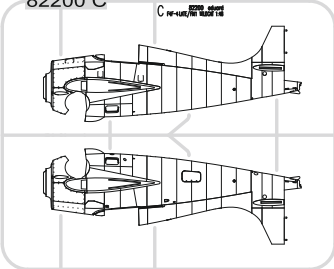

H>

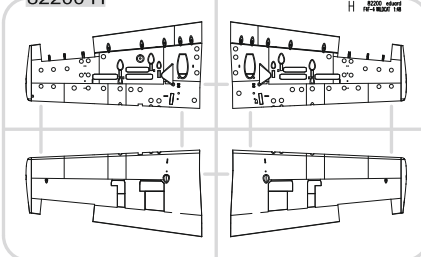

L>

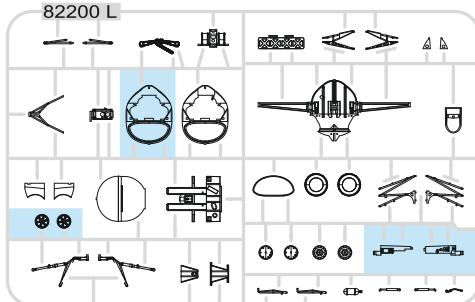

M>

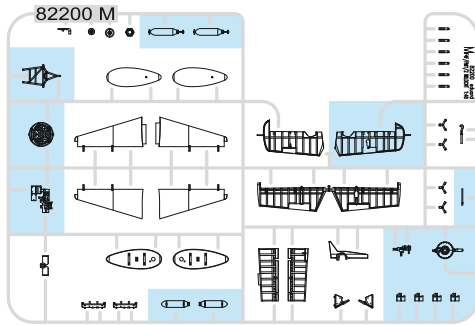

N>

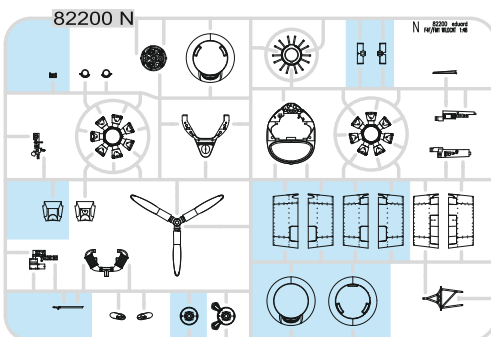

-Parts not for use. -Teile werden nicht verwendet. -Pièces à ne pas utiliser. -Tyto díly nepoužívejte při stavbě. - 使用しない部品

COLOURS * BARVY * FARBEN * PEINTURE * 色

GSI Creos (GUNZE)		
AQUEOUS	Mr.COLOR	
H1	C1	WHITE
H2	C2	BLACK
H6	C6	GREEN
H8	C8	SILVER
H12	C33	FLAT BLACK
H47	C41	RED BROWN
H52	C12	OLIVE DRAB
H54	C365	NAVY BLUE
H56	C366	INTERMEDIATE BLUE
H58	C351	INTERIOR GREEN
H77	C137	TIRE BLACK
H90	C47	CLEAR RED
H92	C49	CLEAR ORANGE
H93	C50	CLEAR BLUE

GSI Creos (GUNZE)		
AQUEOUS	Mr.COLOR	
H94	C138	CLEAR GREEN
H306	C306	MEDIUM GRAY
H316	C316	WHITE
H317	C317	GRAY
H325	C325	GRAY
H327	C327	RED
H329	C329	YELLOW
	C367	BLUE GRAY
Mr.METAL COLOR		
	MC214	DARK IRON
	MC218	ALUMINIUM
	MC219	BRASS
Mr.COLOR SUPER METALLIC		
	SM201	SUPER FINE SILVER

1 = 90% + 10%
 H12 H12
 C351 C33
 INT.GREEN FLAT BLACK

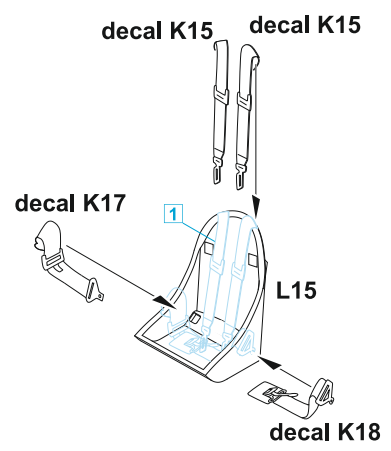
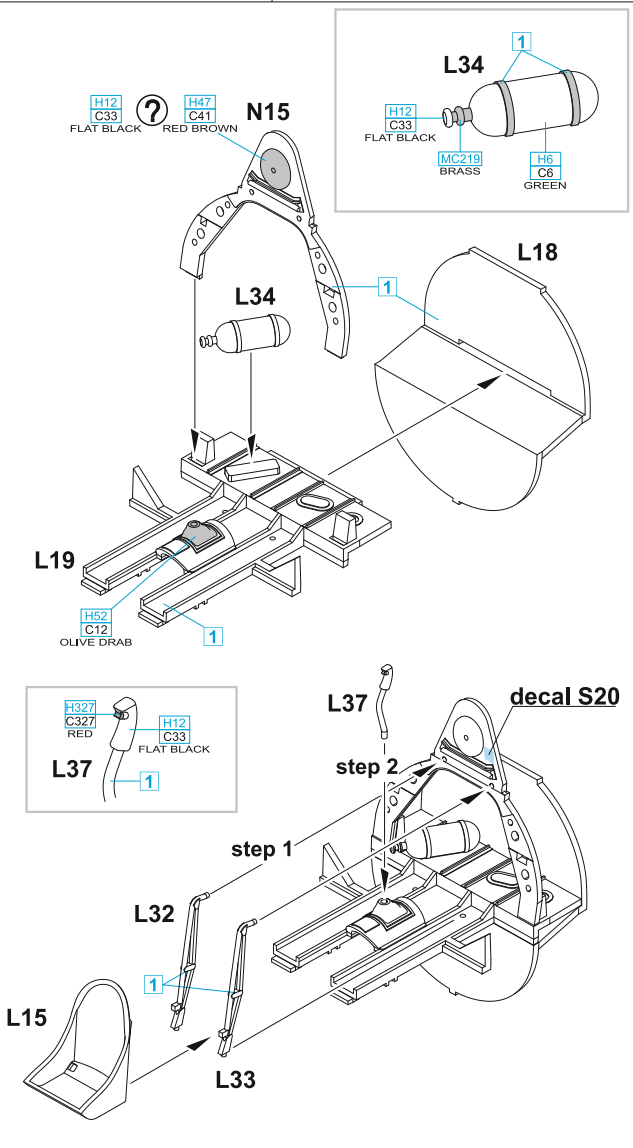

A

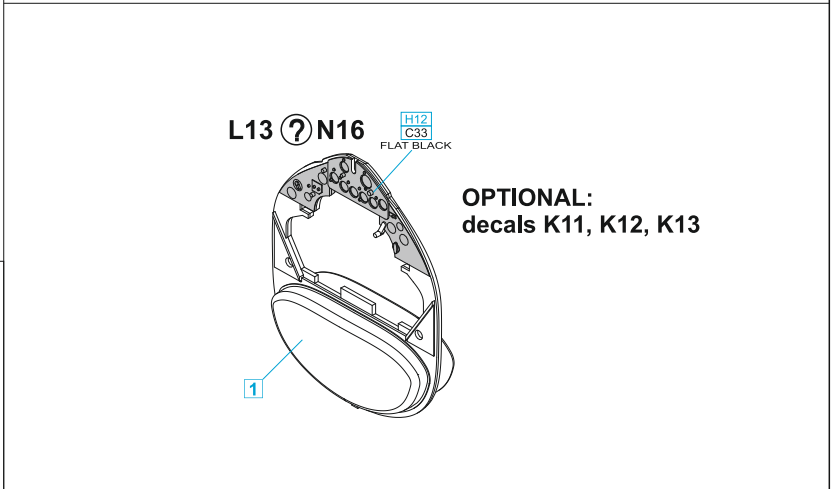
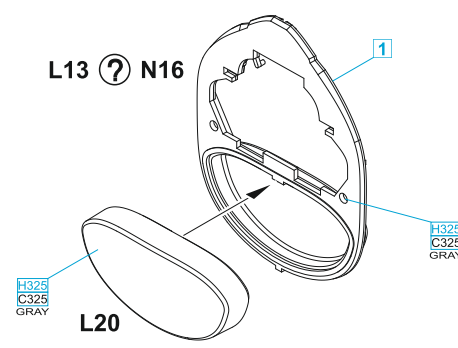

B

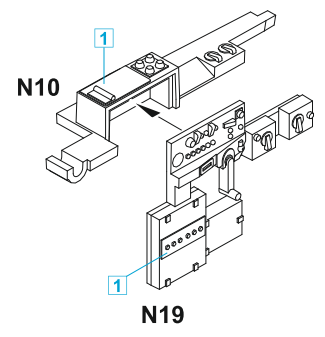

C

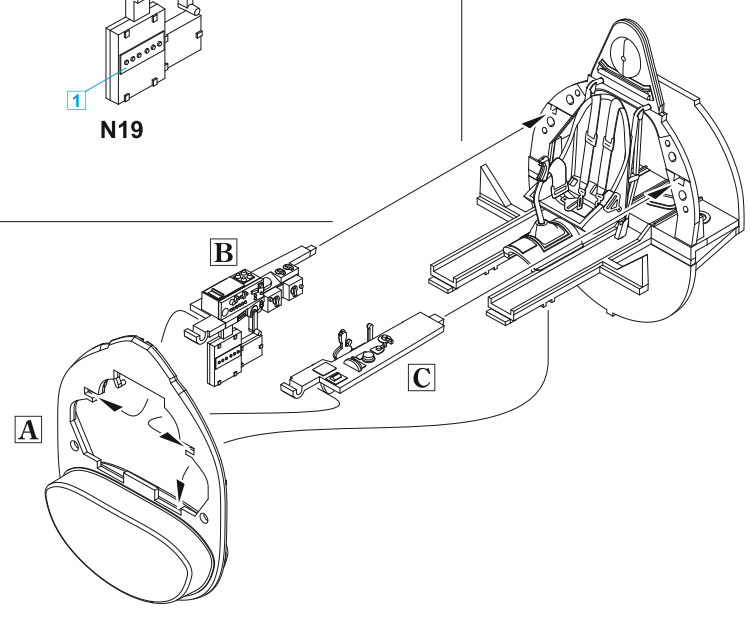
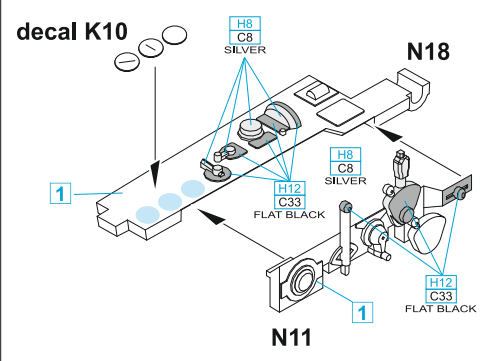

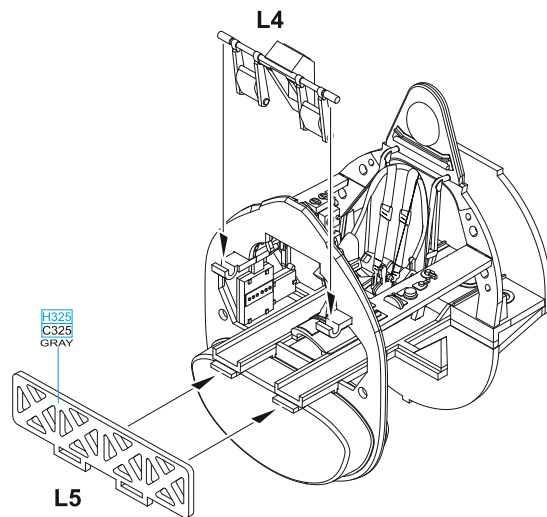
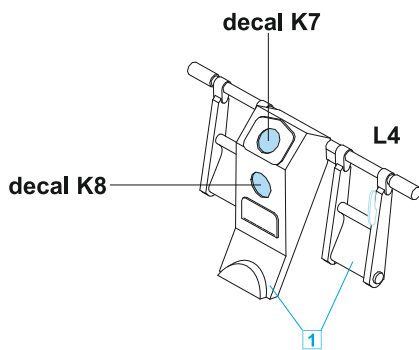
D**E**

2 = H325
C325
GRAY - MARKINGS **A, C, D**
H316
C316
WHITE - MARKING **B**

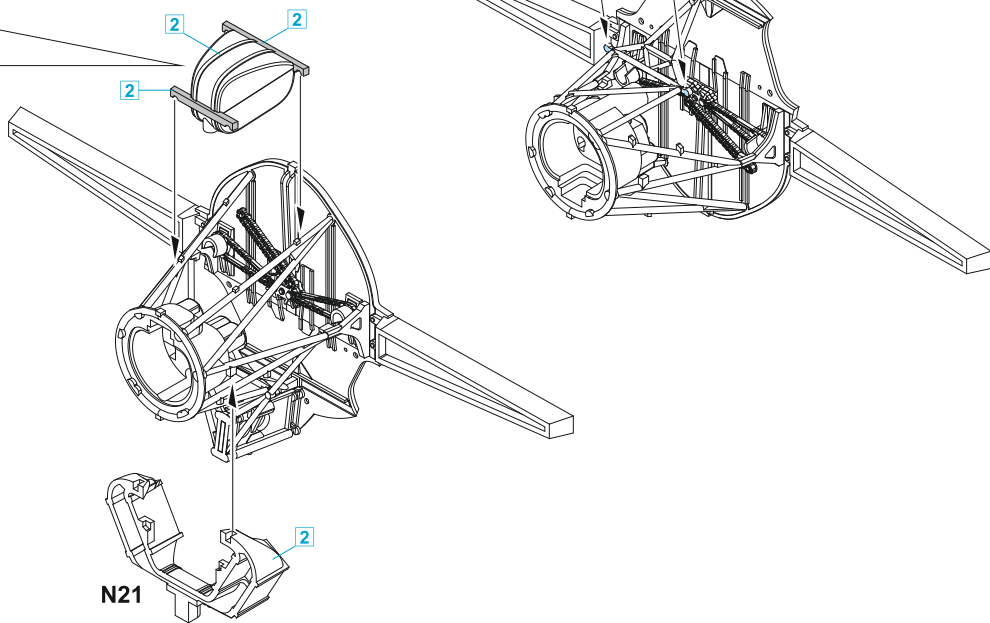
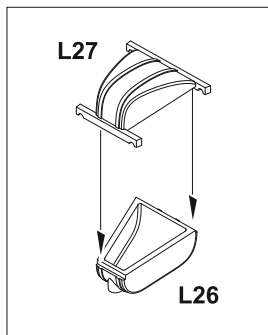
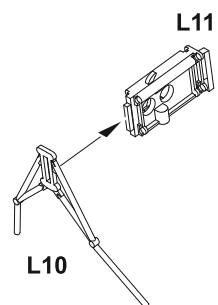
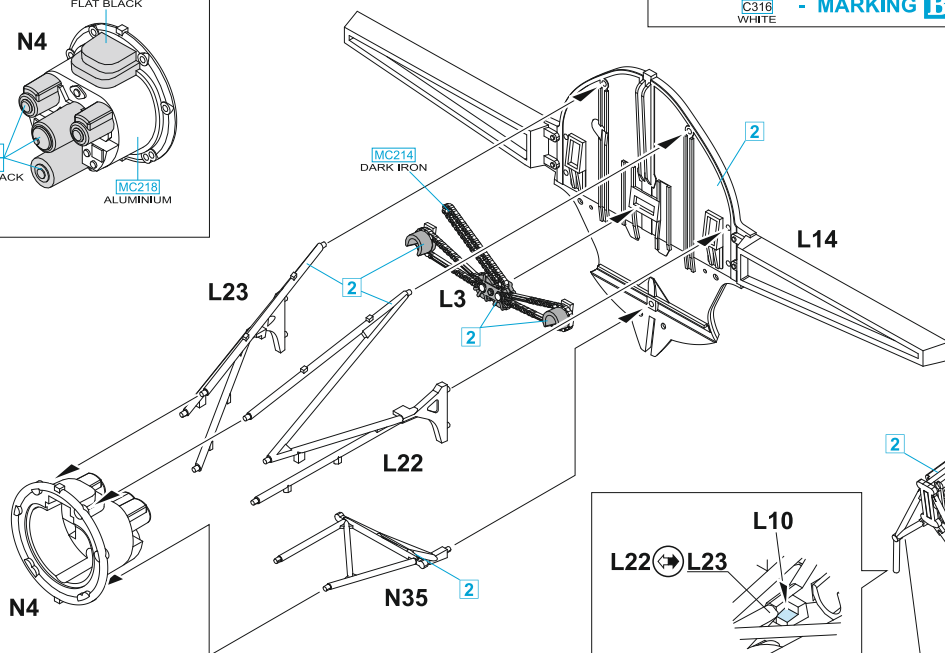
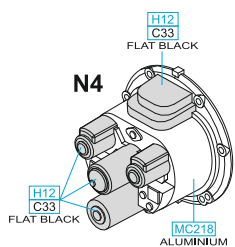

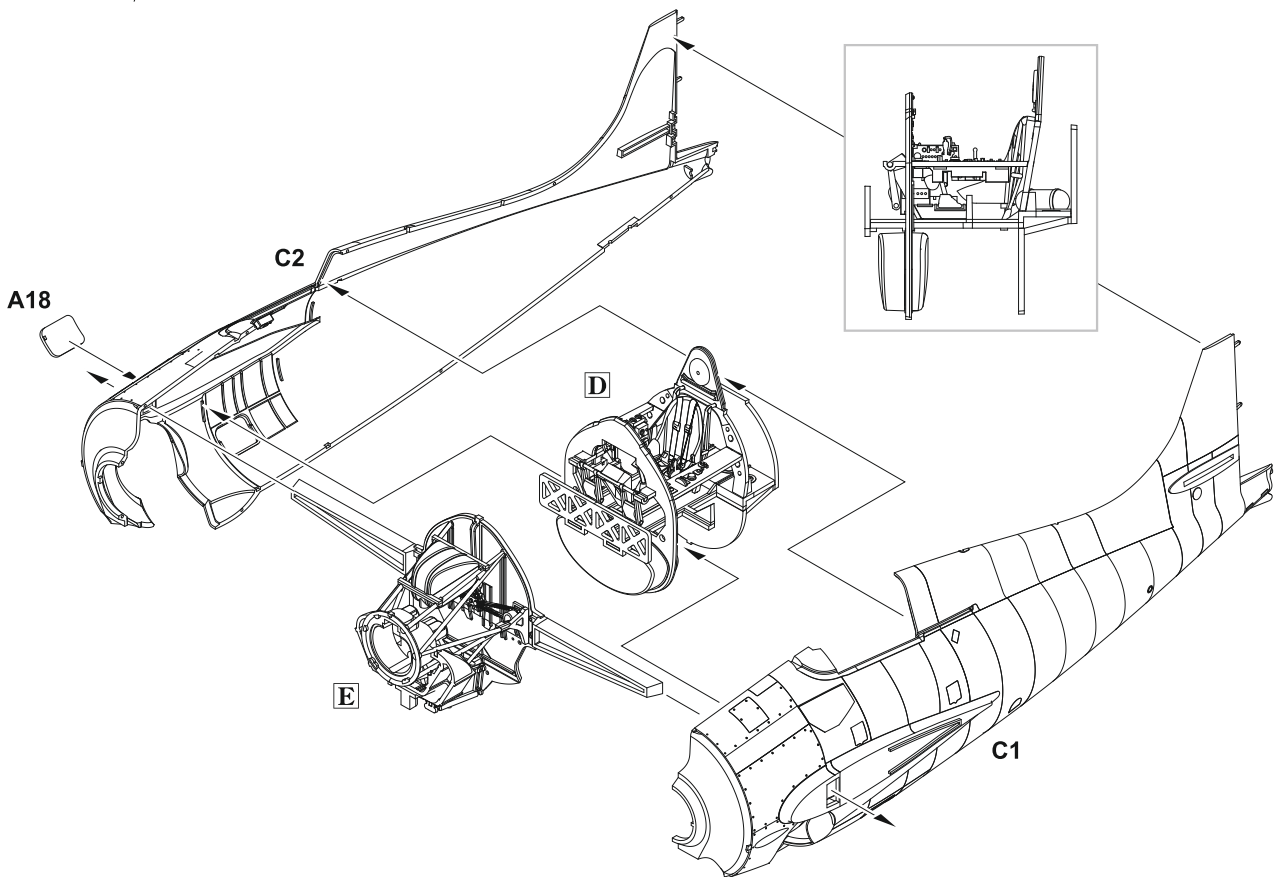
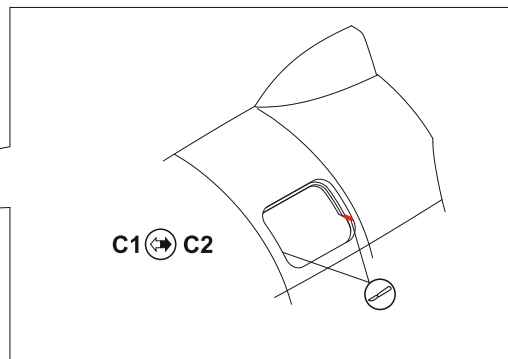
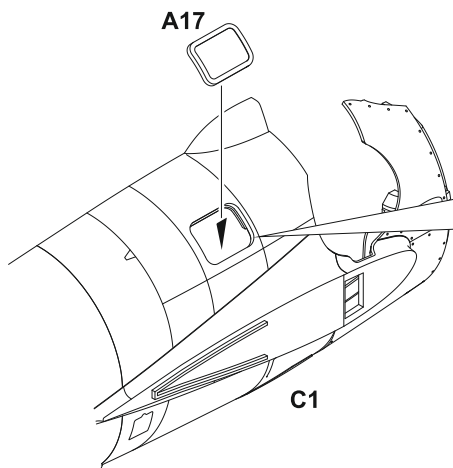
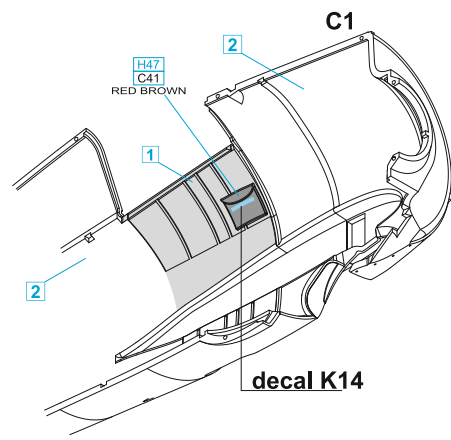
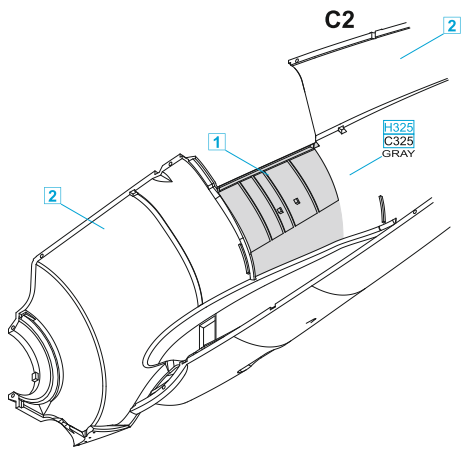

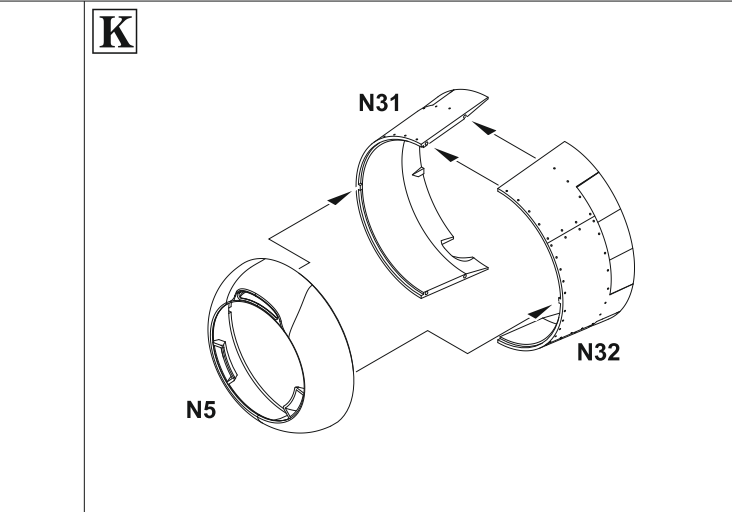
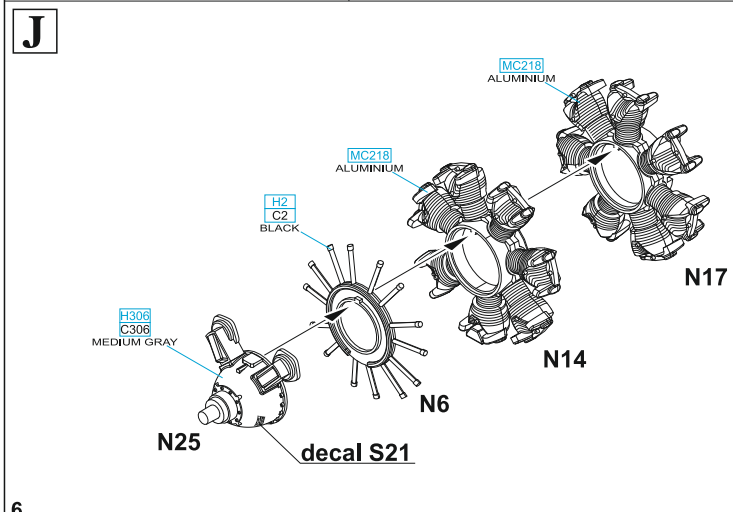
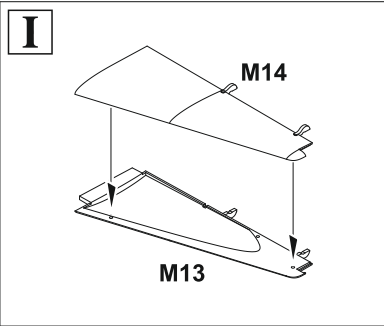
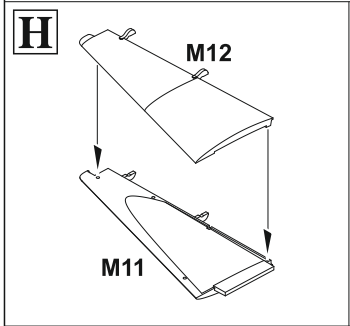
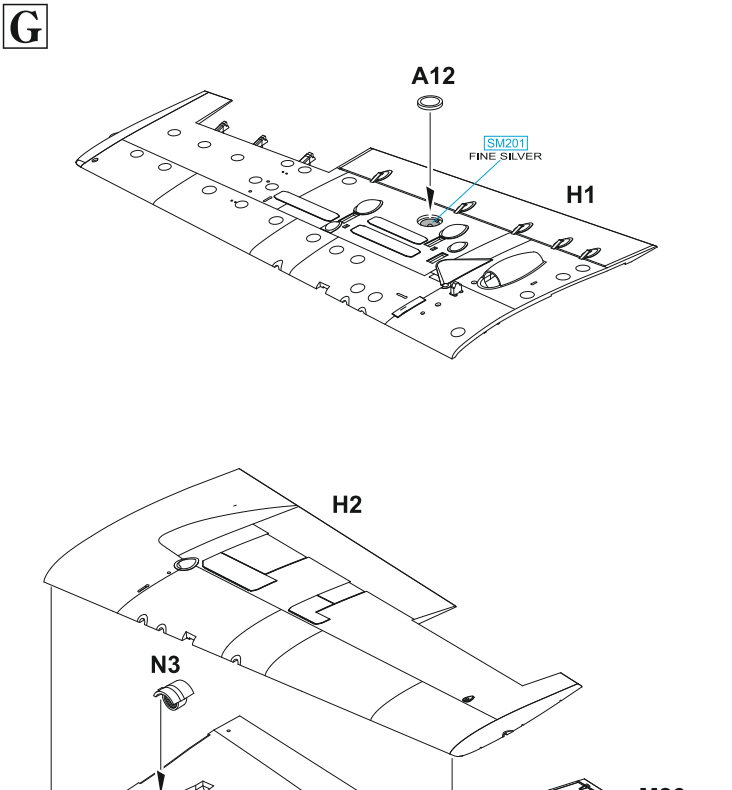
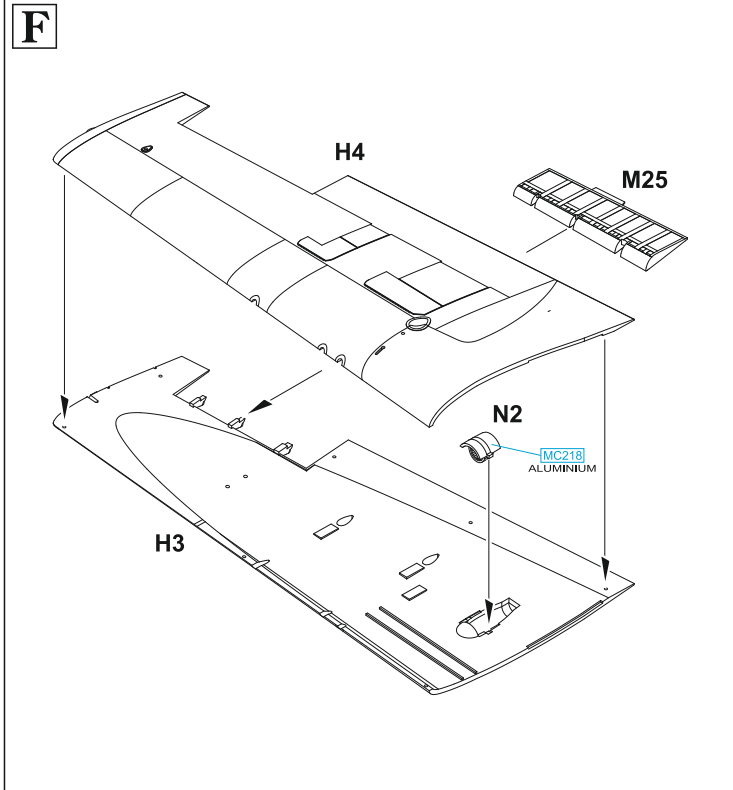
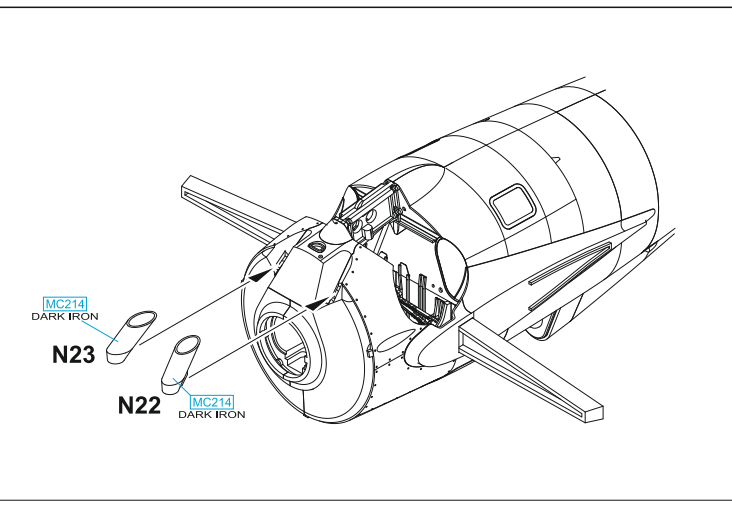
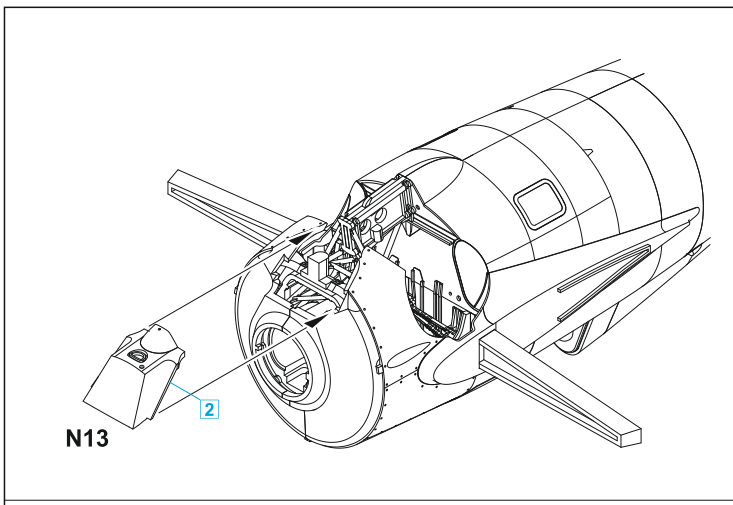

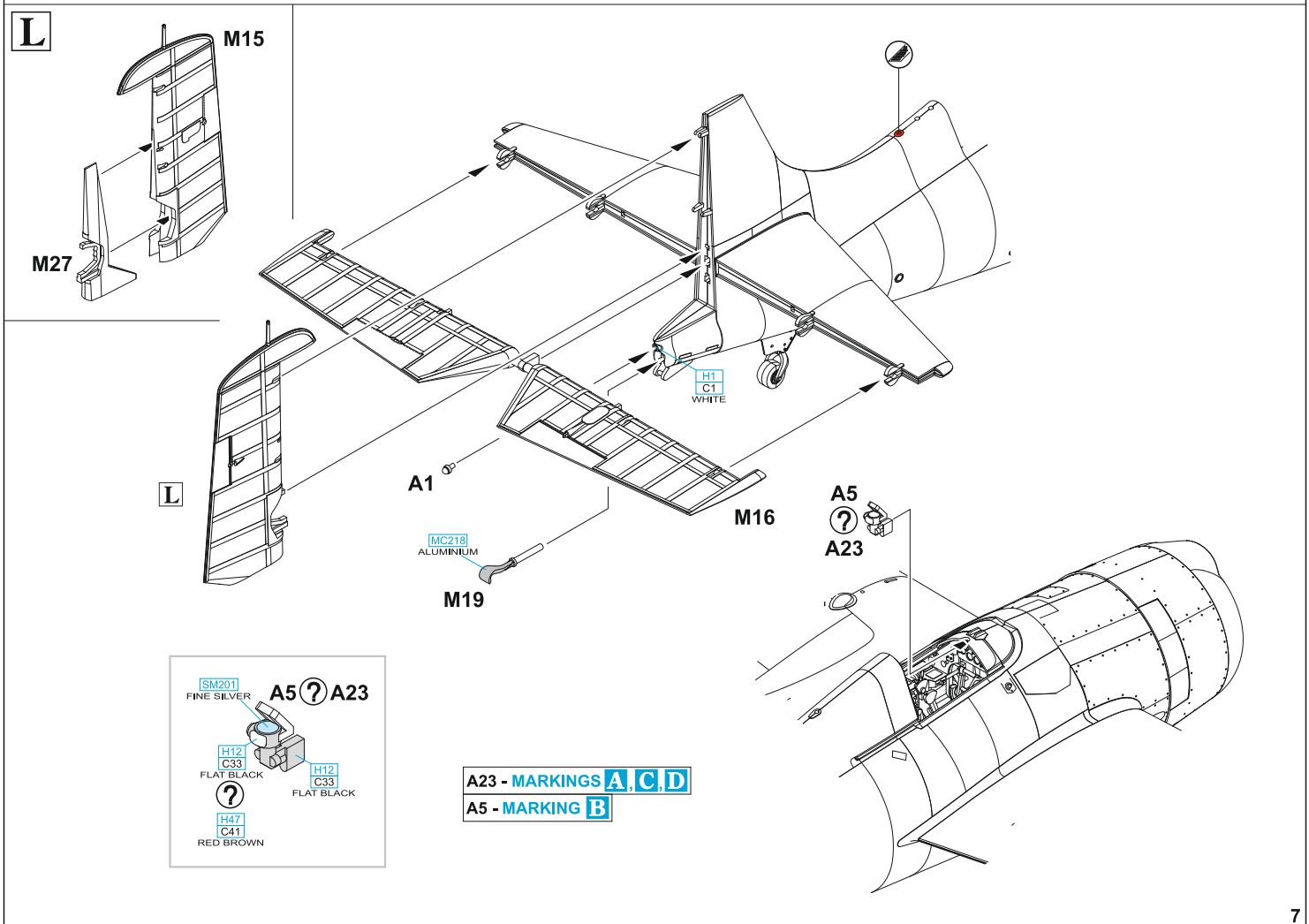
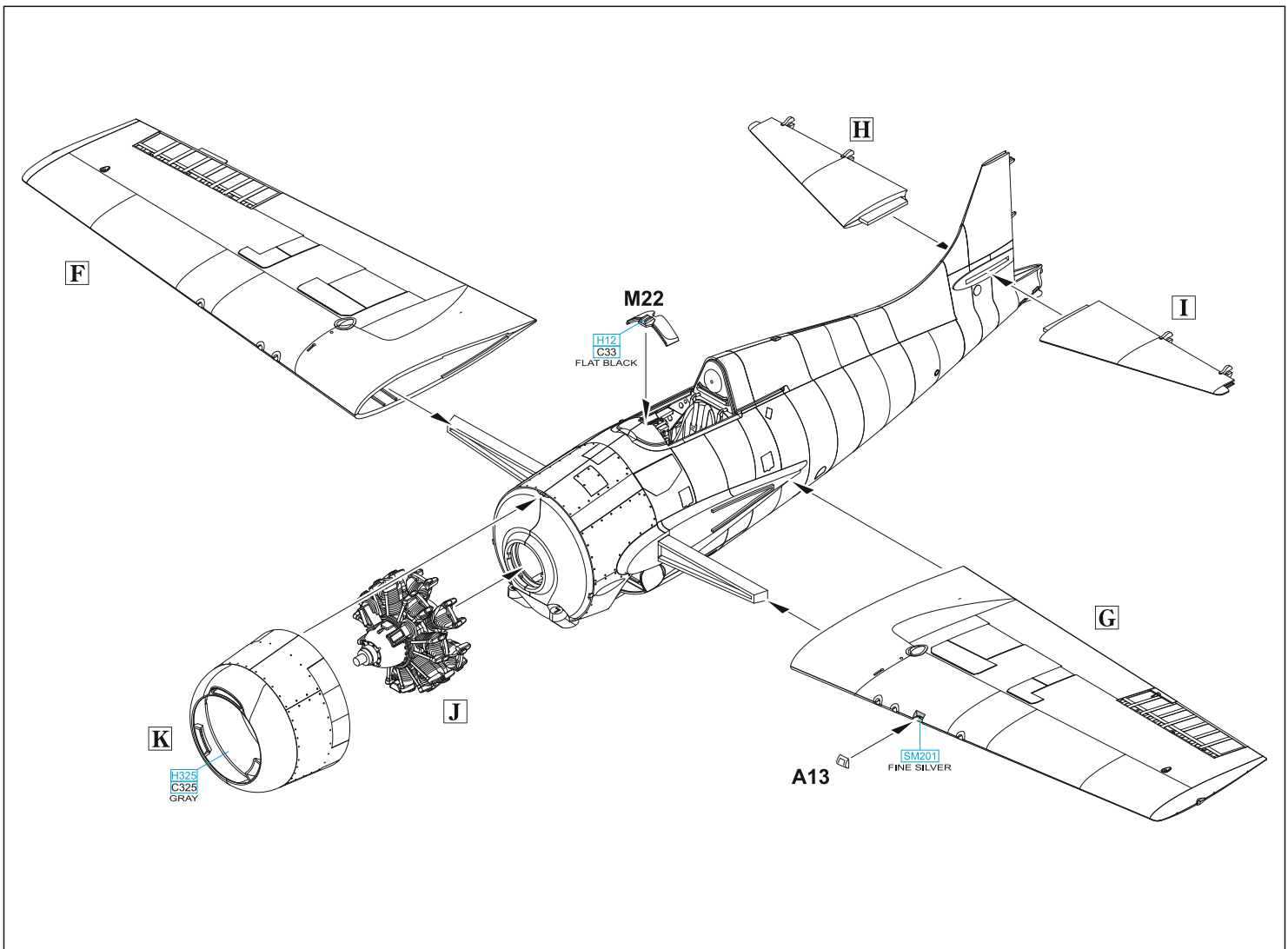

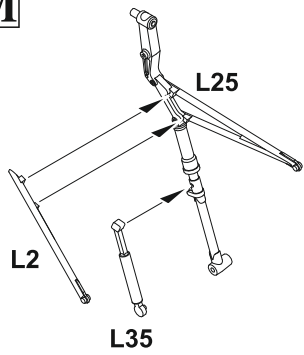
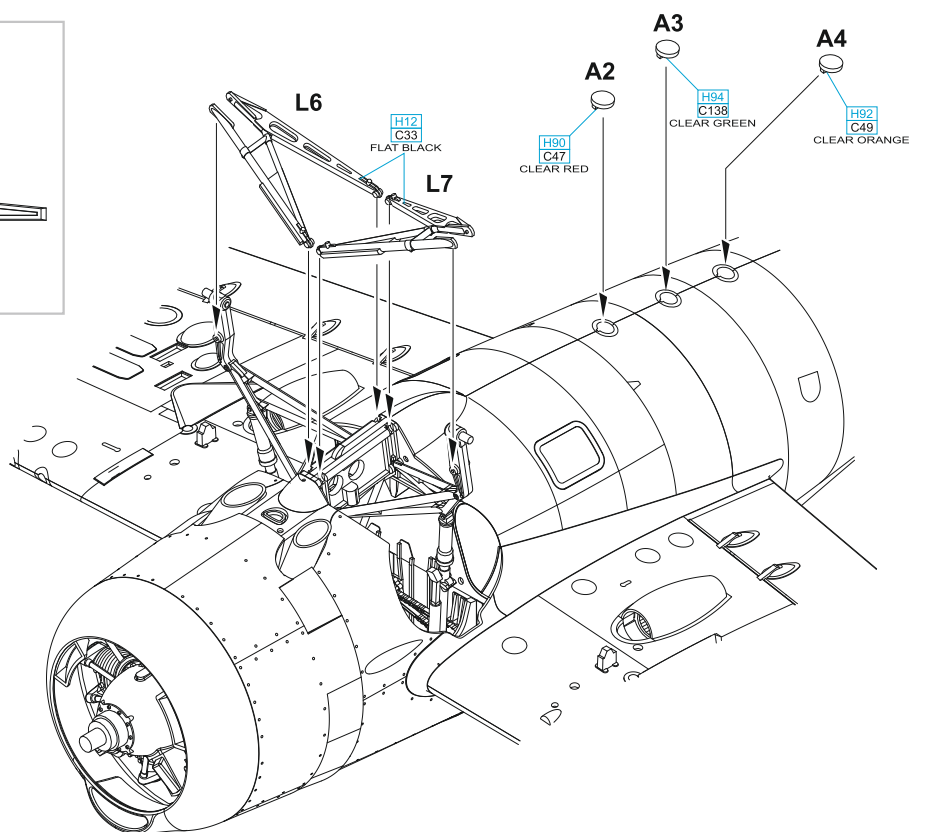
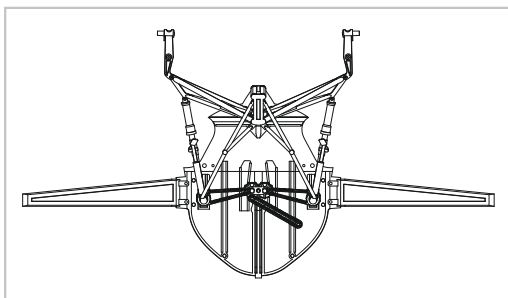
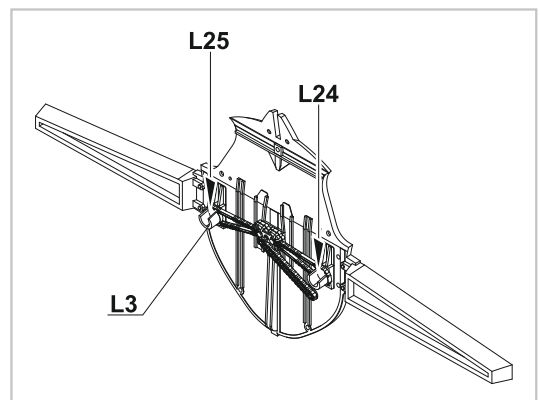
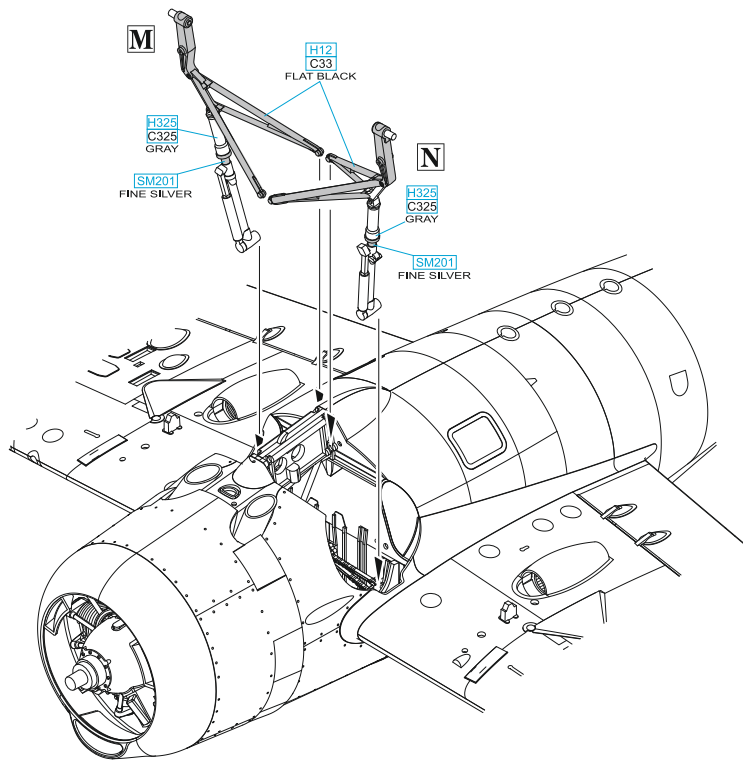
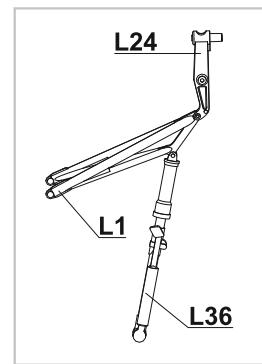
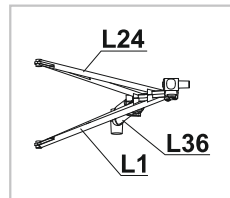
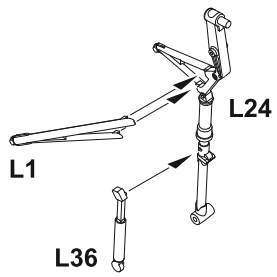
M**N**

O

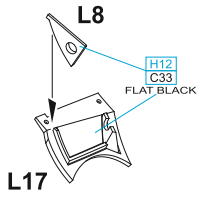

P

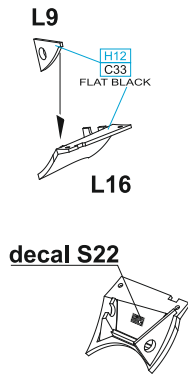

M3 - MARKINGS A, D
M2 - MARKINGS B, C

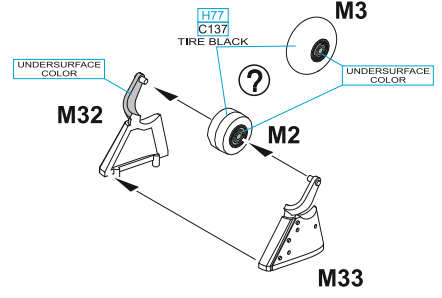

Q 2 pcs.

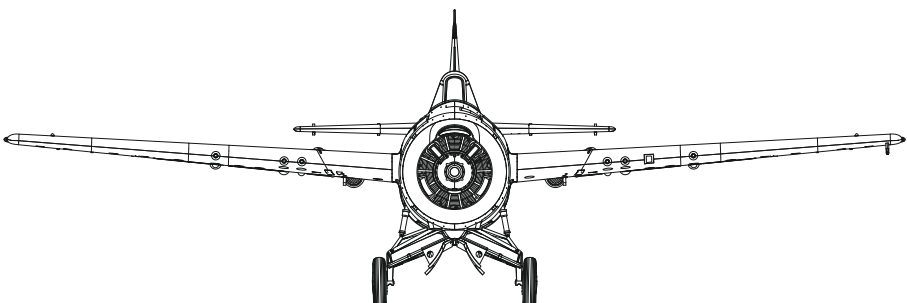
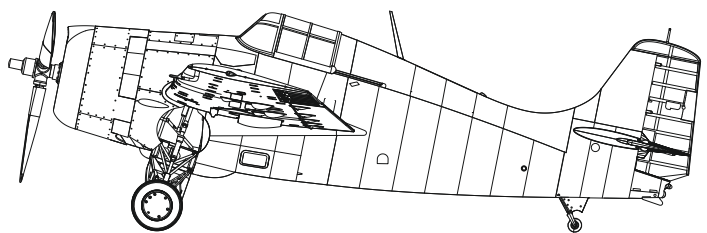
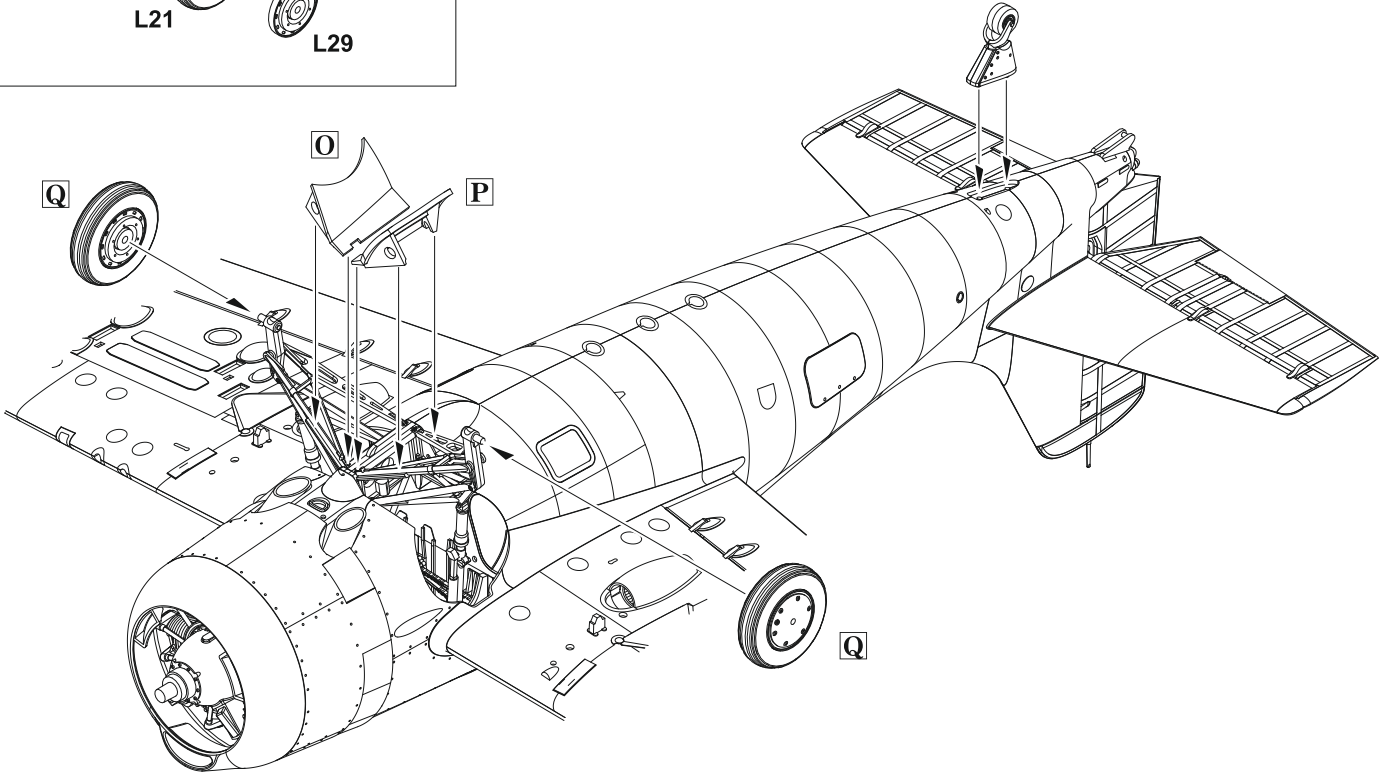
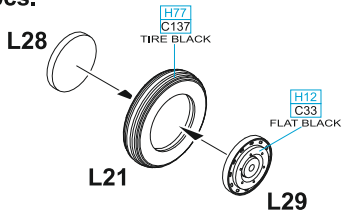

A15 OPEN CANOPY

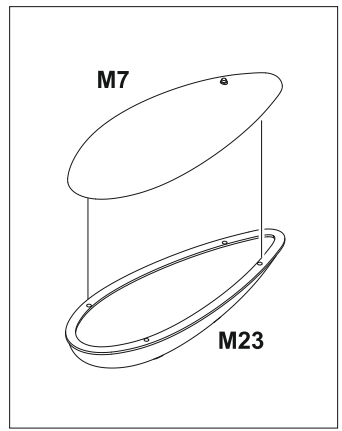
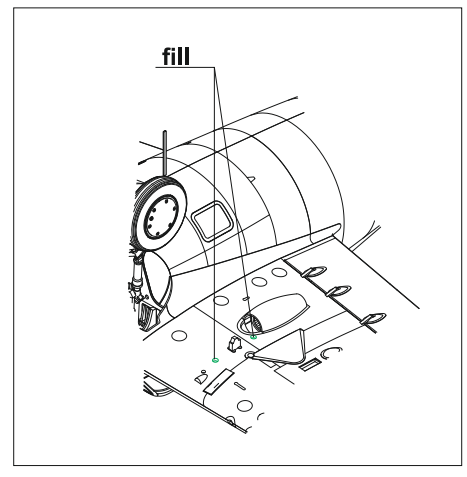
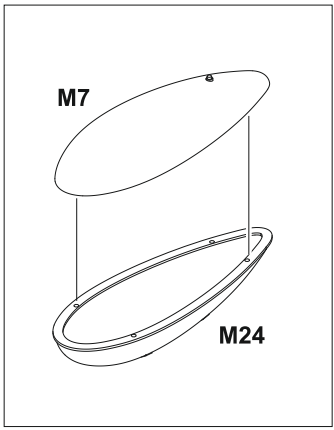
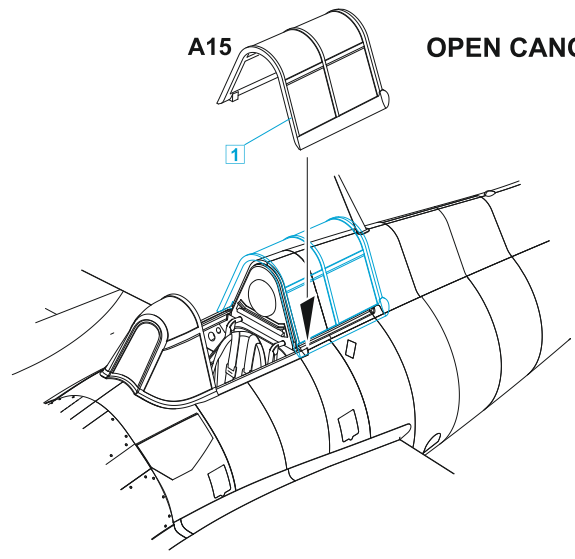

?

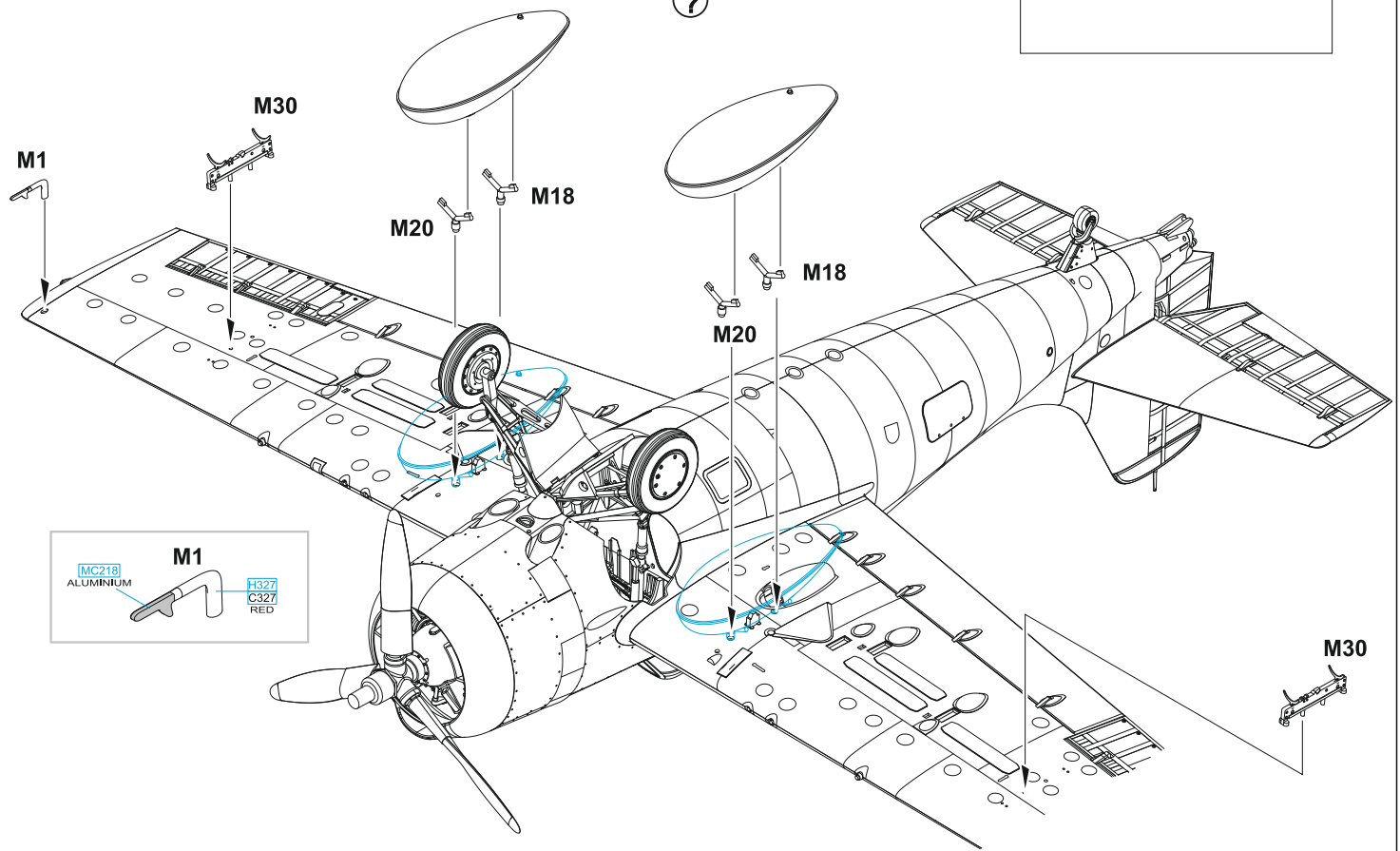

M1
MC218 ALUMINIUM
F327 C327 RED

A VMF-441, Nanumea, Tuvalu, November 1943

Marine Fighting Squadron 441 (VMF-441) was formed on October 1, 1942, at Tutuila, American Samoa, from part of VMF-111 and flew F4F Wildcats. By the end of May 1943, the entire squadron moved to Funafuti in the Ellice Islands, followed by another move to Nanumea Base on September 28, 1943. The squadron moved back to Tutuila in December 1943, where it rearmed to the F4U-1 Corsair. VMF-441 was also known as "The Blackjacks". The unit was credited with a total of 49 aircraft shot down during World War II and was inactivated after the surrender of Japan on July 11, 1946. The Wildcat shown here wore non-standard camouflage with a third shade of Semi-Gloss Sea Blue added to the original older Blue Gray/Light Gray scheme on the upper fuselage and wing surfaces. The nose of the aircraft was decorated with a white Little Joe inscription on the left side of the engine cowling with a dice motif.

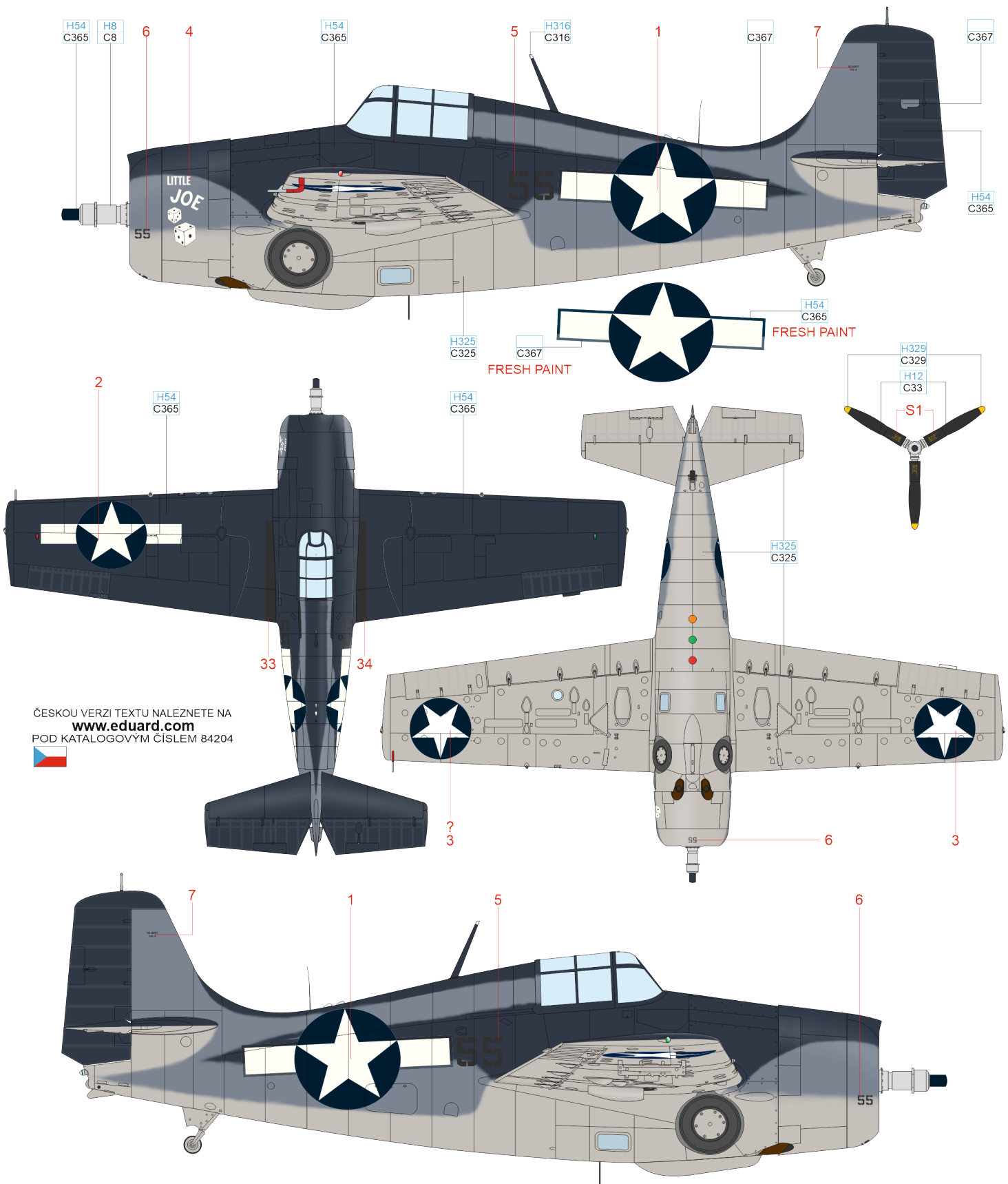

ČESKOU VERZI TEXTU NALEZNETE NA
www.eduard.com
 POD KATALOGOVÝM ČÍSLEM 84204



YELLOW	H329 C329	SILVER	H8 C8
FLAT WHITE	H316 C316	GRAY	H325 C325
		BLUE GRAY	C367
		SEA BLUE	H54 C365
		BLACK	H12 C33

B VC-13, USS Core (CVE-13), August 1943

The Tacoma-built Bogue-class escort carrier USS Core (CVE-13) was commissioned on December 10, 1942, and named after Core Sound. USS Core operated on the west coast off San Diego, but soon joined the Atlantic Fleet to take part in the bloody war against submarines with TBF-1C Avengers and F4F-4 Wildcats on board. Core's first combat cruise in the Atlantic lasted from June 27 to July 31, 1943, during which VC-13 hit a pair of submarines. USS Core and VC-13 scored a total of four submarine kills by the end of 1943, helping to end the good times of the German U-boat fleet. The Wildcats on USS Core carried combination of colors from the factory blue-grey NS through light grey NS as well as both the then-new ASWN I and II schemes designed for the Atlantic. The aircraft shown, with the black identification number 3 on the rudder, had a three-tone camouflage, i.e. ASWN I scheme, and was sporting red outlined insignias. These were repainted with Insignia Blue in September 1943.

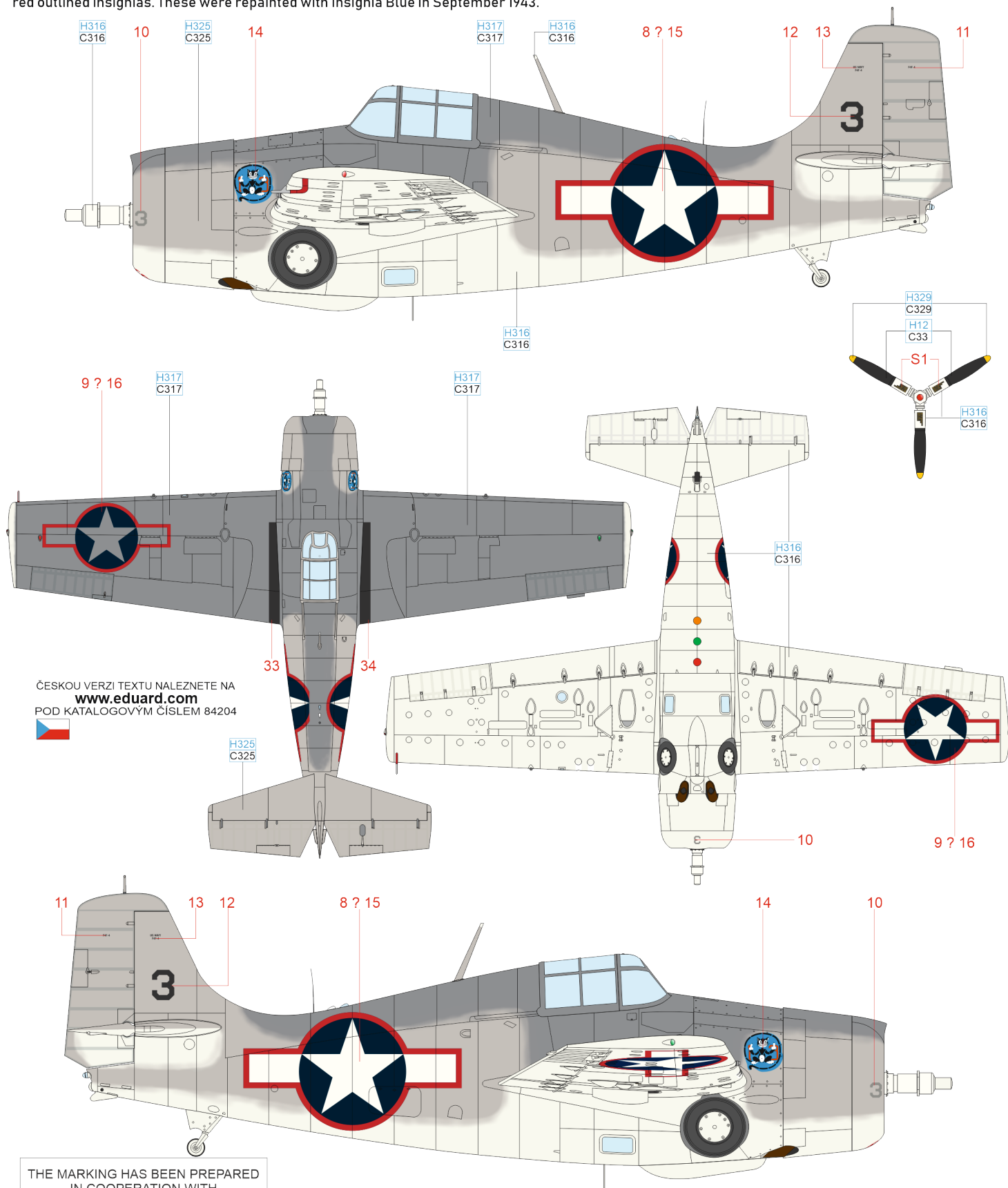

ČESKOU VERZI TEXTU NALEZNETE NA
www.eduard.com
 POD KATALOGOVÝM ČÍSLEM 84204



H325
C325

THE MARKING HAS BEEN PREPARED
 IN COOPERATION WITH

FLAT WHITE	H316 C316	GRAY	H317 C317	GRAY	H325 C325	YELLOW	H329 C329	BLACK	H12 C33
------------	--------------	------	--------------	------	--------------	--------	--------------	-------	------------

C VGF-29, Lt Cdr John T. Blackburn, USS Santee (CVE-29), November 1943

John Thomas Blackburn (born January 24, 1912) became first commanding officer of famous VF-17 Jolly Rogers Squadron flying F4U Corsairs. Prior to that, he had managed to achieve fame and ace status with Wildcats. He graduated from the US Naval Academy in 1933 and served as flight instructor when the USA entered the war in 1941. Although anxious to get to combat, he was relegated to fly Buffalos in Miami and had to apply several times for assignment with combat unit. He was tasked to set up VGF-29 as its CO on the new escort carrier USS Santee. After the pilots acquainted themselves with Wildcats at Pungo, Virginia, the Squadron embarked aboard USS Santee in October 1942 to participate in Operation Torch. The first combat was a disaster, as pilots could not find the target due to poor weather. More to it, damaged homing equipment aboard Santee forced them to ditch or force-land their Wildcats. Blackburn himself floated adrift in a life raft for three days before he was rescued by a destroyer. Shortly thereafter, Blackburn was ordered to set up a new unit, the VF-17, the second squadron to fly F4U Corsairs in combat. Blackburn achieved 11 victories in WWII and became Commander Air Group of CAG 74 aboard the new USS Midway (CVB-41) in 1945 and he commanded the ship from 1958 to 1959. After the war he worked at the Pentagon and was one of the first jet pilots in the Navy. He retired in 1962 and began growing wine grapes and raising the Golden Retrievers in California. He died on March 21, 1994.

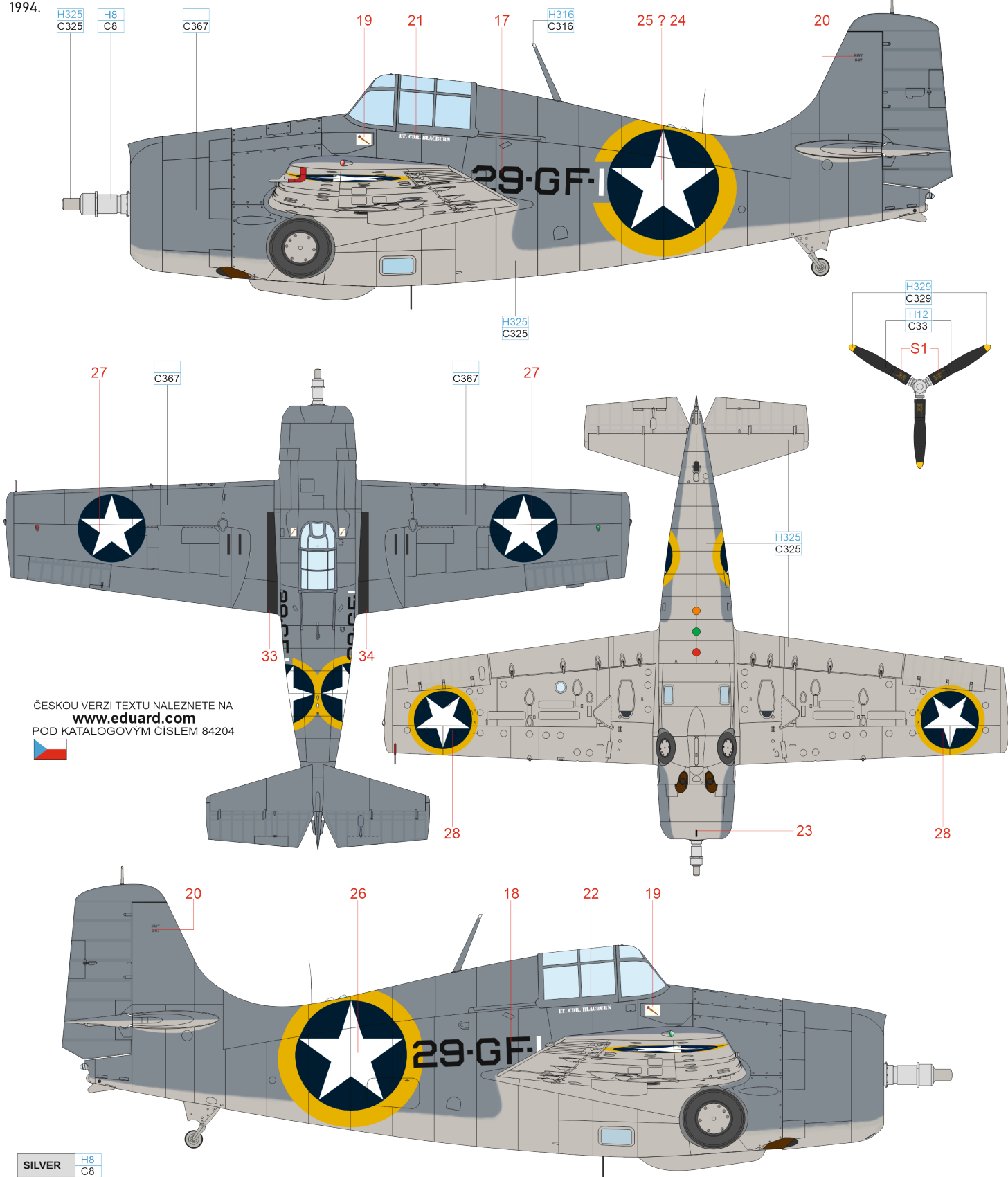

ČESKOU VERZI TEXTU NALEZNETE NA
www.eduard.com
 POD KATALOGOVÝM ČÍSLEM 84204



SILVER	H8 C8	FLAT WHITE	H316 C316	BLUE GRAY	C367	GRAY	H325 C325	YELLOW	H329 C329	BLACK	H12 C33
--------	----------	------------	--------------	-----------	------	------	--------------	--------	--------------	-------	------------

D VMF-111 (121), 2Lt. Thomas Mann, Samoa, Spring 1943

Marine Fighting Squadron 121 (VMF-121) was activated on June 24, 1941 and adopted the nickname The Green Knights. They began combat operations with F4F Wildcats, which they changed for F4U Corsairs later. They took part in the battle for Guadalcanal starting October 1942 and also fought from the forward air bases on Bougainville and Emirau. On September 15, 1944, the Green Knights landed on Peleliu and were fighting from this base until July 25, 1945. The unit was deactivated on September 9, 1945. During the war, fourteen pilots of VMF-121 became fighter aces, and the whole unit downed 208 Japanese aircraft, 165 of them while flying Wildcats. Marine Second Lieutenant Thomas H. Mann, Jr., moved to VMF-121 from VMF-224 and became an ace in the fighting over Guadalcanal with five victories on his account. On November 11, 1942, he took off with others to intercept a formation of Japanese Aichi Type 99 bombers. He managed to shoot down three of them prior to being shot down and lost seven teeth in landing on water, which added the pain to his wound he suffered from enemy fire. Mann managed to reach the beach of a small island in the Tulagi archipelago and got back with the help of natives in a canoe. At the end of the WWII, he amassed ten aerial victories.

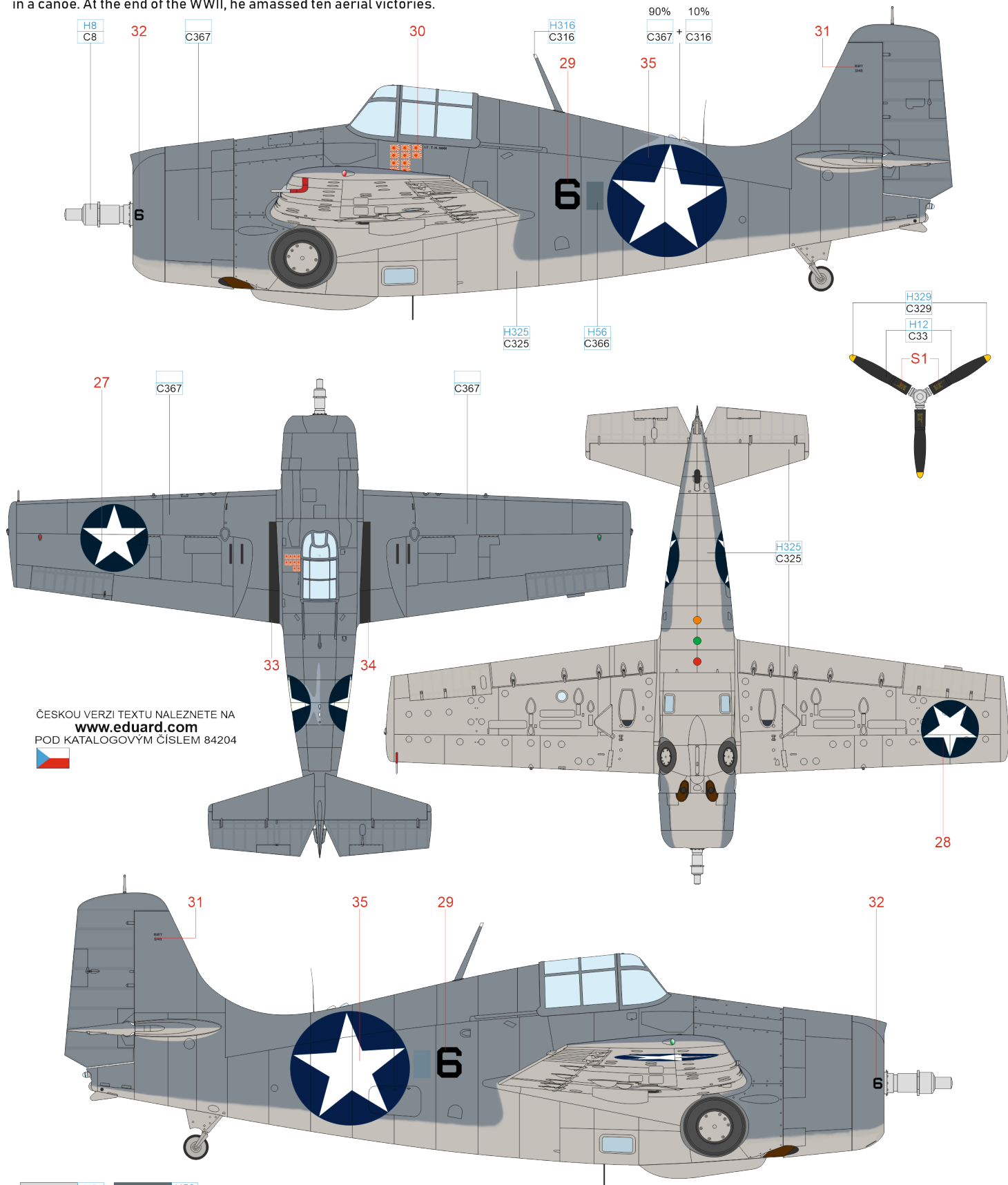

ČESKOU VERZI TEXTU NALEZNETE NA
www.eduard.com
 POD KATALOGOVÝM ČÍSLEM 84204



SILVER	H8 C8	INTERMEDIATE BLUE	H56 C366
FLAT WHITE	H316 C316	BLUE GRAY	C367
GRAY	H325 C325	YELLOW	H329 C329
BLACK	H12 C33		

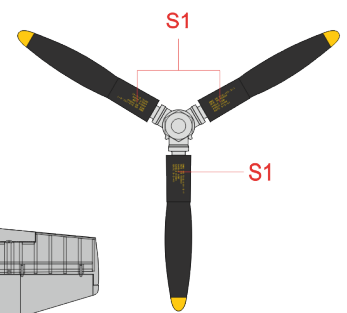
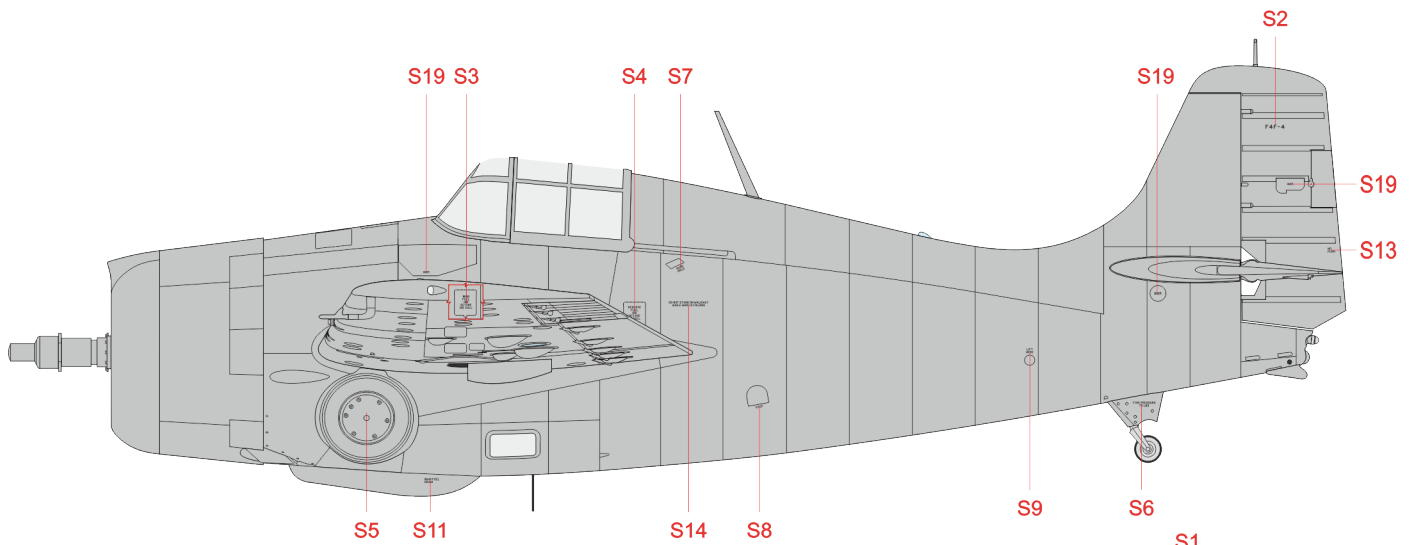

Stenciling of the Wildcats was rather individual. Look at the reference whenever possible.

