

# P-51B Mustang™

eduard

1/48 Scale Plastic Model Kit



Produced under license

Boeing, P-51 Mustang, their distinctive logos, product markings and trade dress are trademarks of The Boeing Company.

**WEEKEND**  
edition



item # 84209

The P-51 Mustang is one of the best fighters of all time and although an American airplane, its genesis owes a lot to Great Britain. The main change in the development of the type occurred when the original Allison engine was replaced by the R&R Merlin one. The new unit literally unlocked the whole potential of the already excellent airframe as the P-51B/C version was born.

It started in 1940, when British Buying Committee asked North American Aviation (NAA) to build the Curtiss P-40s for the RAF. NAA president James Kindelberger offered Britons the development of a much better plane instead. The Committee agreed and so the design team led by chief designer Edward Schmued, who was a German immigrant with Austrian roots, started to work. The preliminary design was approved on May 4, 1940, final assembly and engine installation began on September 9 (just 127 days after approval) and the first flight of the NA-73X prototype followed on October 26.

#### Innovative fighter

The Allison V-1710-39 one-stage, one-speed supercharged liquid-cooled in-line engine rated at 1,100 HP was chosen for the new fighter and the designers creating as narrow and sleek a fuselage as possible did their best to lower the drag. For the same reason they decided to use an innovative laminar flow airfoil, which lowers the drag indeed, but, on the other hand, requires a smooth surface to work well. That necessitated putty and sand the leading area of the wing. Another innovative design feature was the radiator belly under the fuselage which even developed some additional thrust thanks to the Meredith effect. Armament consisted of two guns in the nose and four in the wings, all of them .50 caliber Brownings (the Mk. Ia variant had four 20mm cannons). Britons chose the name Mustang for the new aircraft, later adopted by USAAF as well. The RAF received the first Mustangs Mk.I in October 1941. The performance was found satisfactory, as the Mustang was faster than the Spitfire Mk.V and had more than double the range. On the other side, the Allison engine reached its maximum power at only 11,800 ft (3,597 m) because of its one stage supercharger. Above this level the engine performance decreased rapidly. As the aerial combats occurred much higher, the RAF decided to use their Mustangs in the reconnaissance role and the US Army Air Corps, interested in the new type as well (but bound to the contract to build P-40, P-39 and P-38 pursuits), asked the NAA to convert the Mustang as a dive bomber with wing dive brakes (the A-36 variant).

#### Merlin magic

To solve the high altitude weakness, the engineering began in Great Britain to fit the Mustang with the two-stage, two-speed

supercharger Merlin 61 engine. The trials of the Mustang X prototype, fitted with Merlin 65 finally, found the level speed increased to 433 mph (697 km/h) at 22,000 ft (6,700 m), thus 100 mph (161 km/h) better than Mustang Mk.I. As it was obviously the way to further develop the Mustang, the NAA started its own work, using license-built Packard-Merlin engines. The need for an intercooler of the two-stage supercharger necessitated a bigger radiator duct and the intake for the carburetor moved from the top of the nose to the bottom. Another change included the removal of the fuselage guns and adding two in the wing. The production started at the Inglewood plant as P-51B on May 1943 and at the new production line at NAA Dallas plant as P-51C in August 1943. The supplies of the new version to RAF continued as Mustang Mk. III.

#### Ace maker and infinite warrior

The first Mustang aerial victory was achieved on August 19, 1942, when Flight Officer Hills shot down an Fw 190. It was the beginning of the incredible tally of 4,950 enemy aircraft shot down by Mustang pilots during World War II. Of them, 251 achieved the "ace" status. The most successful pilot of P-51 was George Preddy Jr., recording 24 of his 27 aerial victories flying Mustang, followed by John C. Meyer and John J. Woll with 21 kills each. Famous Charles Yeager, the first man to break the sonic barrier in 1947, was the first pilot of P-51D to become ace in just one day, after recording five kills on October 12, 1944.

#### The kit: P-51B Mustang Birdcage canopy

The P-51B/C were great fighters but lacked backward visibility and their guns jammed far too often. The problems with visibility were down to the so called Birdcage canopy, which was aligned with the high ridge of the rear fuselage, thus preventing pilot to observe the area behind. Still, the P-51B/C was genuine long-range fighter changing the daytime bomber escorts over the occupied territory dramatically. The problem with visibility was partly solved by so called „Malcolm Hood“ frameless semi-bubble canopy sliding to the rear on rails instead of opening on hinges to the right side. The canopy was not a factory solution, it was in fact invented by NAA engineers working in the UK. The other teething problem of P-51B/C, jamming of the guns, was solved a little bit later with the P-51D/K version.

ATTENTION



UPOZORNĚNÍ



ACHTUNG



ATTENTION



注意



Carefully read instruction sheet before assembling. When you use glue or paint, do not use near open flame and use in well ventilated room. Keep out of reach of small children. Children must not be allowed to suck any part, or pull vinyl bag over the head.



Před započítím stavby si pečlivě prostudujte stavební návod. Při používání barev a lepidel pracujte v dobře větrané místnosti. Lepidla ani barvy nepoužívejte v blízkosti otevřeného ohně. Model není určen malým dětem, mohlo by dojít k požití drobných dílů.

INSTRUCTION SIGNS \* INSTR. SYMBOLS \* INSTRUKTION SINNBILDEN \* SYMBOLES \* 記号の説明

OPTIONAL  
VOLBABEND  
OHNOUTSAND  
BROUSITOPEN HOLE  
VYVRTAT OTVORSYMETRICAL ASSEMBLY  
SYMETRICKÁ MONTÁŽREMOVE  
ODRÍZNOUTREVERSE SIDE  
OTOČITAPPLY EDUARD MASK  
AND PAINT  
POUŽÍT EDUARD MASK  
NABARVIT**PLEASE CHECK THE LATEST VERSION OF THE INSTRUCTIONS ON [www.eduard.com](http://www.eduard.com)**

PARTS



DÍLY



TEILE



PIÈCES



部品

F&gt;

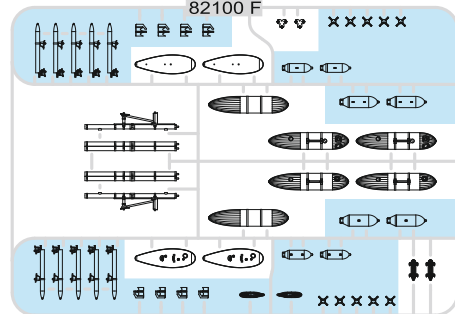

PLASTIC PARTS

K&gt;

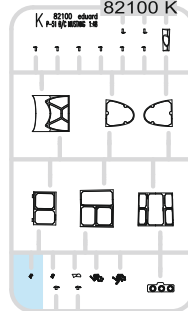

M&gt;

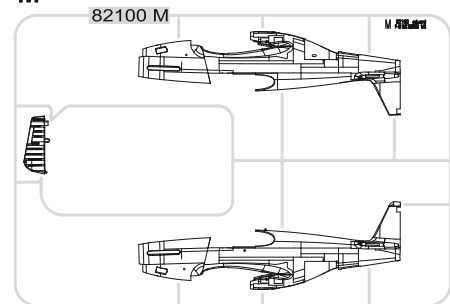

O&gt;

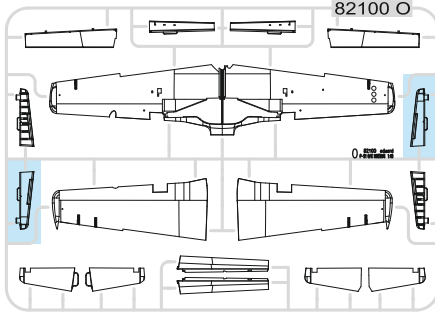

P&gt;

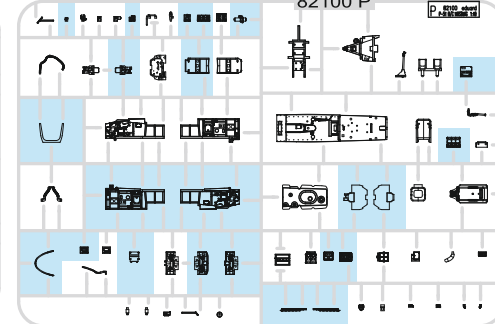

R&gt;

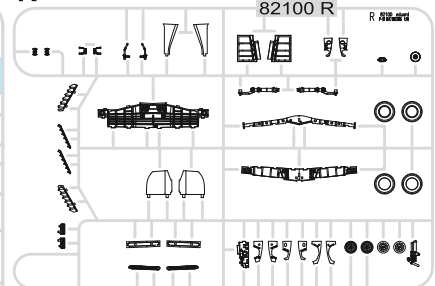

S&gt;

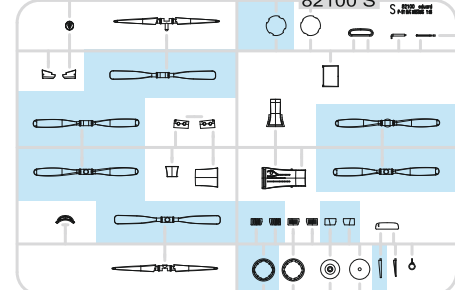

-Parts not for use. -Teile werden nicht verwendet. -Pièces à ne pas utiliser. -Tyto díly nepoužívejte při stavbě. - 使用しない部品

COLOURS



BARVY



FARBEN



PEINTURE



色

GSI Creos (GUNZE)		
AQUEOUS	Mr.COLOR	
H1	C1	WHITE
H8	C8	SILVER
H11	C62	FLAT WHITE
H12	C33	FLAT BLACK
H15	C65	BRIGHT BLUE
H27	C44	TAN
H47	C41	RED BROWN
H52	C12	OLIVE DRAB
H53	C13	NEUTRAL GRAY
H58	C351	INTERIOR GREEN
H76	C61	BURNT IRON

GSI Creos (GUNZE)		
AQUEOUS	Mr.COLOR	
H77	C137	TIRE BLACK
H90	C47	CLEAR RED
H92	C49	CLEAR ORANGE
H94	C138	CLEAR GREEN
H327	C327	RED
H329	C329	YELLOW
	C352	CHROMATE YELLOW
Mr.COLOR SUPER METALLIC		
	SM201	SUPER FINE SILVER
	SM203	SUPER IRON

1 = 90% + 10%

H58 C351 INTERIOR GREEN	H12 C33 FLAT BLACK
-------------------------------	--------------------------

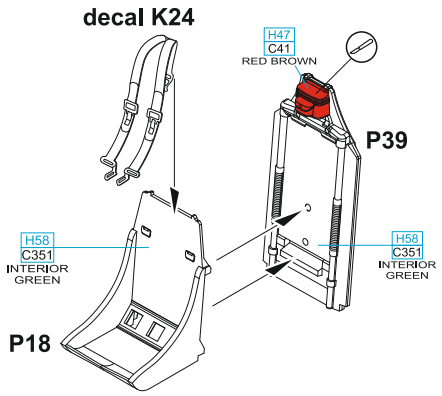

MARKINGS **A,C**

**decal K24**

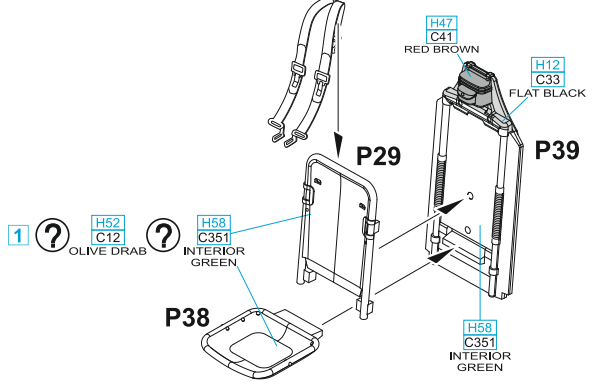

MARKINGS **B,D**

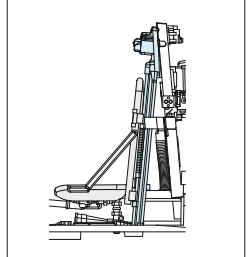
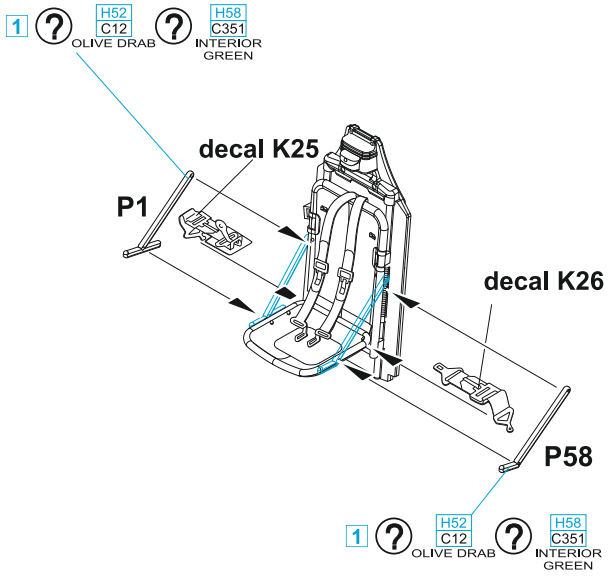
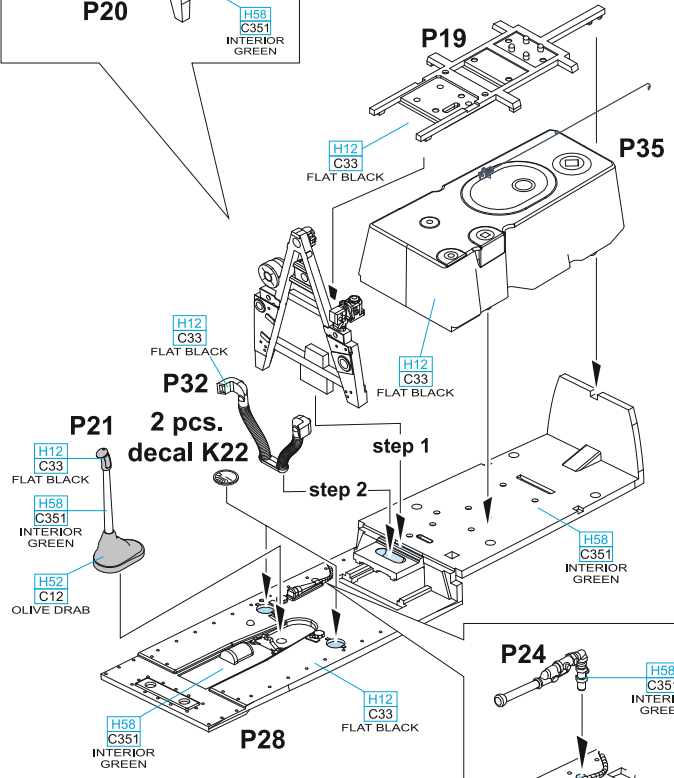
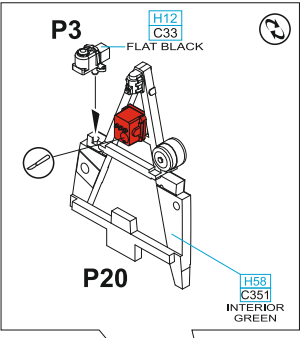

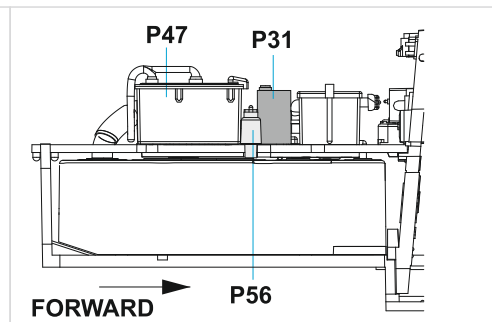
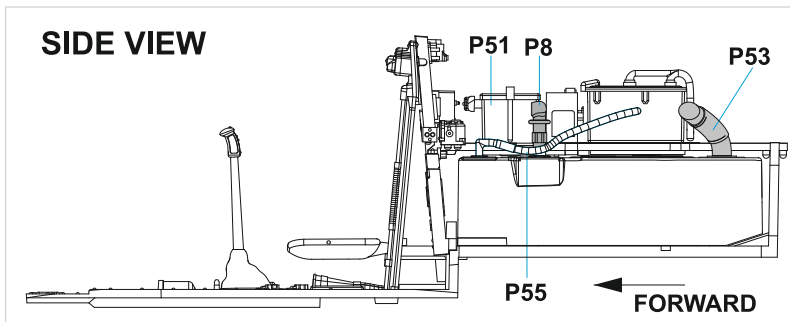
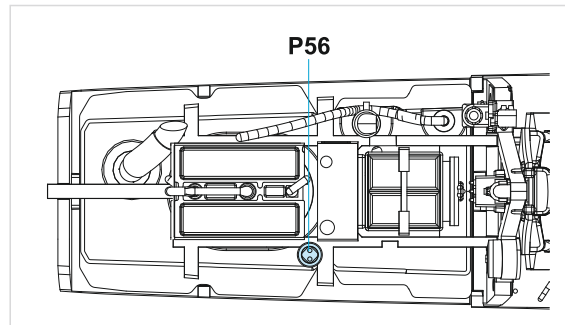
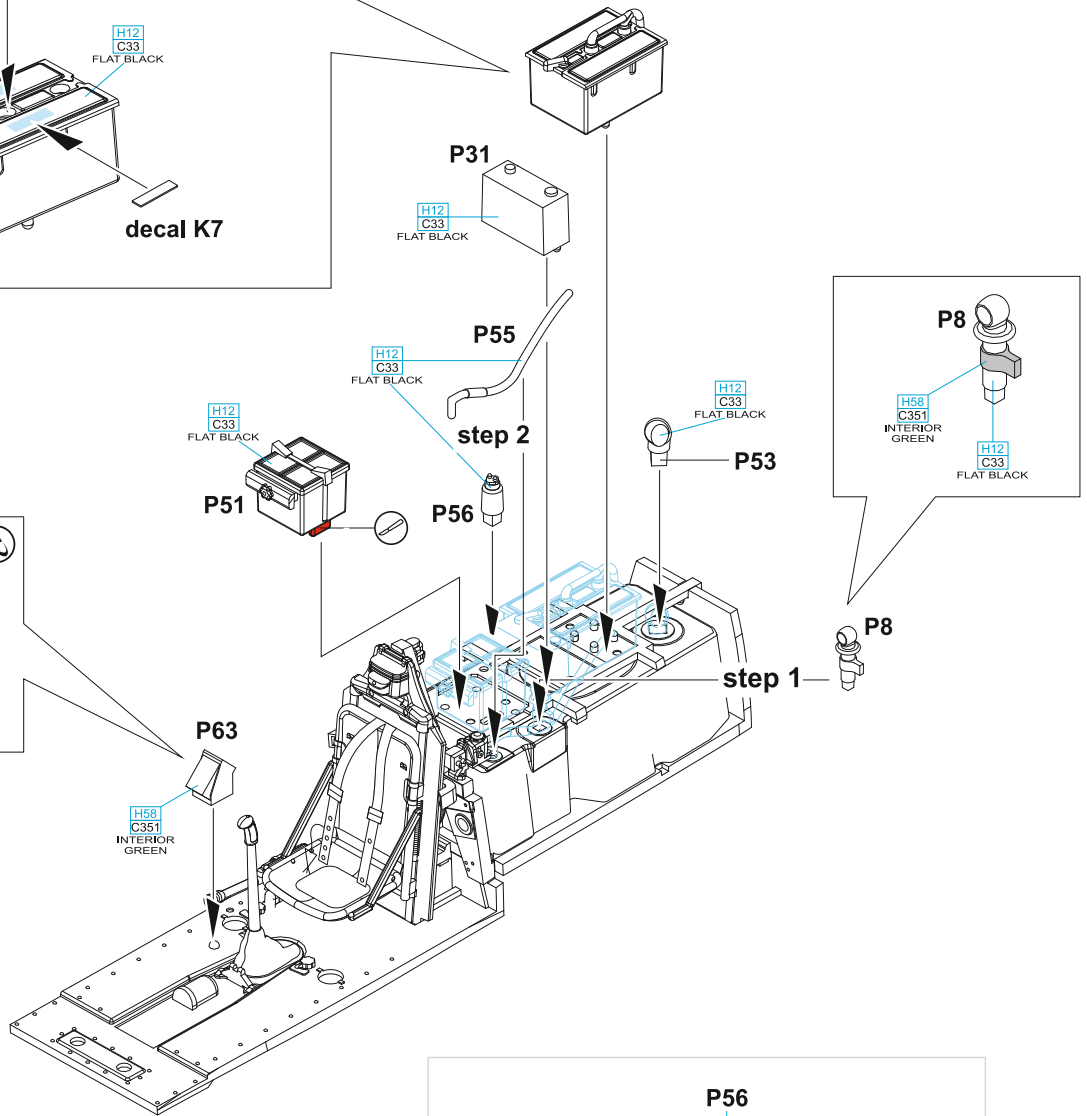
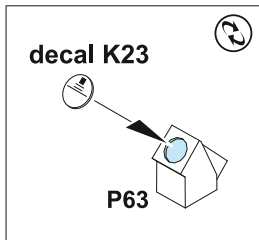
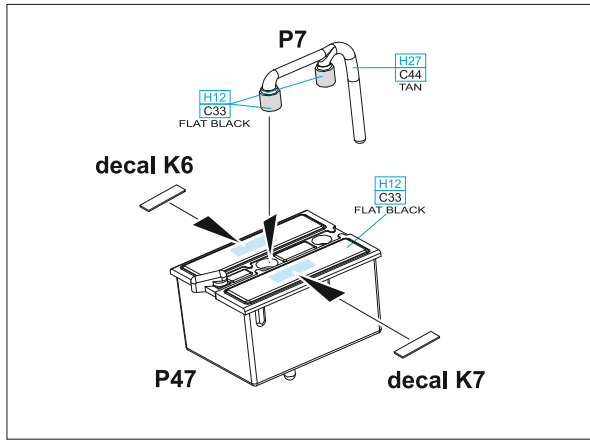

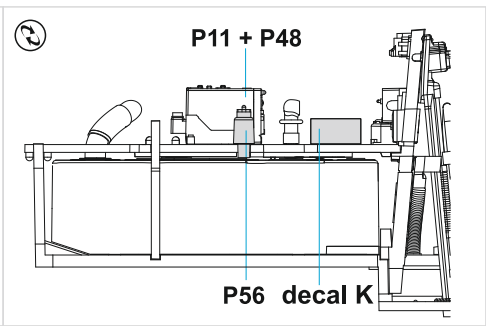
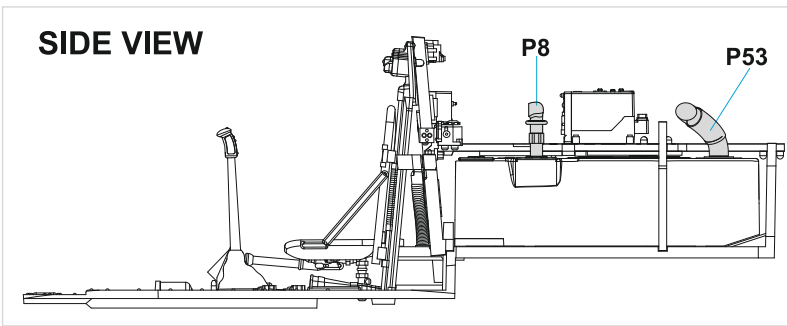
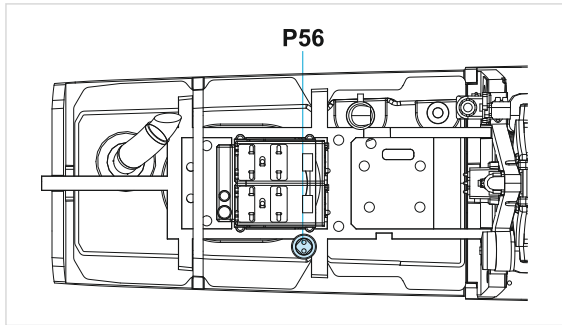
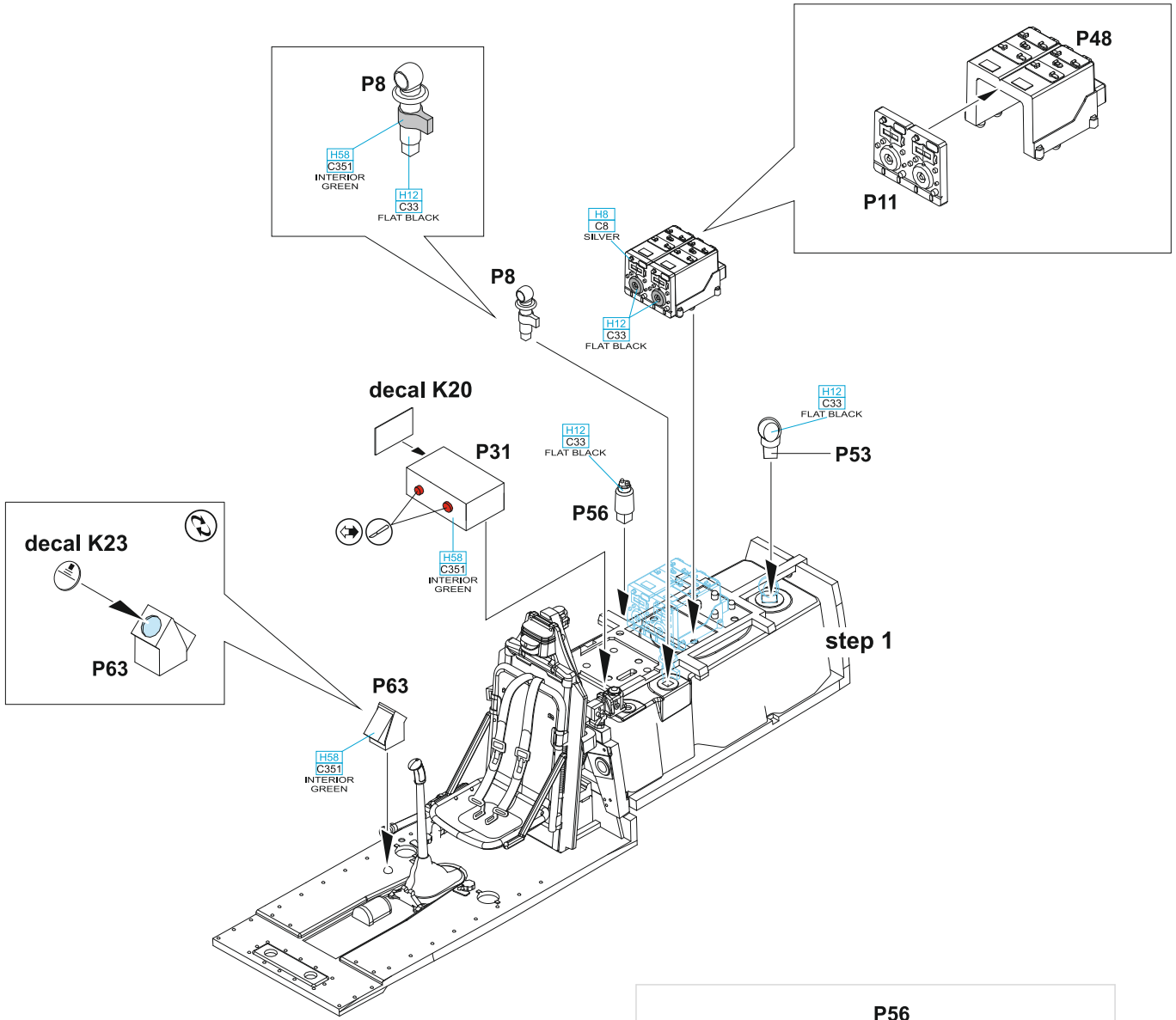

**B** MARKINGS **A, B, C**

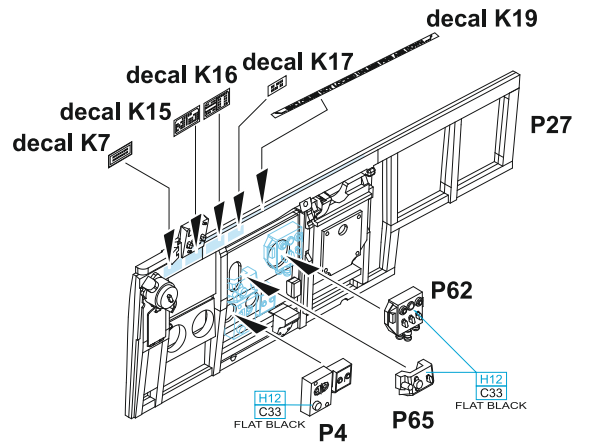
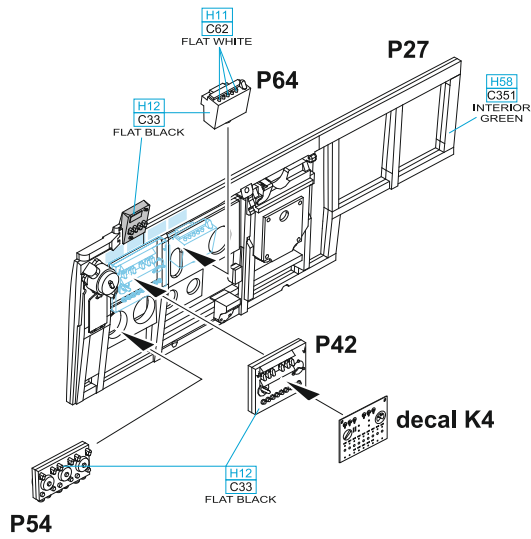

**MARKING D**

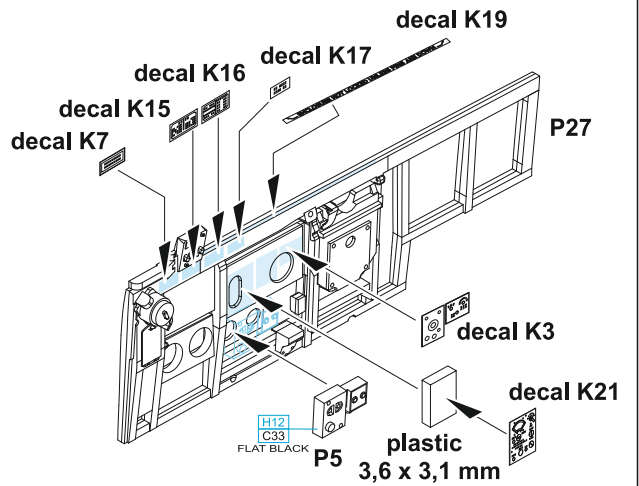
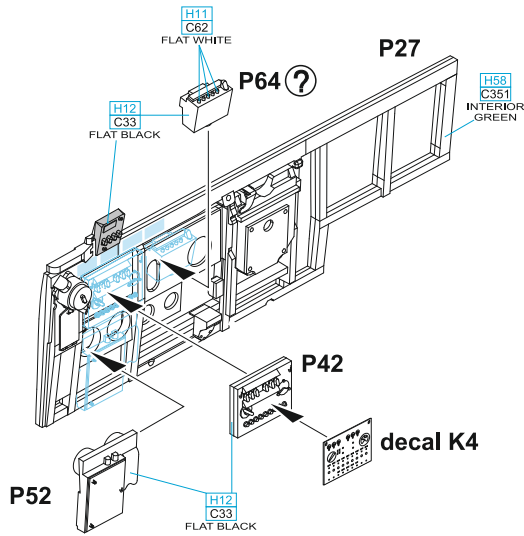

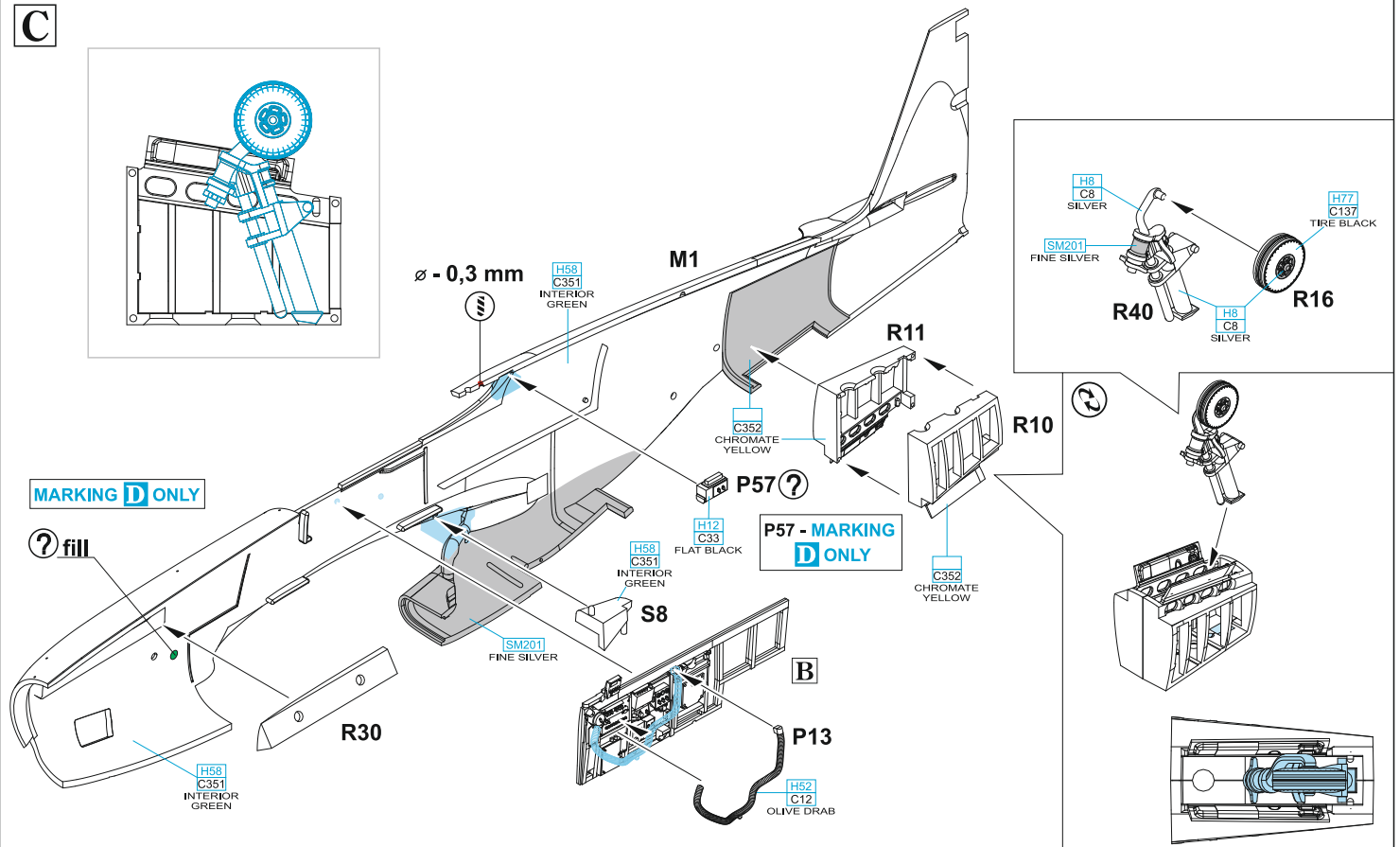
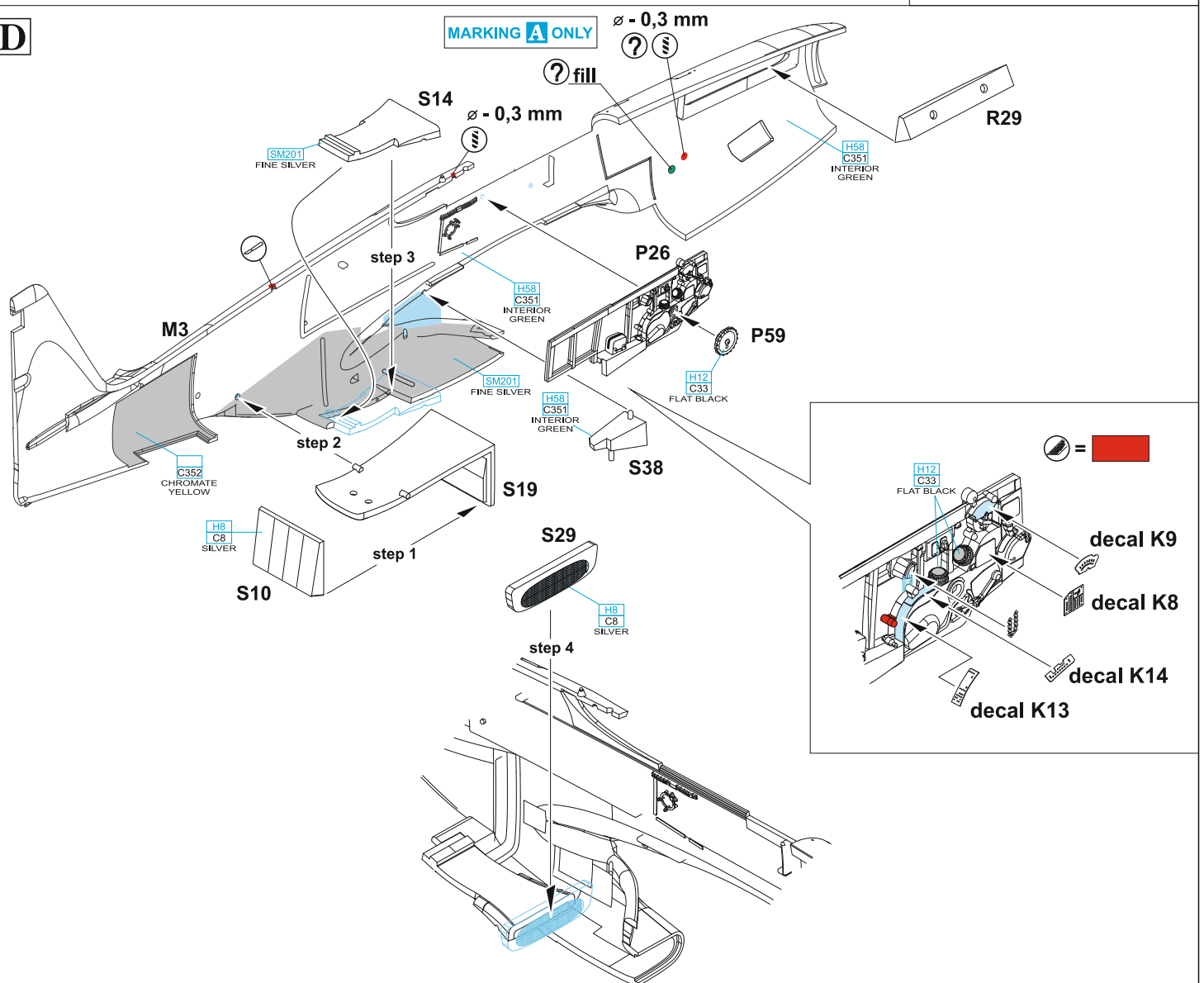
**C****D**

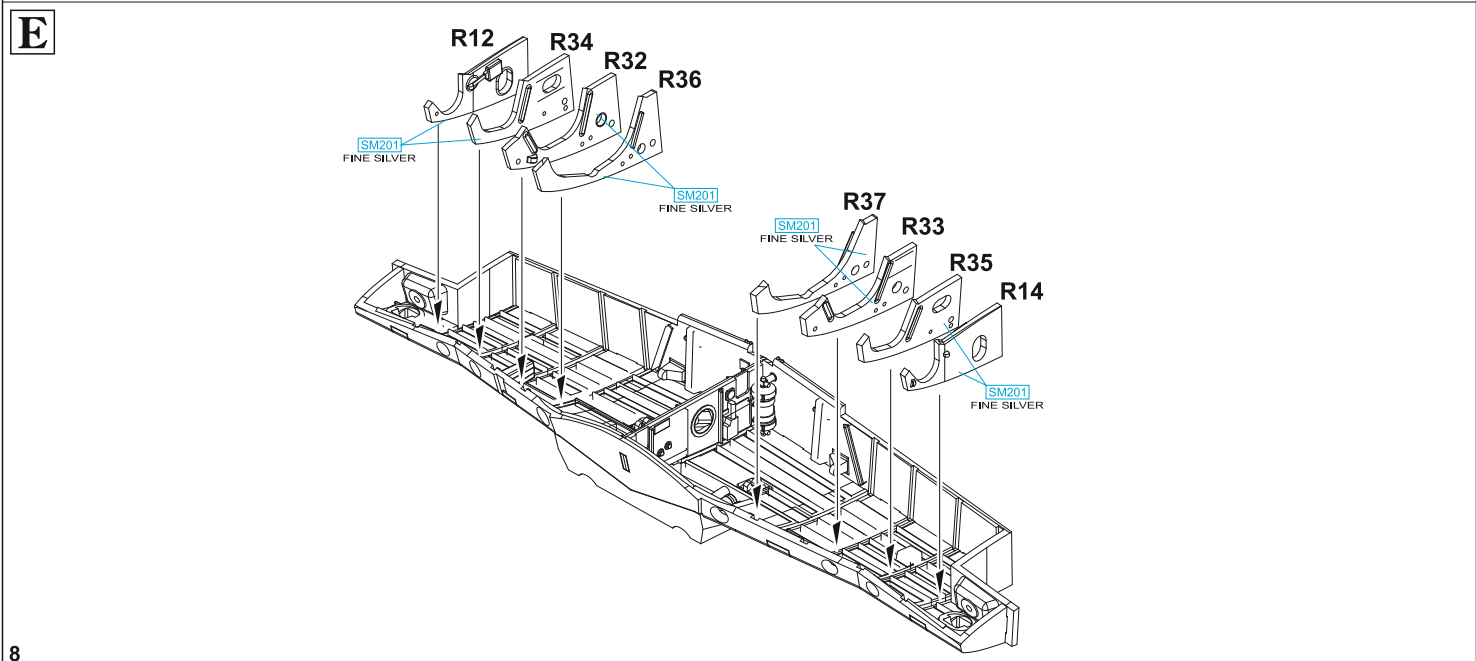
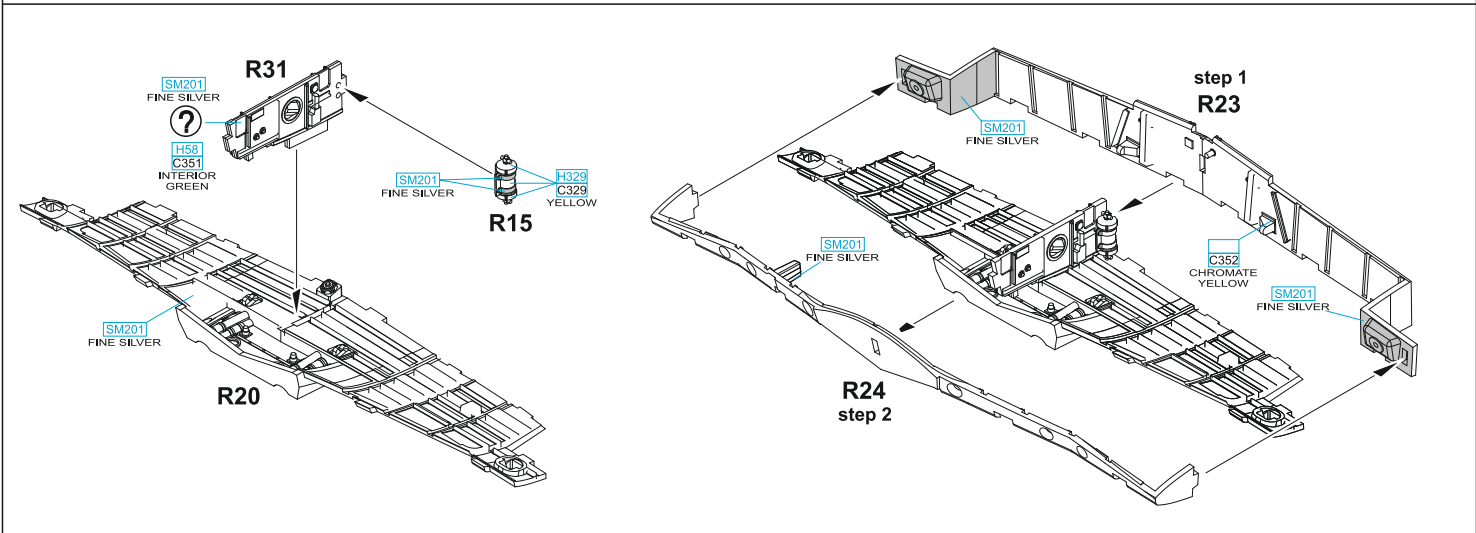
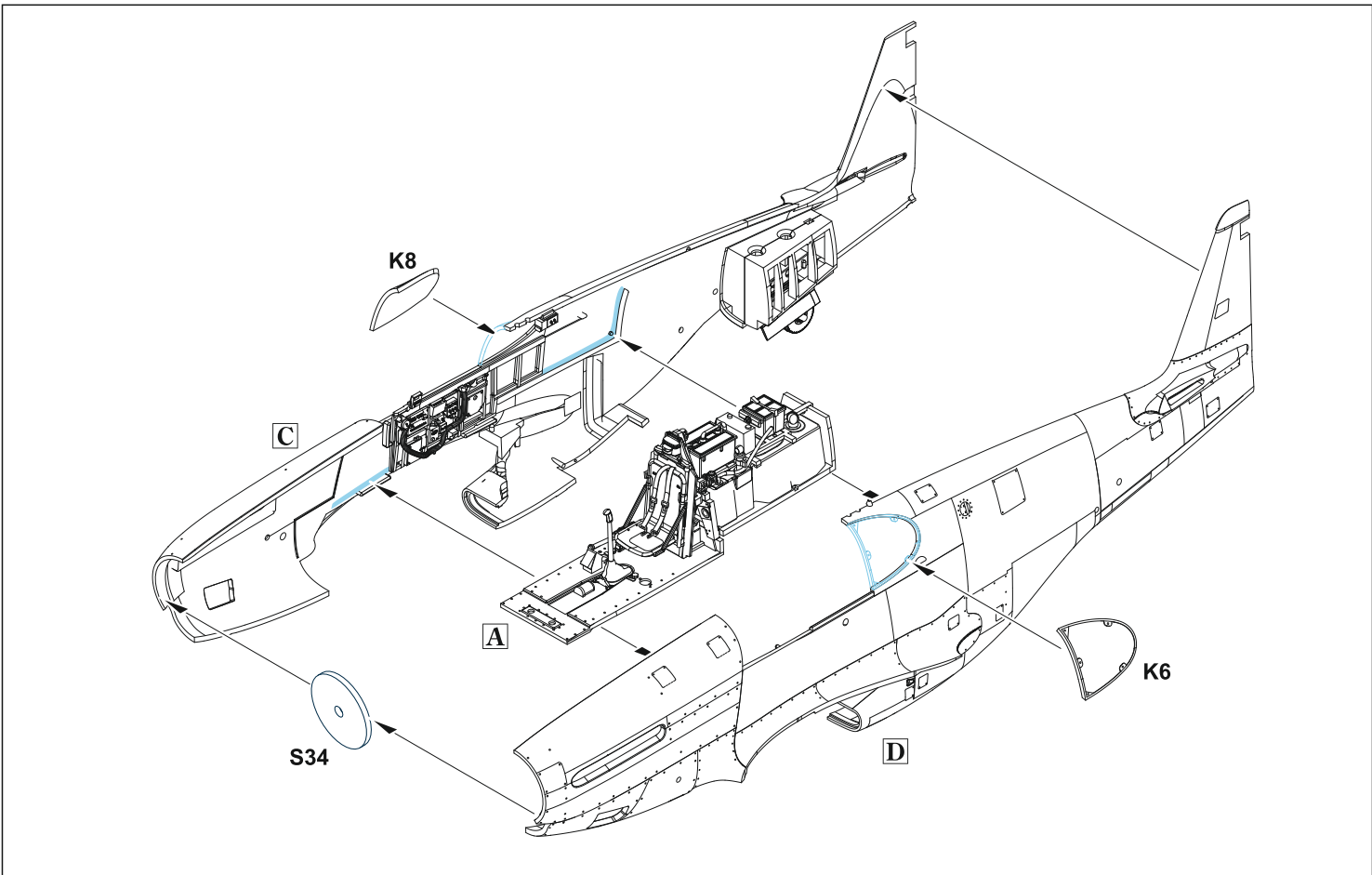

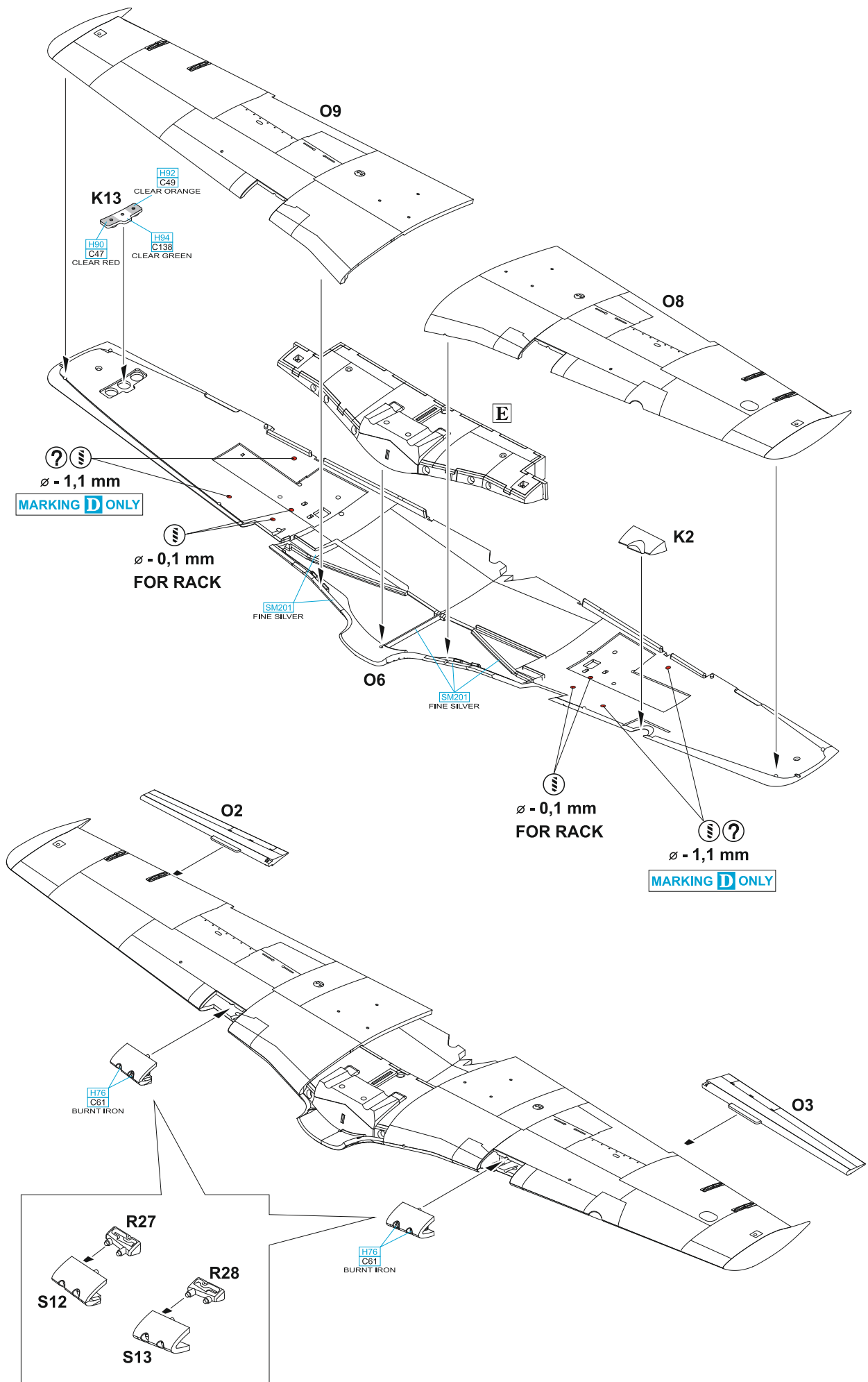

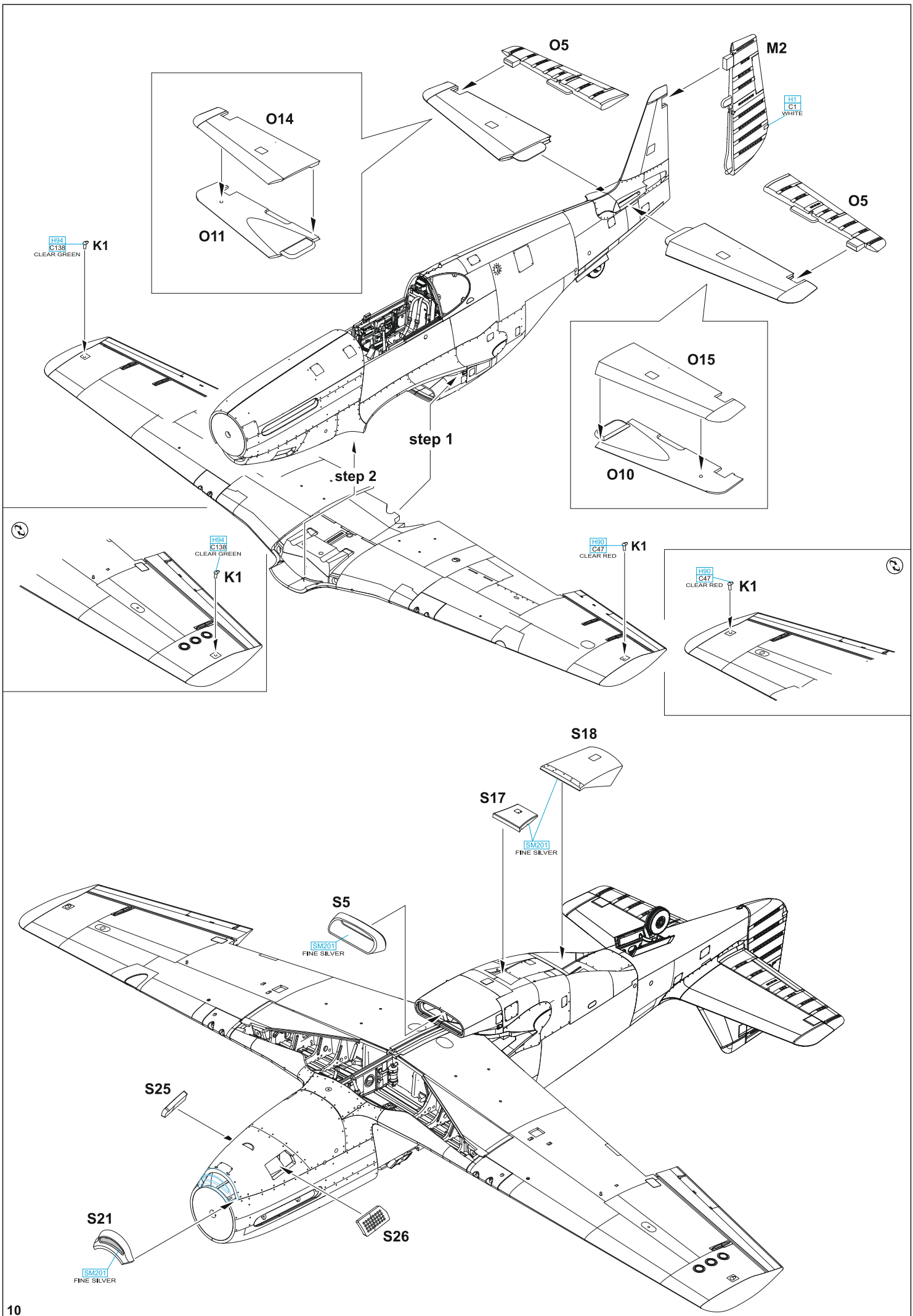

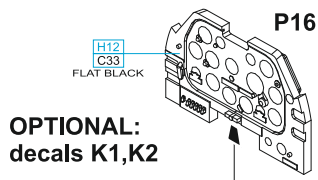

OPTIONAL:  
decals K1,K2

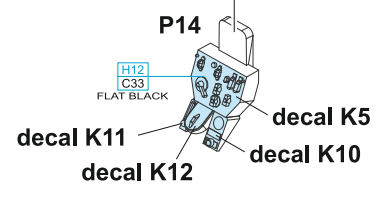

decal K2 - MARKINGS A, C  
decal K1 - MARKINGS B, D

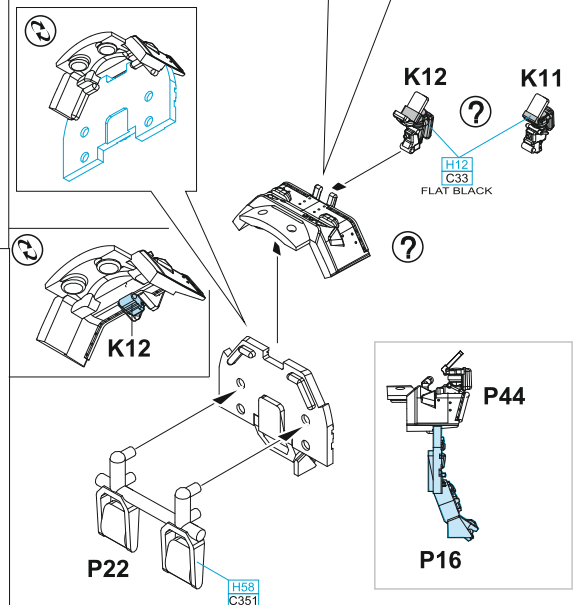
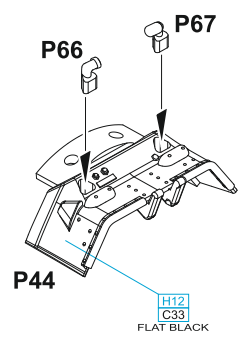
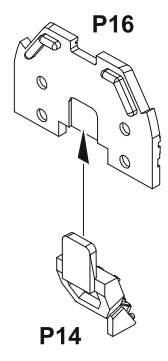

K11 - MARKINGS A, B  
K12 - MARKINGS D, C

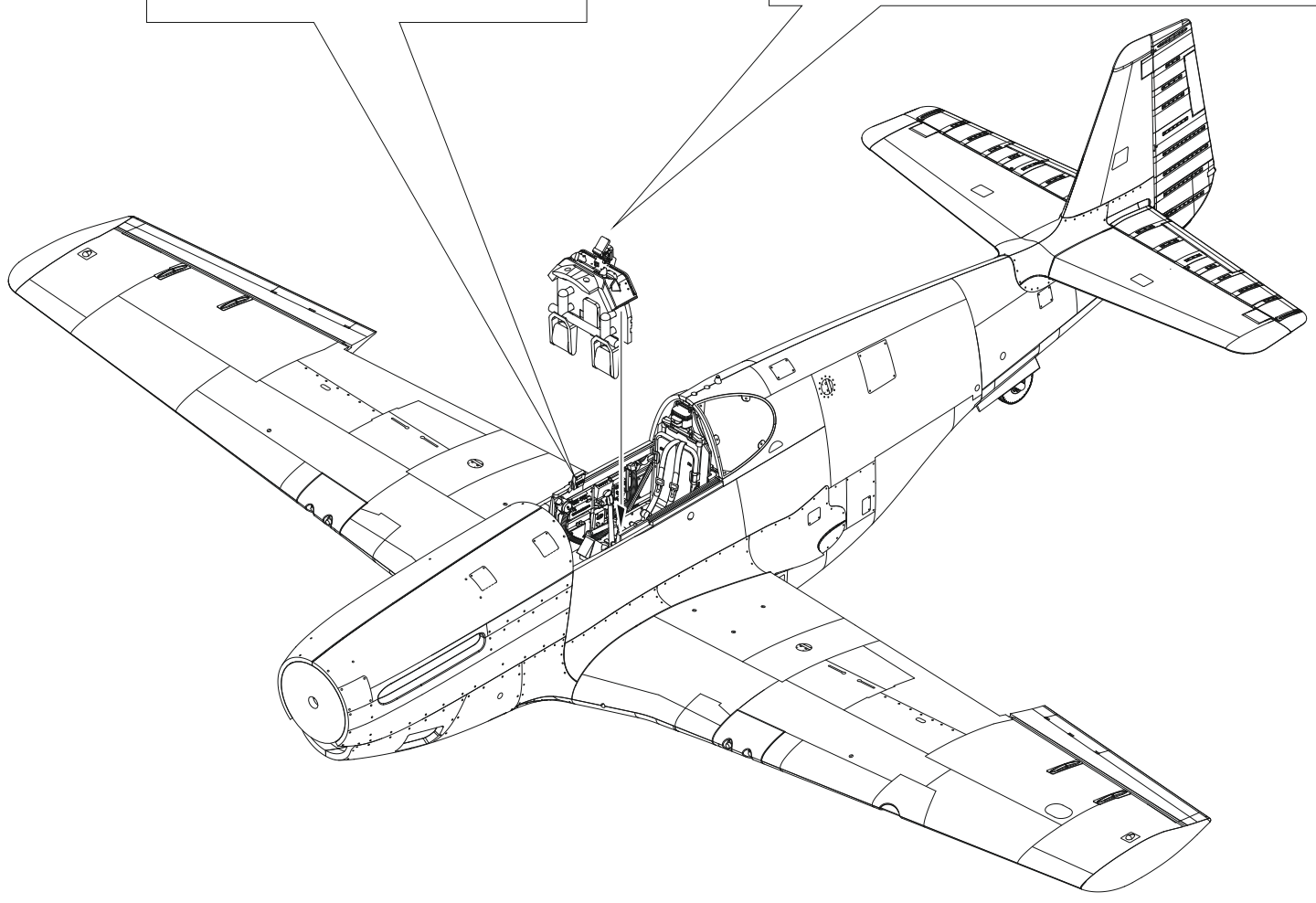
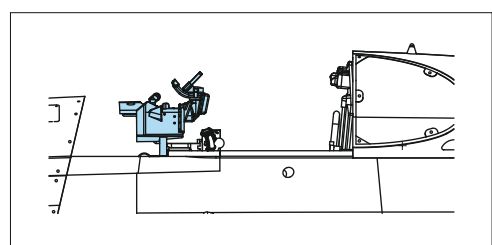

step 1 -  
R25, R26

step 2 -  
R38, R39

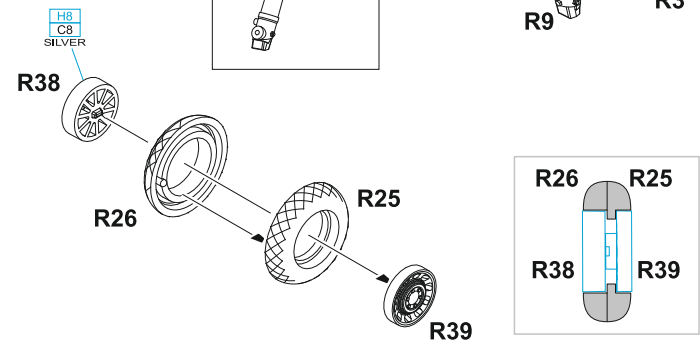

step 1 -  
R25, R26

step 2 -  
R38, R39

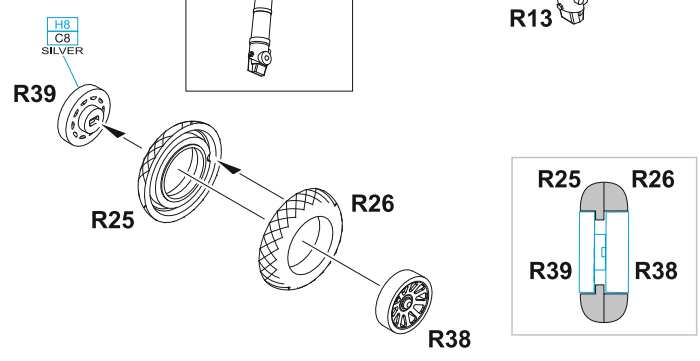

F

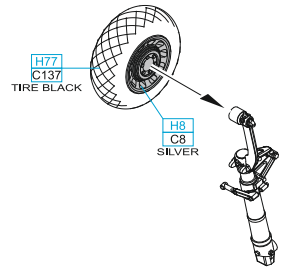

G

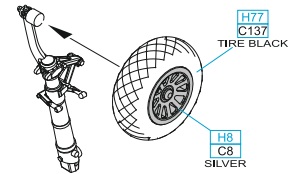

H

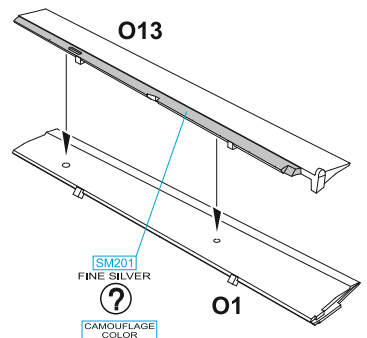

I

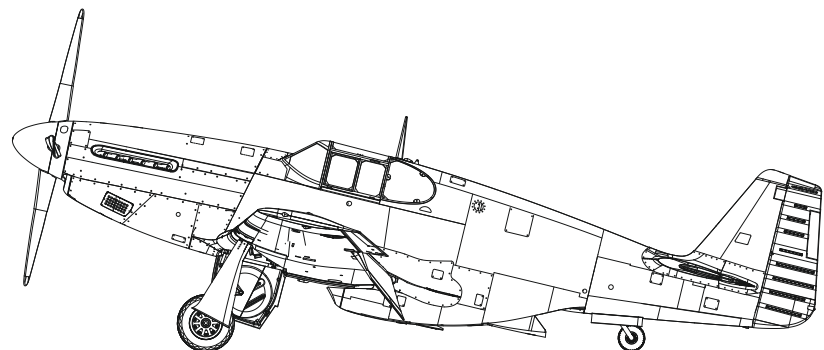
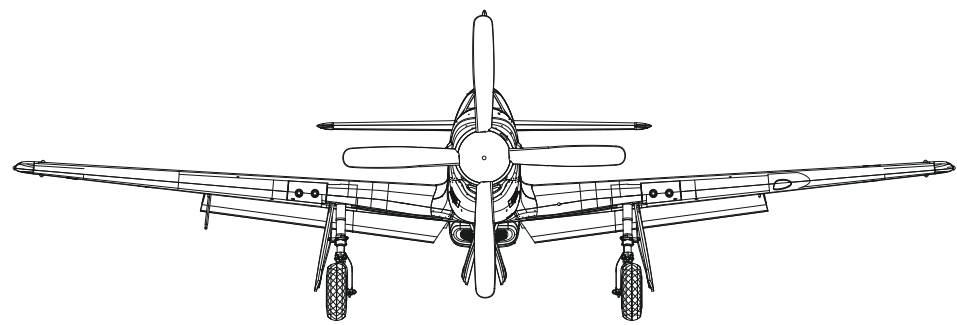
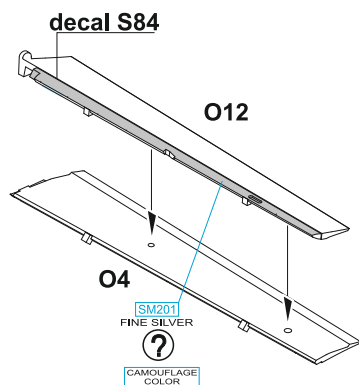

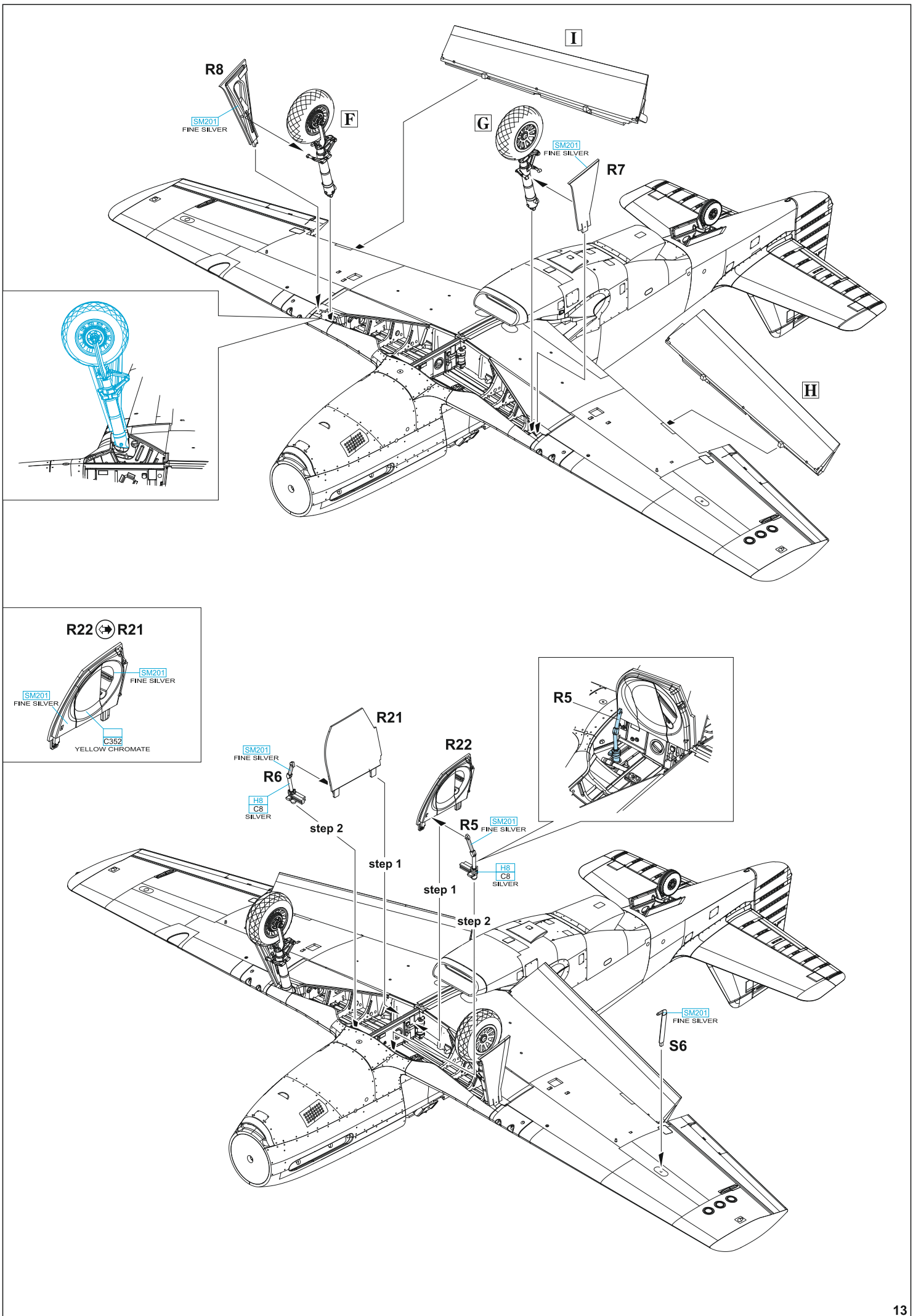

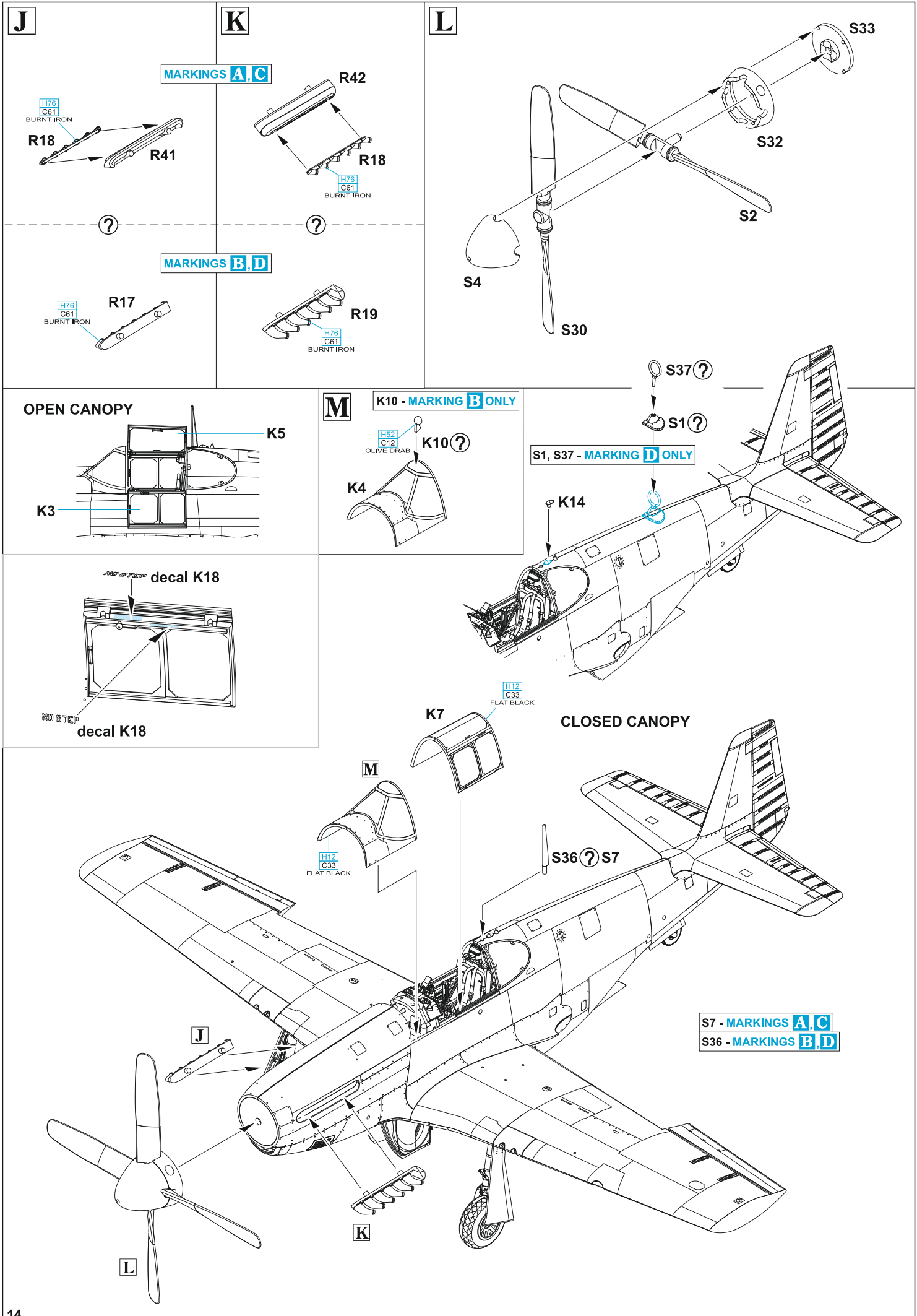

**J**

**K**

**L**

MARKINGS **A,C**

MARKINGS **B,D**

**M** K10 - MARKING **B** ONLY

S1, S37 - MARKING **D** ONLY

OPEN CANOPY

CLOSED CANOPY

S7 - MARKINGS **A,C**  
S36 - MARKINGS **B,D**

**N** 2 pcs.

?

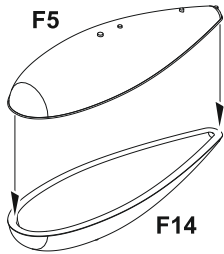

**O** 2 pcs.

?

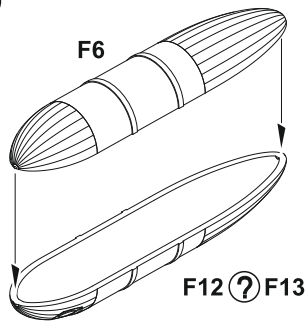

**P** MARKING D ONLY

?

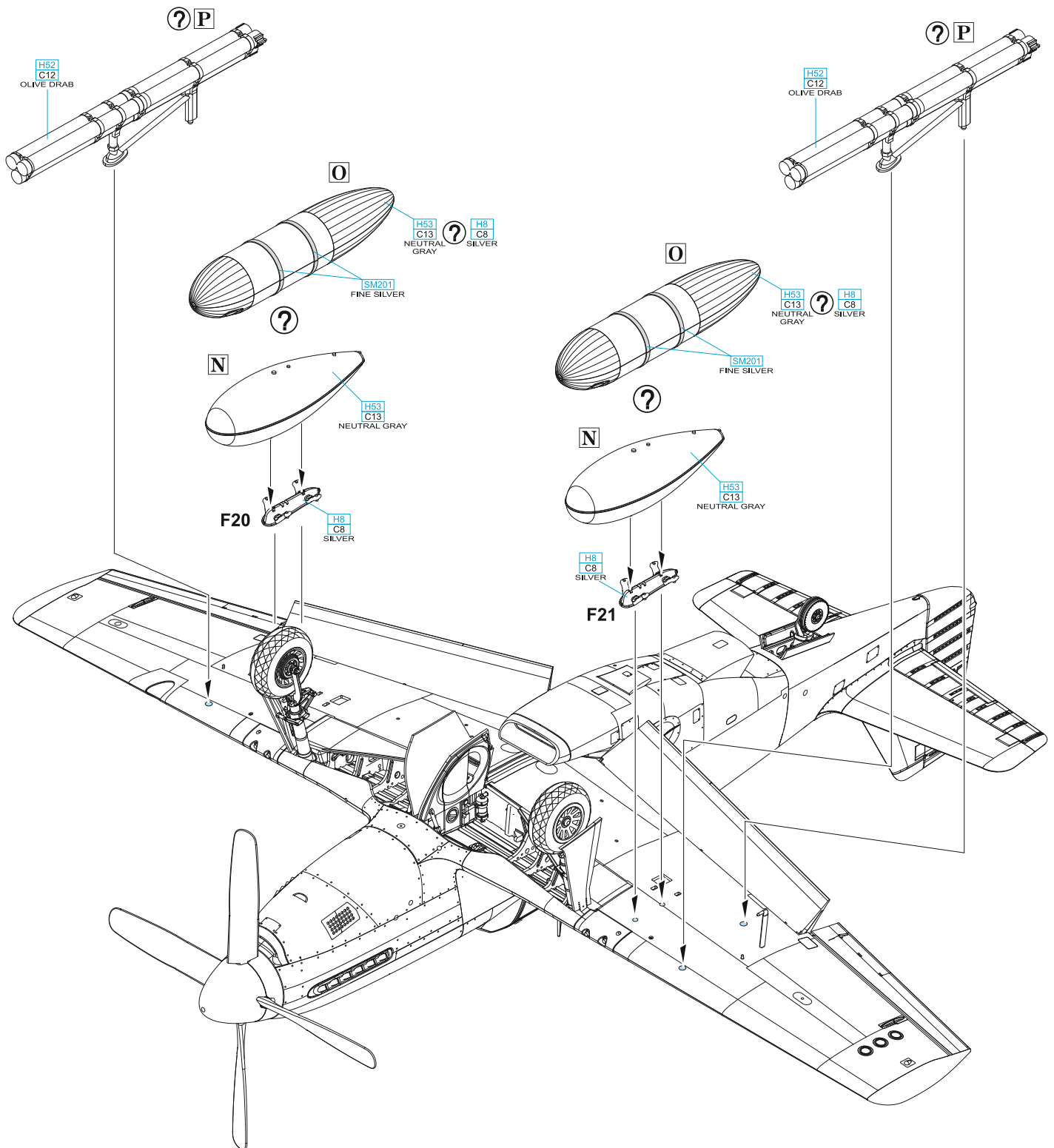
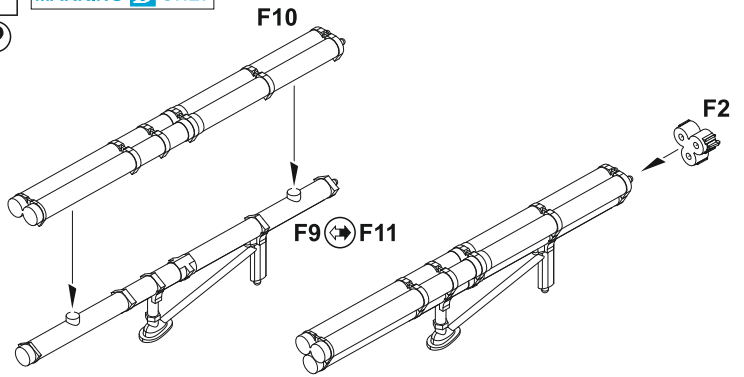

**A** P-51B-5-NA, s/n 43-6315, Lt. Col. James Howard, CO of 354<sup>th</sup> FG, 9<sup>th</sup> AF, Lashenden, United Kingdom, April 1944

The nickname Ding Hao was a Chinese expression for good luck that Jim Howard brought to Europe from his service in the Far East, where he flew with the AVG. The number of kill marks on his aircraft is misleading, as Howard did not actually down six Japanese aircraft during his service with the Flying Tigers in 1941-1942. The official number of kills with the AVG was two plus one shared, to which he added four enemy aircraft destroyed on the ground. On January 11, 1944, he single-handedly faced a group of about 30 Luftwaffe fighters while protecting a group of bombers. During the action, he shot down four aircraft and damaged several others and in the following days he added two more victories. Due to the pressure from the USAAF propaganda department, he had allowed S/Sgt Marcus Hanson to paint six "rising suns" on his aircraft in addition to six swastikas, even though this did not correspond to his combat achievements with the AVG. Howard's Mustang later became one of the first aircraft of this type in the 354<sup>th</sup> FG to be equipped with a Malcolm hood canopy, which was highly valued by P-51B pilots.

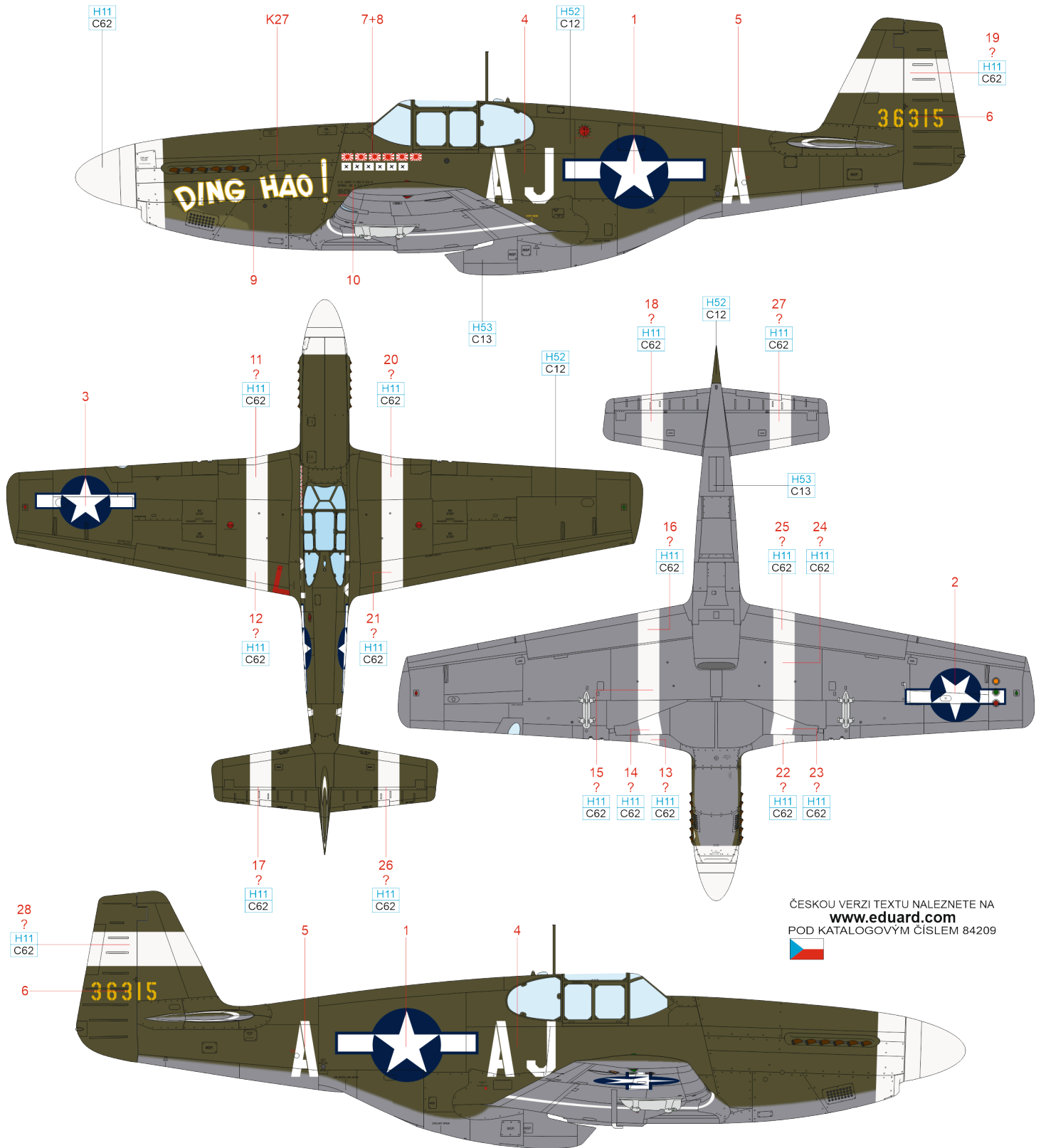

ČESKOU VERZI TEXTU NALEZNETE NA  
[www.eduard.com](http://www.eduard.com)  
 POD KATALOGOVÝM ČÍSLEM 84209



OLIVE DRAB H52 NEUTRAL GRAY H53 FLAT WHITE H11 C62

**eduard**

**B** P-51B-5-NA, s/n 42-106471, Lt. Col. John C. Meyer, CO of 487<sup>th</sup> FS, 352<sup>th</sup> FG, 8<sup>th</sup> AF, Bodney, United Kingdom, May 1944

The appearance of the name Lambie on Meyer's Mustang went through several phases. Initially, it was painted black but when the Mustangs of the 352<sup>nd</sup> FG were given their famous blue nose paint in the spring of 1944, the inscription was first changed to yellow and then was given red shading on the black and yellow lettering as portrayed in this scheme. John Meyer shot down a total of five aircraft flying this P-51B between April 10 and May 12, 1944, plus one in cooperation with others. He added six more aircraft destroyed on the ground. In total, Meyer achieved 24 victories during his wartime career and destroyed another 13 aircraft on the ground. The Lambie II was destroyed on June 7, 1944, when Lt. Clifford Garney collapsed in its cockpit near Bodney while returning from a mission to France and died.

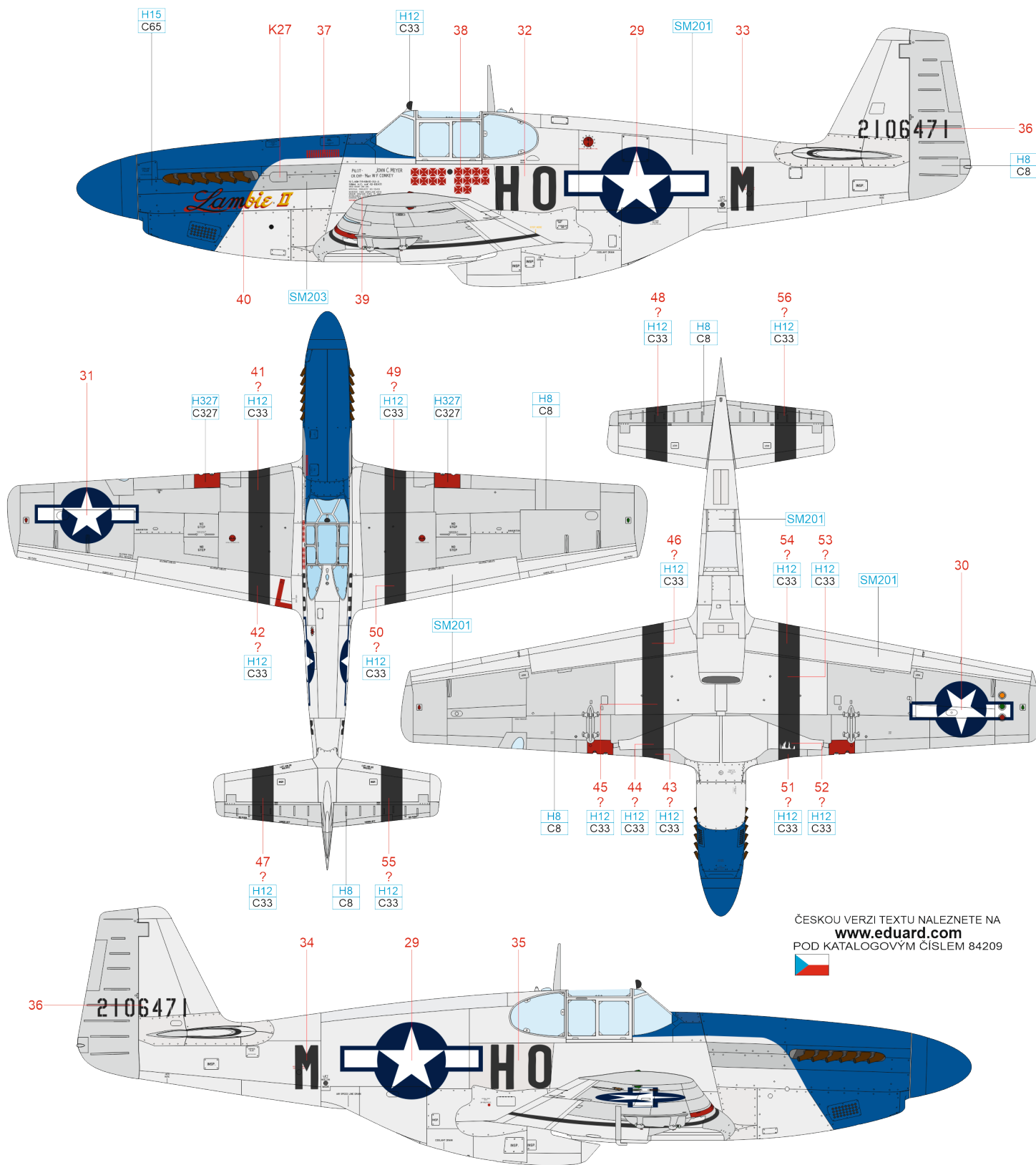

ČESKOU VERZI TEXTU NALEZNETE NA  
[www.eduard.com](http://www.eduard.com)  
 POD KATALOGOVÝM ČÍSLEM 84209



FLAT BLACK	H12 C33	RED	H327 C327	SILVER	H8 C8	SUPER FINE SILVER 2	SM201	SUPER IRON 2	SM203
------------	------------	-----	--------------	--------	----------	---------------------	-------	--------------	-------

**C** P-51B-10-NA, s/ n 43-7099, Maj. Alvan C. Gillem II, CO of 307<sup>th</sup> FS, 31<sup>st</sup> FG, 15<sup>th</sup> AF, Nettuno, Italy, February 1944

Alvan Cullom Gillem II, a native of Arizona, served with the 307<sup>th</sup> Fighter Squadron on Spitfire Mk.VIII aircraft and later on North American P-51 Mustangs. He took command of the 307<sup>th</sup> FS in February 1944. He participated in many missions over Italy, the Balkans, Austria, and Romania. On May 2, 1944, he shot down a Macchi C.205 Veltro and two more aircraft of the same type on May 7, 1944. He also led escort and attack missions on strategic targets in Ploiești and Anzi and received the Distinguished Flying Cross (DFC) for his outstanding performance in aerial combat. After the war, he stayed in service and retired in 1973 with the rank of General. The Gillem family boasted a long military tradition dating back to the Civil War and Alvan became the second general in three consecutive generations of Gillems. Not only he, but also his father and then his son achieved the rank of general. His father served in the US Army, his son in the USAF.

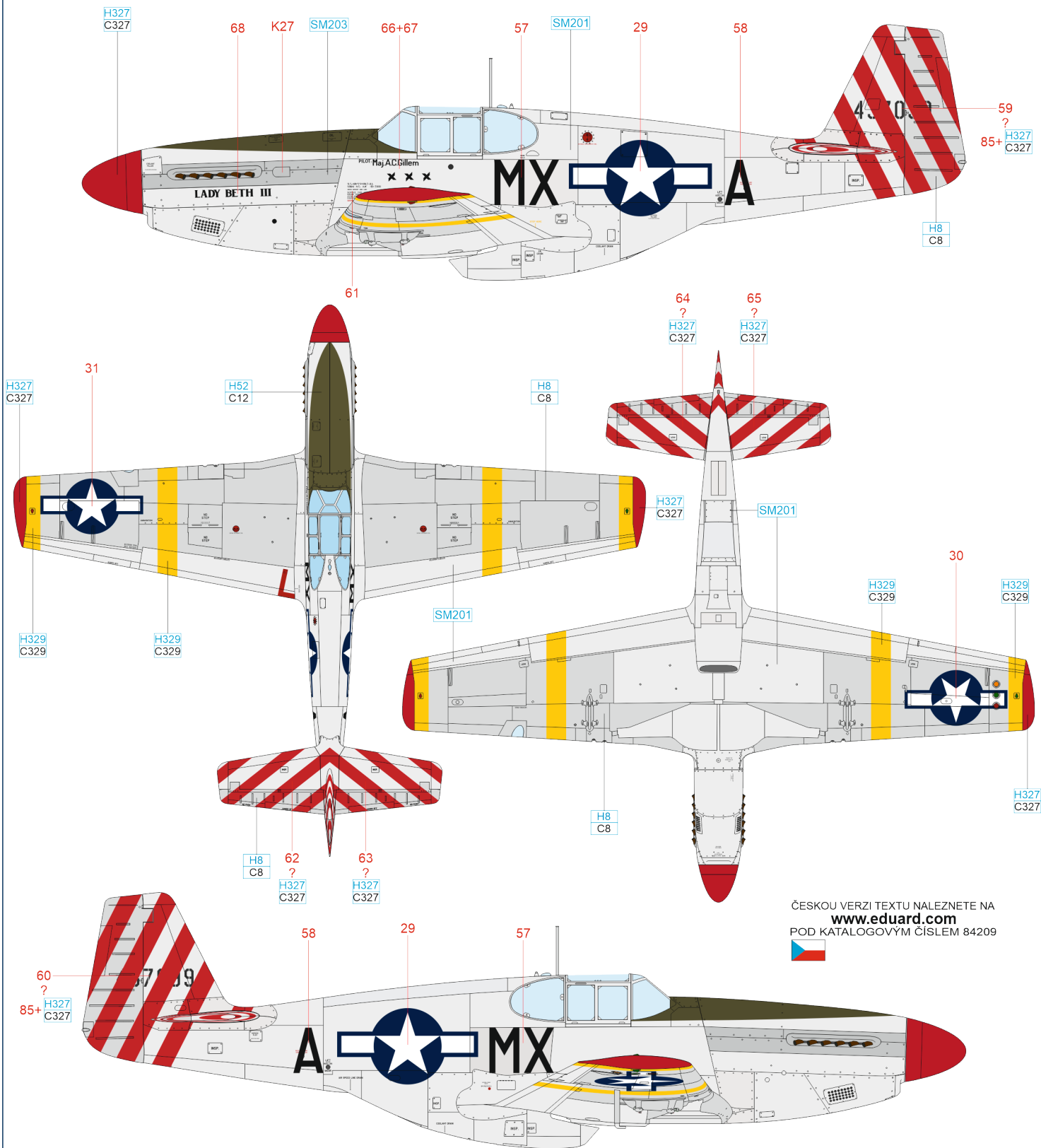

ČESKOU VERZI TEXTU NALEZNETE NA  
**www.eduard.com**  
 POD KATALOGOVÝM ČÍSLEM 84209



- YELLOW H329 C329
- OLIVE DRAB H52 C12
- RED H327 C327
- SILVER H8 C8
- SUPER FINE SILVER 2 SM201
- SUPER IRON 2 SM203

# D P-51B-15-NA, s/n 42-106971, Capt. Benjamin H. Ashmore, 26<sup>th</sup> FS, 51<sup>st</sup> FG, Nanning, China, autumn 1944

Benjamin Howard Ashmore fought in the ranks of the 26<sup>th</sup> FS in 1943/44. He used two P-40N Warhawks for combat flights, which he exchanged for a P-51B Mustang in the summer of 1944. All his aircraft bore the name Anvil Chorus and the emblem of a bull on a map of Texas on the sides of the fuselage under the cockpit. On September 10, 1944, Ashmore, flying a P-51B, led a trio of Warhawks from the 25<sup>th</sup> FS on patrol north of Longling. There, he engaged in aerial combat with a formation of four Ki-48 Lily light bombers protected by a dozen Ki-43 Oscar fighters. Ashmore first attacked one of the bombers and shot it down. He then engaged the accompanying Oscars and damaged two with his fire. On December 18, 1943, he added one Zero to his tally. Altogether he flew 78 combat missions during the war. The Mustang named Anvil Chorus III was lost on January 14, 1945. At that time, it was serving with the 3<sup>rd</sup> FG CACW and bore the name Big Blue Eyes. Lt. Van N. Moad Jr. was killed in its cockpit.

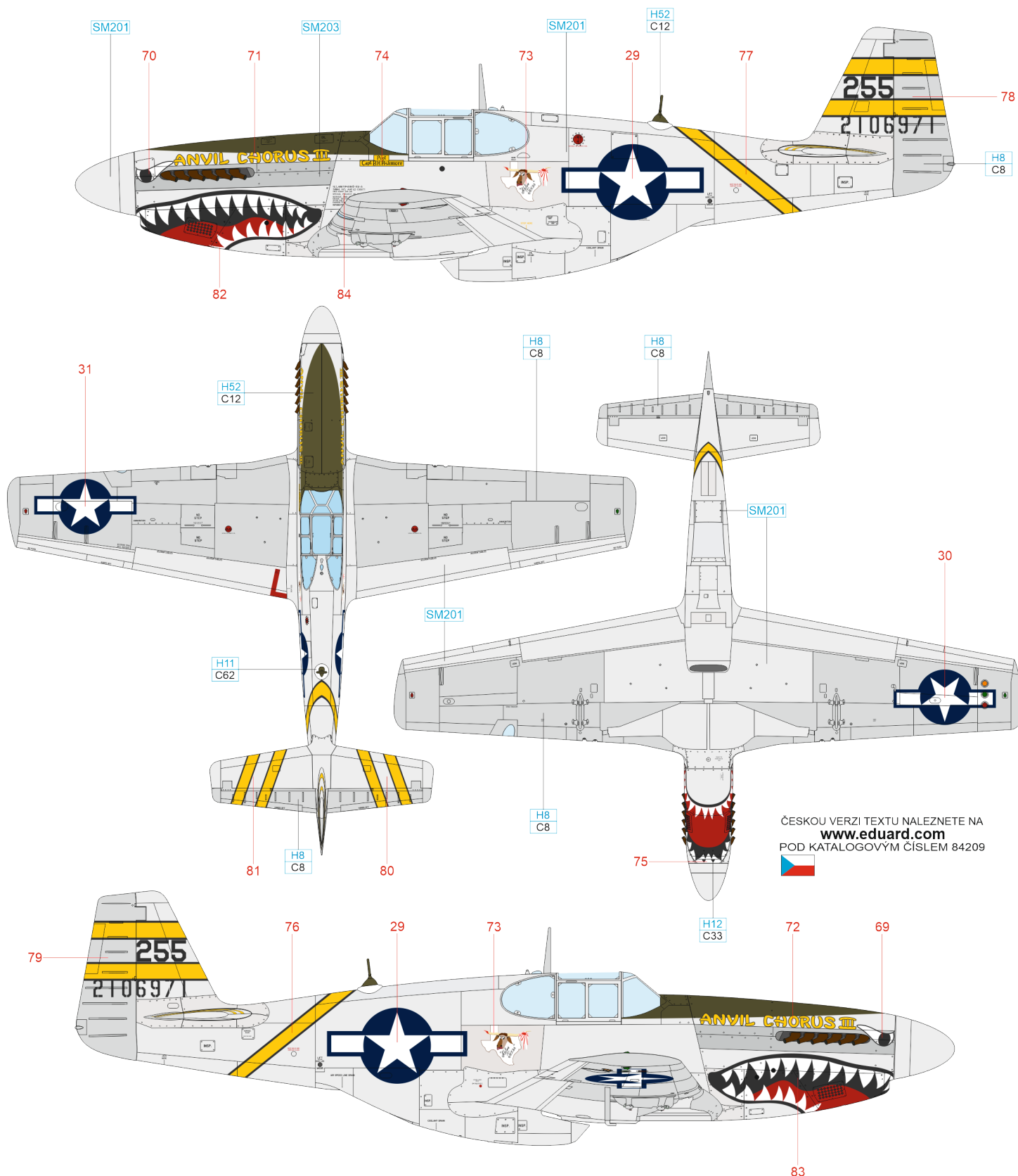

ČESKOU VERZI TEXTU NALEZNETE NA  
[www.eduard.com](http://www.eduard.com)  
 POD KATALOGOVÝM ČÍSLEM 84209

FLAT BLACK	H12 C33	FLAT WHITE	H11 C62	SILVER	H8 C8	SUPER FINE SILVER 2	SM201	SUPER IRON 2	SM203
OLIVE DRAB	H52 C12								

