

## INTRO

The Royal Aircraft Factory SE.5a is credited with being one of the fastest and deadliest aircraft of World War I. But the story of this 'Spitfire of Great War', as it is sometimes referred to, is not so straightforward. The SE. 5 (Scout Experimental 5) was designed by Henry Folland, John Kenworthy and Frank Goodden as a fighter powered by the new 150hp V8 Hispano-Suiza 8Aa engine. As the rotary engines neared their limitations, in-line liquid cooled engines were supposed to be a more promising way to fly faster and higher. The first prototype of the new fighter made its maiden flight on November 22nd, 1916 and began a somewhat intricate journey from miserable testing to combat proven glory. The new engine was troublesome and the wing design of the plane had glitches. The first two prototypes were lost in crashes, with chief test pilot at the Royal Aircraft Factory and one of the aircraft's designers, Major F. W. Goodden, losing his life on January 28th, 1917. The problems were partly solved thanks to modifications adopted on the third prototype, thus creating the first production variant of the new fighter.

The SE.5 entered service with No.56 Sqn RFC, during April 1917. The squadron was home to several famous aces. One of them, Albert Ball, was instrumental in honing the SE.5 into a formidable airplane. The new fighter was received with mixed emotions because of its unusually high seat position, large windscreen and armament layout that was composed of fuselage mounted 0.303 Vickers and upper wing mounted 0.303 Lewis machine guns. Ball, together with his mechanic, worked during the nights to address smaller as well as bigger glitches of the new design and most of the changes they made to the design were adopted for all SE.5s at squadron level. The large windscreen was dispensed with and the pilots lowered their seats to a more normal position. But, they always prayed for good visibility from the cockpit. The changes made by No.56 Sqn were shortly adopted for production. The final few SE.5 aircraft built in July 1917 were fitted with a more powerful 200hp Hispano-Suiza 8Ab engine, effectively setting the SE.5a standard. Production of the SE.5 ended after only 77 examples being built. The SE.5a was then produced in high quantities by six manufacturers: Vickers (2164), Austin Motors (1650), Air Navigation and Engineering Company (560), Wolsley Motors Limited (431), Martinside (258) and Royal Aircraft Factory (200). The American Curtiss Aeroplane and Motor Company built one example, as production of some 1000 aircraft was considered there. The US Army Squadrons of the American Expeditionary Force were among those receiving the SE.5a, and the Curtiss supplies would equip them. But the armistice ended this plan.

The SE.5a is frequently compared to another famous WWI fighter, the Sopwith Camel, the last formidable British fighter with a rotary engine. Because of the different engine construction philosophy, the two fighters were very different aircraft. The Camel was highly maneuverable thanks to the centre of gravity pushed very far forward and also because of the sheer inertia of the rotating engine, which made it very fast in a right turn. But the Camel was an unforgiving airplane, dangerous to less experienced pilots. The SE.5a, although very fast, was to the contrary a very stable and forgiving fighter. It was not as agile as the Camel, but still agile enough. And above 10,000 ft it was clearly superior not only to the Camel, but also to most enemy aircraft. Furthermore, the armament of one fixed, fuselage mounted Vickers machine gun, supplemented by a Lewis machine gun affixed to the top of the upper wing made it possible for pilots to attack a high-flying enemy, sneaking up beneath it unobserved. Some pilots questioned this armament arrangement, with two fixed Vickers suggested as a better solution, but early problems with the Constantinesco synchronizing gear spoke against it. In the end, the SE.5 was the first fighter with two machine guns. The Camel entered the field later in 1917. For SE.5a pilots, it was quite easy to pull down the wing mounted Lewis machine gun for reloading, but changing the drum and pushing the weapon back into firing position was a different story. The slipstream could even ram the removed drum into the pilot's face. But, pilots learned how to get the best from the SE.5a, the best of them leading the way. Apart from the aforementioned Albert Ball, there was, for example, James McCudden, a former sapper and air mechanic, later an ace with 57 kills, who used his skills to optimise the engine of his SE.5a for use in high level solo patrols against high-flying Rumpier observers. While 17,000 ft was the ceiling for the usual SE.5a, McCudden was capable of sorties of up to the 20,000 ft level. Another of the more famous men of the RFC, Edward C. Mannock, developed tactics which allowed extraction of the best of the SE.5a's qualities.

### Hisso and Viper

Problems with both supply and reliability of the 200hp Hispano-Suiza (nicknamed 'Hisso') engines troubled the SE.5a throughout its service career. As a result, there were a number of engine modifications installed in the SE.5a, both from the French supplier of the Hispano-Suiza, as well as from the British Wolsley firm, whose engines were usually further developments of Hispano-Suiza designs. With the earlier geared engines, the prop shaft was driven by a reduction gear and the propeller rotated counter clockwise (from the pilots perspective). The later direct drive engines had the propeller rotating clockwise. As Hispano Suiza supplied most of the early engines, the nickname 'Hisso' was used for all the planes with the geared engine, whether it came from Hispano-Suiza or Wolsley. For later production, the more reliable direct drive Wolsley Viper became the standard engine and aircraft so equipped were nicknamed 'Viper', again without distinction between suppliers. After the armistice a great sale of army surplus was held, and many planes were offered to the public, including the SE.5a. The price of one airworthy plane was 5 £, which translates to some 1,500 £ at today's values. Some retired pilots, who never flew the SE.5a during the war, brought one just to make one test flight, returning the plane with a discount. Such was the reputation of the SE.5a, enticing the pilots to try them, even if it did cost them a sizeable amount of money! Many of SE.5as were actually sold and were used in air races and also for 'Sky-Writing' purposes in advertising.

# PLASTIC PARTS

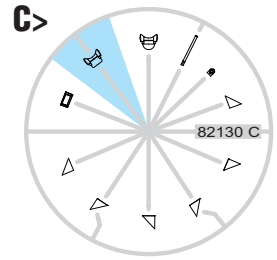
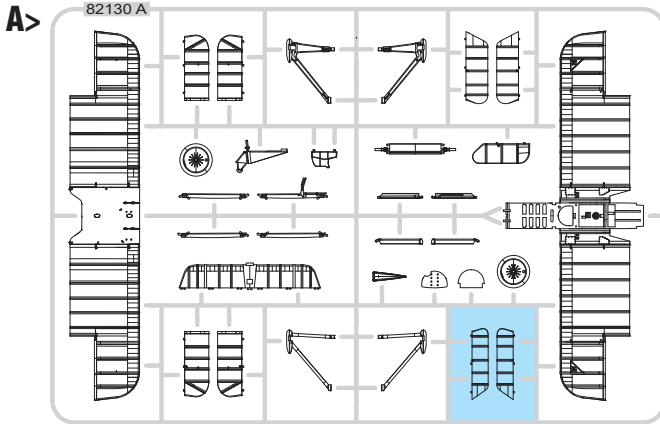

GUNZE		
H3	C3	RED
H11	C62	WHITE
H12	C33	FLAT BLACK
H33	C81	RUSSET
H37	C43	WOOD BROWN
H47	C41	RED BROWN
H51	C11	LIGHT GULL GRAY
H52	C12	OLIVE DRAB
H85	C45	SAIL COLOR
H309	C309	GREEN
Mr. METAL COLOR		
MC214 DARK IRON		
MC218 ALUMINIUM		
MC219 BRASS		

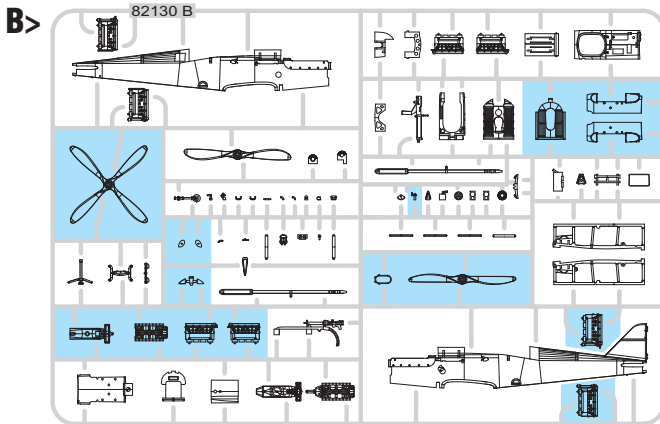

-Parts not for use. -Teile werden nicht verwendet. -Pièces à ne pas utiliser. -Tyto díly nepoužívejte při stavbě. - 使しない部品

## ATTENTION \* UPOZORNĚNÍ \* ACHTUNG \* ATTENTION

- (GB)** Carefully read instruction sheet before assembling. When you use glue or paint, do not use near open flame and use in well ventilated room. Keep out of reach of small children. Children must not be allowed to suck any part, or pull vinyl bag over the head.
- (CZ)** Před započatím stavby si pečlivě prostudujte stavební návod. Při používání barev a lepidel pracujte v dobře větrané místnosti. Lepidla ani barvy nepoužívejte v blízkosti otevřeného ohně. Model není určen malým dětem, mohlo by dojít k požití drobných dílů.
- (D)** Vor dem Zusammenbau die Bauanleitung gut durchlesen. Kleber und Farben nicht in der Nähe von offenem Feuer verwenden und für eine ausreichende Belüftung sorgen. Den Bausatz von kleinen Kindern fernhalten. Vermeiden Sie, dass Kinder Bauteile in den Mund nehmen oder sich Plastiktüten über den Kopf ziehen.
- (F)** lire soigneusement la fiche d'instructions avant d'assembler. Ne pas utiliser de colle ou de peinture à proximité d'une flamme nue, et aérer la pièce de temps en temps. Garder hors de portée des enfants en bas âge. Ne pas laisser les enfants mettre en bouche ou sucer les pièces, ou passer un sachet vinyl sur la tête.

## INSTRUCTION SIGNS \* INSTR. SYMBOLY \* INSTRUKTION SINNBILDEN \* SYMBOLES

- OPTIONAL VOLBA
- BEND OHNOUT
- OPEN HOLE VYVRTAT OTVOR
- SYMETRICAL ASSEMBLY SYMETRICKÁ MONTÁŽ
- REMOVE ODŘÍZNOUT
- REVERSE SIDE OTOČIT

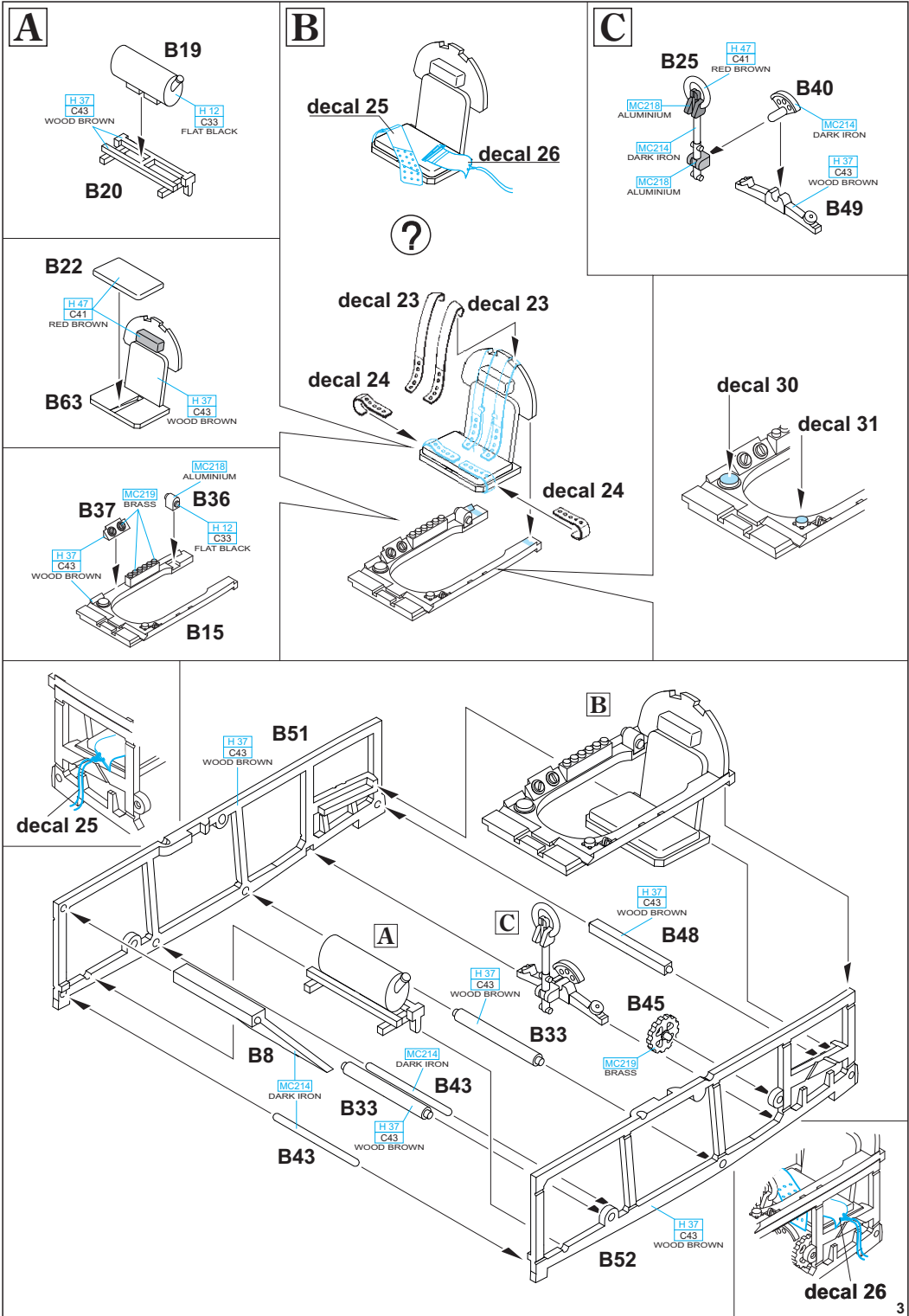

step 1

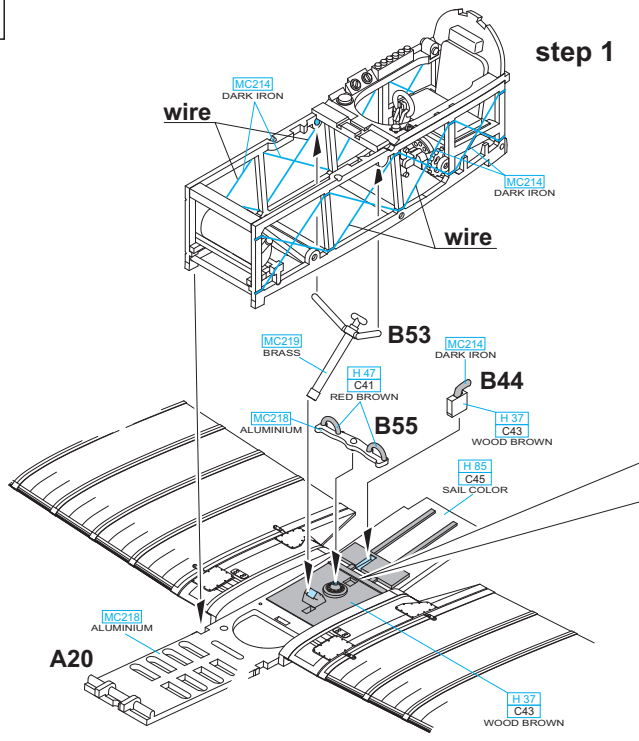

step 2

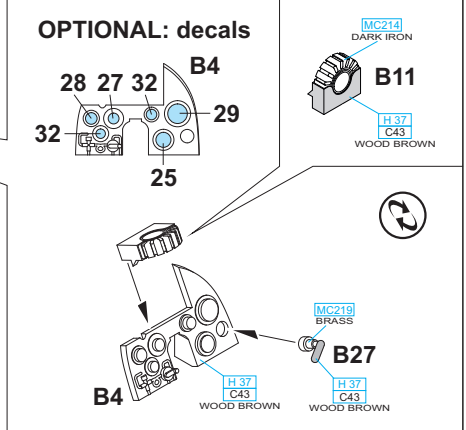
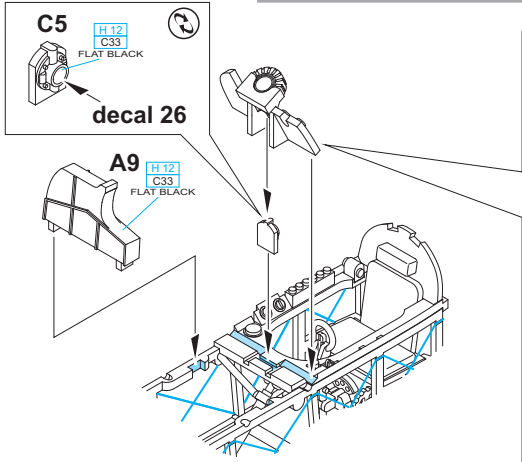
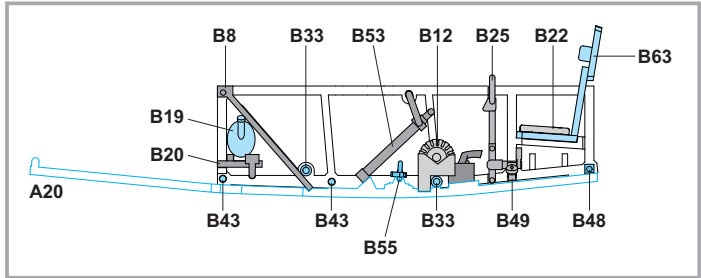
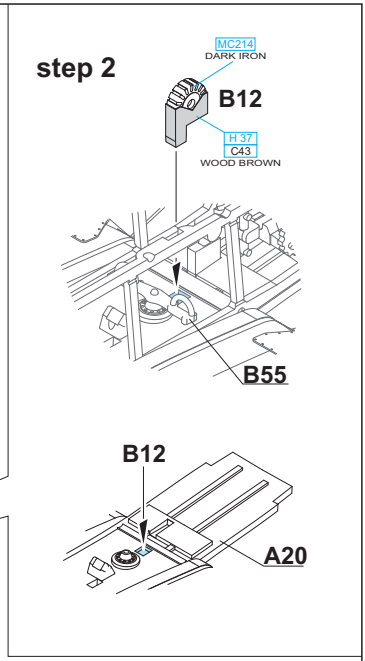

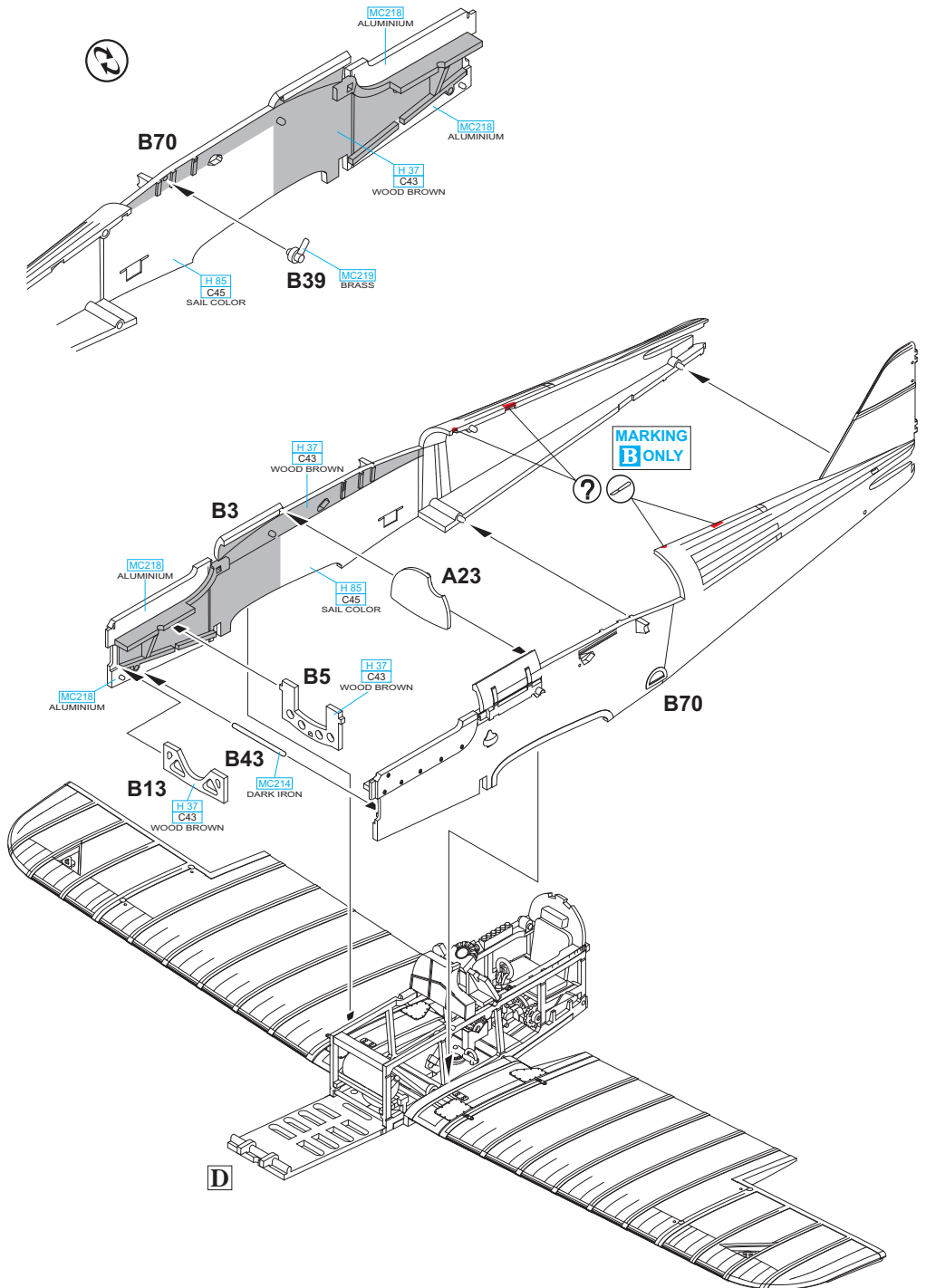

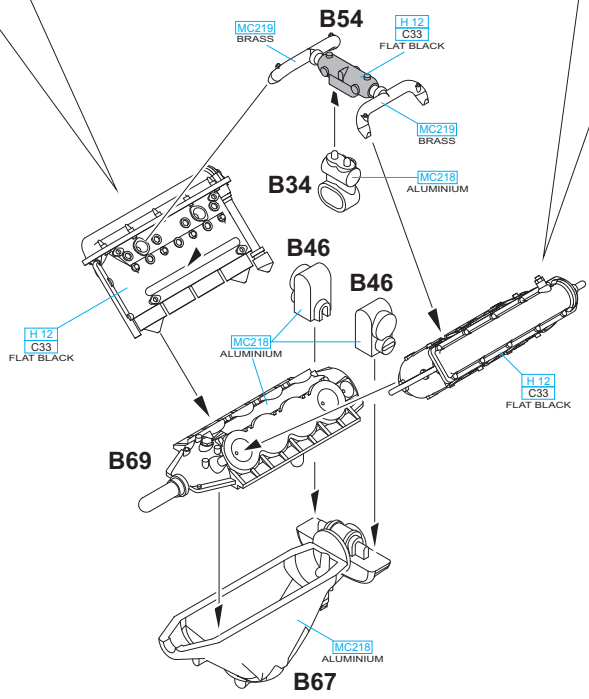
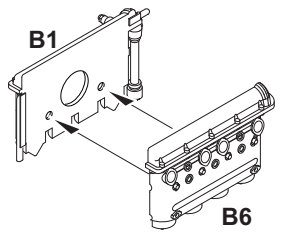
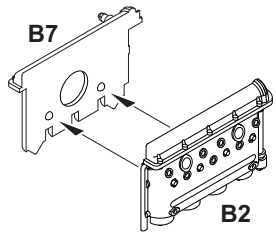
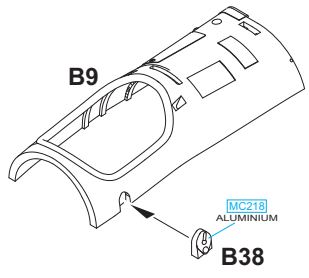
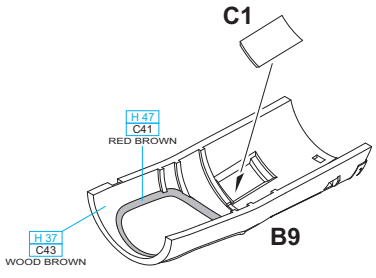
**E****F**

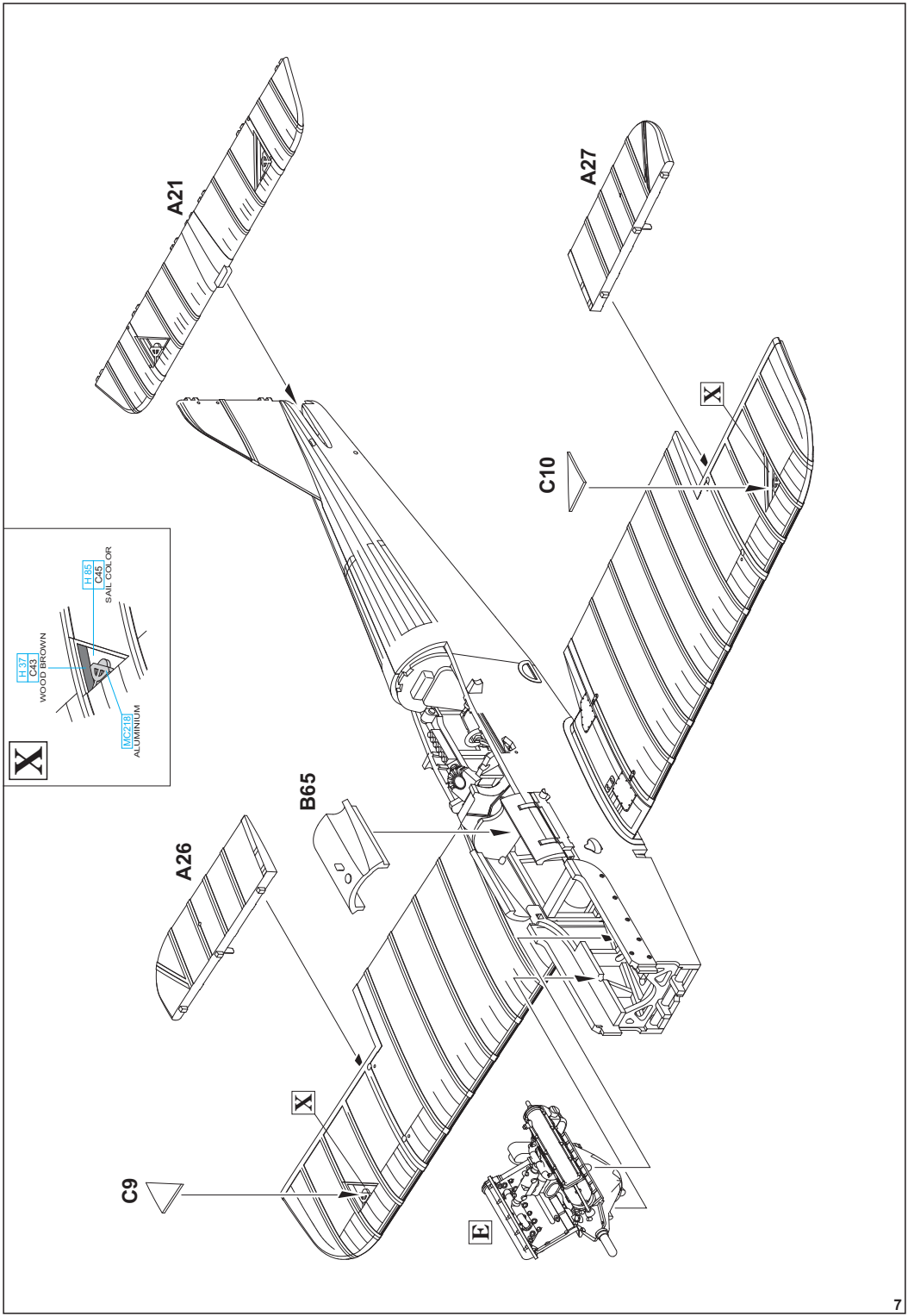

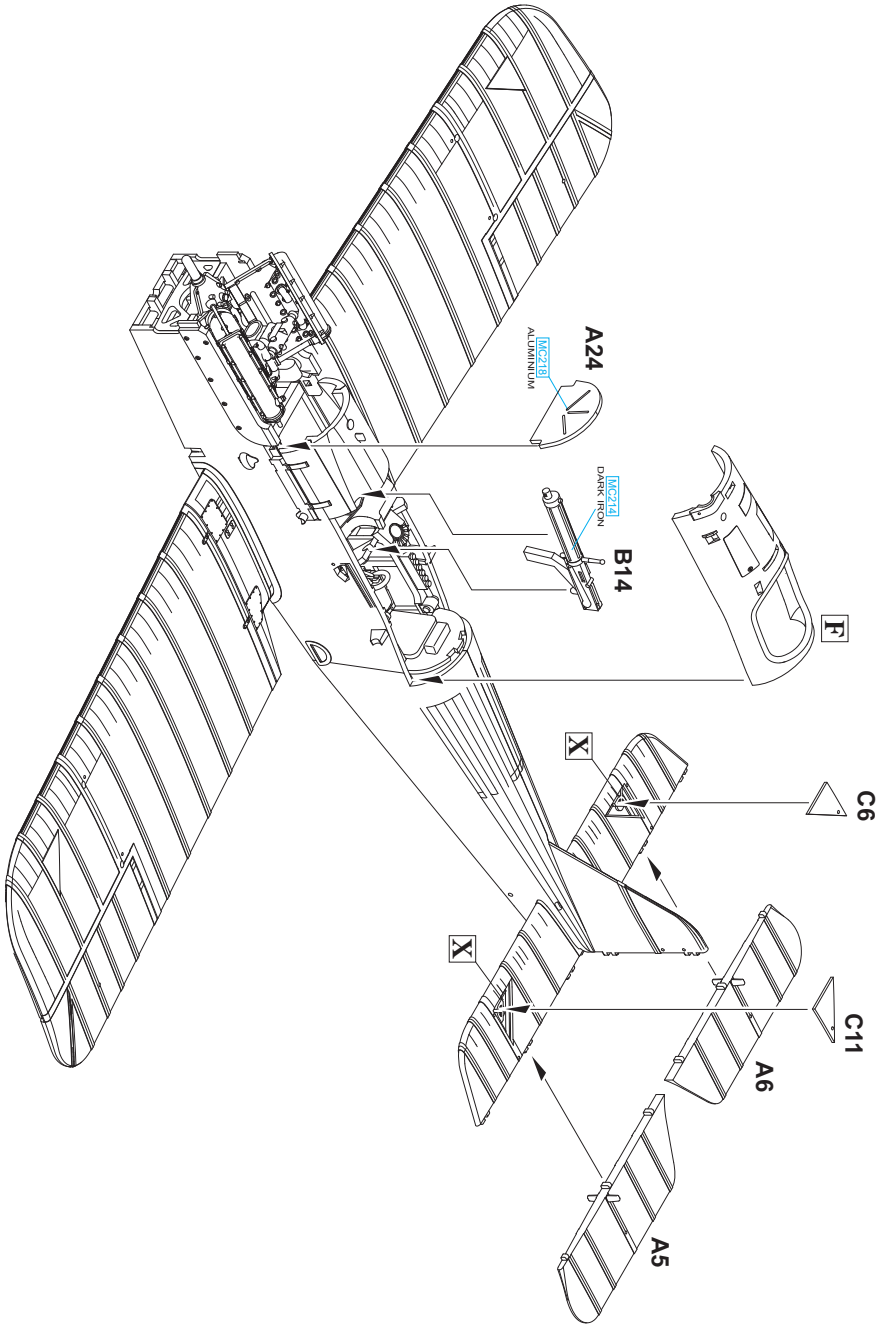

C2 - MARKING B  
C3 - MARKING A

C2

?

C3

B50

MC212  
MC213  
FLAT BLACK

C4

B42

B74 ?

B74 - MARKING B ONLY

B60

MC219  
BRASS

B17

MC215  
ALUMINIUM

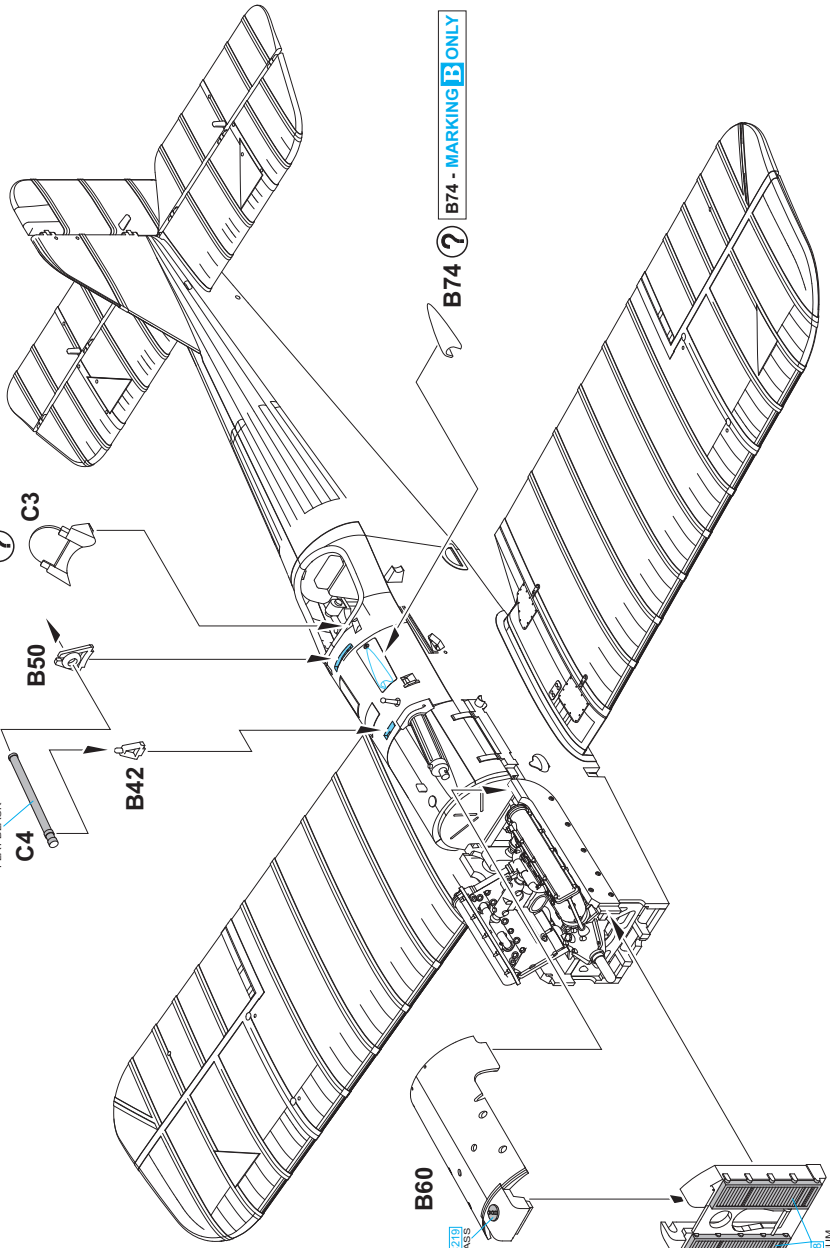

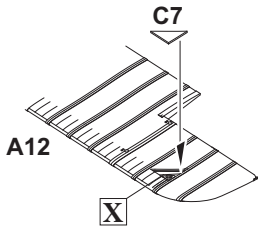
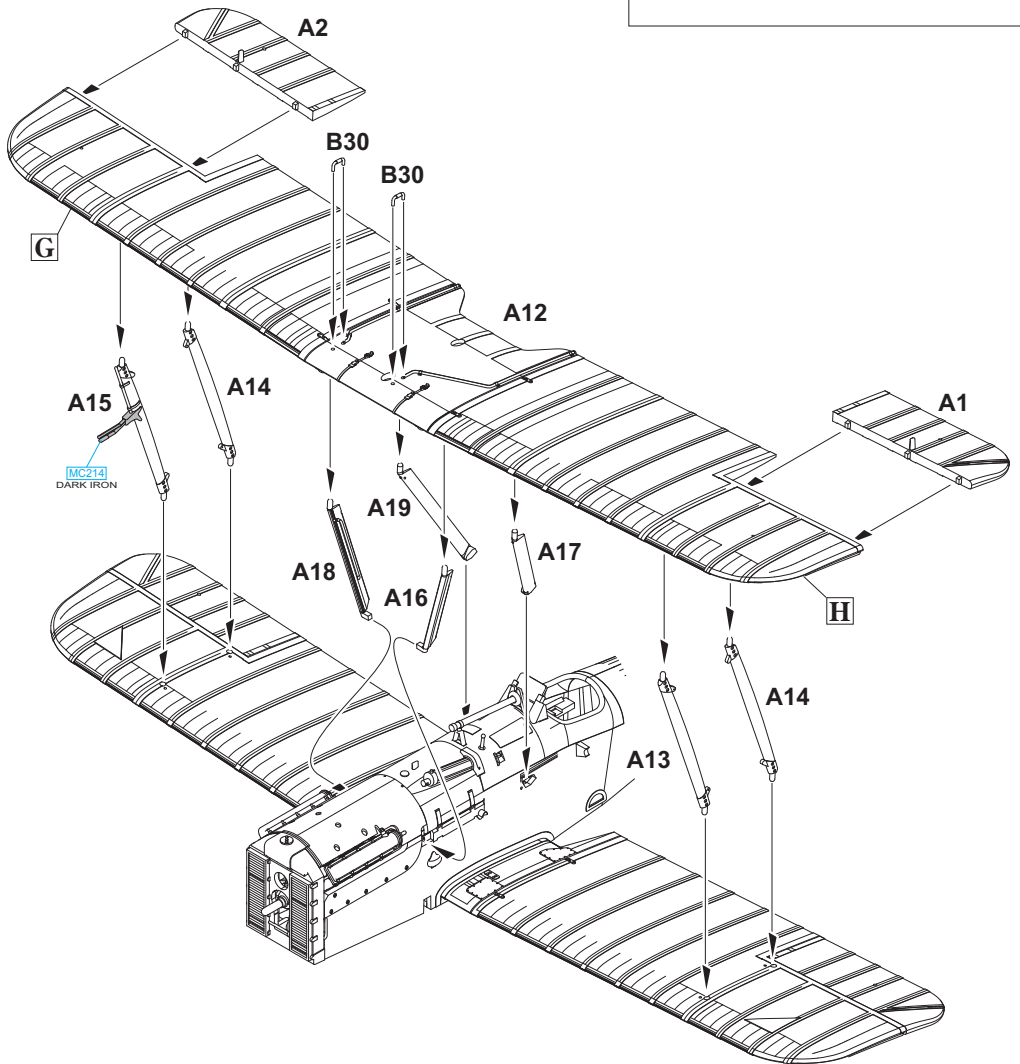
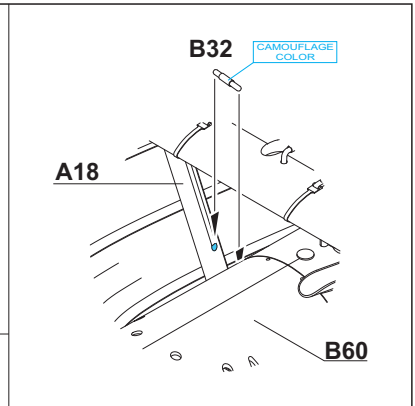
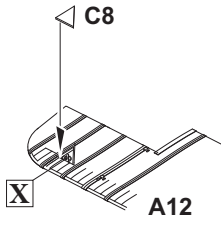
**G****H**

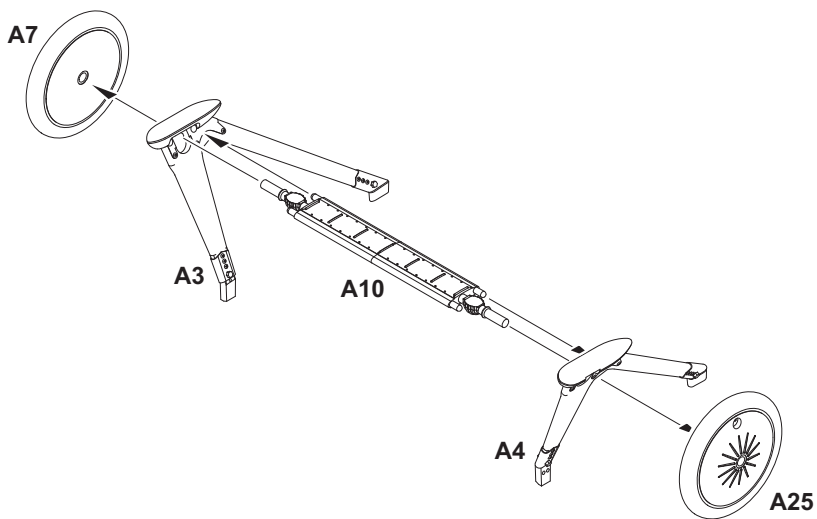
**J****MARKING A**

?

**MARKING B**