

intro

The onset of military jets necessitated new training airplanes, preparing student pilots for demanding machinery better than piston trainers. The Fouga Magister took off for first time during 1952 as the first successful example of this new breed. Shortly afterwards also the countries of the then Warsaw Pact (WP) realized the need for such an aircraft. The Czechoslovak Ministry of National Defense (MNO) specified the tactical and technical requirements for future jet trainer in 1955, demanding use of the domestic turbojet M710 engine with one stage axial-flow compressor, which was under the development at the time. The project took off under the C-29 designation with Zdeněk Rublič starting the work on the design immediately. Later on, Karel Tomáš joined him as a second main designer, and both were assisted by younger prospect Jan Vlček, who, in 1960, took the lead role in further development, as both the main designers retired. Later on Vlček used his experience from L-29 in design of successor L-39 Albatros. Shortly after the start of pre-design work the C-29 attracted attention of Soviet officials, who were acquainted with the project in early stage of development. The reason was obvious: while Czechoslovakia needed only some 100 of trainers, the demand of Soviet Union promised orders of thousands of them. The first consultations between Czech and Soviet representatives took place in Moscow in May 1956 and the requirement for turbojet engine with a robust radial-flow compressor instead of axial-flow one emerged as one of the main requests from Soviet side. A subsequent meeting in September 1956 confirmed it definitively, so engine designers of the Motorlet Jinočnice company started work on engine M701 with radial-flow compressor. Other demands from the Soviet side included extension of the flight endurance from 70 minutes to 120 minutes and also reduction of the landing speed from 105 mph (170 km/h) to 81 mph (130 km/h) was required. The wing area had to be increased from 17.5 m² to 19.8 m² with original split flaps replaced by the more efficient slotted flaps to achieve such a low speed safely.

First time airborne

At the beginning of 1957 production of the first five prototypes of L-29 (as the project was newly designated), was approved. Three of these were to be used for flight tests, one for structural tests and one, uncompleted, served as technological demonstrator. Since the M701 was not yet available, substitution had to be sought elsewhere and, as there was no suitable engine within the WP countries, it needed to be sourced from western (i.e. NATO) countries with the need to circumvent existing embargoes. Attempts to acquire two British Armstrong Siddeley Viper engines ended with smuggling them through Switzerland by Jaroslav Bejšovec, employee of the state owned Foreign Trade Company (PZO). The engines lacked technical documentation and also some parts like starter or gearbox, so they had to be manufactured locally without any technical support from the engine producer. The prototype No. 3 took off for the very first time on April 5th, 1959, at 2:50 pm with Rudolf Duchoň behind the controls. The XL-29.03 proved it was easy to fly, but later on, at higher speeds, problems with tail vibrations and aileron flatter emerged. During the attempts to solve the problems, prototype No. 1 was prepared to start flight tests with new M701 engine. The XL-29.01 conducted its maiden flight on July 12th, 1960, and later on also prototypes Nos. 2 and 3 got the new M701 turbojet. At the end of 1960 representatives of the MNO approved production of ten aircraft provided several lasting problems would be adjusted.

Comparative trials success

The grounds for the success of L-29 lies in victory in comparative trials with two competitors: the Polish TS-11 Iskra and the Soviet Jak-30. The trials took place on August 21st, 1961, in Soviet Monino and the Czechoslovak team showed up with the prototype No.3 upgraded with most of latest changes adopted already for serial production. Although the L-29 proved to be inferior to the competitors in terms of performance, it demonstrated best flying characteristics and had also upper hand in operational reliability. Hence was L-29 found as the most suitable for pilot training and declared winner of the trials. After the return of the XL-29.03 from Monino (September 28th, 1961), work began on some last adjustments. The horizontal stabilizer was changed and the air brakes got eight, then sixteen circular holes. During 1962 the production of the first ten aircraft was under way and starting with 11th example a new front fuselage was adopted (by 9,8 inch/ 25 cm longer). Also the rudder was changed and air brakes returned to unperforated variant during the later series. The intergovernmental agreement on L-29 delivery was signed between Czechoslovakia and Soviet Union in February 1963 and it put production under high stress as the USSR demanded the delivery of 2500 pieces over five years. Because of that, final assembly took place not only in Aero Vodochody (total production of 1943 L-29s), but also in second factory Let Kunovice (total production of 1722 L-29s, all destined for the USSR and other WP countries). The next development of the L-29 led to the L-29 R reconnaissance variant, the L-29 A aerobatics lightweight version and one seater L-29 RS used for advanced training. The trade name Delfín (Dolphin) was adopted in 1963, NATO assigned the L-29 with code name Maya.

Dolphin Warrior

Although the L-29 was a dedicated trainer, it has also been involved in several combat operations during its service, because it was exported to African and Middle Eastern markets with unstable countries. The first non WP customer was Syrian Arab Republic in 1964. The L-29 was used in combat for very first time in Nigeria, flown by government forces against the rebels led by General Ojukwu in 1967. Upon rebellion in Uganda, the L-29s attacked ground targets with rockets and bombs when used against the governmental forces of General Amin in 1978. L-29s were also used by Egypt in the Arab-Israeli wars. They were modified to allow two pylons, each with four 80mm rockets, under each wing. It was quite rough modification of the wing design, which luckily went well... All in all, the Aero L-29 Delfín served successfully with 24 air forces and many of them are still in flight condition in private hands. With the total of 3665 examples produced, the L-29 Delfín is so far the mostly produced jet trainer in history.

PLASTIC PARTS

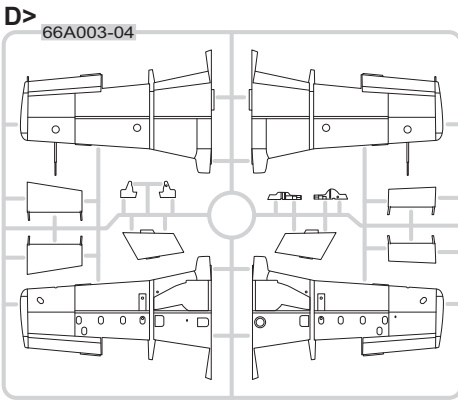
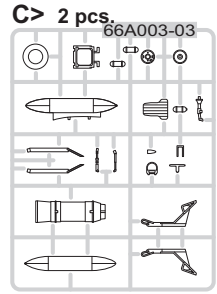
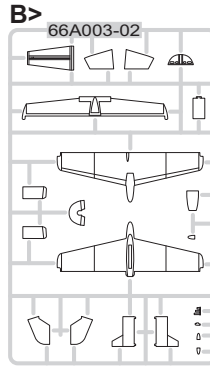
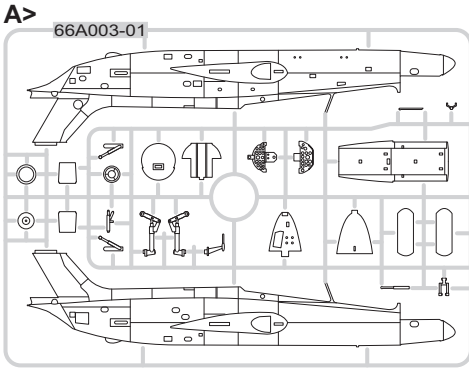

PE - PHOTO ETCHED DETAIL PARTS

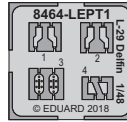

GUNZE	MISSION MODELS	COLOR
H3	C3	MMP-003 RED
H12	C33	MMP-047 FLAT BLACK
H52	C12	MMP-091 OLIVE DRAB
H76	C61	MMM-001 BURNT IRON
H77	C137	MMP-040 TIRE BLACK
H90	C47	CLEAR RED
H94	C138	CLEAR GREEN
H315	C315	MMP-069 GRAY
H317	C317	MMP-064 GRAY
H329	C329	MMP-041 YELLOW
H334	C334	MMP-102 BARLEY GRAY
H413	C113	MMP-090 YELLOW
	C92	SEMI GLOSS BLACK

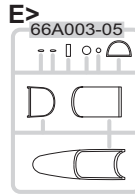

Mr.METAL COLOR	METALLICS
MC213	MMM-006 STAINLESS

Mr.COLOR SUPER METALLIC	METALLICS
SM01	MMC-001 SUPER FINE SILVER

Mr.COLOR GX	PAINTS
GX5	MMP-048 BLUE

-Parts not for use. -Teile werden nicht verwendet. -Pièces à ne pas utiliser. -Tyto díly nepoužívejte při stavbě. - 使用しない部品

ATTENTION * UPOZORNĚNÍ * ACHTUNG * ATTENTION

- (GB)** Carefully read instruction sheet before assembling. When you use glue or paint, do not use near open flame and use in well ventilated room. Keep out of reach of small children. Children must not be allowed to suck any part, or pull vinyl bag over the head.
- (CZ)** Před započetím stavby si pečlivě prostudujte stavební návod. Při používání barev a lepidel pracujte v dobře větrané místnosti. Lepidla ani barvy nepoužívejte v blízkosti otevřeného ohně. Model není určen malým dětem, mohlo by dojít k požití drobných dílů.
- (D)** Vor dem Zusammenbau die Bauanleitung gut durchlesen. Kleber und Farben nicht in der Nähe von offenem Feuer verwenden und für eine ausreichende Belüftung sorgen. Den Bausatz von kleinen Kindern fernhalten. Vermeiden Sie, dass Kinder Bauteile in den Mund nehmen oder sich Plastiktüten über den Kopf ziehen.
- (F)** lire soigneusement la fiche d'instructions avant d'assembler. Ne pas utiliser de colle ou de peinture à proximité d'une flamme nue, et aérer la pièce de temps en temps. Garder hors de portée des enfants en bas âge. Ne pas laisser les enfants mettre en bouche ou sucer les pièces, ou passer un sachet vinyl sur la tête.

INSTRUCTION SIGNS * INSTR. SYMBOLY * INSTRUKTION SINNBILDEN * SYMBOLES

- OPTIONAL VOLBA
- BEND OHNOUT
- OPEN HOLE VYVRTAT OTVOR
- SYMETRICAL ASSEMBLY SYMETRICKÁ MONTÁŽ
- REMOVE ODŘÍZNOUT
- REVERSE SIDE OTOČIT

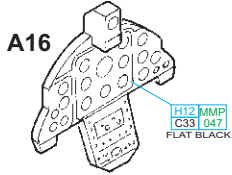
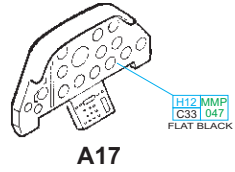
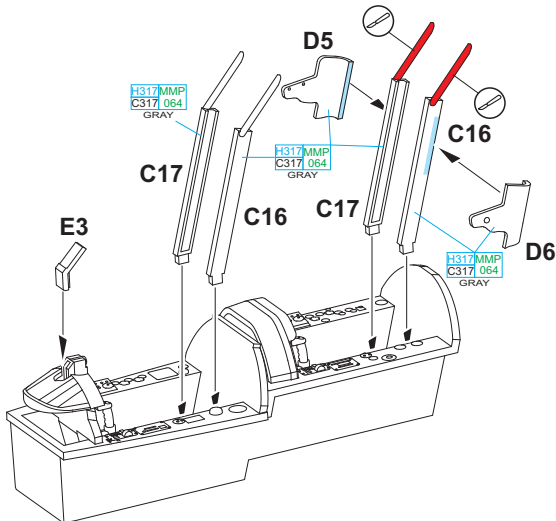
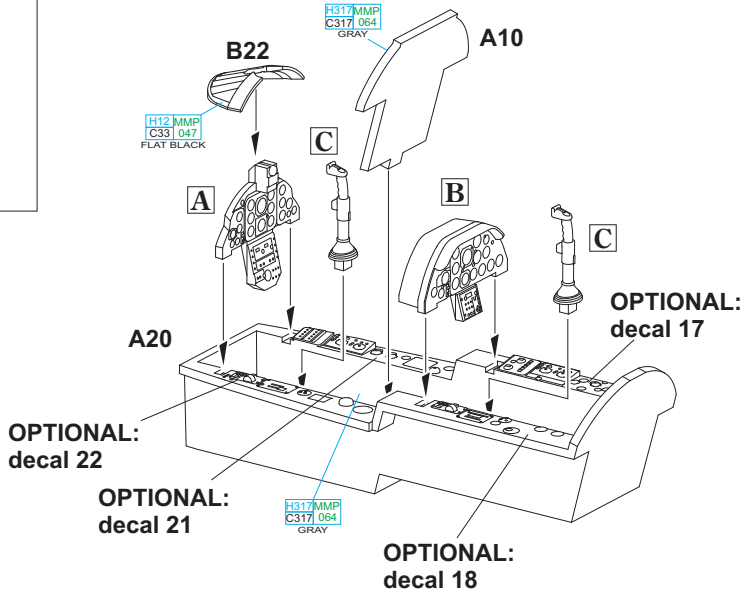
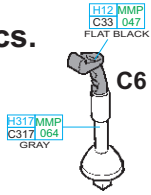
A**OPTIONAL:
decal 23, 24****B****OPTIONAL:
decal 19, 20****C****2 pcs.**

D 2 pcs.

REAR SEAT ONLY

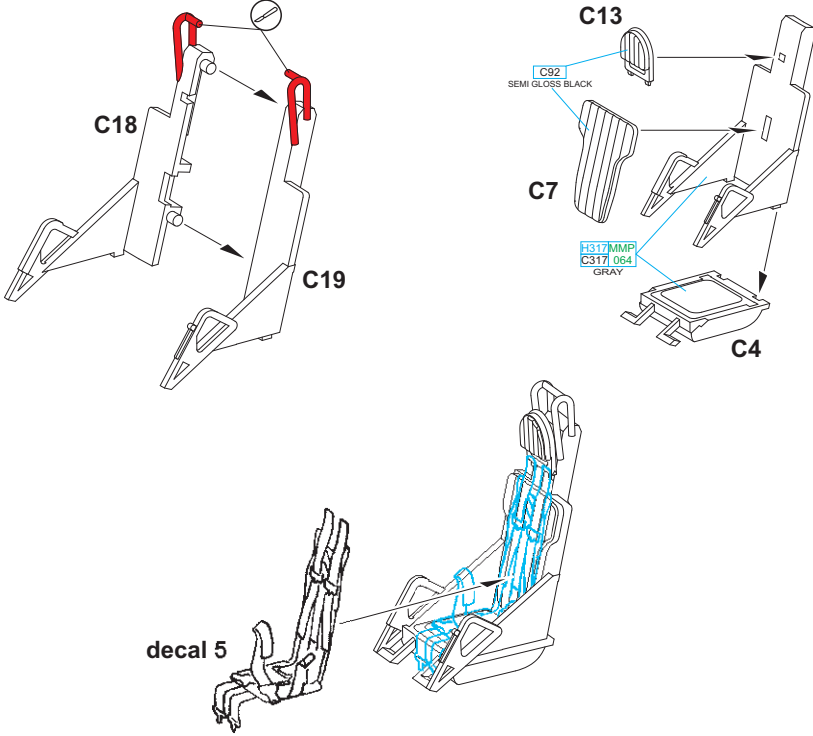

E

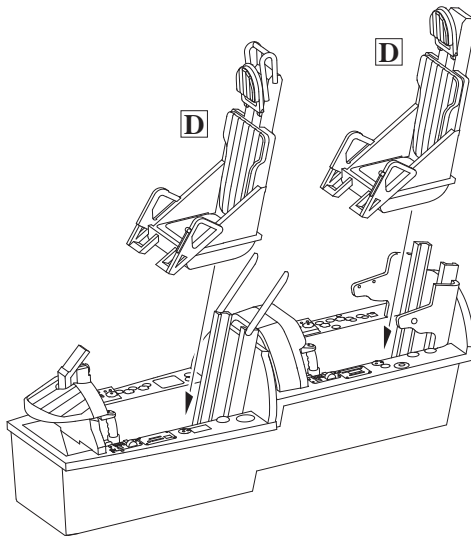

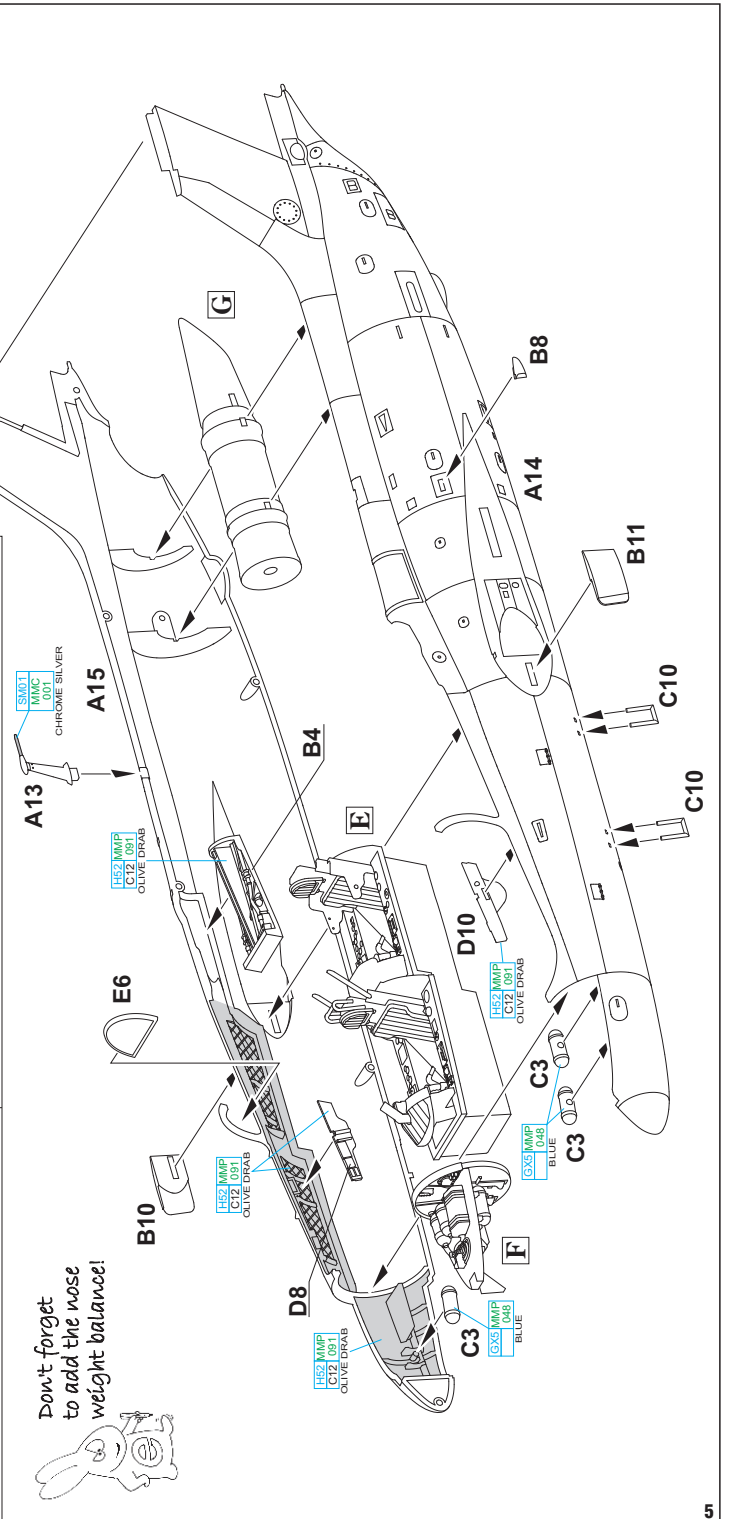
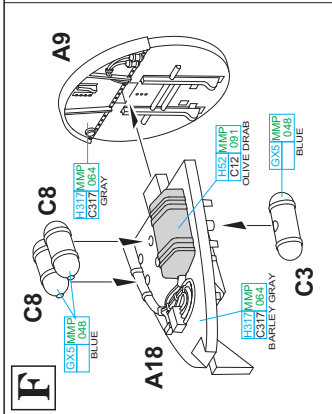
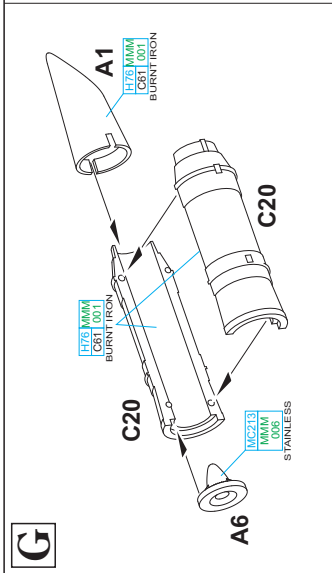

Don't forget
to add the nose
weight balance!

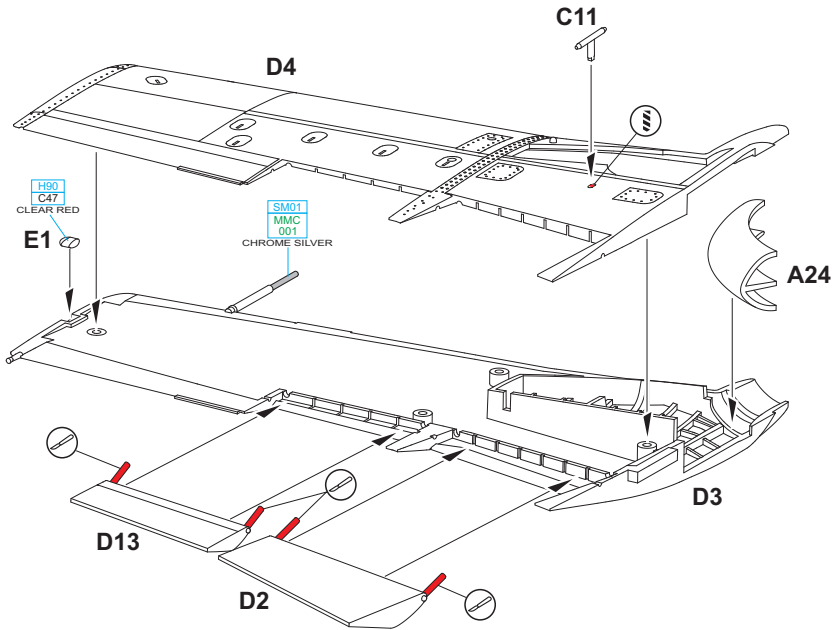
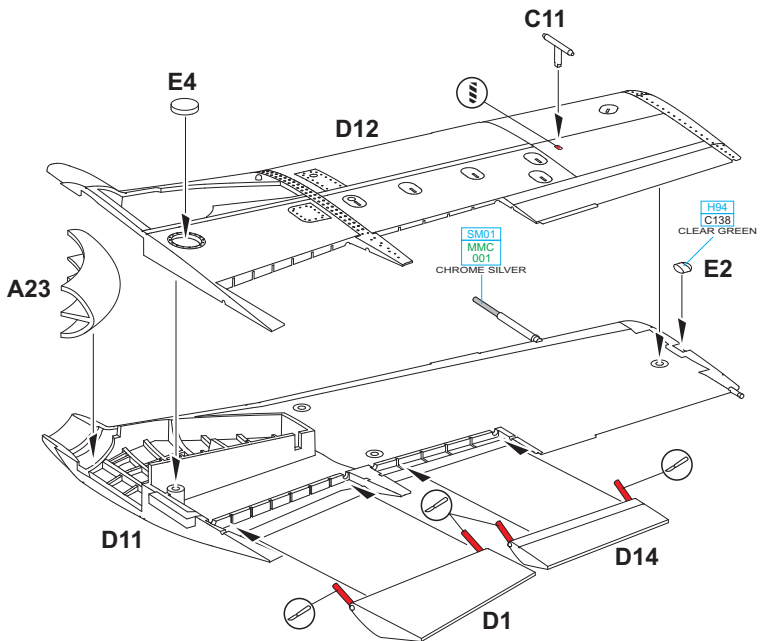
I**J**

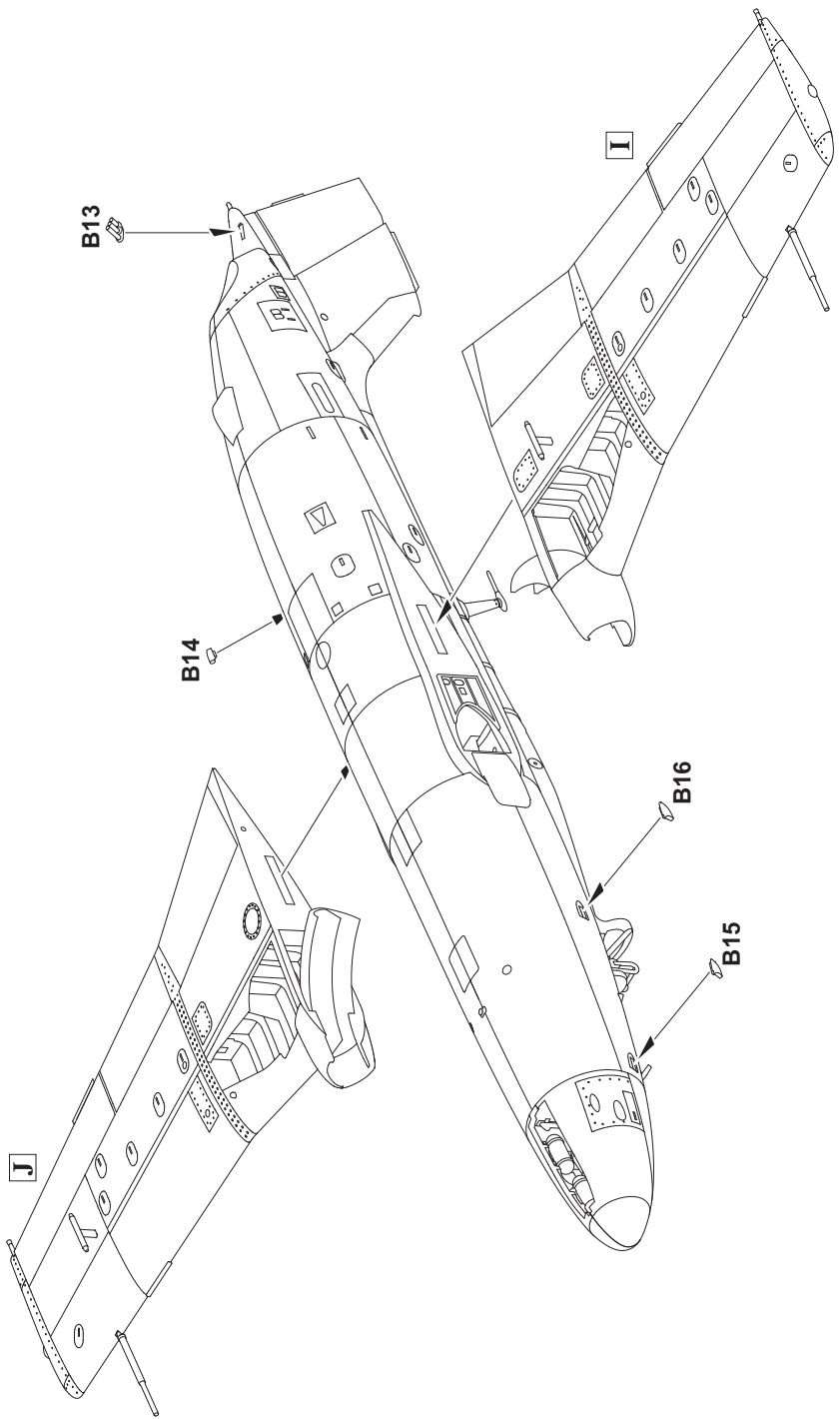

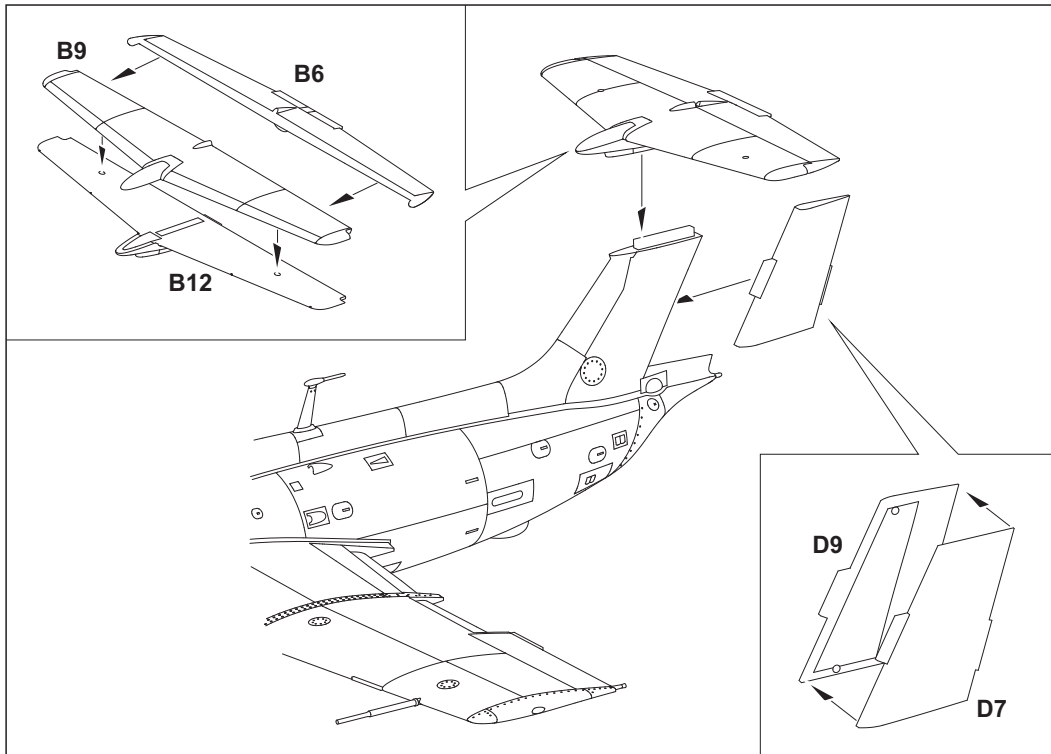

K

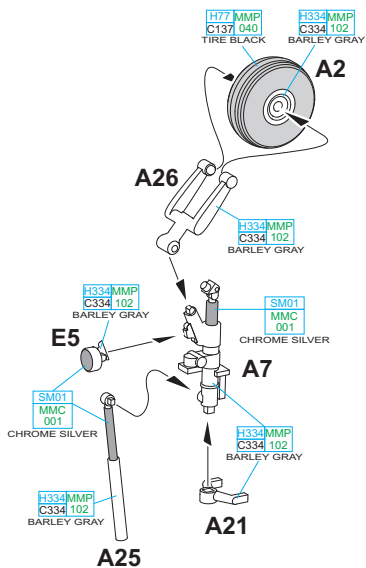

L

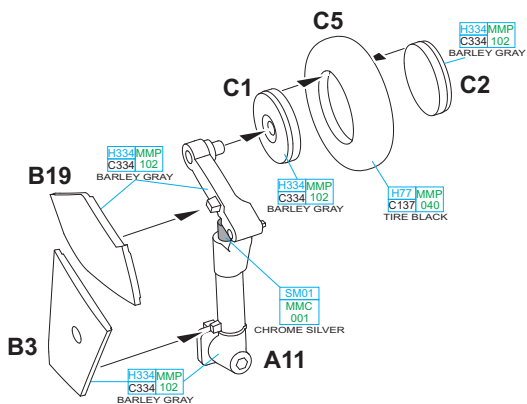

M

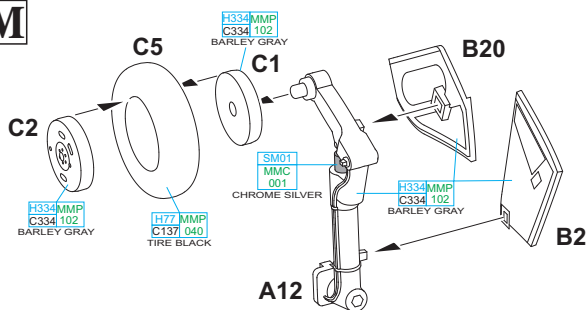

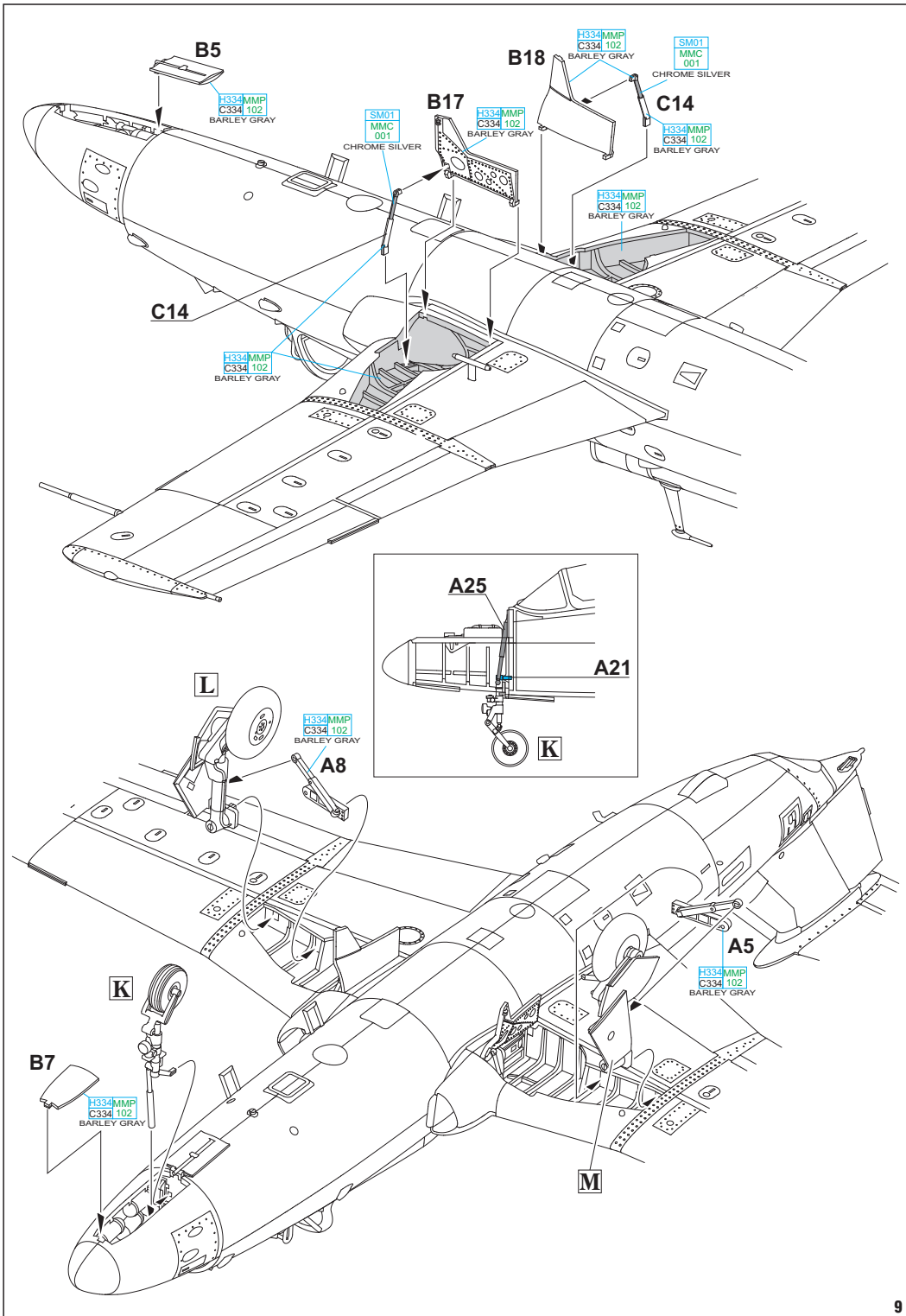

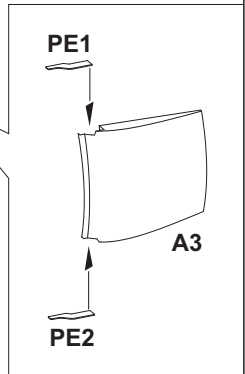
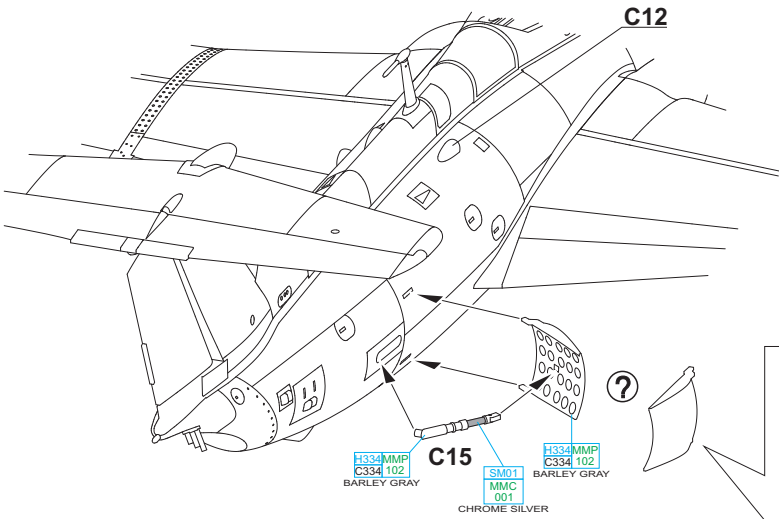
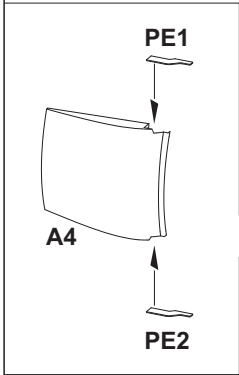
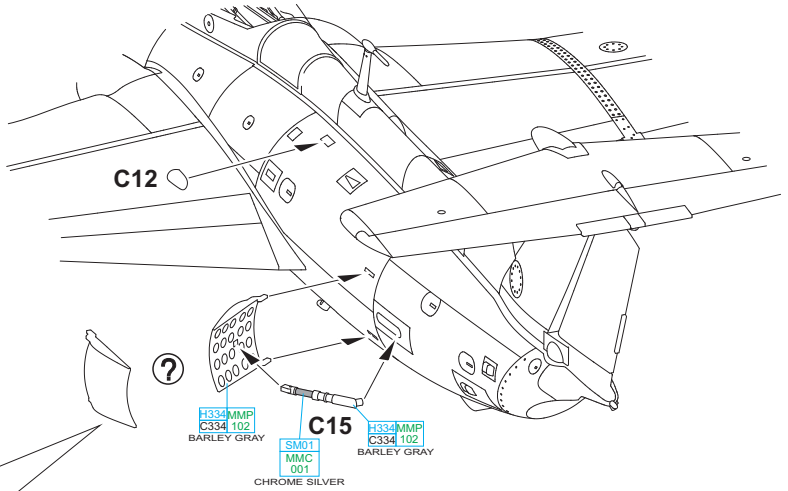

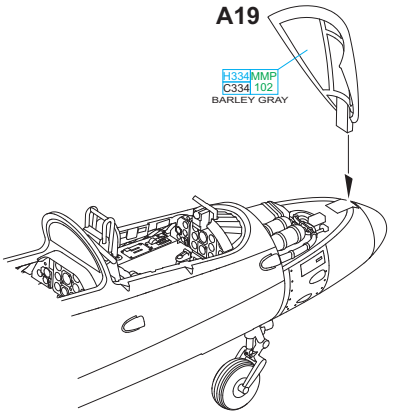
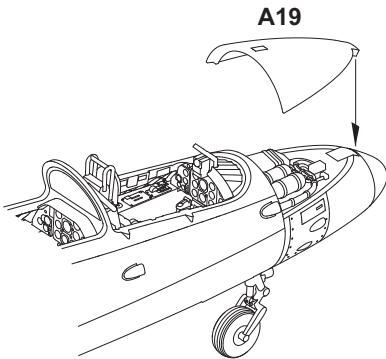
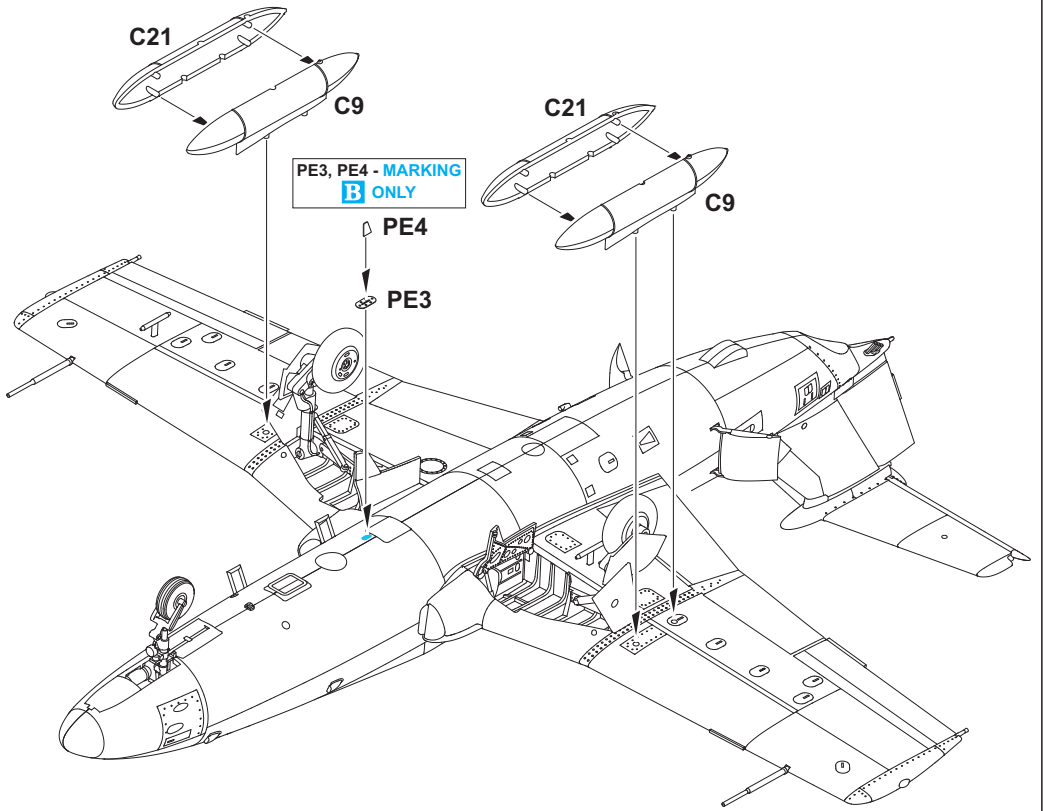

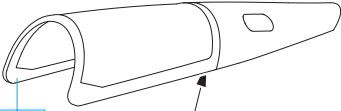
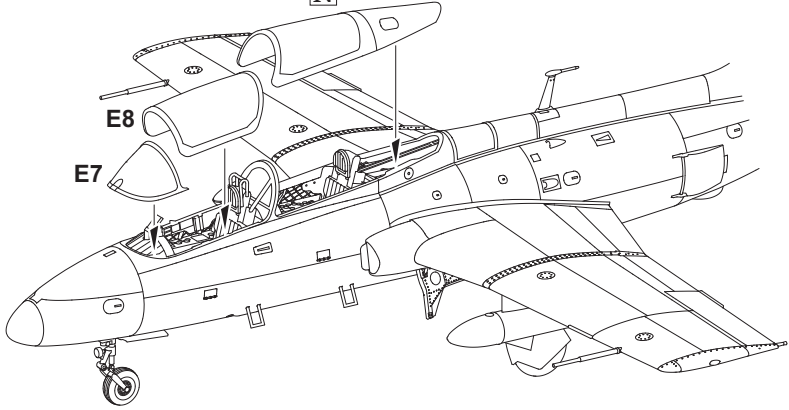
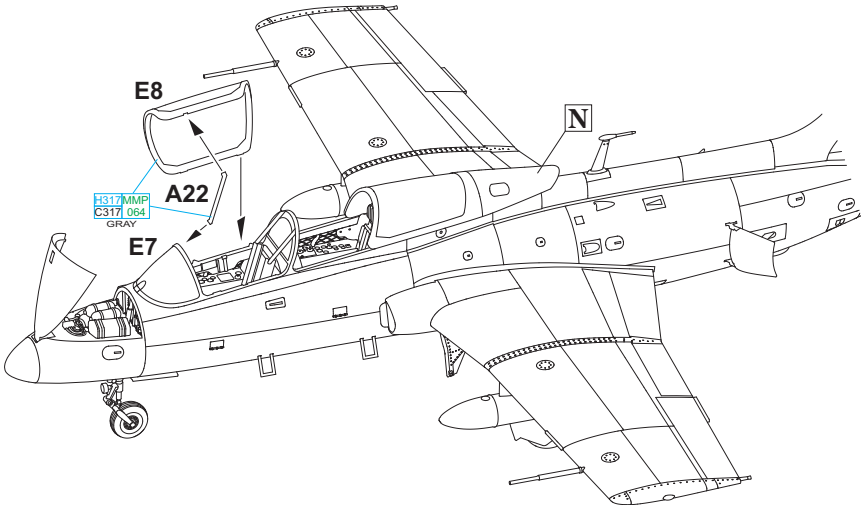
N**E9****H317 MMP**
C317 064
GRAY**B1****H317 MMP**
C317 064
GRAY**N****E8****E7****?****E8****A22****E7****H317 MMP**
C317 064
GRAY

A a/c No. 2853, 1st Flight, 11th Fighter Regiment, Žatec, Czech Republic, 1993

This Zatec Delfin received this finish at the beginning of June 1993. Its development was undertaken by the ground crew under the leadership of Captain Ing. Karel Krejčí. Its introduction to the public came on July 10th of the same year at an airshow in Žatec. After the disbandment of the 11th Fighter Regiment, the aircraft was transferred to the 1st Training Regiment at Přerov. The entire aircraft, including the drop tanks, was cleaned and degreased and the national insignia and fuselage number were covered by tape. After that, the aircraft was painted yellow, followed by the black tiger stripes.

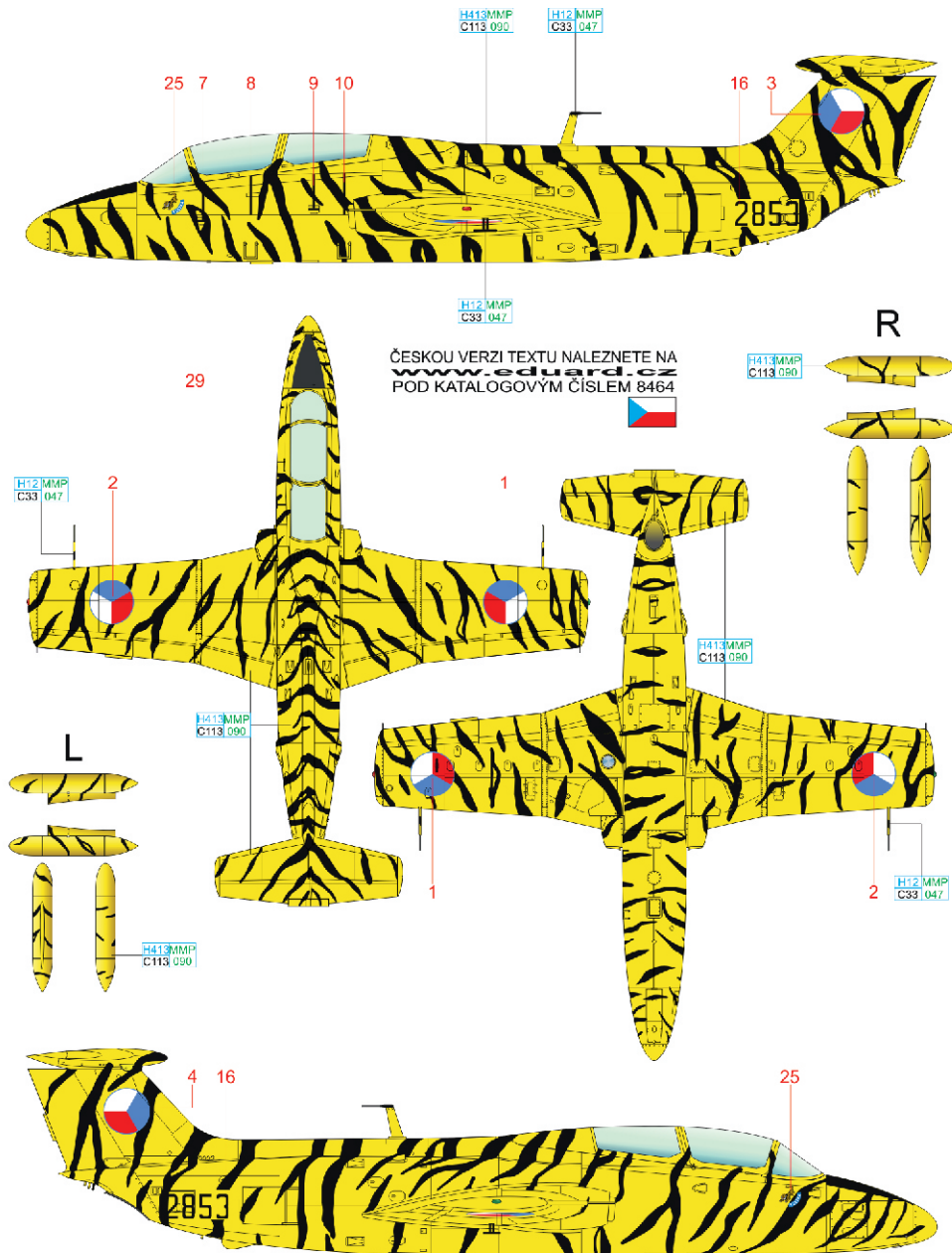

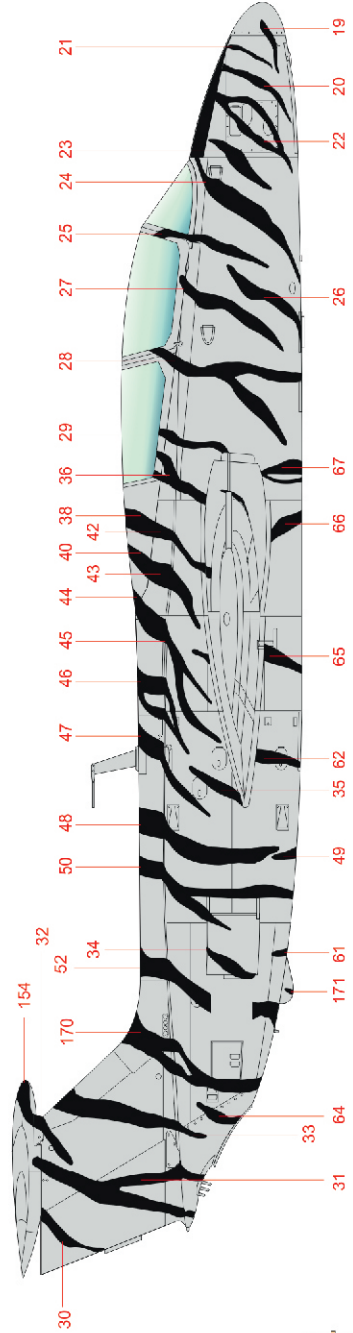
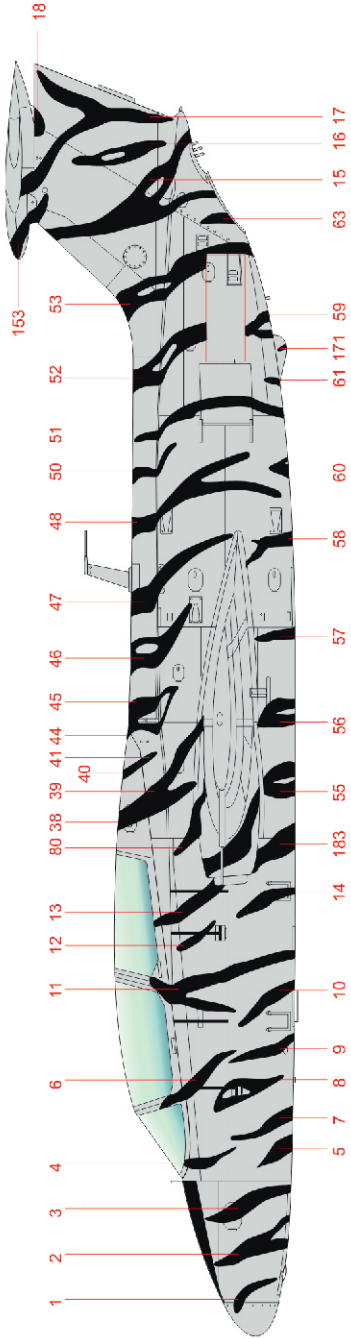

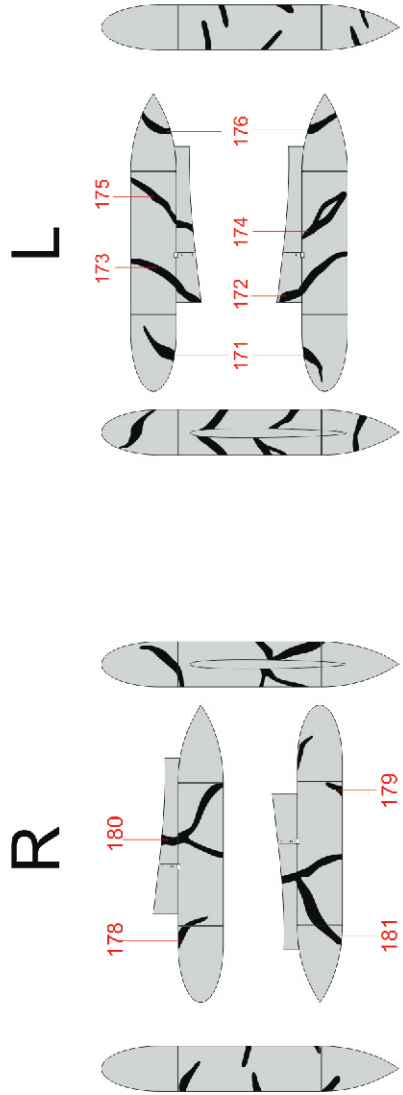
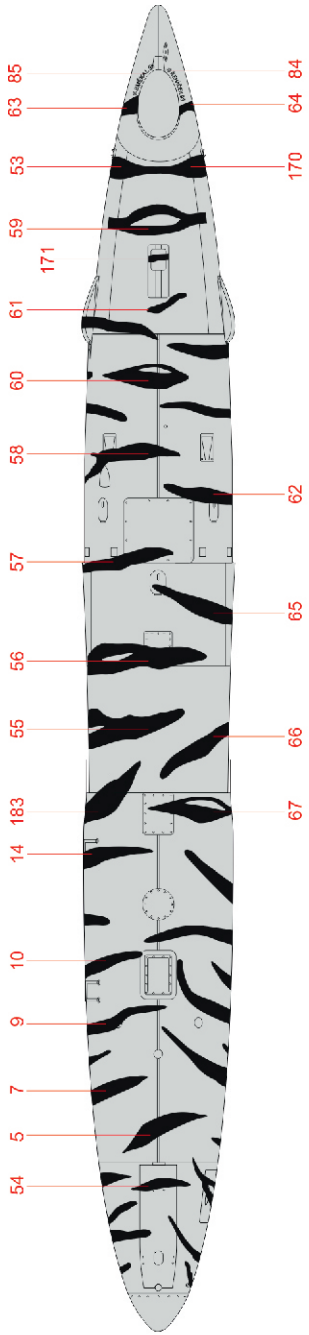

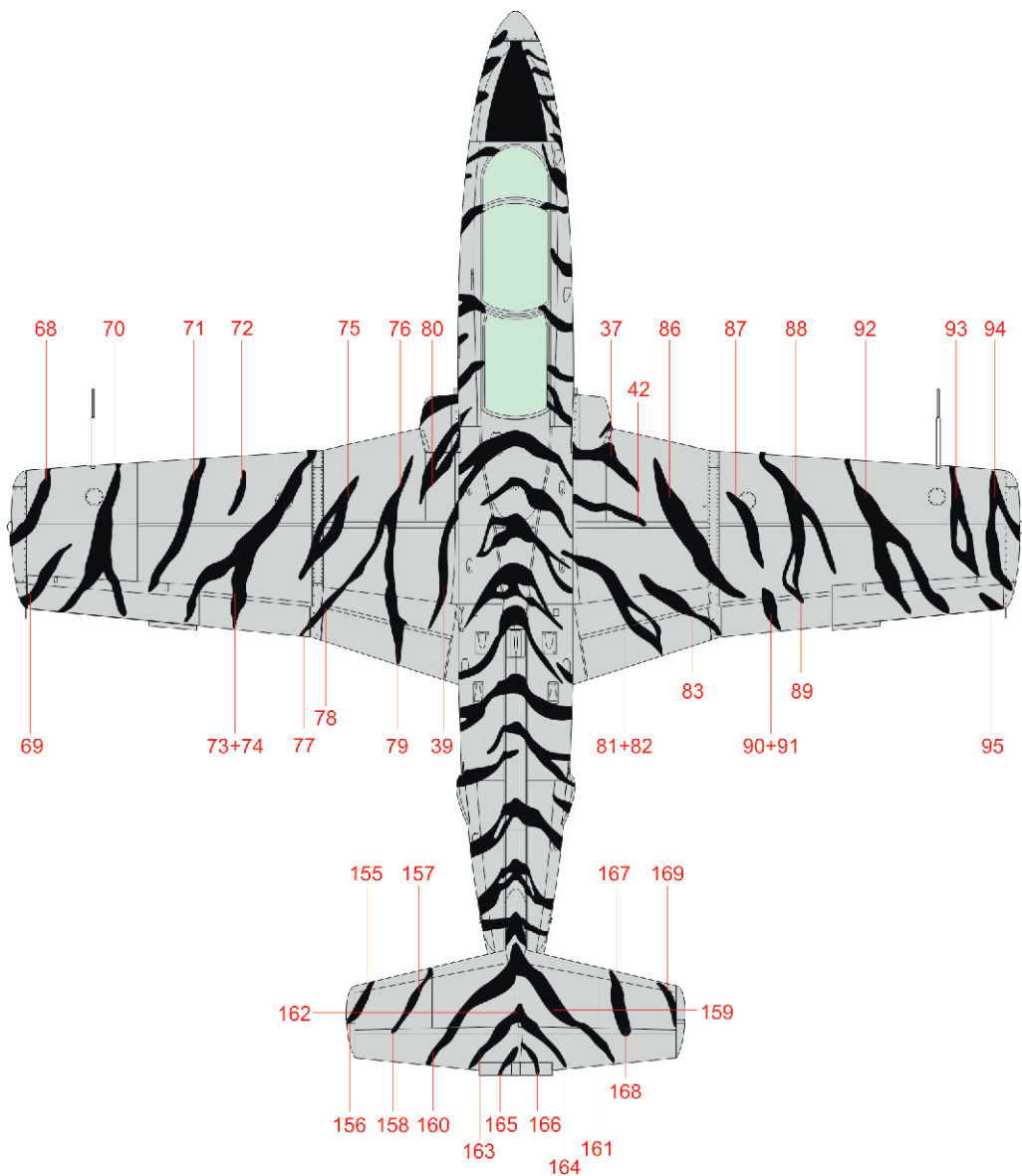

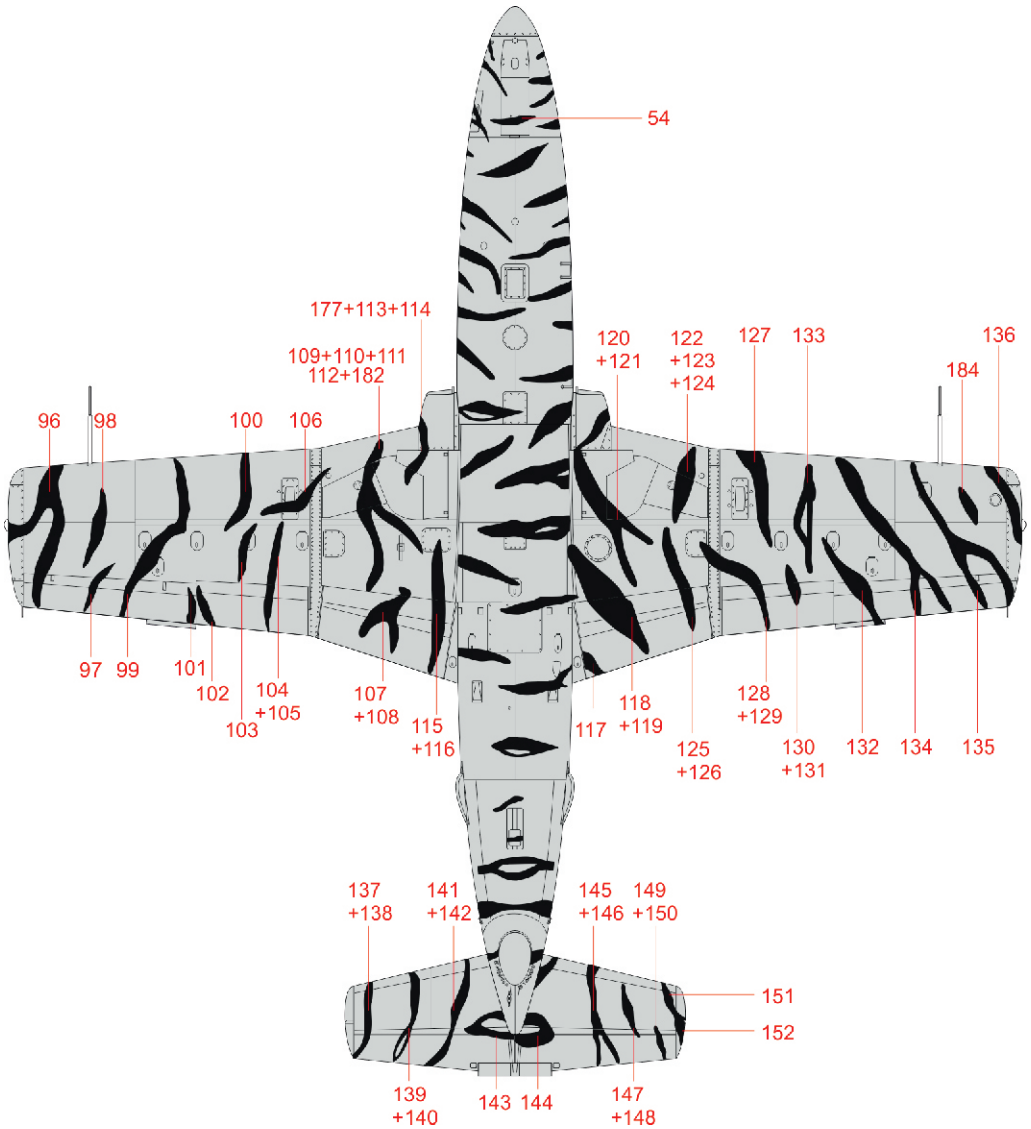

B a/c No. 1928, 3rd Air Base Malacky, Slovakia, 1993

The separation of Czechoslovakia into the Czech and Slovak Republics on New Year's Eve of 1992/1993 also projected itself on military assets. This included the division of the L-29 inventory. On December 31st, 1992, Czechoslovakia operated fifty L-29s. The Czech Republic received a total of 34 of these, and the Slovak Republic sixteen. Among the L-29s that were operated by the Slovak Air Force was 1928. It carried a paint scheme consisting of grey in which they came off of the production line. The aircraft crashed for undetermined reasons on September 20th, 1996 not far from Studienka. The pilot, Mjr. Tomáš Novotný successfully ejected from the airplane.

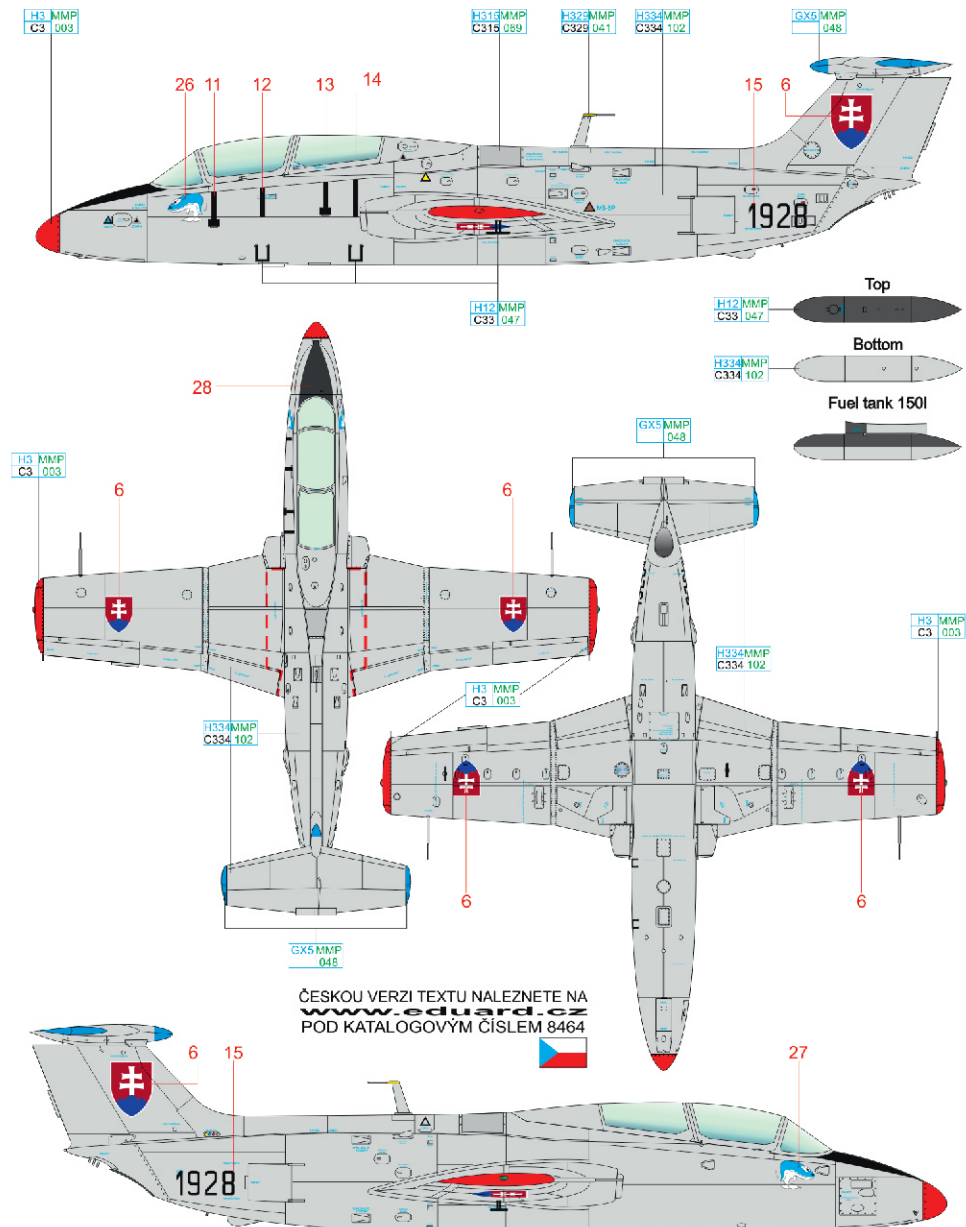

BARLEY H334 MMP GRAY H315 MMP BLACK H12 MMP BLUE GX5 MMP RED H3 MMP YELLOW H329 MMP
GRAY C334 102 GRAY C315 089 BLACK C33 047 BLUE 048 RED C3 003 YELLOW C329 041

