

PLASTIC PARTS

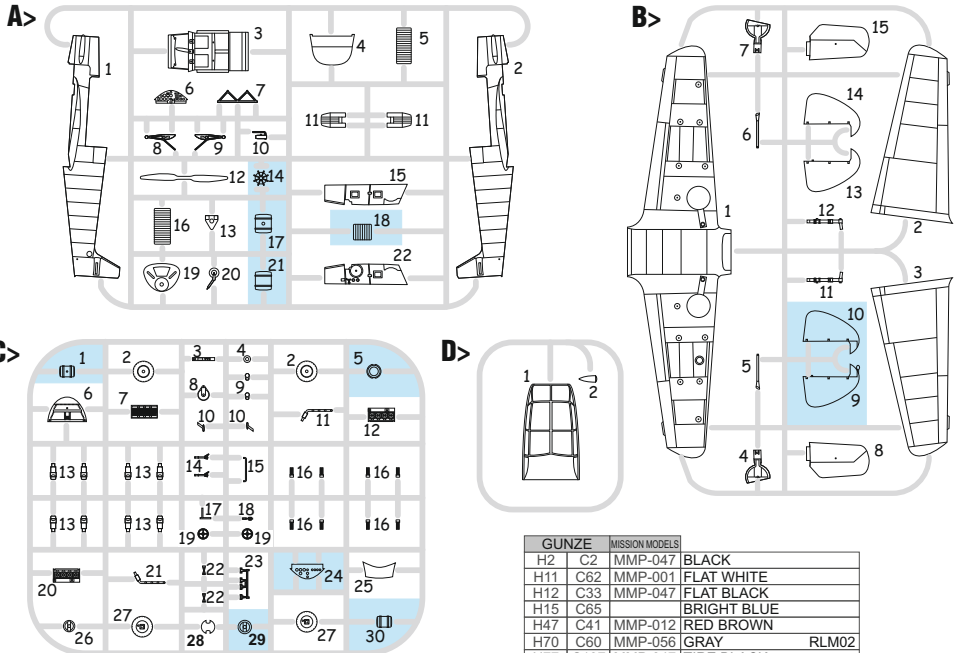

GUNZE	MISSION MODELS		
H2	C2	MMP-047	BLACK
H11	C62	MMP-001	FLAT WHITE
H12	C33	MMP-047	FLAT BLACK
H15	C65		BRIGHT BLUE
H47	C41	MMP-012	RED BROWN
H70	C60	MMP-056	GRAY
H77	C137	MMP-047	TIRE BLACK
H324	C324	MMP-116	LIGHT GRAY
H414	C114	MMP-003	RED
			RLM02
			RLM23
METAL	METALLICS		
MC218	MMM-003	ALUMINIUM	
MC219	MMM-009	BRASS	
M/COLOR	METALLICS		
SM01	MMC-001	SUPER CHROME	

-Parts not for use. -Teile werden nicht verwendet. -Pièces à ne pas utiliser. -Tyto díly nepoužívejte při stavbě. - 使用しない部品

ATTENTION * UPOZORNĚNÍ * ACHTUNG * ATTENTION

GB

Carefully read instruction sheet before assembling. When you use glue or paint, do not use near open flame and use in well ventilated room. Keep out of reach of small children. Children must not be allowed to suck any part, or pull vinyl bag over the head.

CZ

Před započatím stavby si pečlivě prostudujte stavební návod. Při používání barev a lepidel pracujte v dobře větrané místnosti. Lepidla ani barvy nepoužívejte v blízkosti otevřeného ohně. Model není určen malým dětem, mohlo by dojít k požití drobných dílů.

D

Vor dem Zusammenbau die Bauanleitung gut durchlesen. Kleber und Farben nicht in der Nähe von offenem Feuer verwenden und für eine ausreichende Belüftung sorgen. Den Bausatz von kleinen Kindern fernhalten. Vermeiden Sie, dass Kinder Bauteile in den Mund nehmen oder sich Plastiktüten über den Kopf ziehen.

F

lire soigneusement la fiche d'instructions avant d'assembler. Ne pas utiliser de colle ou de peinture à proximité d'une flamme nue, et aérer la pièce de temps en temps. Garder hors de portée des enfants en bas âge. Ne pas laisser les enfants mettre en bouche ou sucer les pièces, ou passer un sachet vinyl sur la tête.

INSTRUCTION SIGNS * INSTR. SYMBOLY * INSTRUKTION SINNBILDEN * SYMBOLES

OPTIONAL
VOLBA

BEND
OHNOUT

SAND
BROUSIT

OPEN HOLE
VYVRTAT OTVOR

SYMMETRICAL ASSEMBLY
SYMETRICKÁ MONTÁŽ

REMOVE
ODRŮZNOUT

REVERSE SIDE
OTOČIT

APPLY EDUARD MASK
AND PAINT
POUŽIT EDUARD MASK
NABARVIT

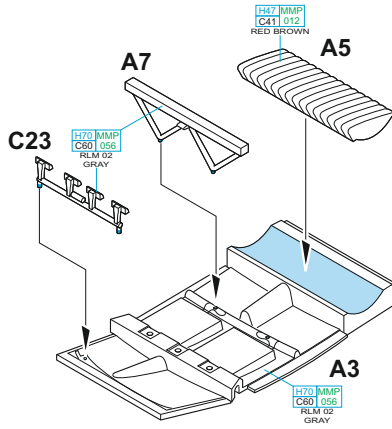

A 2 pcs.

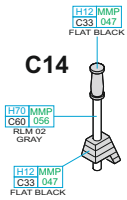

B 2 pcs.

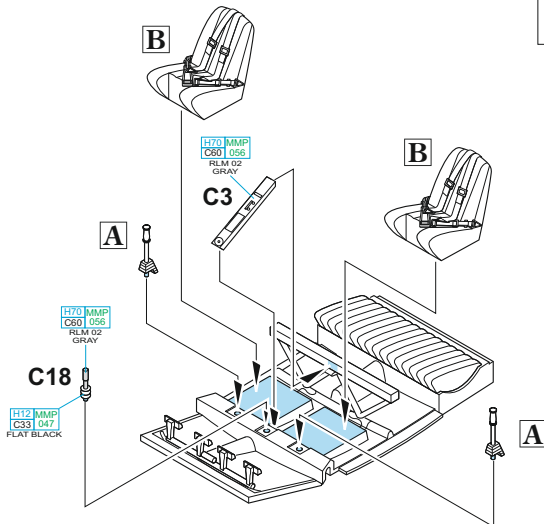
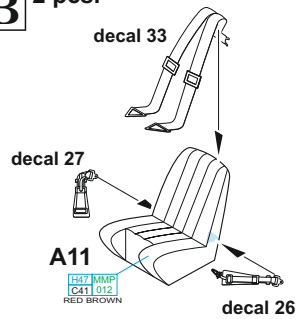

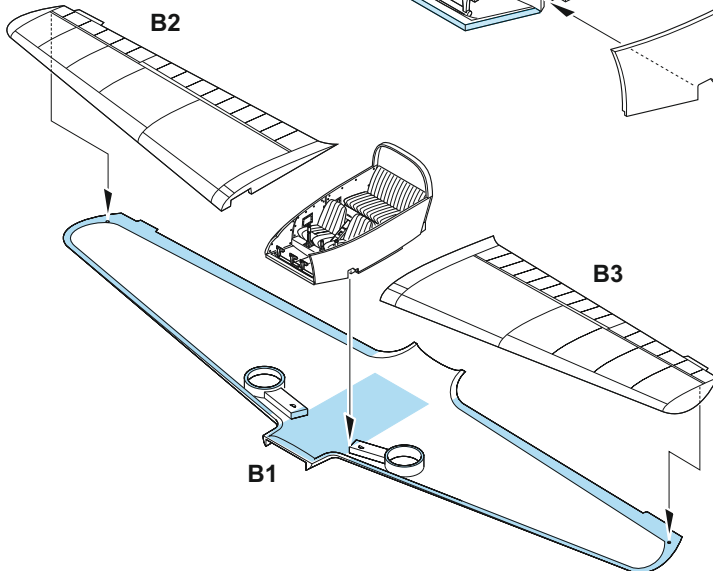
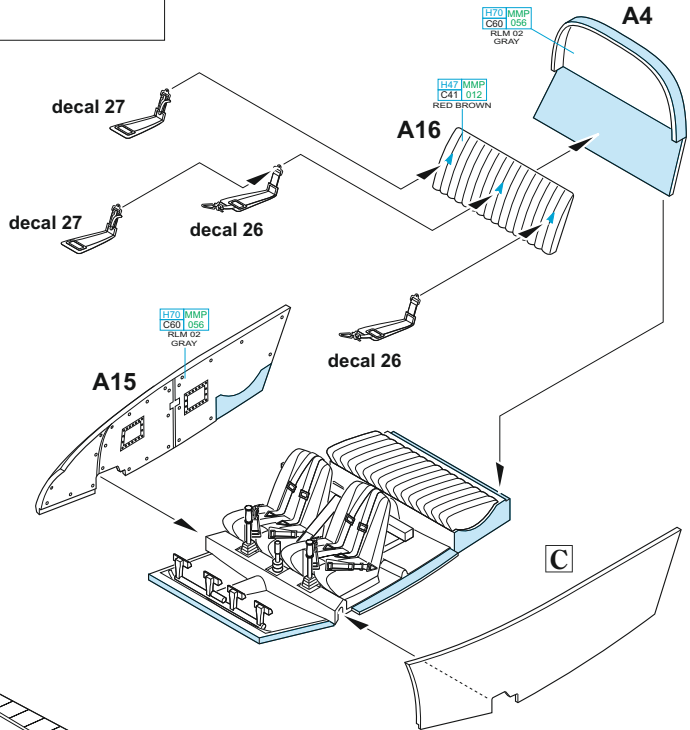
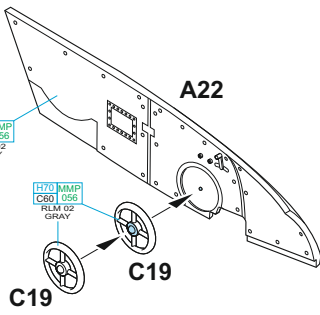
C

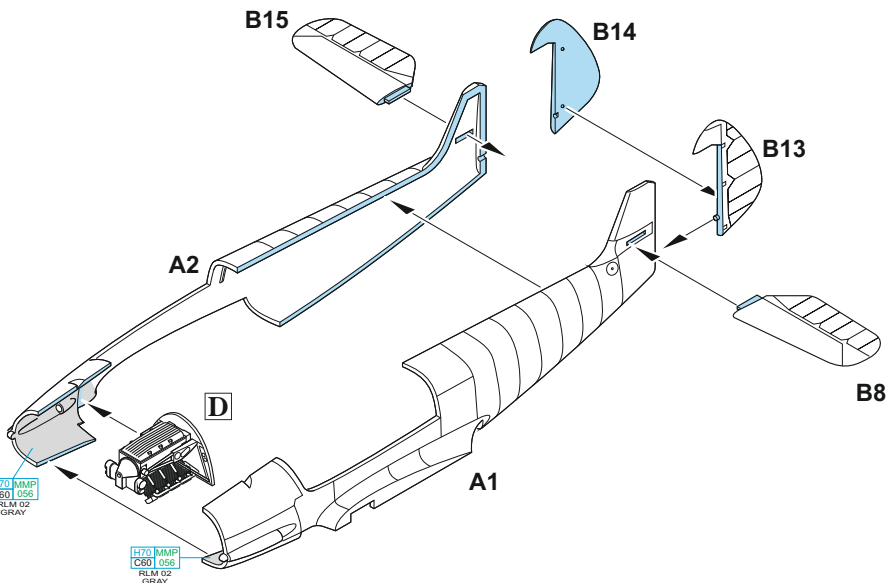
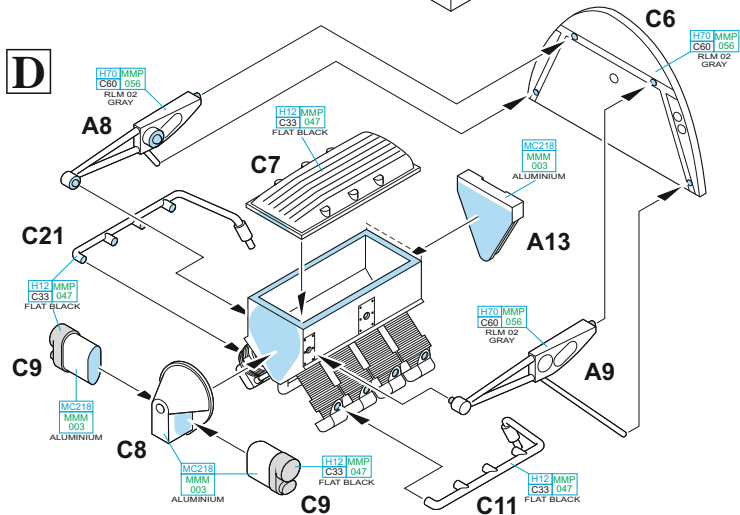
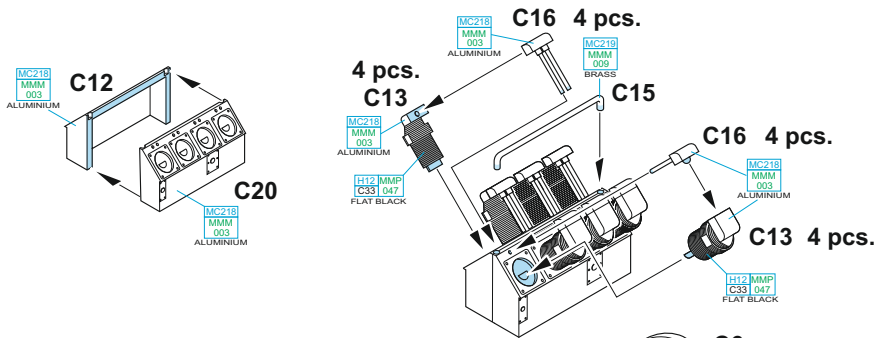

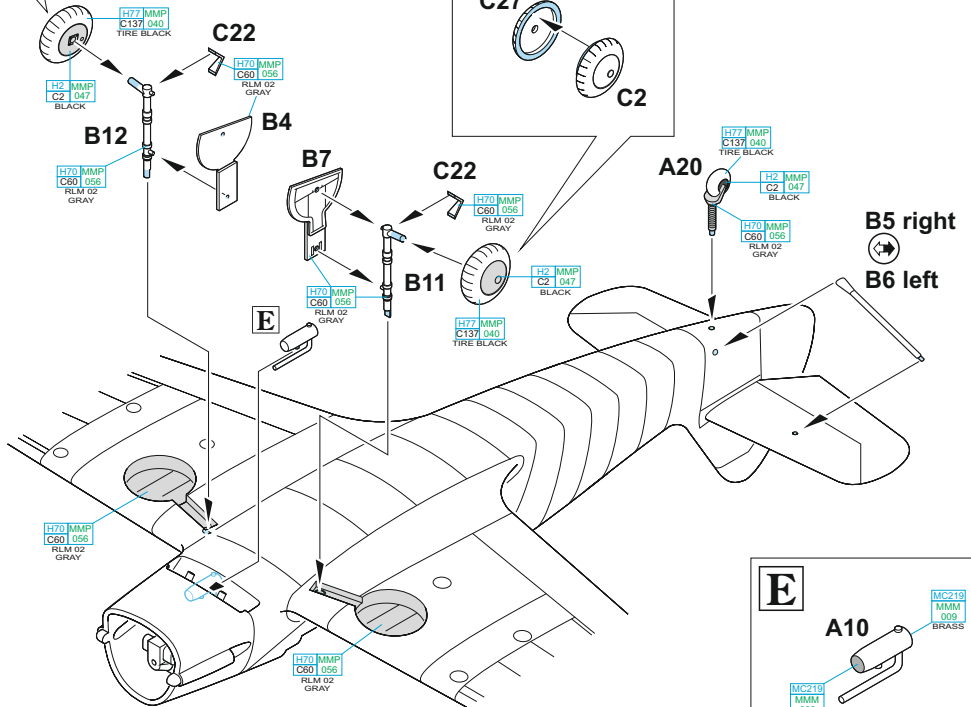
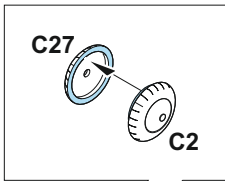
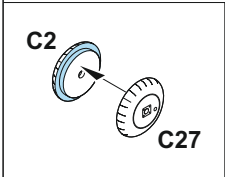
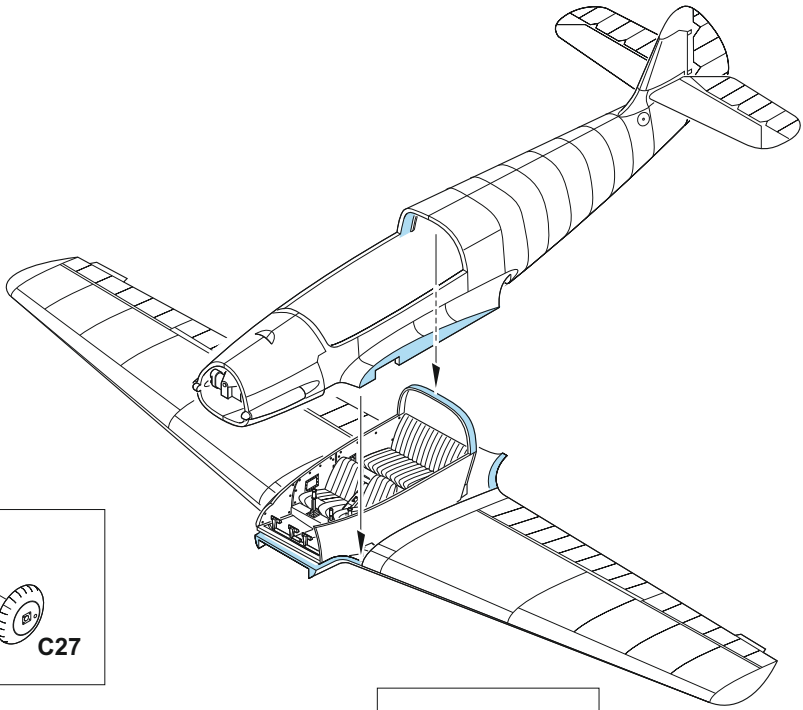

C25

H12 MMP
C33 C47
FLAT BLACK

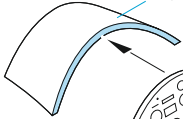

A6

H12 MMP
C33 C47
FLAT BLACK

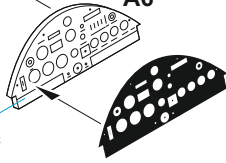

OPTIONAL: decal 10

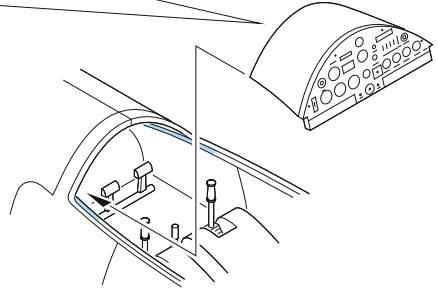

C10

B1

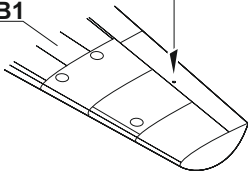

D1

H70 MMP
C60 C56
FLAT DZ
GRAY

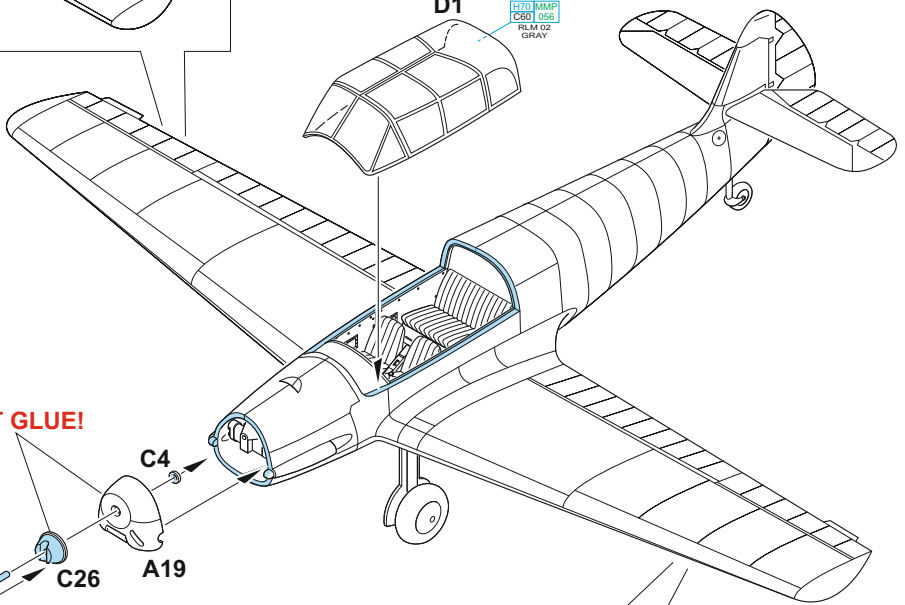

DO NOT GLUE!

C4

A12

C26

A19

C28

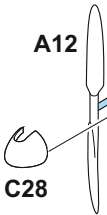

D2

C10

C17

B1

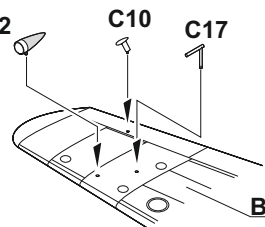

A Manx Air Races, Isle of Man, May 1937

Two Messerschmitt Bf 108Bs took part in the air races that took place in May 1937. These were piloted by Majors Seidemann and Ernst Gerbrecht. Both aircraft were sprayed blue overall, with registration on the wings and fuselage, and also carrying the race number on the nose. The main race was won by Major Seidemann, and in the secondary Tynwald Air Race, he finished second followed by Ernst Gerbrecht.

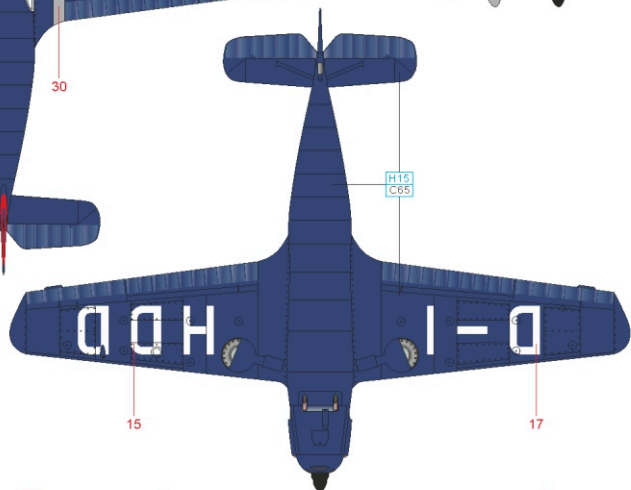
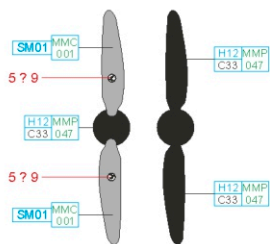
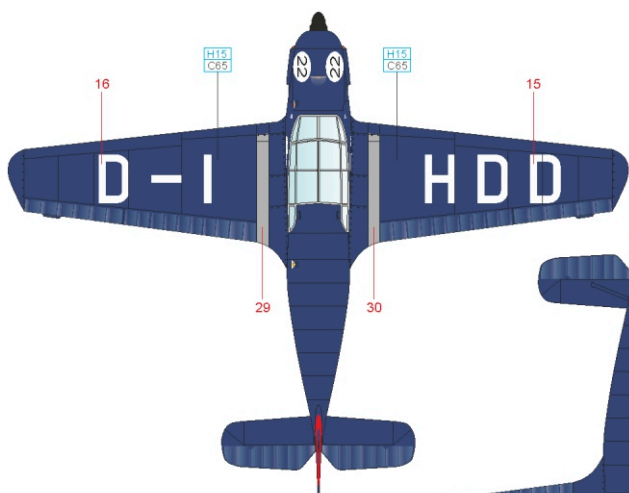
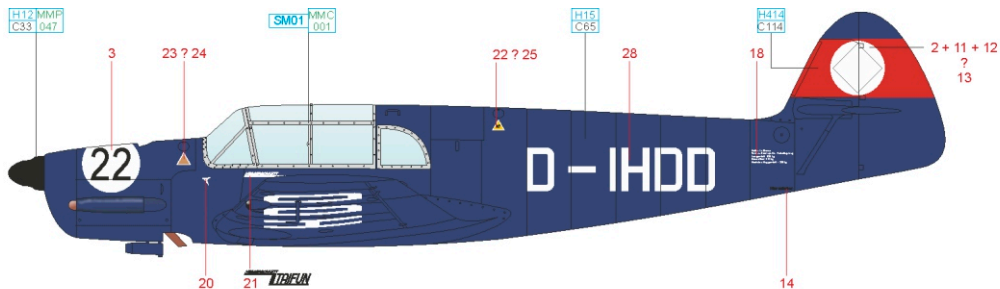

ČESKOU VERZI TEXTU NALEZNETE NA
www.eduard.com
POD KATALOGOVÝM ČÍSLEM 8479

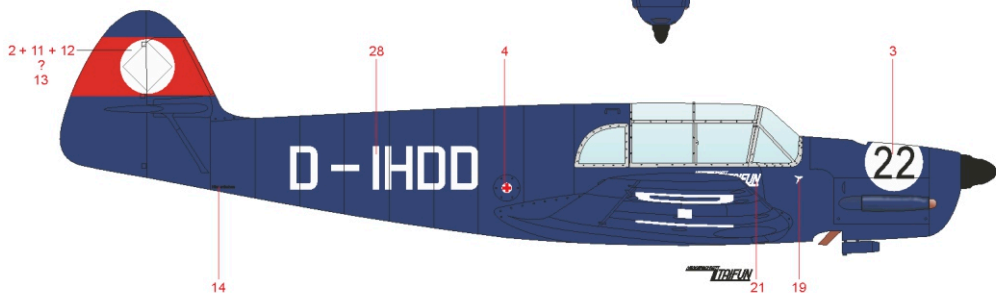

BLUE H15 C65 CHROME SM01 MMC 001 BLACK H12 MMP C33 047 RLM 23 H14 C114

eduard

B Manchuria Aviation Company, Chanchung Airfield, Manchuria, 1945

The Manchuria Aviation Company was founded on September 26th, 1931, by request of the Japanese military. Its main task was to provide transport and logistical support to the army, with mail runs and passenger service being offered if capacity allowed. One of the types that was operated by the company was the Bf 108, delivered through the mid thirties to the tune of fifteen units. This aircraft was discovered by Soviet troops at Manchung in an all-grey scheme with the dedication 'Aikoku No.258' and a black outlined white band on the rear fuselage, which were reserved for civil operators.

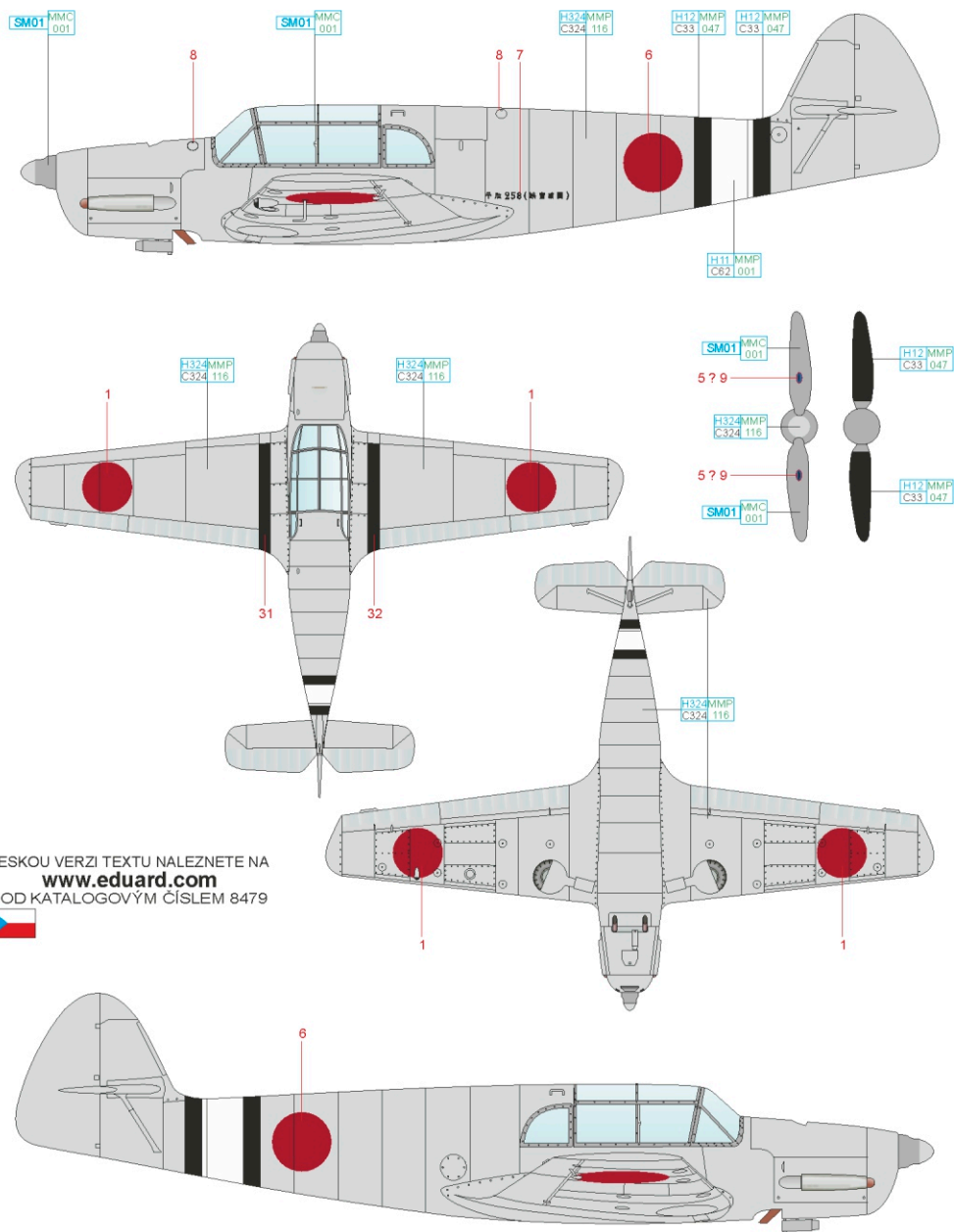

ČESKOU VERZI TEXTU NALEZNETE NA
www.eduard.com
 POD KATALOGOVÝM ČÍSLEM 8479

