

PLASTIC PARTS

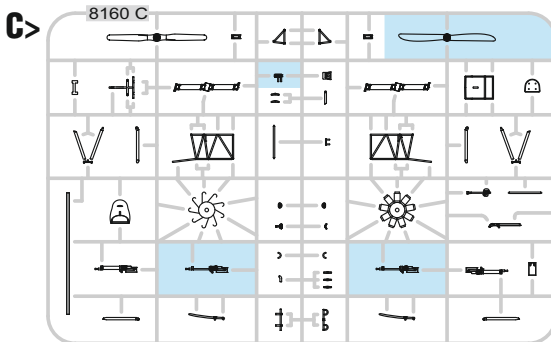
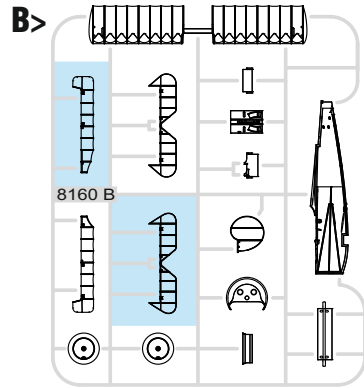
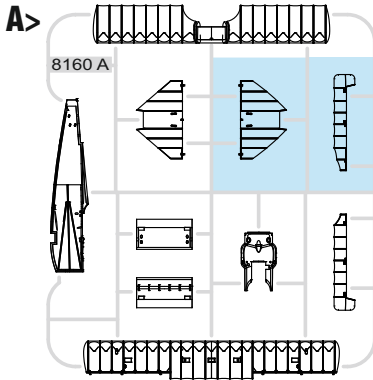

GUNZE	MISSION MODELS	
H3	C3	MMP-003 RED
H4	C4	MMM-007 YELLOW
H11	C62	MMP-001 FLAT WHITE
H12	C33	MMP-047 FLAT BLACK
H27	C44	TAN
H37	C43	WOOD BROWN
H47	C41	MMP-012 RED BROWN
H51	C11	MMP-063 LIGHT GULL GRAY
H52	C12	MMP-091 OLIVE DRAB
H70	C60	MMP-056 GRAY
	C74	MMP-061 AIR SUPERIORITY BLUE
METAL	METALLICS	
MC213	MMM-006	STEEL
MC214	MMM-001	DARK IRON
MC218	MMM-003	ALUMINIUM
MC219	MMM-009	BRASS

-Parts not for use. -Teile werden nicht verwendet. -Pièces à ne pas utiliser. -Tyto díly nepoužívejte při stavbě. - 使用しない部品

ATTENTION * UPOZORNĚNÍ * ACHTUNG * ATTENTION

(GB)

Carefully read instruction sheet before assembling. When you use glue or paint, do not use near open flame and use in well ventilated room. Keep out of reach of small children. Children must not be allowed to suck any part, or pull vinyl bag over the head.

(CZ)

Před započetím stavby si pečlivě prostudujte stavební návod. Při používání barev a lepidel pracujte v dobře větrané místnosti. Lepidla ani barvy nepoužívejte v blízkosti otevřeného ohně. Model není určen malým dětem, mohlo by dojít k požití drobných dílů.

(D)

Vor dem Zusammenbau die Bauanleitung gut durchlesen. Kleber und Farben nicht in der Nähe von offenem Feuer verwenden und für eine ausreichende Belüftung sorgen. Den Bausatz von kleinen Kindern fernhalten. Vermeiden Sie, dass Kinder Bauteile in den Mund nehmen oder sich Plastiktüten über den Kopf ziehen.

(F)

lire soigneusement la fiche d'instructions avant d'assembler. Ne pas utiliser de colle ou de peinture à proximité d'une flamme nue, et aérer la pièce de temps en temps. Garder hors de portée des enfants en bas âge. Ne pas laisser les enfants mettre en bouche ou sucer les pièces, ou passer un sachet vinyl sur la tête.

INSTRUCTION SIGNS * INSTR. SYMBOLY * INSTRUKTION SINNBILDEN * SYMBOLES

(?)
OPTIONAL
VOLBA

(↶)
BEND
OHNOU

(⊘)
SAND
BROUSIT

(⊘)
OPEN HOLE
VYVRTAT OTVOR

(↻)
SYMETRICAL ASSEMBLY
SYMETRICKÁ MONTÁŽ

(⊘)
REMOVE
ODRŮZNOUT

(↺)
REVERSE SIDE
OTOČIT

(★)
APPLY EDUARD MASK
AND PAINT
POUŽIT EDUARD MASK
NABARVIT

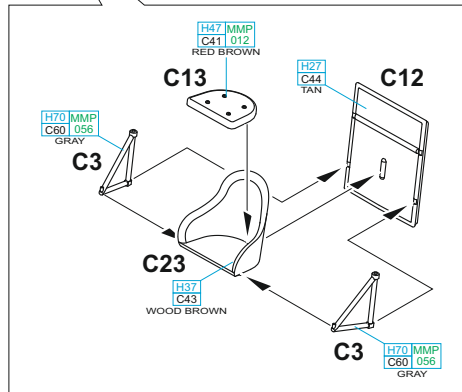
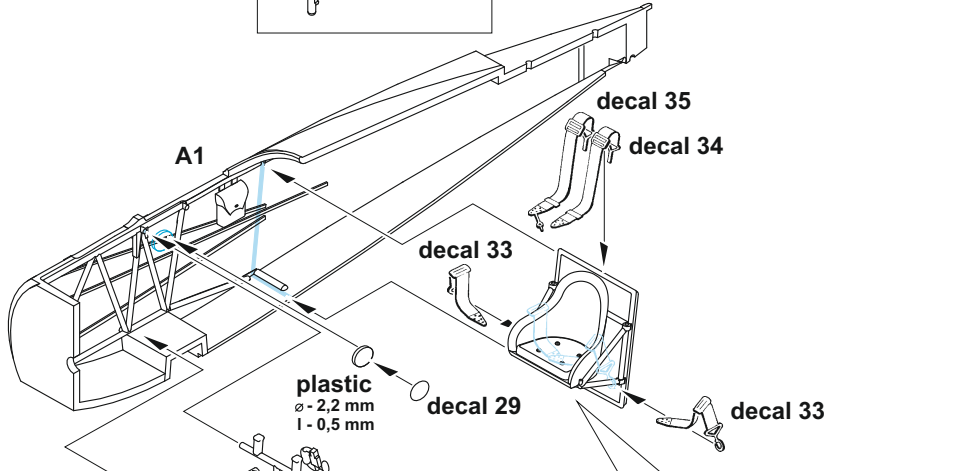
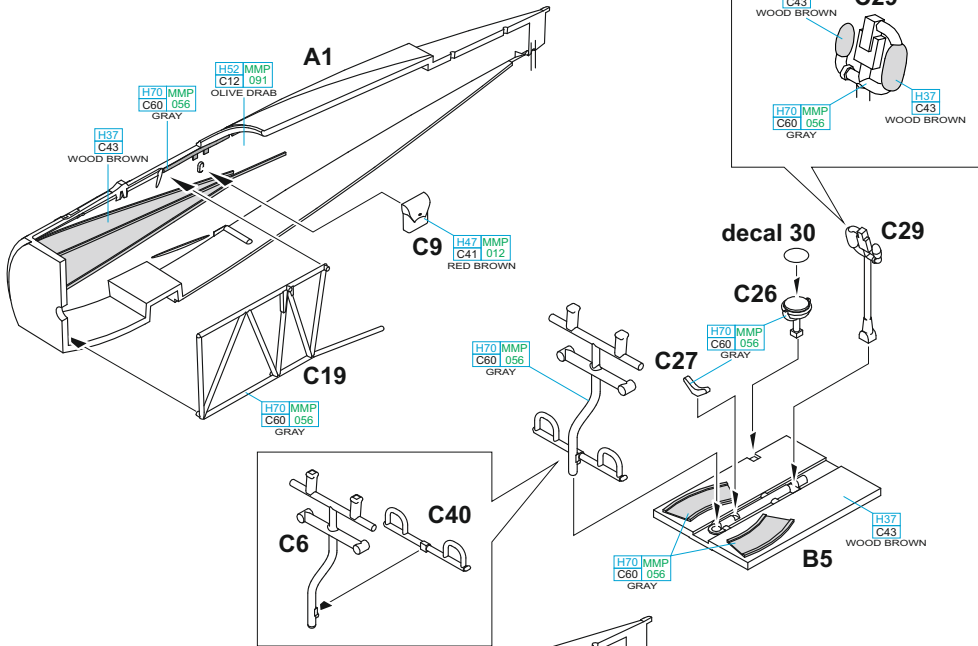

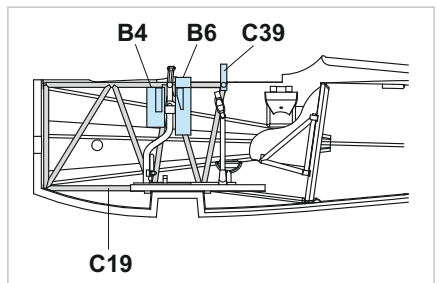
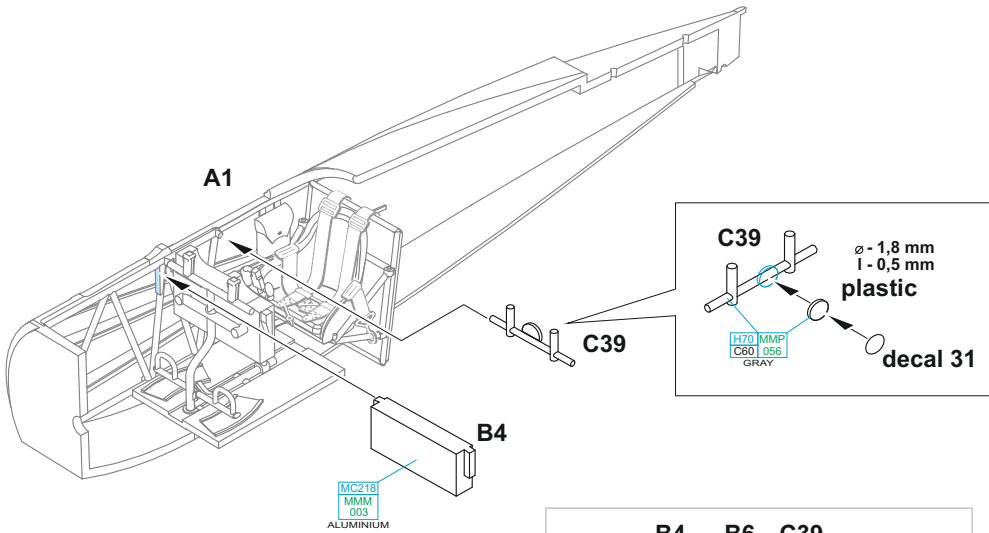
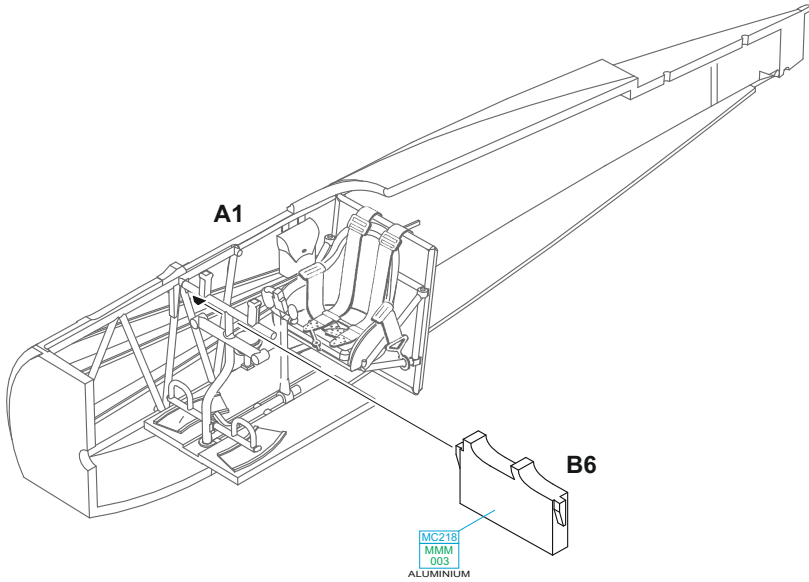

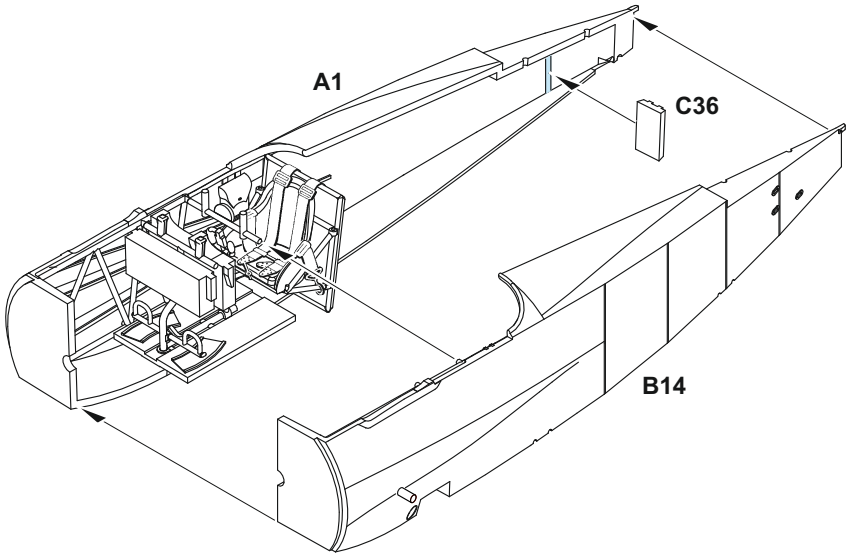
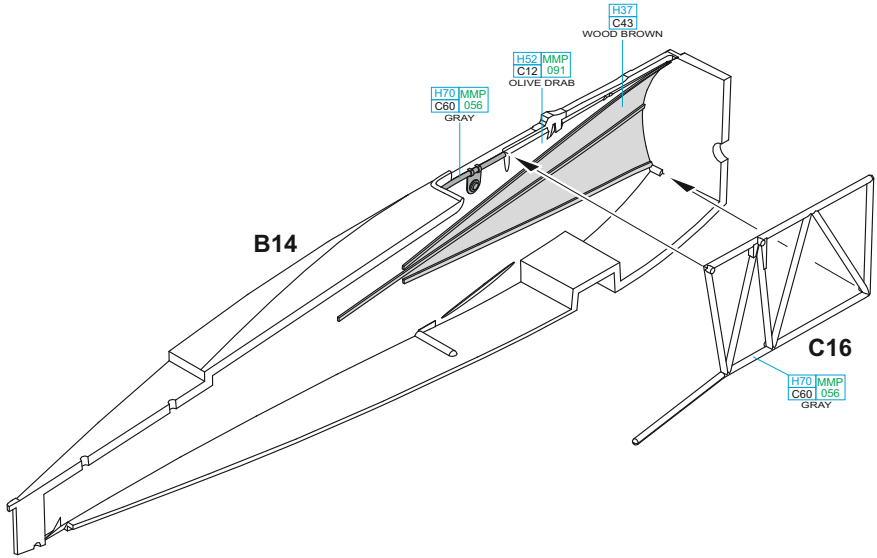

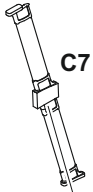

decal 32

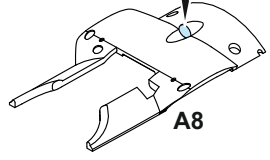

C25

C25

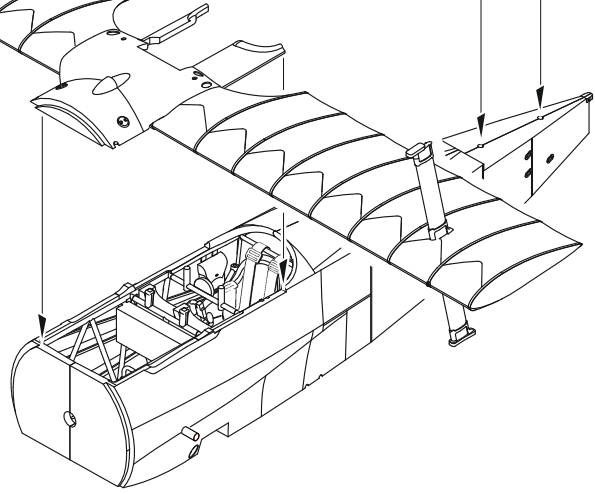
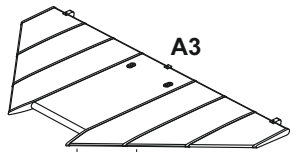
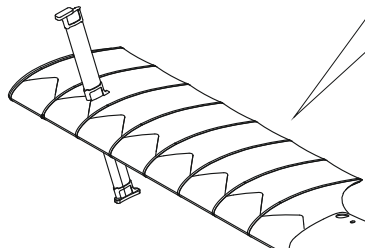
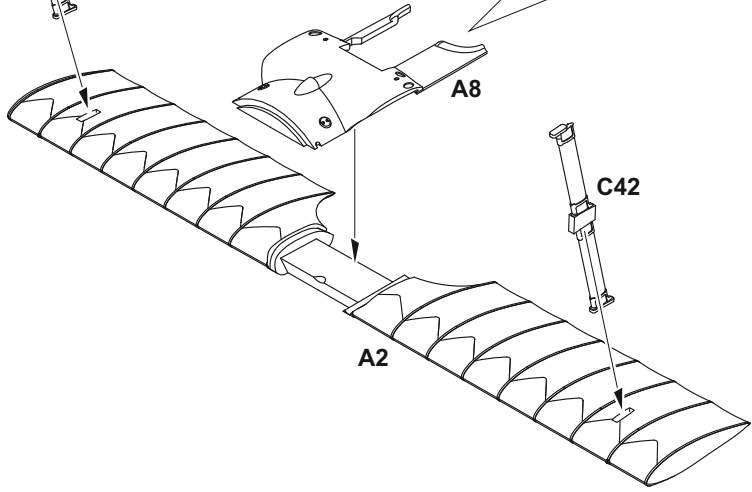
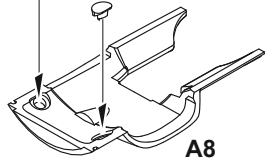

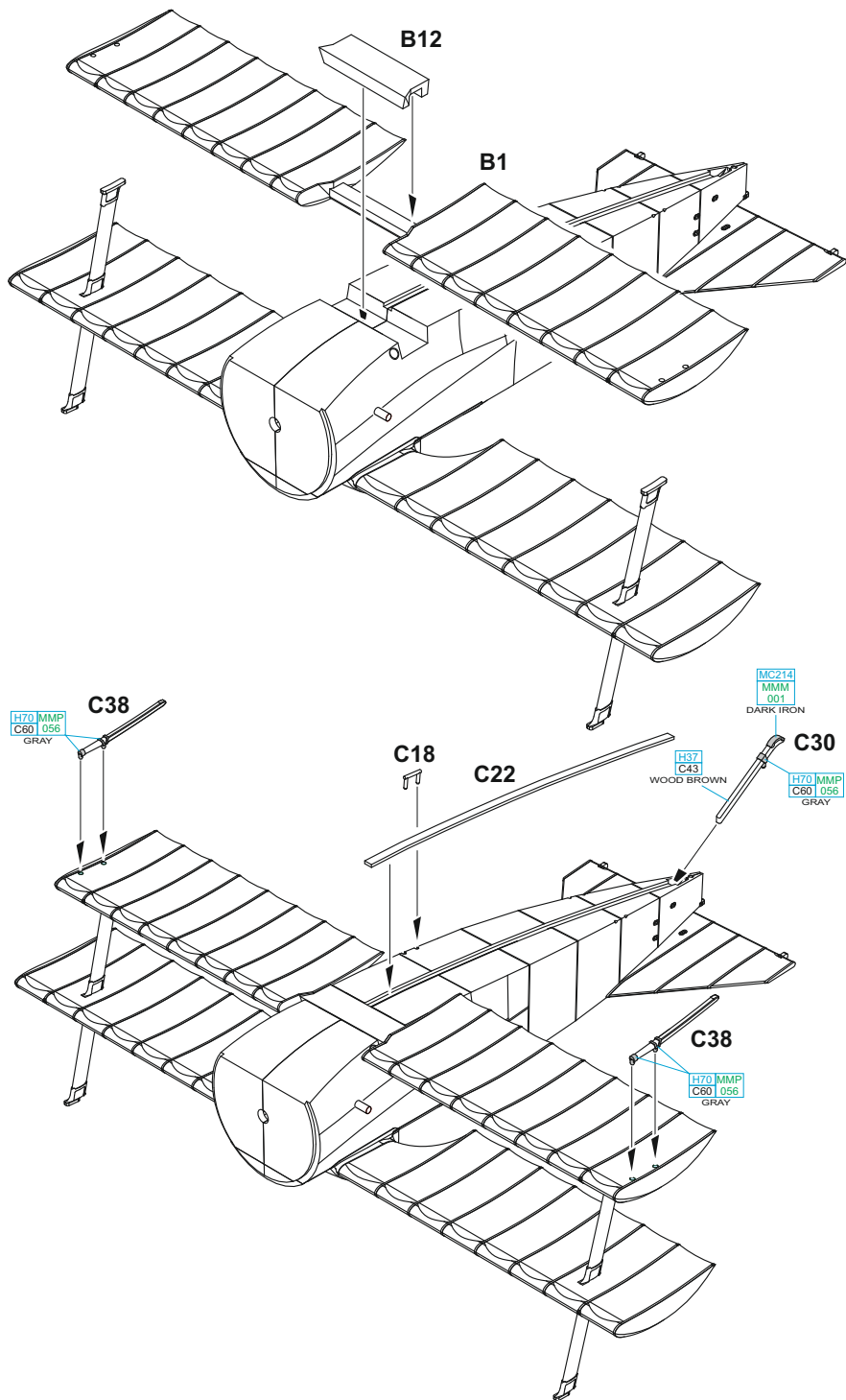

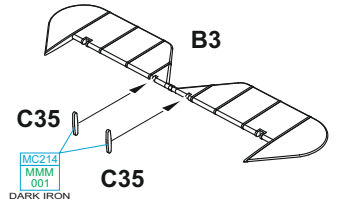
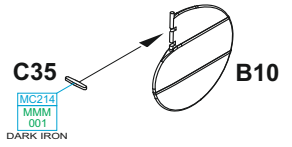
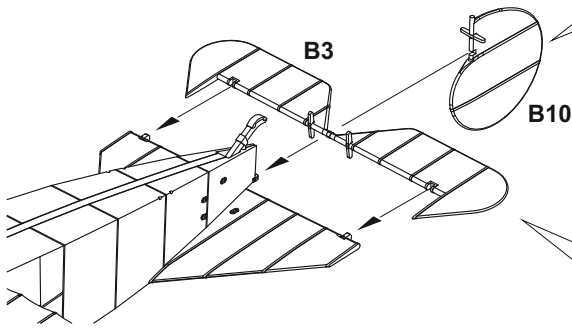

A

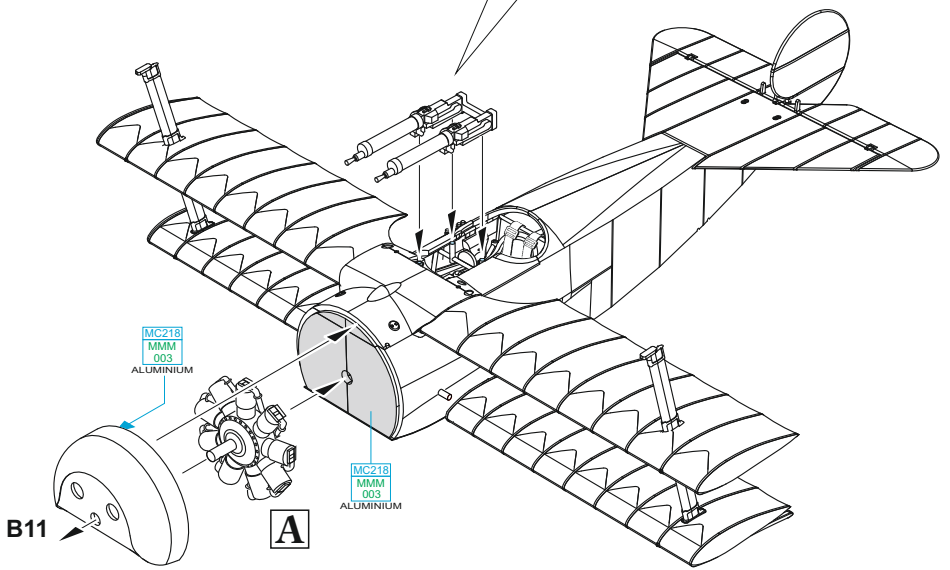
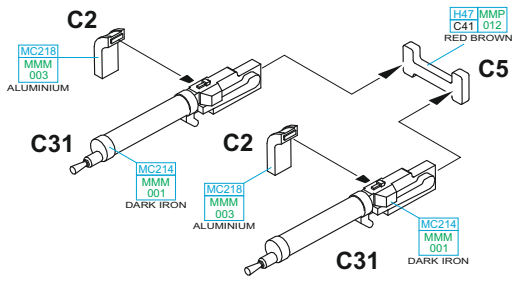
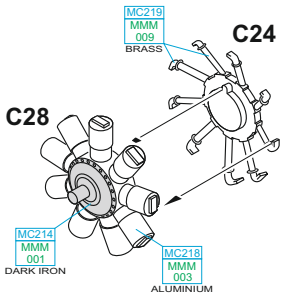

A

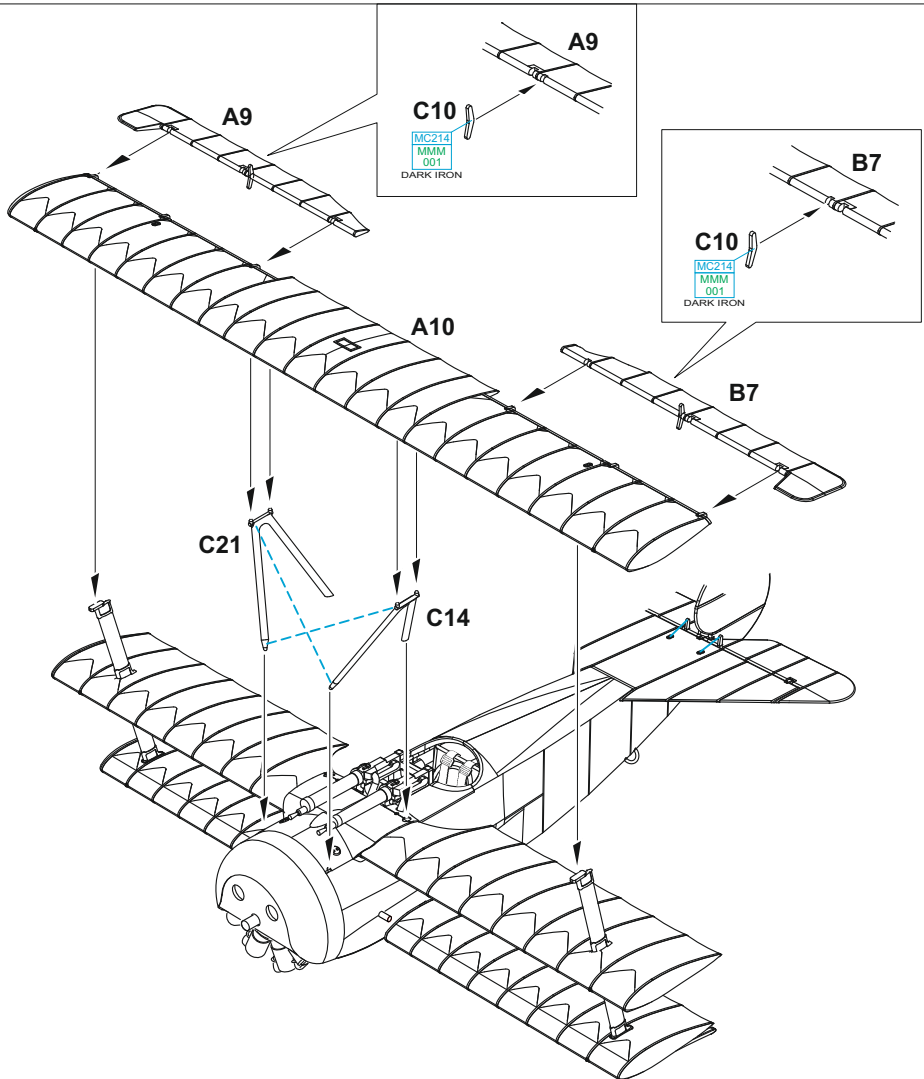
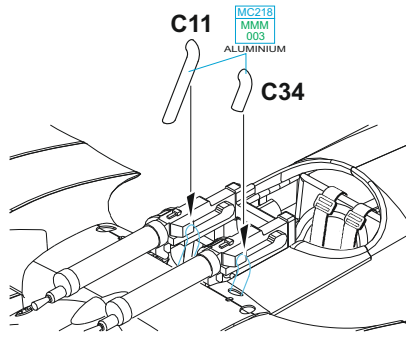

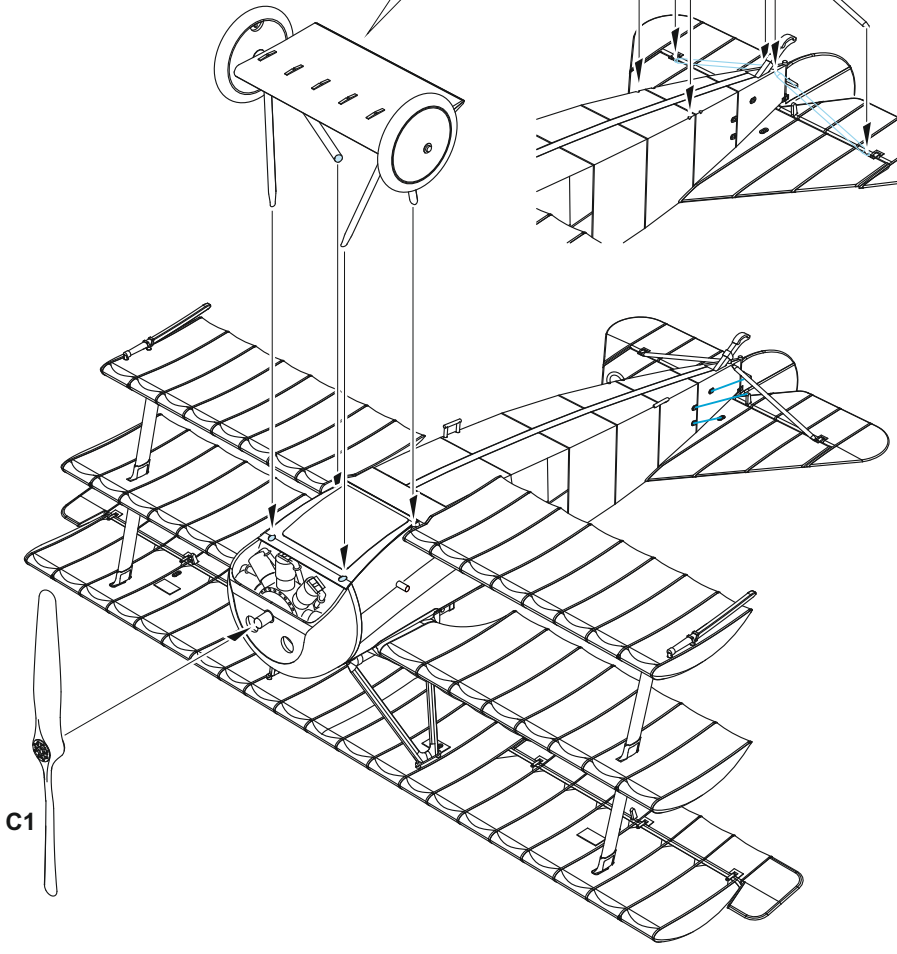
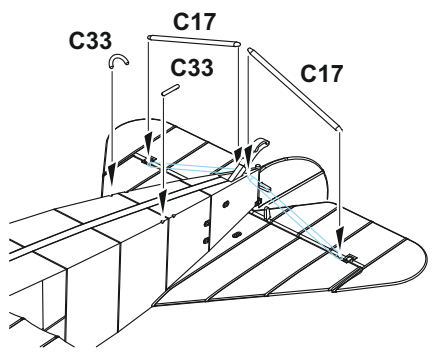
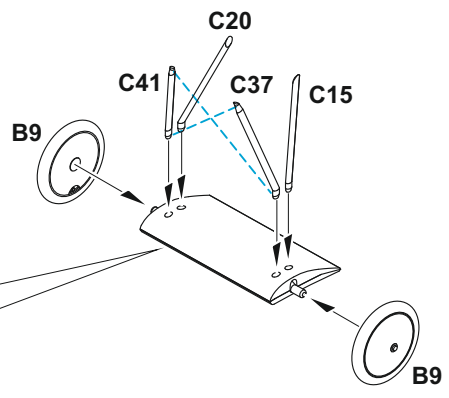
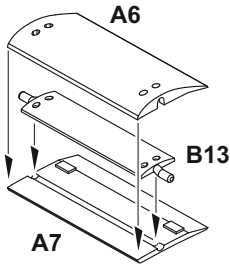

UNDERSURFACE OF THE WINGS

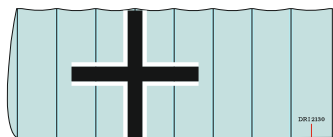

21736

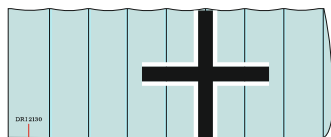

21736

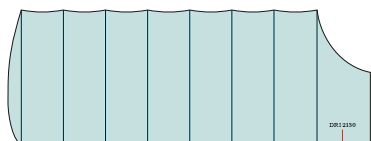

21736

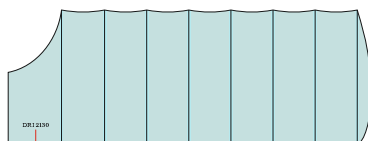

21736

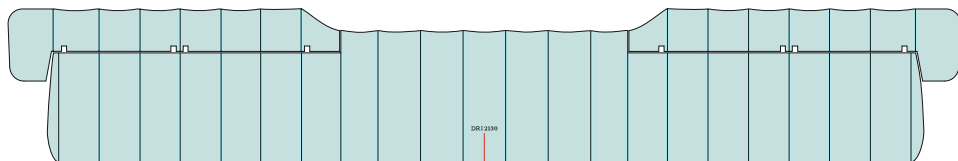

21736