



1:48 Supermarine Spitfire Mk.I

A05126 SCALE MODEL CONSTRUCTION KIT | Wingspan: 232mm Fuselage Length: 195mm | Three Decal Schemes Included | Two Build Options

GB

The Supermarine Spitfire is arguably both the most famous and most beautiful fighter aircraft ever to grace the skies. First flying in 1936, R. J. Mitchell's masterpiece was, by 1940, the interceptor of choice for Fighter Command, and the envy of many of the world's air arms. Powered by the equally famous Rolls Royce Merlin V12, the Spitfire was capable of speeds of over 360mph and had exceptional manoeuvrability. The Spitfire was an excellent dog-fighter, with its ability to turn inside an opponent a great strength in the struggles over southern England and the English Channel during the Battle of Britain in the summer of 1940. The Spitfire Mark I has come to be seen as a symbol of 'The Few', vital to the defence of the United Kingdom against the previously all-conquering Luftwaffe. Along with the Hurricane, it cemented its place in history during the Battle of Britain and continues now to be a hugely desirable 'warbird' at air shows.

Specification:

Speed: 367mph (591Km/h)
Range: 470m (760km)
Ceiling: 31,900 ft. (9,700 m)
Wingspan: 36 ft. 10 in (11.23 m)
Length: 29 ft. 11in (9.12 m)
Armament: 8 x .303in Browning machine guns

FR

Le Supermarine Spitfire est sans doute le chasseur le plus célèbre et le plus élégant de tous les temps. Après son premier vol en 1936, dès 1940 ce chef-œuvre de R.J.Mitchell était l'intercepteur préféré de Fighter Command tout en faisant envie à de nombreuses armées aériennes mondiales. Propulsé par le non moins célèbre moteur Merlin V12 de Rolls Royce, le Spitfire était capable de voler à plus de 576 km/h. Doté d'une manœuvrabilité exceptionnelle, il était un avion de combat par excellence grâce à sa capacité de faire des virages plus serrés que ceux d'un adversaire, un grand atout pour les combats au-dessus de la Manche dans lesquels il était tellement impliqué au cours de l'été de 1940. Le Spitfire Mk.I est considéré en tant que symbole des chasseurs de la RAF, essentiels pour la défense du Royaume-Uni contre la jusqu'alors toute-puissante Luftwaffe. Avec le Hurricane, il consolida sa place dans l'histoire pendant la bataille d'Angleterre et reste toujours aujourd'hui un avion de combat énormément populaire lors des salons aéronautiques.

Spécification:

Vitesse : 591 km/h
Autonomie : 760 km
Plafond pratique : 9,700 m
Envergure : 11,23 m
Longueur : 9,12 m
Armement : huit mitrailleuses Browning de 7,7 mm.

DE

Die Supermarine Spitfire wird von vielen als bekanntestes und formschönstes Jagdflugzeug aller Zeiten angesehen. Nachdem sie 1936 erstmals vom Boden abgehoben hatte, war das Meisterstück seines Konstrukteurs R. J. Mitchells bis 1940 zum Abfangjäger der Wahl für das Fighter Command geworden, wovon viele Luftstreitkräfte der Welt die RAF beneideten. Vom ebenso bekannten Rolls Royce Merlin V12 Motor angetrieben, konnte die Spitfire Geschwindigkeiten von über 590 km/h erreichen. Dazu noch zeichnete sie sich durch äußerst hohe Wendigkeit aus. Die Spitfire bewährte sich ganz besonders in harten Luftgefechten. Mit ihrer Fähigkeit, in einer engeren Kurve als ihre Gegner abzudrehen, konnte sie bei den intensiven Luftkämpfen über dem Ärmelkanal im Sommer 1940 oft einen entscheidenden Vorteil erringen. Die Mark I Spitfire wird in Großbritannien vielfach als Symbol für eine zahlenmäßig relativ kleine Schar von Verteidigern angesehen, die das Land vor einer Einnahme durch die zuvor stets erfolgreiche Luftwaffe bewahrte. Zusammen mit der Hurricane festigte sie in der Luftschlacht um England ihren Platz in der Kriegsgeschichte und erweist sich bei Flugschauen immer wieder als großer Publikumsmagnet.

Spezifikation:

Geschwindigkeit: 591 km/h
Reichweite: 760 km
Gipfelhöhe: 9,700 m
Spannweite: 11,23 m
Länge: 9,12 m
Bewaffnung: acht 7,7 mm Browning MG.

ES

El Supermarine Spitfire es, posiblemente, el caza más famoso y hermoso que jamás haya surcado los cielos. Tras su primer vuelo en 1936, la obra maestra de R. J. Mitchells fue el interceptador elegido en 1940, para el Mando de Cazas, y se convertiría en la envidia de muchos ejércitos aéreos. Impulsado por el no menos famoso Rolls Royce Merlin V12, el Spitfire alcanzaba velocidades de más de 590 km/h, además de ofrecer una excepcional maniobrabilidad. El Spitfire era un avión de combate por excelencia gracias a su capacidad para valverse contra el adversario, un factor de gran importancia en los numerosos enfrentamientos en los que participó sobre el Canal de la Mancha en el verano de 1940. El Mark I Spitfire se recuerda como símbolo de la defensa del Reino Unido contra la Luftwaffe, hasta entonces absolutamente imparable. Al igual que el Hurricane, se ganó su lugar en la historia durante la Batalla de Inglaterra y sigue siendo en la actualidad uno de los más admirados aparatos en las exhibiciones aéreas.

Especificación:

Velocidad: 591 km/h
Autonomía: 760 km
Techo de vuelo: 9,700 m
Envergadura: 11,23 m
Longitud: 9,12 m
Armamento: 8 ametralladoras Browning de 7,7mm.

SE

Supermarine Spitfire är ett av de mest berömda och vackraste jaktplan som någonsin har skådats på himlen. R. J. Mitchells mästerverk flögs för första gången 1936 och blev 1940 Fighter Commands viktigaste jaktplan, något som väckte avund bland den övriga världens flygvapen. Spitfire, som drevs av den lika välkända Rolls Royce Merlin V12-motorn, nådde hastigheter över 590 km/h och var mycket manövrerbar. Spitfire briljerade under luftdueller tack vare dess korta vändradie, en egenskap som visade sig mycket användbar i strider över Engelska kanalen under sommaren 1940. Mark I Spitfire ansågs utgöra en symbol för, och vital del av, försvaret av Storbritannien och Nordirland mot det tidigare så överlägsna Luftwaffe. Tillsammans med Hurricane befäste planet sin plats i historien under Slaget om Storbritannien och fortsätter att imponera vid flyguppvisningar.

Specifikation:

Hastighet: 591 km/h
Räckvidd: 760 km
Tjänstetak: 9,700 m
Spännvidd: 11,23 m
Längd: 9,12 m
Bestyckning: 8 st. 7,7 mm Browning-kulsprutor.

FOR BEST RESULTS:

Surfaces to be painted should be clean – before parts are removed from the sprue, wash in warm, soapy water, rinse and dry thoroughly. Stir paints thoroughly before use.

PLEASE NOTE:

Some parts in the kit may not be required to build the model specified.

**HORNBY
HOBBIES**



ASSEMBLY INSTRUCTIONS

GB Study drawings and practice assembly before cementing parts together. Carefully scrape plating and paint from cementing surfaces. All parts are numbered. Paint small parts before assembly. To apply decals cut sheet as required, dip in warm water for a few seconds, slide off backing into position shown. Use in conjunction with box artwork. Not appropriate for children under 36 months of age, due to the presence of small detachable parts.

FR Étudier attentivement les dessins et simuler l'assemblage avant de coller les pièces. Gratter soigneusement tout revêtement ou peinture sur les surfaces à coller avant collage. Toutes les pièces sont numérotées. Peindre les petites pièces avant l'assemblage. Pour coller les décalques, découper le motif, le plonger quelques secondes dans de l'eau chaude puis le poser à l'endroit indiqué en décollant le support papier. Utiliser en même temps les illustrations sur la boîte. Ne convient pas à un enfant de moins de 36 mois – présence de petits éléments détachables.

DE Vor Verwendung des Klebers Zeichnungen studieren und Zusammenbau üben. Farbe und Plattierung vorsichtig von den Klebeflächen abkratzen. Alle Teile sind nummeriert. Vor Zusammenbau kleine Teile anmalen. Um die Abziehbilder aufzukleben, diese ausschneiden, kurz in warmes Wasser tauchen, dann abziehen und wie abgebildet aufkleben. In Verbindung mit Abbildungen auf Schachtel verwenden. Ungeeignet für Kinder unter 36 Monaten. Kleine Teilchen vorhanden die sich lösen können.

ES Estudiar los dibujos y practicar el montaje antes de pegar las piezas. Raspar cuidadosamente el plateado y la pintura en las superficies de contacto antes de pegar las piezas. Todas las piezas están numeradas. Es conveniente pintar las piezas pequeñas antes de su montaje. Para aplicar las calcomanías, cortar la hoja, sumergir en agua tibia durante unos segundos y deslizarlas en la posición debida. Ver ilustraciones en la caja. No conviene a un niño menor de 36 meses, contiene pequeñas piezas que pueden soltarse.

SE Studera bilderna noggrant och sätt ihop delarna innan du limmar ihop dem. Skrapa noggrant bort förtromning och färg från limmade delar. Alla delarna är numrerade. Mala smadelarna före ihopsättning. Fastsättning av dekaler, klipp arket. Doppa i varmt vatten några sekunder, låt baksidan glida på plats som bilden visar. Används i samband med kartongens handlitografi. Rekommenderas ej för barn under 3 år. Innehåller löstagbara smadelar.

IT Studiare i disegni e praticare il montaggio prima di unire insieme i pezzi con l'adesivo. Raschiare attentamente le tracce di smalto e cromatura dalle superfici da unire con adesivo. Tutti i pezzi sono numerati. Colorare i pezzi di piccole dimensioni prima di montarli. Per applicare le decalcomanie, tagliare il foglio secondo il caso, immergere in acqua calda per alcuni secondi, quindi sfilare la decalcomania dalla carta di supporto e piazzarla nella posizione indicata. Usare in congiunzione con l'illustrazione sulla scatola. Non adatto ad un bambino di età inferiore ai 36 mesi dovuto alla presenza di piccoli elementi staccabili.

NL Tekeningen bestuderen en delen in elkaar zetten alvorens deze te lijmen. Metaalcoating en lak voorzichtig van lijmvlakken af schrapen. Alle delen zijn genummerd. Kleine delen vóór montage verven. Voor aanbrengen van stickers, gewenste stickers uit vel knippen, een paar seconden in warm water dompelen en dan van schutblad af op afgebeelde plaats schuiven. Hierbij afbeelding op doos raadplegen. Niet geschikt voor kinderen onder 3 jaar, omdat kleine deeltjes gemakkelijk kunnen losraken.

DK Tegningerne bør studeres, og man bør øve sig i monteringen, før delene limes sammen. Pladestykker og maling skal omhyggeligt fjernes fra kloebeoverfladerne. Alle dele er nummererede. Små dele skal males før monteringen. Overføringsbillederne anvendes ved at tilklippe arket efter behov. Og dyppe det i varmt vand i nogle få sekunder. Underlaget glides af og anbringes i den viste position. Påføres ifølge brugsanvisningerne på oesken. Ikke til børn under 3 år, forekomst af små løse elementer.

PT Estudar atentamente os desenhos e experimentar a montagem. Raspar cuidadosamente as superfícies de modo a eliminar pintura e revestimento antes de colar. Todas as peças estão numeradas. Pintar as pequenas peças antes de colar. Para aplicar as decalcomanias, cortar as folhas e mergulhar em água morna por alguns segundos, depois deslizar e aplicar no respectivo lugar, como indicado nas ilustrações na caixa. Não convém a uma criança de menos de 36 meses devido à presença de pequenos elementos destacáveis.

FI Tutustu piirroksiin ja harjoittele kokoamista ennen kuin liimaat osat yhteen. Raaputa metallipäällyste ja maali varovasti pois liimattavilta pinnoilta. Kaikki osat on numeroitu. Maalaa pienet osat ennen kokoamista. Siirtokuvien kiinnittämiseksi leikkaa ne arkista tarpeen mukaan. Kasta kuva lämpimään veteen muutaman sekunnin ajaksi, anna takapuolen liukua kuvalle osoitettuun kohtaan. Käytetään yhdessä laatikon kuvituksen kanssa. Ei suositella alle kolmivuotiaalle lapsille. Paljon irrotettavia pikkuosia.

PL Przed przystąpieniem do sklejania przestuduj uważnie rysunki i przećwicz składanie części. Osłóźnie zeszkrob ze sklepanych powierzchni powłokę i farbę. Wszystkie części są ponumerowane. Drobne części pomaluj przed ich złożeniem. Celem przeniesienia odbitki wytnij ją z arkusza, zanurz na kilka sekund w letniej wodzie i zsuń z podłoża na wymagane miejsce. Używaj w połączeniu ze wzorami na pudełku. W związku z obecnością wielu drobnych, rozbiernych części, niestosowne dla dzieci poniżej 3 lat.

GR Μελετήστε προσεκτικά τα σχέδια και συναρμολογήστε για πρώτη φορά τα κομμάτια χωρίς να τα συγκολλήσετε. Αφαιρέσετε επιμελώς τη μεταλλική μπόγια και την πλαστική βαφή από τις επιφάνειες τις οποίες θα συγκολλήσετε ζύνοντάς τες προσεκτικά. Όλα τα κομμάτια είναι αριθμημένα. Χρωματίστε τα μικρά κομμάτια πριν από τη συναρμολόγηση. Για να κολλήσετε τις χαλκομανίες, κόψετε γύρω από το σχέδιο όπως απαιτείται, βυθίστε το μερικά δευτερόλεπτα σε χλιαρό νερό και μετά τοποθετήστε το στη θέση που υποδεικνύεται, αφαιρώντας τη μεμβράνη που το καλύπτει. Λάβετε υπόψη σας ταυτόχρονα την εικονογράφηση του κουτιού. Ακατάλληλο για παιδιά ηλικίας κάτω των 36 μηνών λόγω ύπαρξης μικρών κομματιών που αποσπώνται.

ASSEMBLY ICON INSTRUCTIONS

Assembly phase
Phase de montage
Montagephase
Fase de montaje
Monteringsfasen
Fase di montaggio
Montagefase
Fase de montagem
Monteringsfase
Kokoamisvaihe
Faza składania
Φάση συναρμολόγησης

Cement
Coller
Kleben
Pegar
Limma
Incollare
Lijmen
Colar
Klæbes
Limmaa
Kleić
Συγκολλήστε

Do not cement together
No pas coller
Nicht kleben
No pegar
Limma inte
Non incollare
Niet lijmen
Não colar
Skal ikke klæbes
Älä limmaa
Nie kleić
Μη συγκολλήσετε

Indicates final location
Indique l'emplacement final
Zeigt Endposition
Indica la ubicación definitiva
Anger slutmonteringsplats
Sede di montaggio finale
Geeft uiteindelijke locatie aan
Indica localização final
Viser endelig placering
Osoittaa lopullisen sijainnin
Oznacza miejsce docelowe
Υποδεικνύει τελική τοποθεσία

Alternativo part(s) provided
Autre(s) pièce(s) fournie(s)
Ersatzteil(e) mitgeliefert
Se incluye(n) pieza(s) alternativa(s)
Alternativ(a) del(ar) ingår
Uno o più componenti alternativi forniti
Alternatieve onderdelen meegeleverd
Peça(s) alternativa(s) fornecida(s)
Alternativ(e) del(e) medfølger
Vaihtoehtoiset osat pakkauskassa
Dostępnne części zamiennne
Παρέχονται εναλλακτικά κομμάτια

Repeat this operation
Répéter l'opération
Vorgang wiederholen
Repelir la operación
Upprepa åtgärden
Ripetere l'operazione
De verrichting herhalen
Repetir a operação
Manevren gentages
Toista toimenpide
Powtórzyc operację
Επανάλαβετε τη διαδικασία

Decals
Décalcomanias
Abziehbild
Calcomanias
Dekaler
Decalcomanie
Stickers
Decalcomania
Bildöverföring
Siirtokuvat
Kalkomanie
Χαλκομανίες

Crystal part
Pièce cristal
Kristallteil
Pieza de cristal
Kristalldel
Pezzo cristallo
Kristallen onderdeel
Peça de cristal
Krystallslykke
Kristalliosa
Część kryształowa
Κομμάτι κρυστάλλου

Weight
Lester
Beschweren
Lastrar
Belasta
Applicare un peso
Verzwaren
Lastrar
Påfer vægt
Aseta vastapaino
Obciążyc balastem
Επιβέστε βάρος

Remove by filing
Enlever avec une lime
Abfeilen
Eliminar con lima
Ta bort genom att fila
Rimuovere con la lima
Verwijderen door afvijlen
Remove limando
Fjern ved at file væk
Poista viilaamalla
Usunąć przy użyciu pilnika
Αφαιρέστε λιμάροντας με λίμα

Drill or pierce
Percer
Durchbohren
Perforar
Borra
Trapanare o forare
Boren of doorboren
Furar
Gennembor
Poraa tai puhkaise
Wywierć lub przedziurawić
Τρυπήστε

Cut
Découper
Schneiden
Cortar
Skär
Tagliare
Snijden
Cortar
Skær
Leikkaa
Przeciąć
Κόψτε

Humbrol paint number
No peinture Humbrol
Humbrol-Farbennummer
No de pintura Humbrol
Humbrol färg nummer
No vernice Humbrol
Humbrol verfnnummer
No de pintura Humbrol
Humbrol malingnummer
Humbrol-maalin numero
Nr farby Humbrol
Νούμερο χρώματος Humbrol

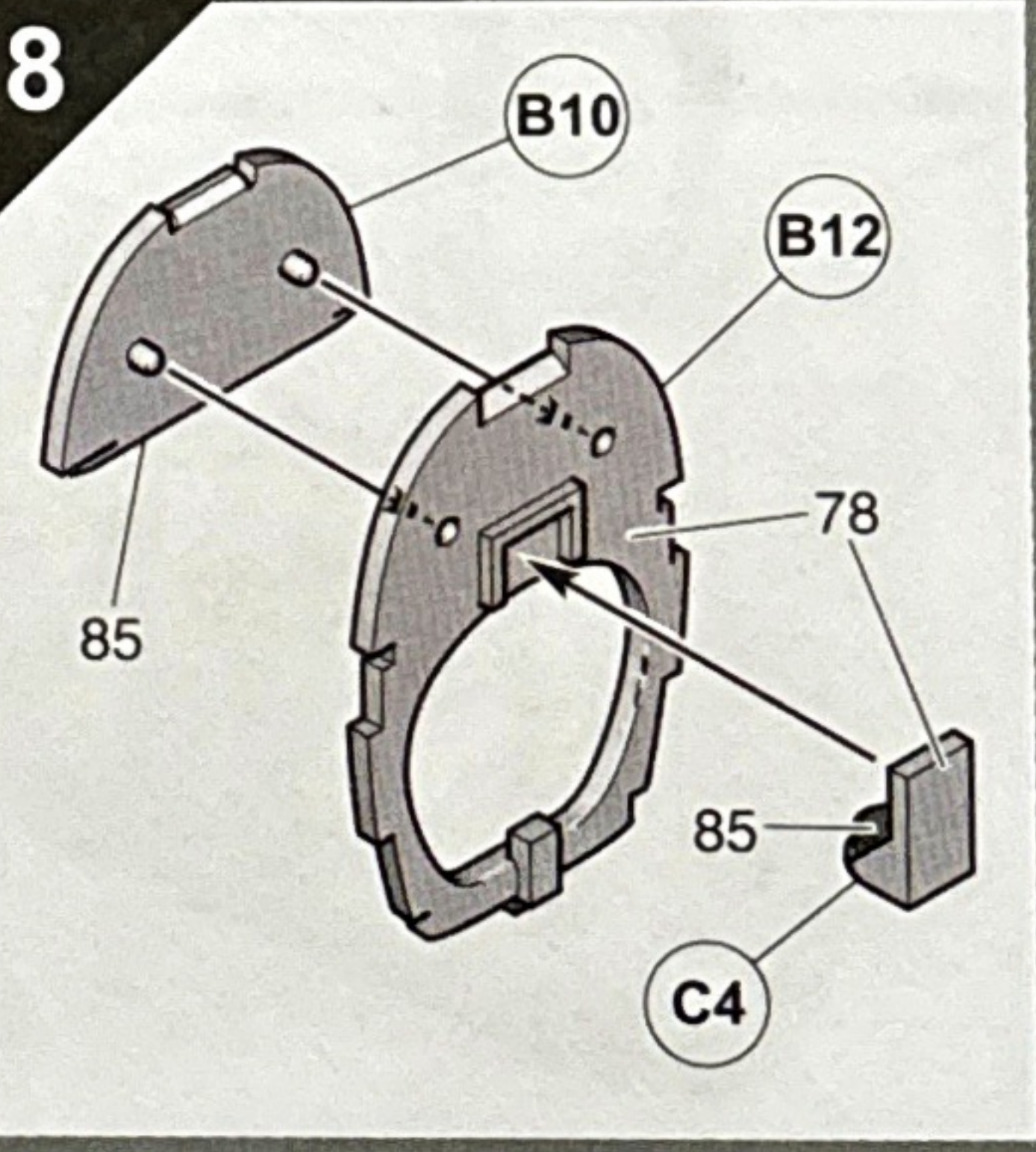
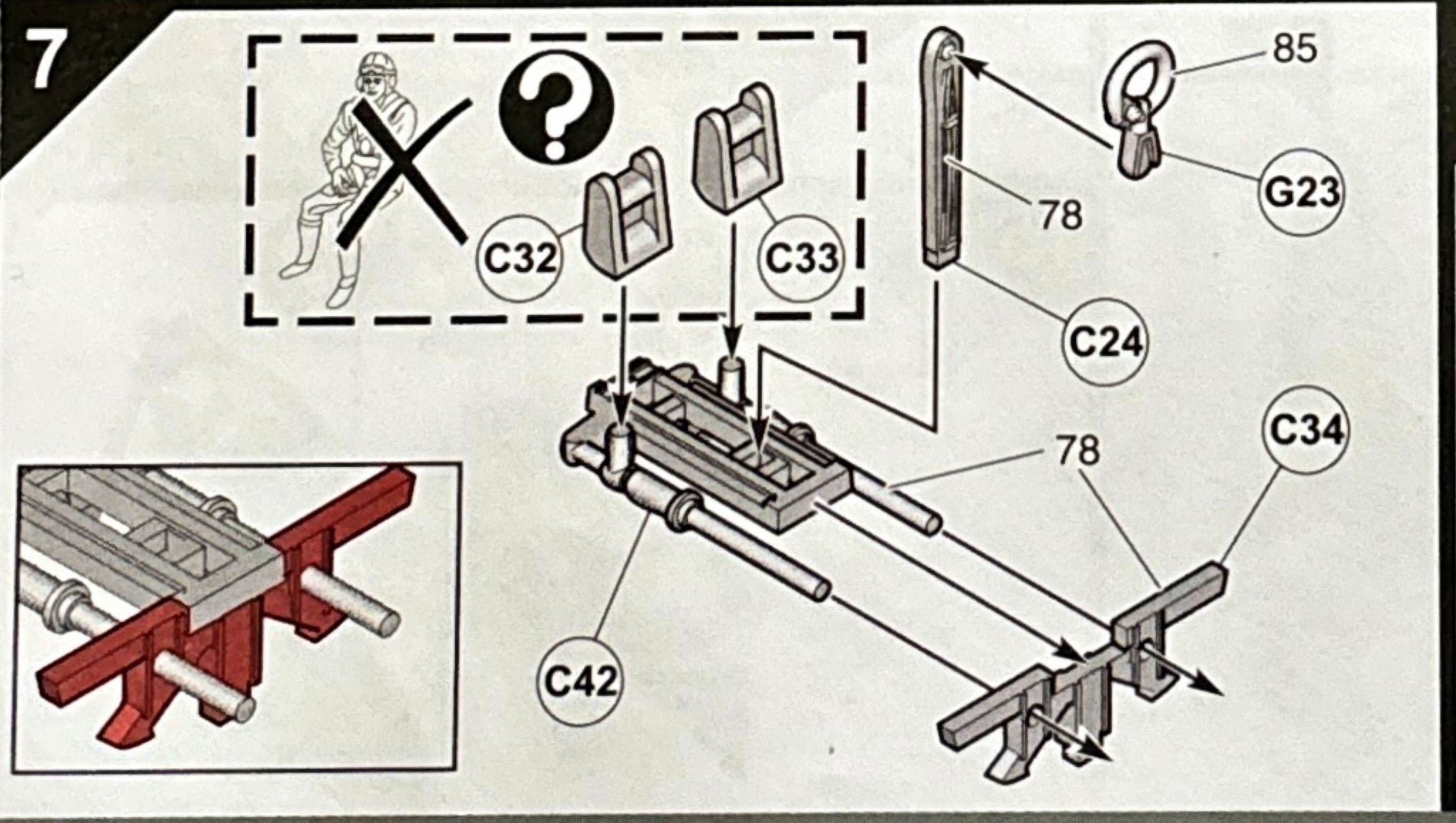
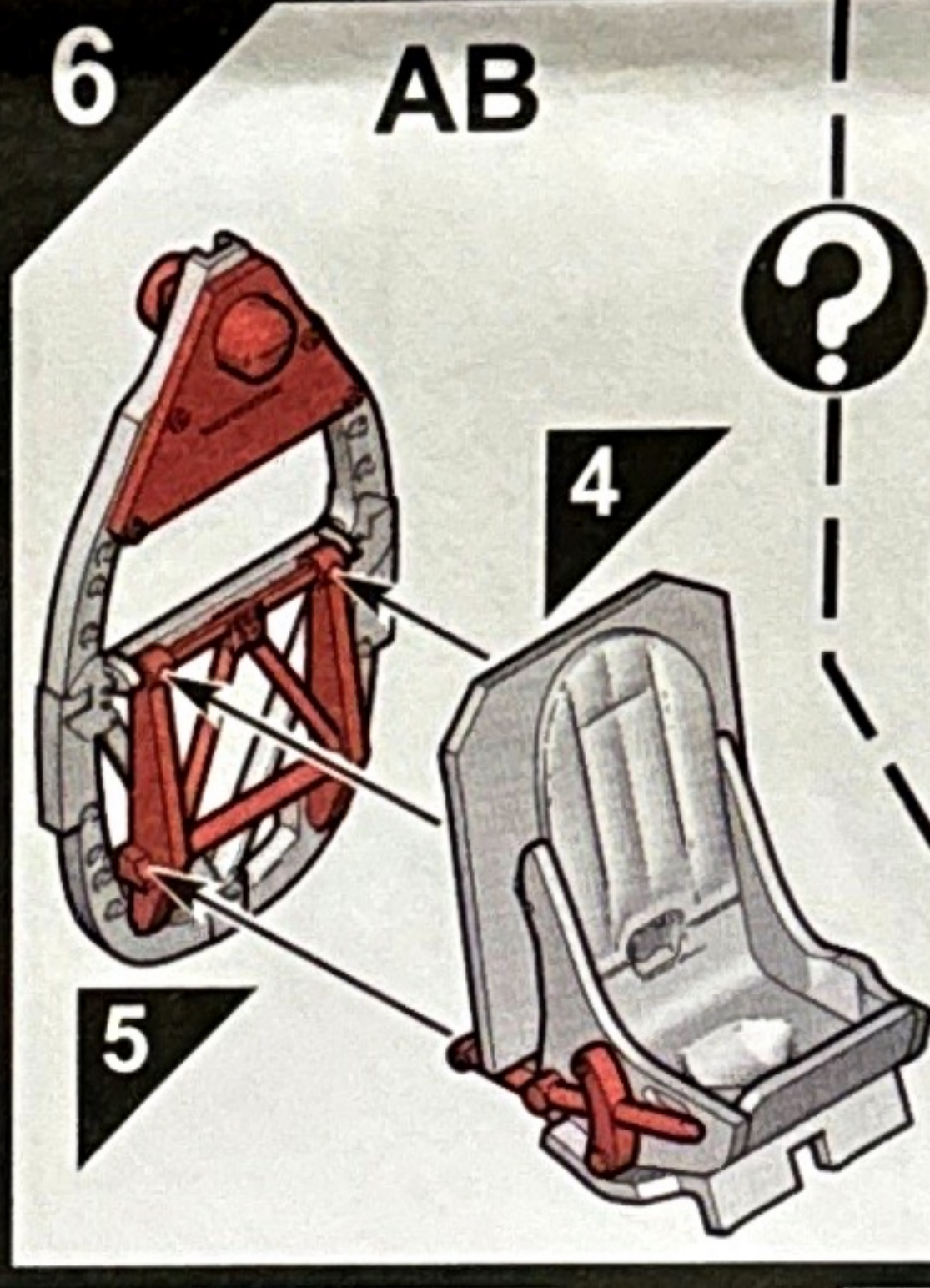
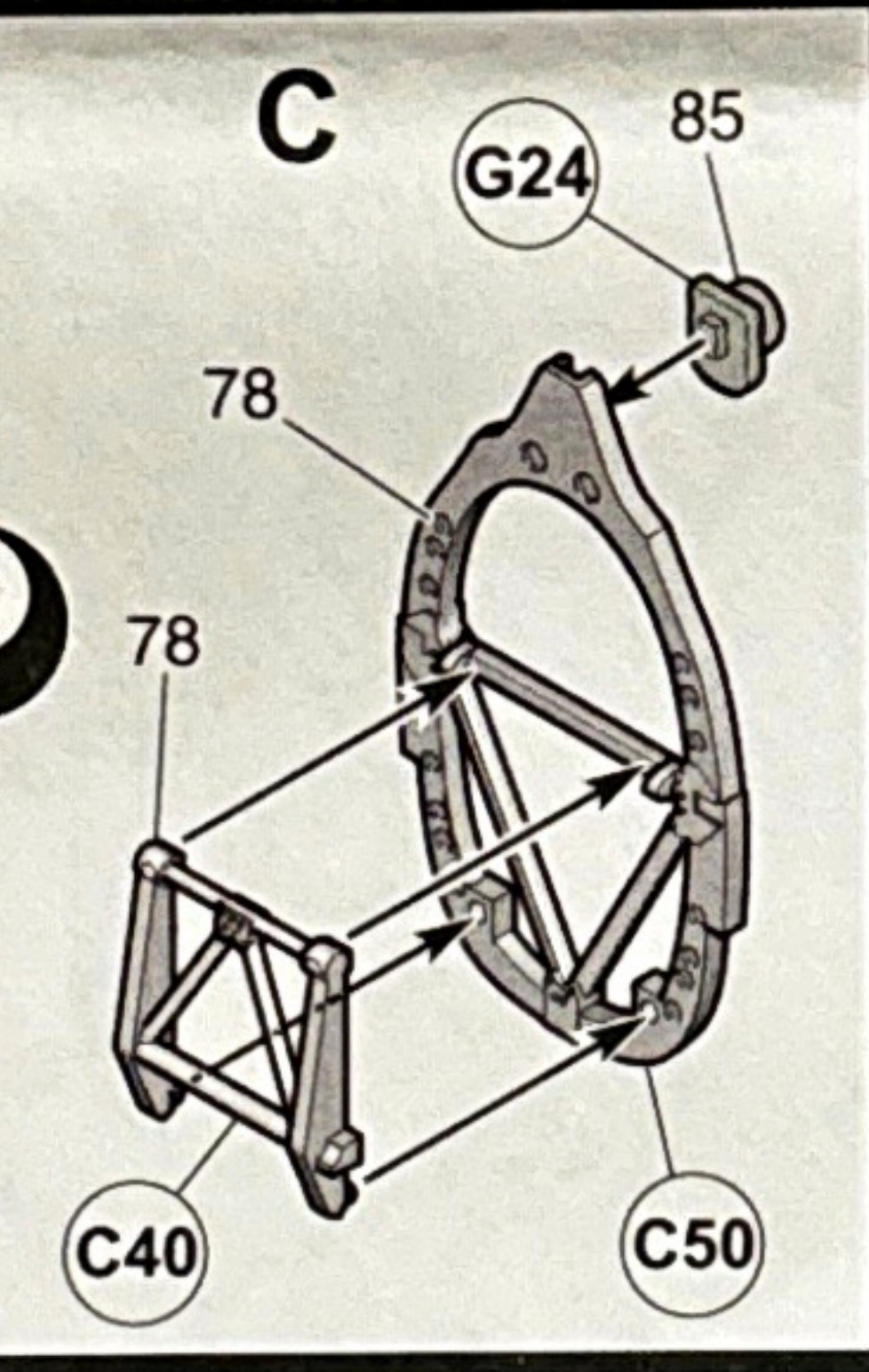
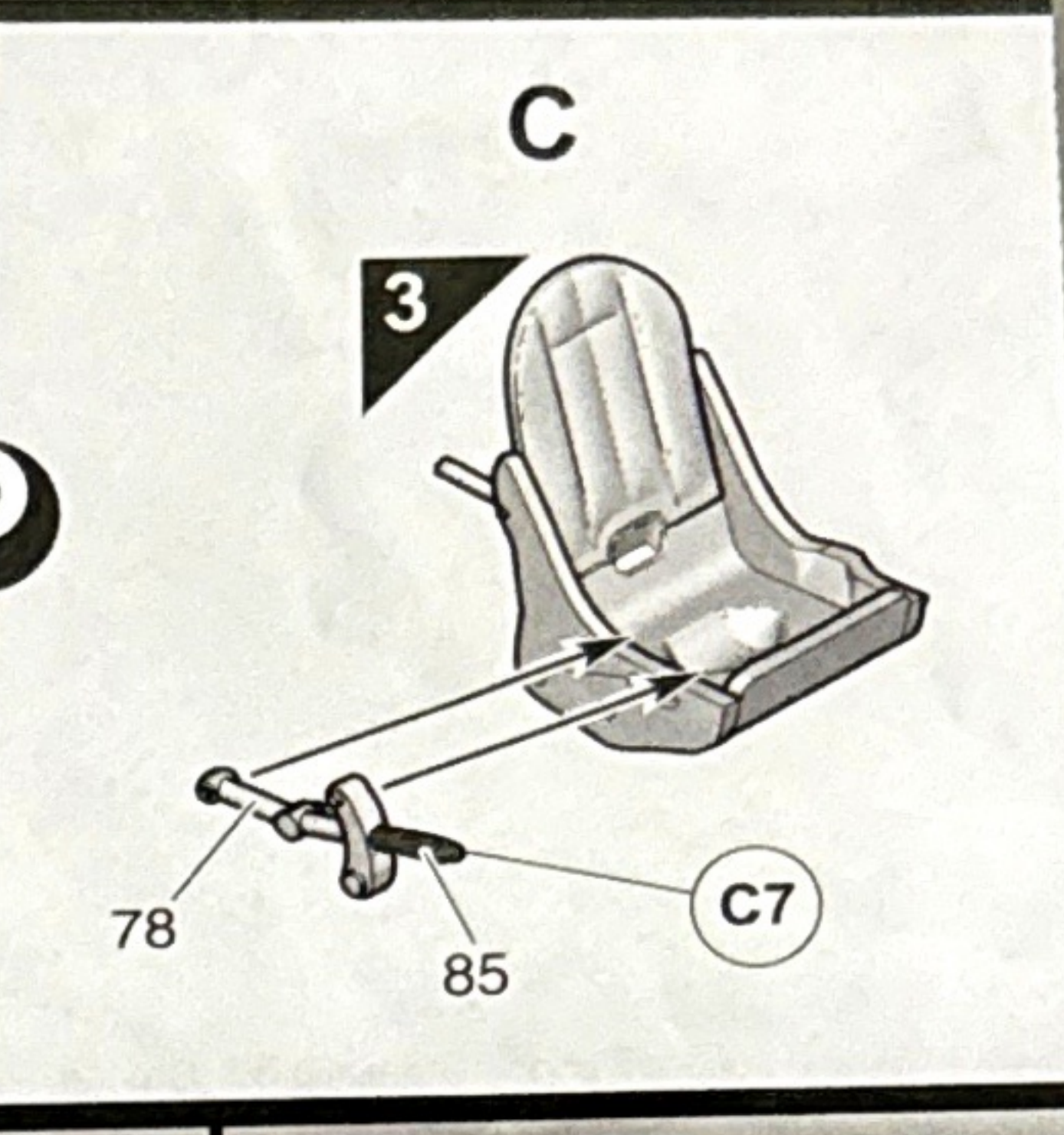
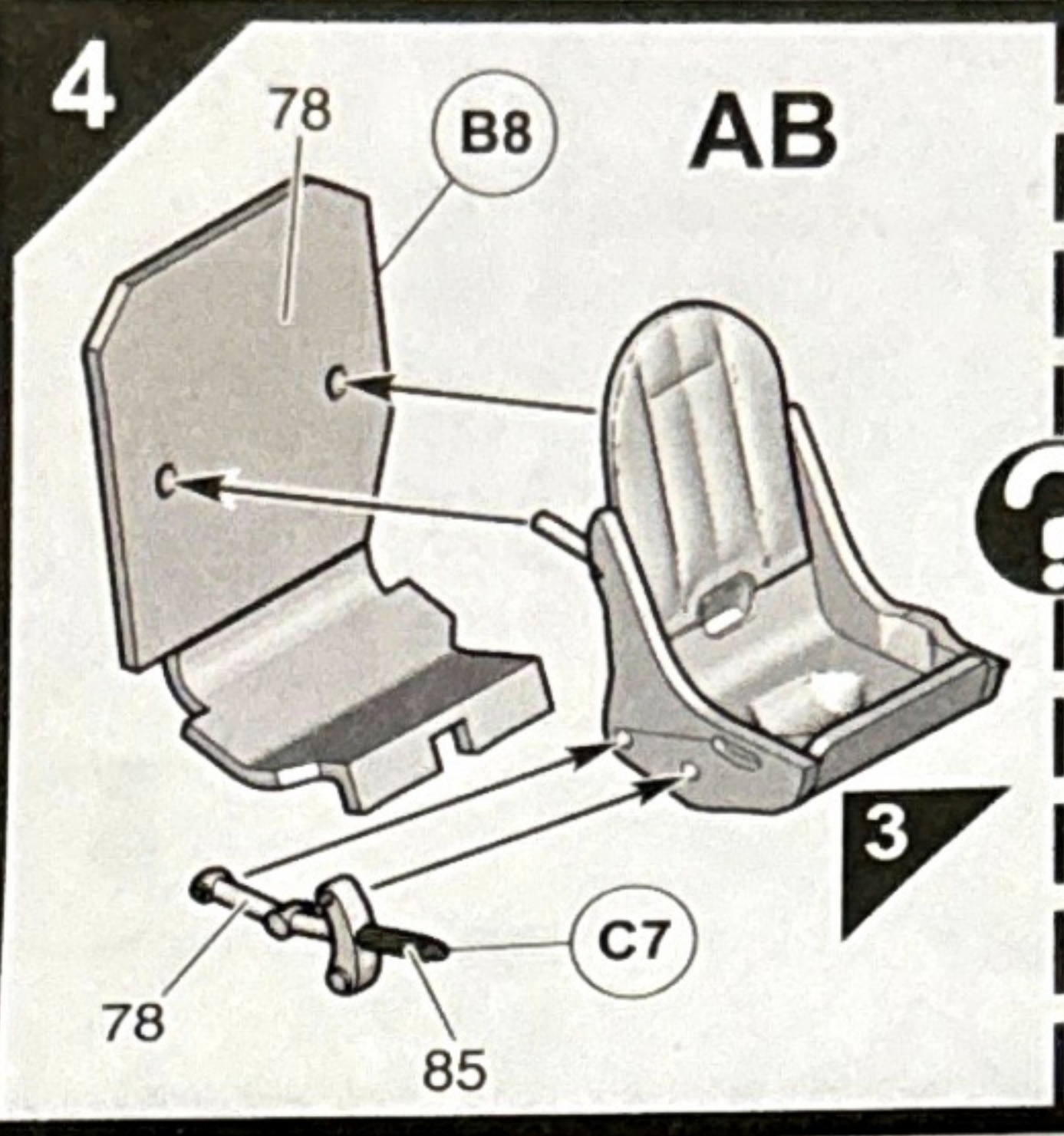
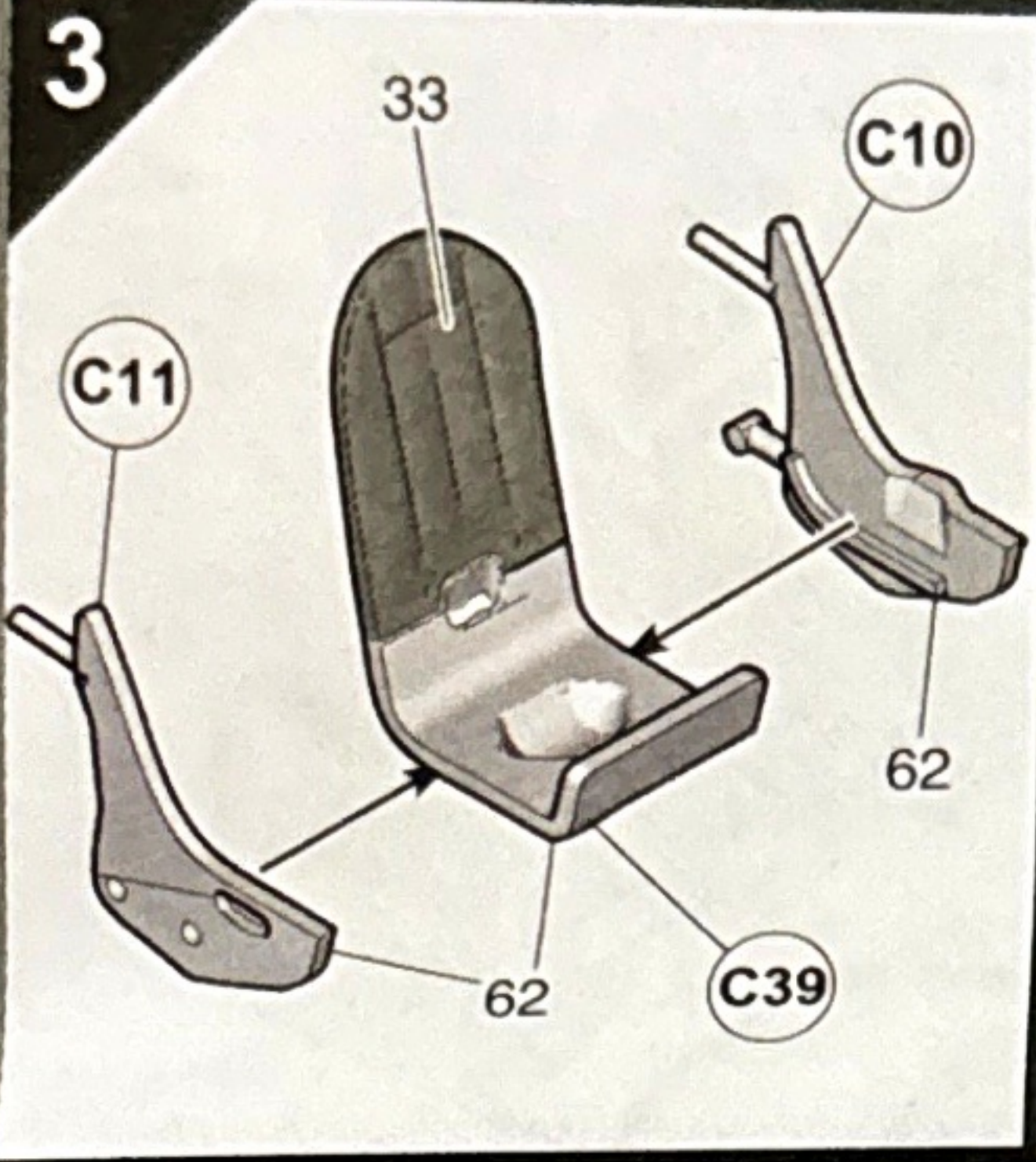
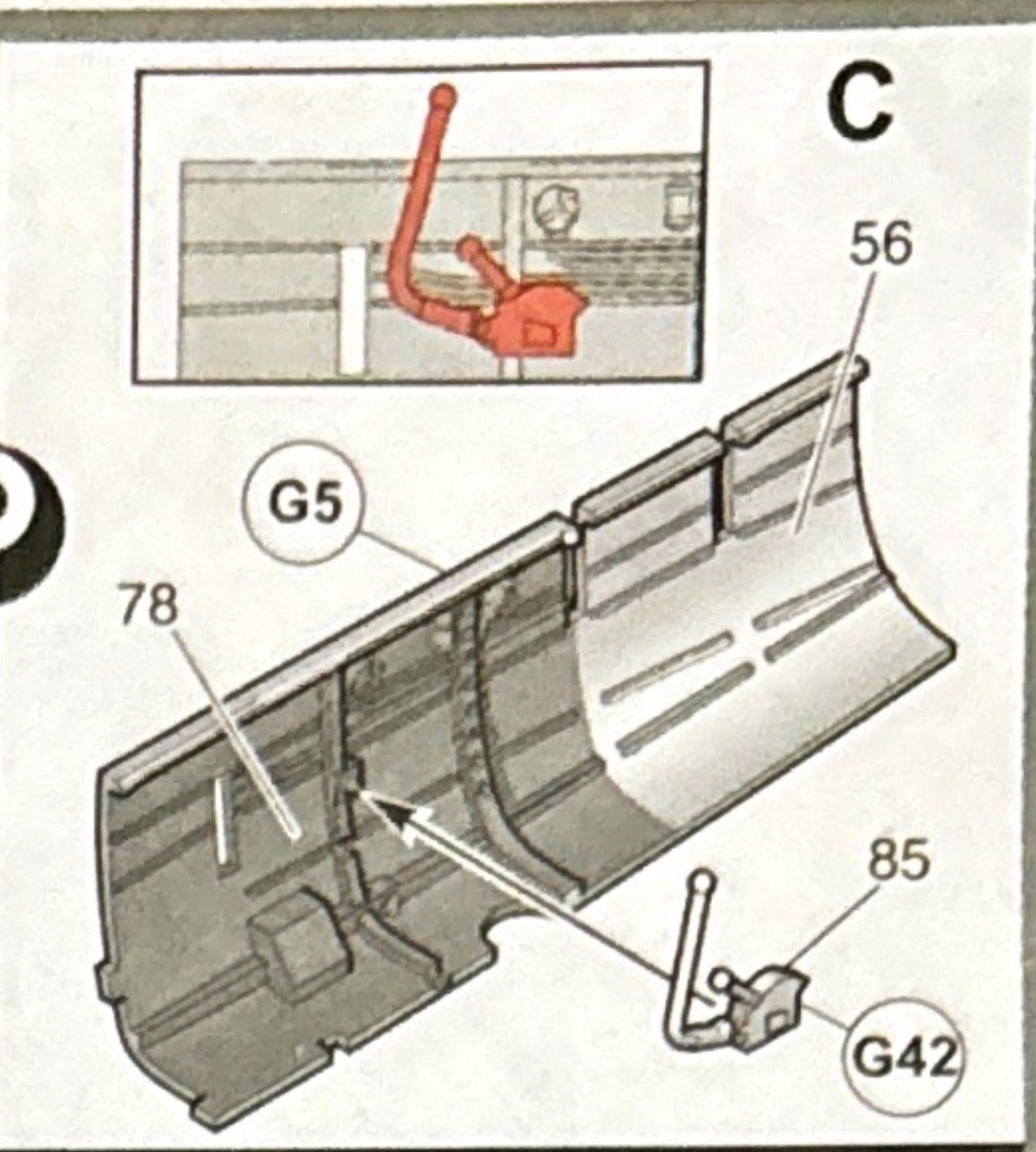
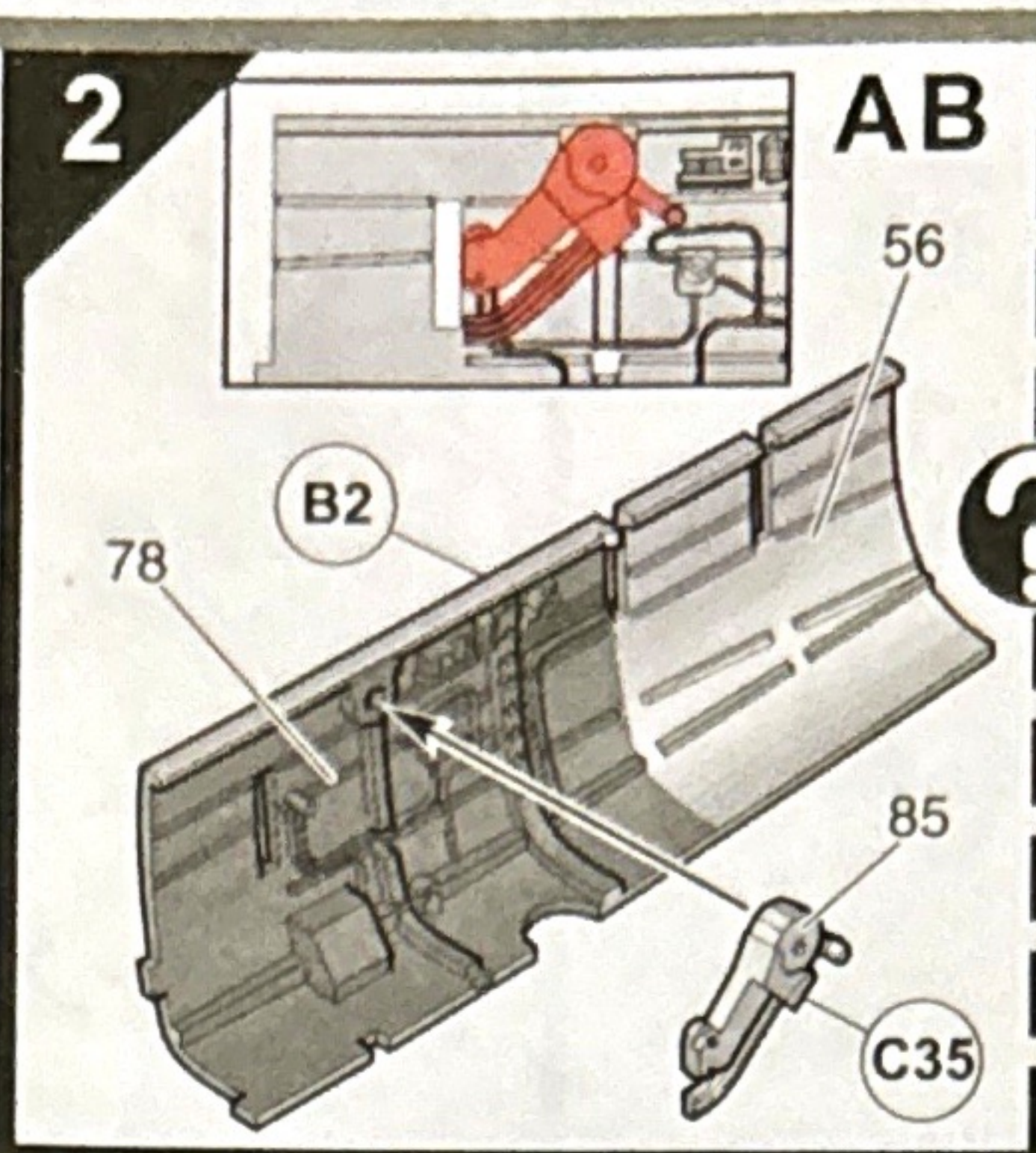
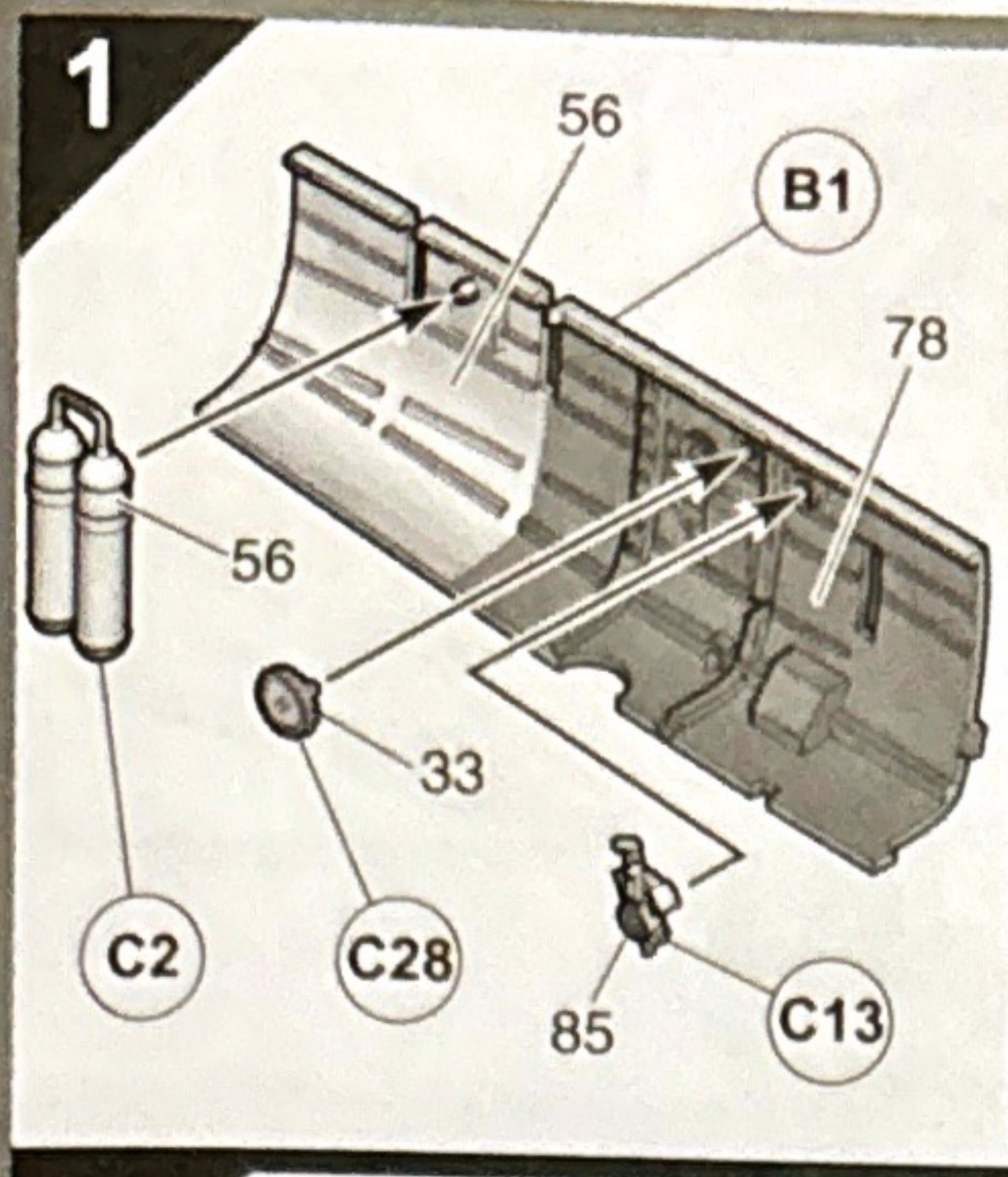

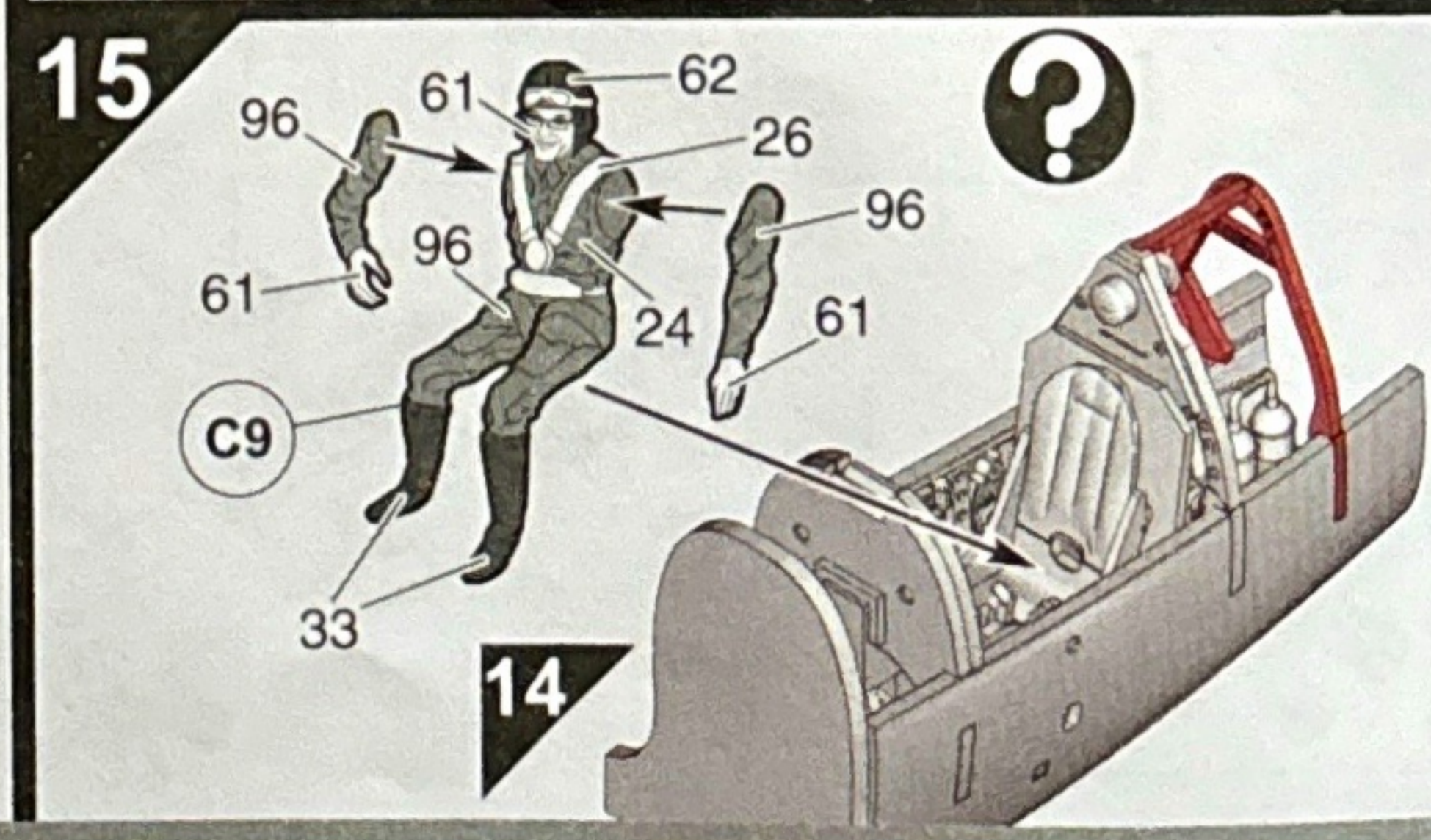
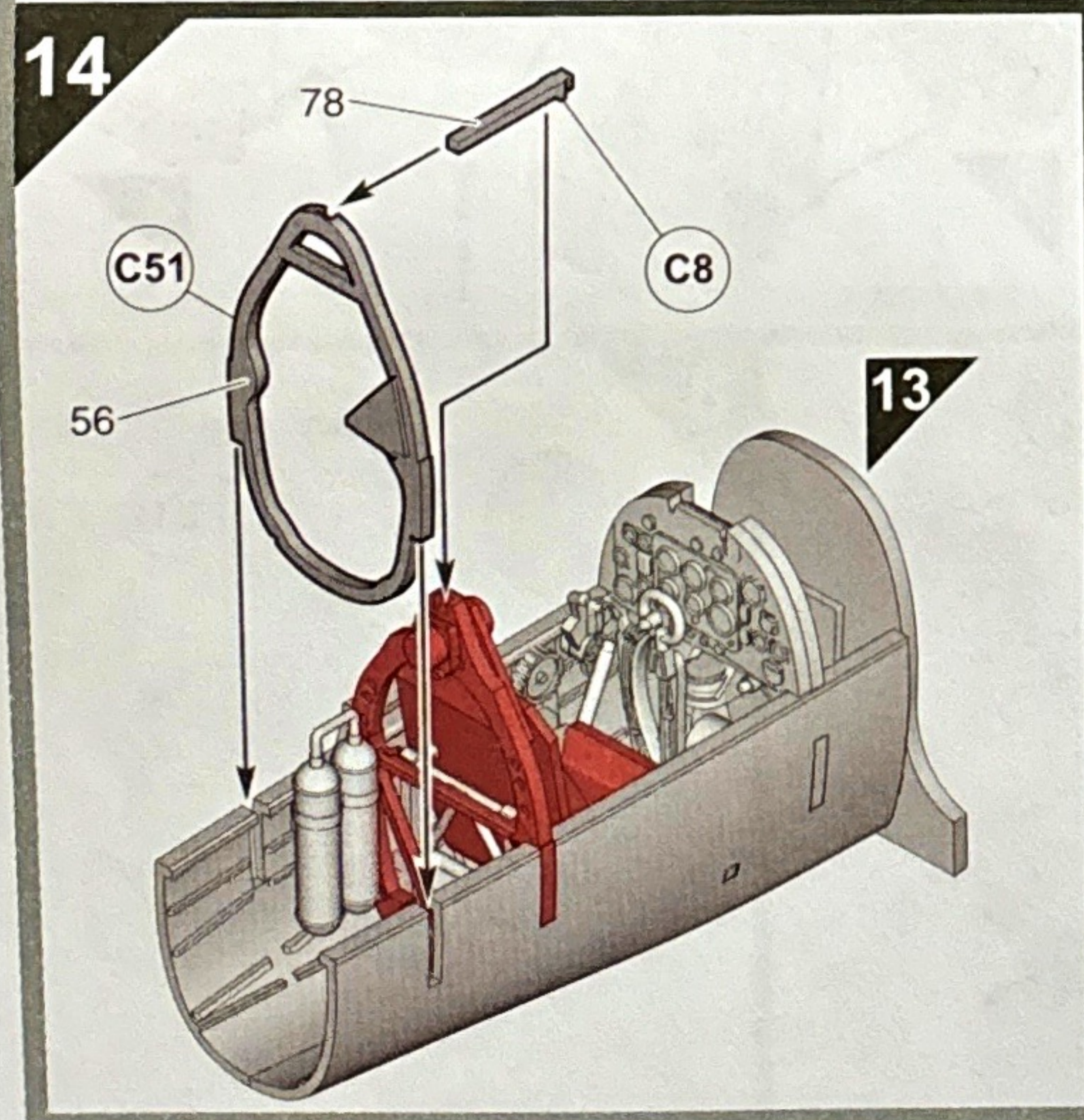
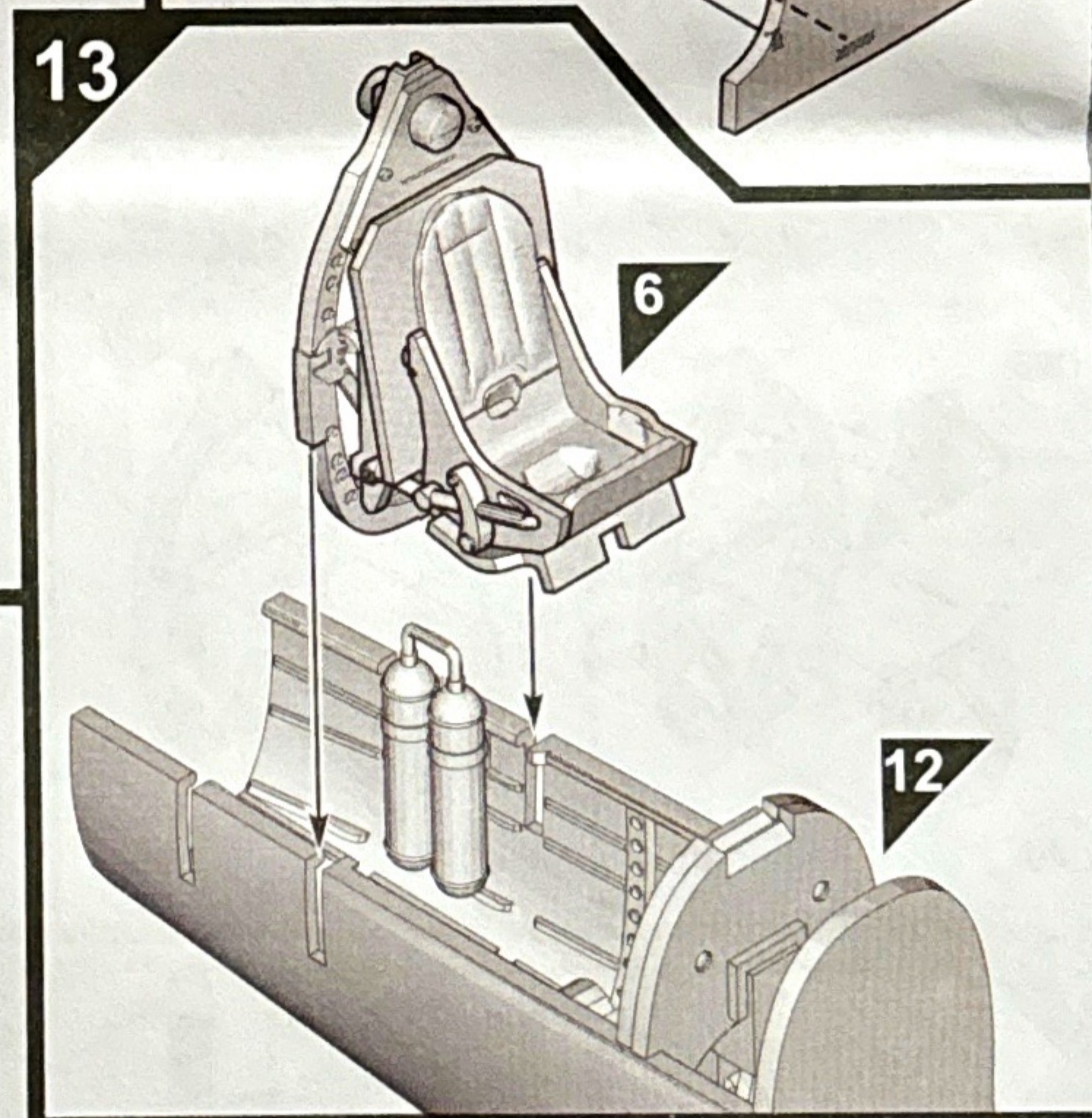
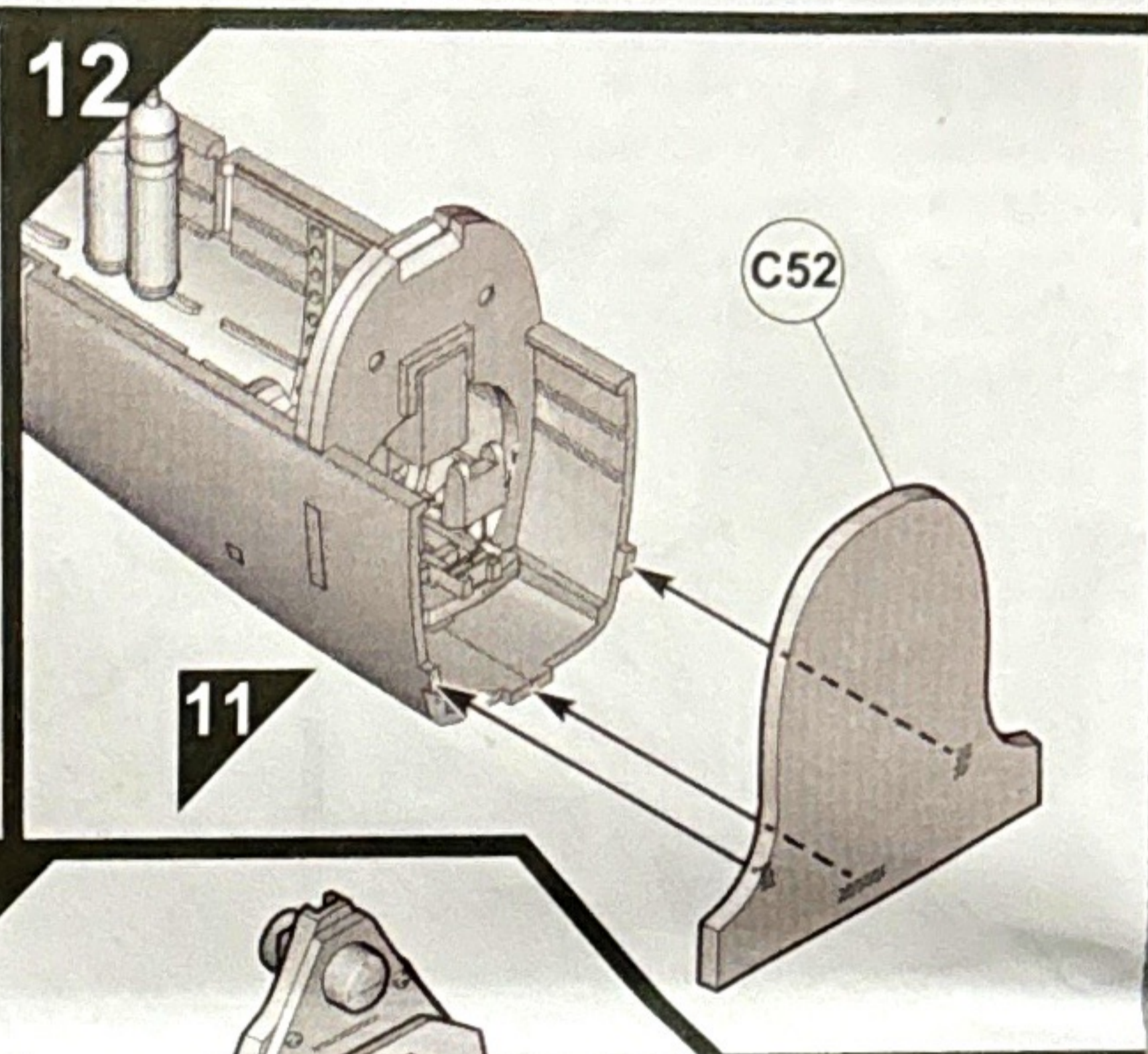
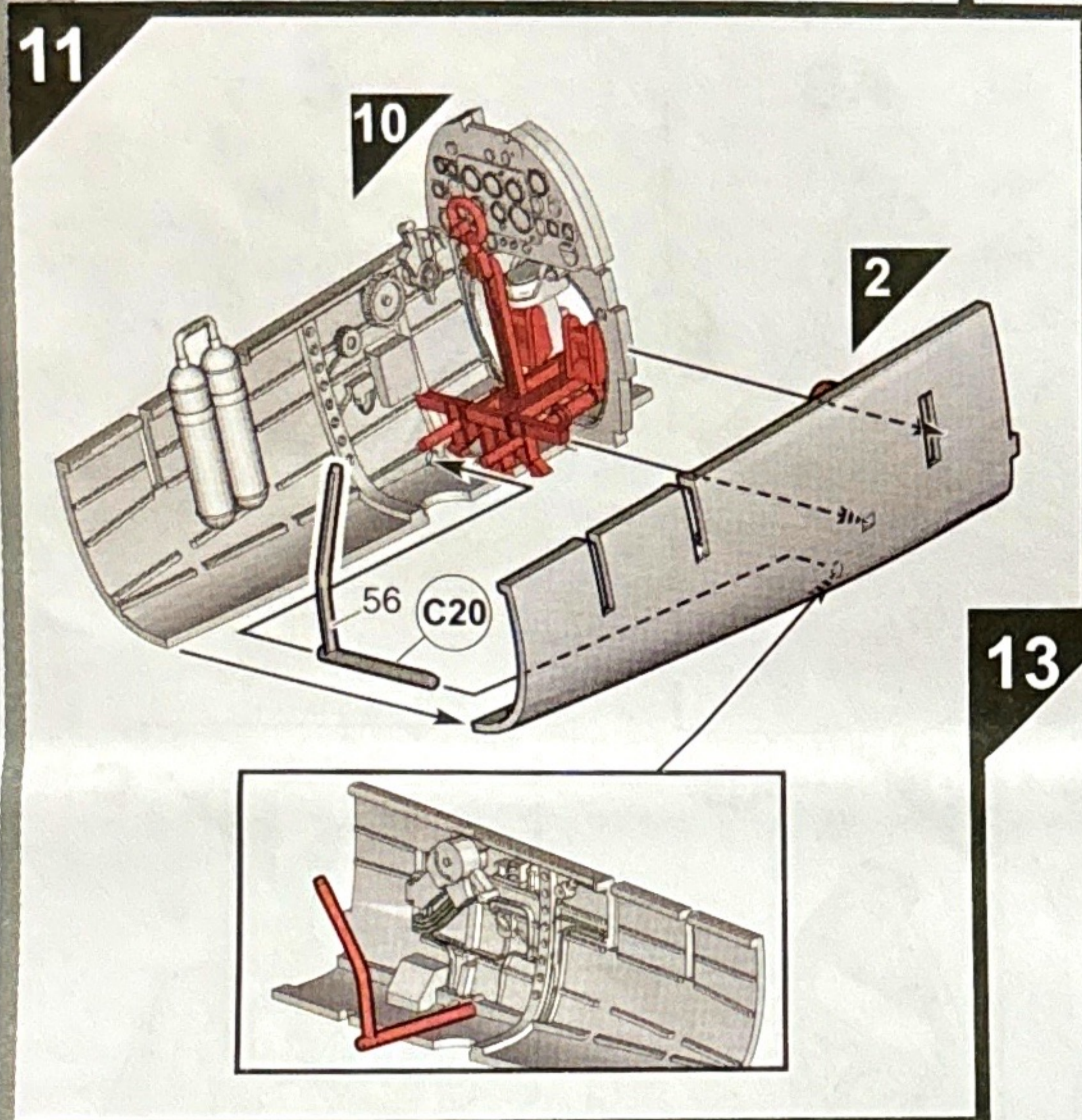
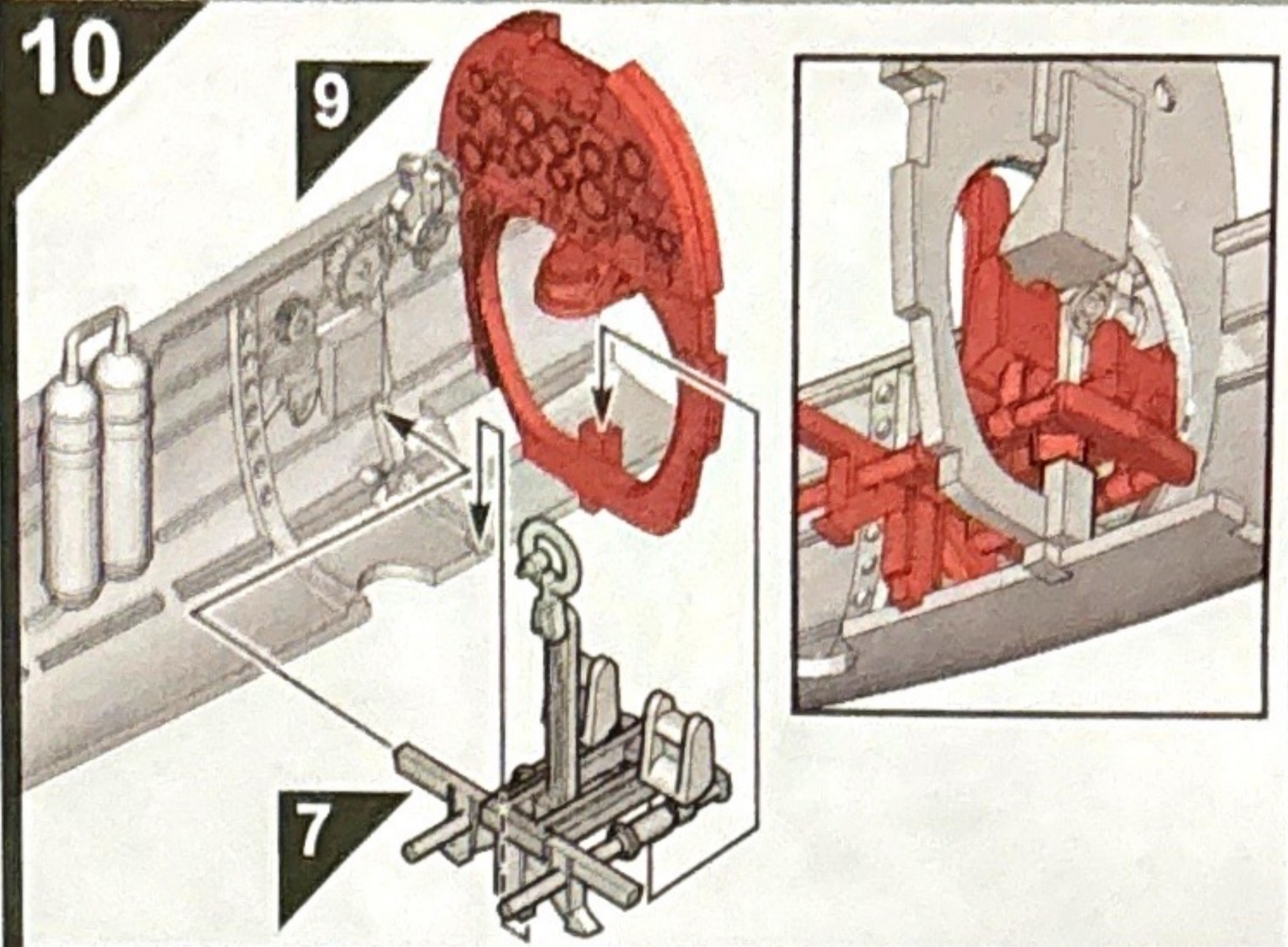
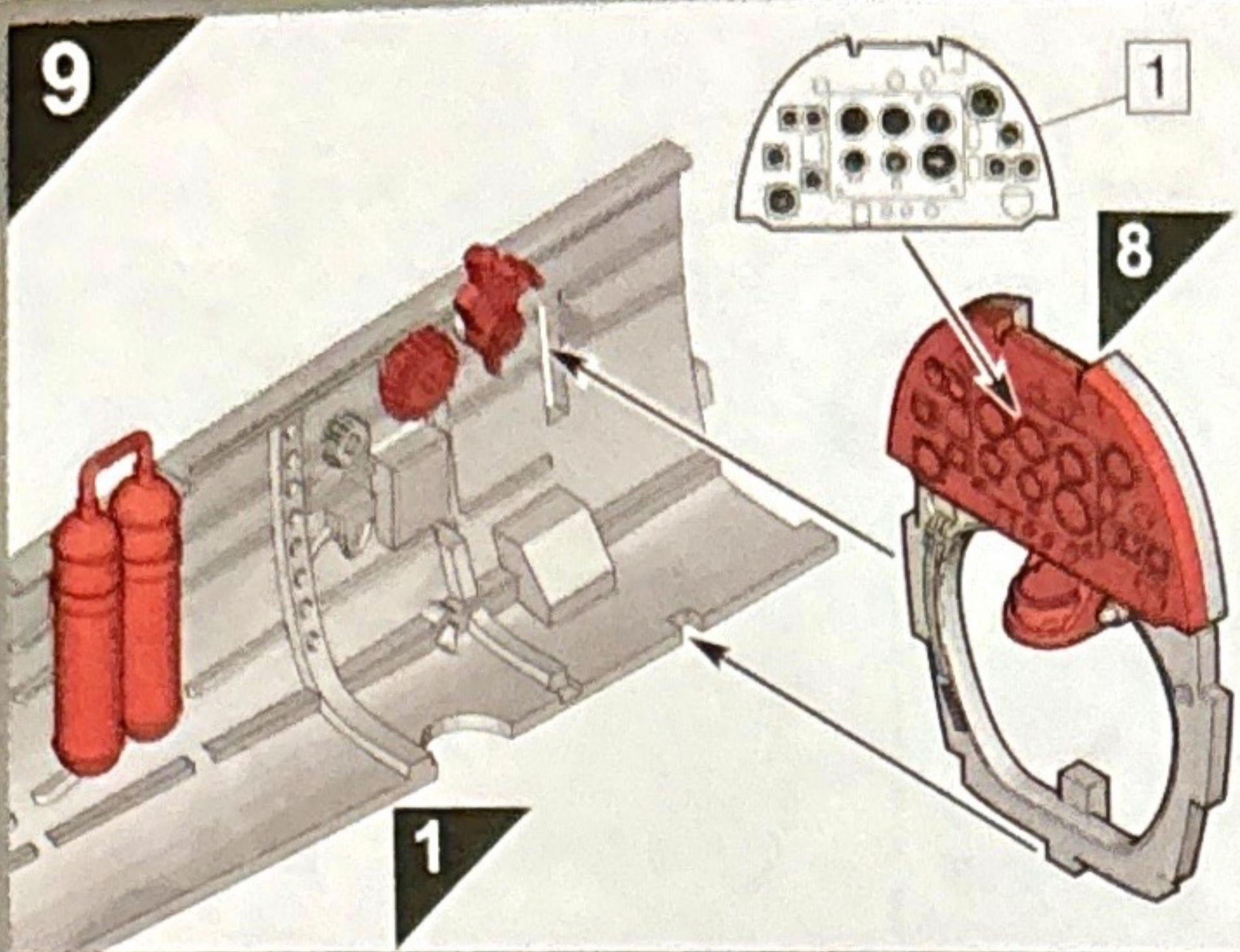

16

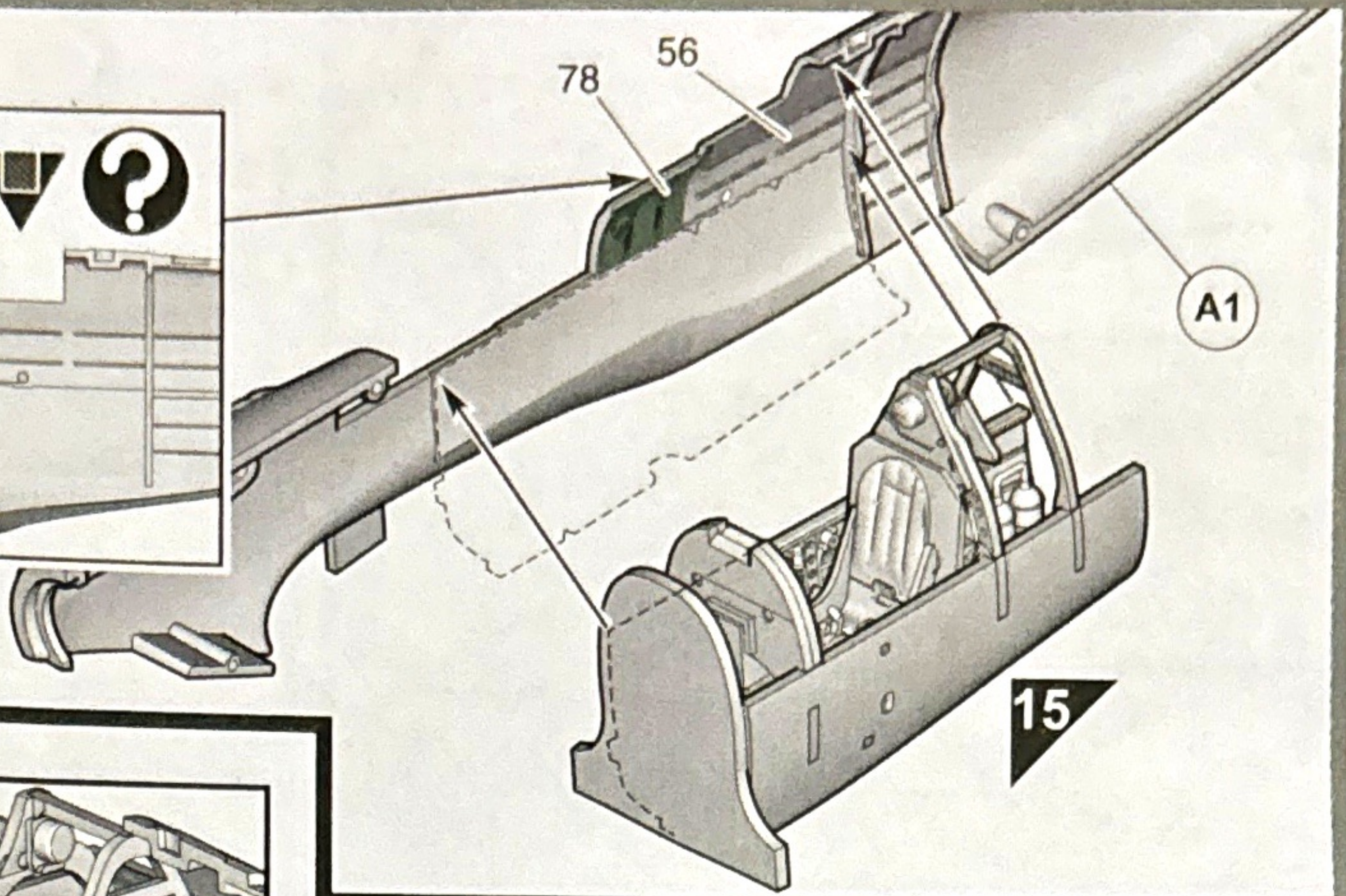
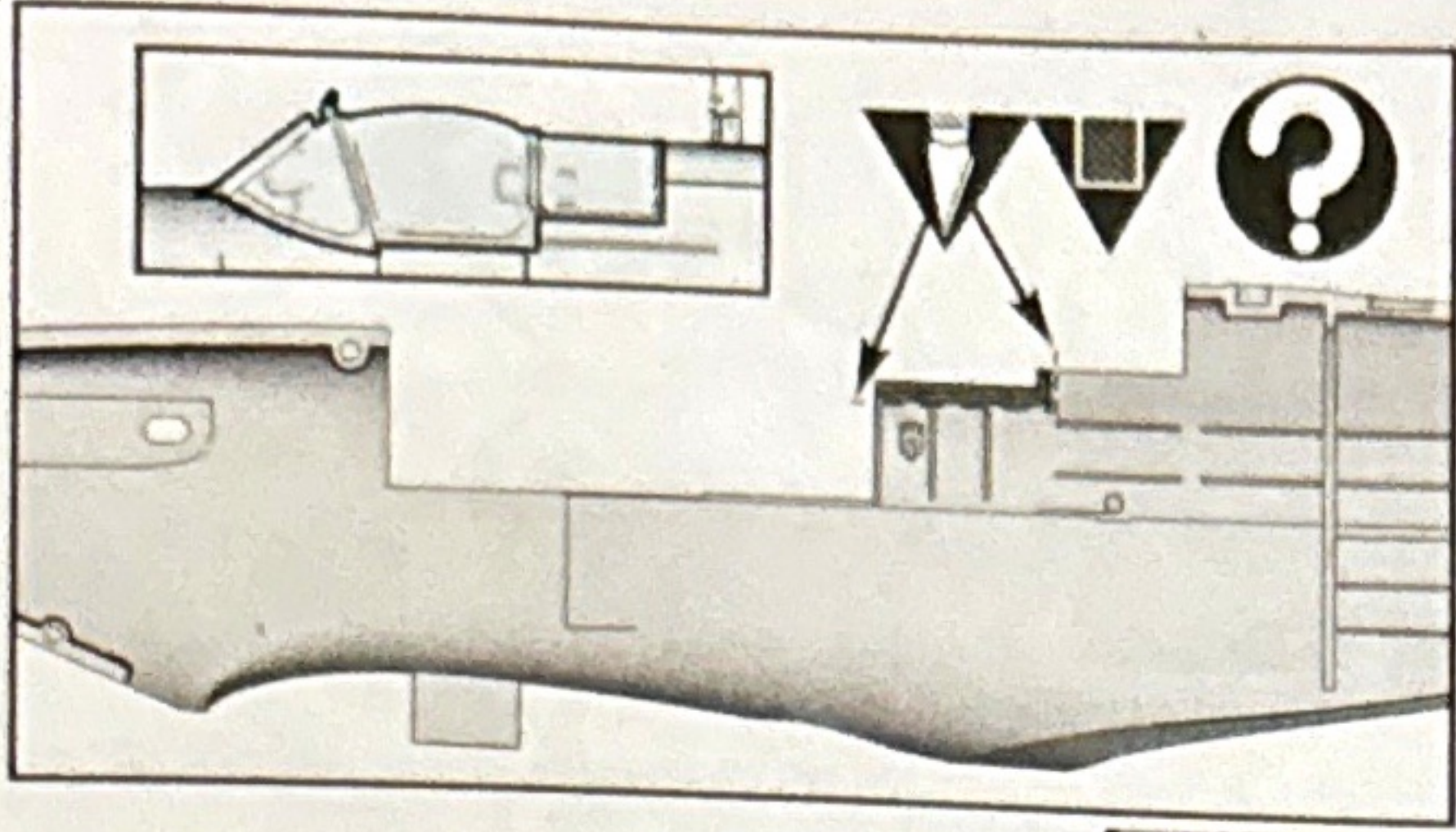

17

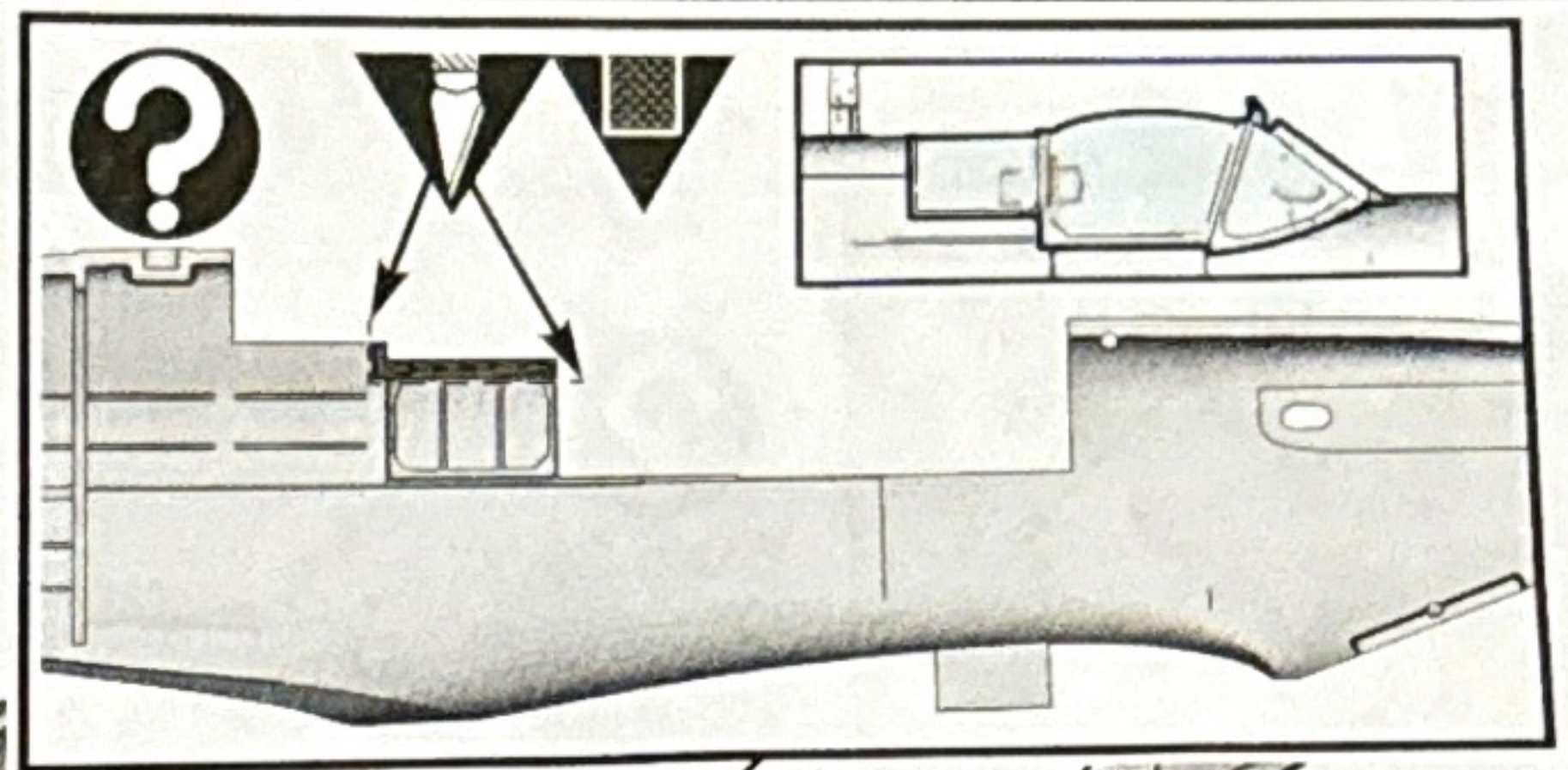
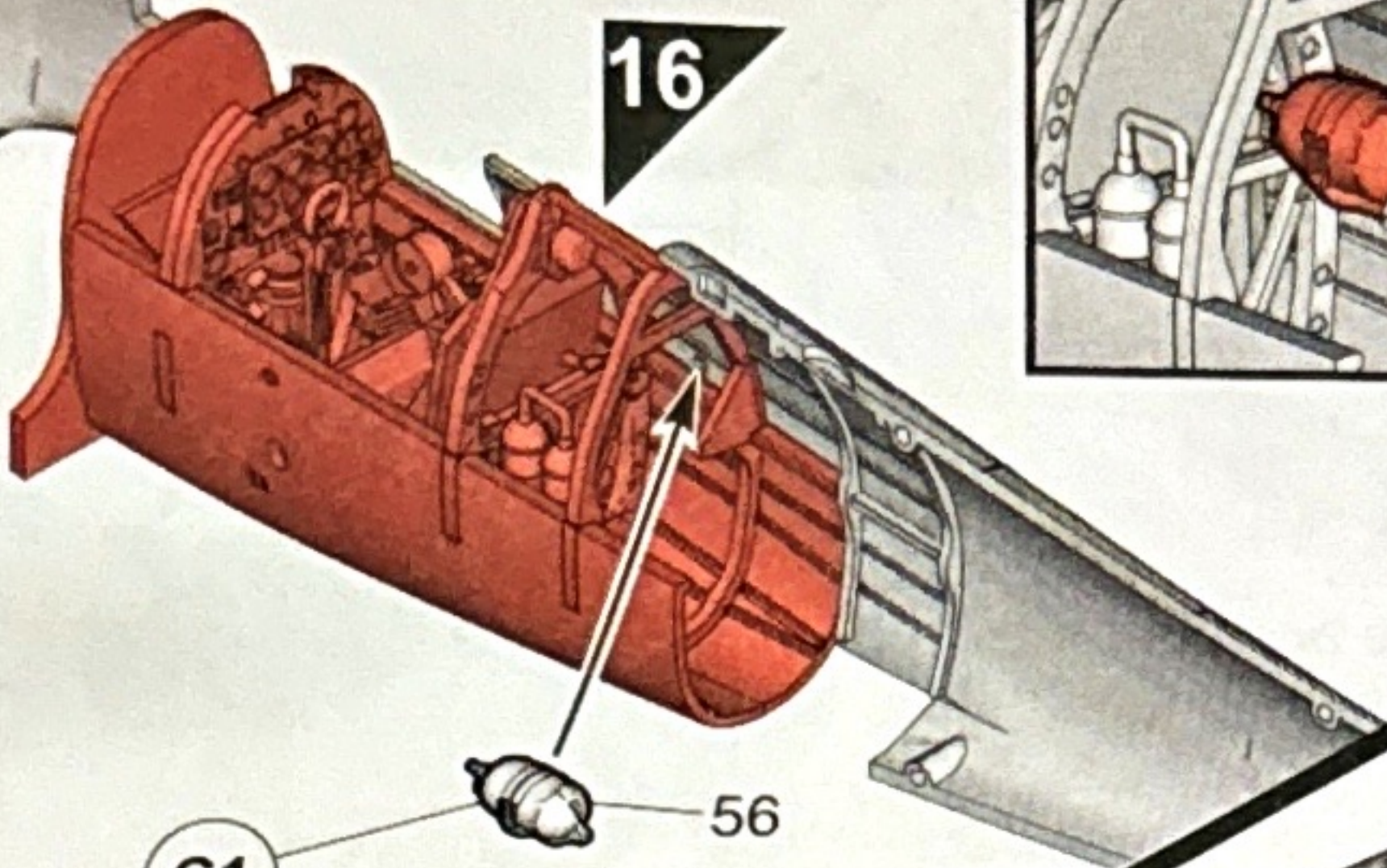
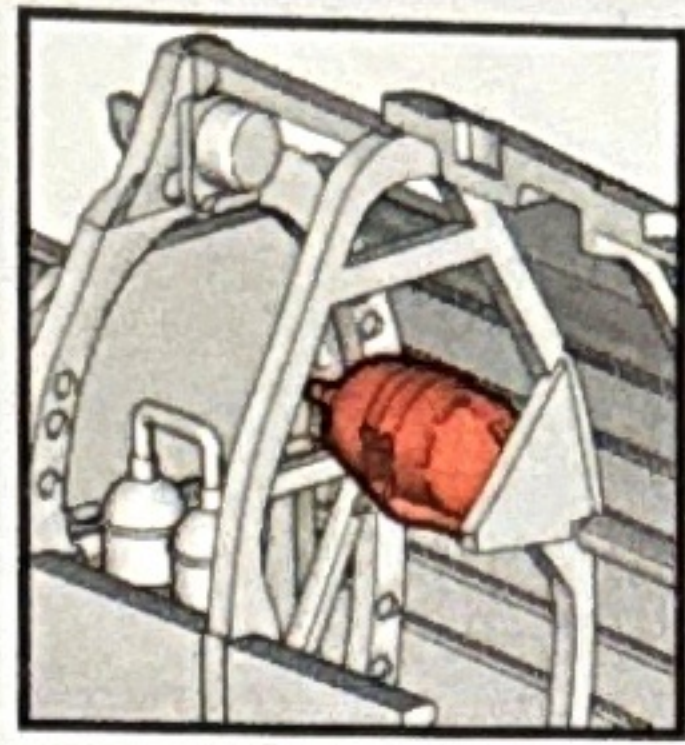

18

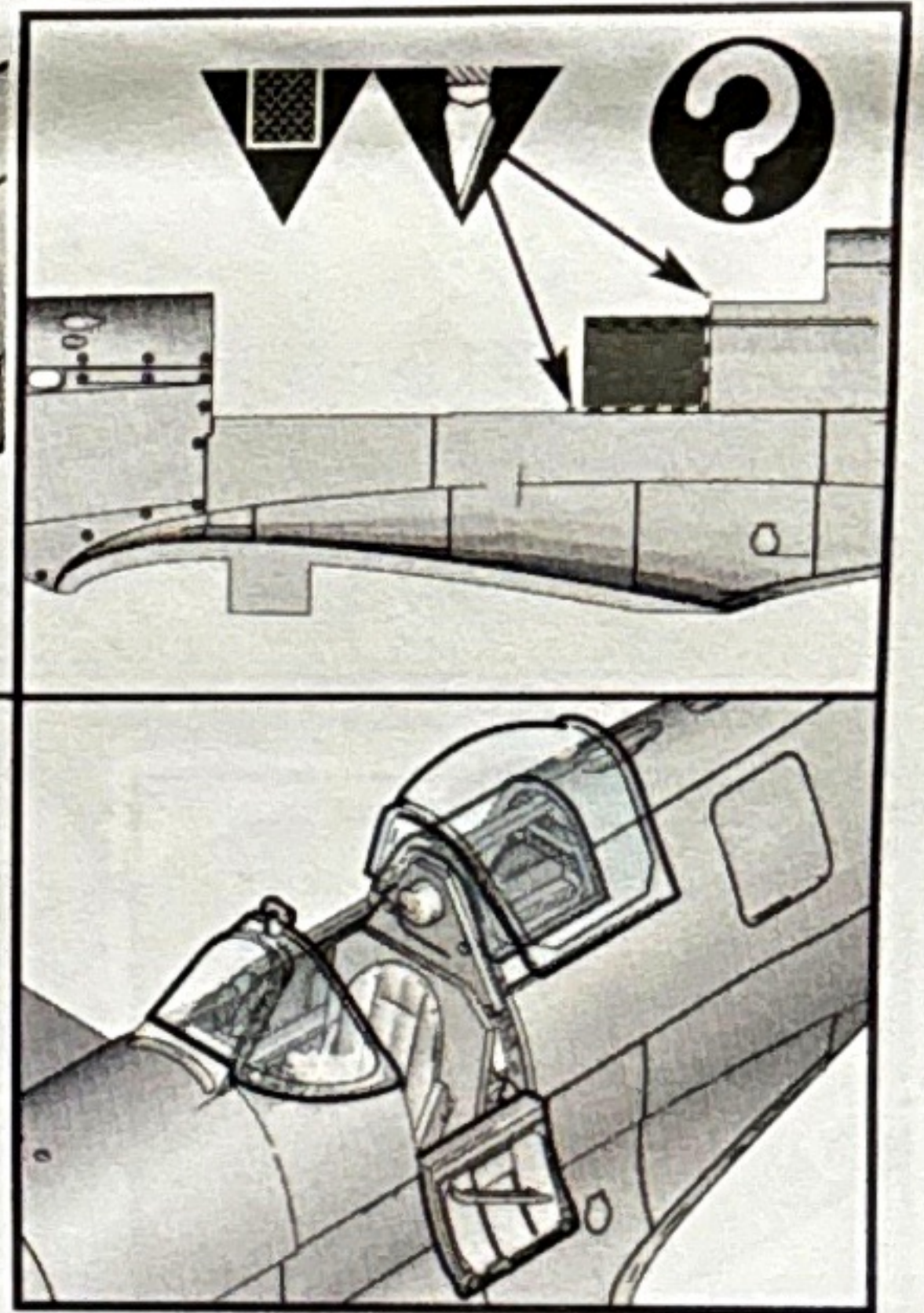
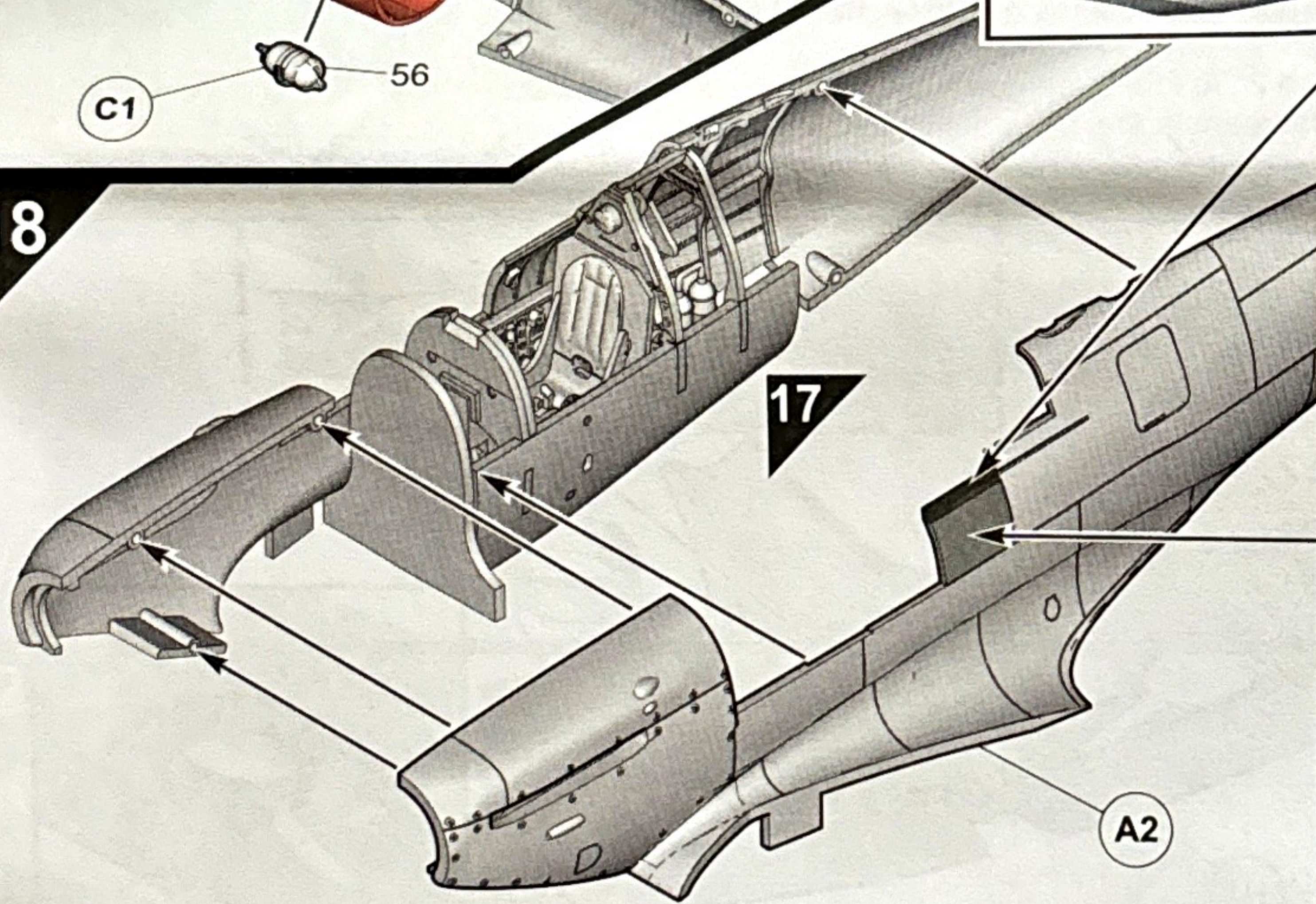

19

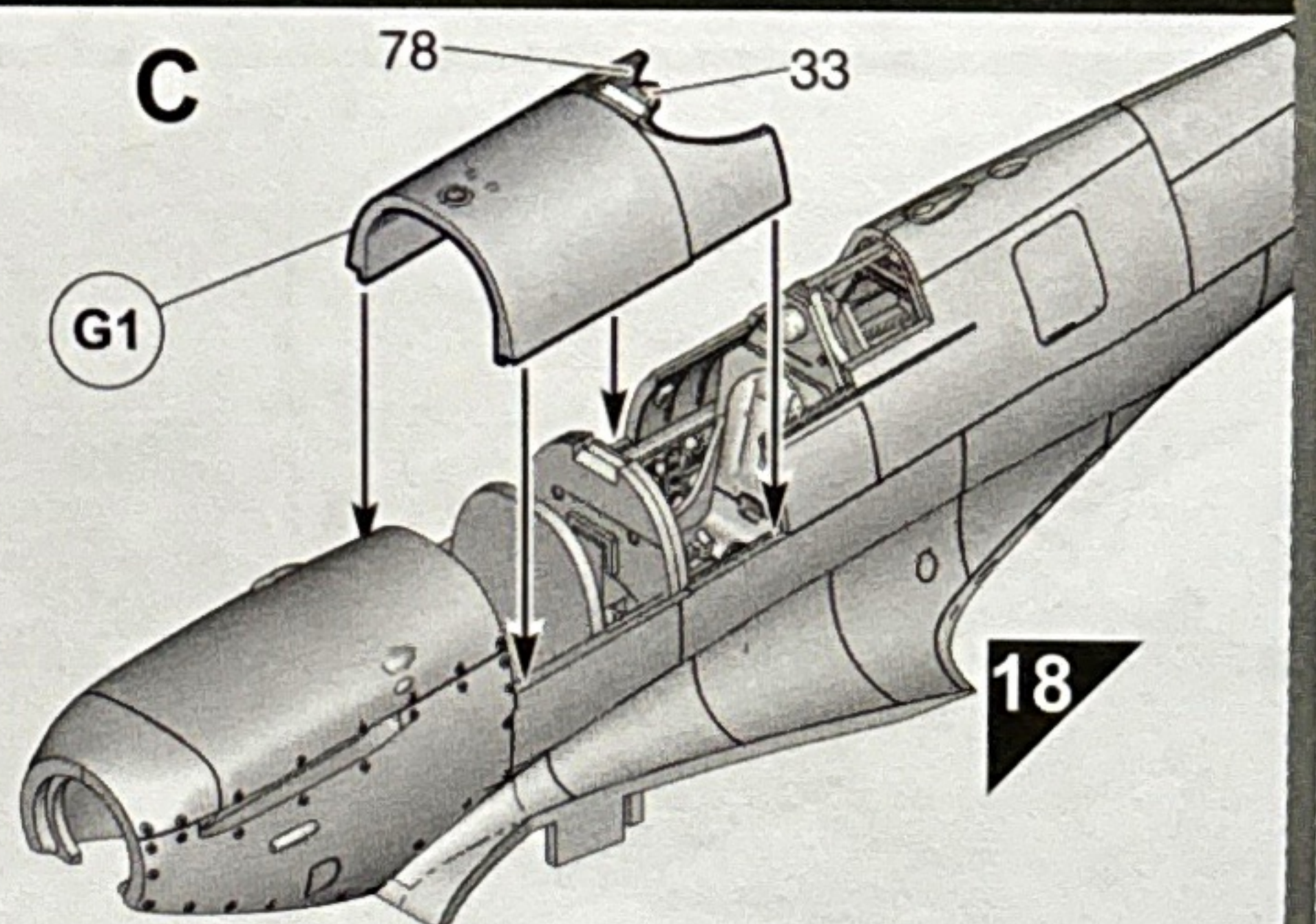
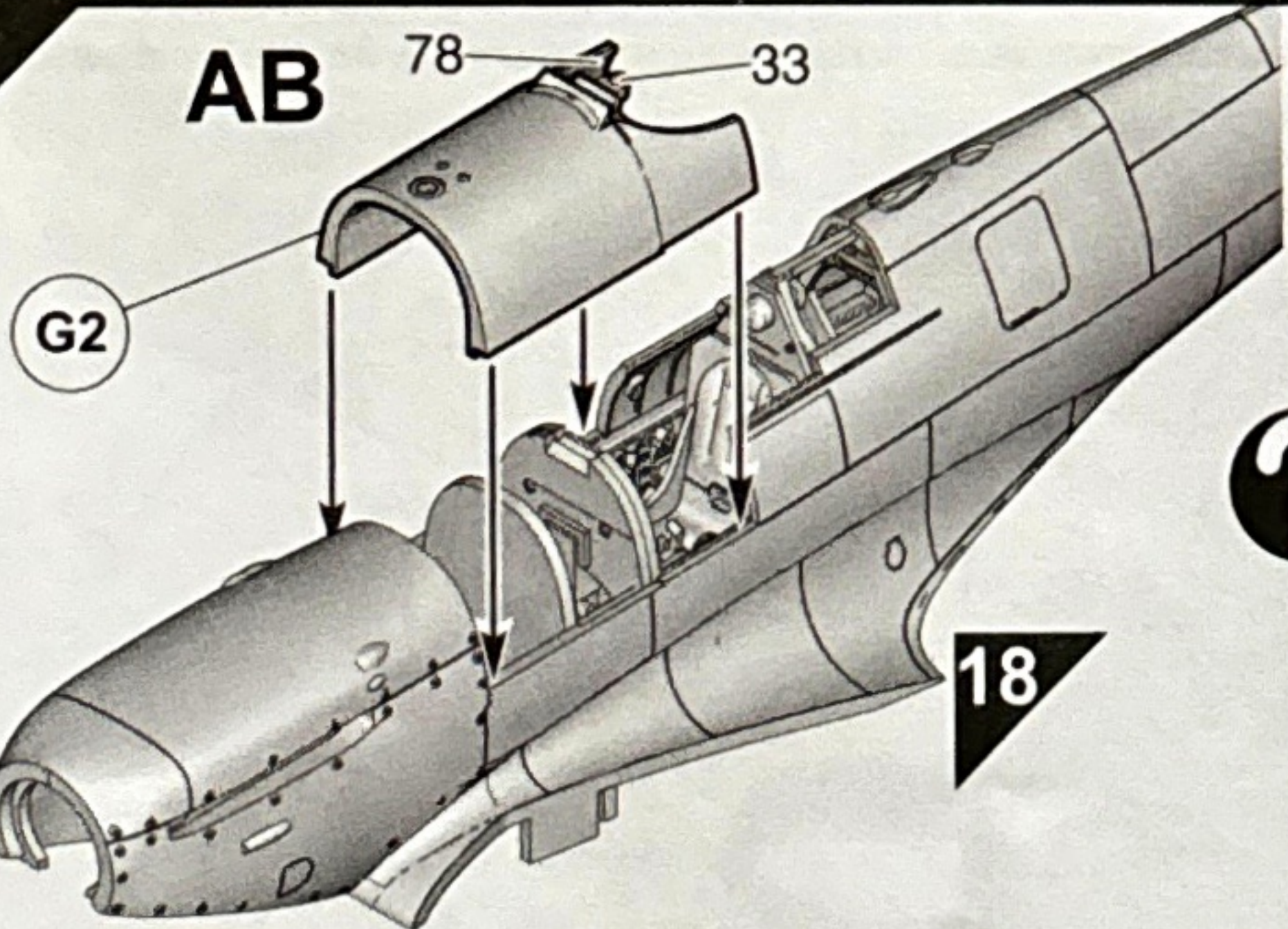

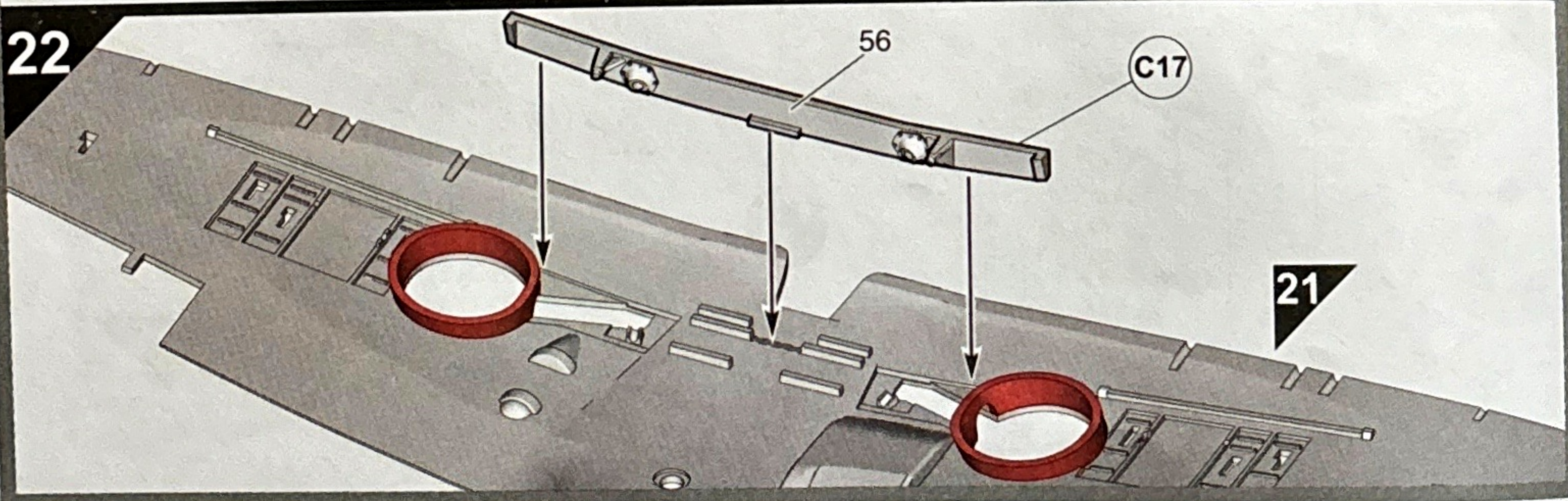
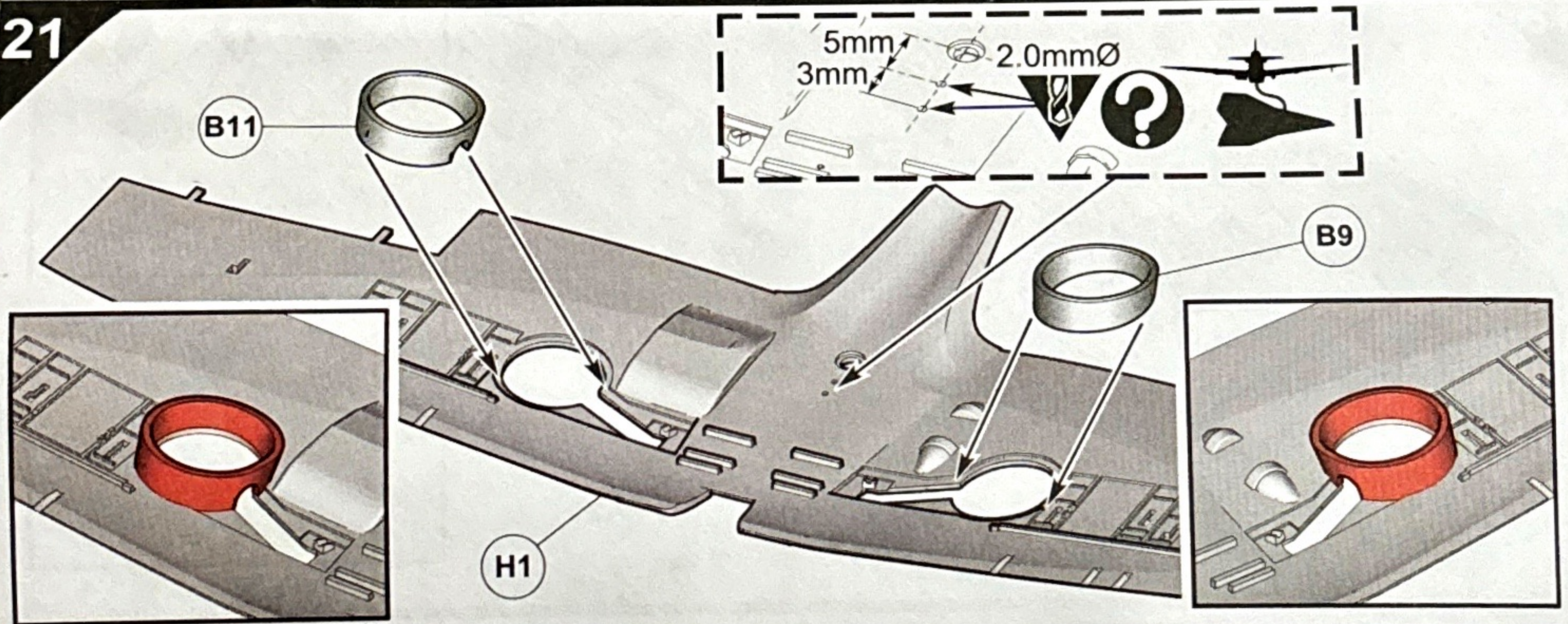
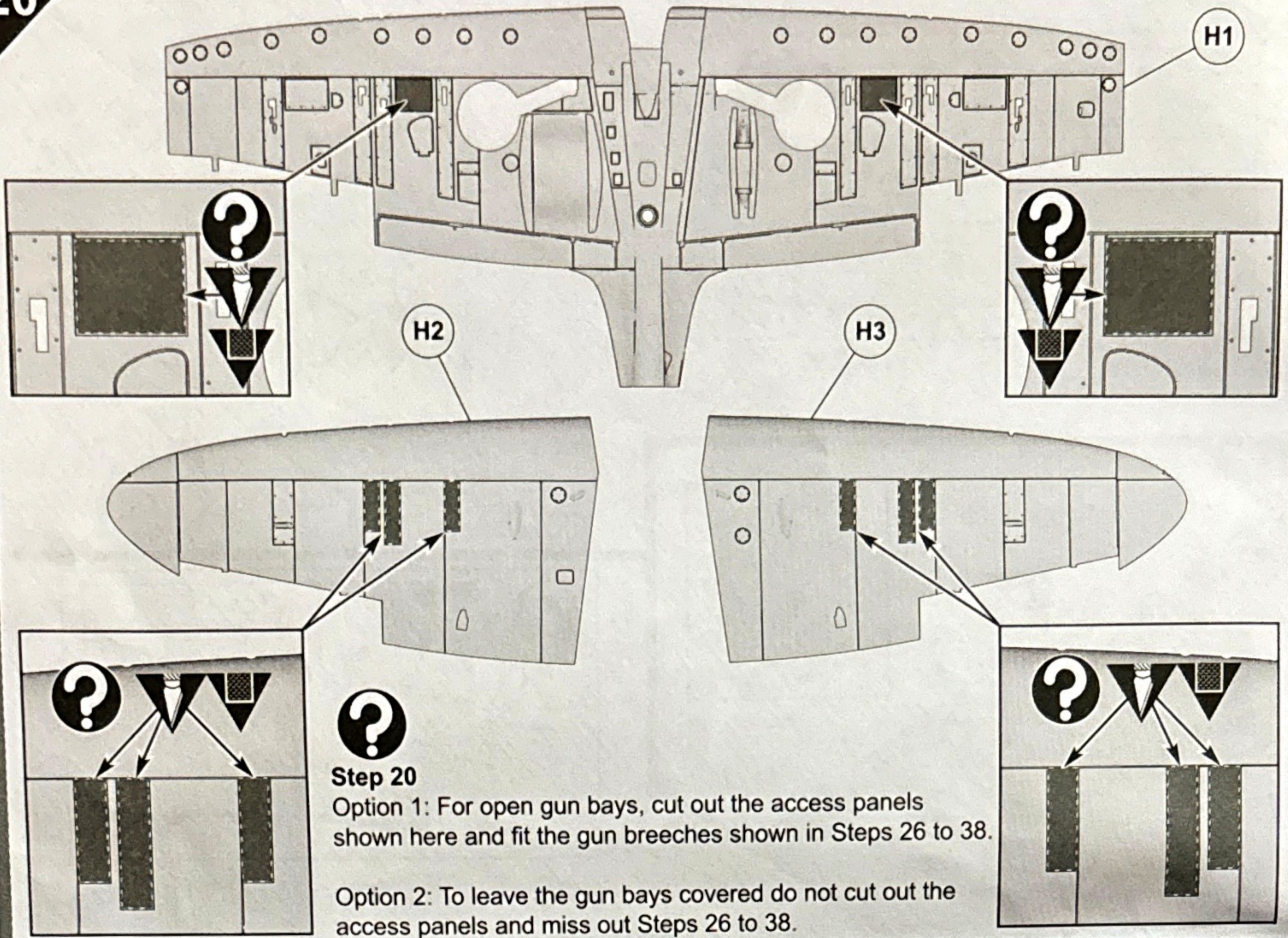

23

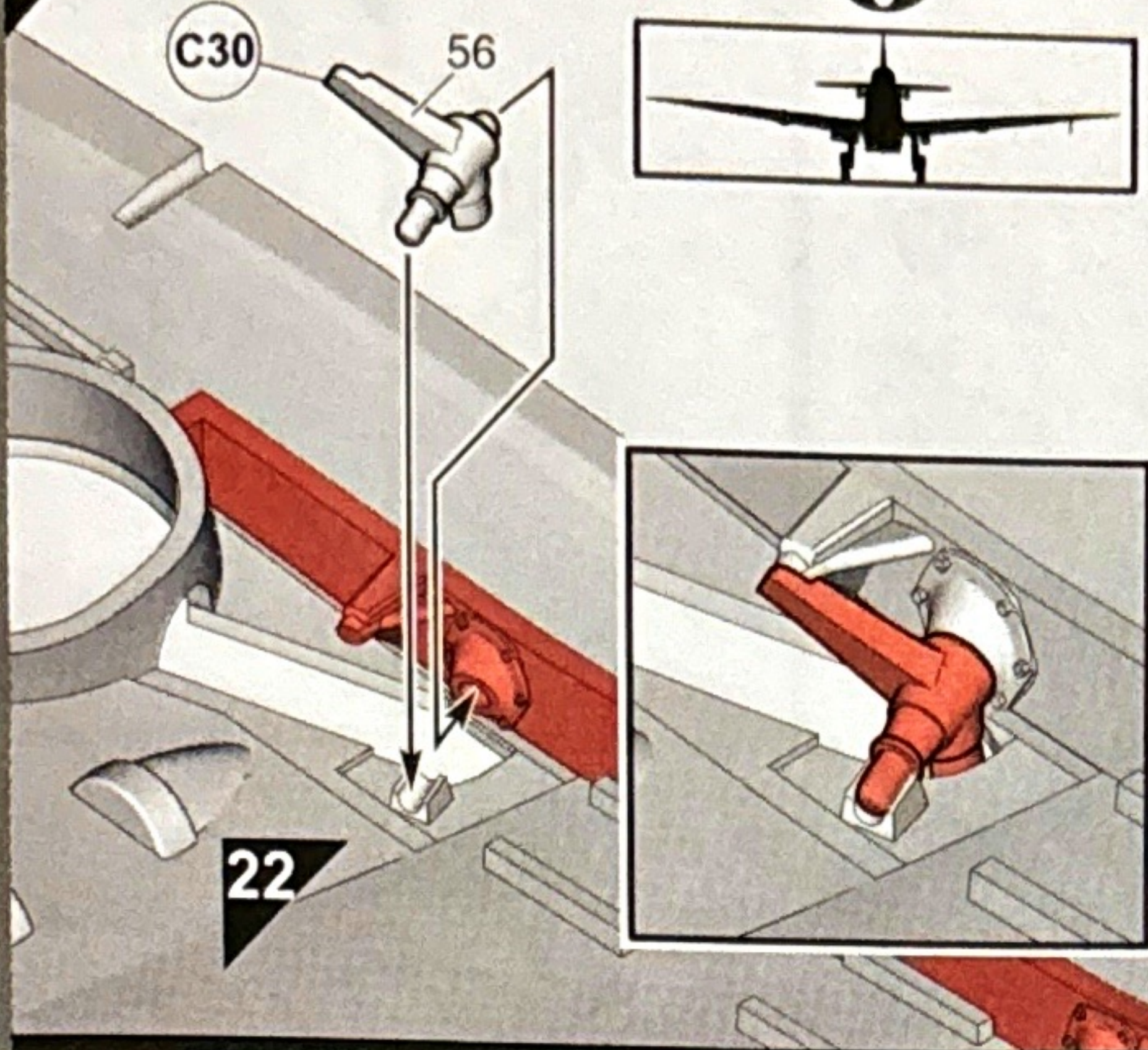

24

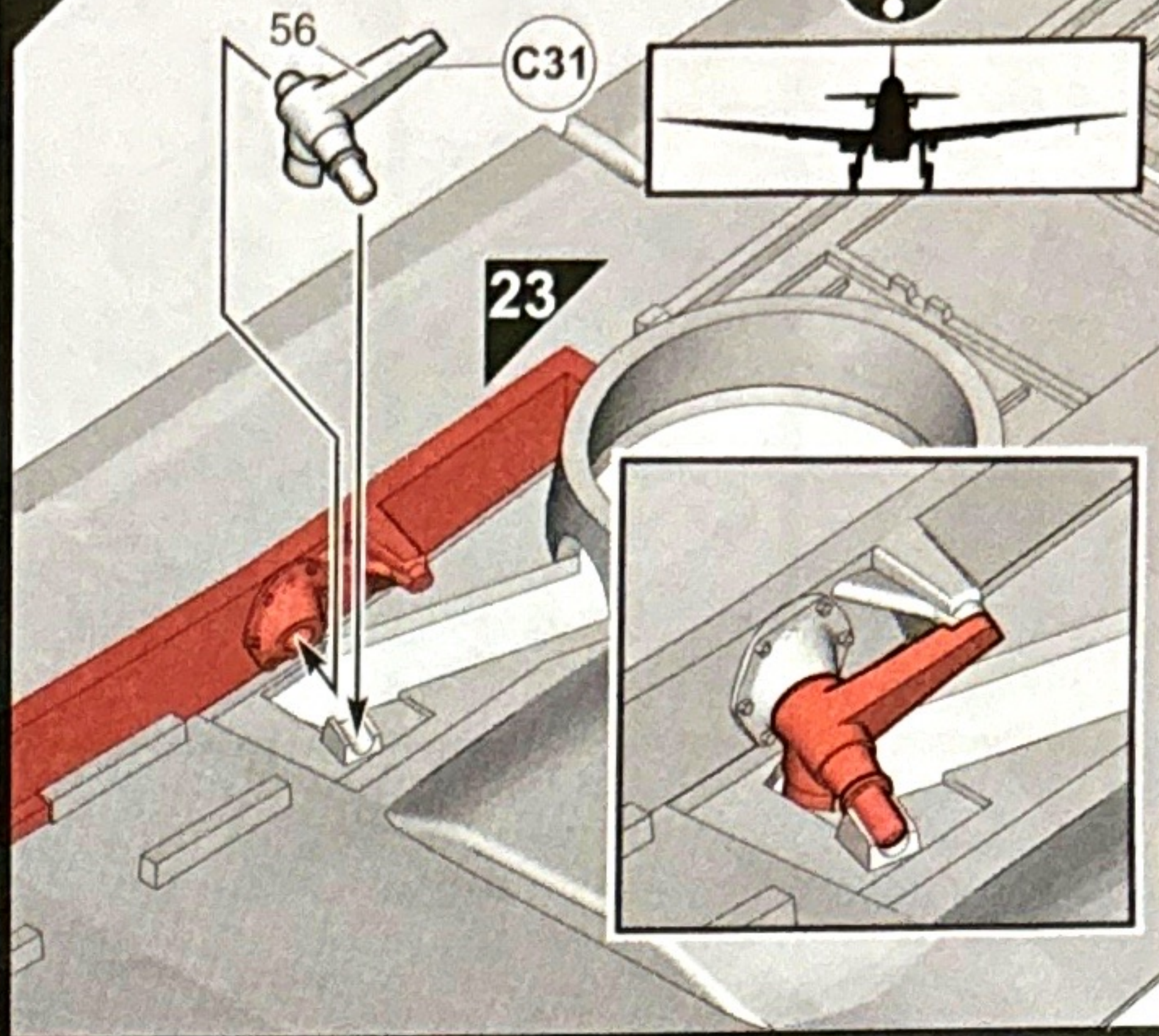

25

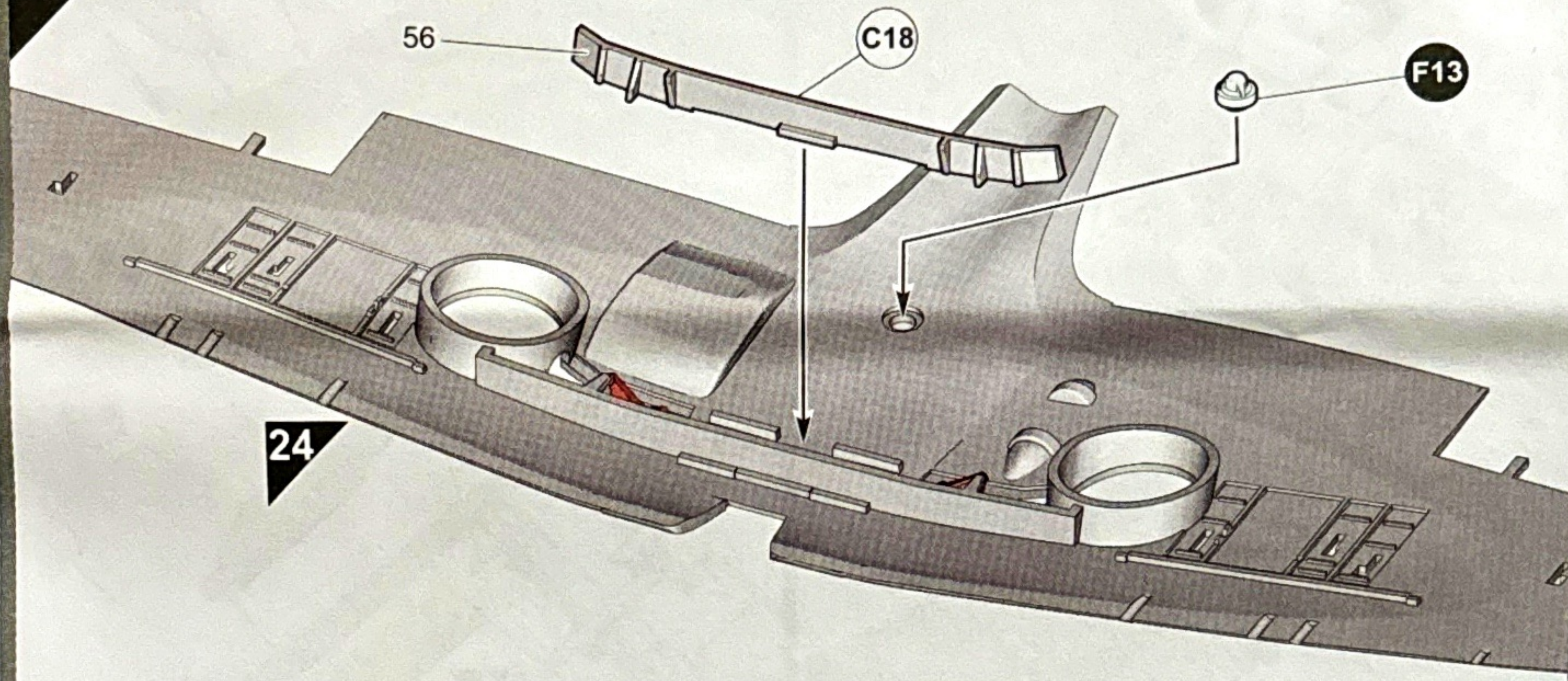

26

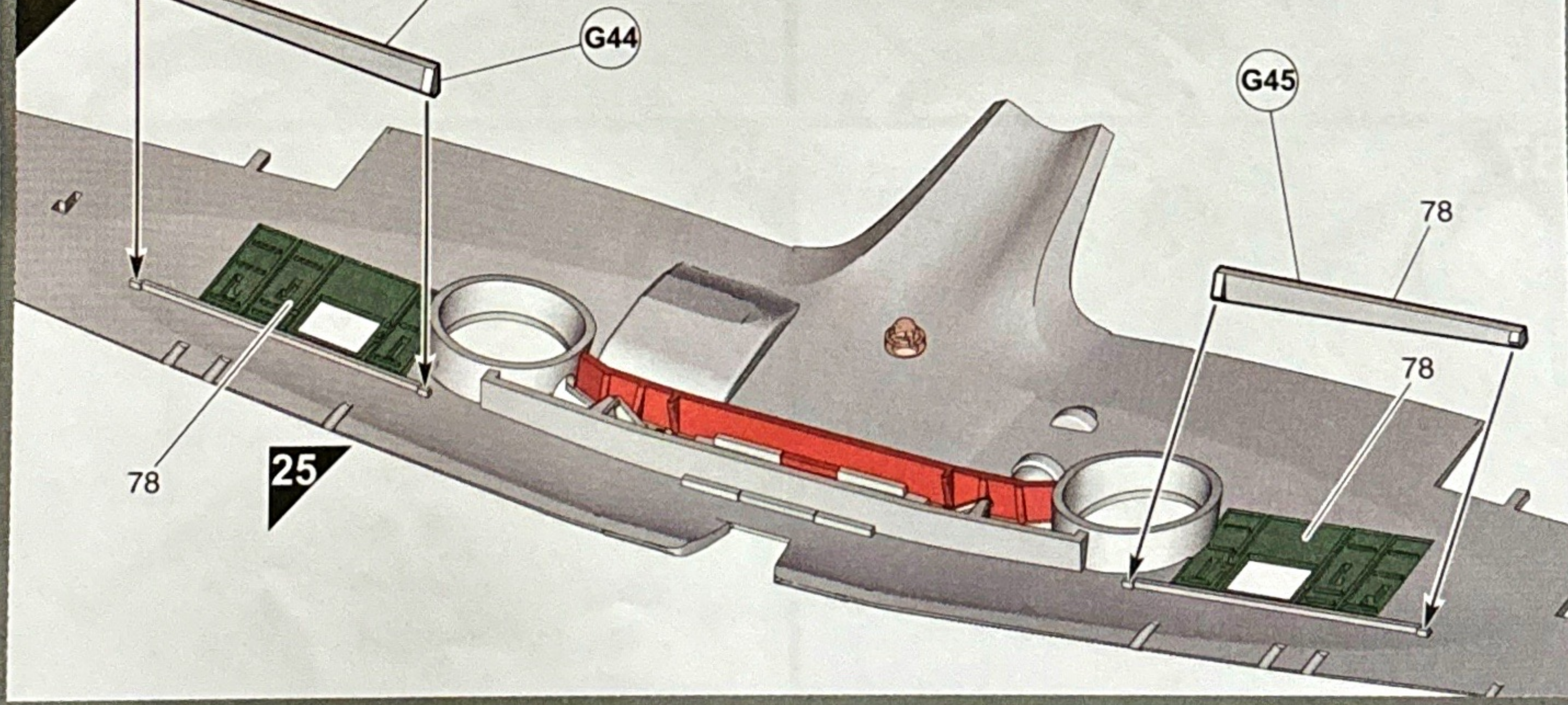

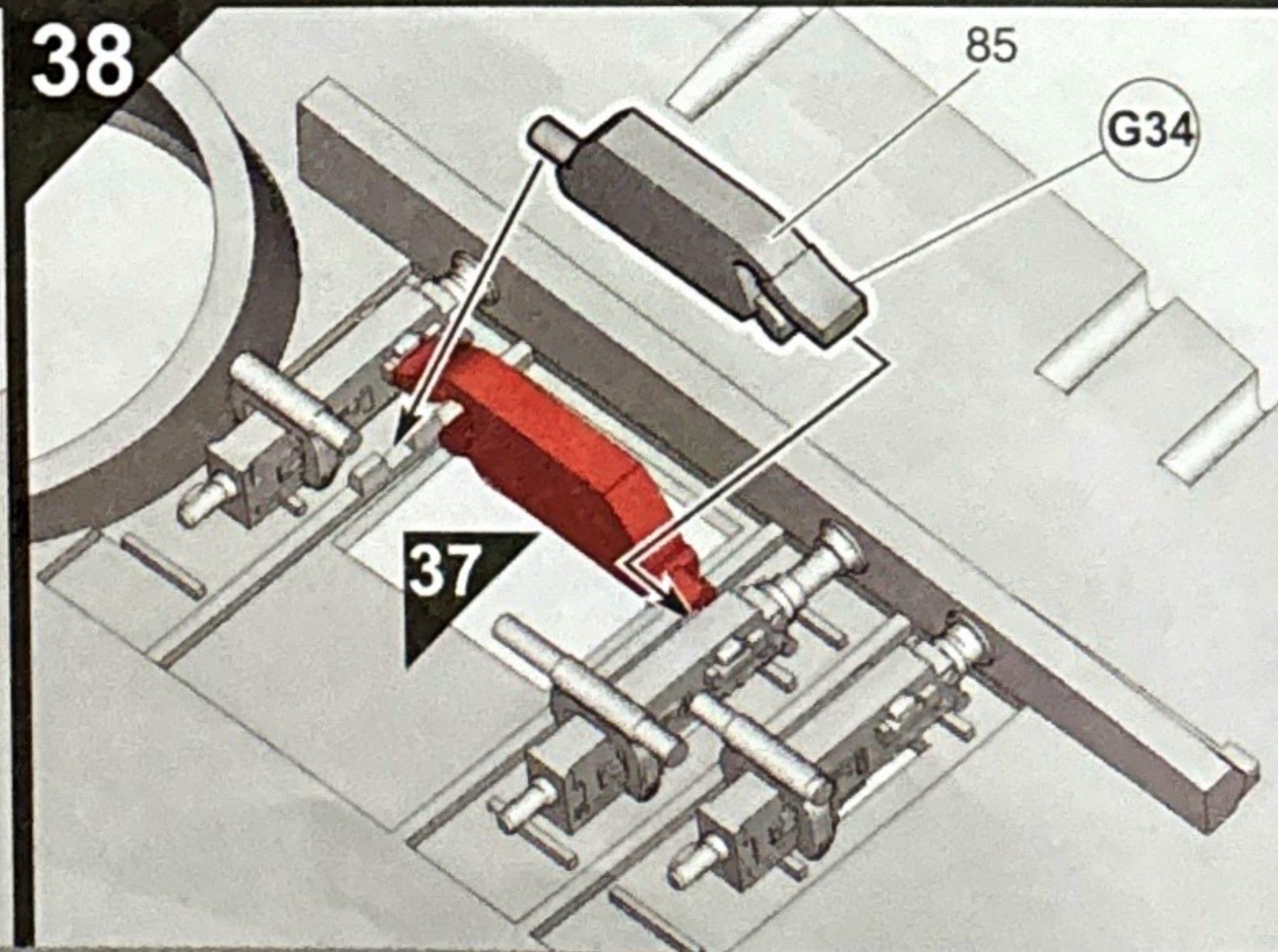
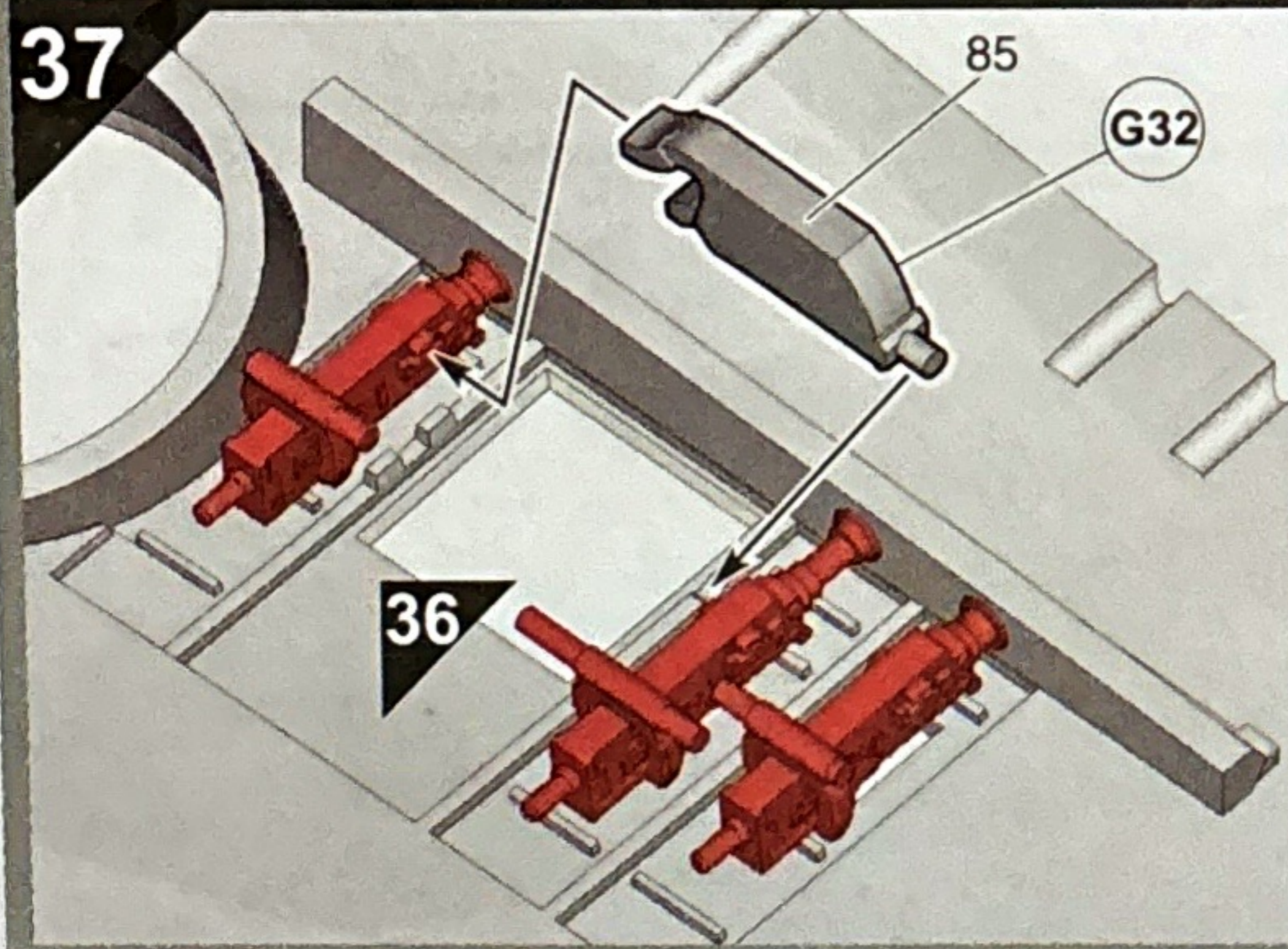
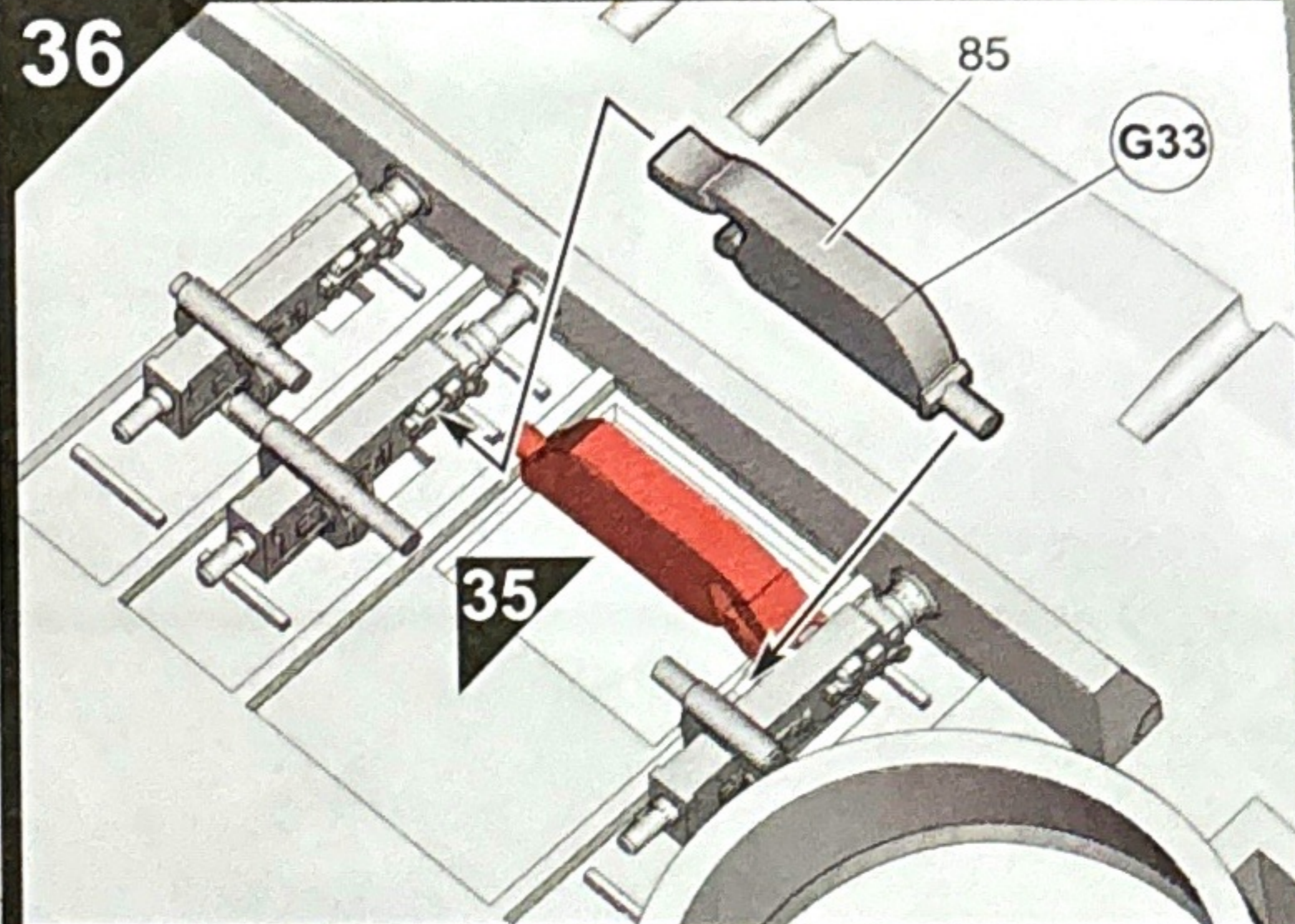
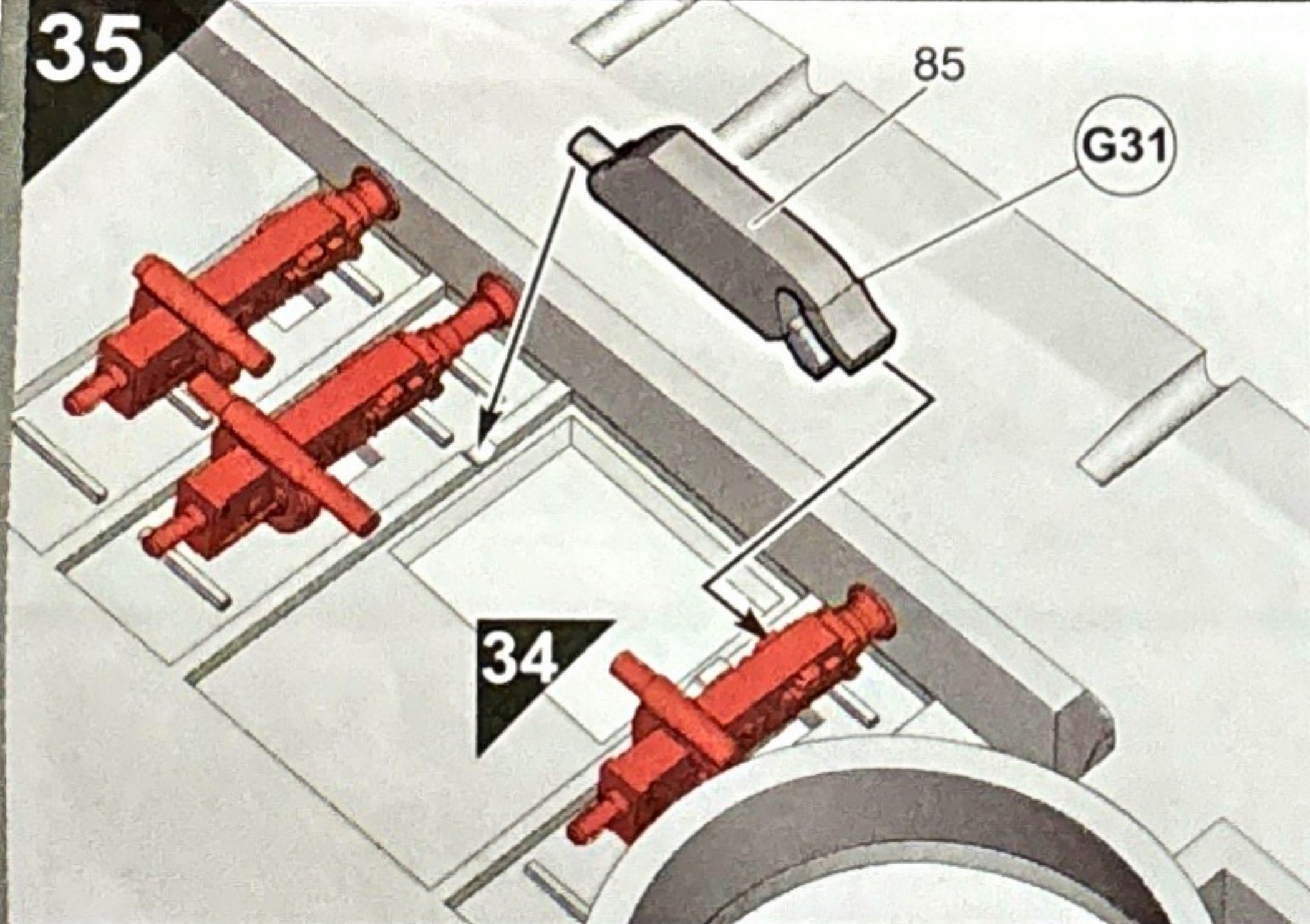
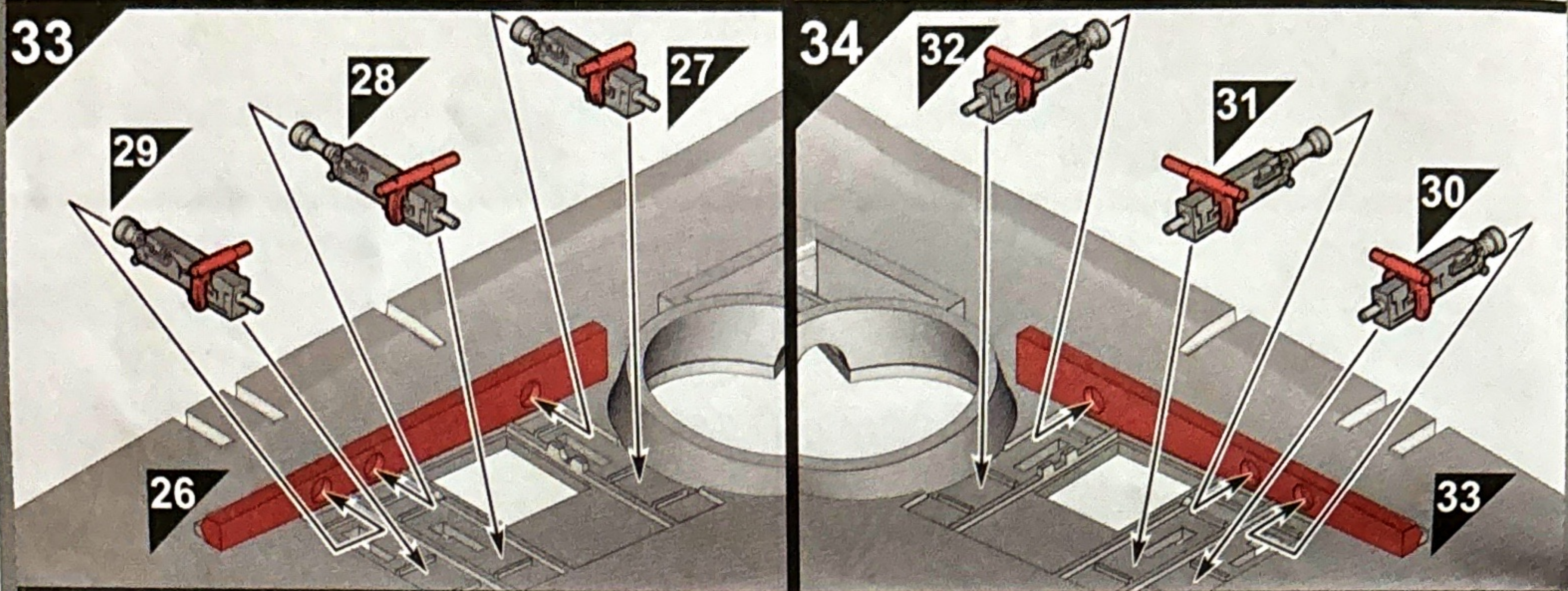
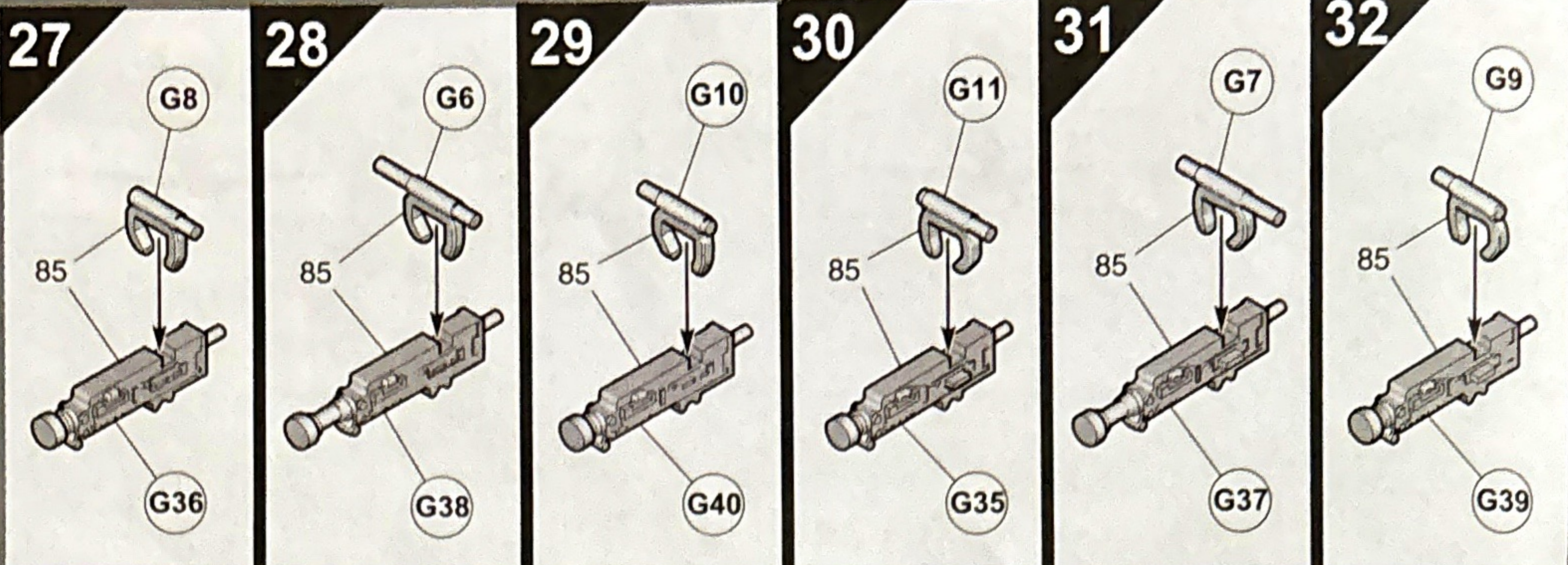

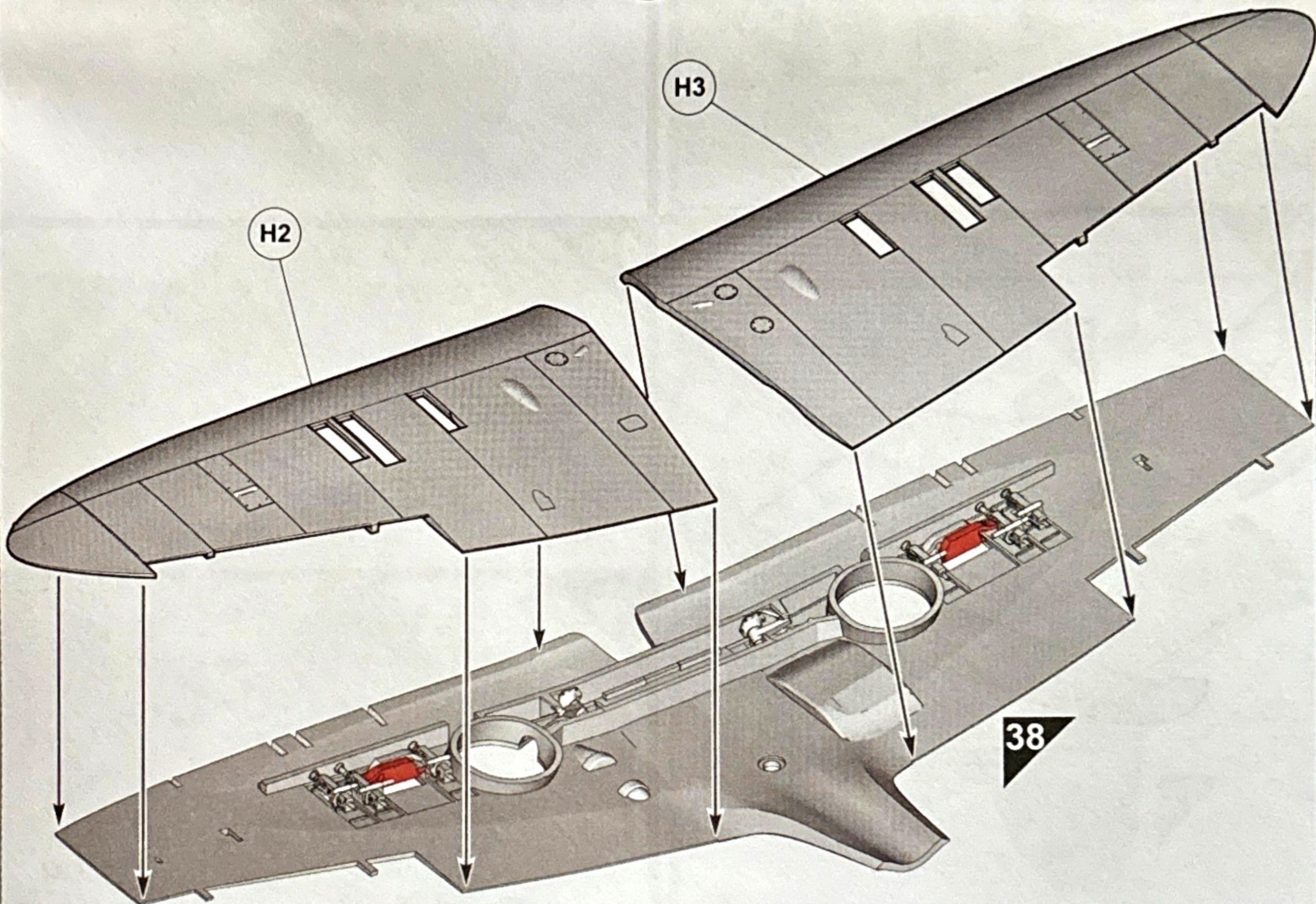
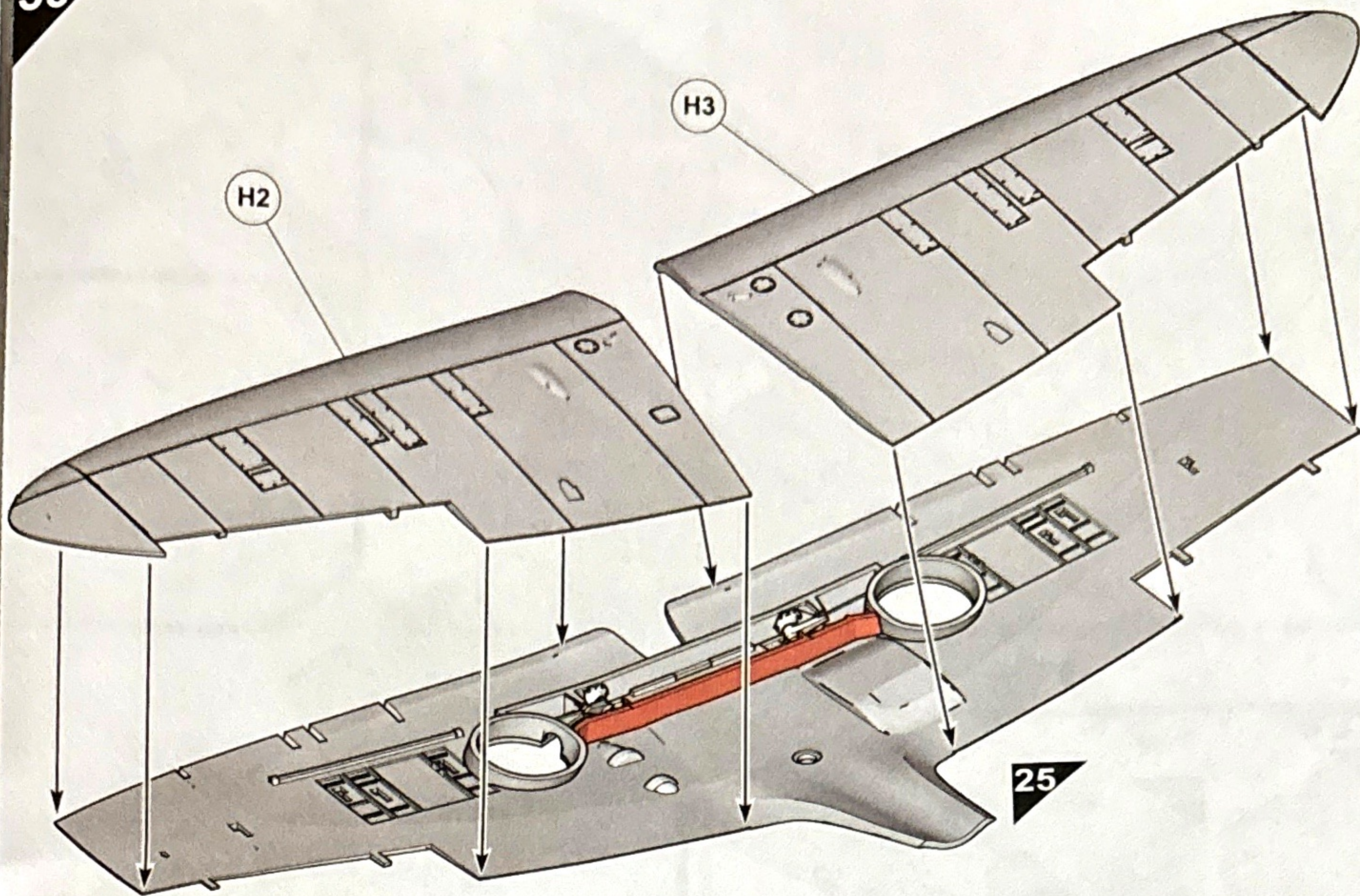

40

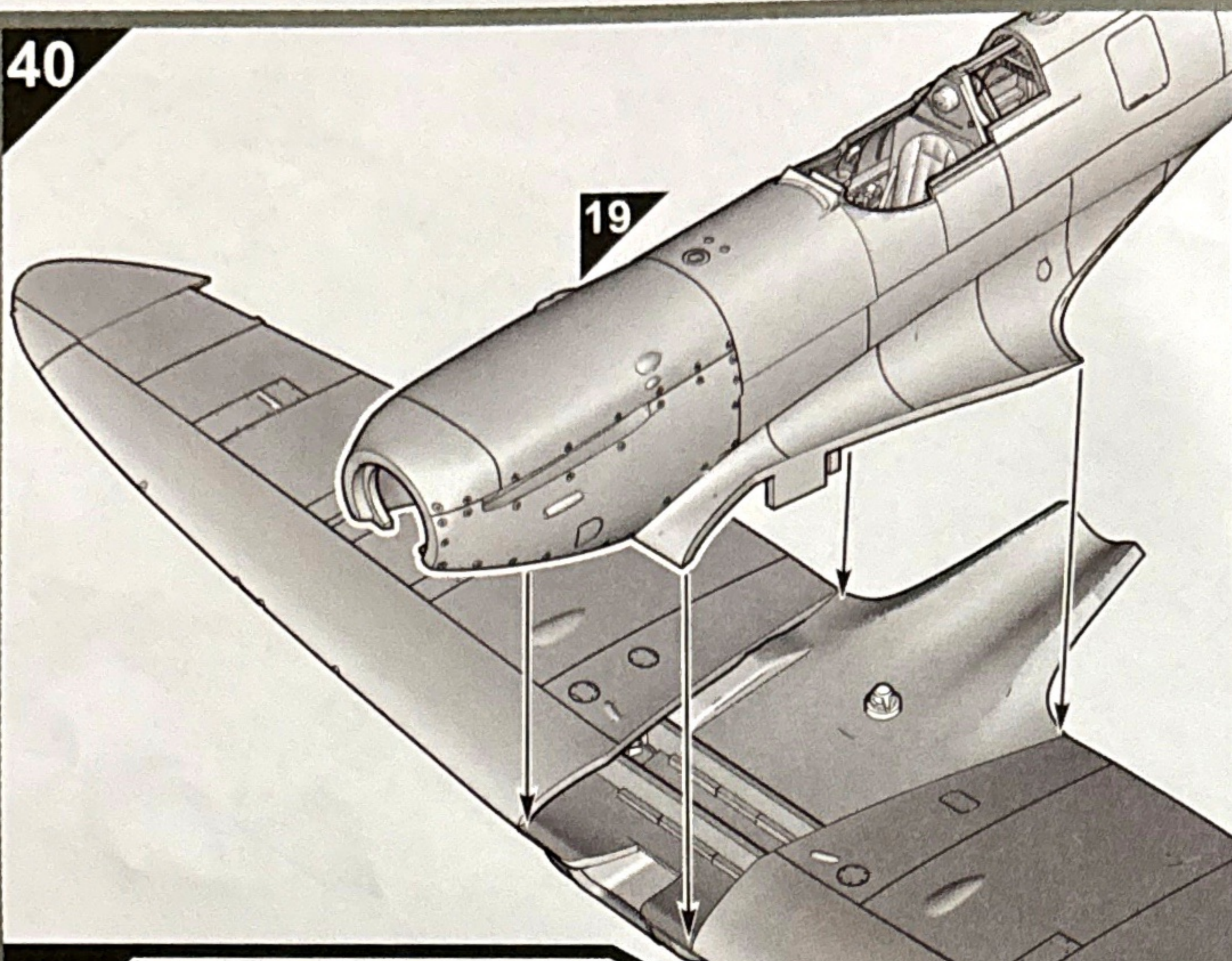

41

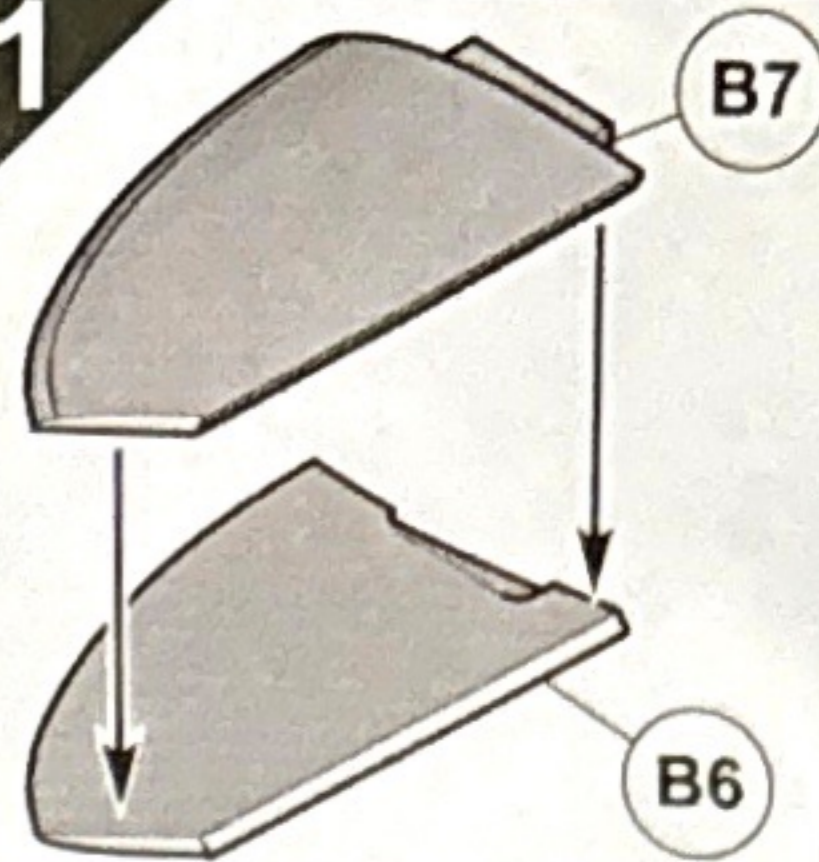

42

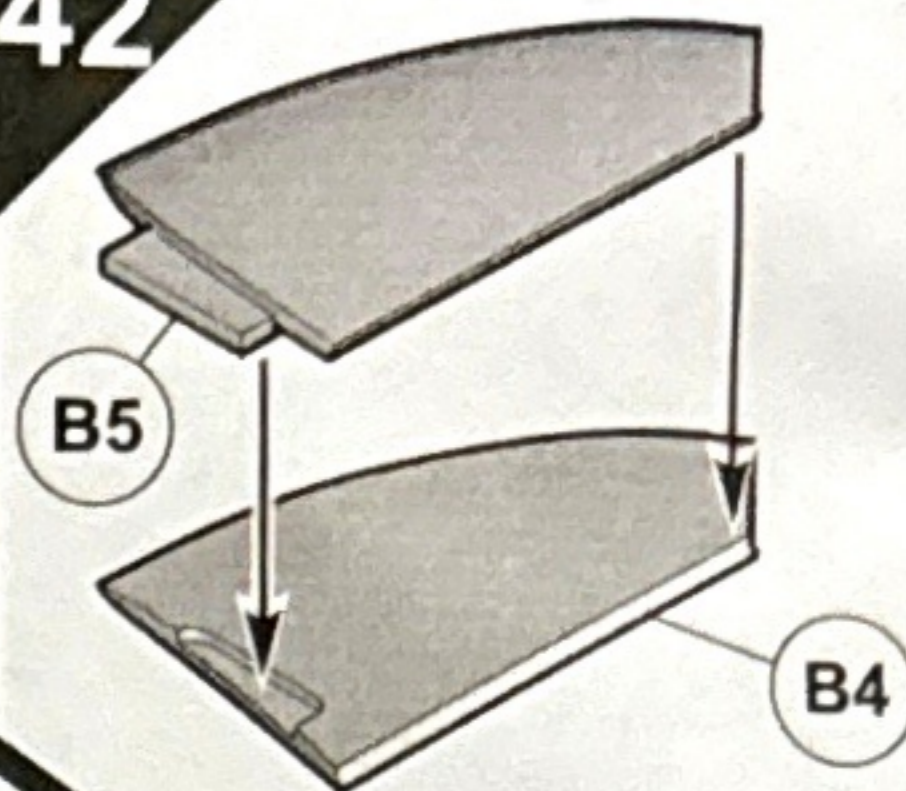

43

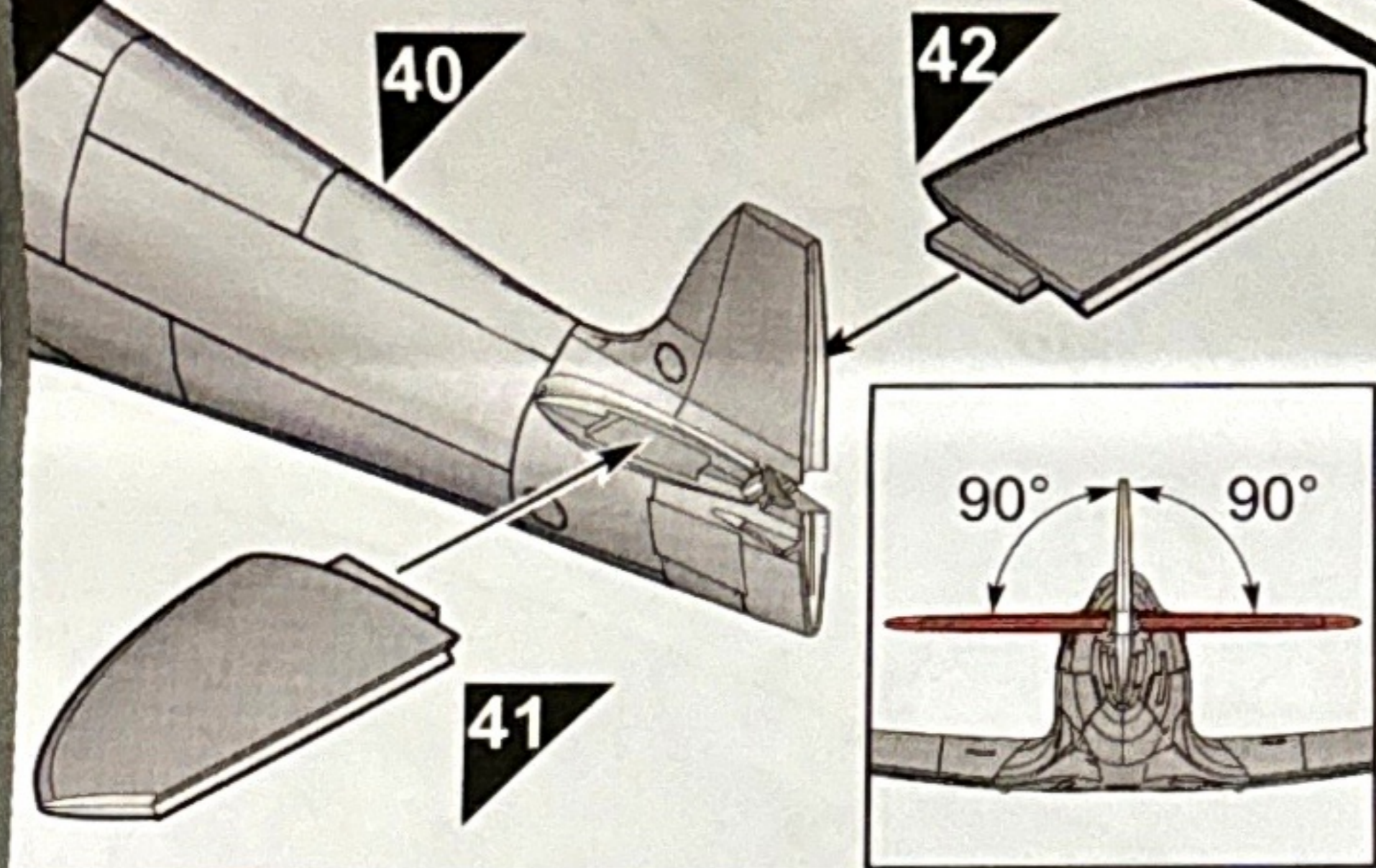

39

44

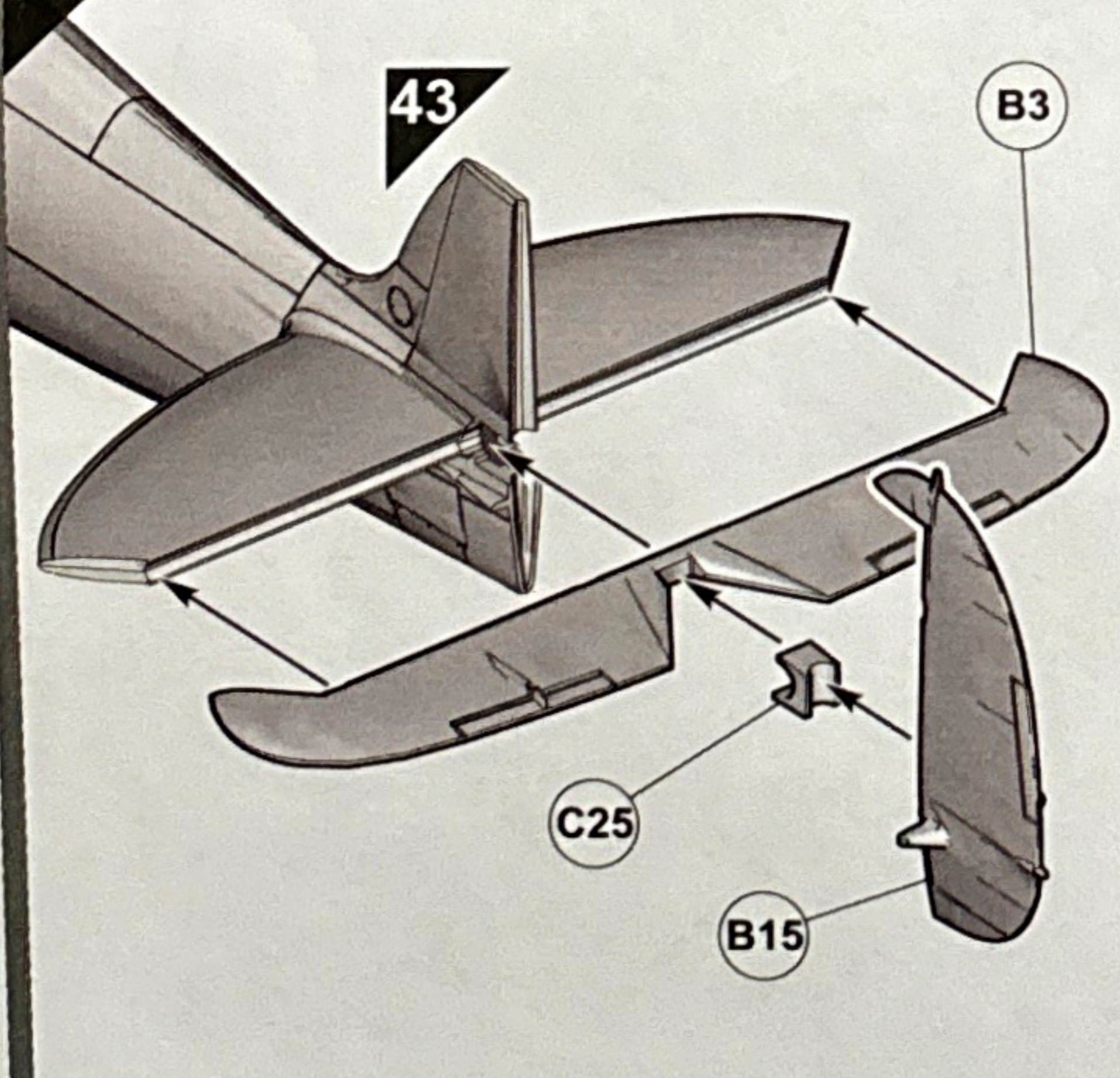

45

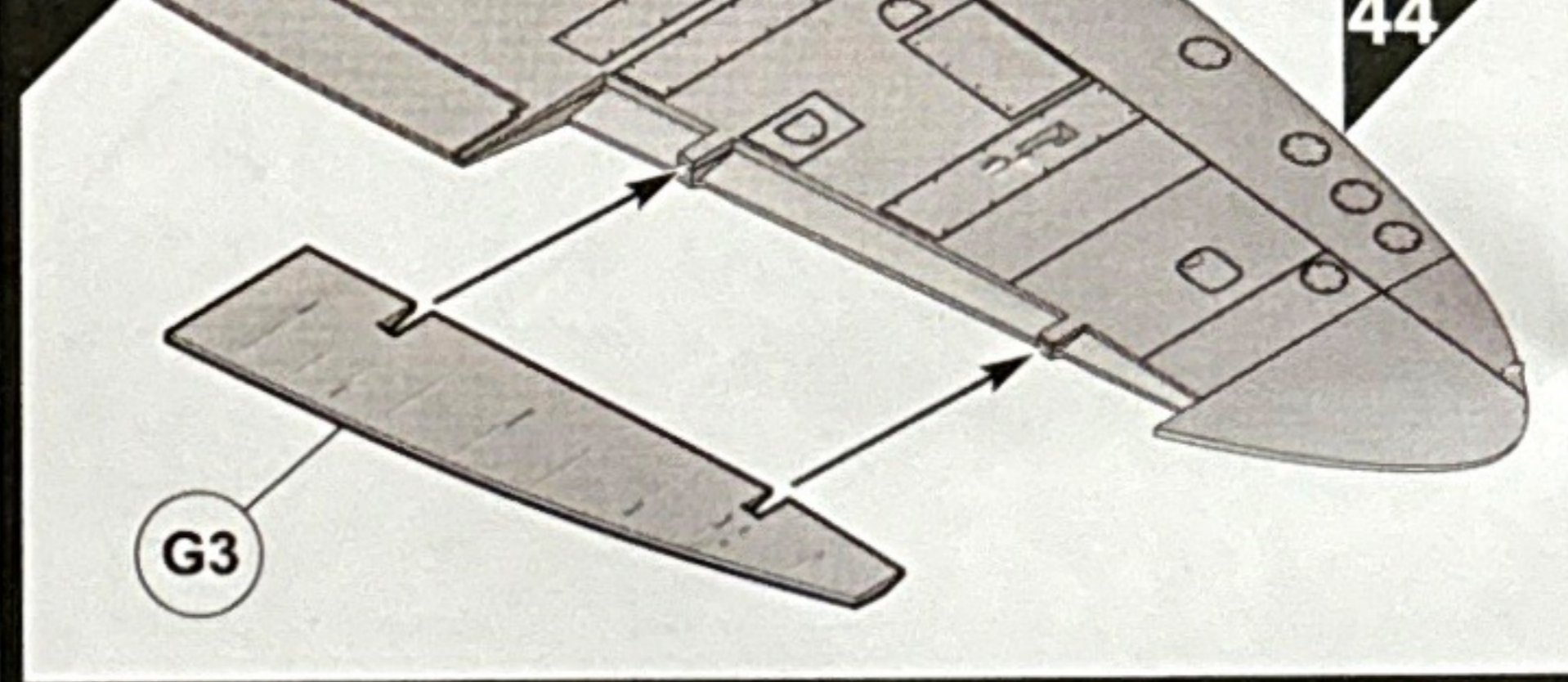

46

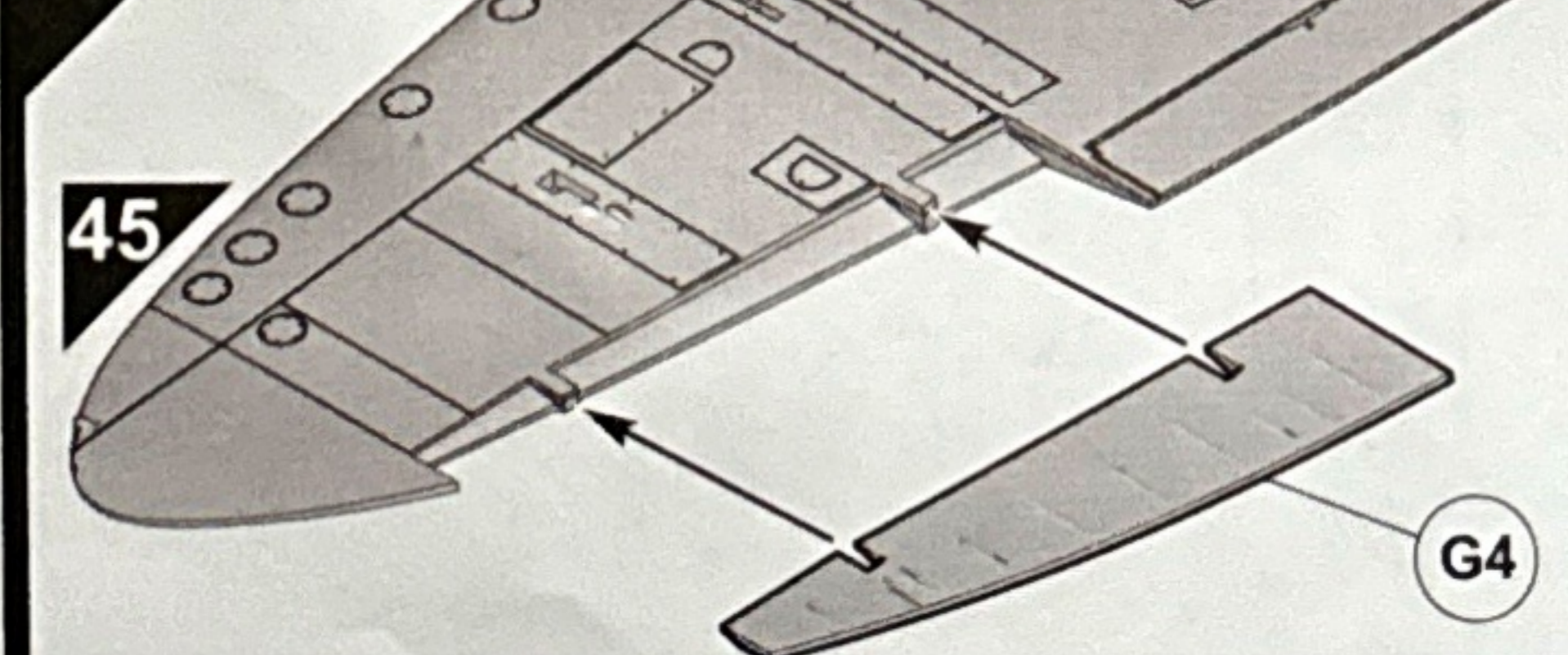

47

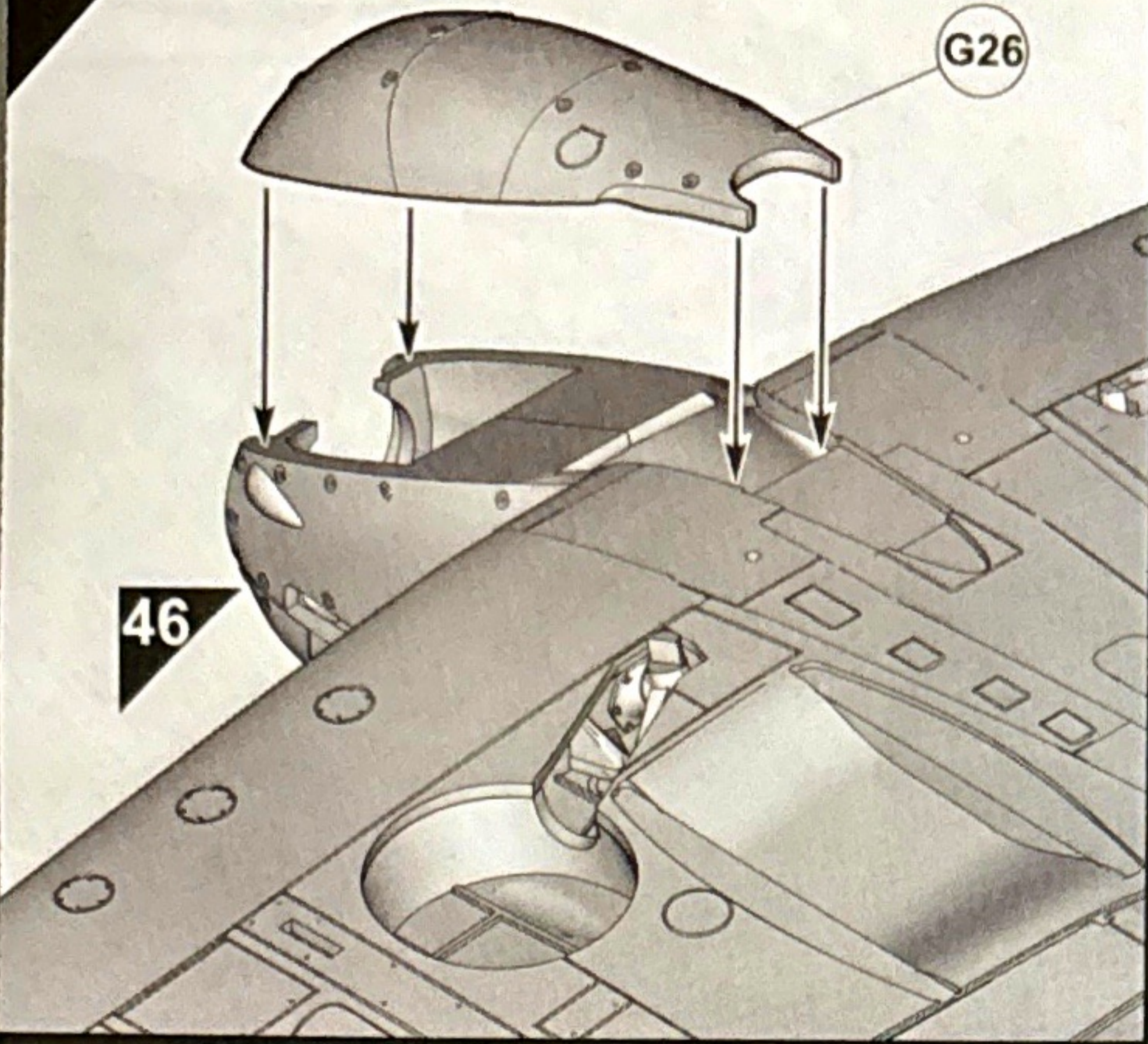

48

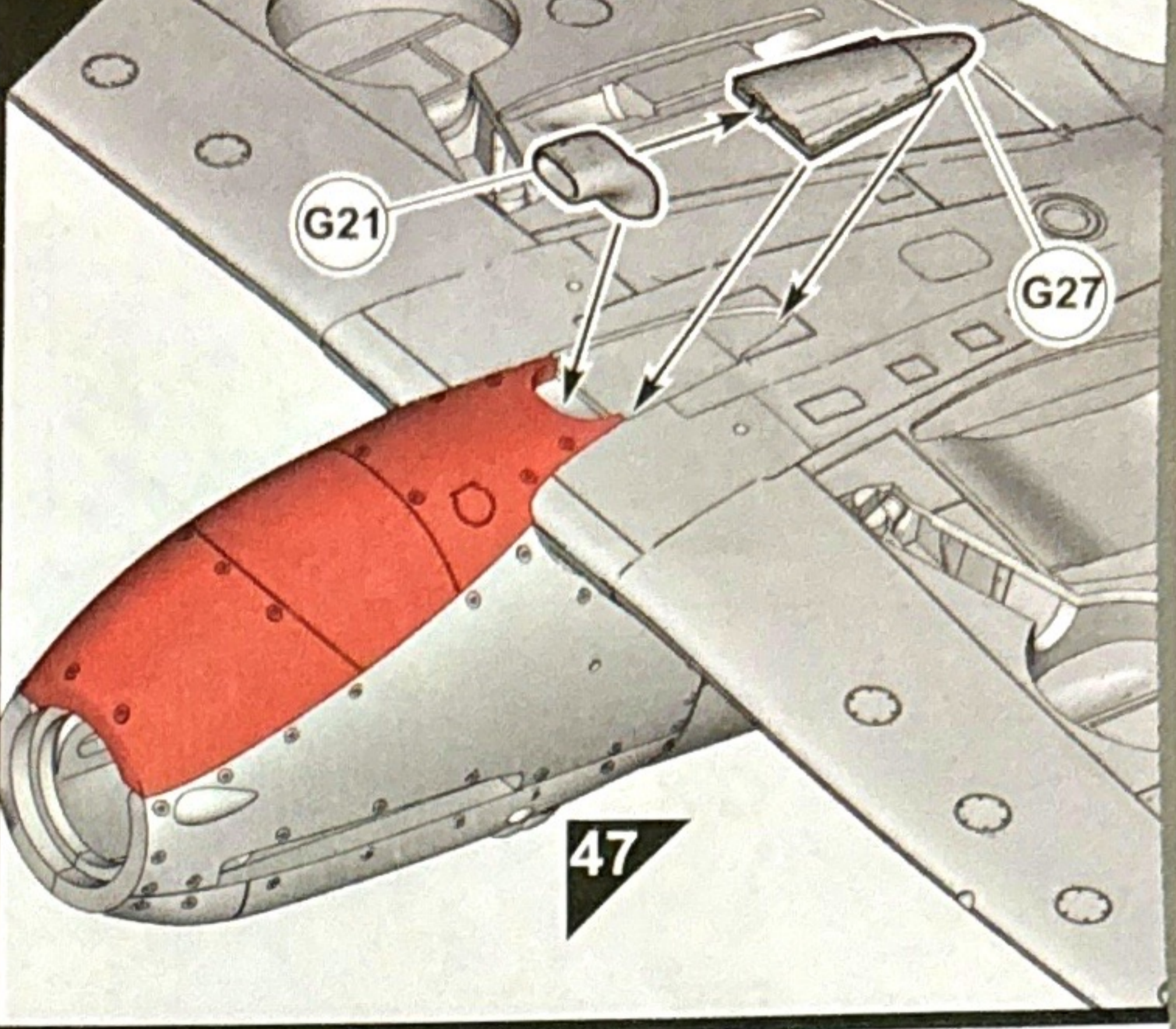

49

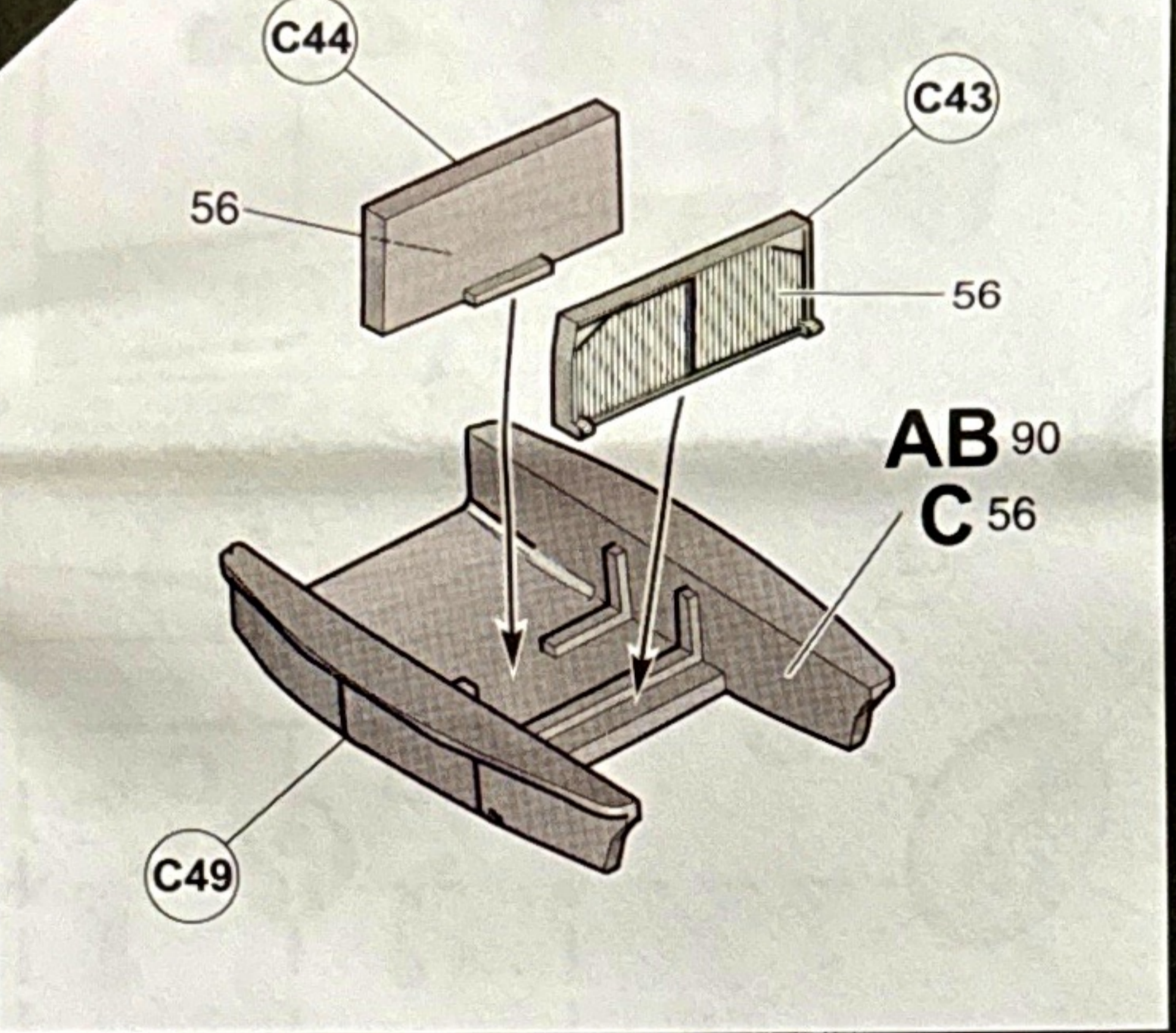

50

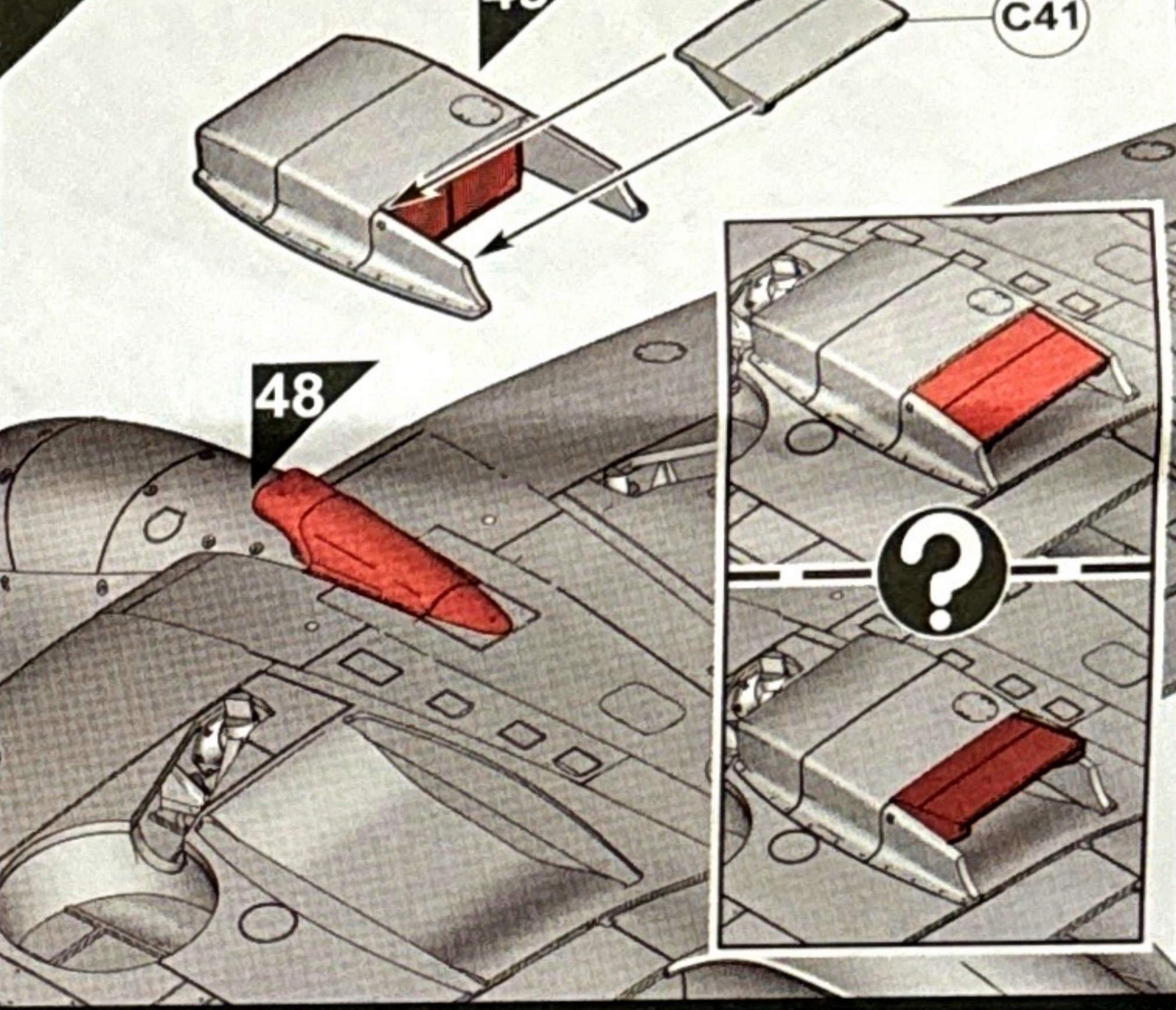

51

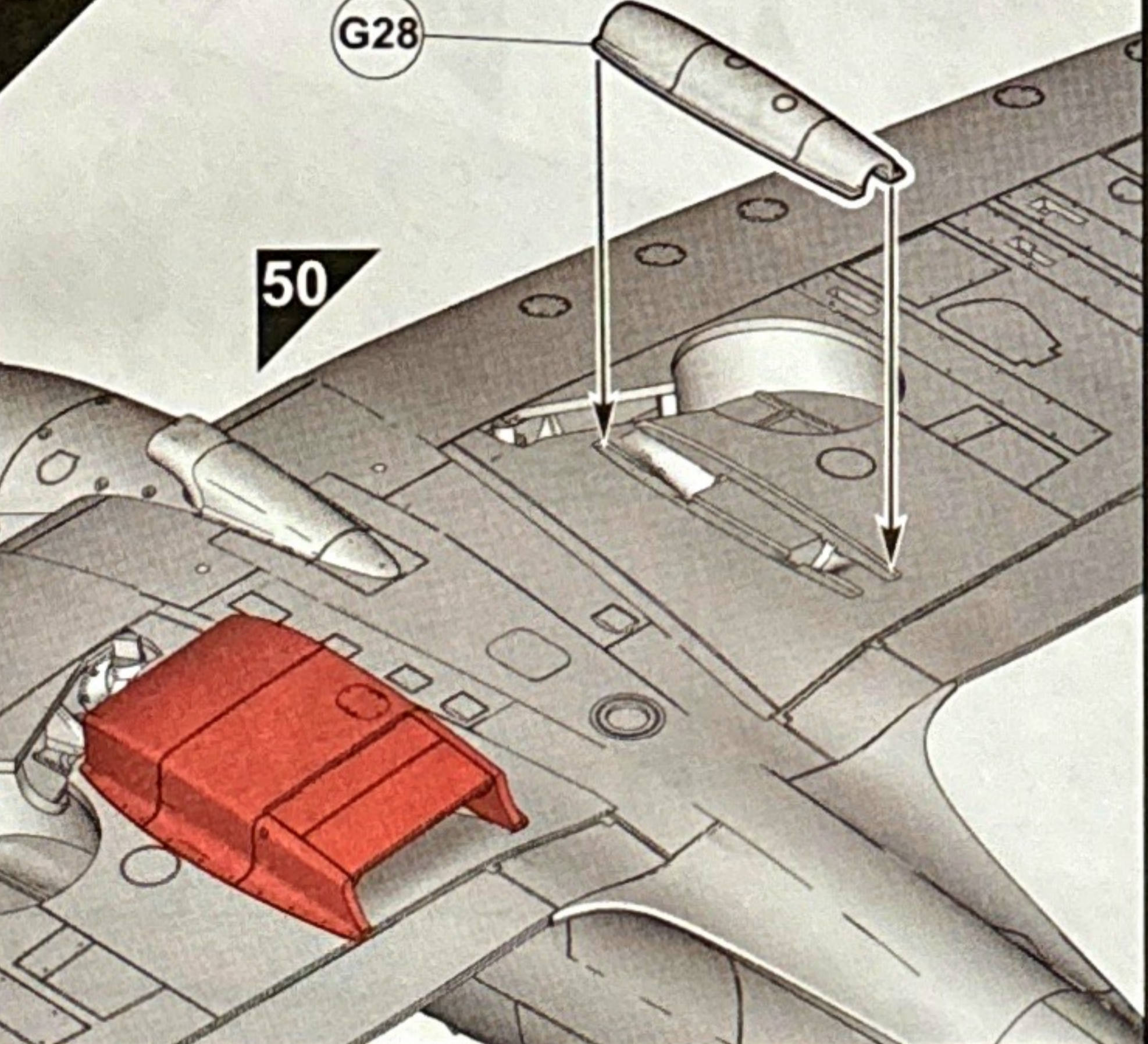

52

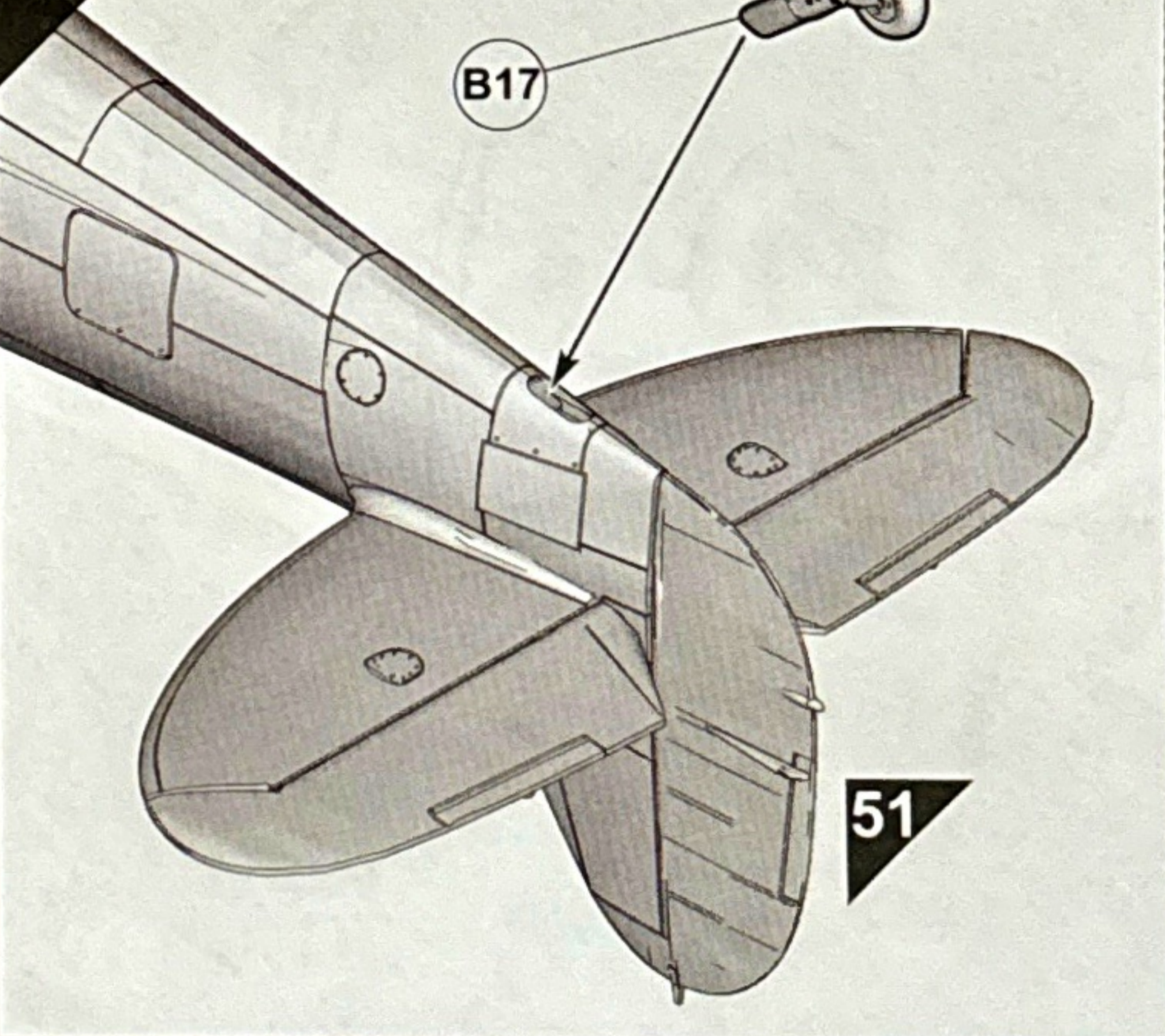

53

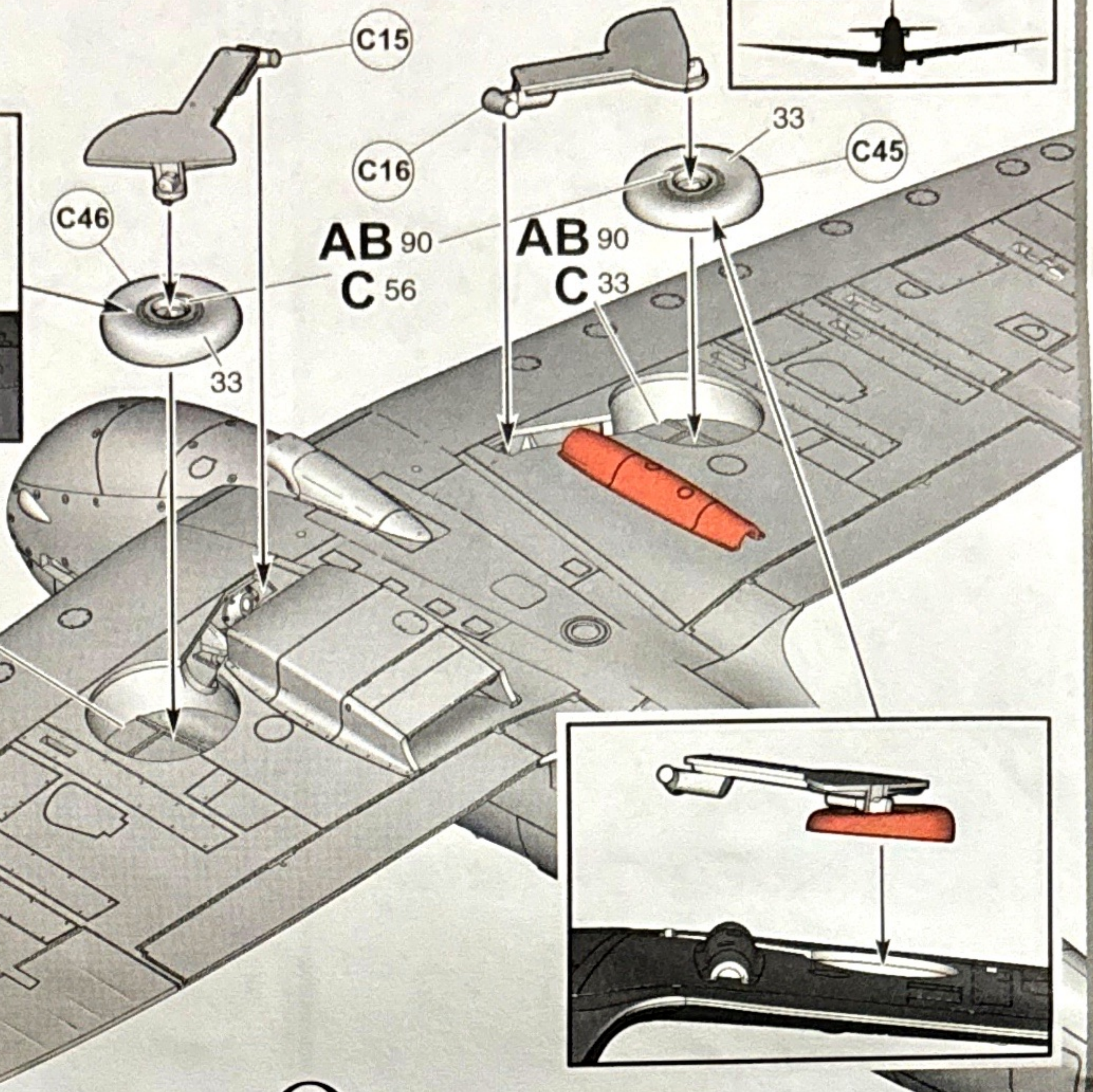
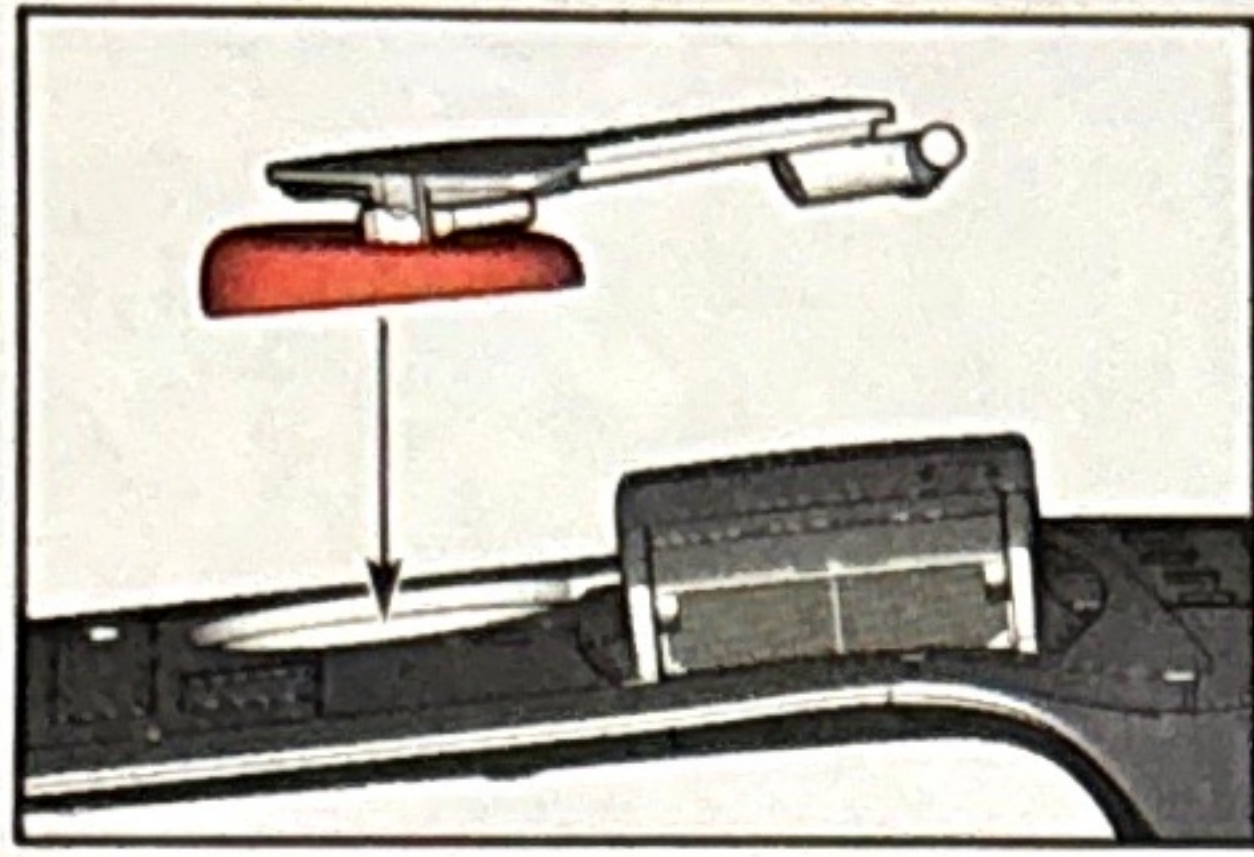

AB 90
C 34

52

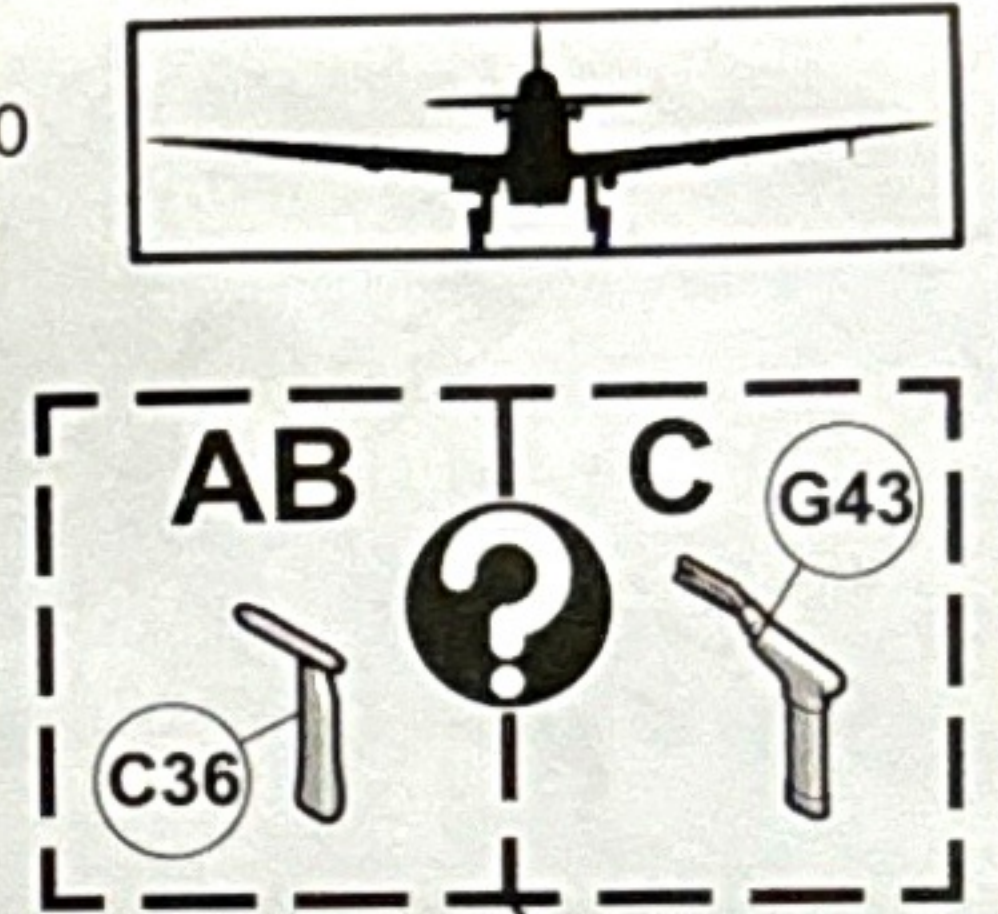
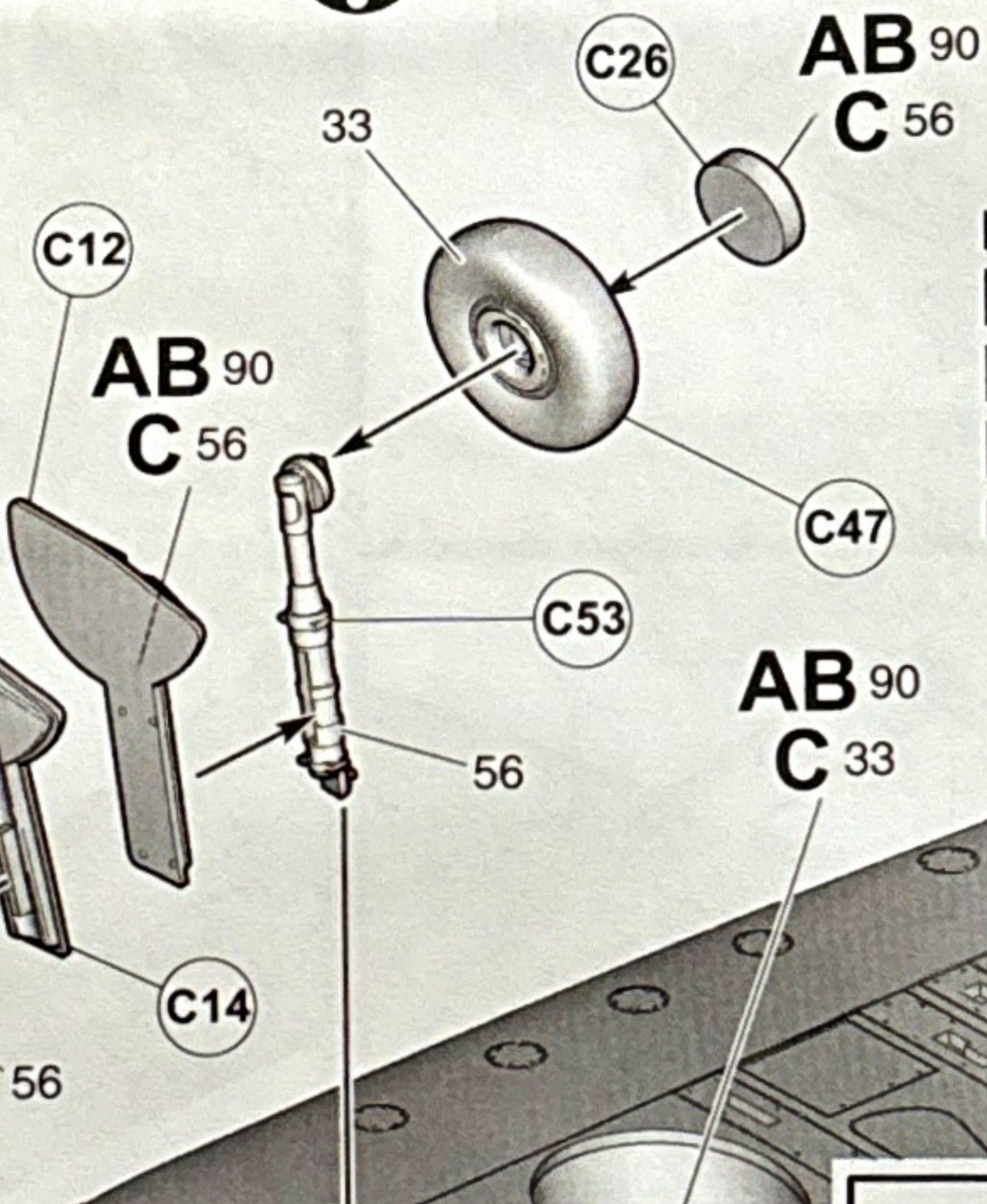
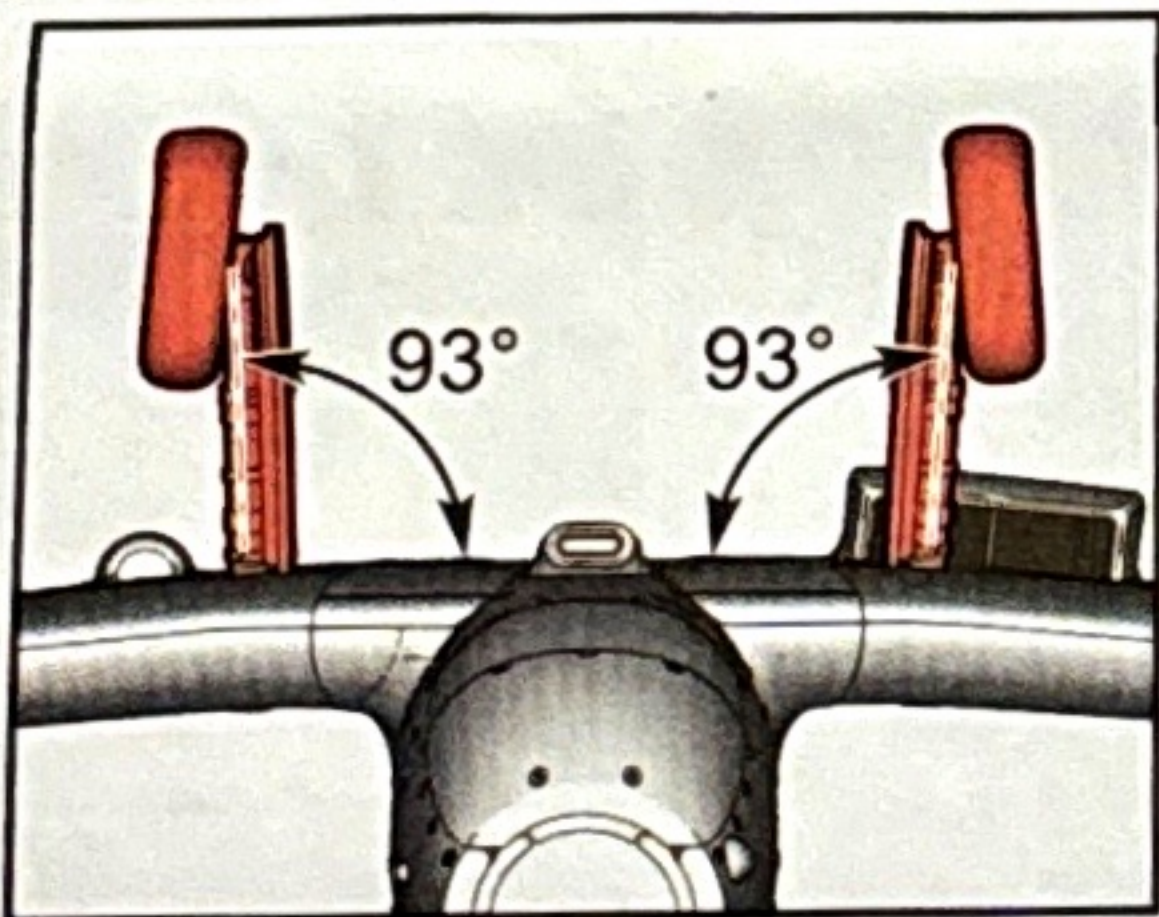
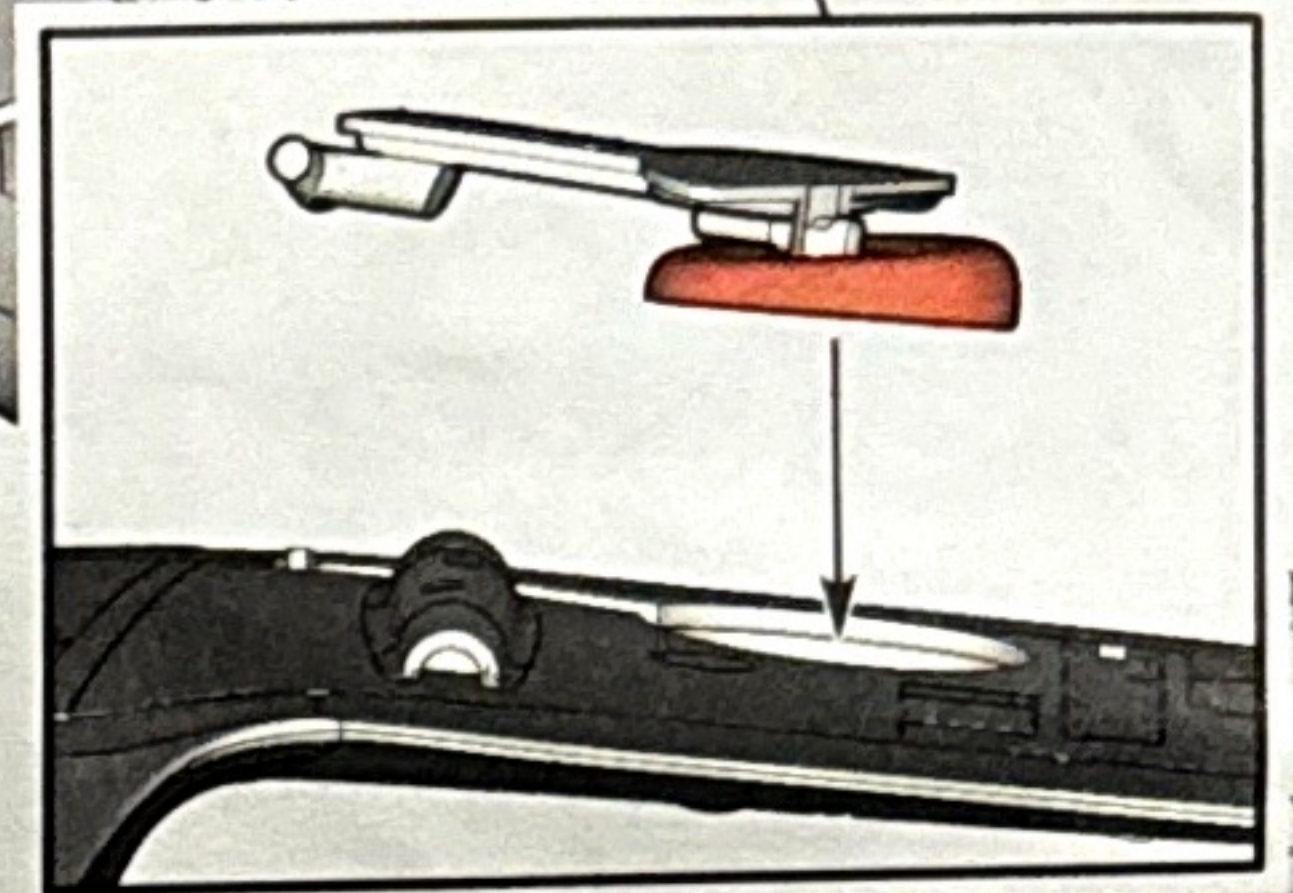

52

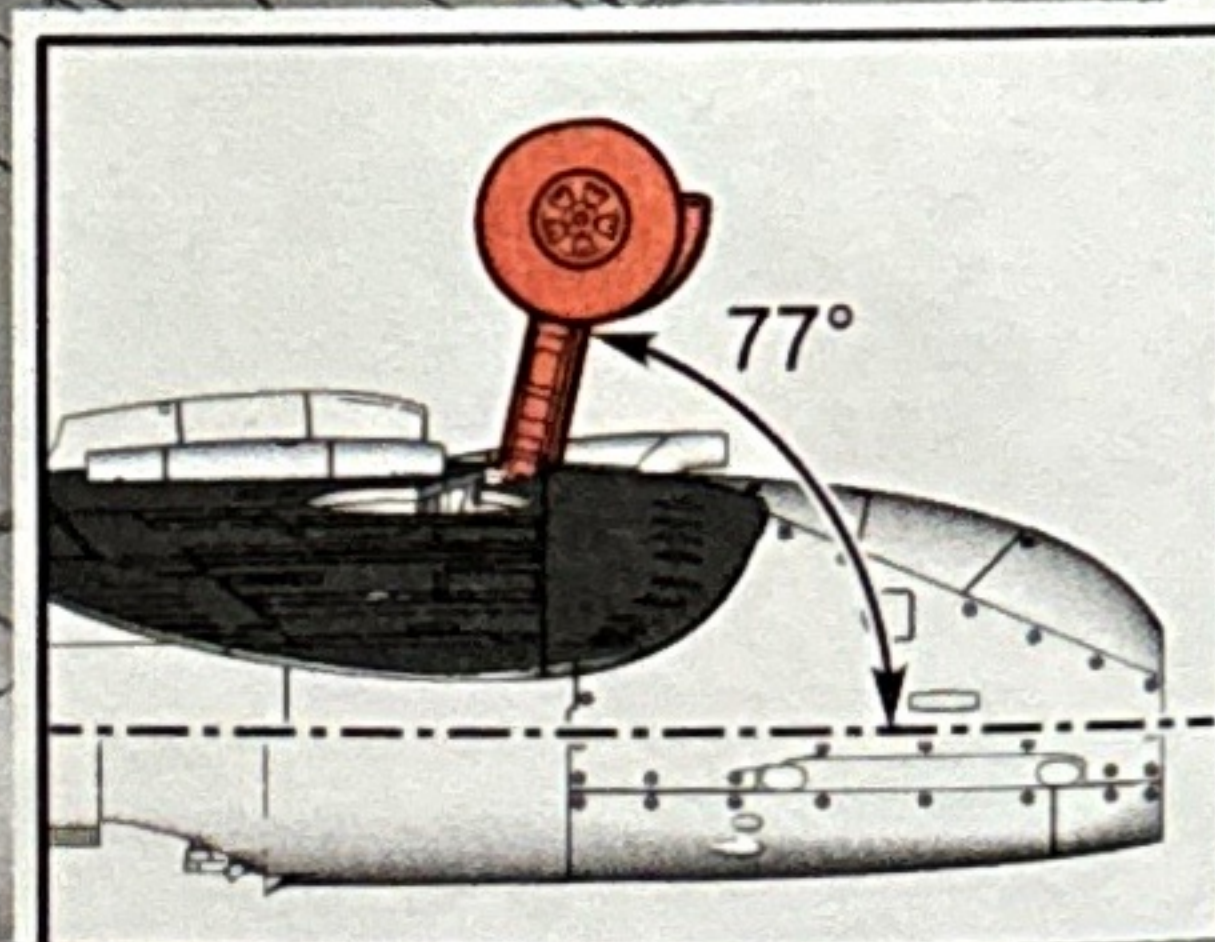
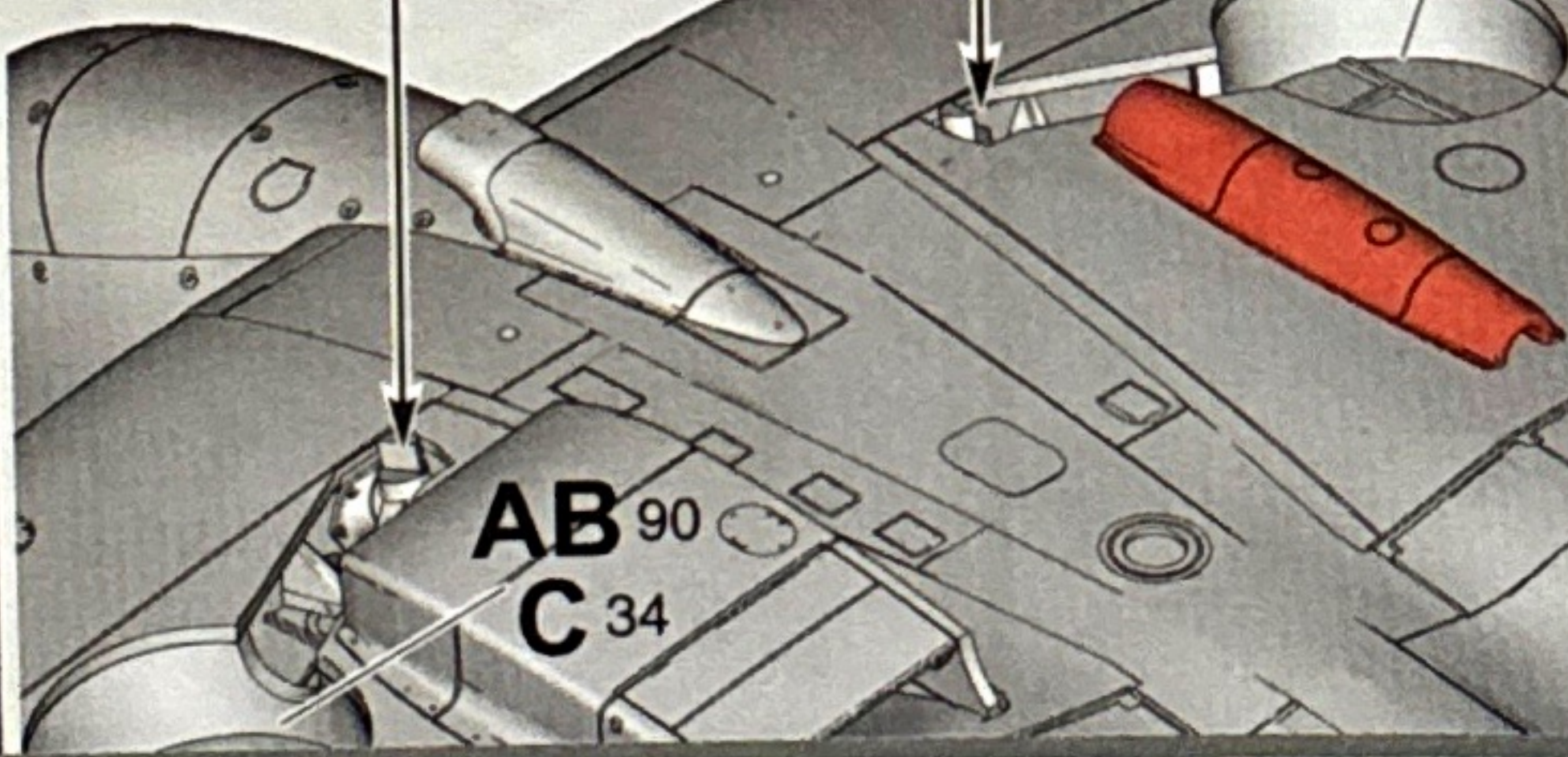
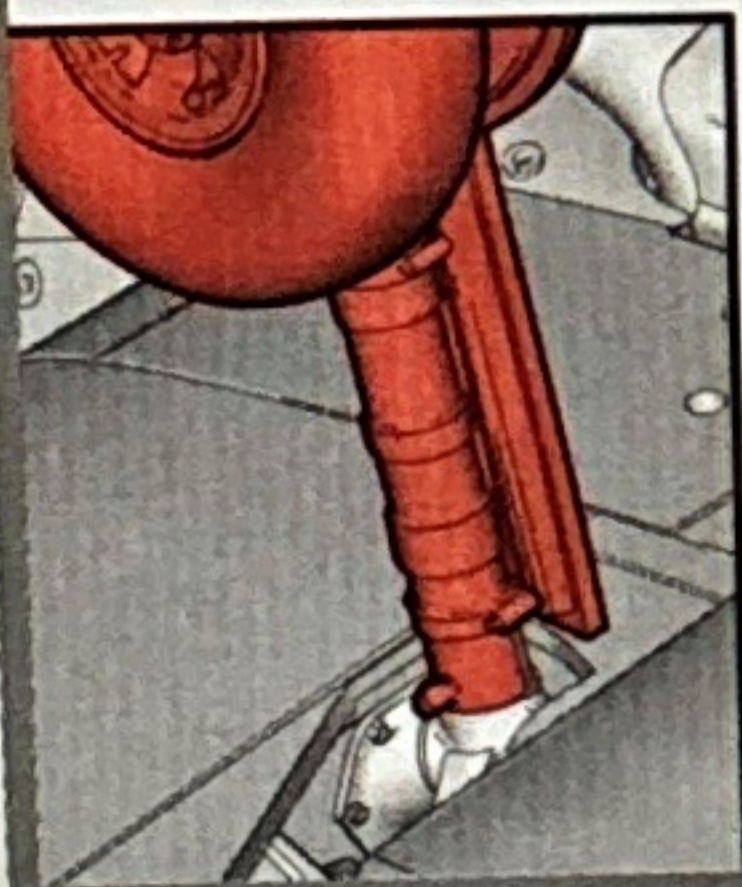

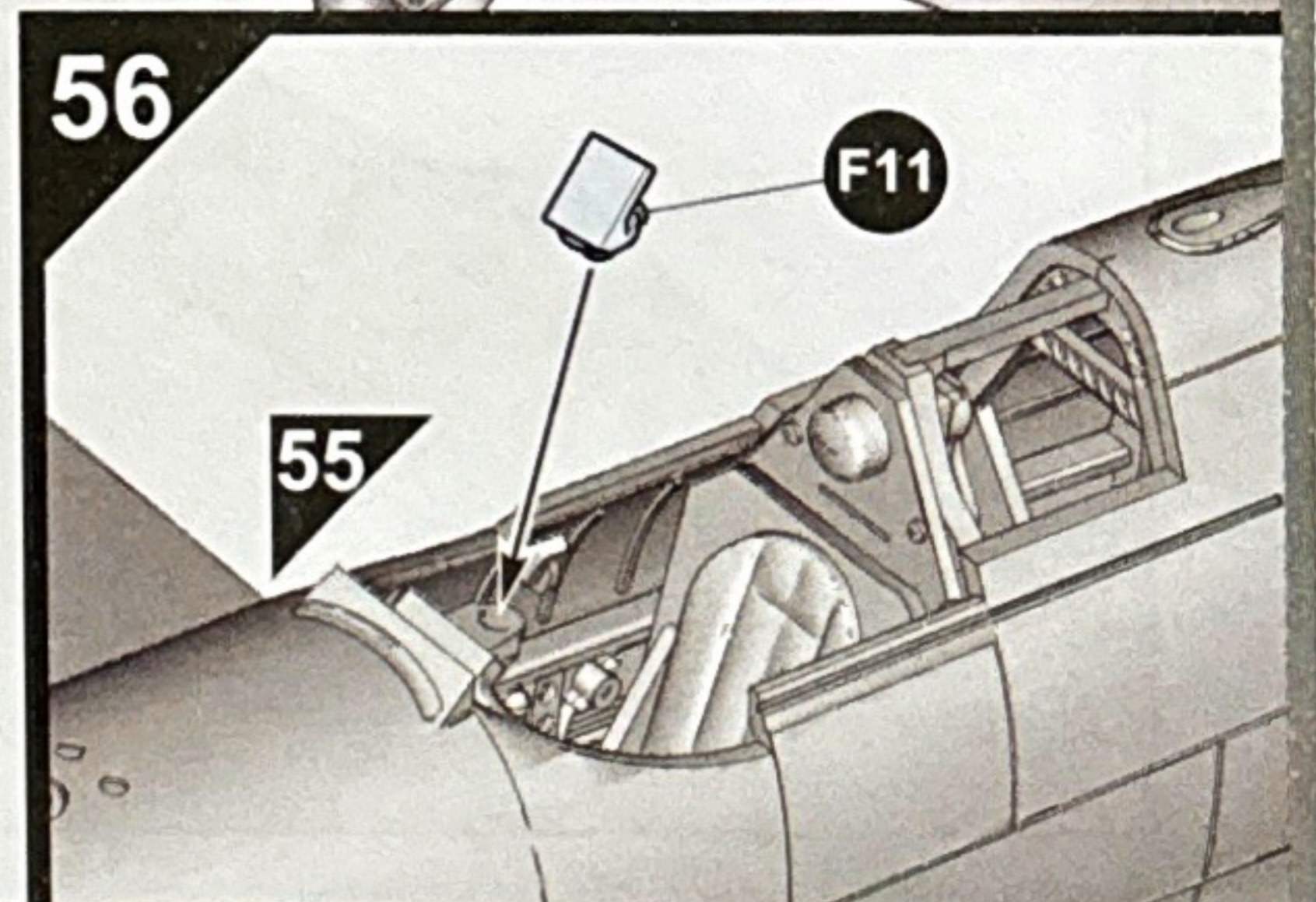
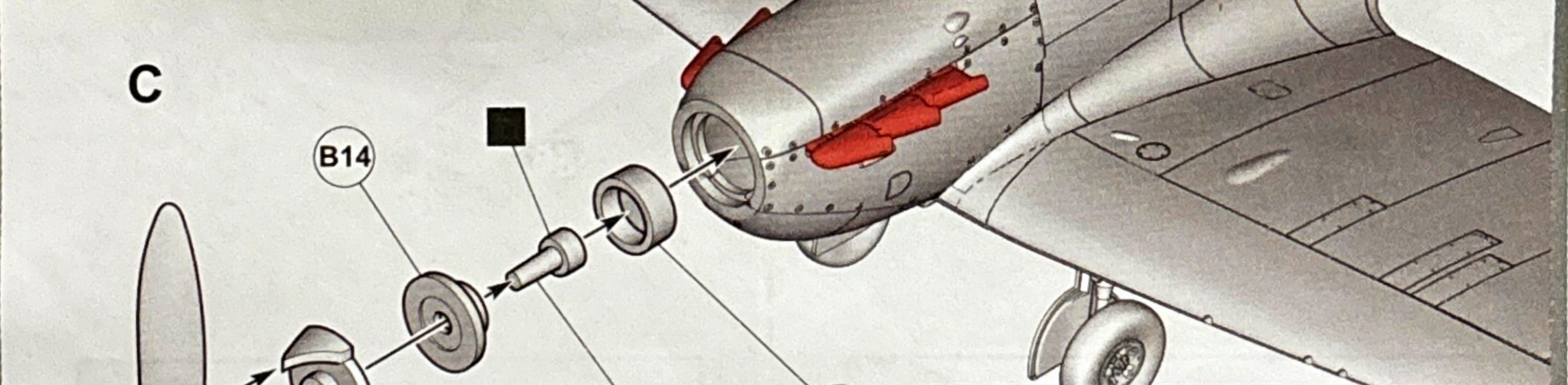
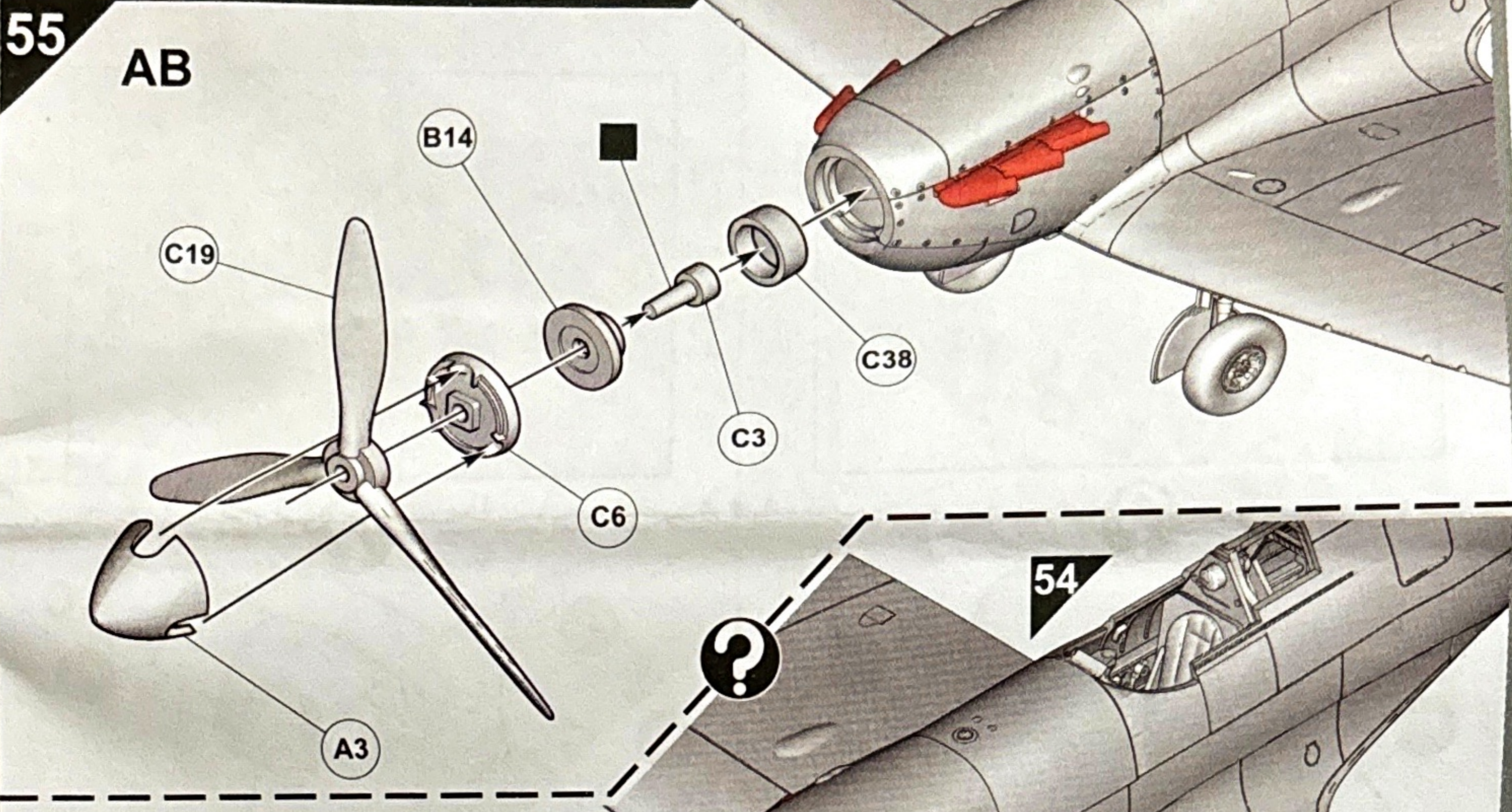
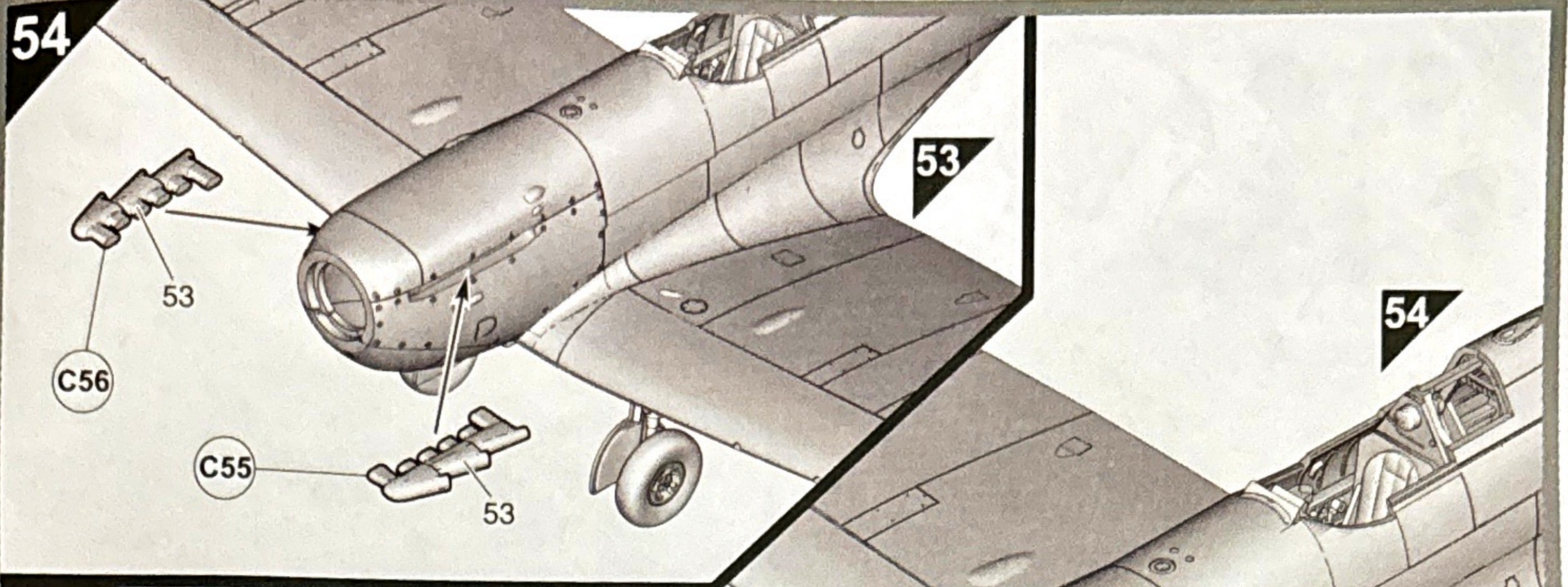

57

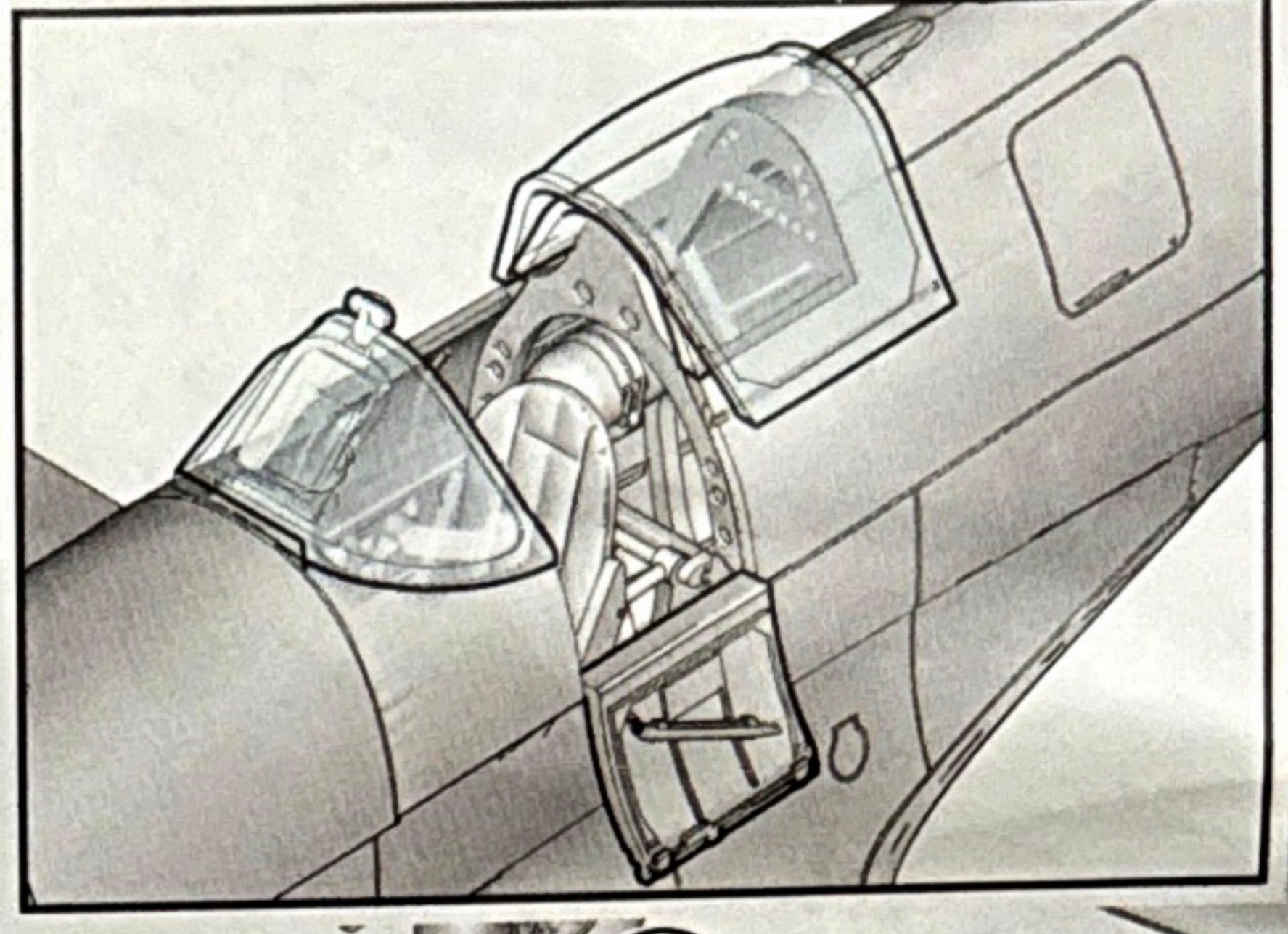
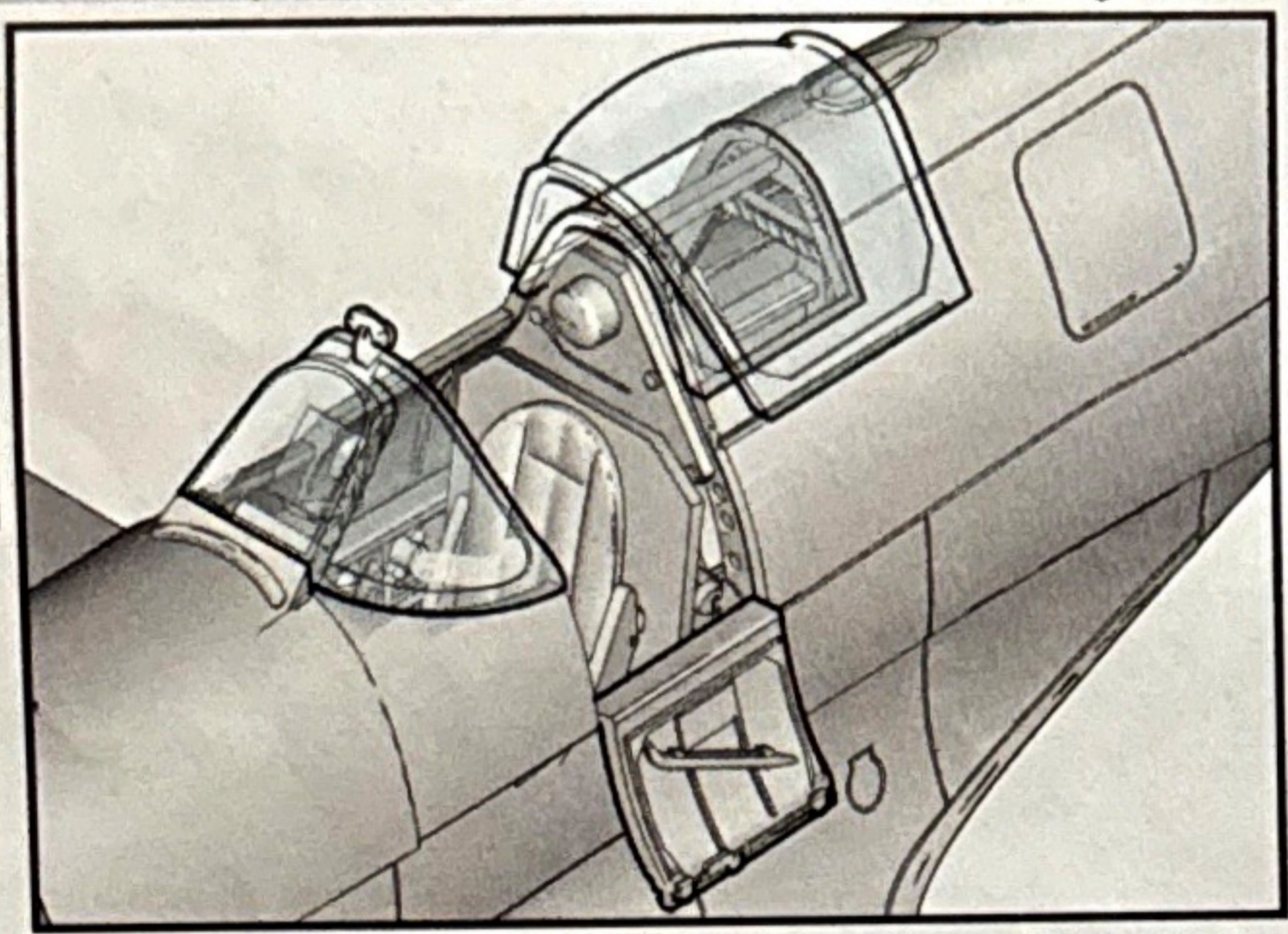
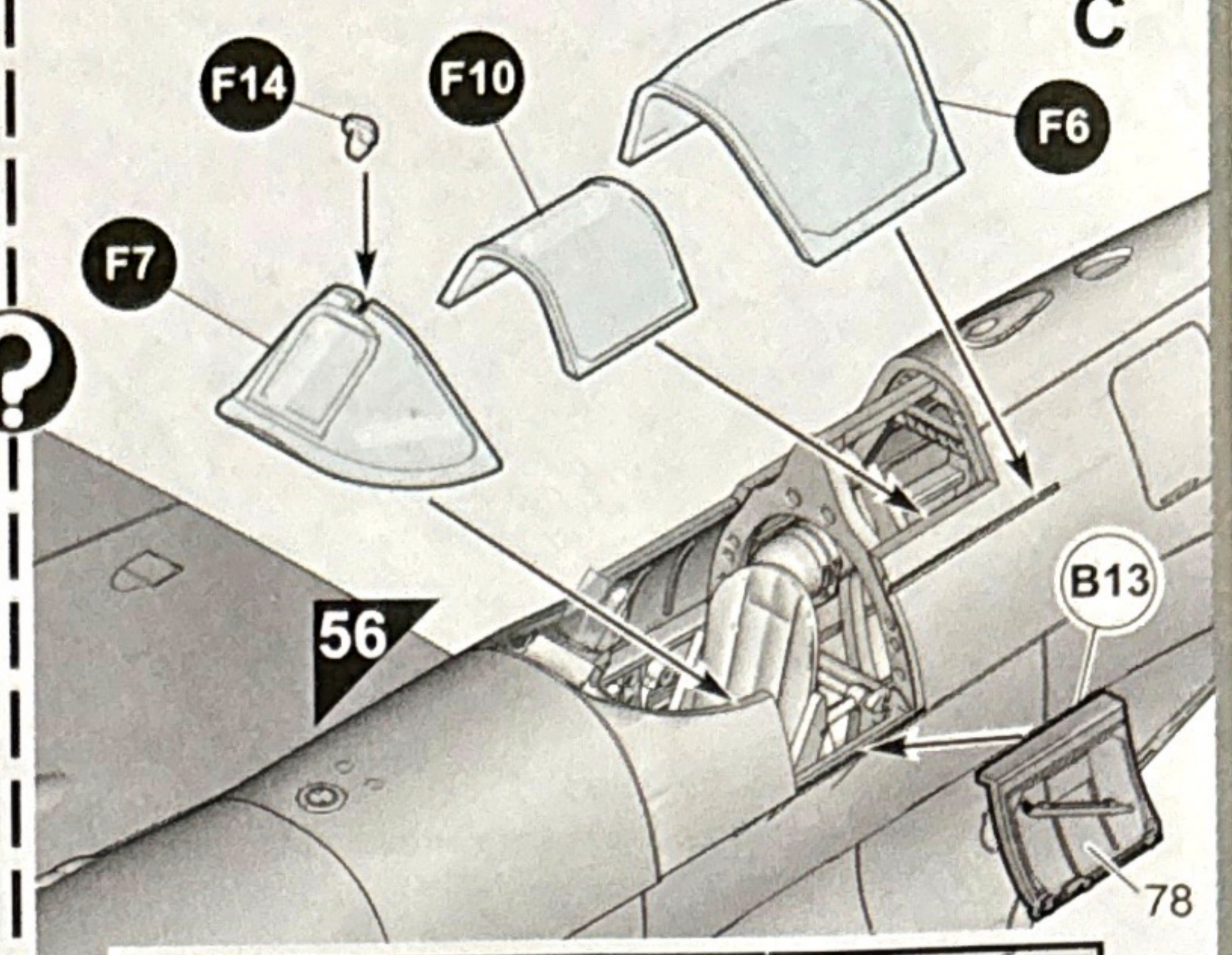
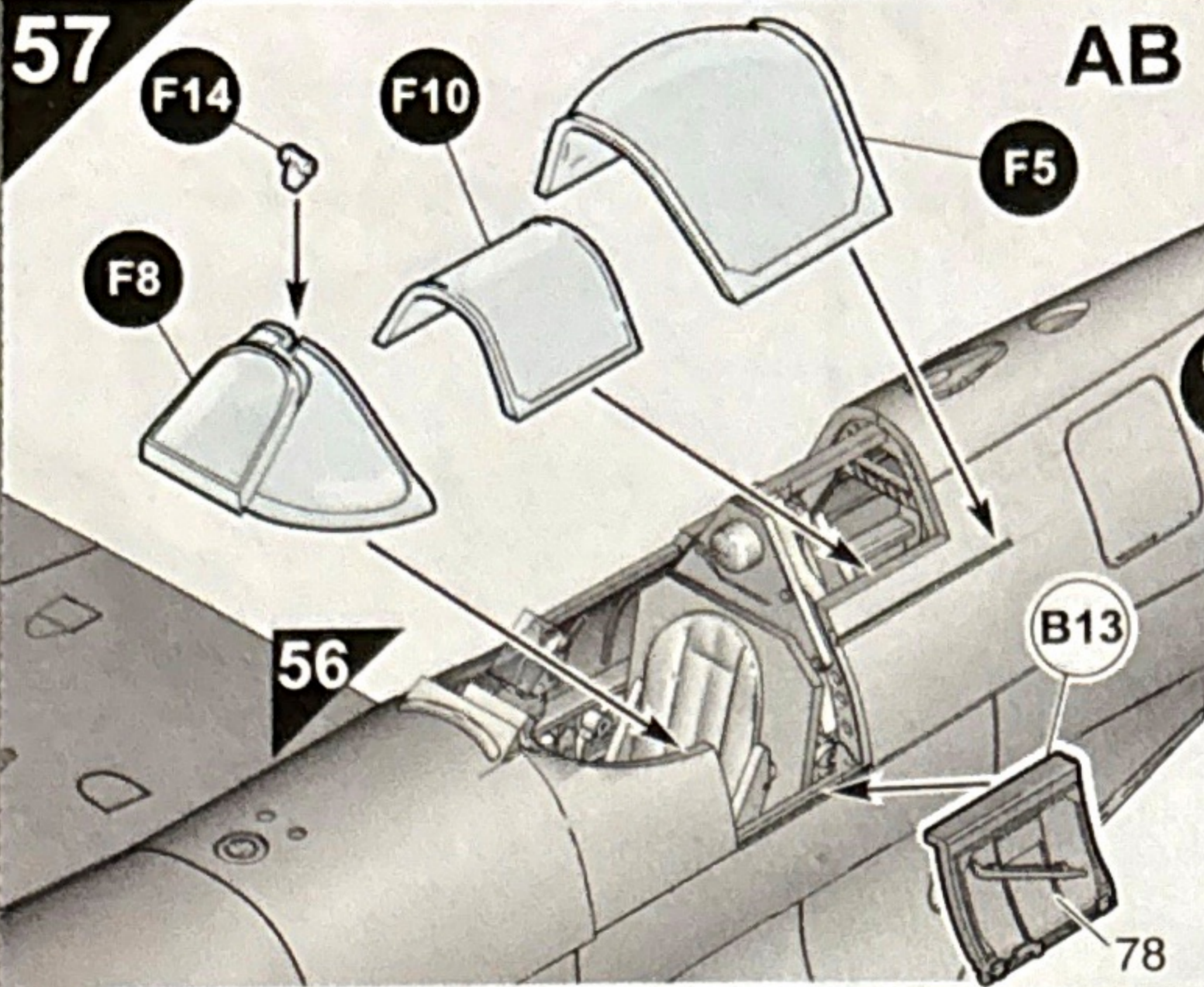

?

?

AB

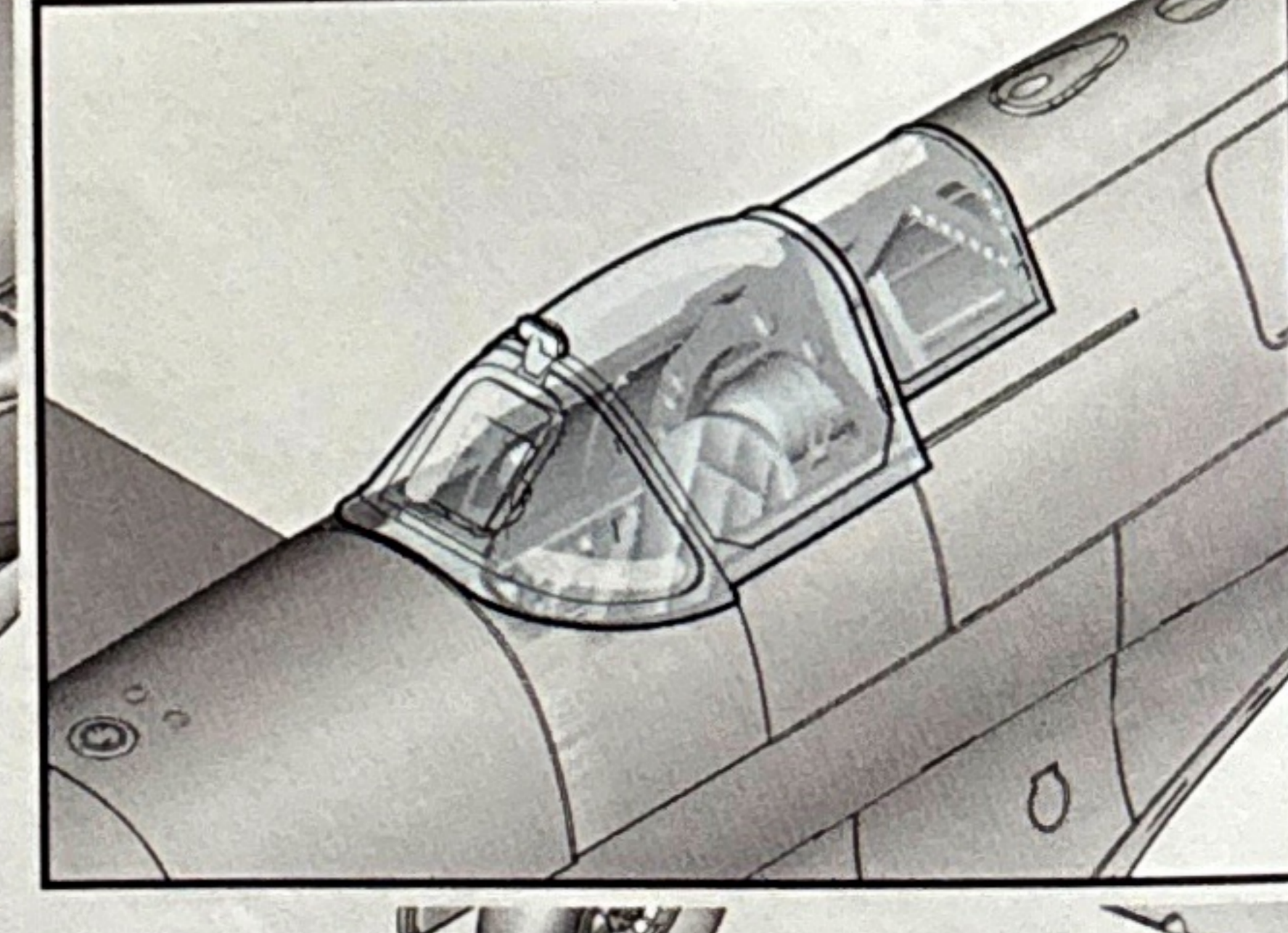
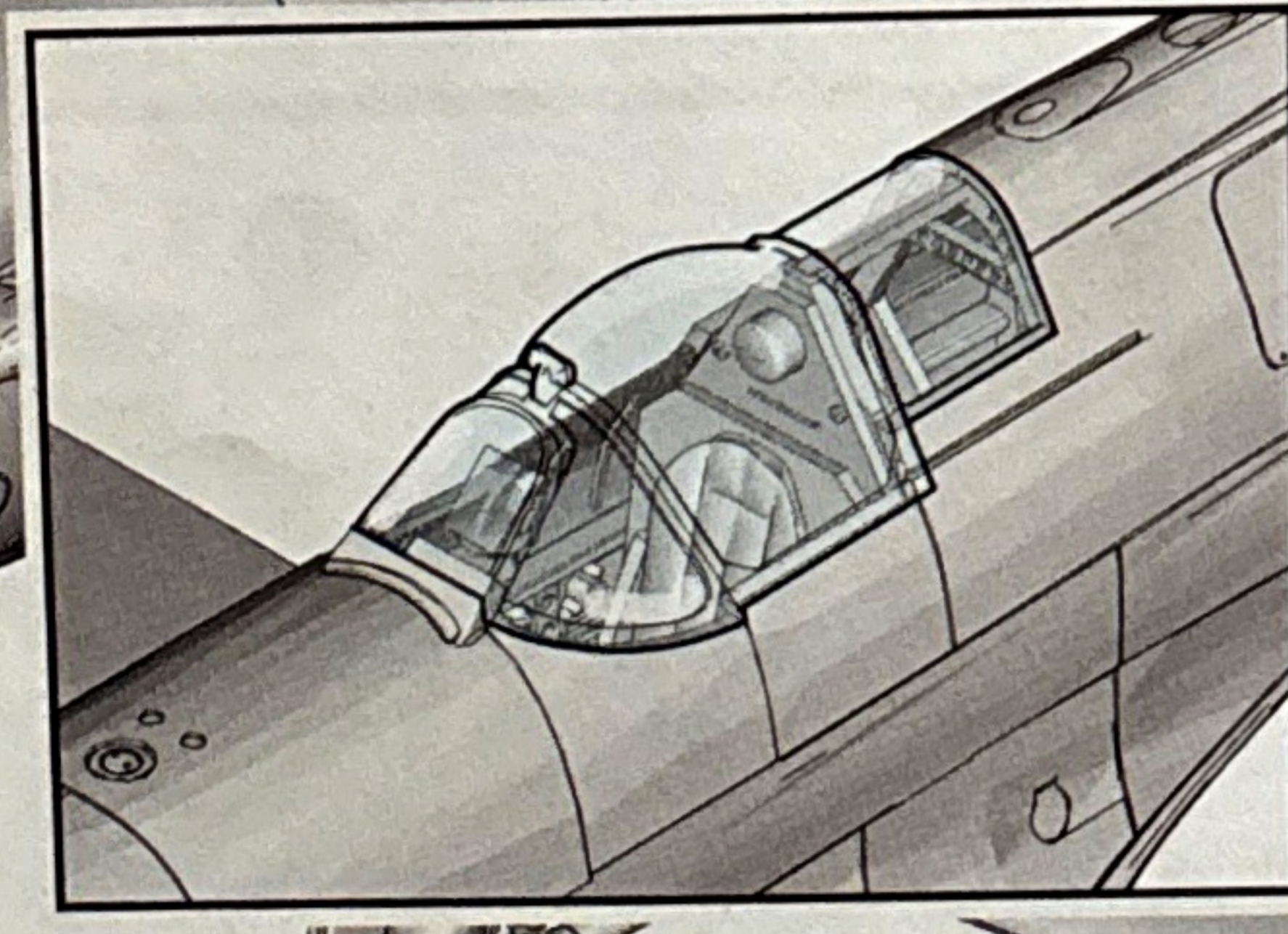
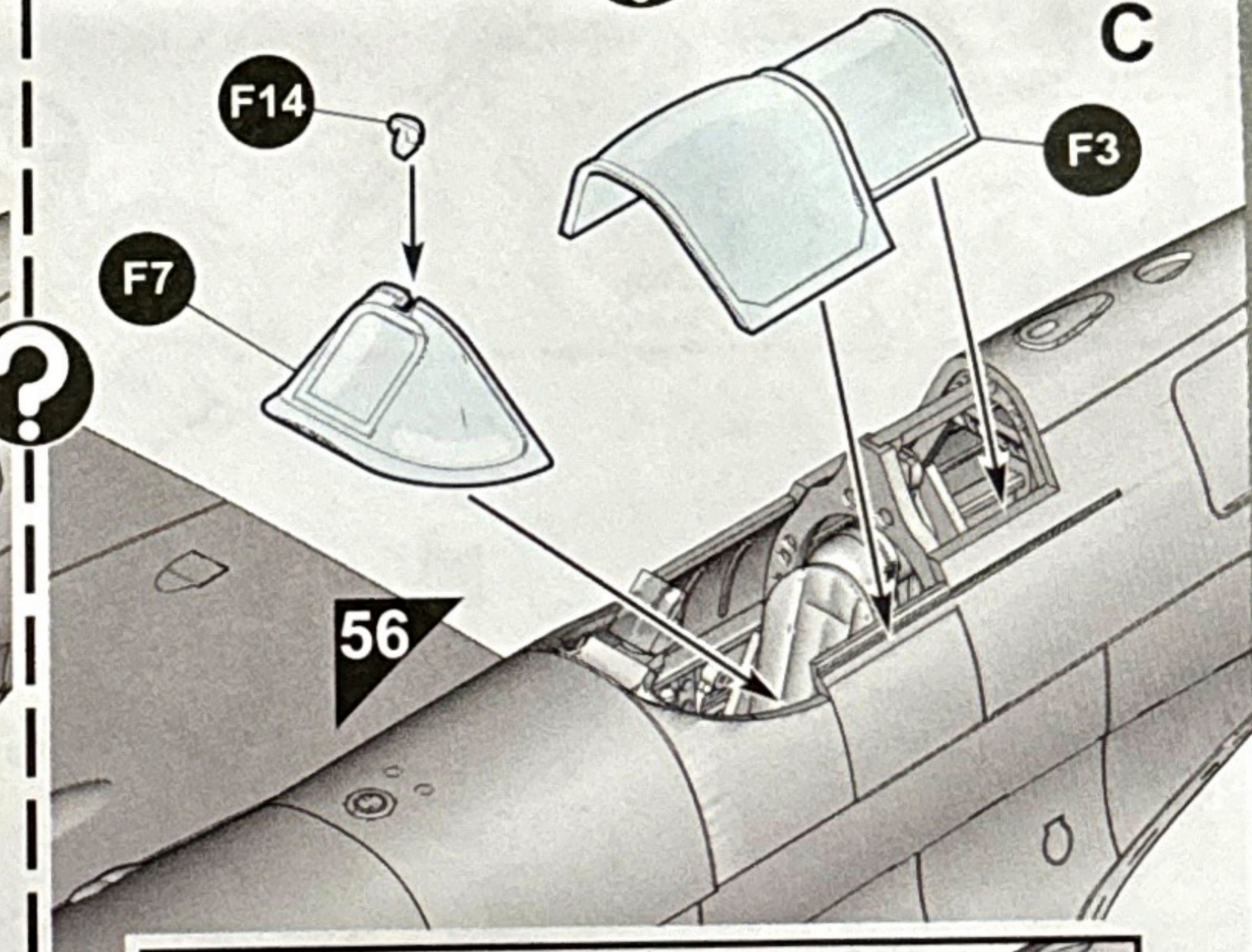
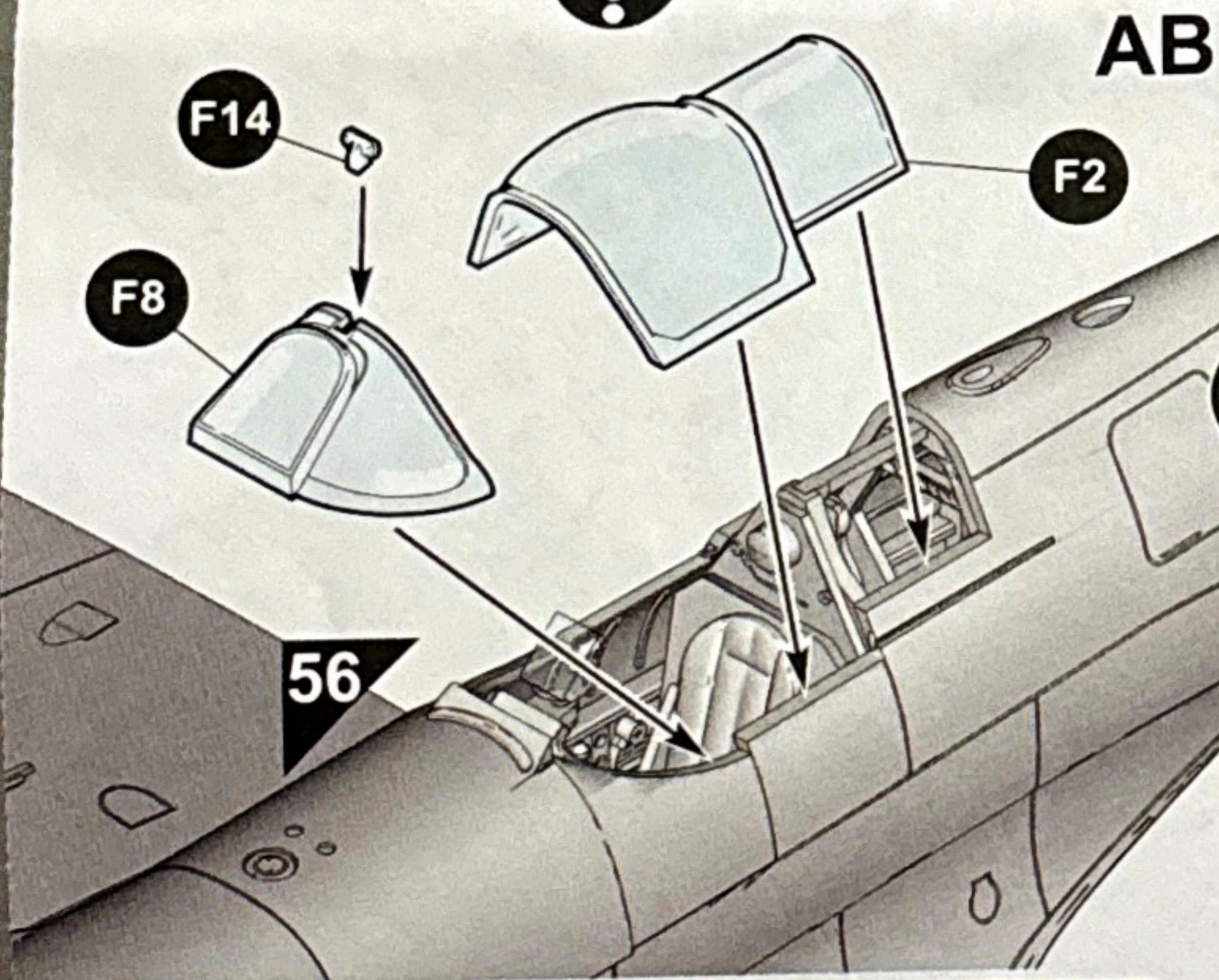

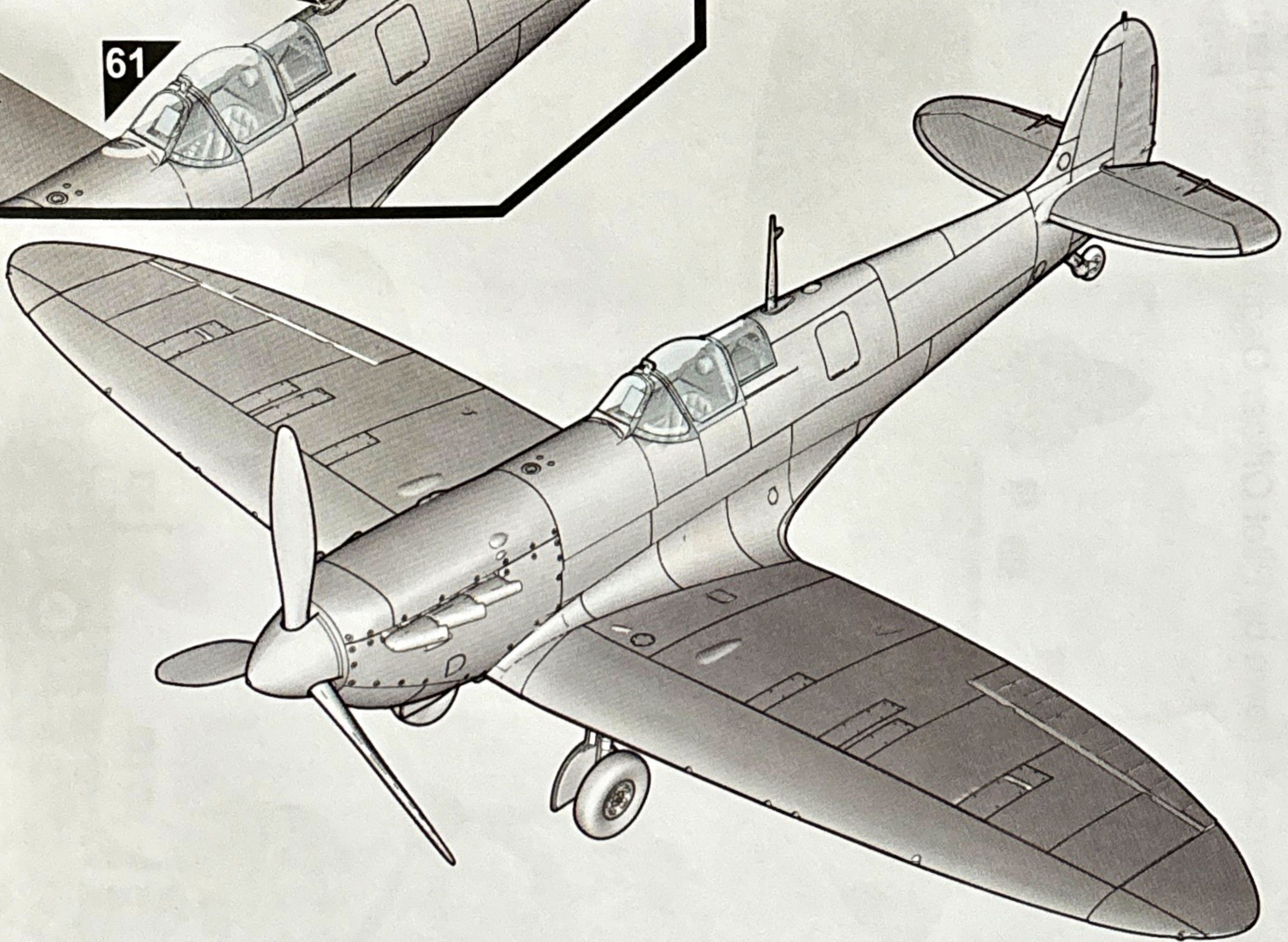
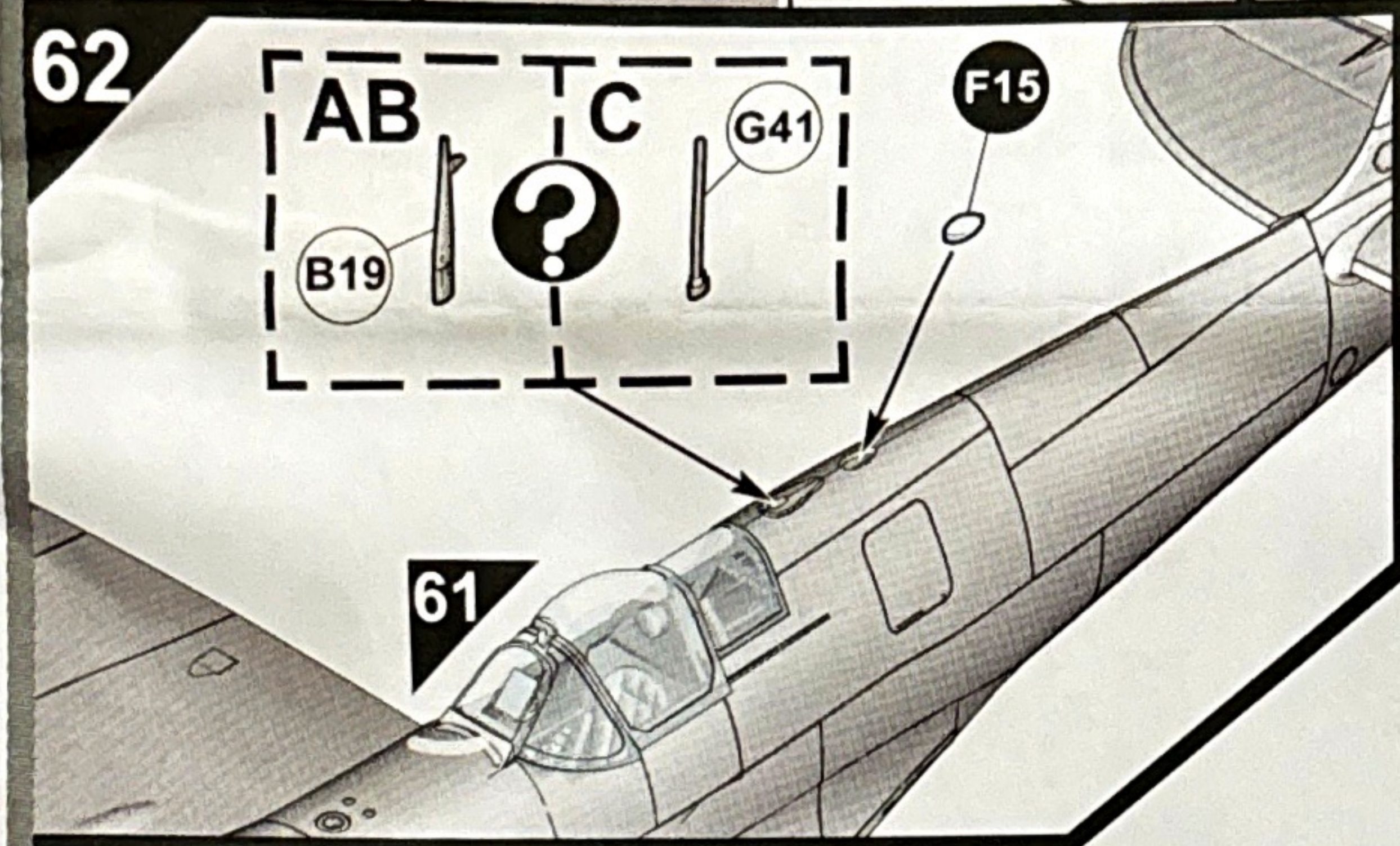
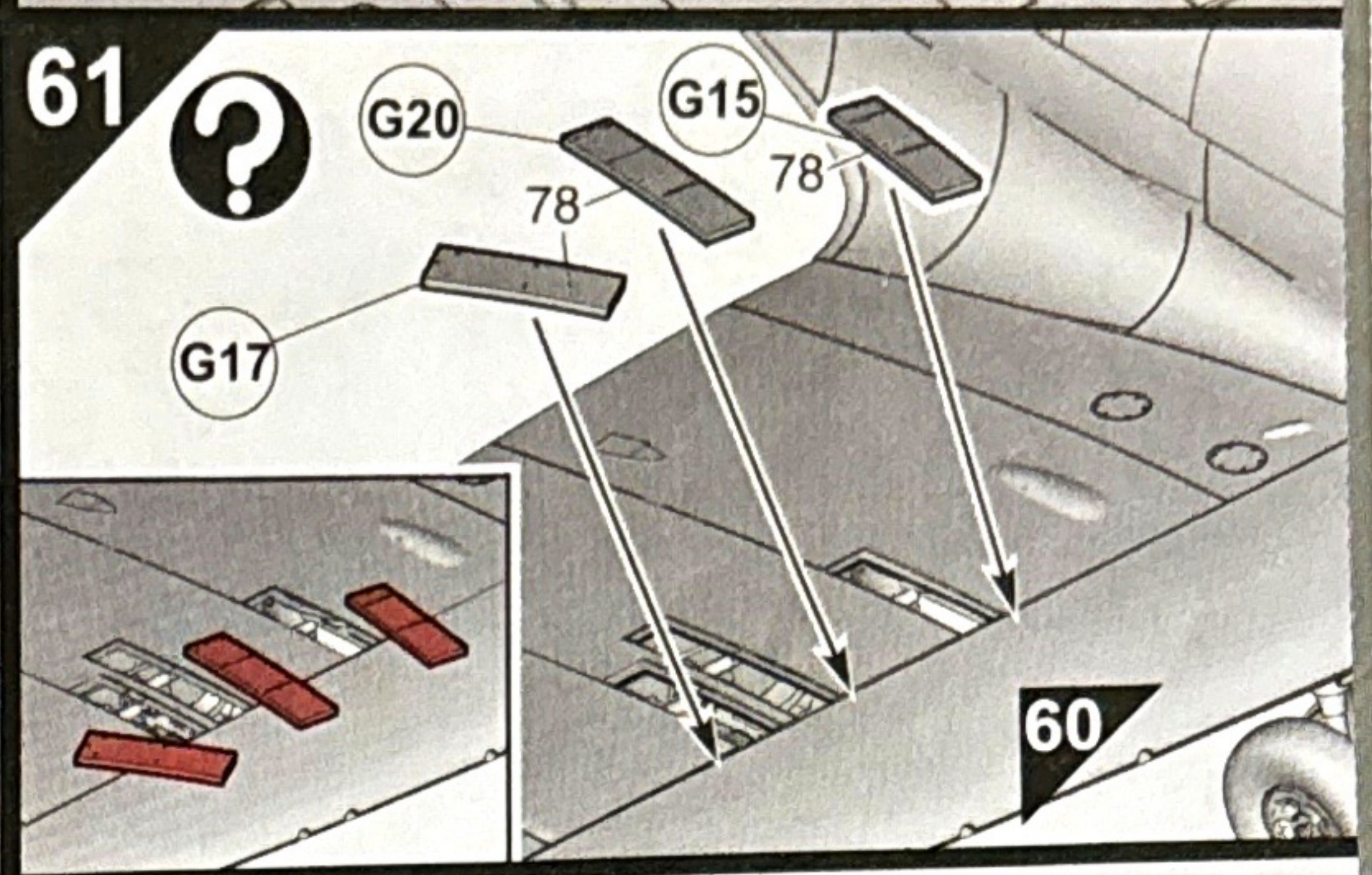
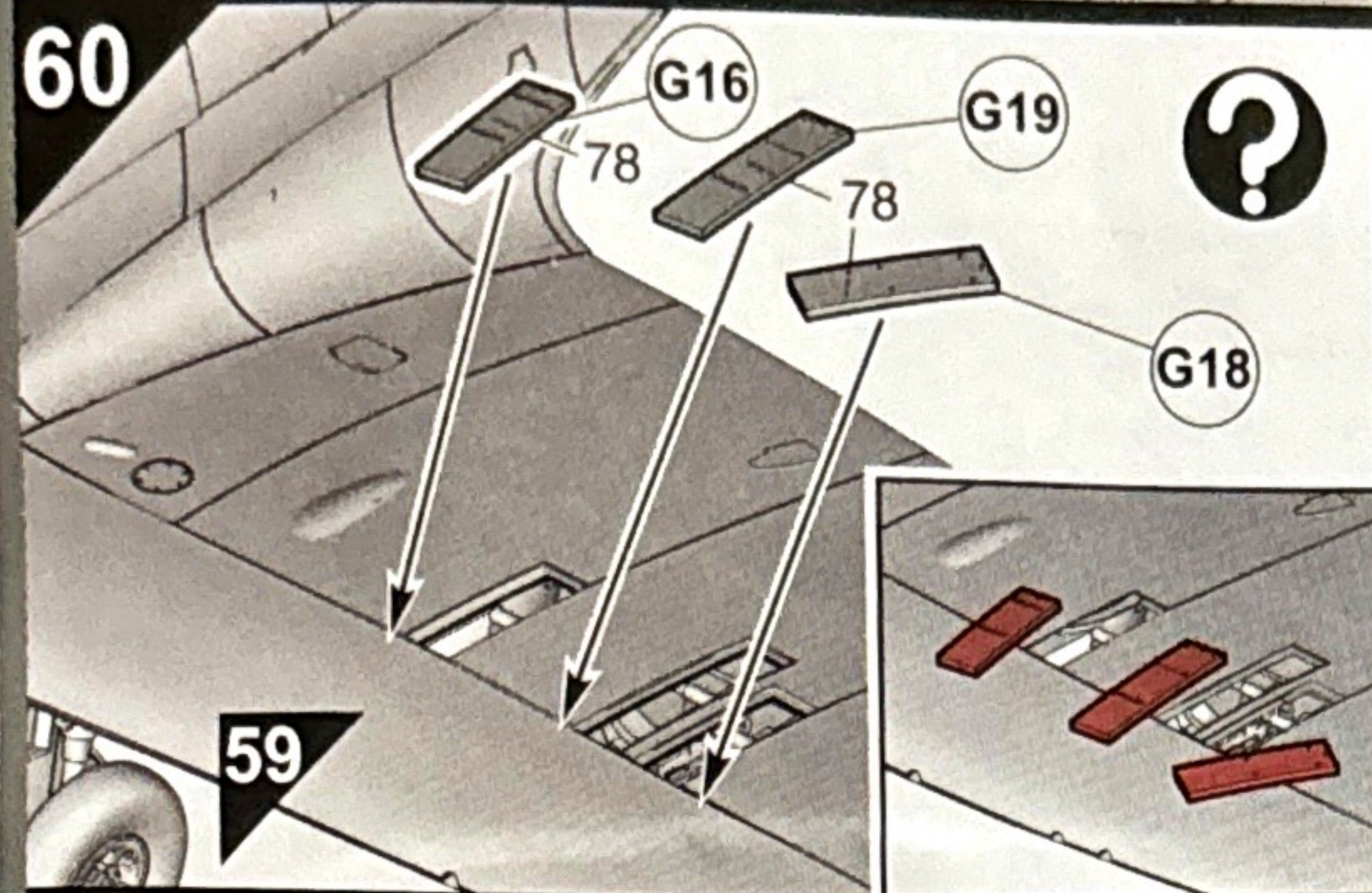
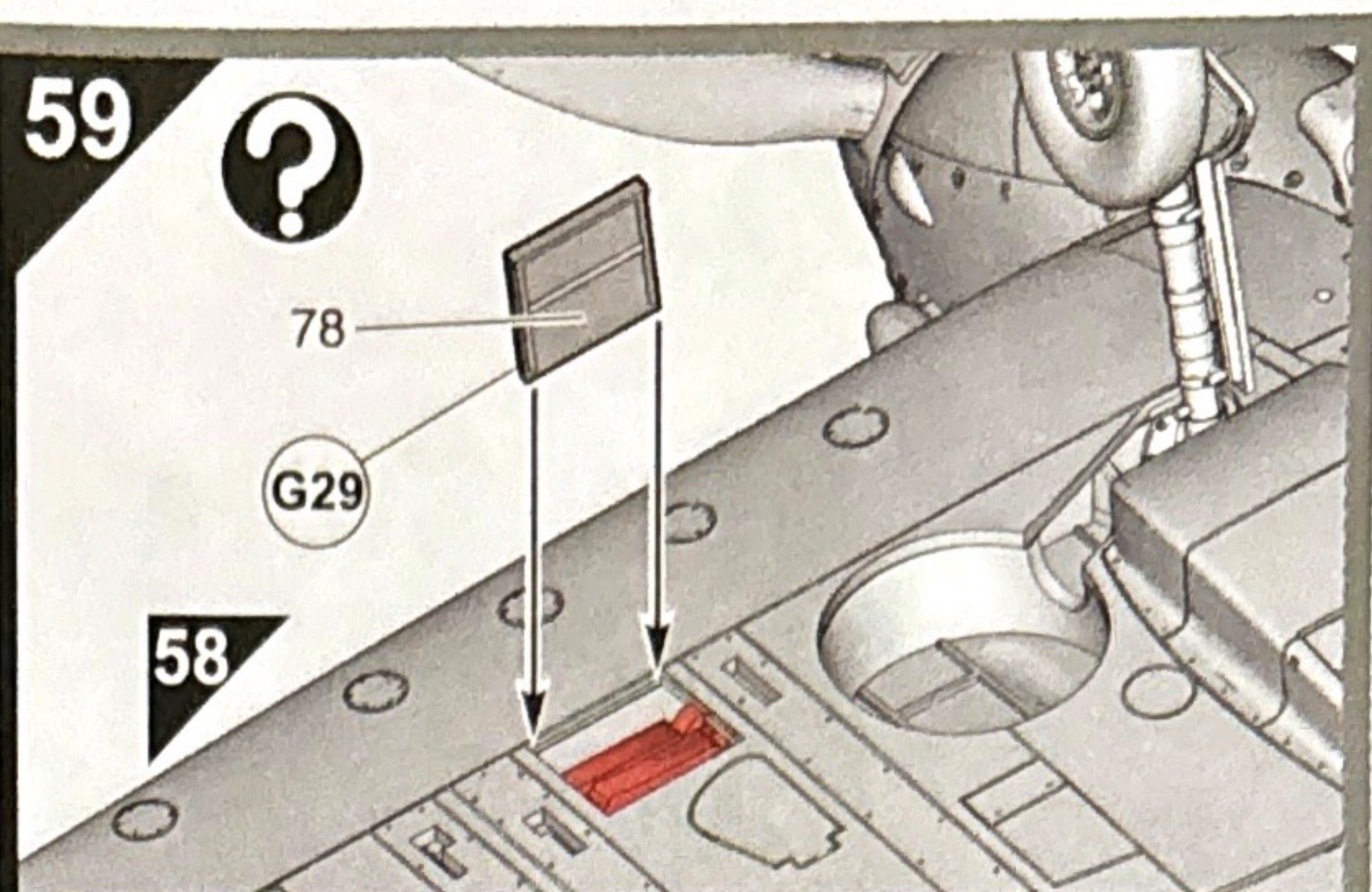
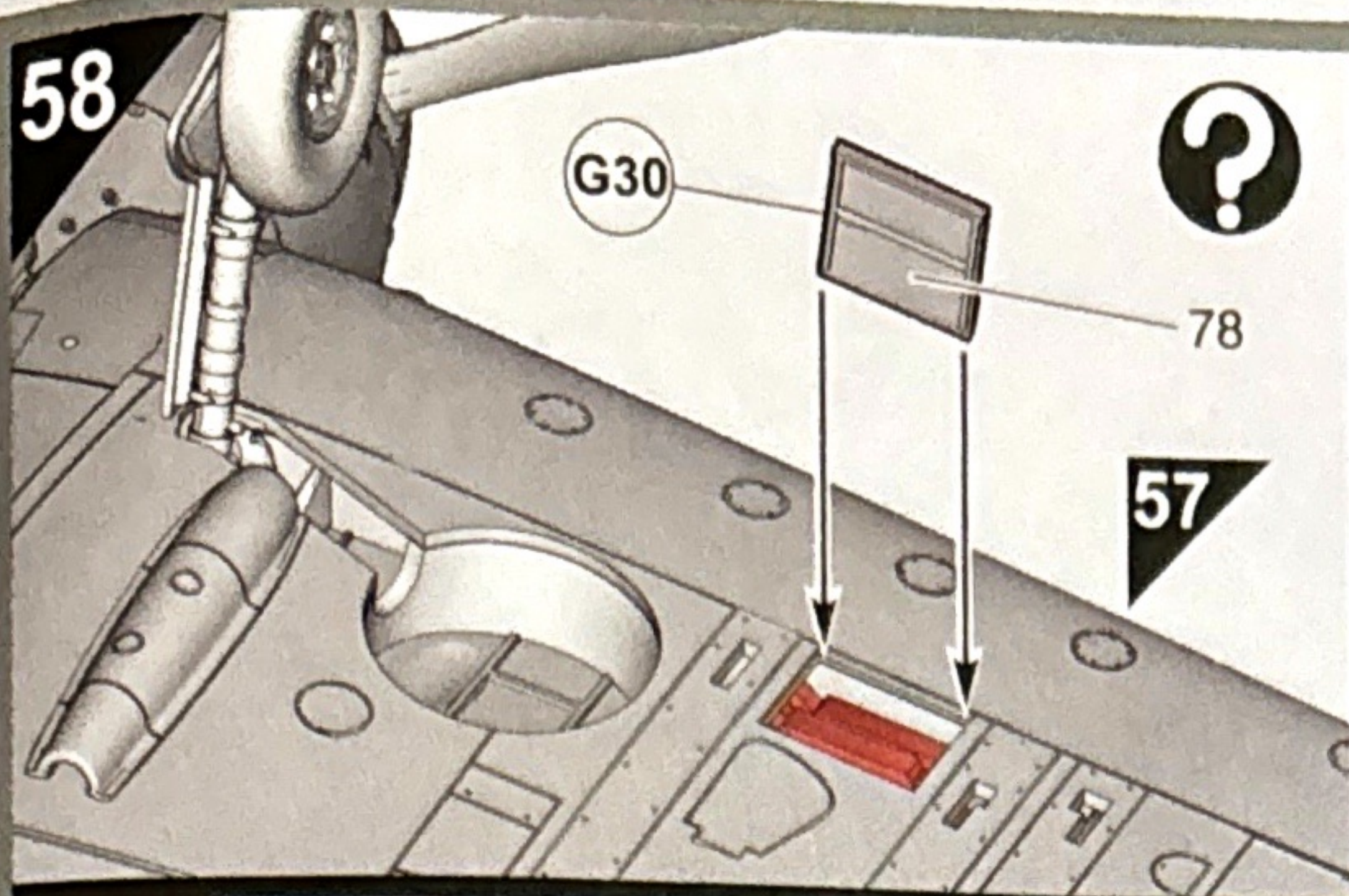

A Supermarine Spitfire Mk.I

Aircraft flown by Pilot Officer Osgood Villiers Hanbury, No. 602 Squadron, Royal Air Force Westhampnett, Sussex, England, August 1940.

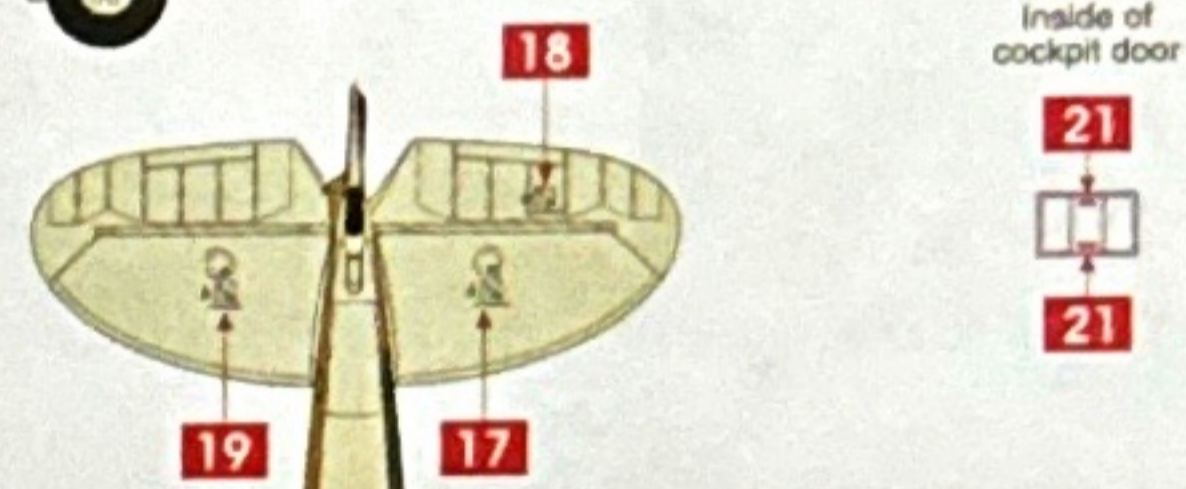
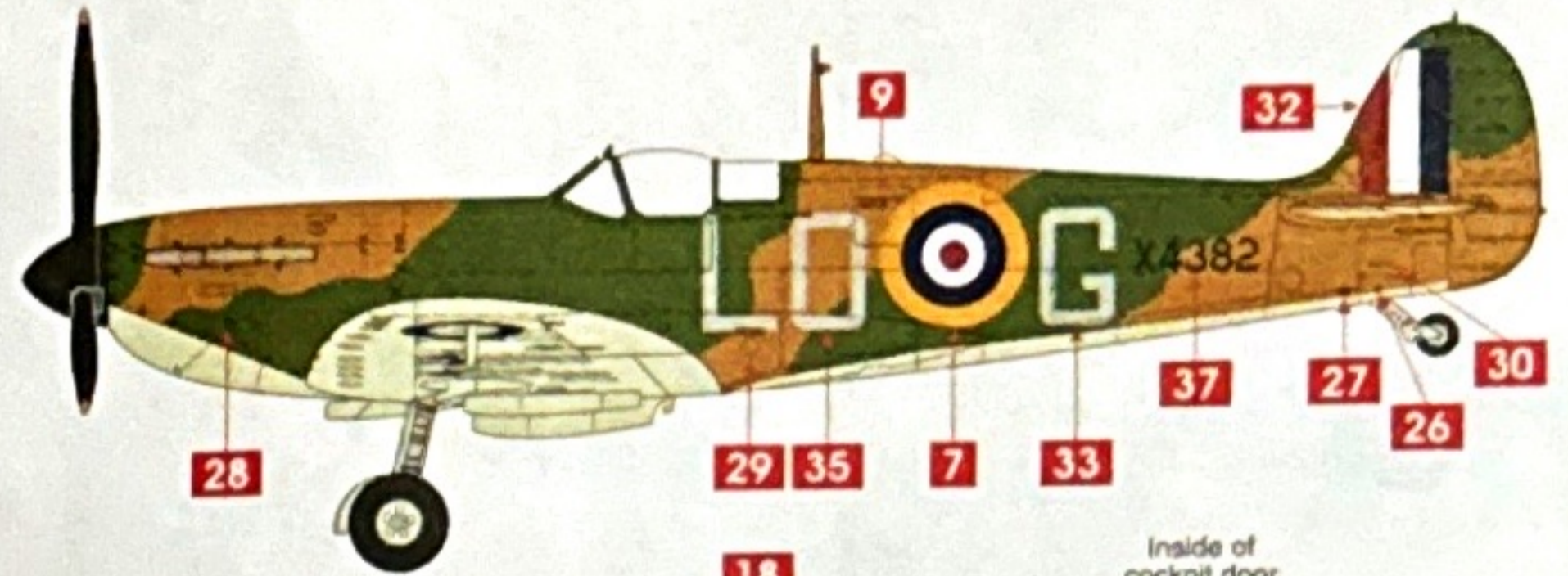
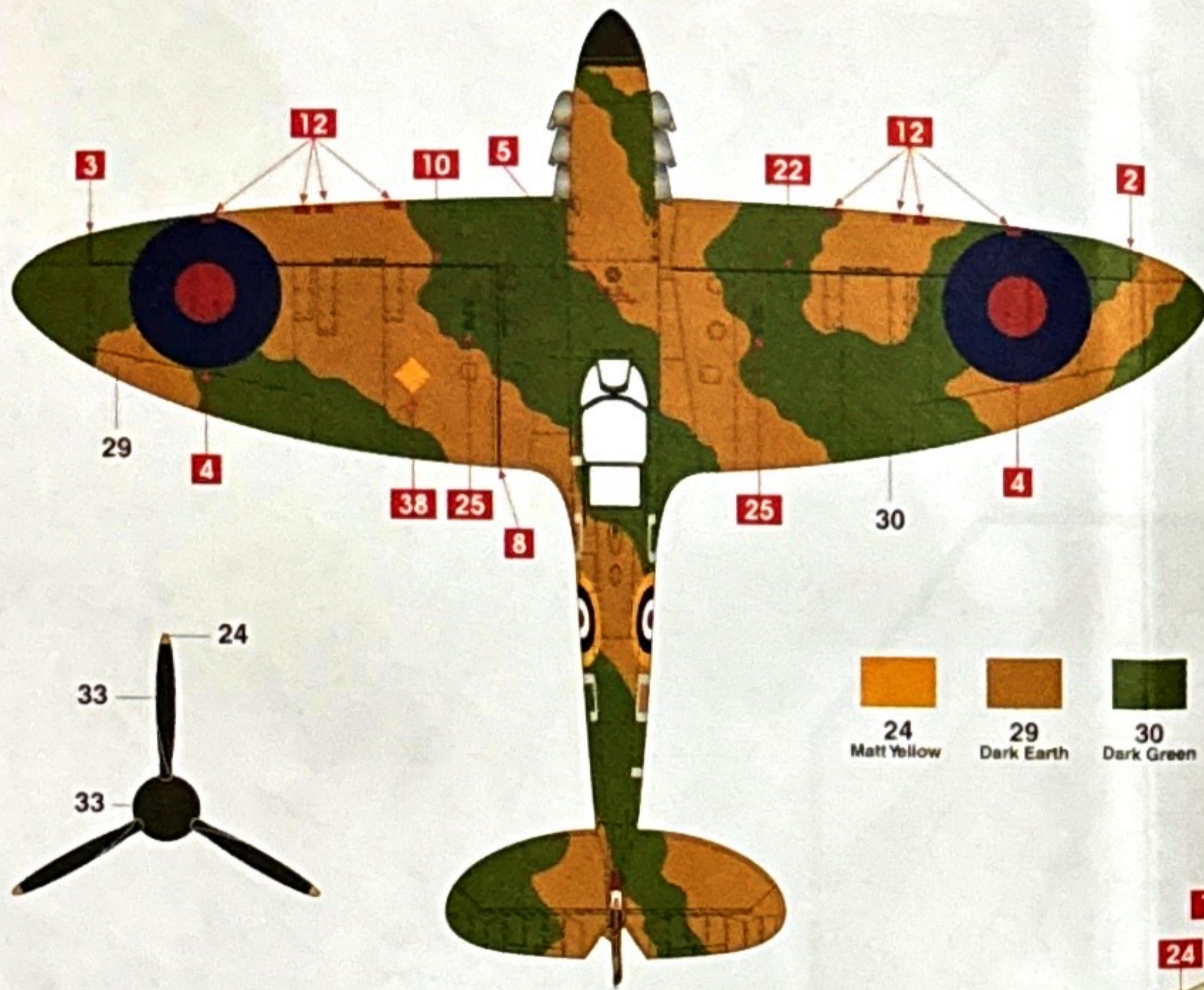

Inside of cockpit door

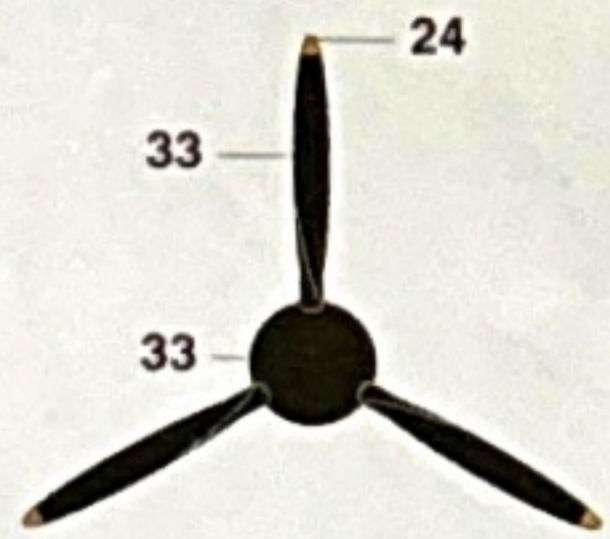

- 
 24
 Matt Yellow
- 
 29
 Dark Earth
- 
 30
 Dark Green
- 
 33
 Matt Black
- 
 90
 Beige Green
 (approx. Sky)

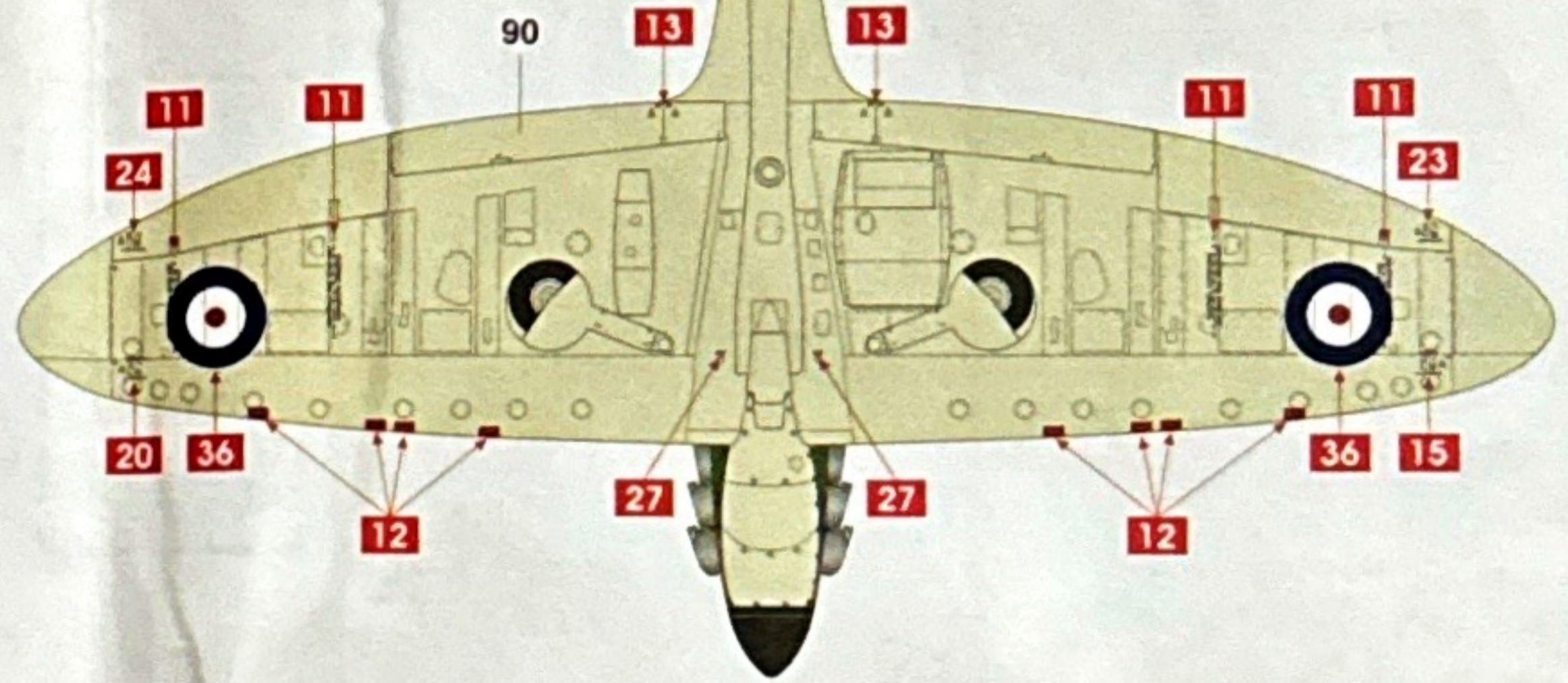

B Supermarine Spitfire Mk.I

No.57 Operational Training Unit, Royal Air Force Hawarden, Flintshire, Wales, mid-1941.

Note: Spitfire AR212 was recorded by its pilot, Flying Officer James Storrar, as having a yellow painted nose. The exact shade and configuration is unknown but appears paler than yellow in the roundel in photographs of the aircraft.

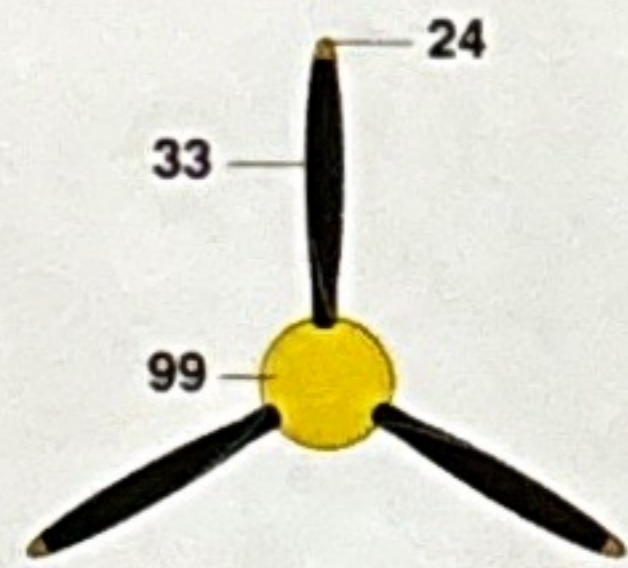
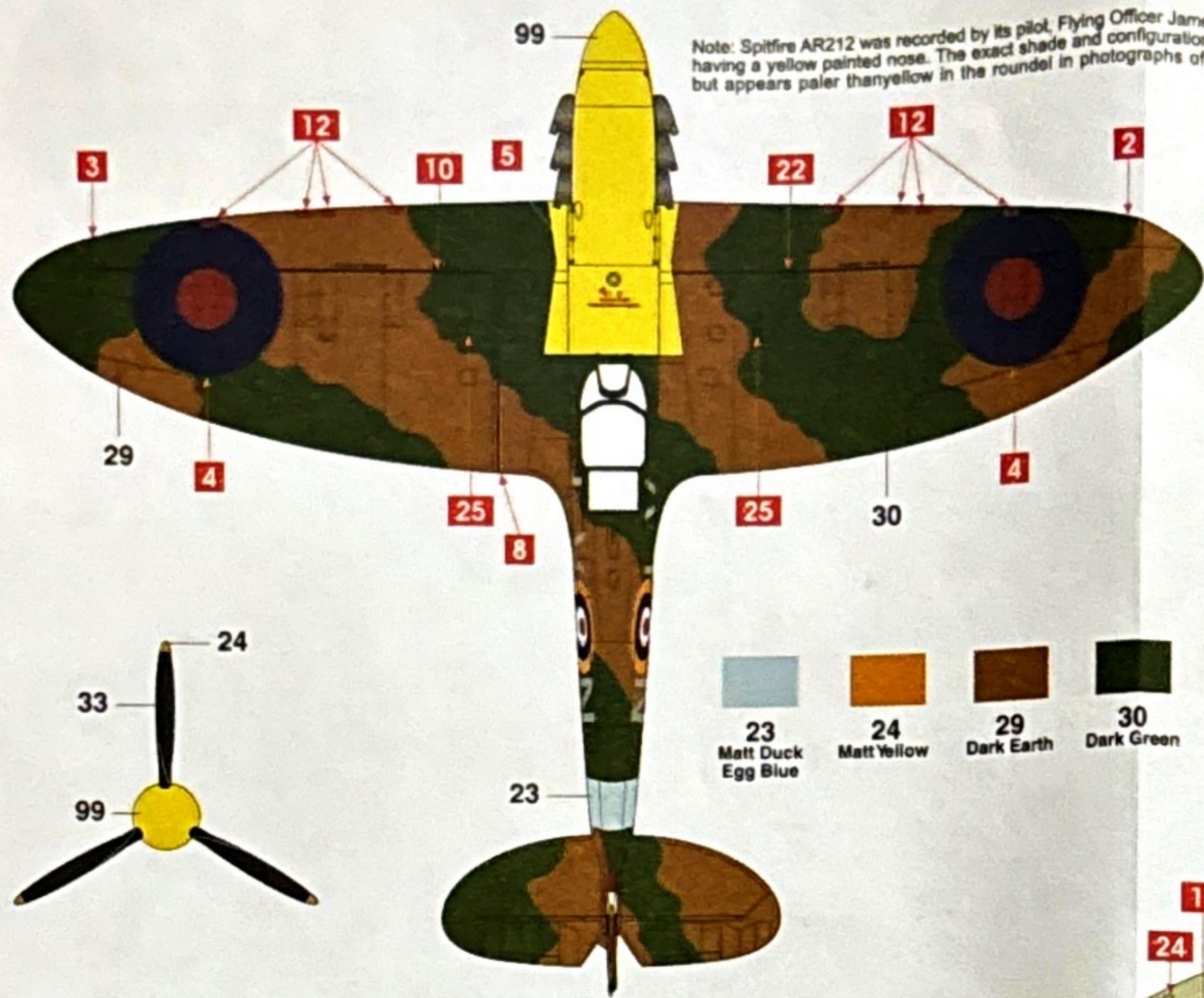

- | | | | | | | |
|-----------------------------|-------------------|------------------|------------------|------------------|------------------------------------|------------------|
| | | | | | | |
| 23
Matt Duck
Egg Blue | 24
Matt Yellow | 29
Dark Earth | 30
Dark Green | 33
Matt Black | 90
Beige Green
(approx. Sky) | 99
Matt Lemon |

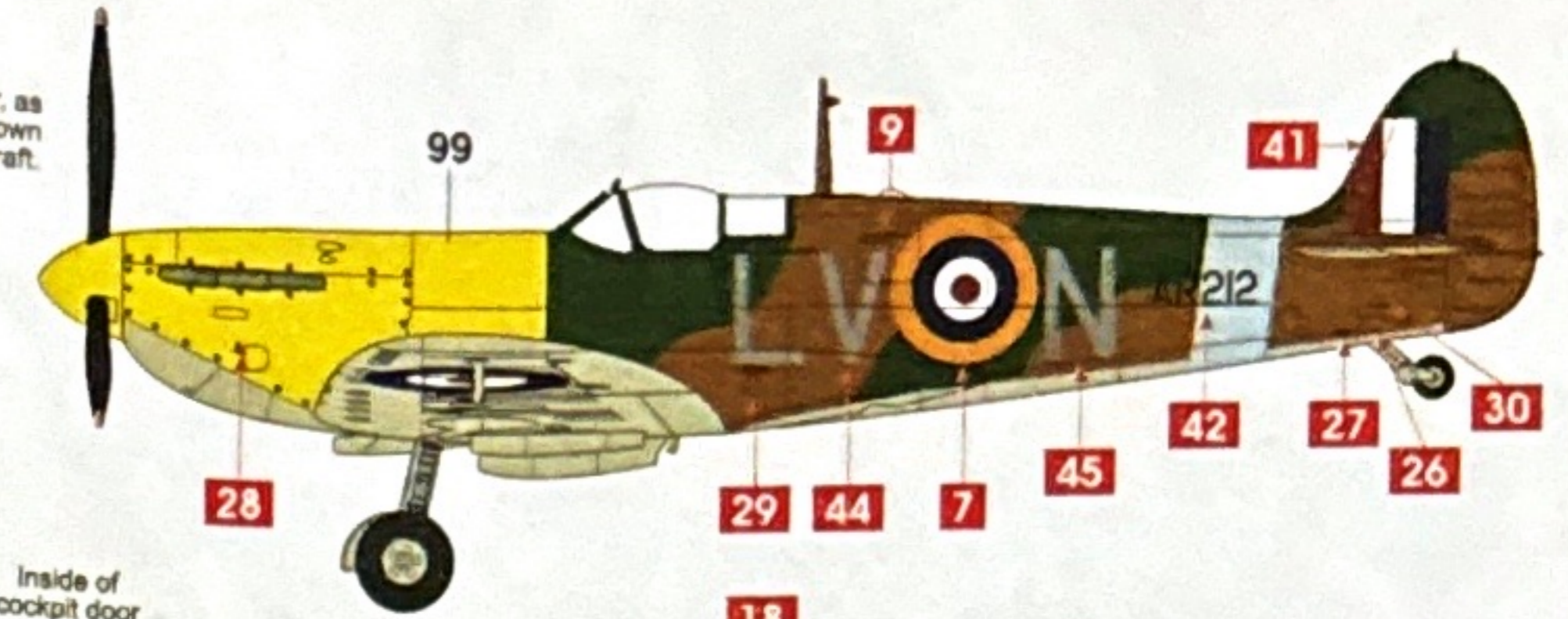

Note: Possible alternative configuration.

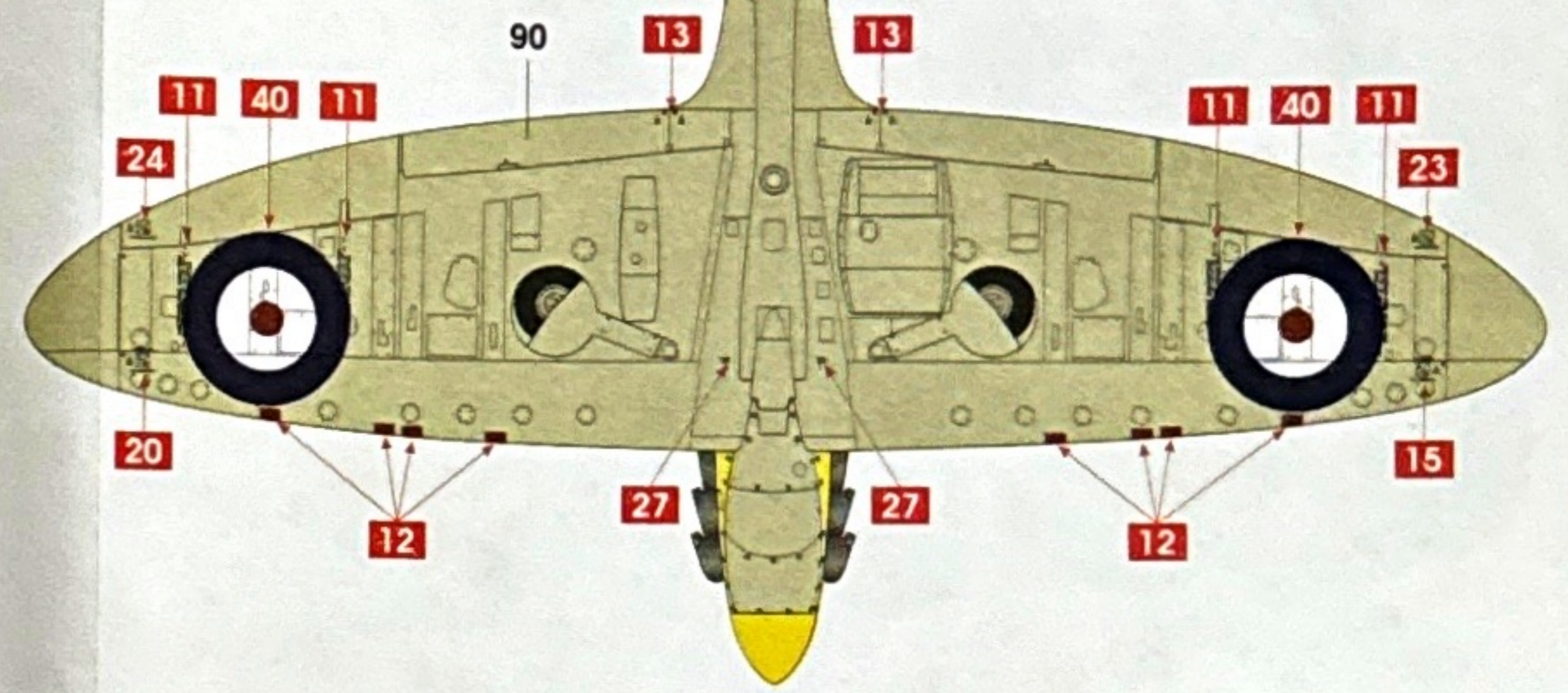
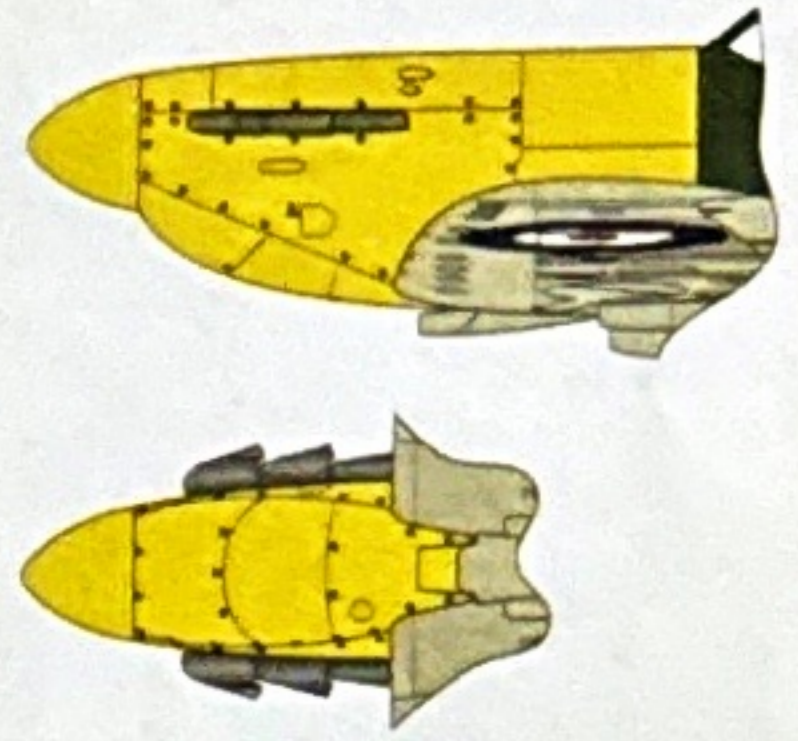

© Supermarine Spitfire Mk.I
 No.19(F) Squadron, Royal Air Force Duxford, UK, August 1938.

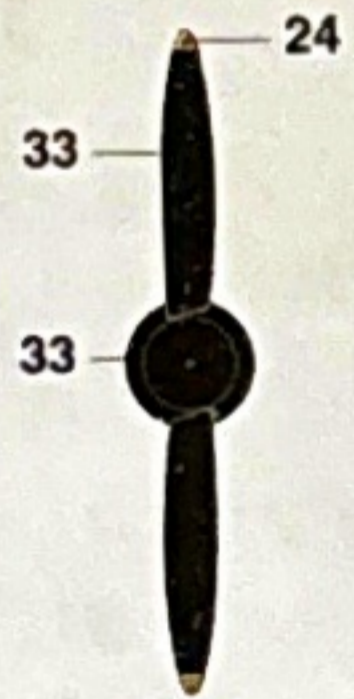
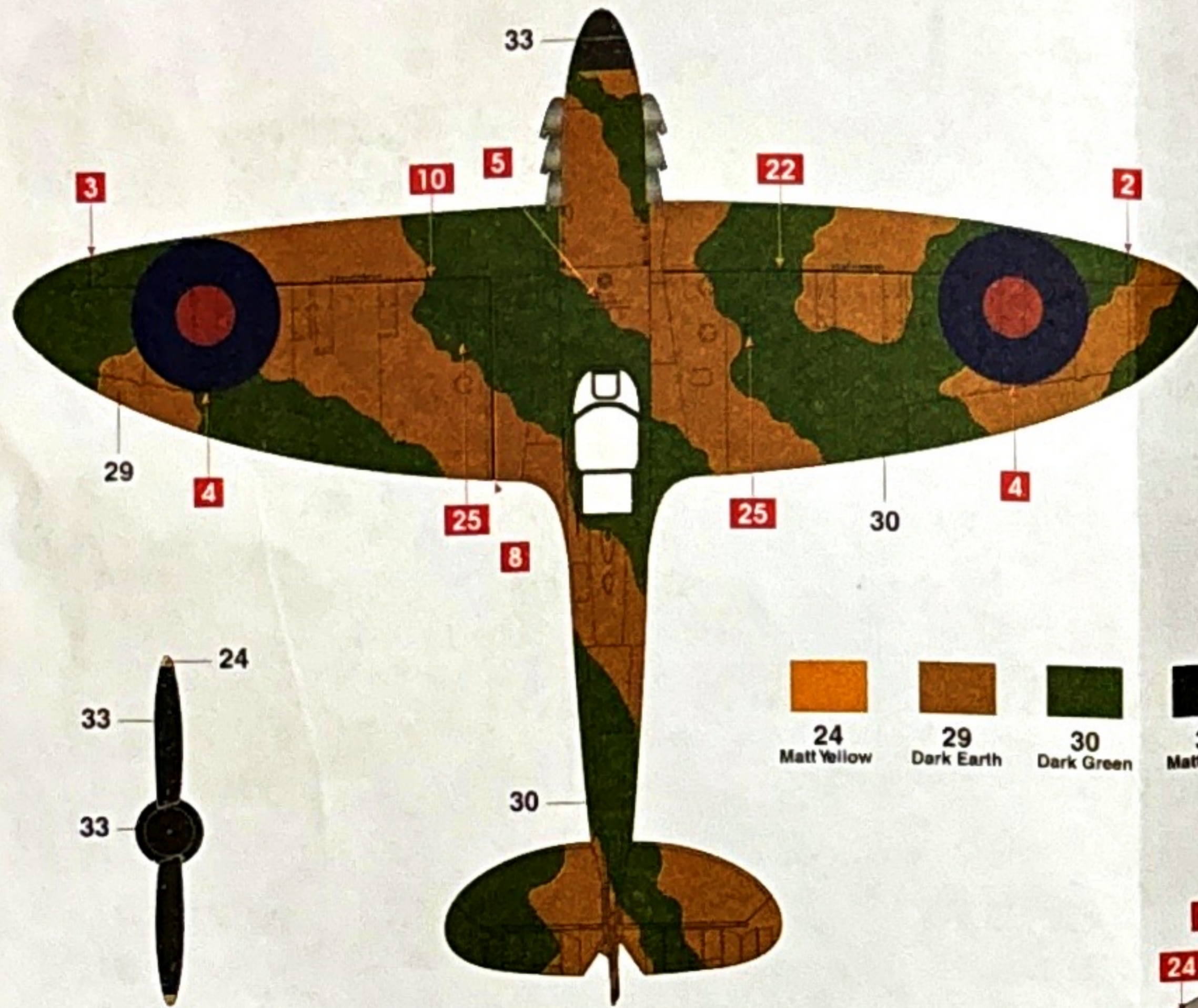

24	29	30	33	34	56
Matt Yellow	Dark Earth	Dark Green	Matt Black	Matt White	Aluminium

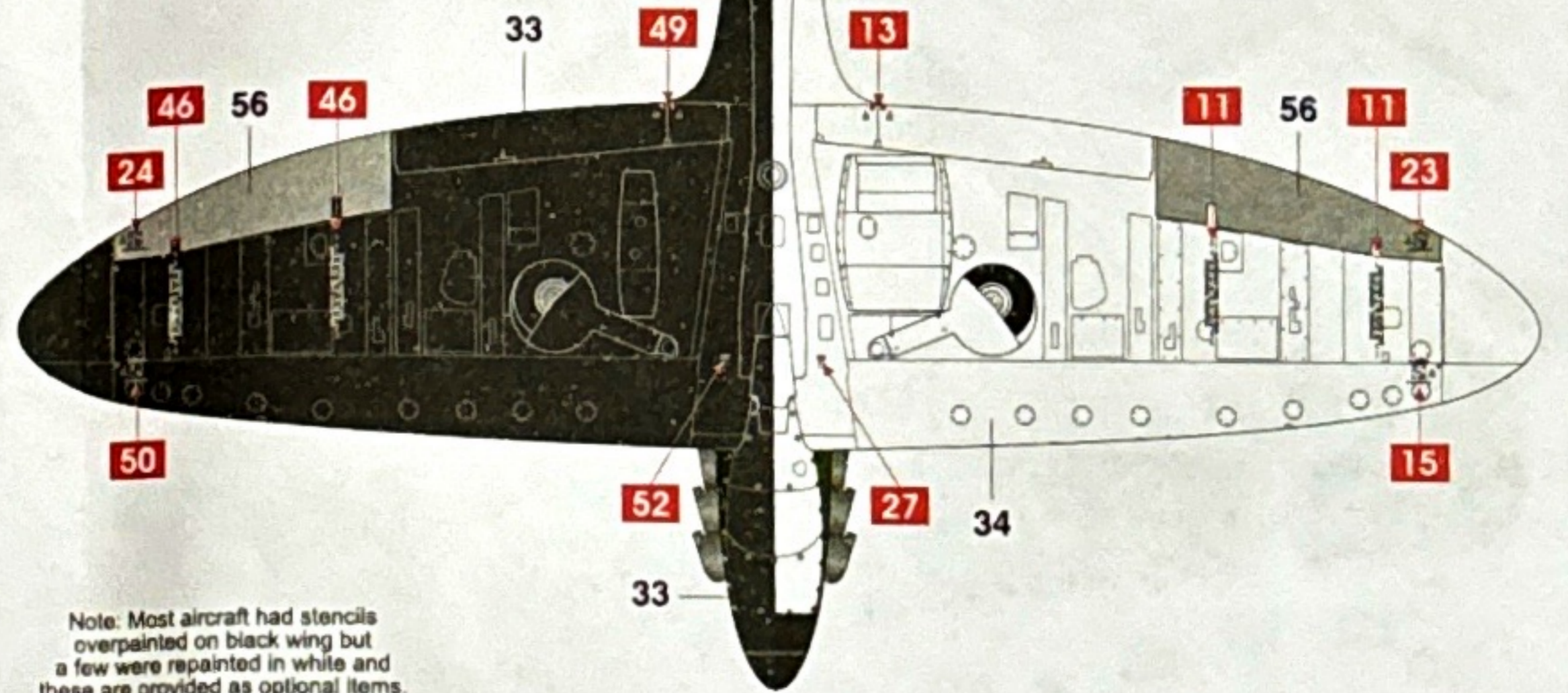

Note: Most aircraft had stencils overpainted on black wing but a few were repainted in white and these are provided as optional items.