

Russian MIG-29SMT Fulcrum

俄罗斯米格-29SMT“支点”战斗机

READ BEFORE ASSEMBLY:

- This kit is not recommended for inexperienced modelers or for children under 14 years of age
- Study and understand these instructions thoroughly before beginning assembly
- When needed, remove photo-etch parts carefully using a modeling knife or photo etch sprue cutter, being careful not to damage or lose small parts.
- Take extra care in handling photo etch parts in order to avoid injury
- Apply instant cement sparingly to photo etch parts where instructed

- Tools recommended(not included in kit):Plastic and instant cements,sprue cutters,long nose pliers,modeling knife, small files, tweezers, pin vise & scissors. Soft cloth and sandpaper will also assist in construction
- Glue and paint are not included in the kit. Use plastic cement and hobby paints only. Color guide for purchasing paint is included in the kit.
- Keep out of reach of children. They must not be allowed to ingest small parts or handle plastic bags in any way.

装配之前仔细阅读

- 小心用模型锉刀锉平所有零件表面的注射浇口。
- 小心用刀片切下蚀刻片零件，不要遗失小零件。
- 用强力快干胶水粘合蚀刻片零件和金属轴。过量的快干胶水使用可能导致可动零件会粘住，小心涂胶。
- 取蚀刻片时应特别注意安全，防止利边划伤手指。
- 某些零件表面需贴上水贴纸，请选择在装配的同时进行。
- 推荐模型工具(自备)：胶水，水口剪刀，长咀钳，刀片，锉刀，镊子钳，钻，剪刀，瞬间快干胶。
- 软布同砂纸同时也应该是必备工具。
- 请使用塑料胶水和油漆，模型内不含。
- 谨防小孩吸吮塑料零件，或者将塑料袋套在头上，制作时应将套材远离小孩接触。
- 本产品不适合14岁以下没有经验的模型爱好者。

水贴纸的使用:

1. 从水贴纸上剪下印花;
2. 将印花放入温水中浸10秒，然后放在干净布上。
3. 拿着印花纸板将印花移到模型上;
4. 手指蘸水将印花移到适当的位置;
5. 用软布轻压印花直至水干，气泡消失。

DECAL APPLICATION:

1. Cut decals from sheet as needed
2. Dip the decal in warm water for about 10 seconds and then place on soft clean cloth.
3. Hold the decal backing sheet edge and gently slide the decal onto the model in its proper position.

4. While still wet,decal can be adjusted for better fit on model by dampening it gently with your finger.
5. When placed in the proper position,gently press decal down with a soft cloth until excess water and air bubbles are gone.
6. Allow decal to dry completely before handling model



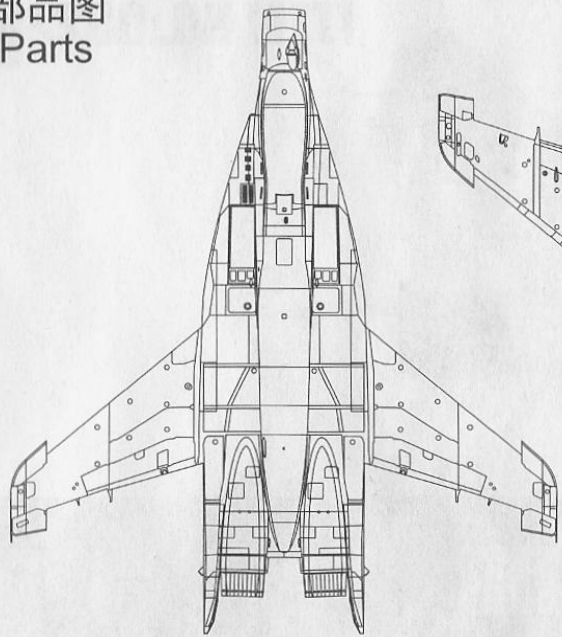

《上部机身》
Top fuselage

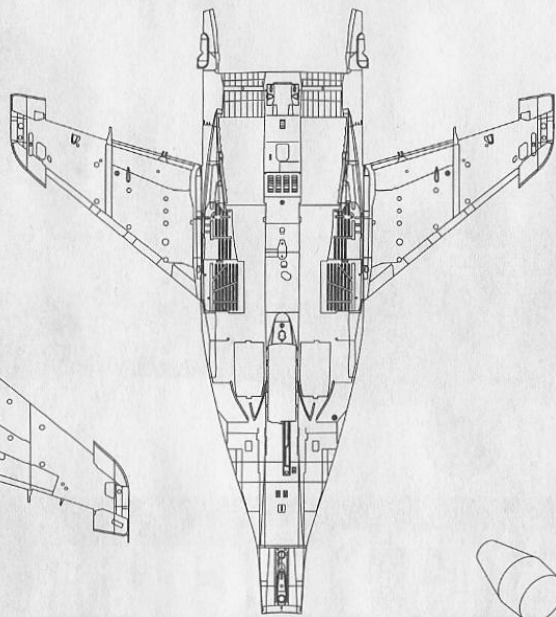

《下部机身》
Lower fuselage



《配重》
Weight

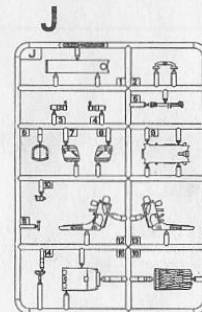
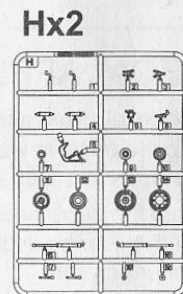
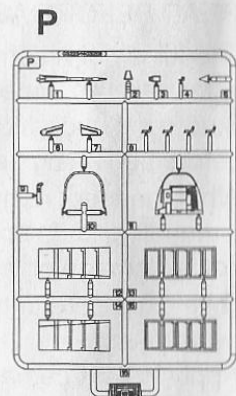
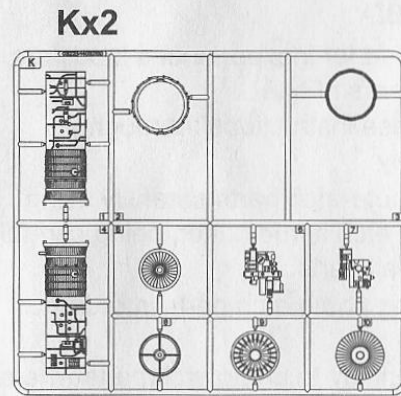
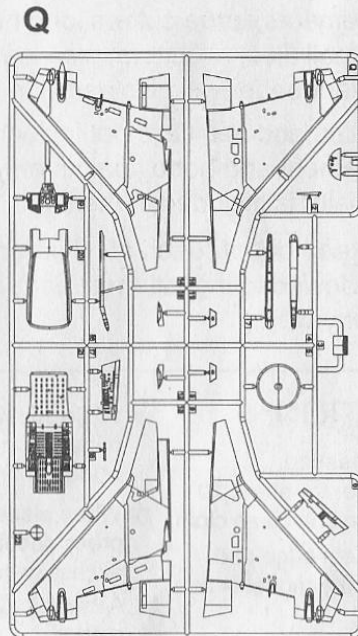
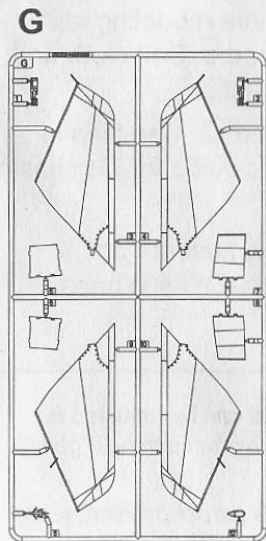
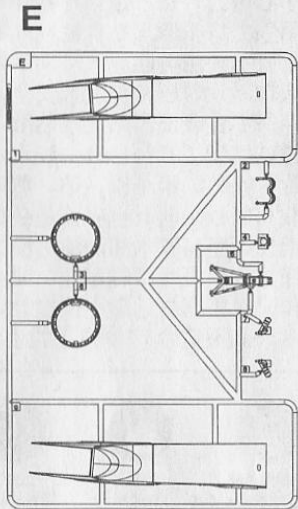
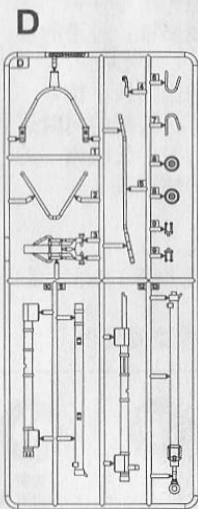
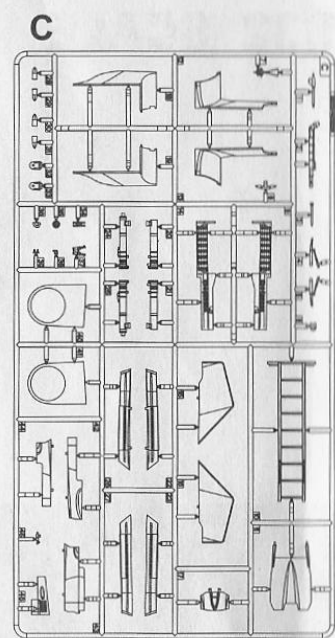
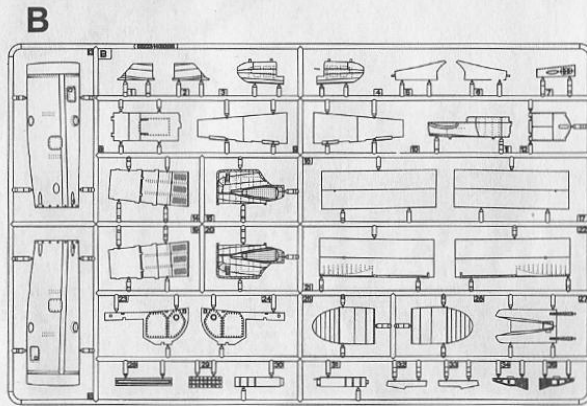
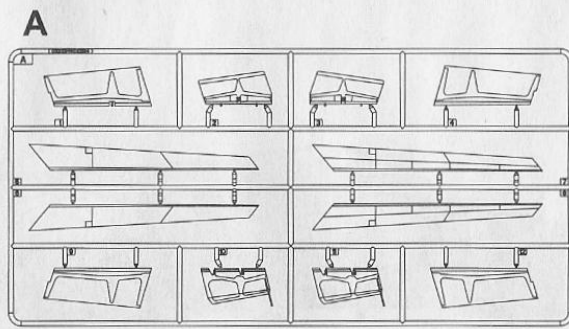

Lx2

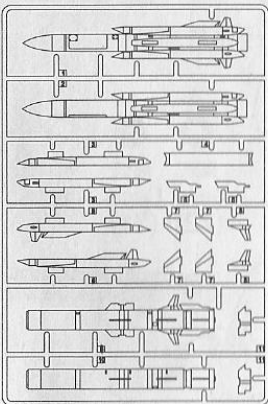

Mx2

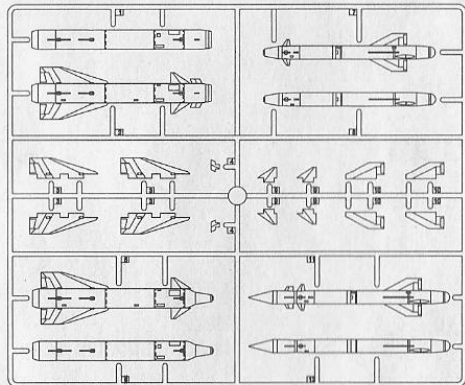

S

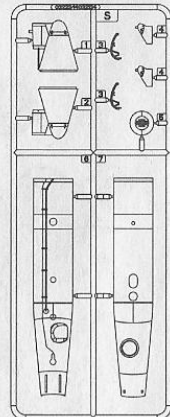

Nx2

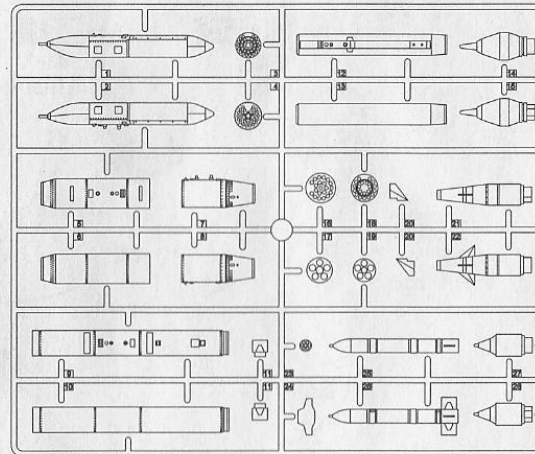

Ux2

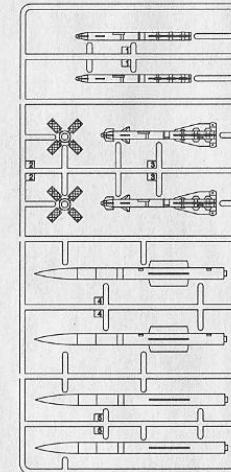

Yx2

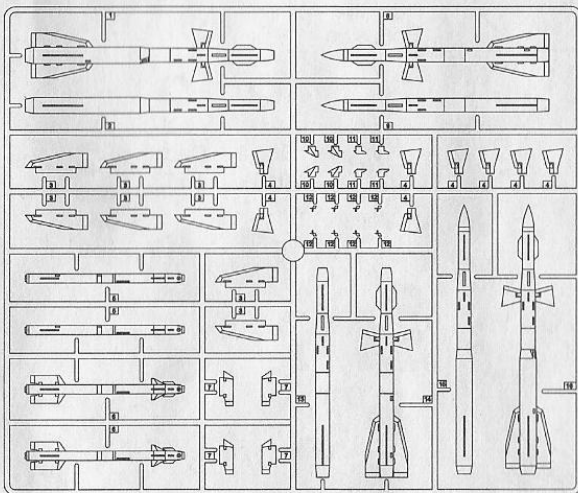

H1x2

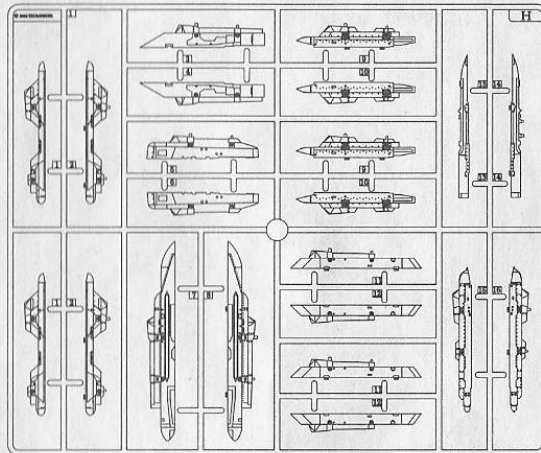

G1x2

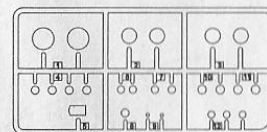

GP1

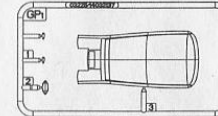

GP2

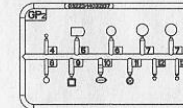

GP6

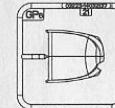

PE-A

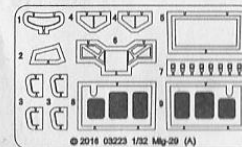

PE-B

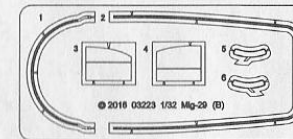

PE-C

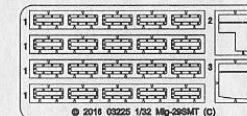

《尾轮胎》
Tail tyre x2

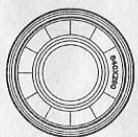

《前轮胎》
Nose tyre x2



《前起落架》
Nose undercarriage

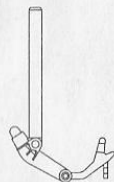

《左侧主起落架》
Left main undercayriage

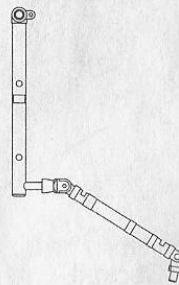

《右侧主起落架》
Right main undercayriage

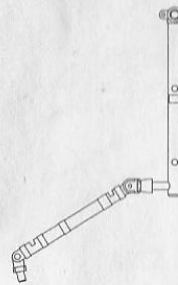

《水贴纸》A
Decal A



《水贴纸》B
Decal B

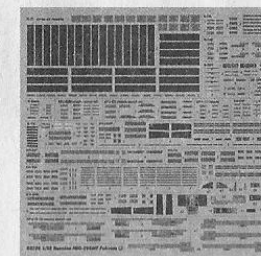

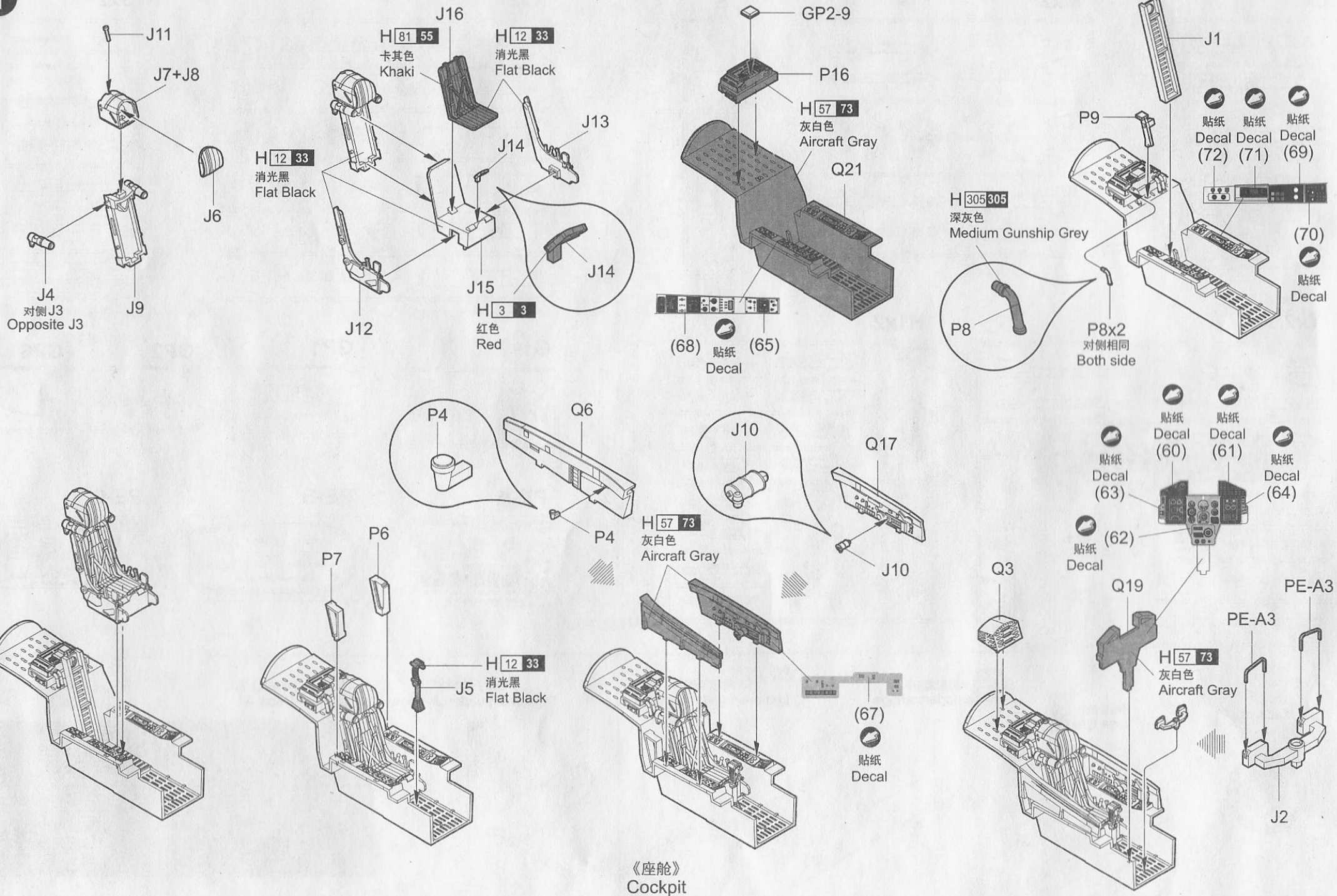

2

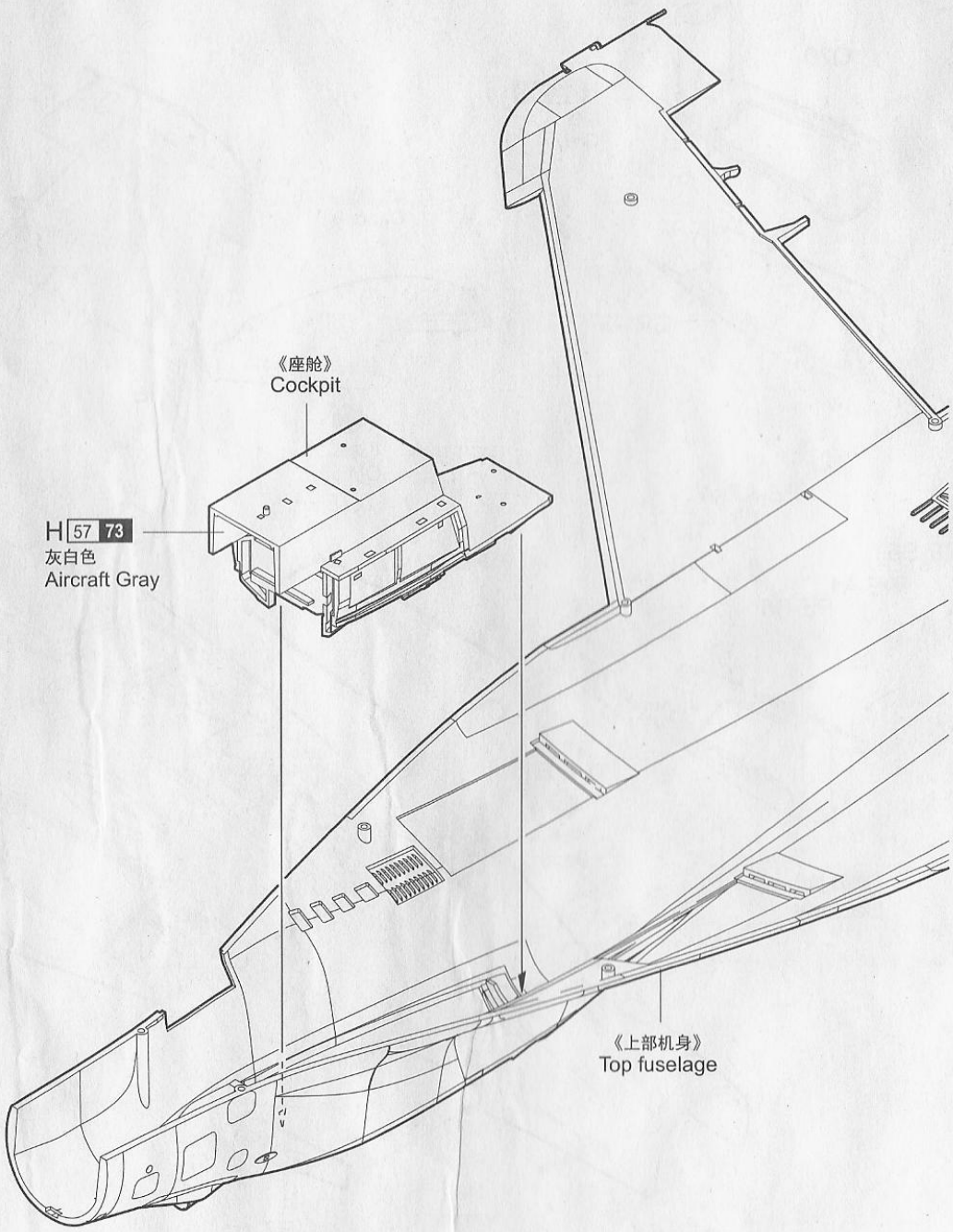

3

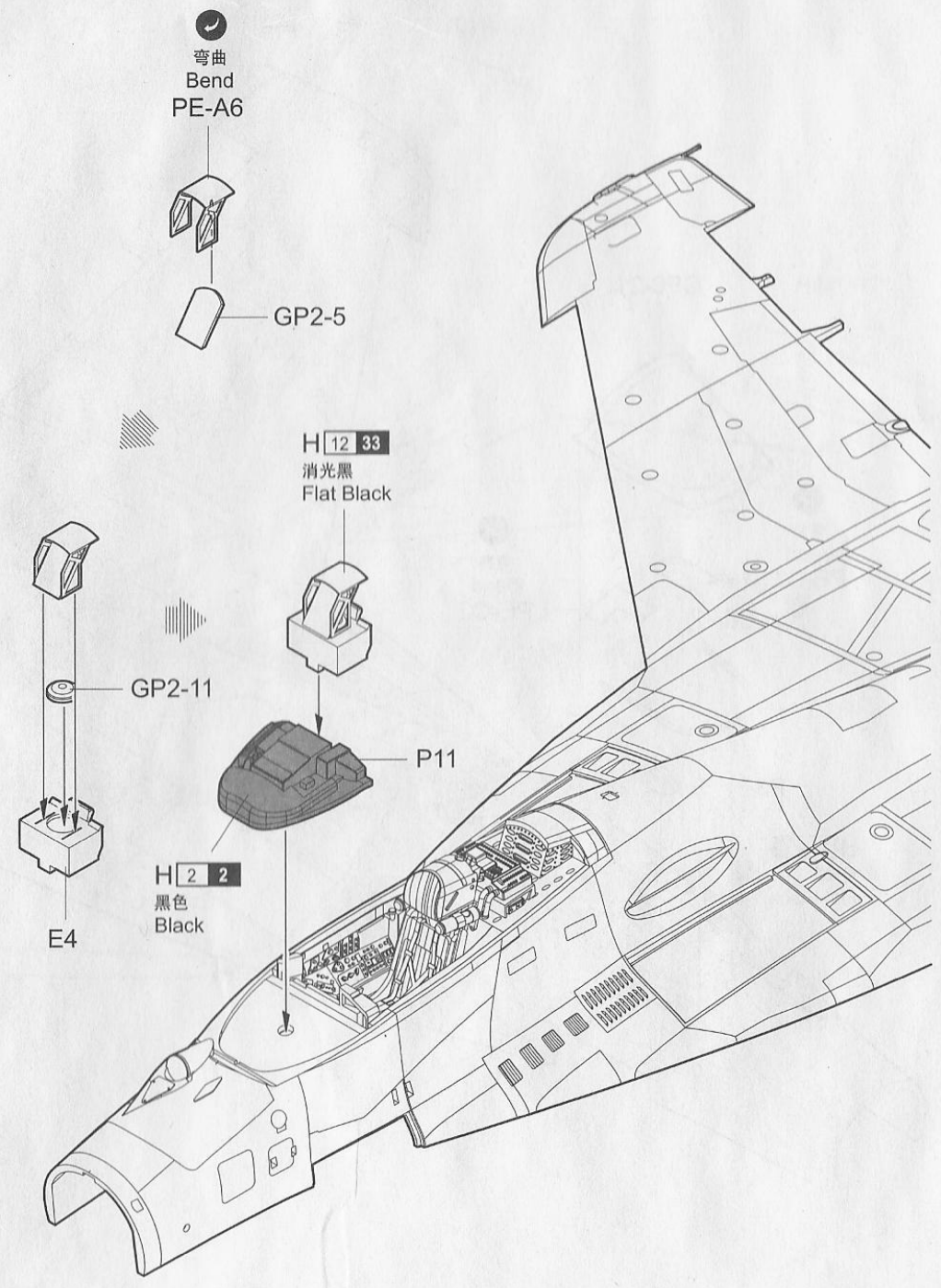

4

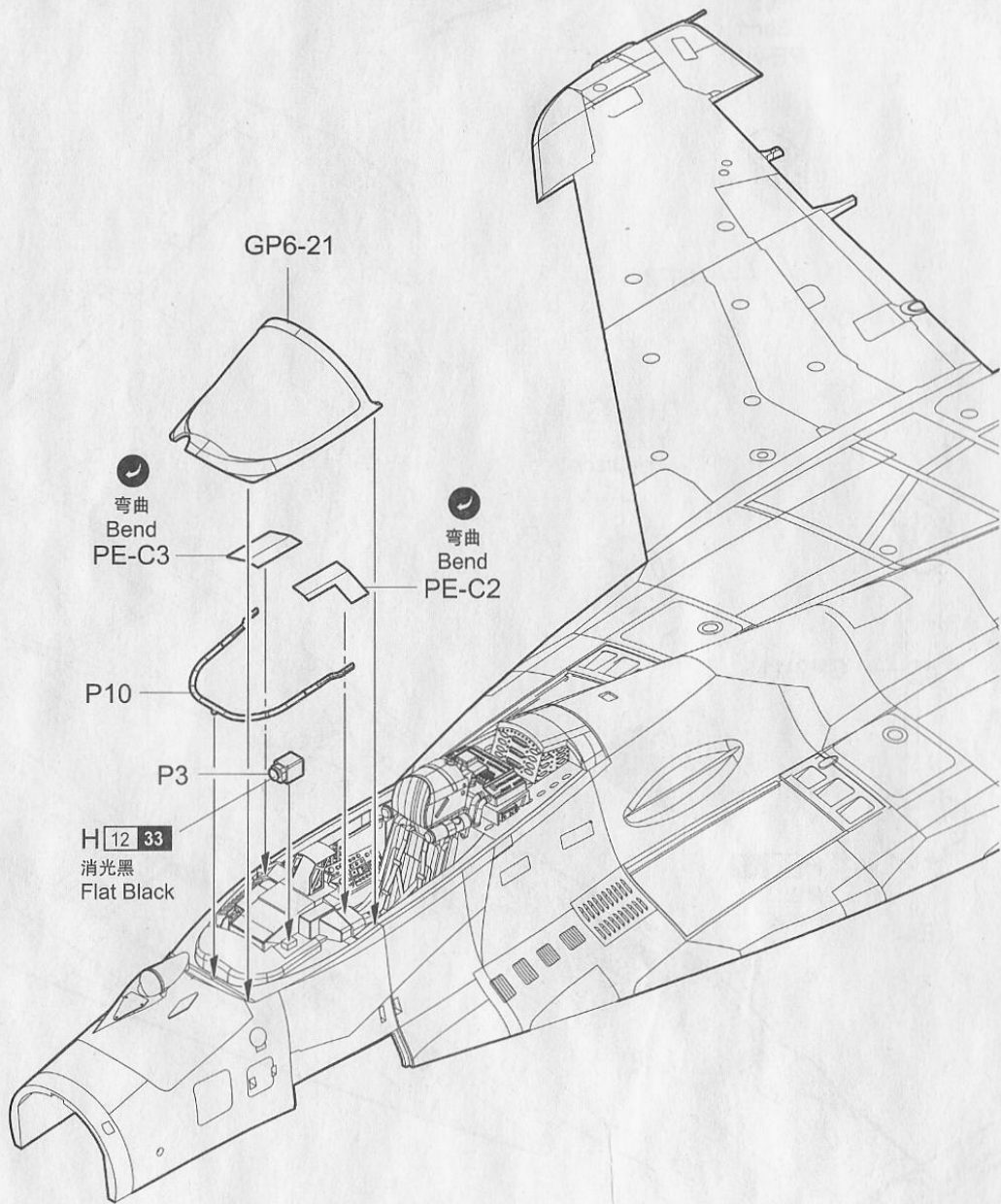

5

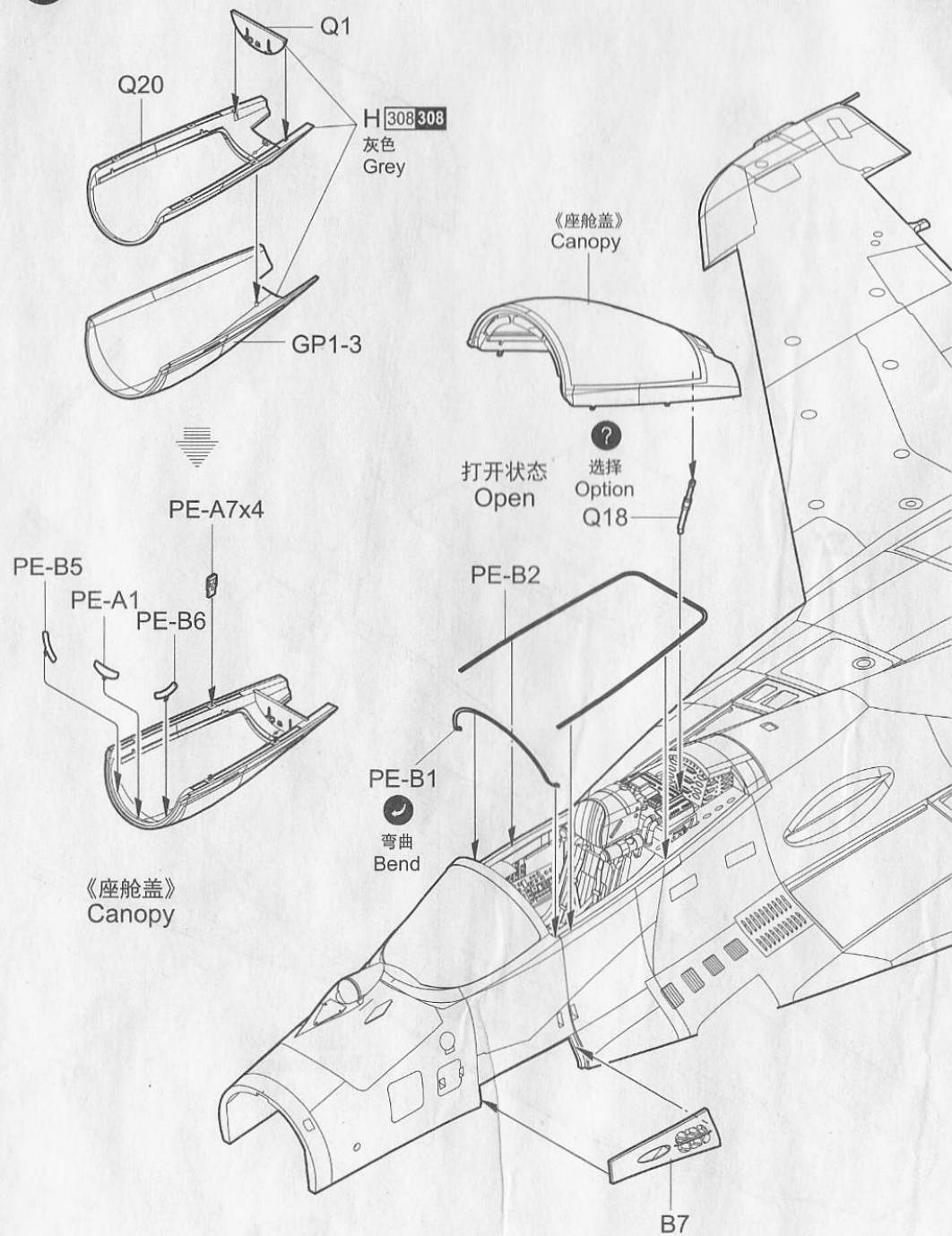

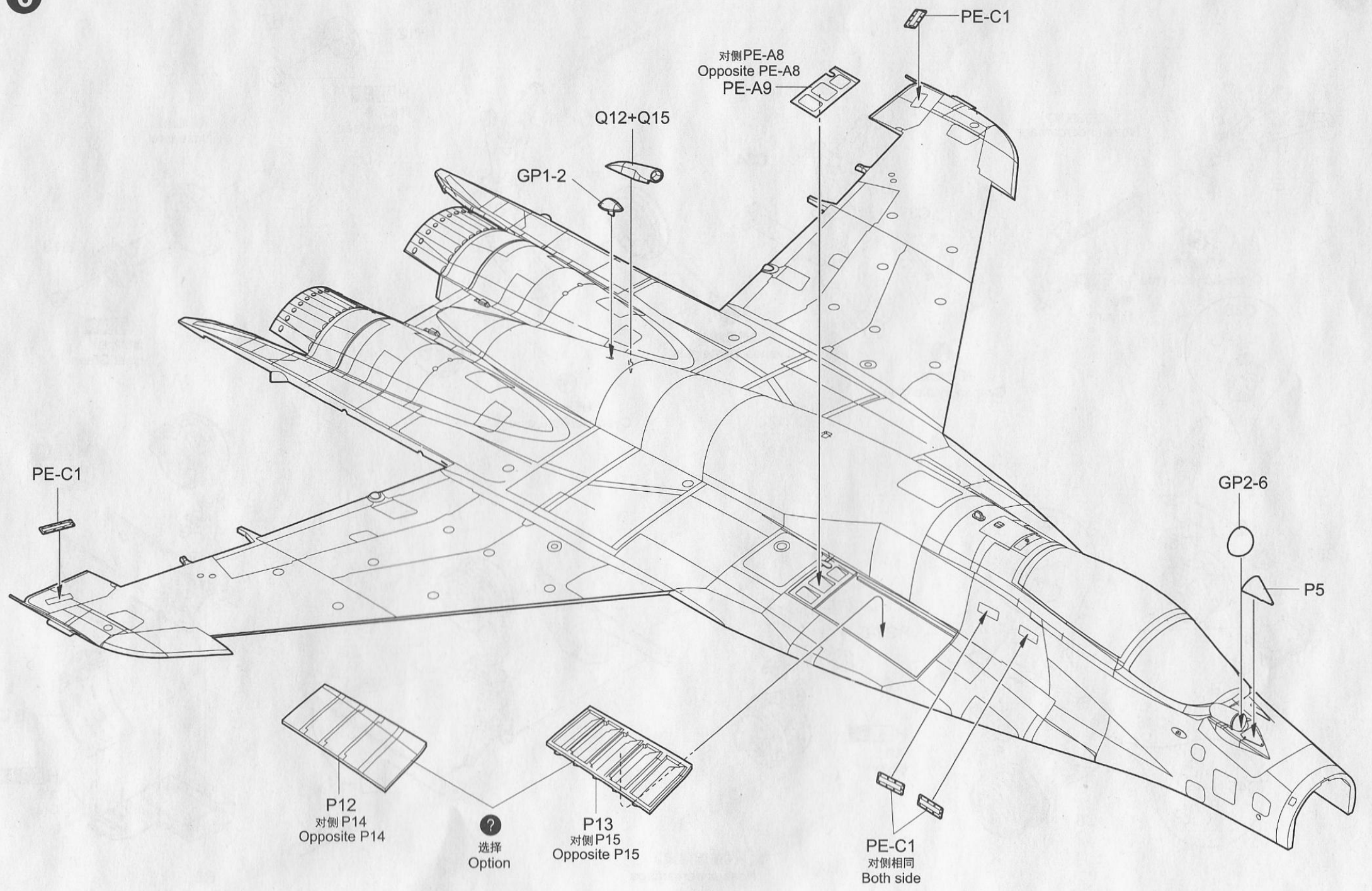

对侧PE-A8
Opposite PE-A8
PE-A9

Q12+Q15

GP1-2

PE-C1

PE-C1

GP2-6

P5

P12
对侧P14
Opposite P14

选择
Option

P13
对侧P15
Opposite P15

PE-C1
对侧相同
Both side

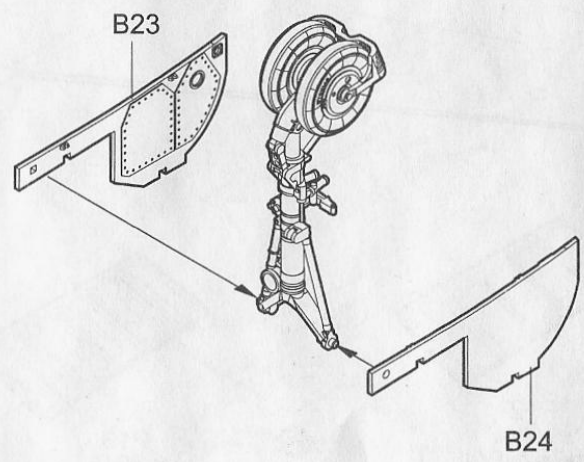
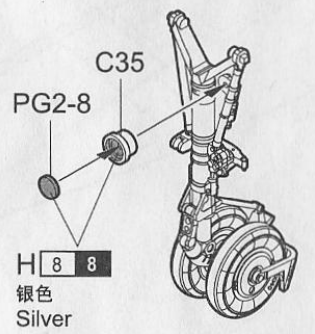
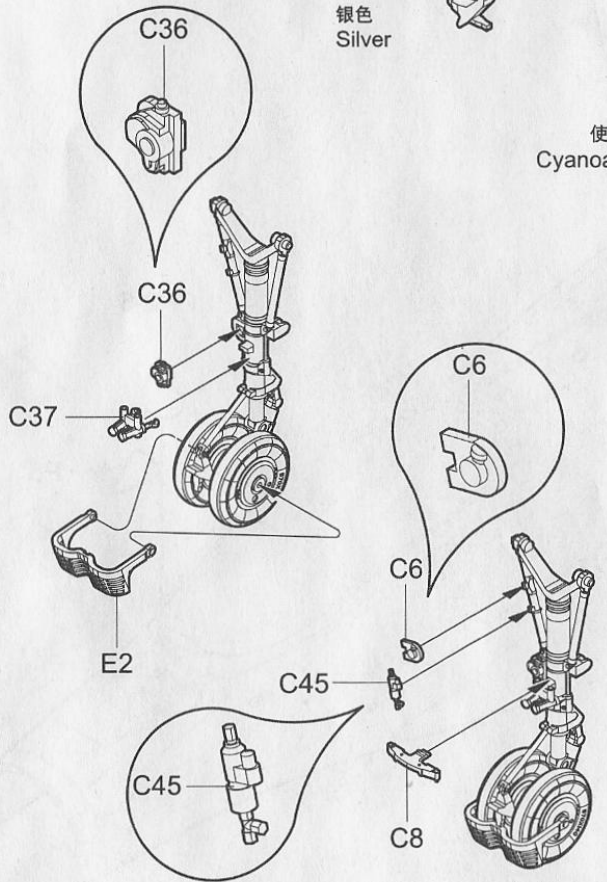
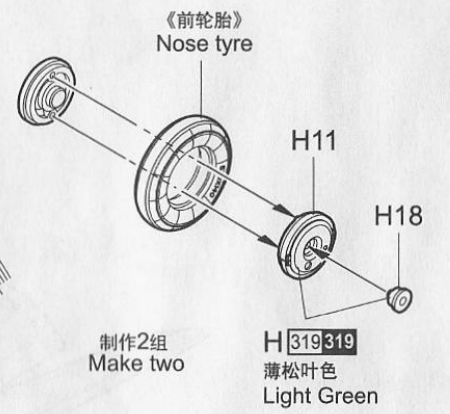
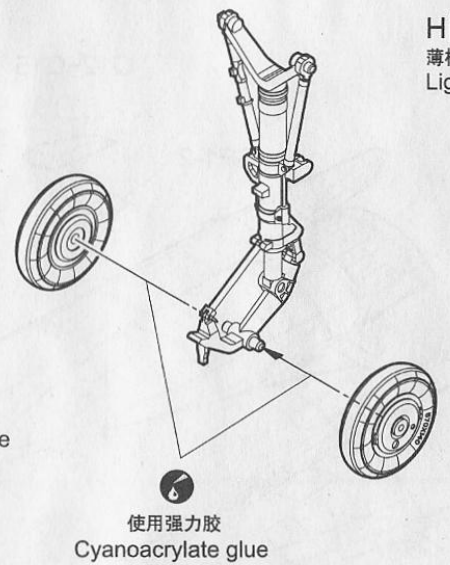
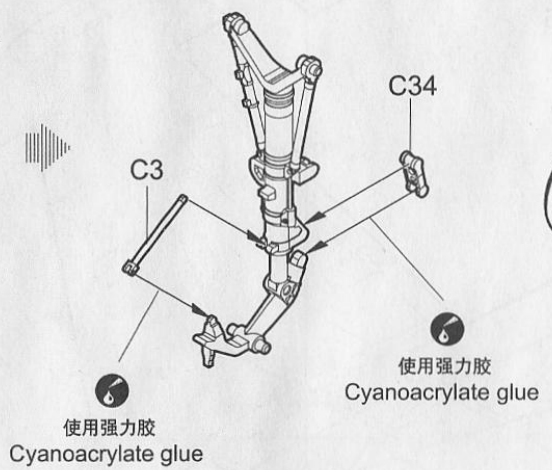
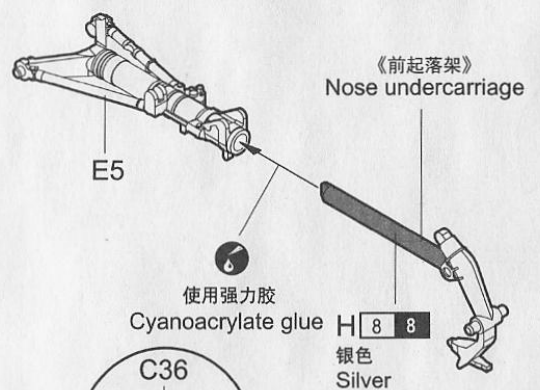

《前起落架》
Nose undercarriage

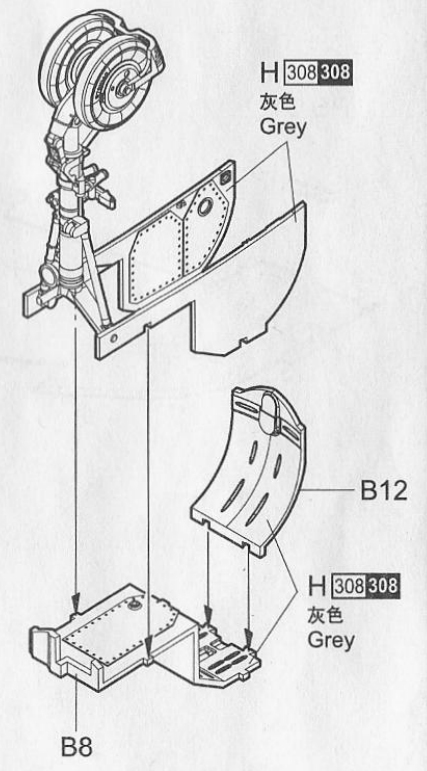

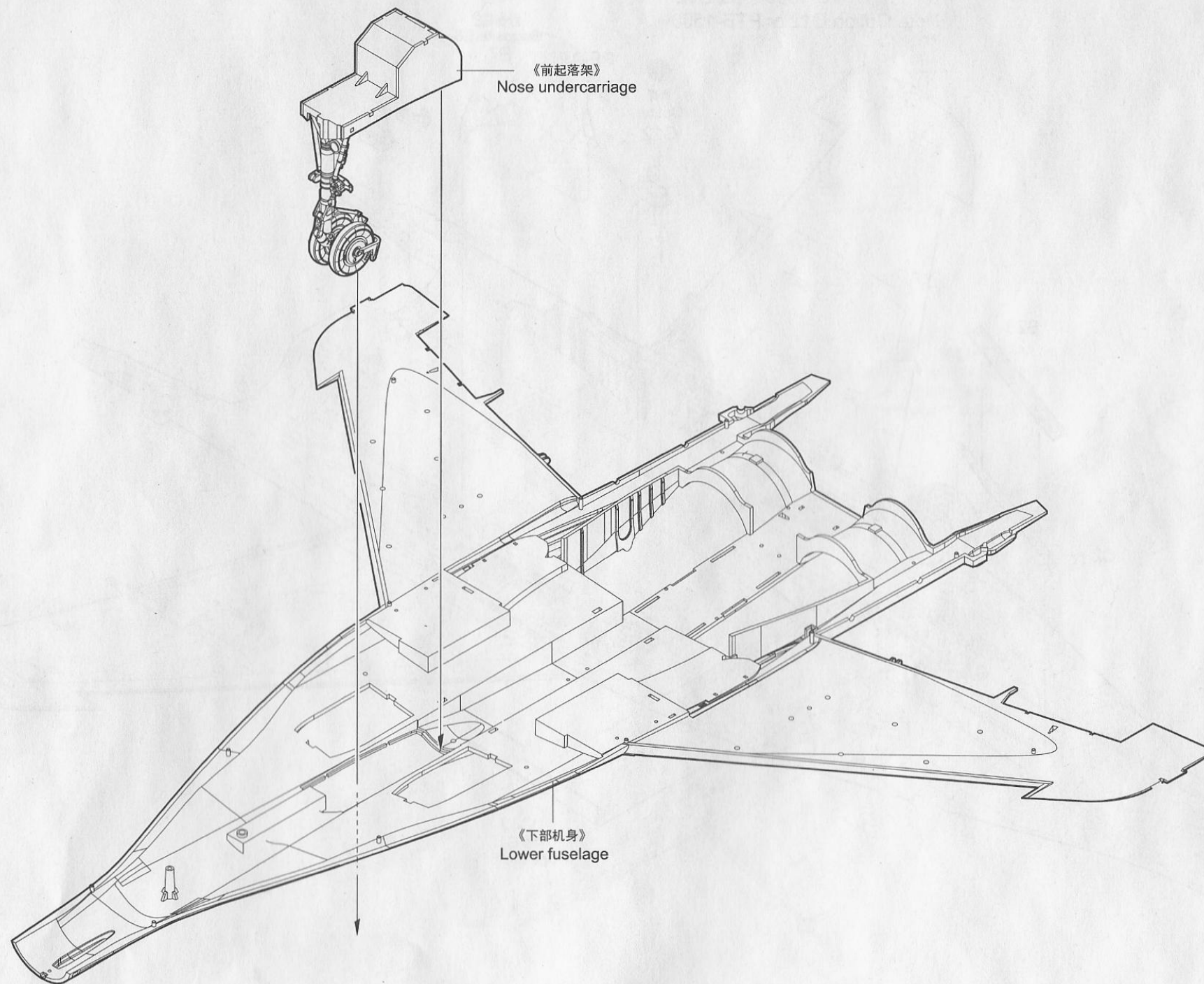

注：选择装PTB-1500时不装G12
Note: Option G12 or PTB-1500

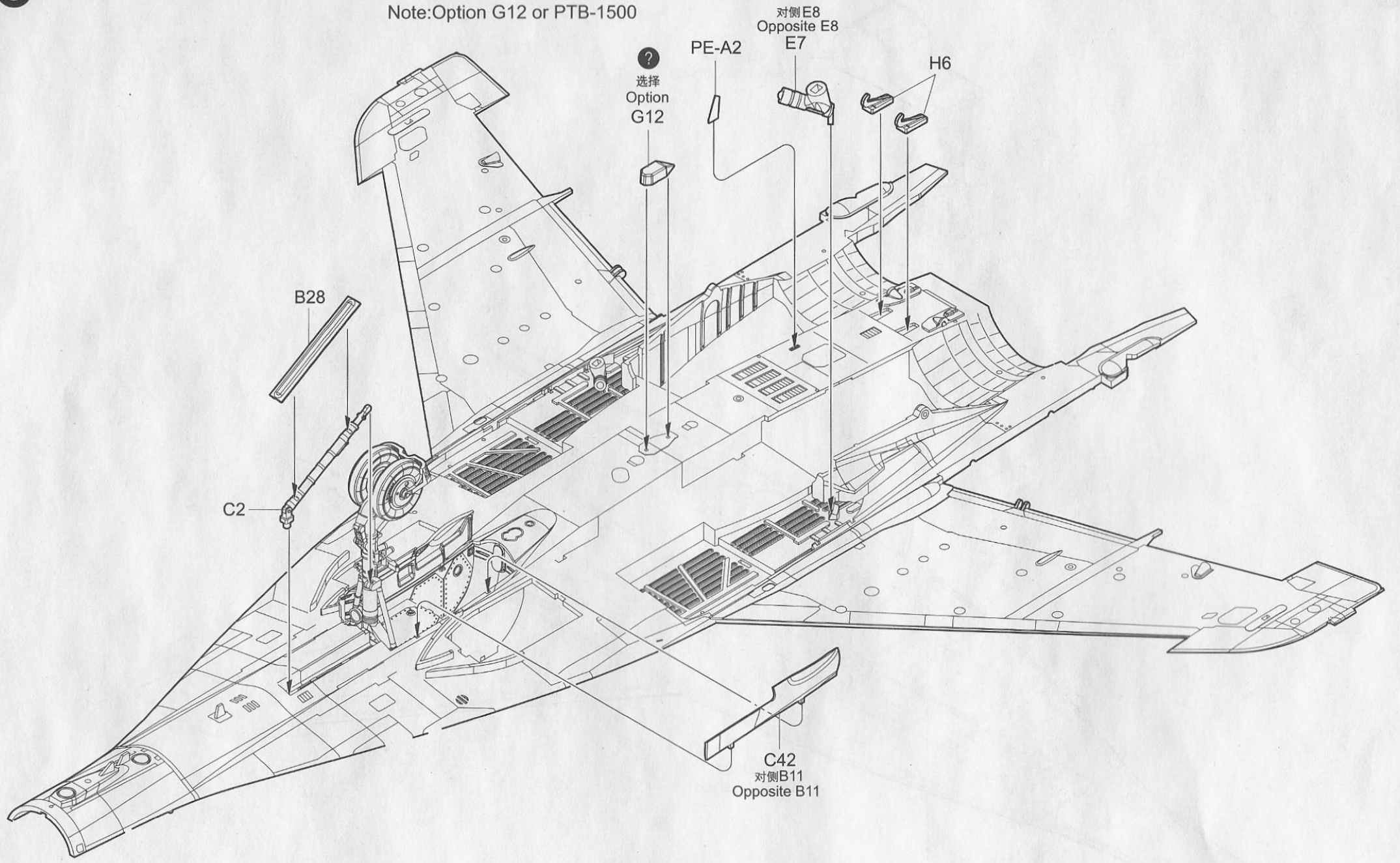

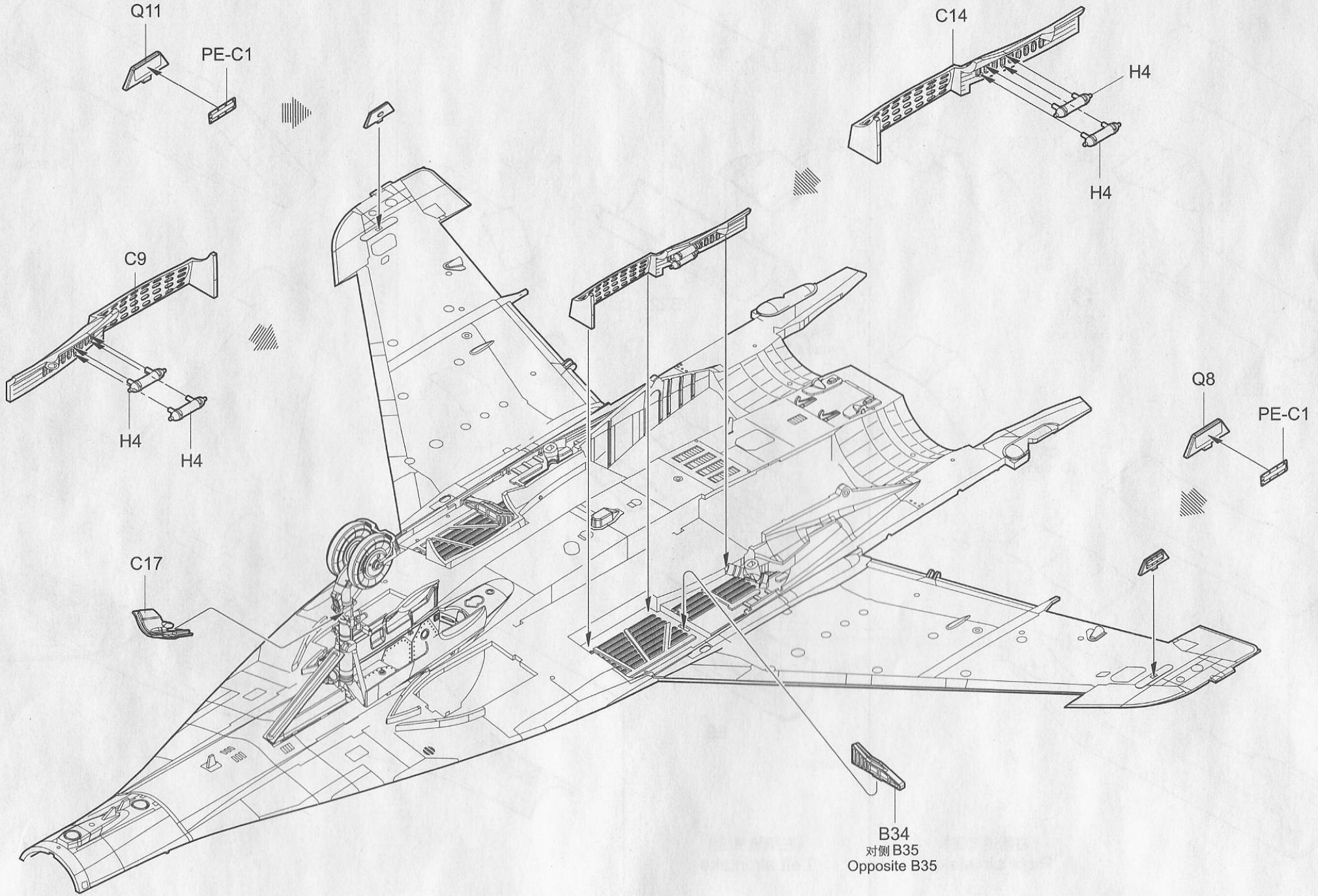

11

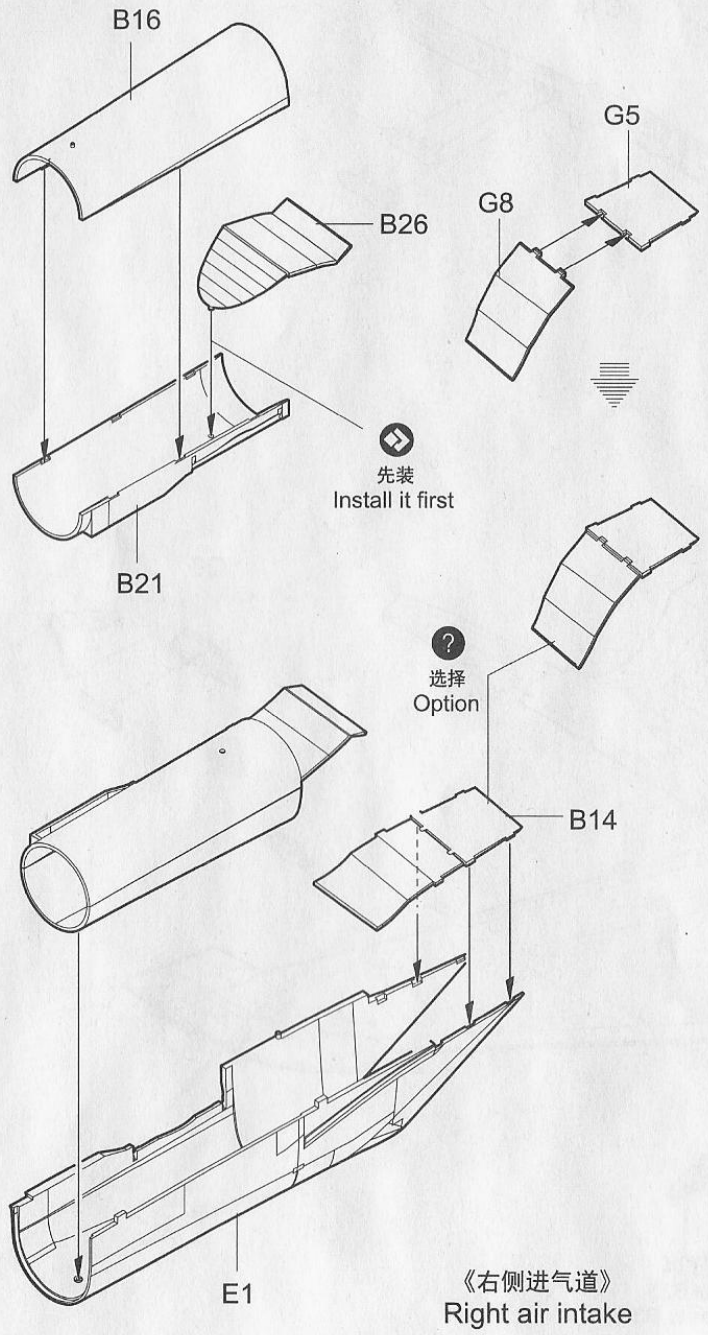

12

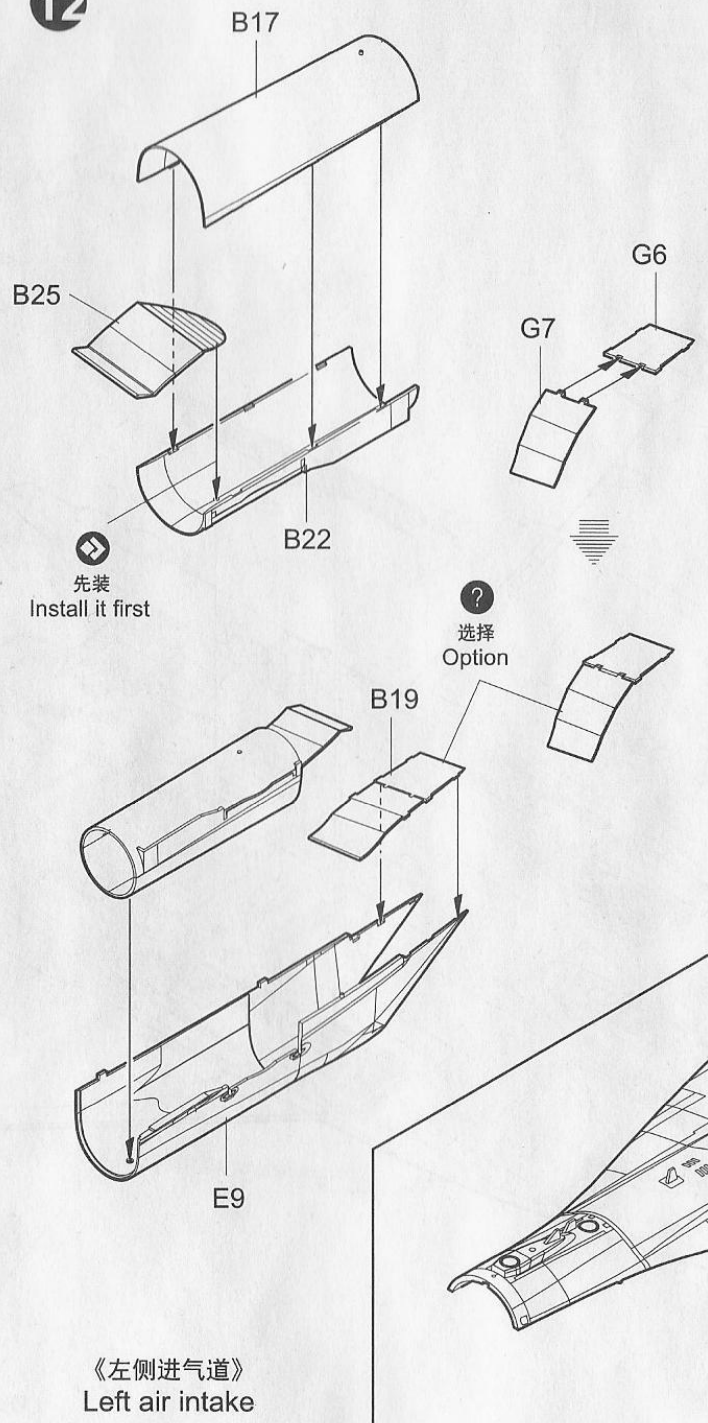

13

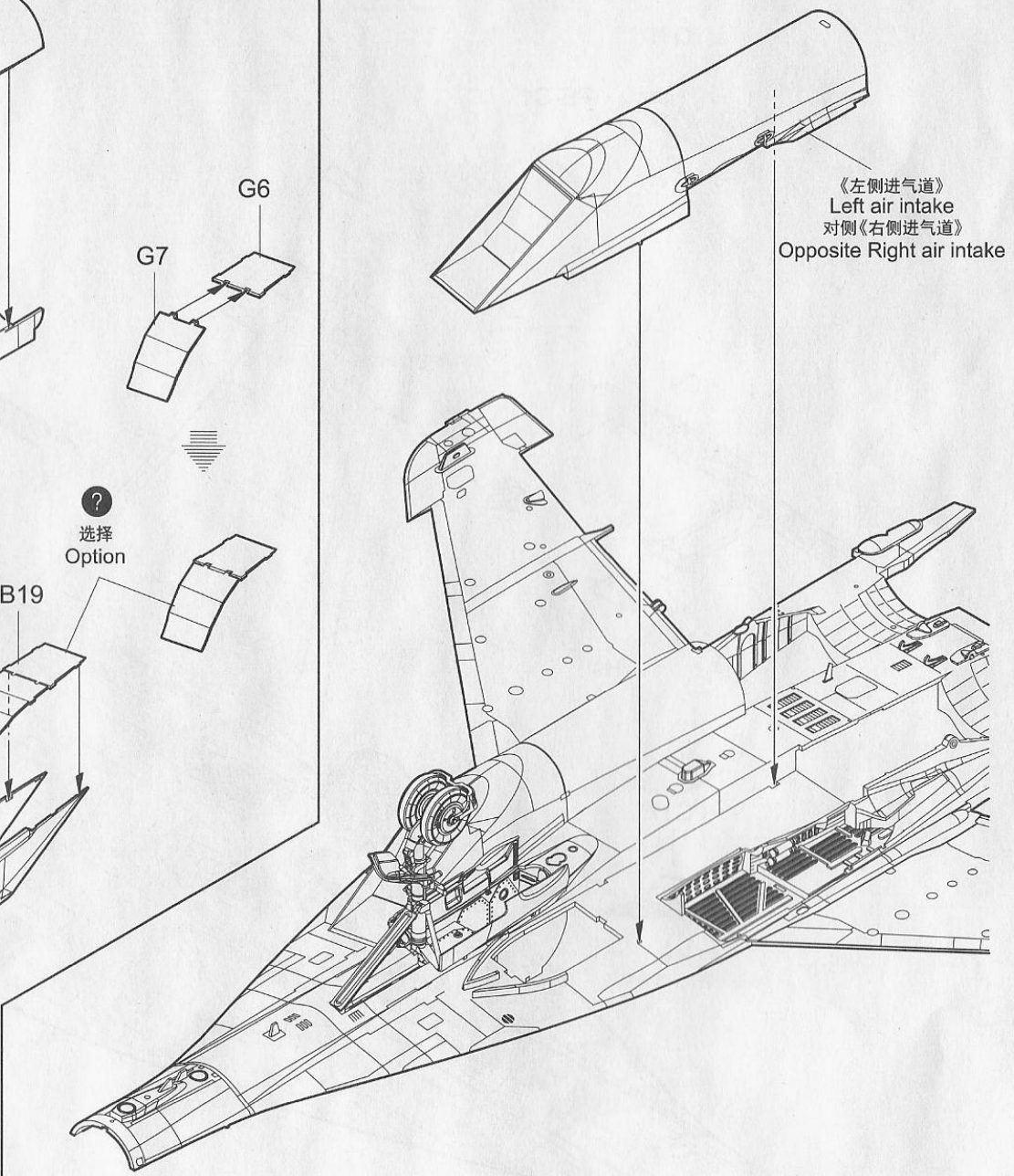

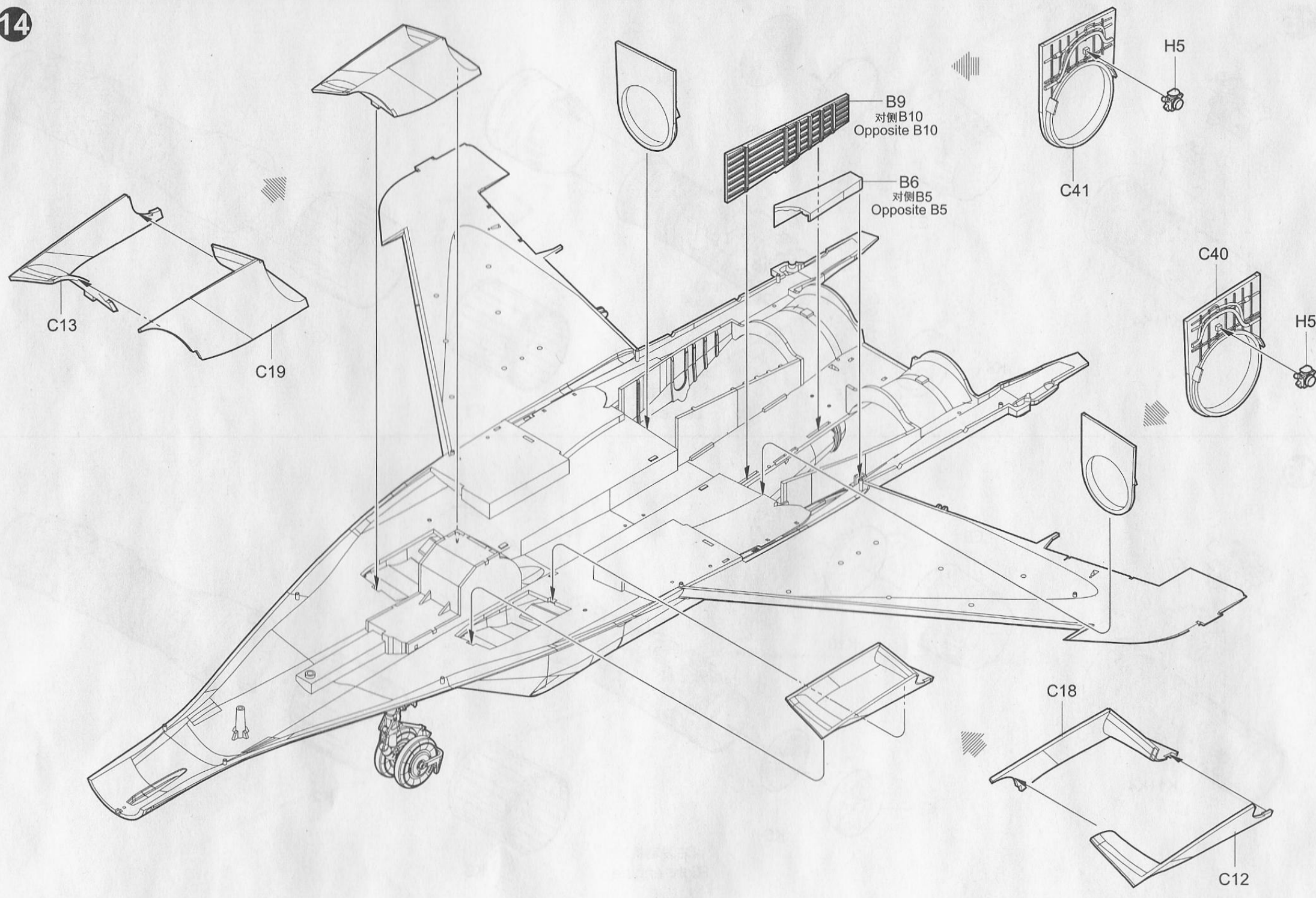

15

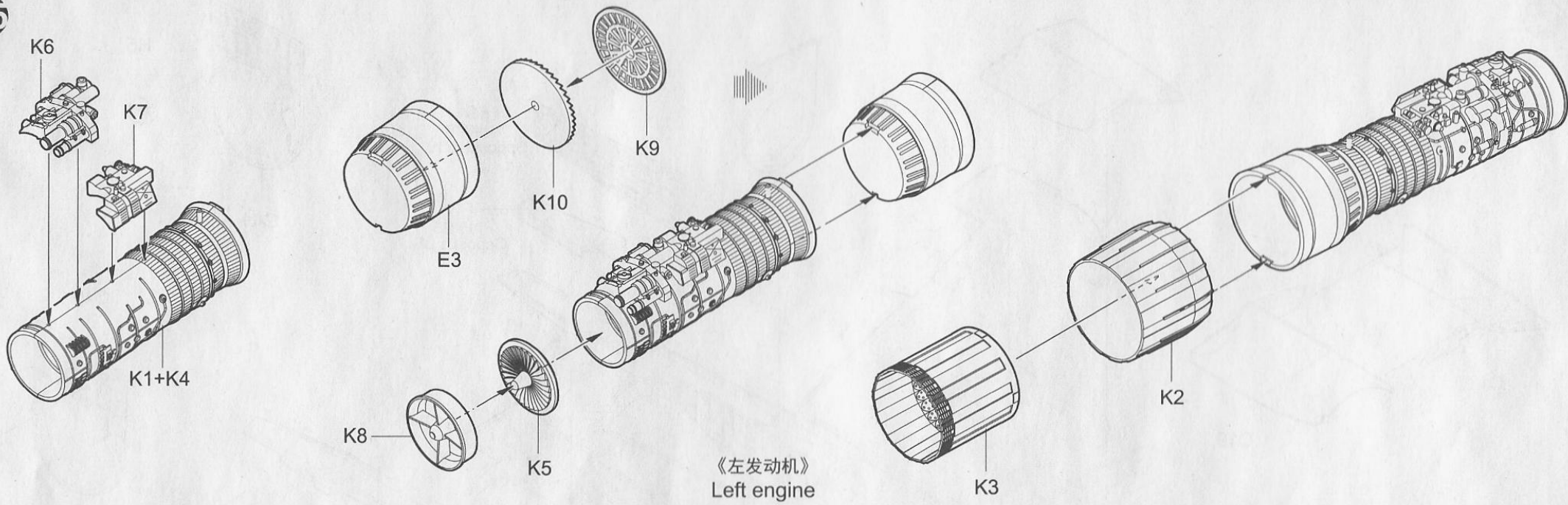

16

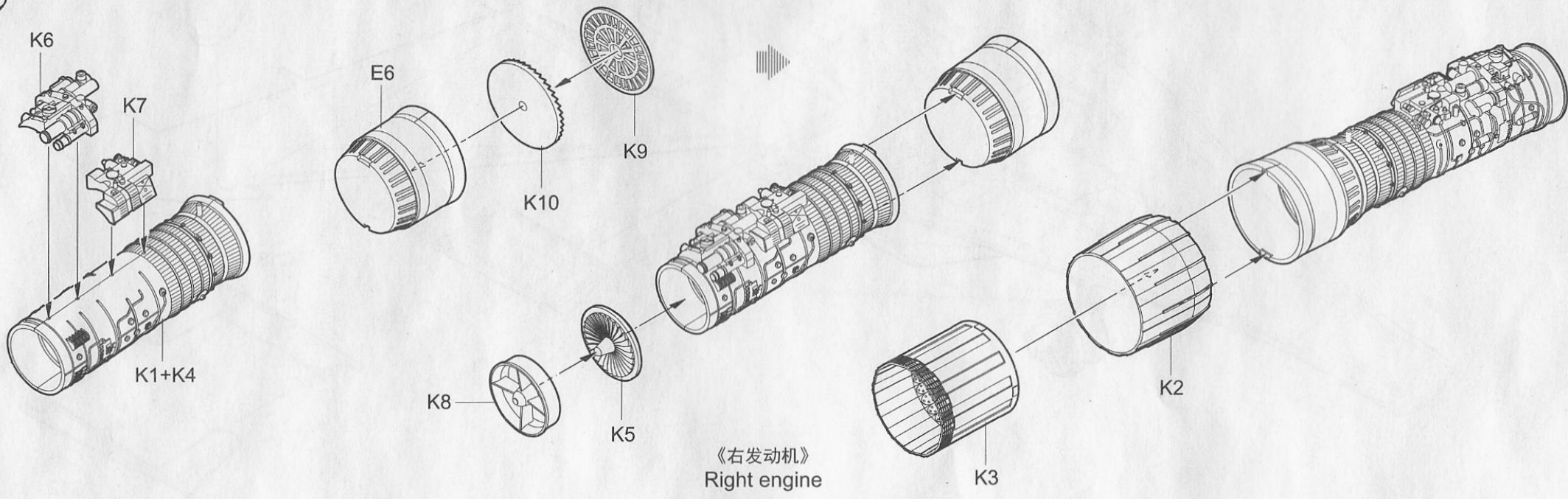

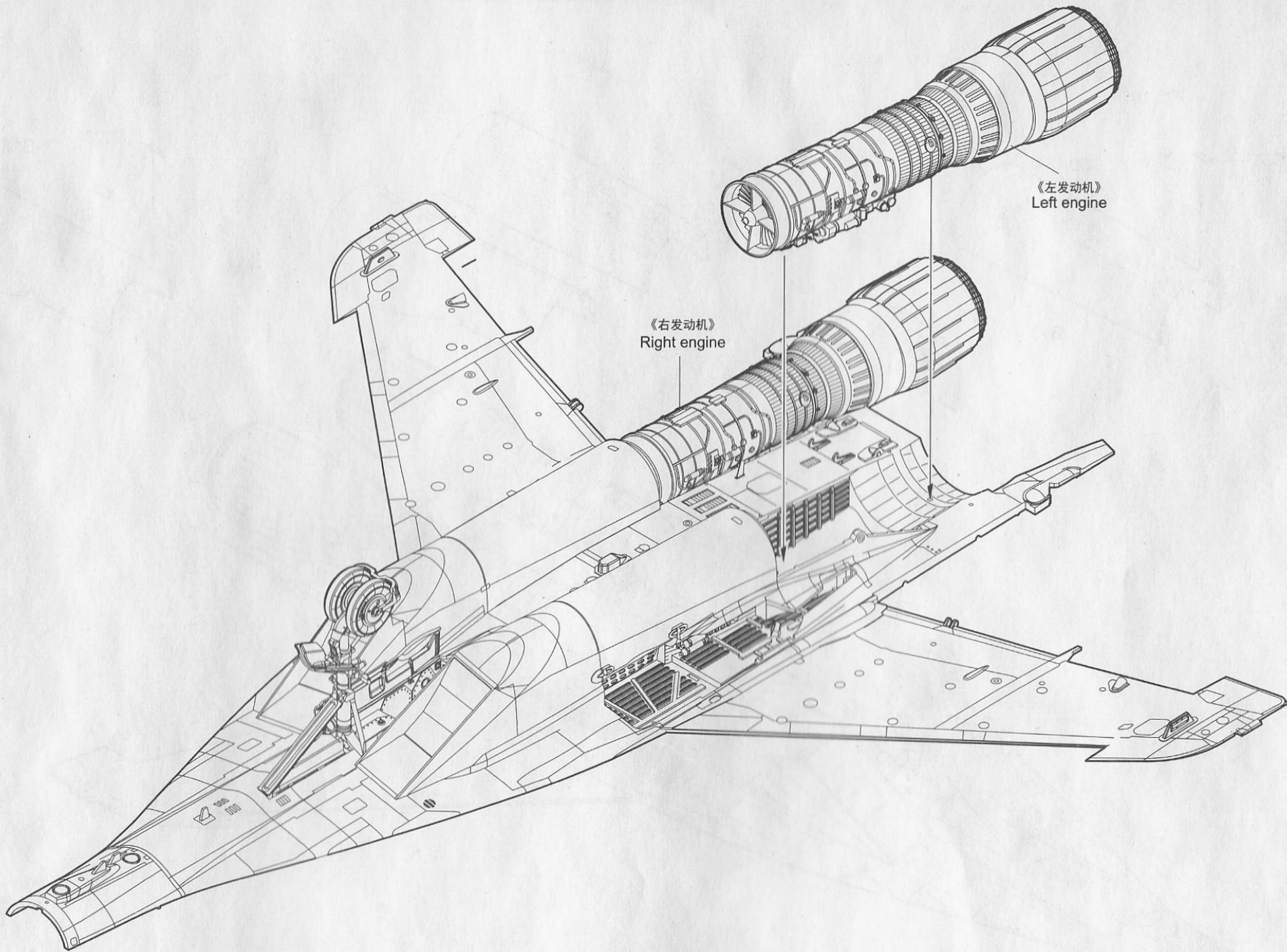

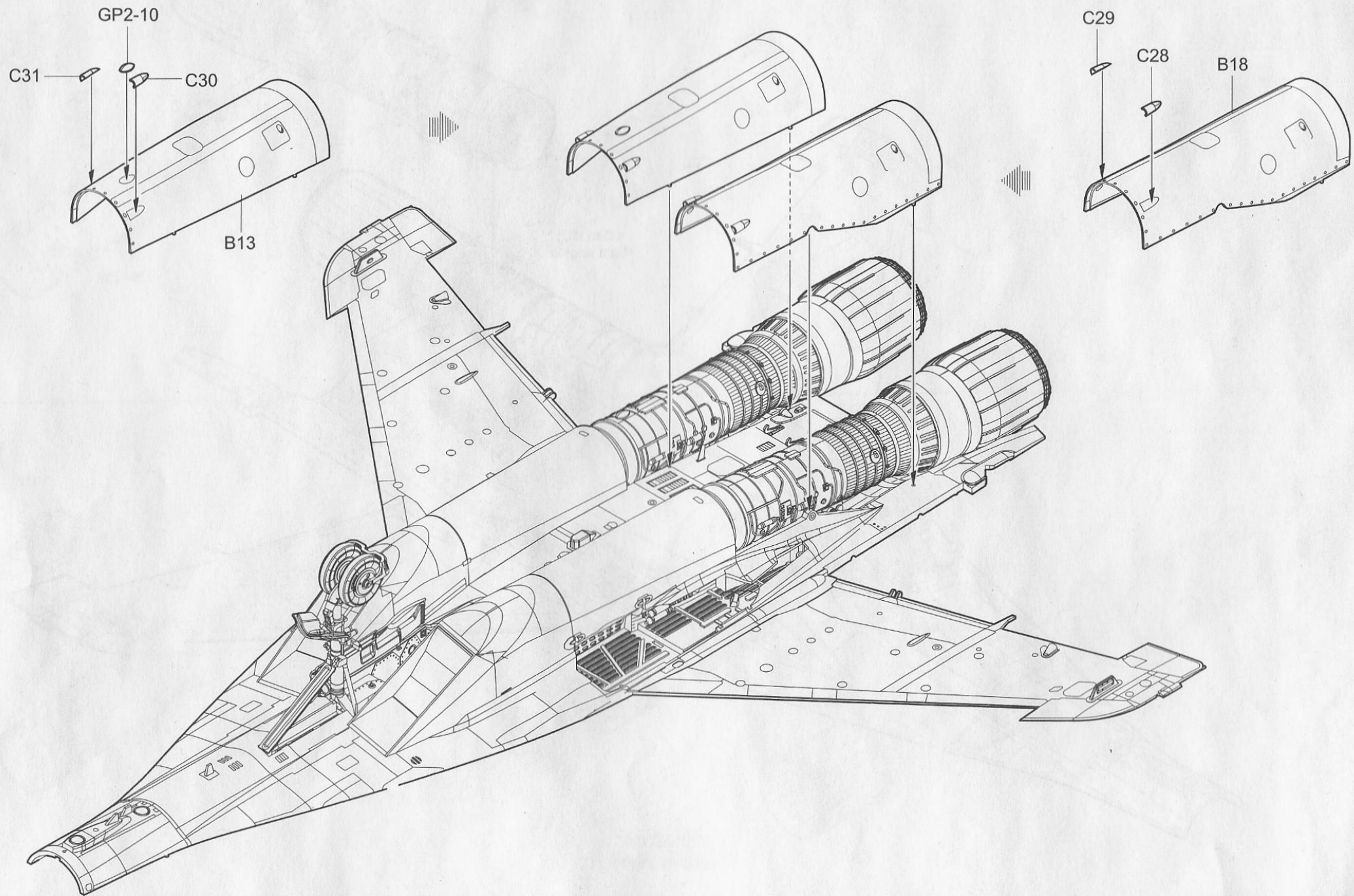

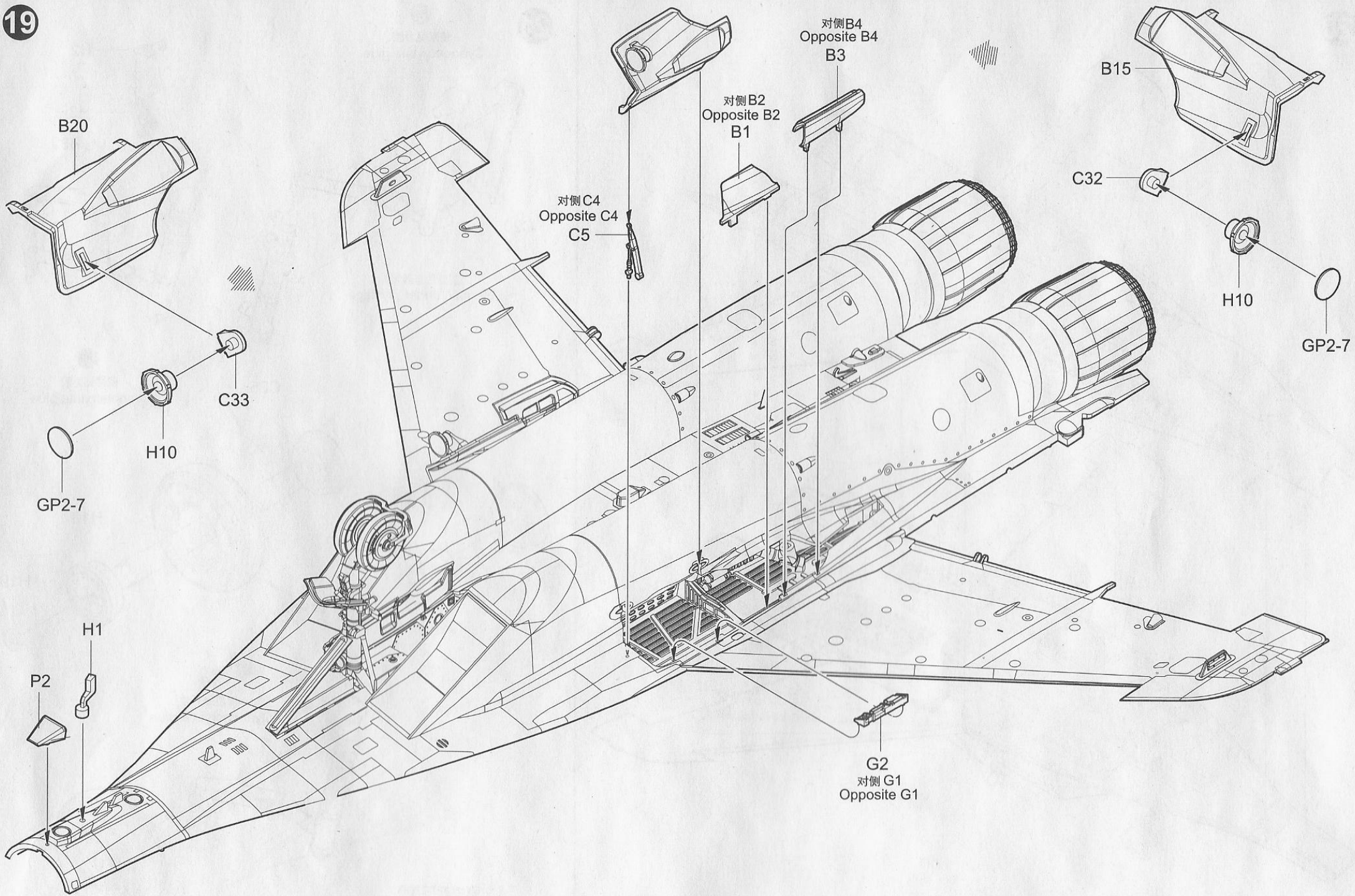

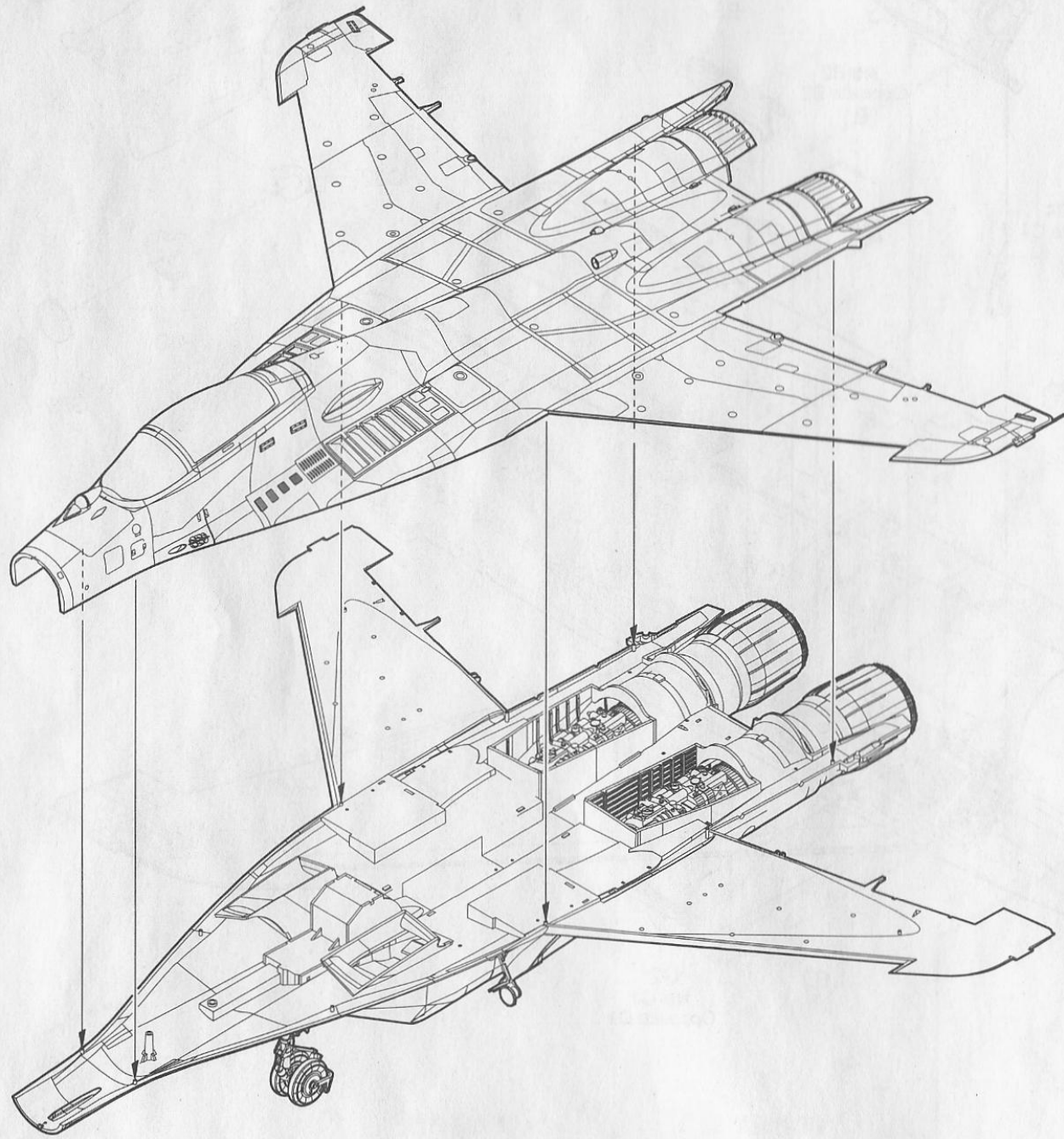

6
使用强力胶
Cyanoacrylate glue

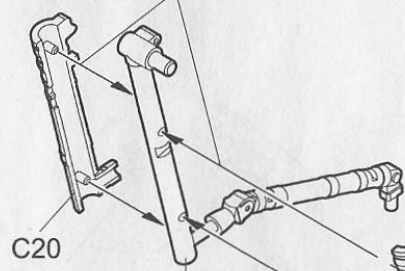

《左侧主起落架》
Left main undercayyiage

C25

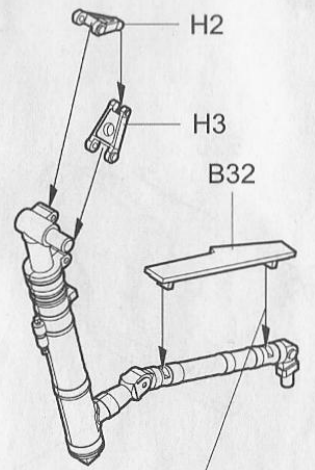

6
使用强力胶
Cyanoacrylate glue

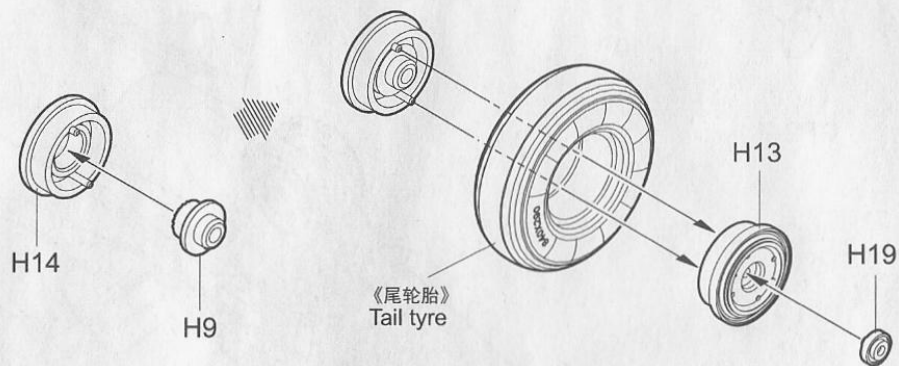

H14

H9

《尾轮胎》
Tail tyre

H13

H19

6
使用强力胶
Cyanoacrylate glue

《左侧主起落架》
Left main undercayyiage

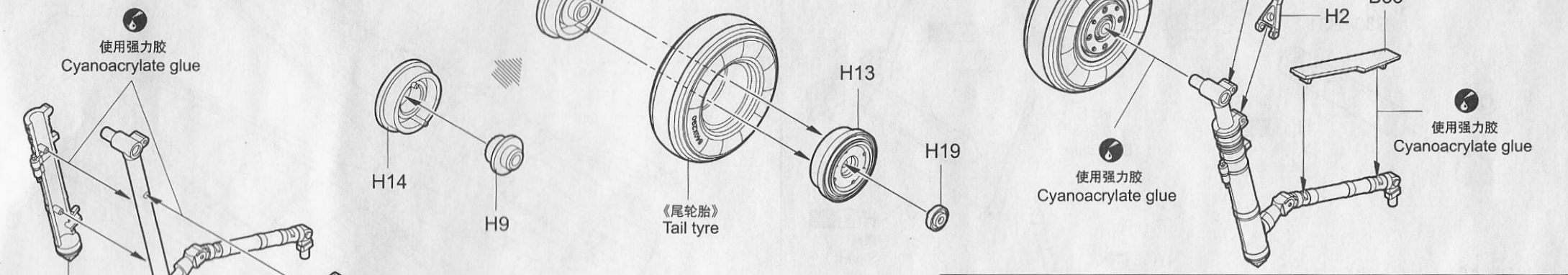

《右侧主起落架》
Right main undercayyiage

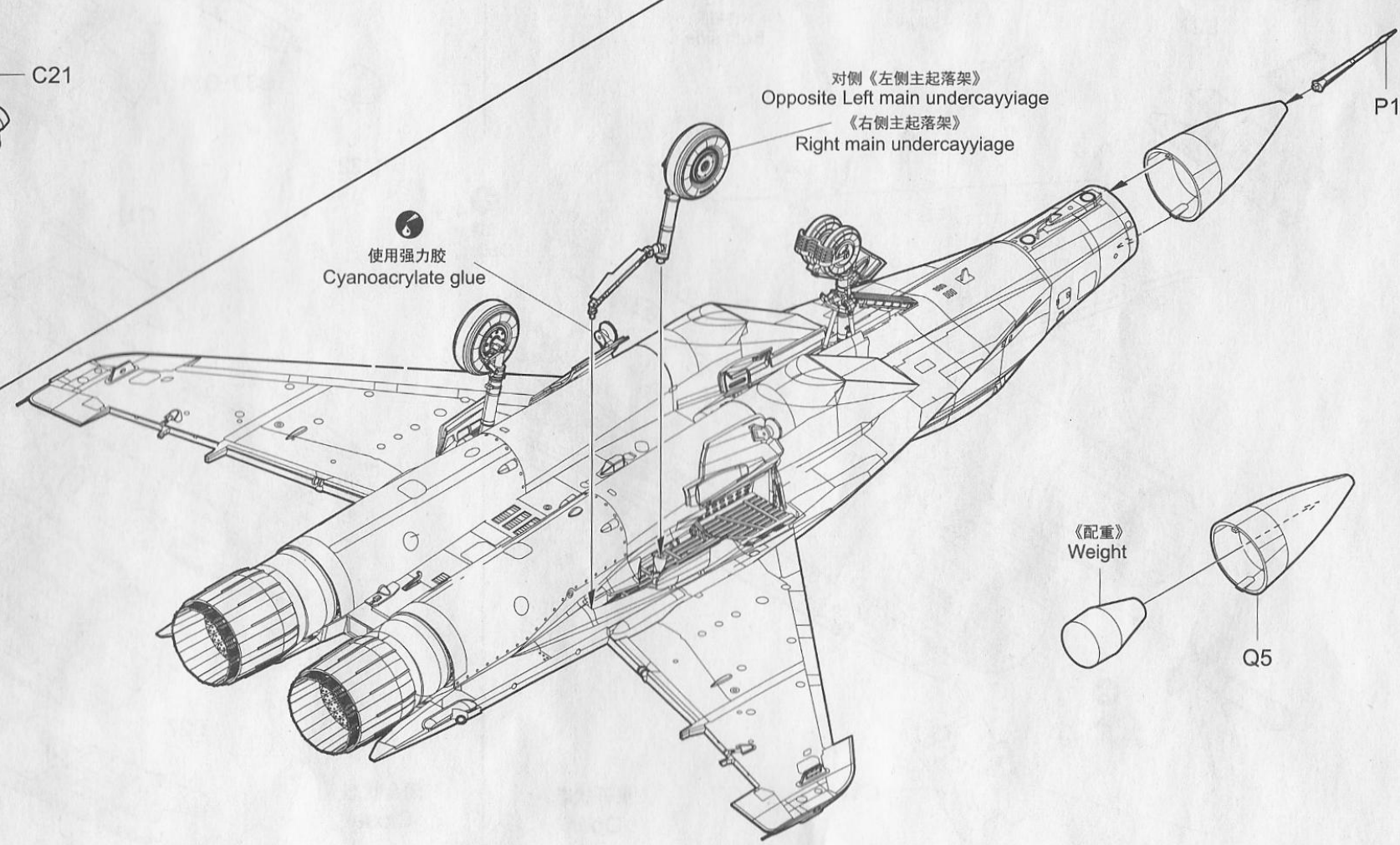

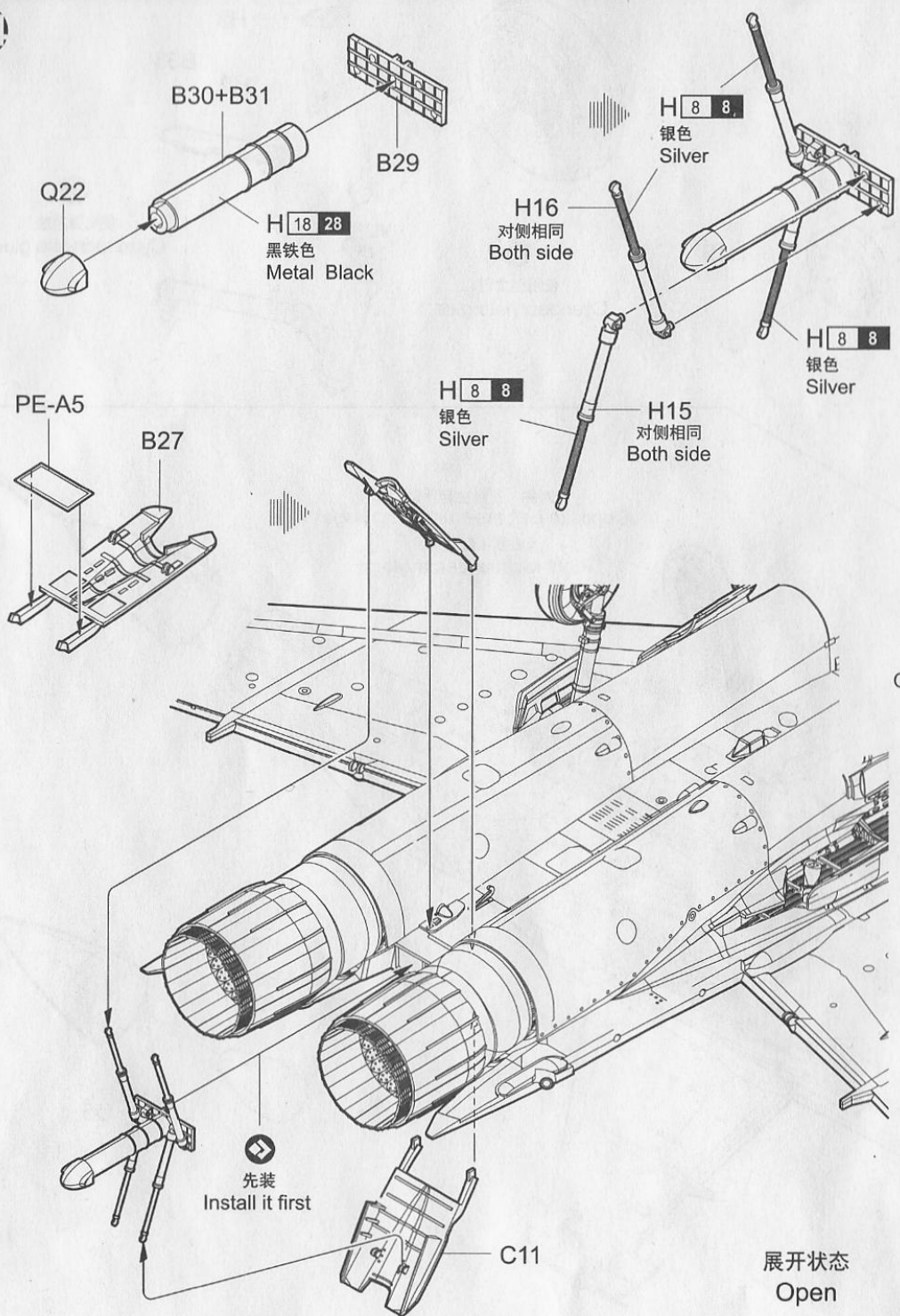

?
选择
Option

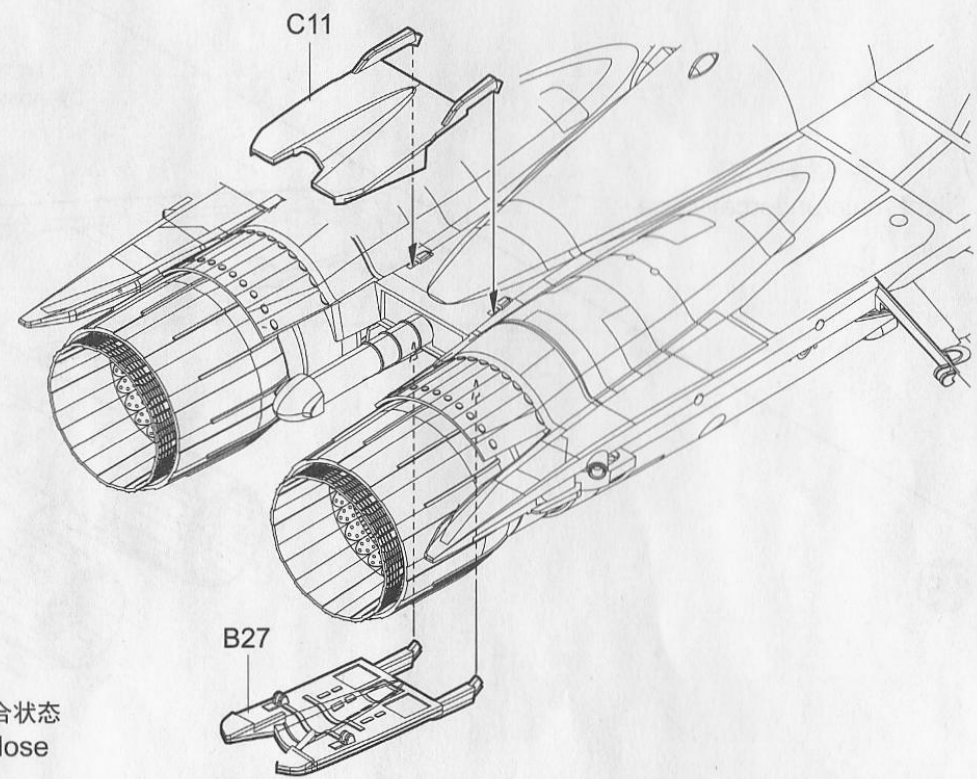
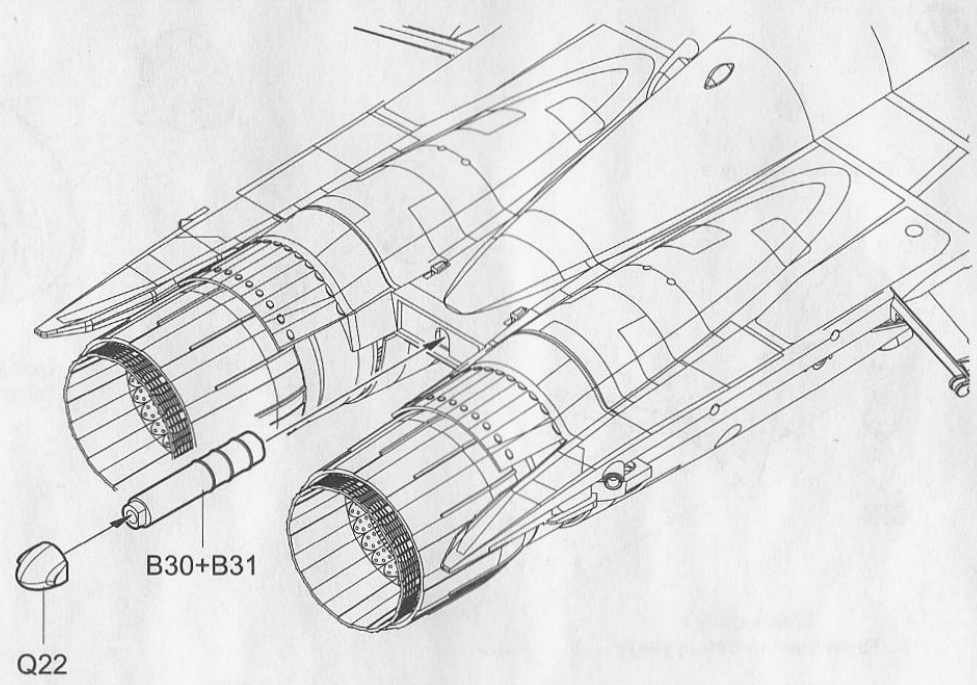

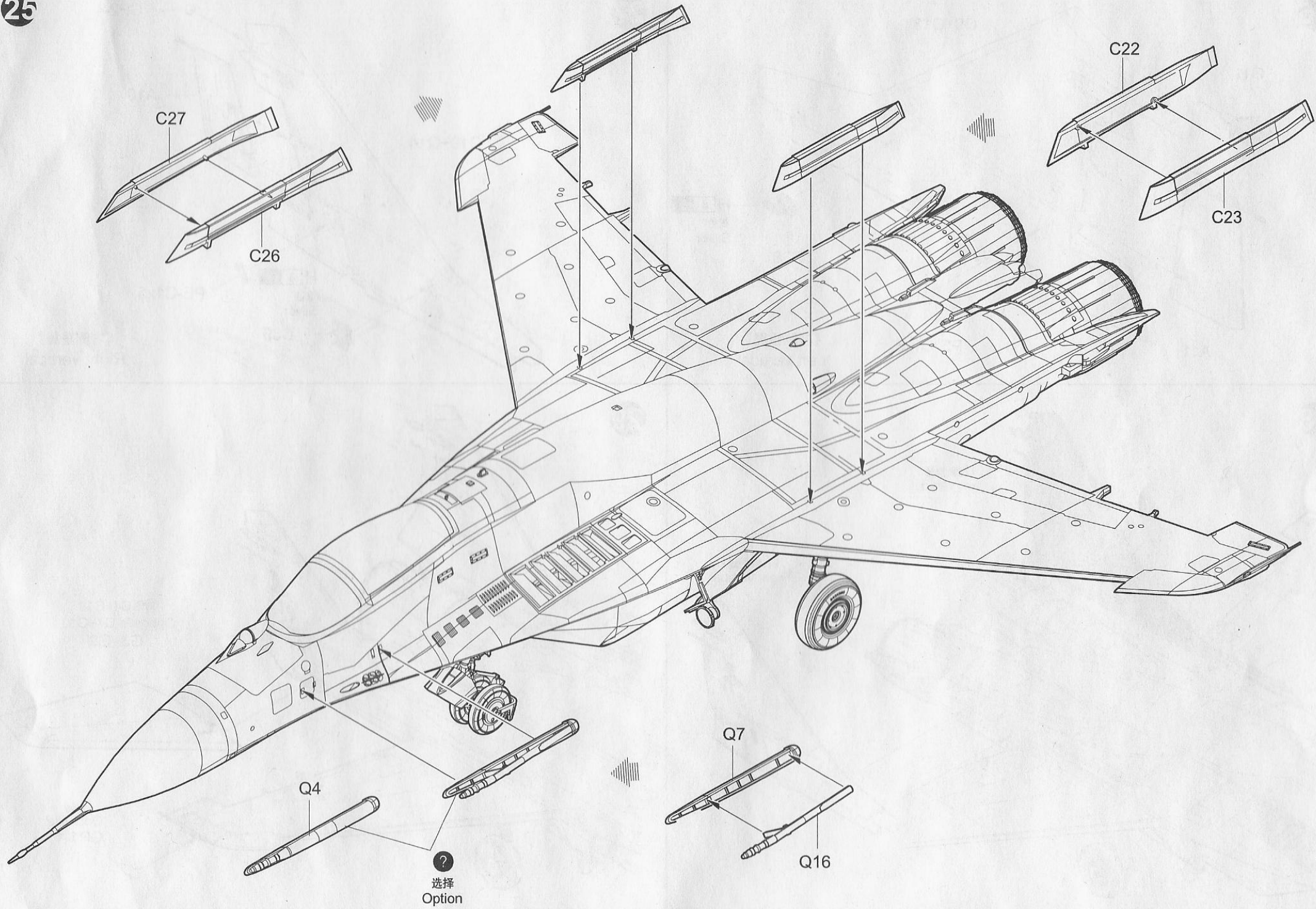

C27

C26

C22

C23

Q4

Q7

Q16

?

选择
Option

26

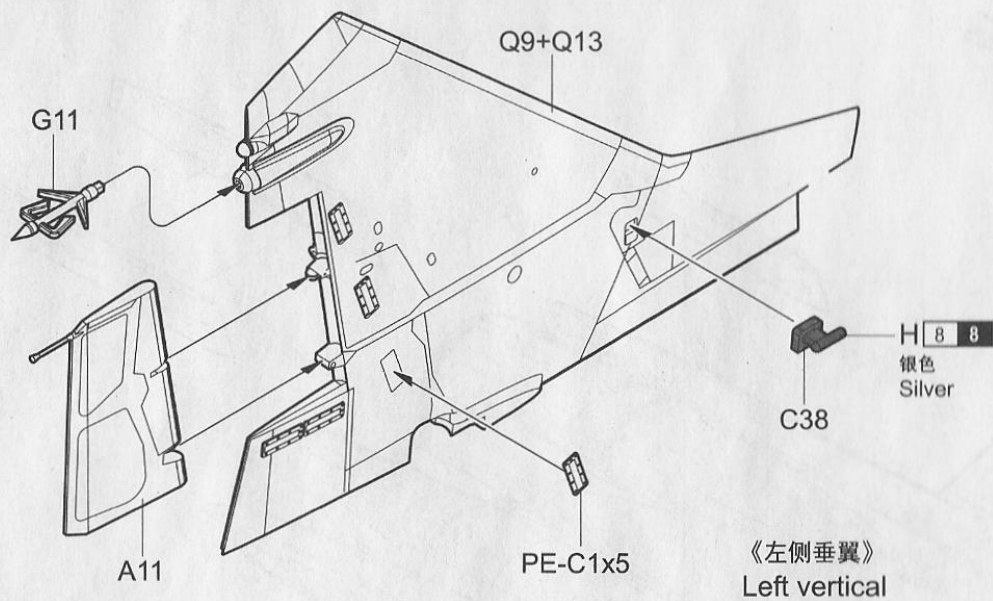

27

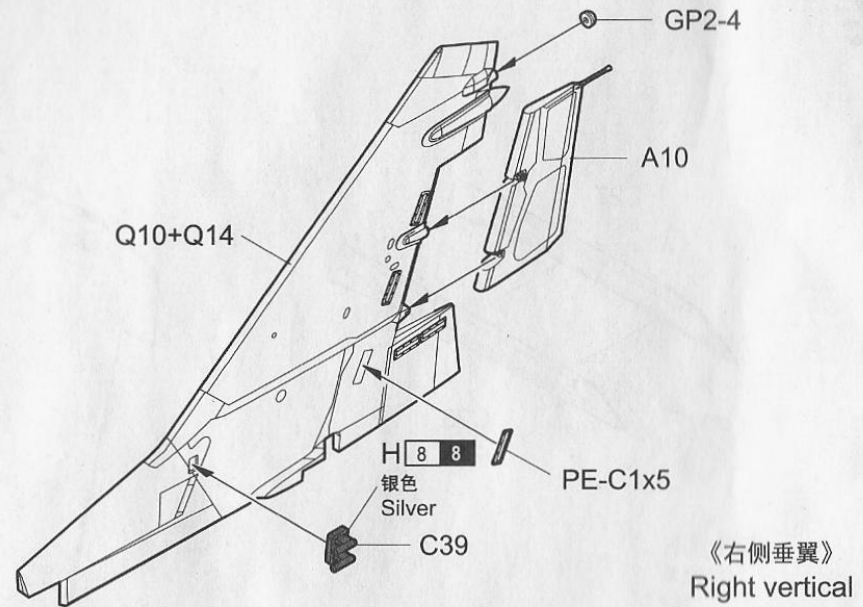

28

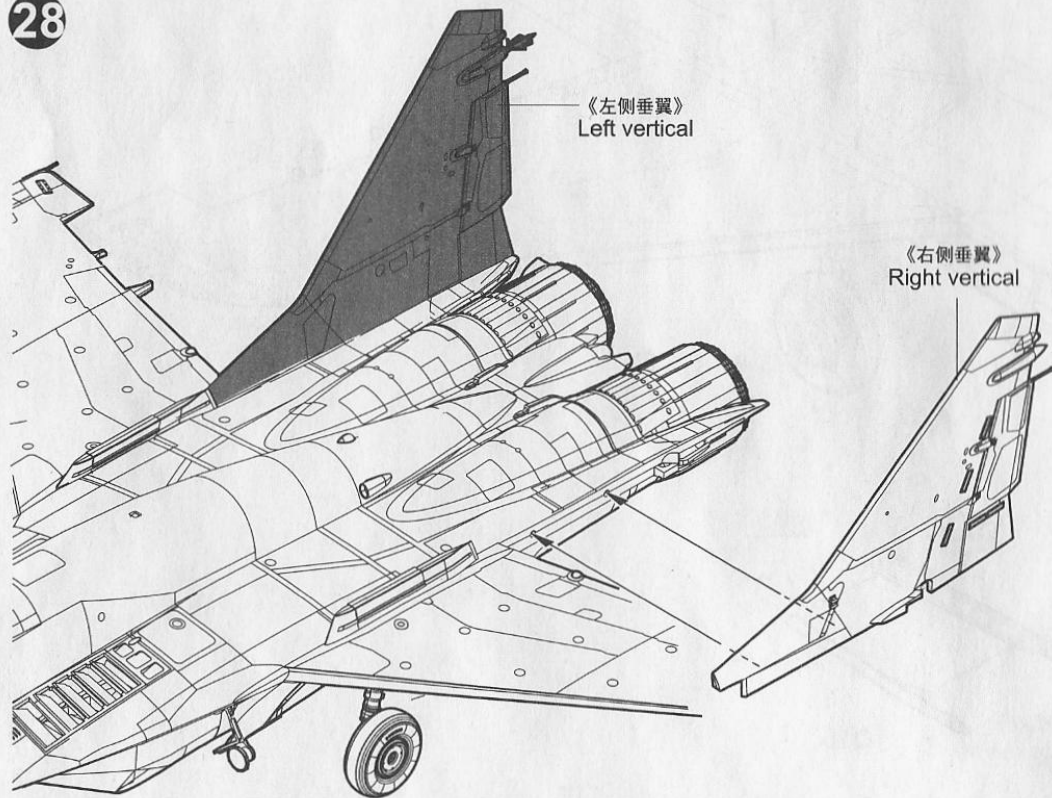

29

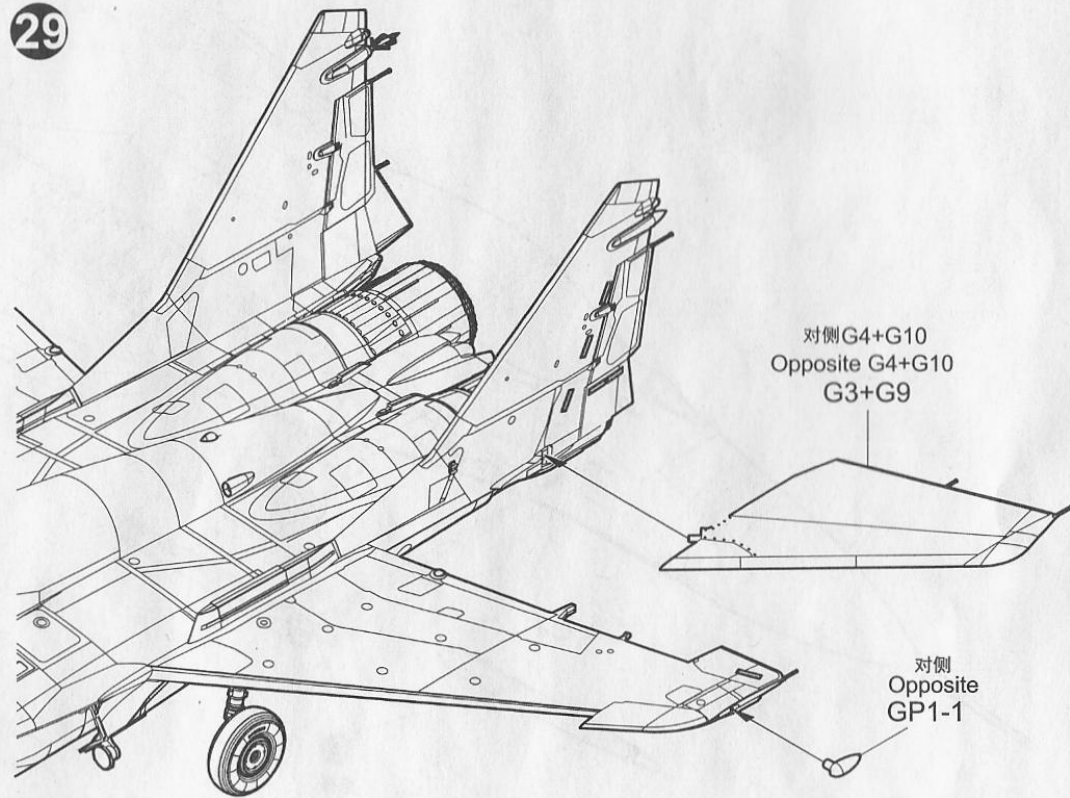

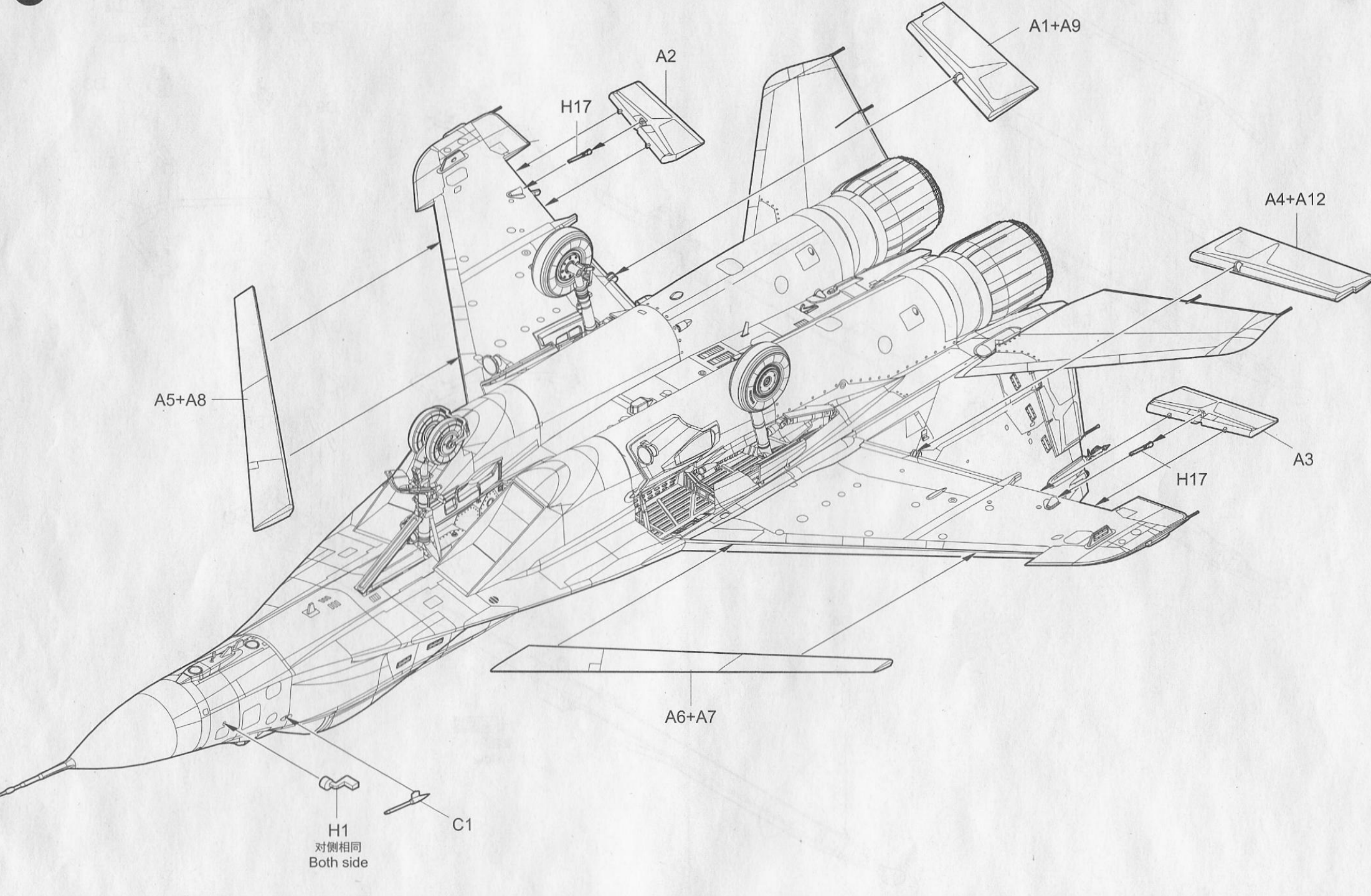

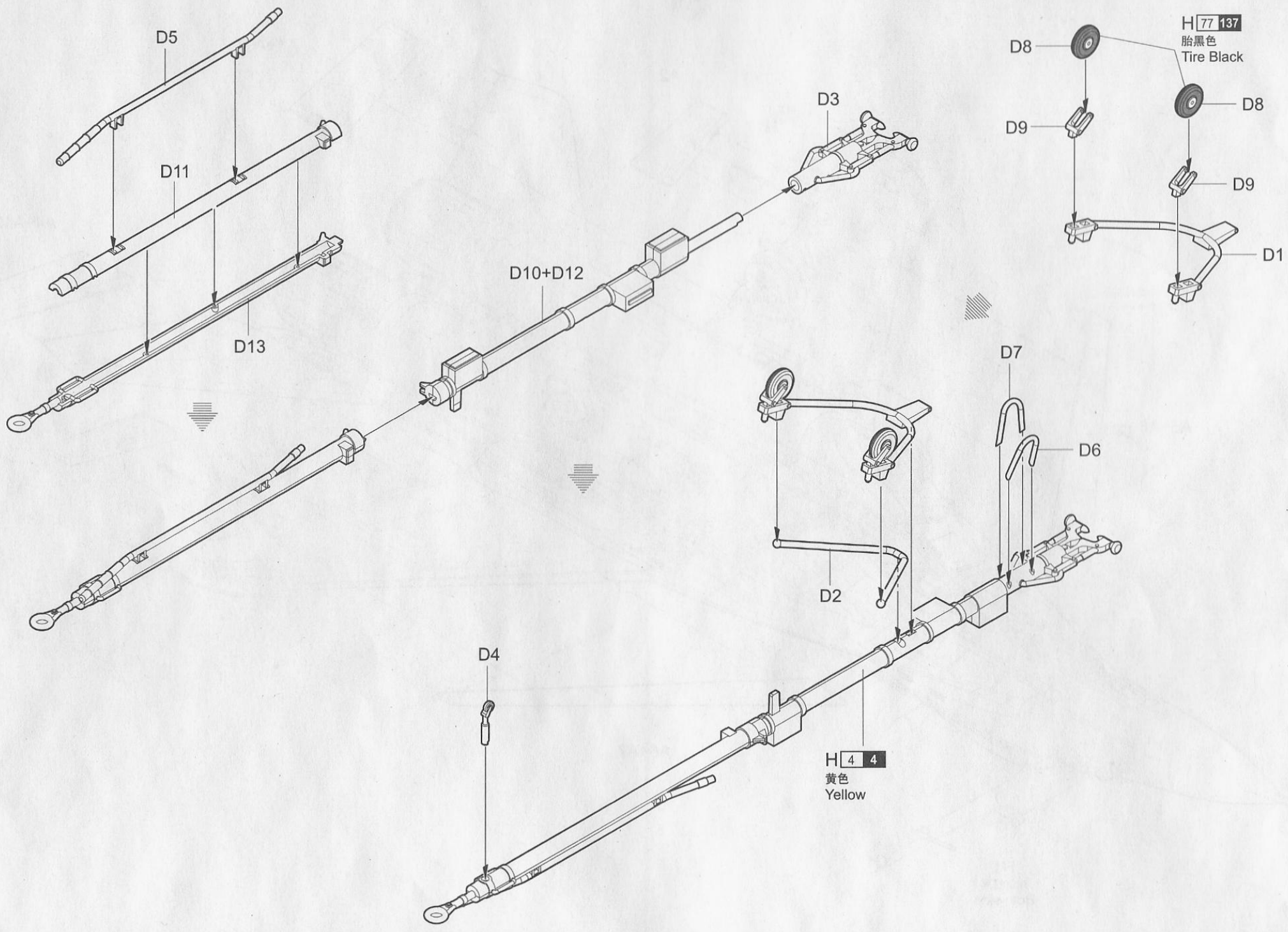

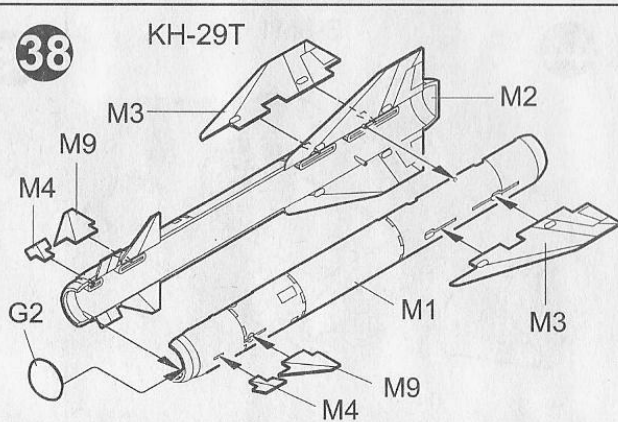
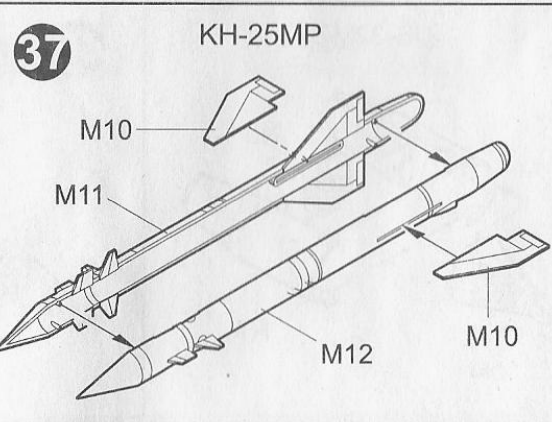
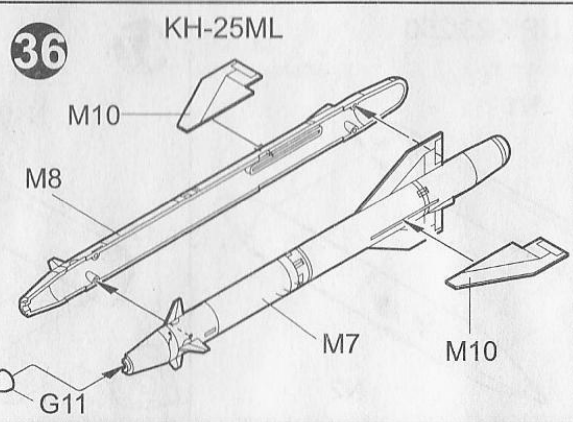
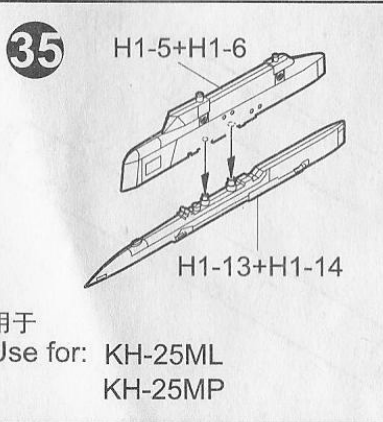
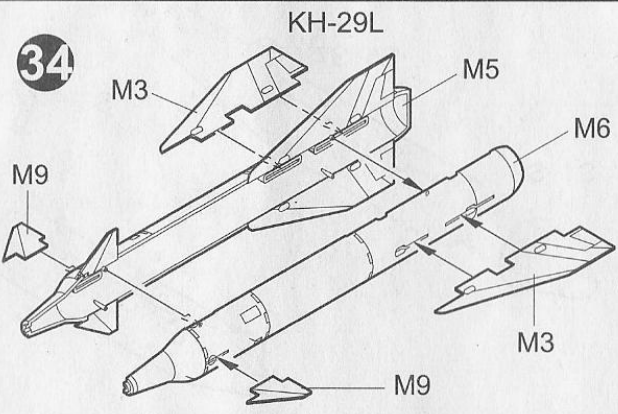
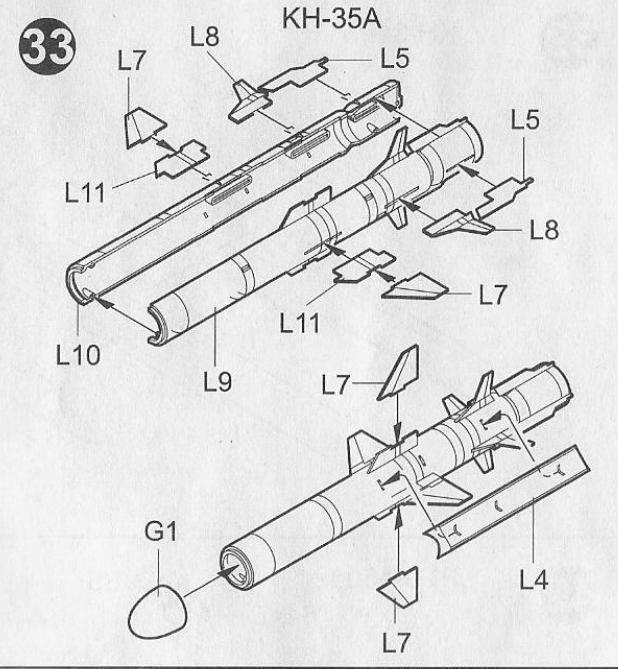
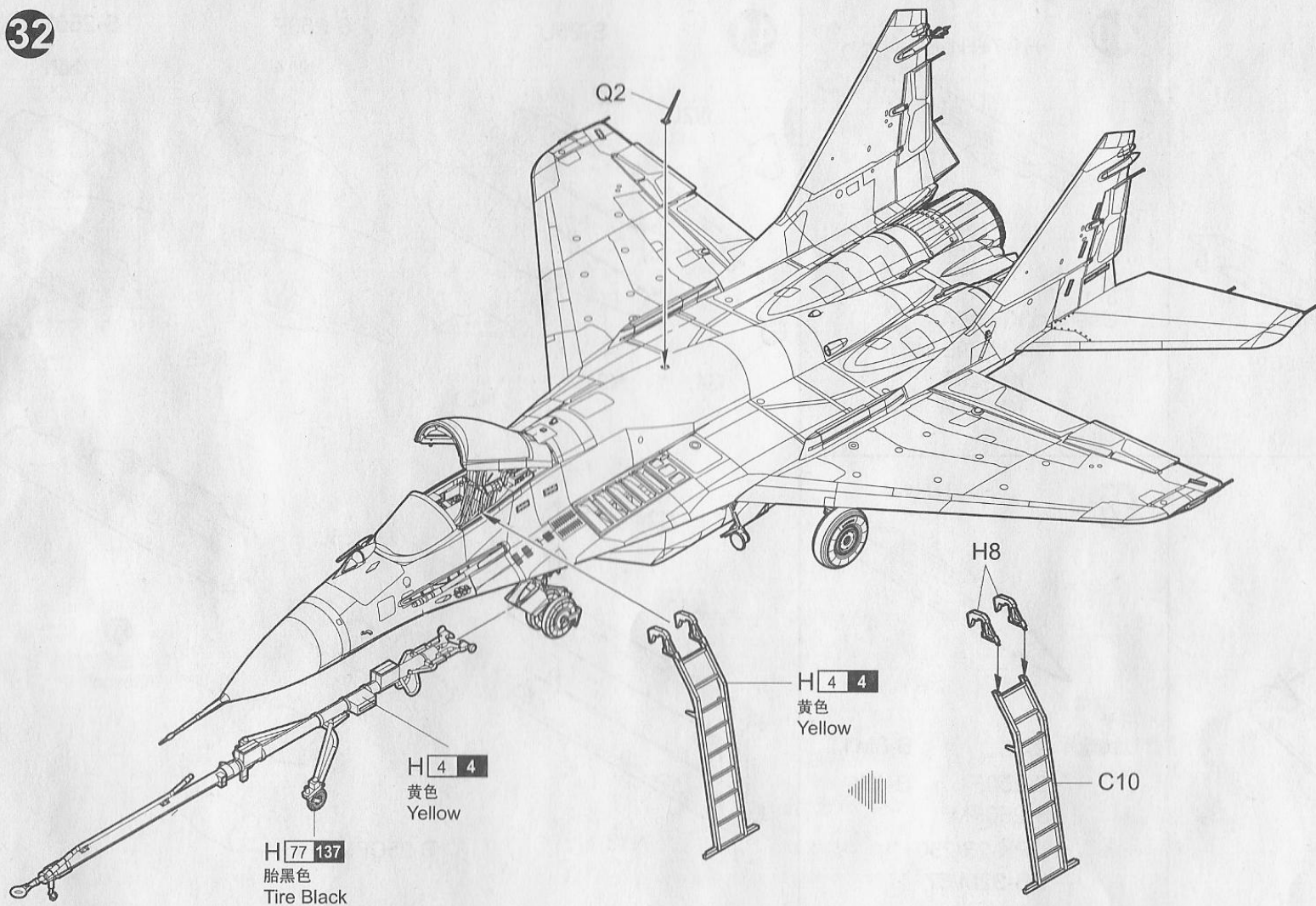

39

KH-31P

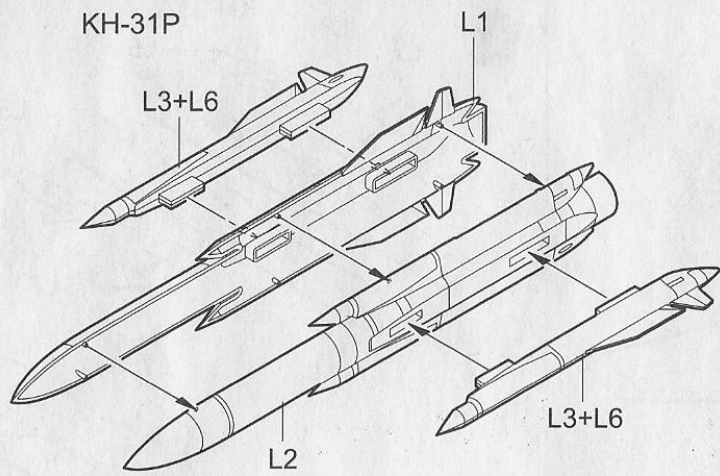

40

H1-7+H1-8

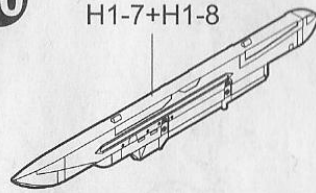

用于

Use for: KH-35A
KH-29L
KH-29T
KH-31P

41

S-25L

S-250F

S-250FM

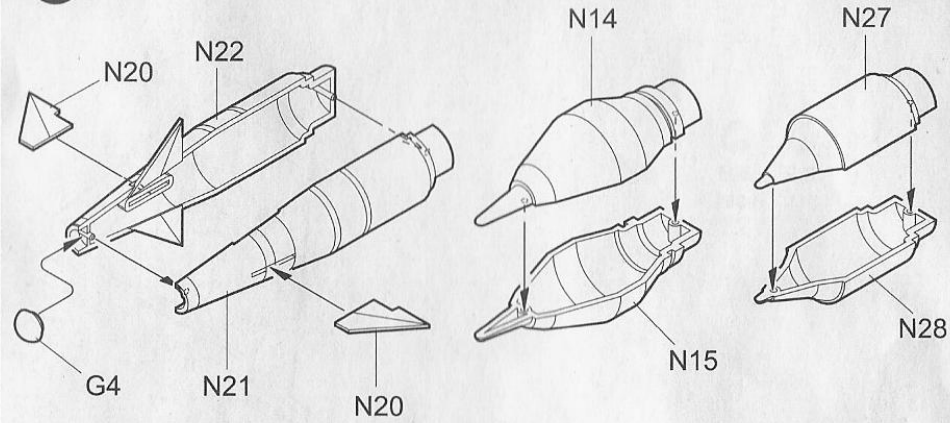

42

PTB-1500

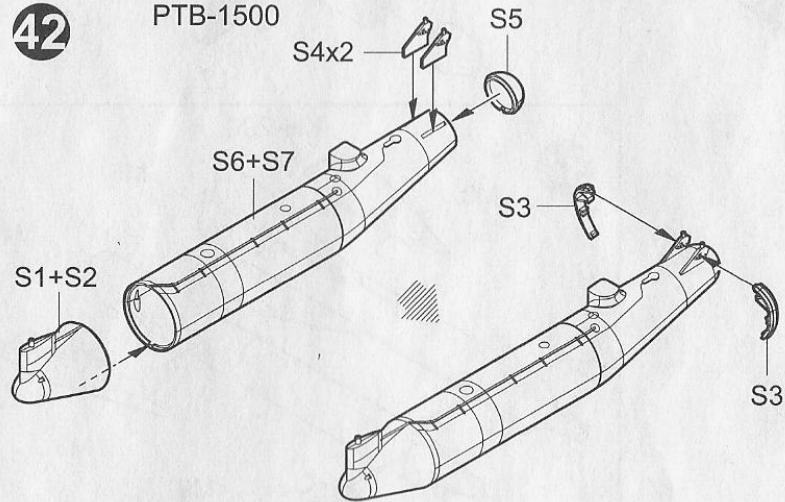

43

H1-3+H1-4

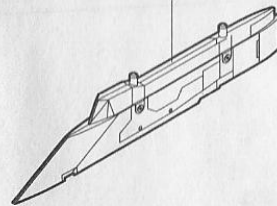

用于

Use for: S-25L B-8M1
S-250F B-13L
S-250FM
UPK-23/250
UB-32M/57

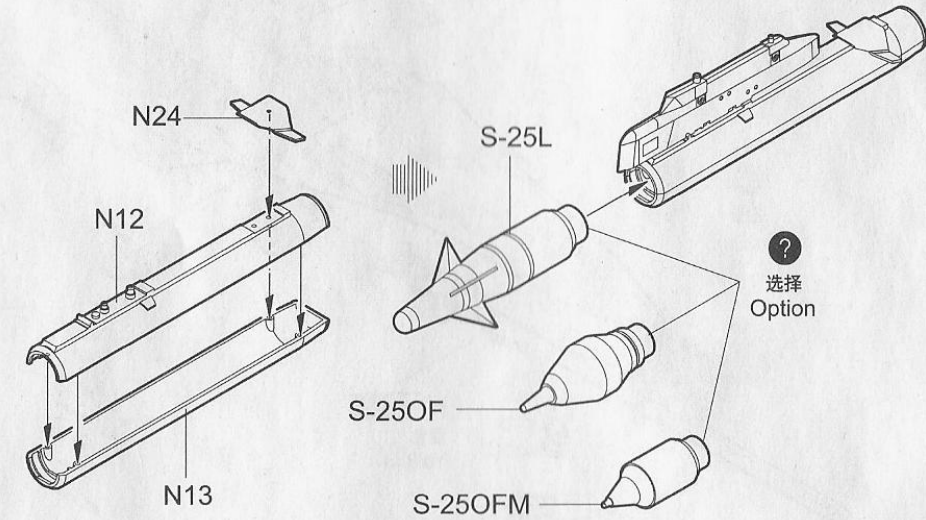

44

B-8M1

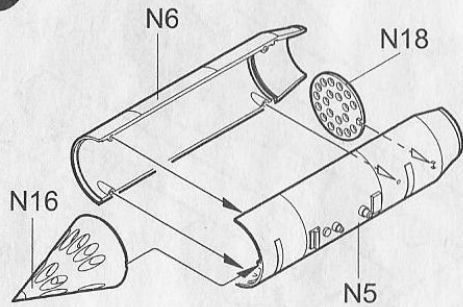

45

UB-32M/57

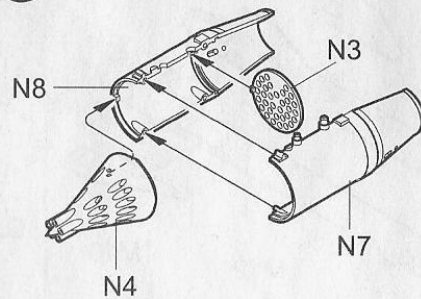

46

UPK-23/250

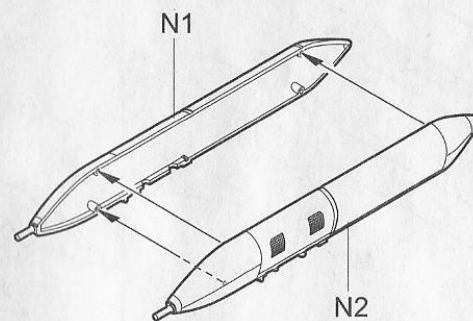

47

B-13L

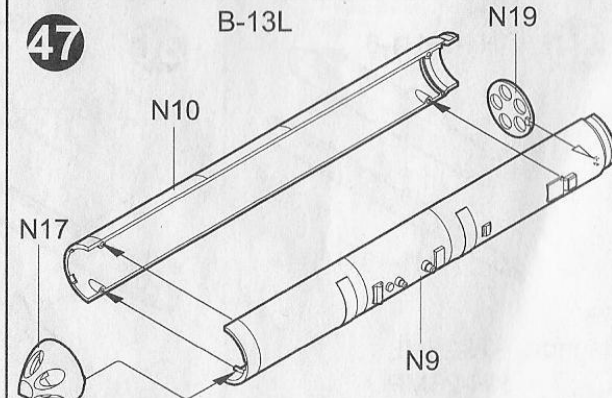

48

H1-1+H1-2

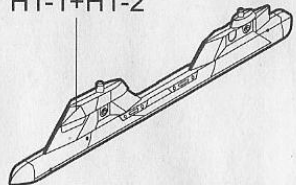

用于
Use for: R-27T
R-27R
R-27AE
R-27ER

49

R-27T

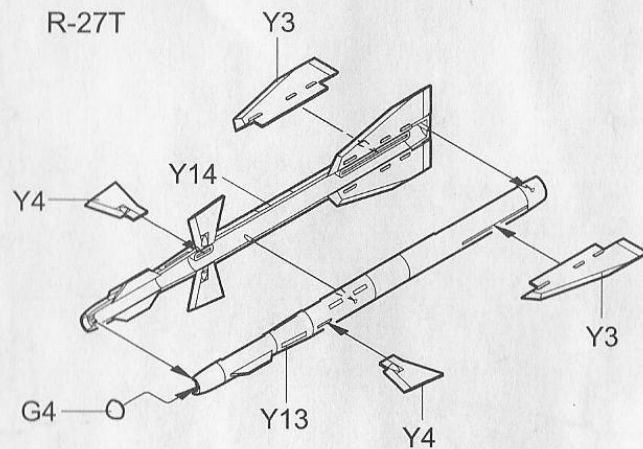

50

R-27AE

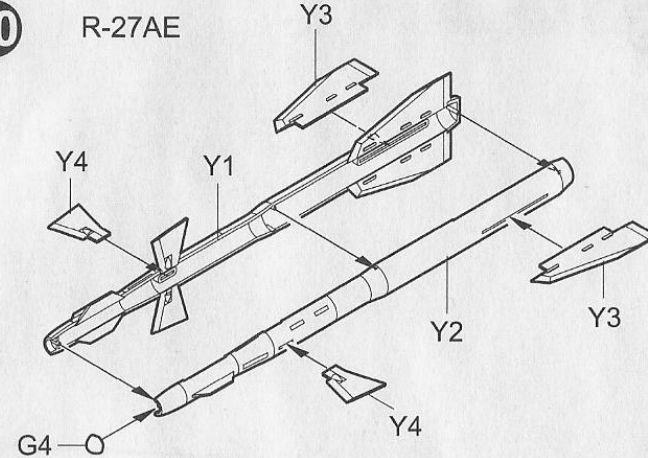

51

R-27R

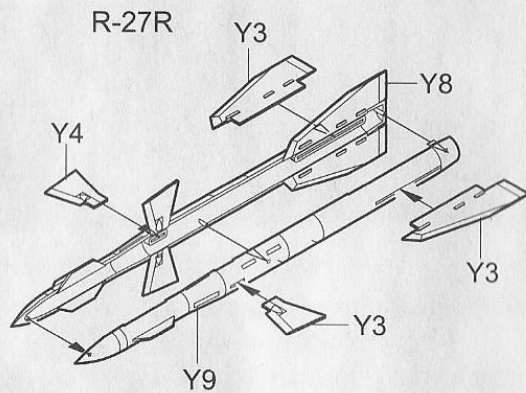

52

R-27ER

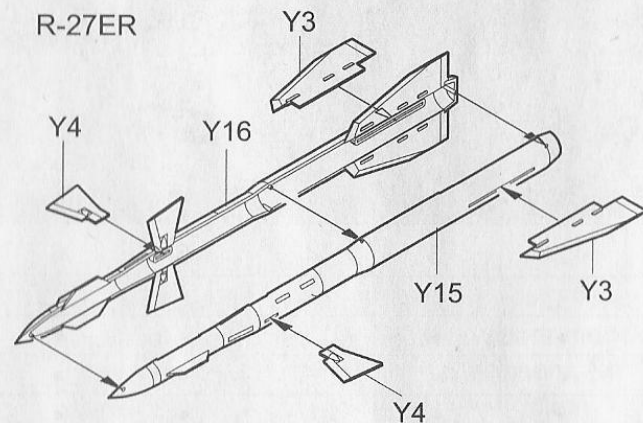

53

R-73E

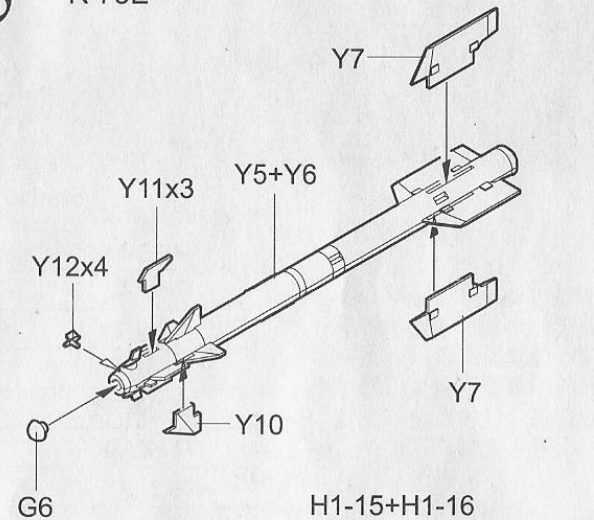

54

R-60MK

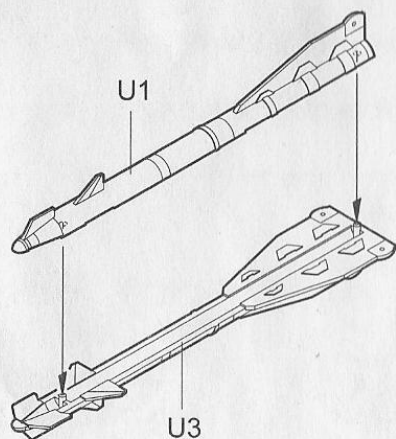

H1-9+H1-10

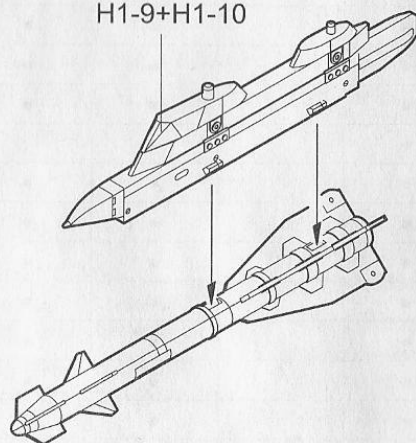

H1-15+H1-16

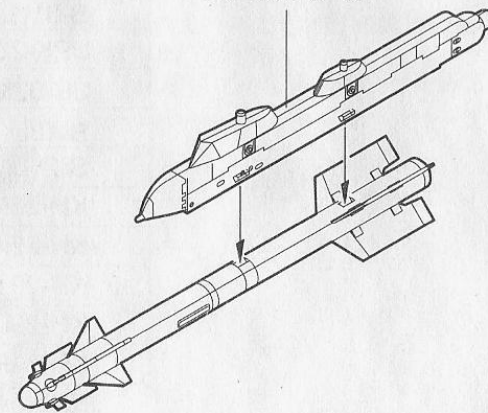

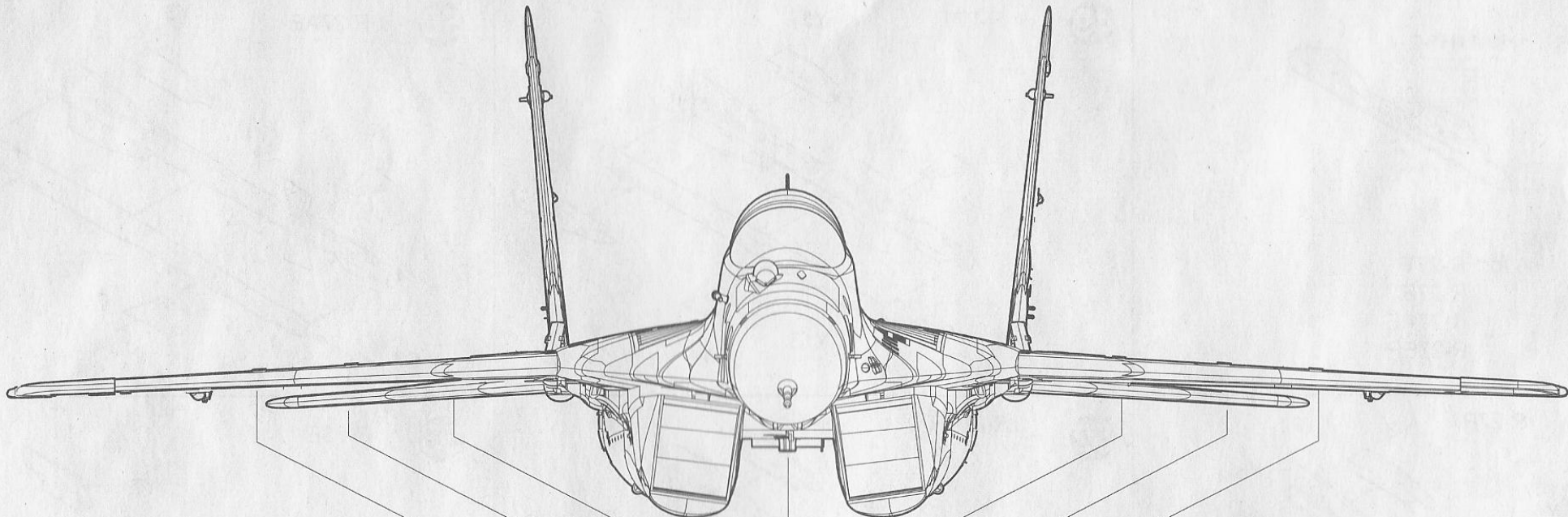

Missile/Tank	Sta.No	1	2	3	4	5	6	7
PTB-1500					•			
R-27T		•	•	•		•	•	•
R-27R		•	•	•		•	•	•
R-27AE		•	•	•		•	•	•
R-27ER		•	•	•		•	•	•
R-60MK		•	•	•		•	•	•
R-73E		•	•	•		•	•	•
B-8M1			•	•		•	•	
UPK-23/250			•	•		•	•	
UB-32M/57				•		•		
B-13L			•	•		•	•	
S-25L			•	•		•	•	
KH-25MP			•	•		•	•	
KH-25ML			•	•		•	•	
KH-29T			•	•		•	•	
KH-29L			•	•		•	•	
KH-31P			•	•		•	•	
KH-35A			•	•		•	•	