

# CANON DE 155 C MODÉLE 1917 SCHNEIDER

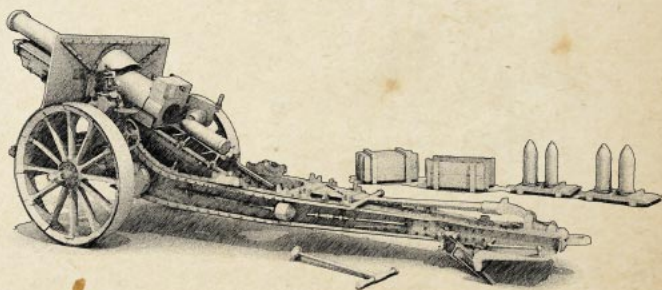

Known by many different names "Canon de 155 Mle 1917 Schneider C" (France, Belgium), "15.5cm sFH 414(f)" (German Afrikakorps), "Model 1918 155mm Howitzer" (U.S.A.) served in the armies of many nations during World War I, the Spanish Civil War, World War II, and even beyond. The last military to use the Schneider 155 was Finland, with a modified version serving in a training roll into the 1980s.

This boxing, Das Werk 35022, includes parts needed to build all WWI versions, Spanish Civil War version (which is mostly identical to the WWI version) and WWII German version. The kit can be built in the travel or battery (firing) positions, with the breech open or closed, and includes accessories that would be common in a firing position. Shells of two types, along with their crates, as well as two styles of loading rammer, and the manual shell handling cradle are also included. The shell cradle can be mounted to the chassis as might be seen in travel or in museums, or it can be placed as an accessory in a diorama (see illustration on page 3 for an example).

The U.S. Model 1918 would serve in the Pacific Theater of Operations in the early years of the war. The elements that make the U.S. version unique (pneumatic tires, flat shield, and unique rear hitch and data plaque) are included in the Das Werk 35023 boxing of the kit.

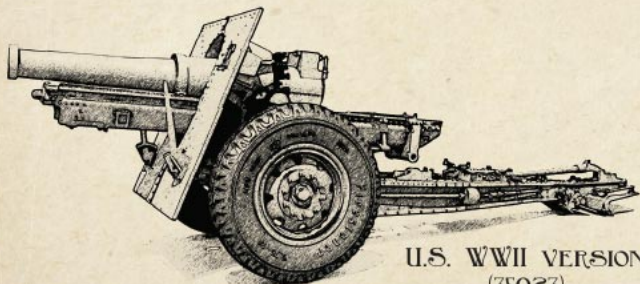

U.S. WWII VERSION  
(35023)

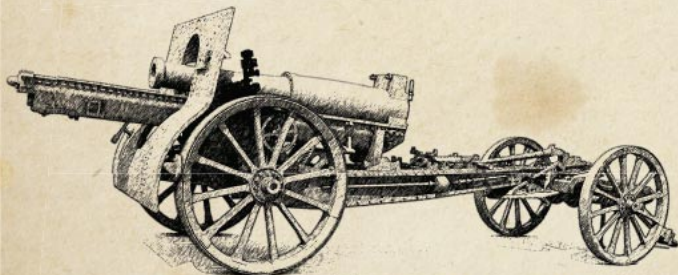

TRANSPORT MODE

## TYPICAL FIRING POSITION

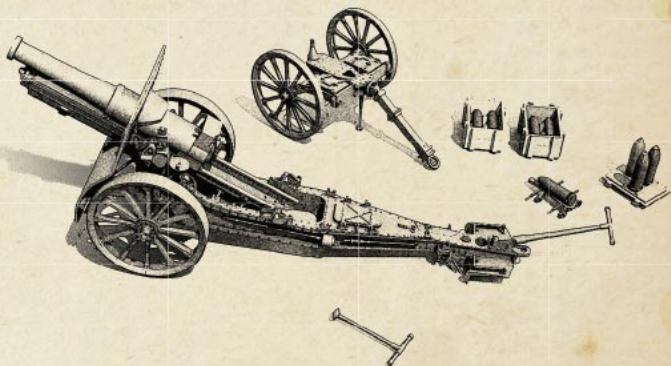

**Warning:** Choking hazard. Keep small bits and pieces away from toddlers. Use paint and glue in well-ventilated areas only, away from open flame. Wear protective gear while working with knives and while sanding. Protect your lungs from dust and fumes. Beware of sharp edges.

**Assembly:** read the instructions carefully before starting assembly. Dry-fit parts and sub-assemblies before installing them.

**Painting:** Always run a paint test bed parallel to the project. Test chemical reactions and products from different brands for compatibility before combining different products on your model. Use the test bed to experiment with weathering effects as well.

**Decals:** Soak decals in warm water until they become loosened from the carrier film. Consider using softeners and setting solutions. Avoid trapping air bubbles under the decal. Seal decals with a clear coat after they have thoroughly dried.



OPTION



CAUTION



REPEAT



DECALS



ANNEAL



USE LITTLE GLUE



USE CA GLUE



CHECK BOX



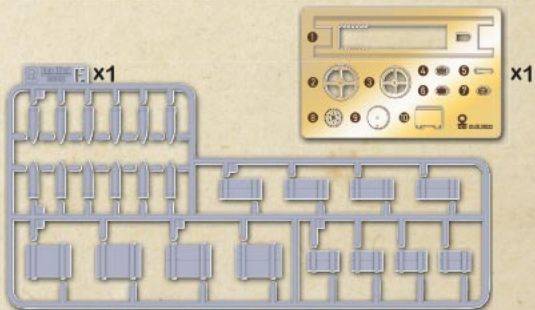
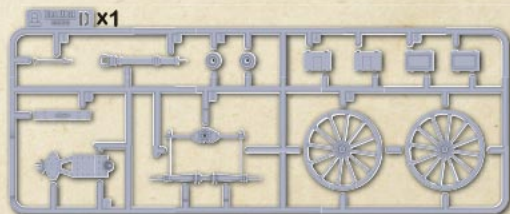
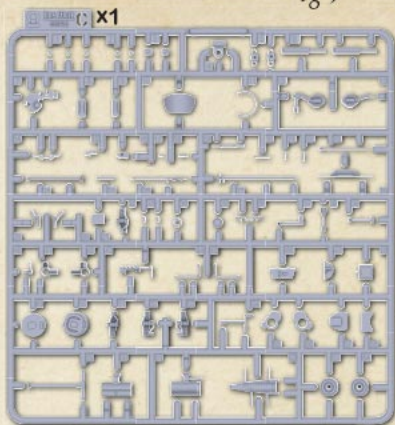





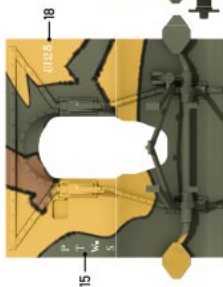
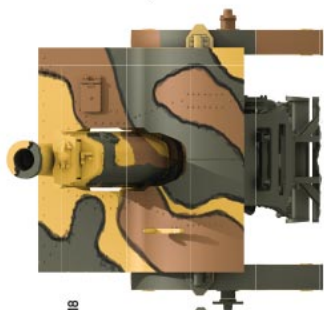

## WORLD WAR I U.S.A.

"Calamity Jane" of Battery E, 11th Field Artillery, fired the last artillery round of World War I at 1100 hrs, 11 November 1918



15

18

|   |  |         |        |        |                |
|---|--|---------|--------|--------|----------------|
|  | XF62<br>HS2<br>926<br>71316<br>86          | MMP024  | MMP033 | MMP011 | Mission Models |
|  | XF52<br>H37<br>064<br>71136<br>113         | Humbrol | 74     |        |                |
|  | XF60<br>H071<br>130<br>71031<br>74         | Vallejo |        |        |                |
|   | TAMIYA<br>Mr Hobby H Series<br>AMMO of Mig |         |        |        |                |



# SPANISH CIVIL WAR 1936–1939

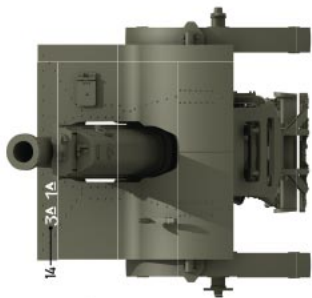

Alternate  
markings 2

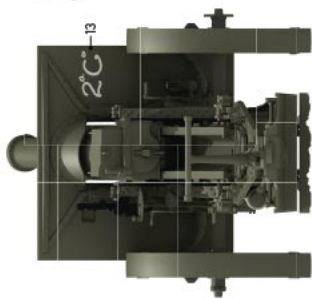

Alternate markings 1

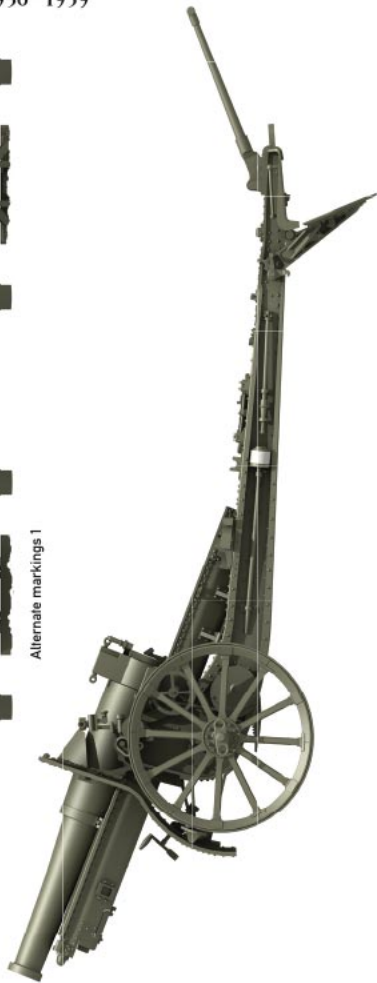

XF73  
H421  
031  
71341  
102  
MMP030

TAMIYA

Mr Hobby H Series

AMMO of Mig

Vallejo

Humbrol

Mission Models

# WORLD WAR II GERMANY – AFRIKA

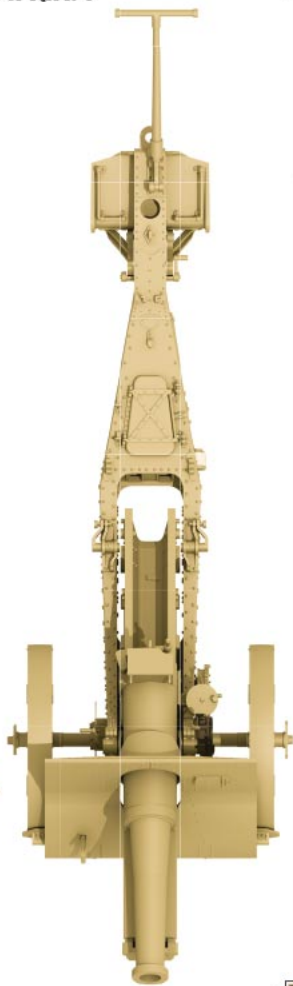

XF92 TAMIYA  
H79 Mr Hobby H Series  
012 AMMO of Mig  
71122 Vallejo  
74 Humbrol  
011 Mission Models

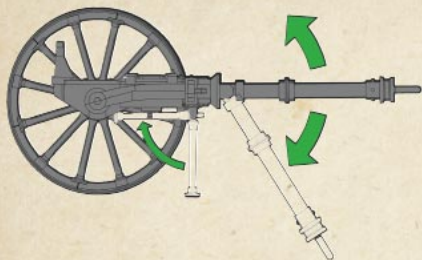

**ATTENTION!**  
ADD YOKE AND  
BOTTOM STAND  
IN DESIRED  
POSITION AFTER  
PLACING LIMBER IN  
SCENE

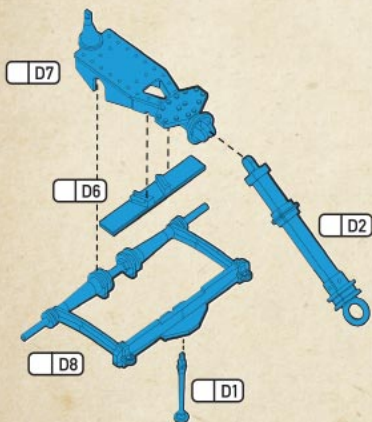

D4



D5



x 2

REPEAT

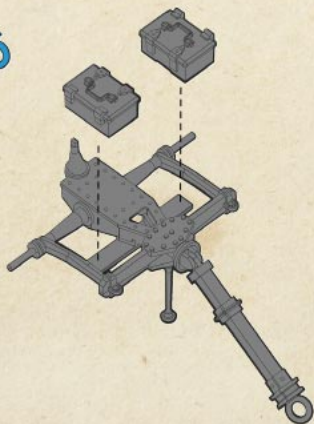

See the last step (Pg 27) for adding the  
limber to the finished model.

**x 2**  
REPEAT

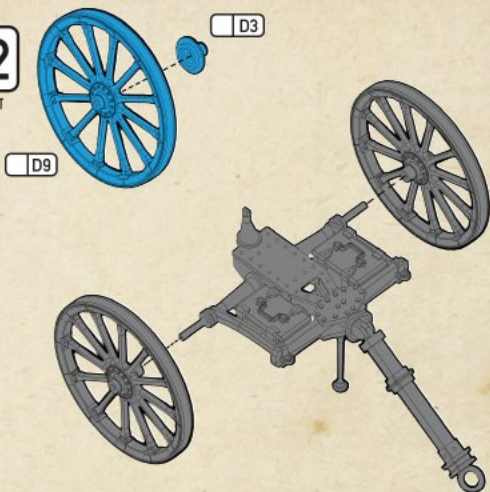

**x 2**  
REPEAT



-CRATE LIDS CAN BE LEFT OFF.  
-SHELLS CAN BE DISPLAYED OUTSIDE OF CRATE

2 TYPES OF SHELL  
ARE INCLUDED  
(colors are speculation)

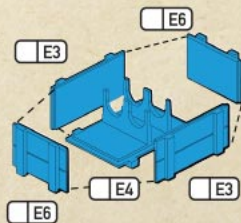

**E5**



**E1**

**E2**

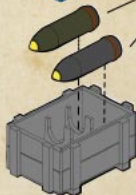

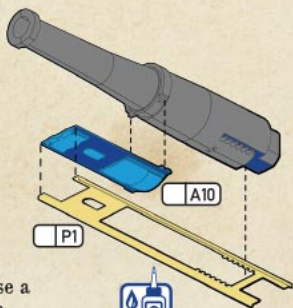
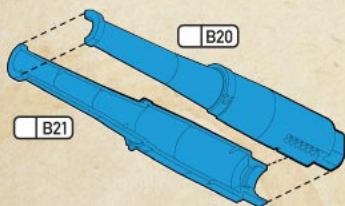
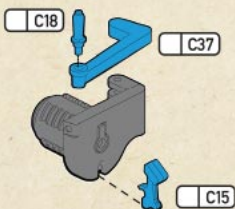
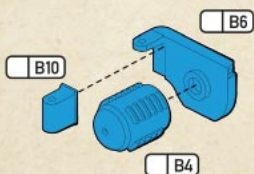
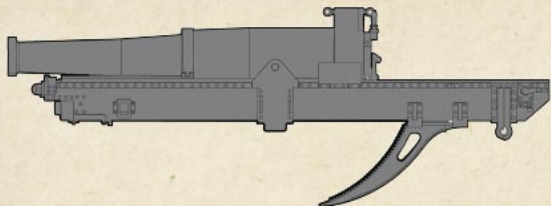

ANNEAL

Anneal part first. Work slowly, use a photoetch bending tool if possible

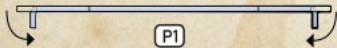

P1



USE CA  
GLUE

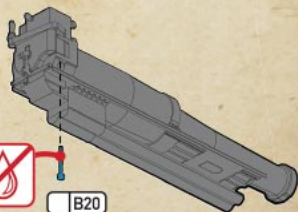
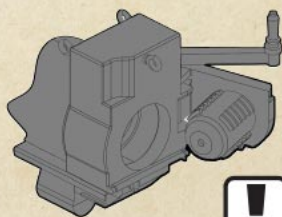
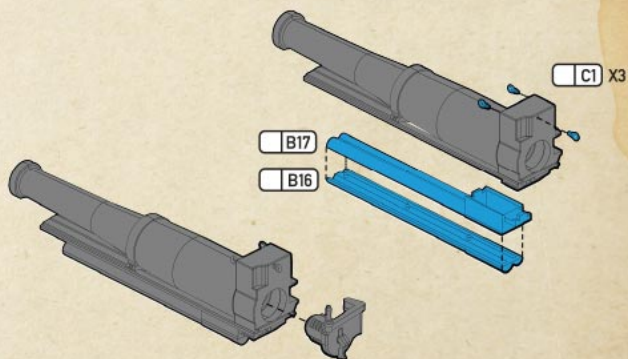
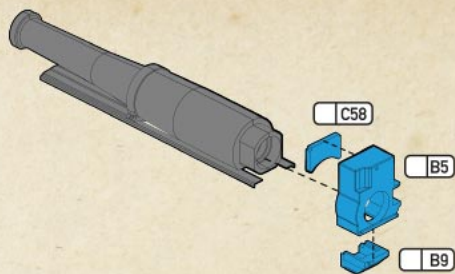

B20

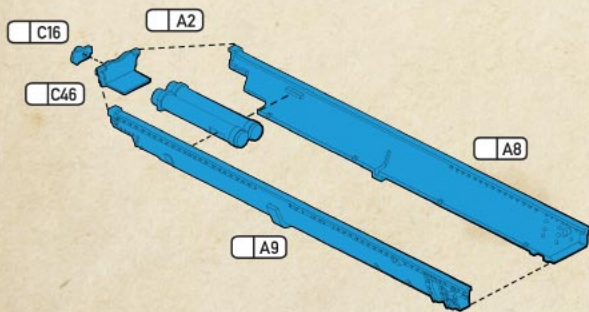
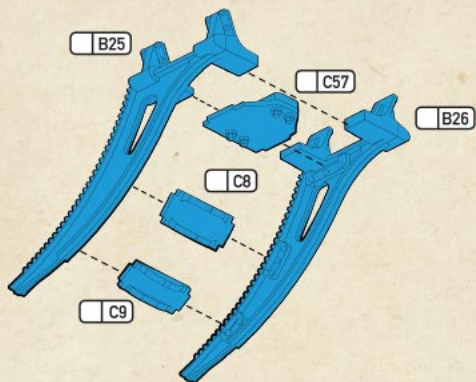

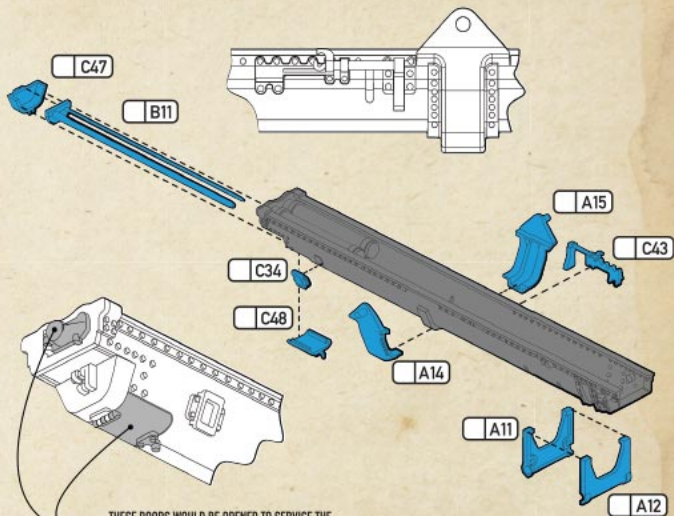

THESE DOORS WOULD BE OPENED TO SERVICE THE HYDRAULIC RECOIL CYLINDERS DURING USE AND MAINTENANCE

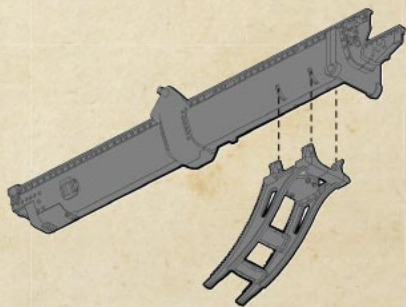



P10



USE CA GLUE

P10

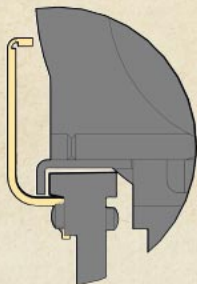
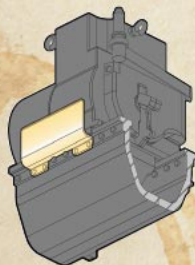

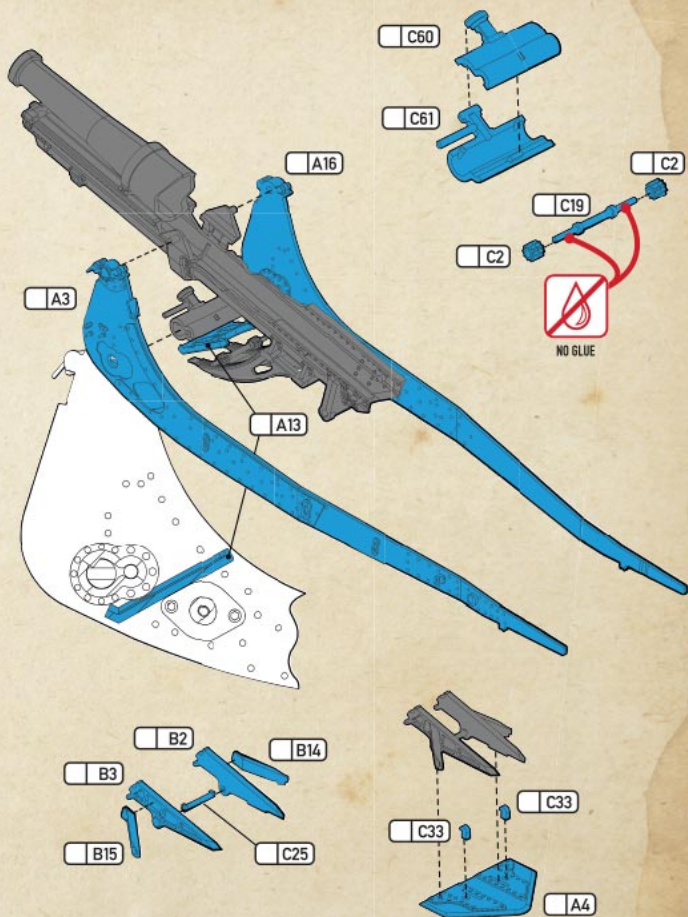

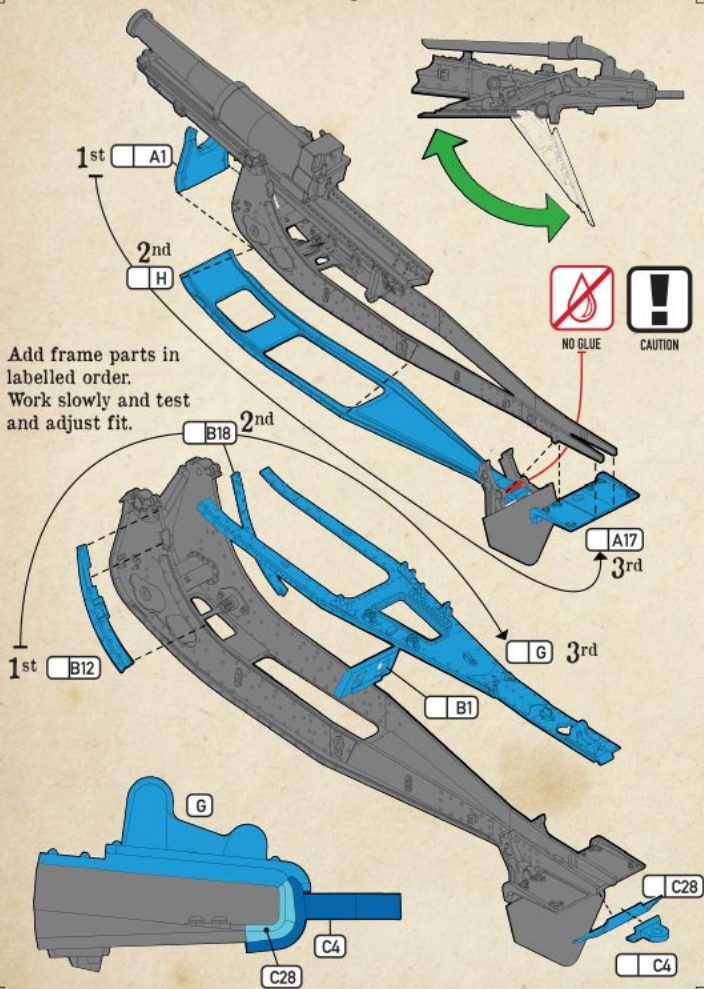

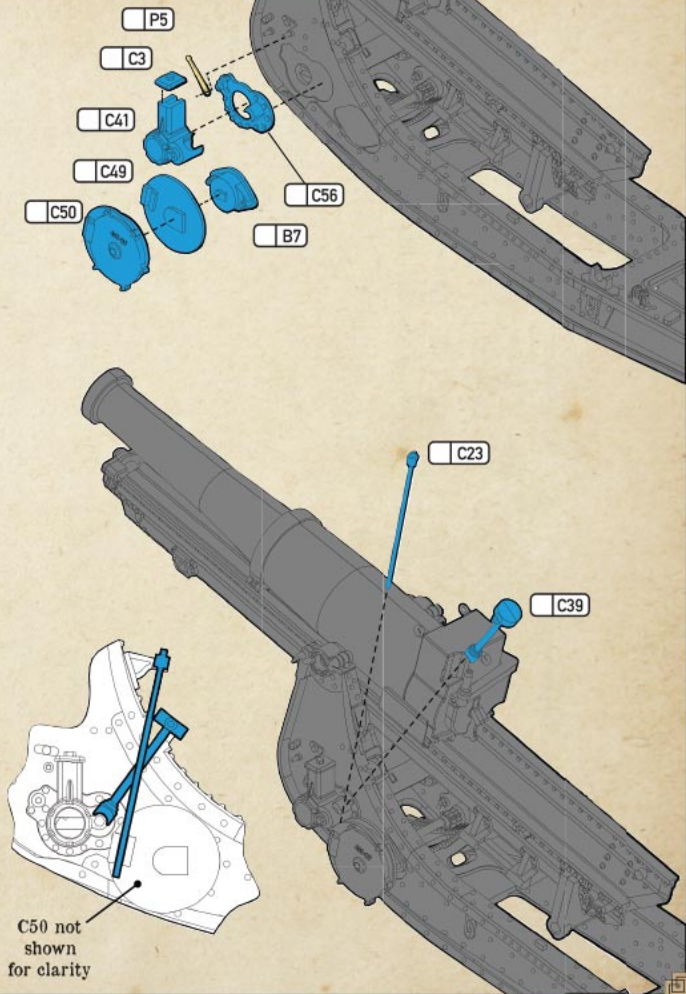

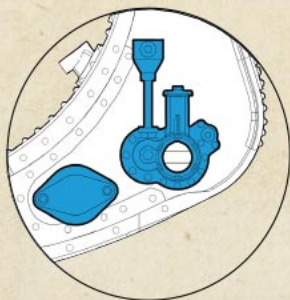
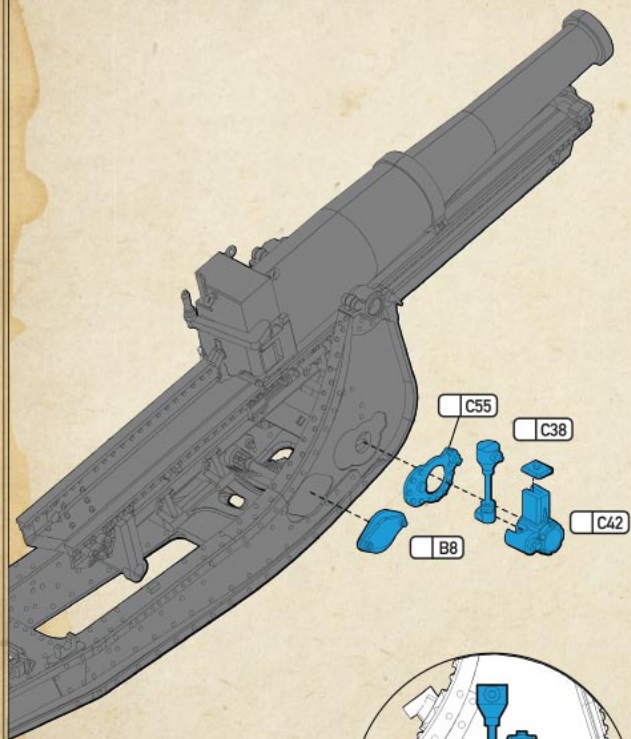



OPTION

C32

C51

C52

C53



USE CA GLUE

B19

P4

P6



SPAIN



OTHERS

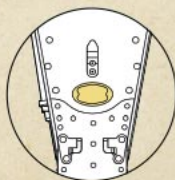

C40



CAUTION

C45

C44

B13

Gluing C40 and B13  
will permanently fix  
the rotating spade in  
place

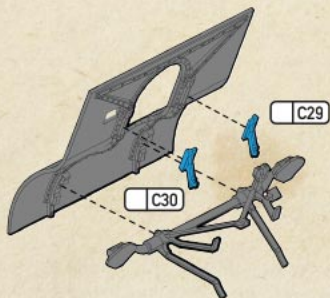
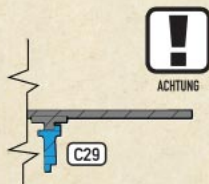
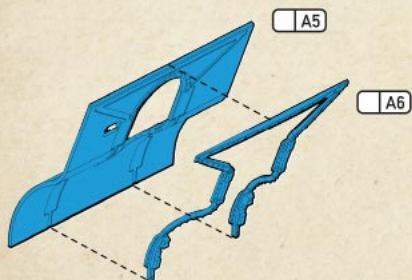

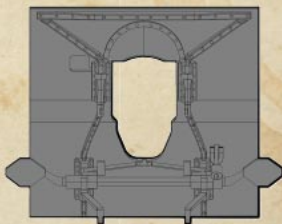
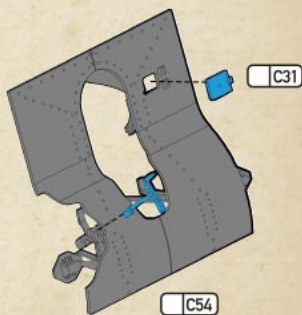
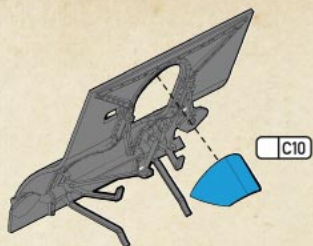

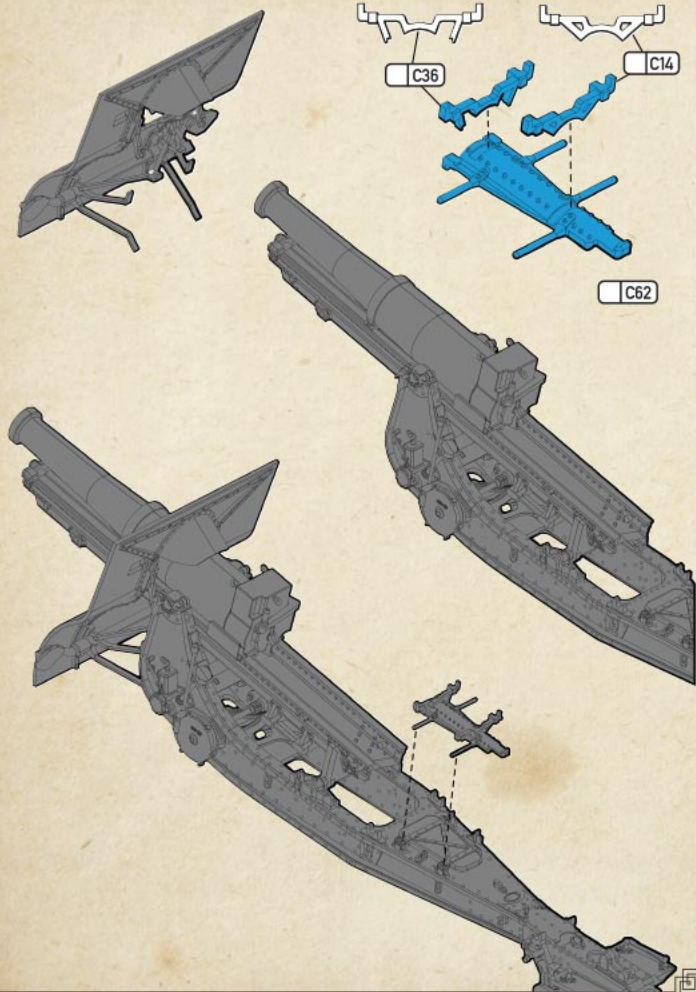

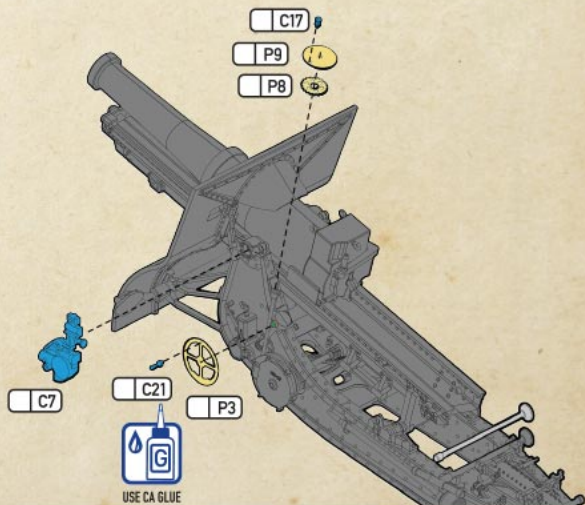
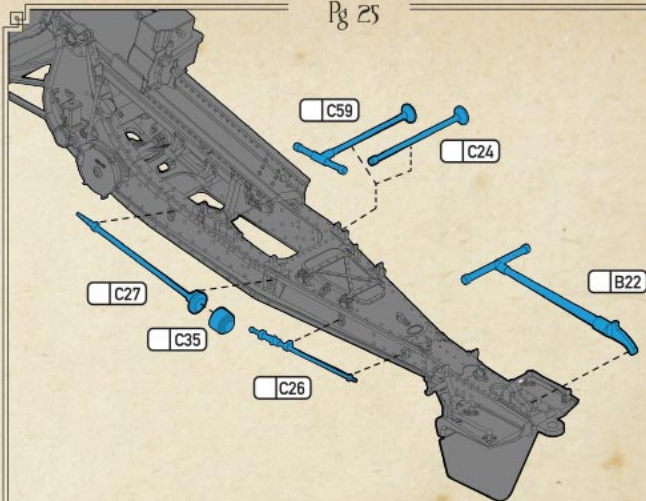

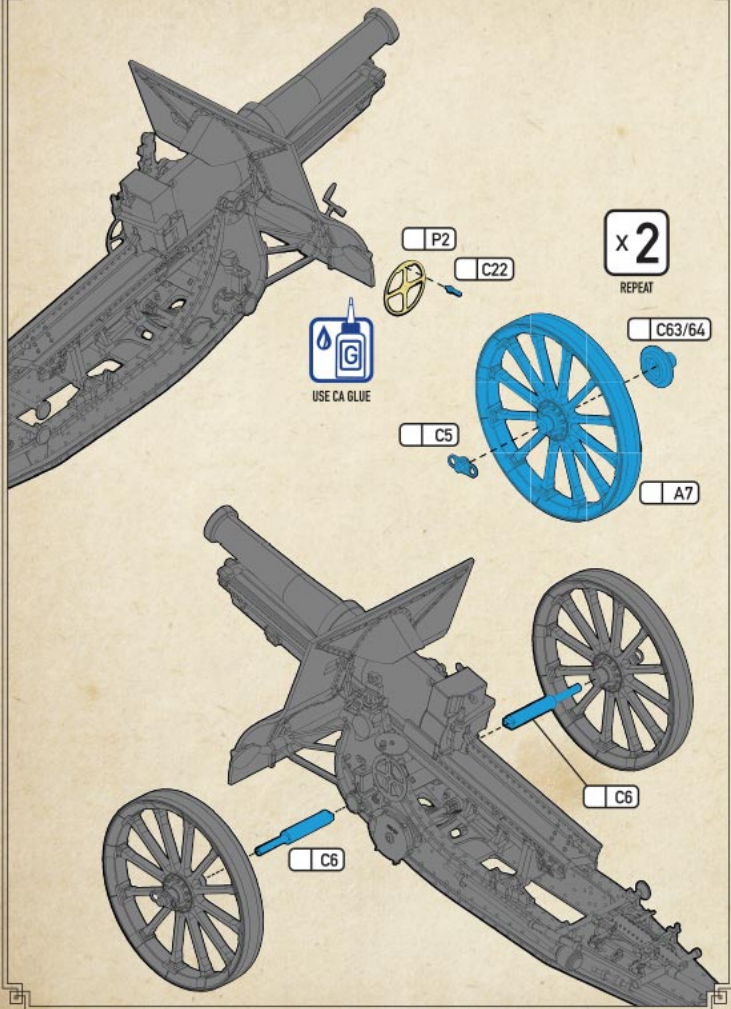

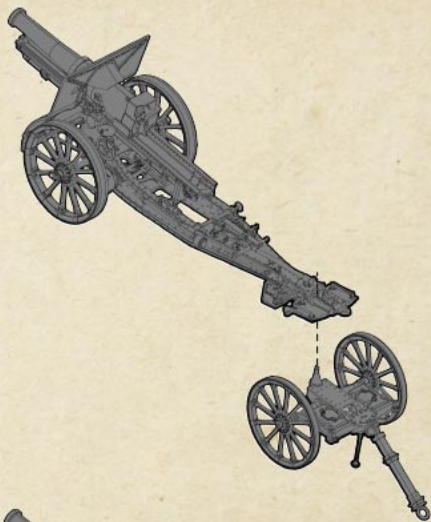



Harald Bauske ~ CEO

As the owner and managing director of Modellbau König GmbH & Co KG, Harald assembled a team of creative professionals and provided the budgets to pursue one of his dreams: releasing a plastic model kit under his own brand. Now, in late 2018, his dream has come true. Back in 1999, when he made the first steps with his company, he did not imagine that this dream would ever become a reality.



Pete Hamann ~ 3D designer, CAD modeler, Instruction manual design

Born and raised in California, Pete worked on his design chops as an aerospace designer in Seattle, Washington before packing up and relocating to Spain. He developed a deep interest in flying machines while growing up next to military air bases in Southern California. After spending a few years as a machinist, making other people's designs a reality, he obtained a bachelor of arts degree in industrial design.

Pete can be reached at [Peterjhamann@gmail.com](mailto:Peterjhamann@gmail.com)

This project would not have been possible without the help of:

Guillem Marti Pujol  
 Juanjo Lopéz  
 Chris "Toadman" Hughes

Special thanks to:  
 Rafael Paniagua (Maquetas RPM Getafe, Madrid)

A DAS WERK & Custom Scale production

2021

Modellbaukönig GmbH & Co. KG

Nordenhamer Str. 177

27751 Delmenhorst

Deutschland