

Bf 110G-4

eduard

1/48 Scale Plastic Model Kit

WEEKEND
edition



item # 8405

The Messerschmitt Bf 110 soldiered throughout the WWII as a fighter, fighter-bomber or night fighter. In the latter role, it proved its worth even at the very end of the war.

It was in 1934 when the Reich Ministry of Aviation (RLM, Reichsluftfahrtministerium) issued a request for a new twin-engine heavy fighter capable of successful dogfight with single-engine fighters. Apart of the long range and high speed the heavy armament was also to be an advantage of the new aircraft. Hermann Göring, the Reich Aviation Minister, was the "heavy weight" behind the concept and strong proponent of the new Kampferstörer (Combat Destroyer). The concept was intended to overcome troubles the designers were running into with first generation of monoplane designs as these fighters usually lacked range and power.

Thus, the RLM requested twin-engine, three-seat aircraft of all-metal design with internal bomb bay. Three manufacturers responded with their design: Focke-Wulf, Henschel and BFW (i.e., Bayerische Flugzeugwerke). The latter, which was to become Messerschmitt, defeated its opponents and was given funds to build three prototypes. Messerschmitt decided to omit the internal bomb bay in change for even more firepower than requested and this proved to be wise decision, as the ministry changed its mind (partly under pressure from Ernst Udet) about the internal bomb load.

From A to G

On May 12, 1936, Rudolf Opitz, the BFW company test pilot, flew the Bf 110 at Augsburg for the first time. It was powered by two DB 600A engines. Although the Bf 110 was not as maneuverable as desired, it was faster than requested and even faster than Bf 109B-1 single seat fighter. Thanks to it the order for four pre-production Bf 110A-0 units was placed with first of them delivered in January 1937 and after comparison with Fw 57 and Hs 124 competitors it was ordered for serial production.

Due to the troubles with the DB 600 engine supplies, the Jumo 210B units had to be installed into early Bf 110s, leaving them underpowered with top speed just 268 mph (431 km/h). More to it, the armament was limited to four MG 17 7.92 mm machine guns in the nose. The more powerful Jumo 210G developing 515 kW (44 kW more to 210B unit) was used for the Bf 110B with three versions. The B-1 was first to finally get two 20 mm MG FF cannons, while B-2 was reconnaissance version fitted with camera and the B-3 was used as a trainer.

Just 45 of all Bf 110Bs were manufactured as the design team reworked the engine nacelles to adapt DB 601B-1 engines, as they became available in late 1938. The top speed improved to 336 mph (541 km/h) with the resulting Bf 110C version.

With the Bf 110D the designers concentrated on range increase. The D-1 thus got the 277 gal (1,050 l) conformal tank under the belly of the fuselage with large cover. Also, two 238 gal (900 l) external drop underwing tanks were adopted, increasing the total fuel capacity to 1,088 gal (4,120 l). But the added drag of the early "dachshund's" belly was too high to allow serial production. The big tank was only used after the improvement of the shape as Bf 110D-1/R1 whereas the D-1/R2 was equipped with two drop tanks. Later D-2 and D-3 versions retained the twin underwing 900 l drop tank capability, using multipurpose ordnance racks capable of holding either drop tanks or bombs. The

development then proceeded with the fighter-bomber E version and Bf 110F, which featured new DB 601F engines capable to deliver 1,350 PS (993 kW). More power allowed armor upgrade and strengthening the airframe without performance loss. The E version was considered best among all the Bf 110s. It was fully aerobatic and responsive, although not as fast as the Bf 109. Eventually 512 Bf 110F models were completed between December 1941 and December 1942 including the first night fighter, the Bf 110F-4.

In combat

The Bf 110s served with considerable success during early campaigns of WWII until the Battle of Britain, where all its shortcomings became apparent when facing Hurricanes and Spitfires. The main weakness of the Bf 110 was its worse maneuverability, which was fully exploited by the RAF fighters. High losses of the Bf 110s during their day escort sorties forced Luftwaffe to change the tactics and scenarios when using this aircraft. Apart of this letdown, there were still tasks in which the Bf 110 would serve well when deployed properly. It was used as an air superiority fighter and fighter-bomber in Africa, Balkan, Mediterranean and on Eastern Front. It also developed into formidable night fighter with the onboard radar for searching the enemy bombers. Most of the German night fighter aces flew Bf 110s for at least part of their career.

Early variants of Bf 110 were armed with two MG FF 20 mm cannons and four 7.92 mm (.312 in) MG 17 machine guns in the nose, while single 7.92 mm (.312 in) MG 15 machine gun was rear firing for self-defensive fire. Later variants would replace the MG FFs with 15 mm MG 151s and the rear gunner's station would be armed with the twin-barreled MG 81Z (7.92 mm). Some Bf 110Gs got the 30 mm Mk 108 cannons instead of MG 17s.

This kit: Bf 110G-4

The Bf 110F version would probably have been the last evolutionary stage of a design which was getting obsolete at the time, if the successor, the Me 210, had been successful. But the opposite was true. The Me 210 was a disappointment and so development of the Bf 110 continued. The new version, designated G, received DB 605B engines of up to 1,475 HP (1,085 kW) of power. It also sported upgraded armament and underwent some aerodynamic changes. A number of field conversion kits (Rüstsätze) were developed, making the G version the most versatile of all the Bf 110s. The most numerous of all the subversions was the three-seat Bf 110G-4 night fighter equipped with the FuG 202/220 Lichtenstein radar combined in some cases with the upward-firing Schräge Music cannons. Usually these were two 20 mm MG FF guns, but MG 151/20 field installations of the same caliber or 30 mm MK 108 guns were also used. The Bf 110G-2/R1 could even use a 37 mm BK 3.7 Bordkanone gun mounted in a conformal pod under fuselage. There were a number of combinations of radar antennae, Schräge Music arrangements and other technical improvements due to the aforementioned Rüstsätze as well as Umrüst-Bausätze kits and improvements. There were 2,293 of Bf 110G built between December 1942 and April 1945.

ATTENTION



UPOZORNĚNÍ



ACHTUNG



ATTENTION



注意



Carefully read instruction sheet before assembling. When you use glue or paint, do not use near open flame and use in well ventilated room. Keep out of reach of small children. Children must not be allowed to suck any part, or pull vinyl bag over the head.



Před započítím stavby si pečlivě prostudujte stavební návod. Při používání barev a lepidel pracujte v dobře větrané místnosti. Lepidla ani barvy nepoužívejte v blízkosti otevřeného ohně. Model není určen malým dětem, mohlo by dojít k požití drobných dílů.

INSTRUCTION SIGNS

* INSTR. SYMBOLS

* INSTRUKTION SINNBILDEN

* SYMBOLES

* 記号の説明

OPTIONAL
VOLBABEND
OHNOUTSAND
BROUSITOPEN HOLE
VYVRTAT OTVORSYMETRICAL ASSEMBLY
SYMETRICKÁ MONTÁŽREMOVE
ODŘÍZNOUTREVERSE SIDE
OTOČITAPPLY EDUARD MASK
AND PAINT
POUŽÍT EDUARD MASK
NABARVIT

PLEASE CHECK THE LATEST VERSION OF THE INSTRUCTIONS ON www.eduard.com

PARTS



DÍLY



TEILE



PIÈCES



部品

C>

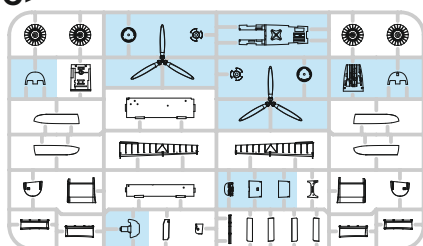

D>

PLASTIC PARTS

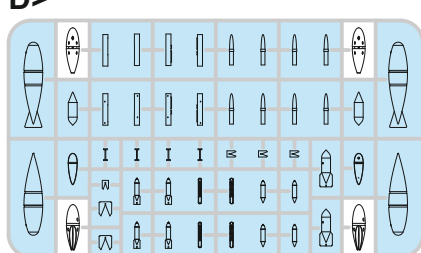

G>

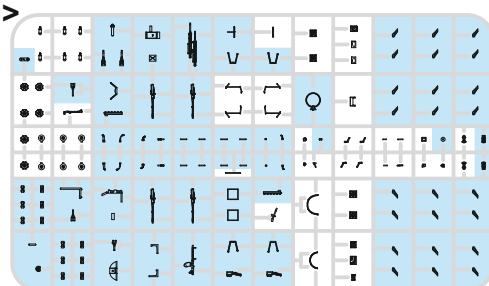

F>

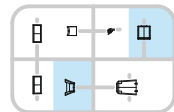

U>



J>

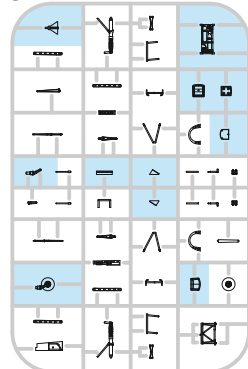

N>

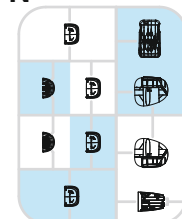

R>

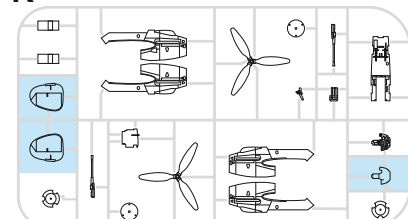

S>

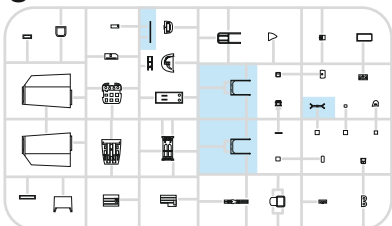

T>

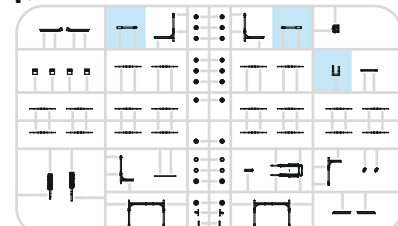

V>

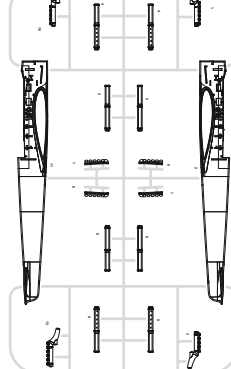

W>

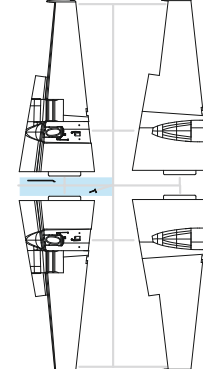

-Parts not for use. -Teile werden nicht verwendet. -Pièces à ne pas utiliser. -Tyto díly nepoužívejte při stavbě. - 使用しない部品

COLOURS



BARVY



FARBEN



PEINTURE



色

GSI Creos (GUNZE)		
AQUEOUS	Mr.COLOR	
H2	C2	BLACK
H7	C7	BROWN
H11	C61	WHITE
H12	C33	FLAT BLACK
H37	C43	WOOD BROWN
H51	C11	LIGHT GULL GREY
H64	C17	RLM71 DARK GREEN
H65	C18	RLM70 BLACK GREEN
H68	C36	RLM74 DARK GRAY
H69	C37	RLM75 GRAY
H70	C60	RLM02 GRAY
H77	C137	TIRE BLACK

AQUEOUS	Mr.COLOR	
H85	C45	SAIL COLOR
H413	C113	RLM04 YELLOW
H414	C114	RLM23 RED
H416	C116	RLM66 BLACK GRAY
H417	C417	RLM76 LIGHT BLUE
Mr.METAL COLOR		
MC213		STEEL
MC214		DARK IRON
Mr.COLOR SUPER METALLIC		
SM201		SUPER FINE SILVER
Mr.COLOR GX		
GX5		SUSIE BLUE

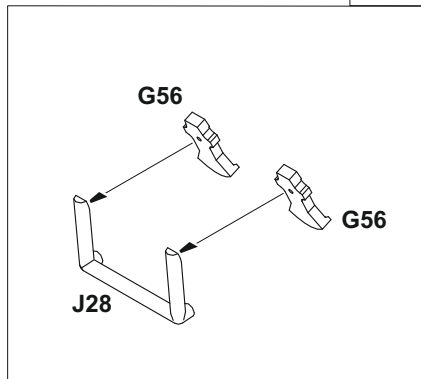
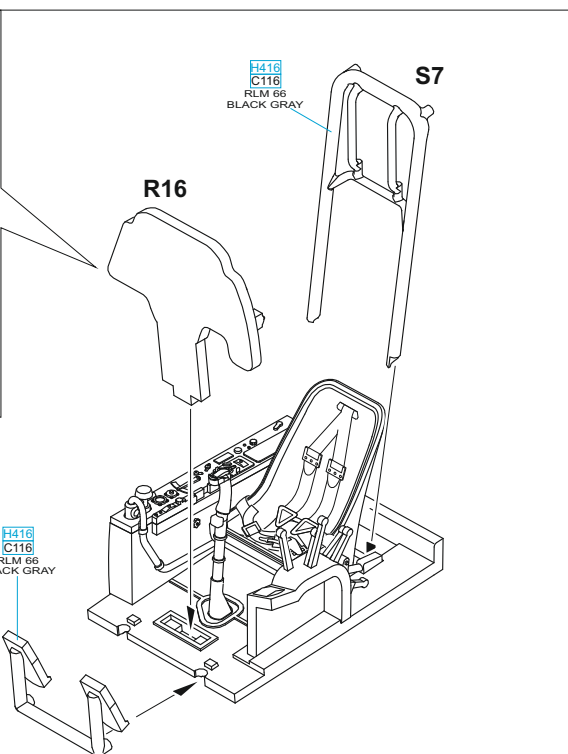
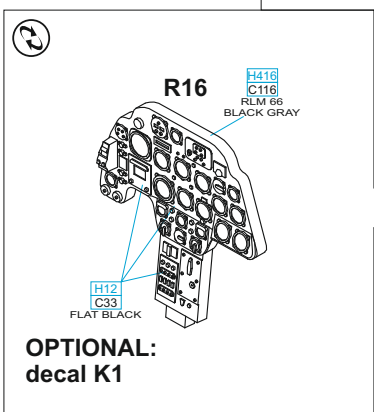
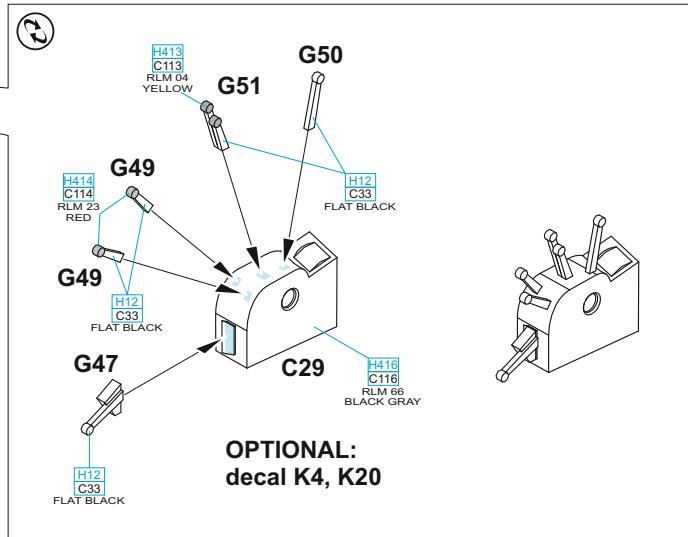
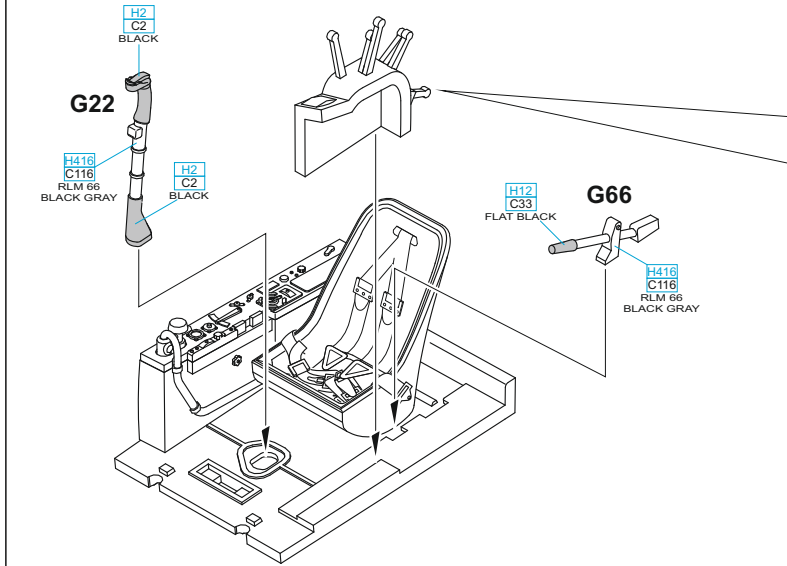
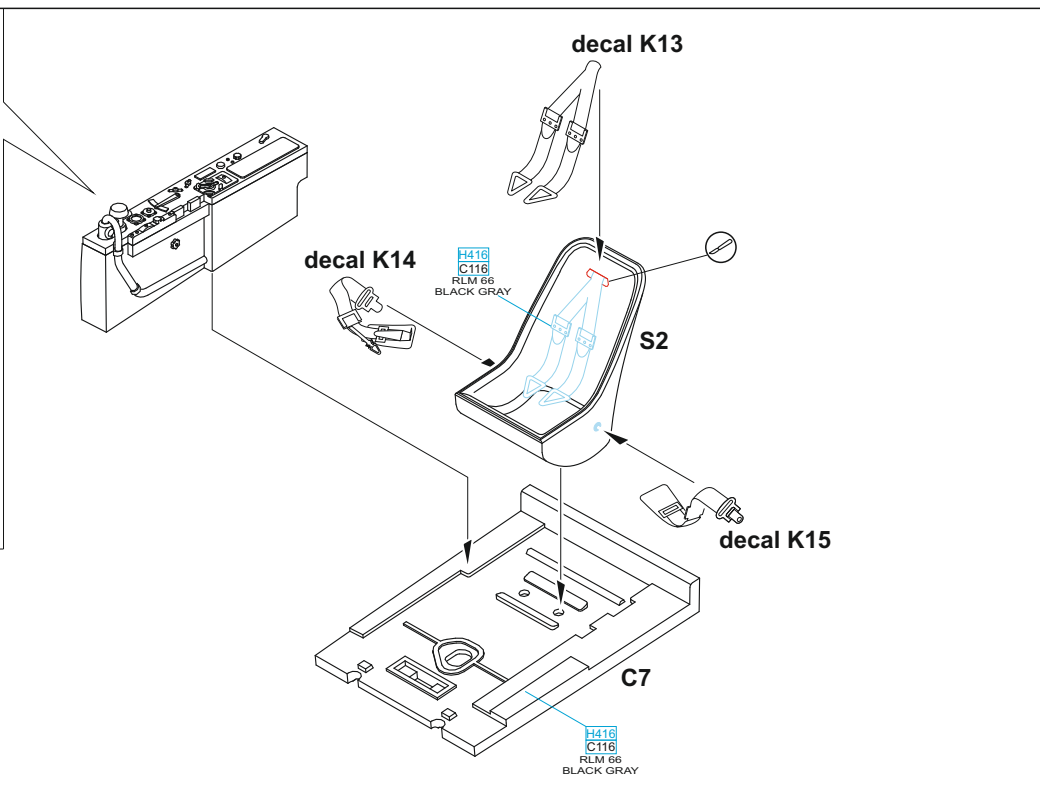
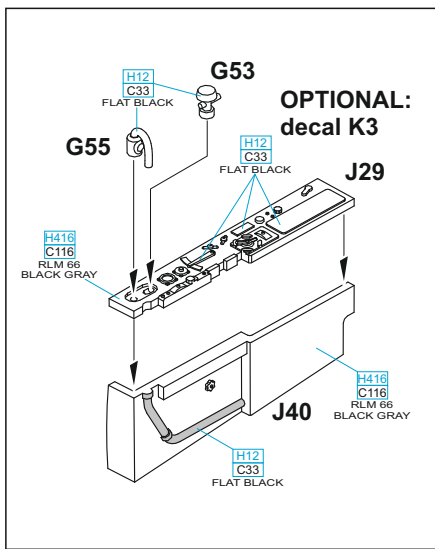

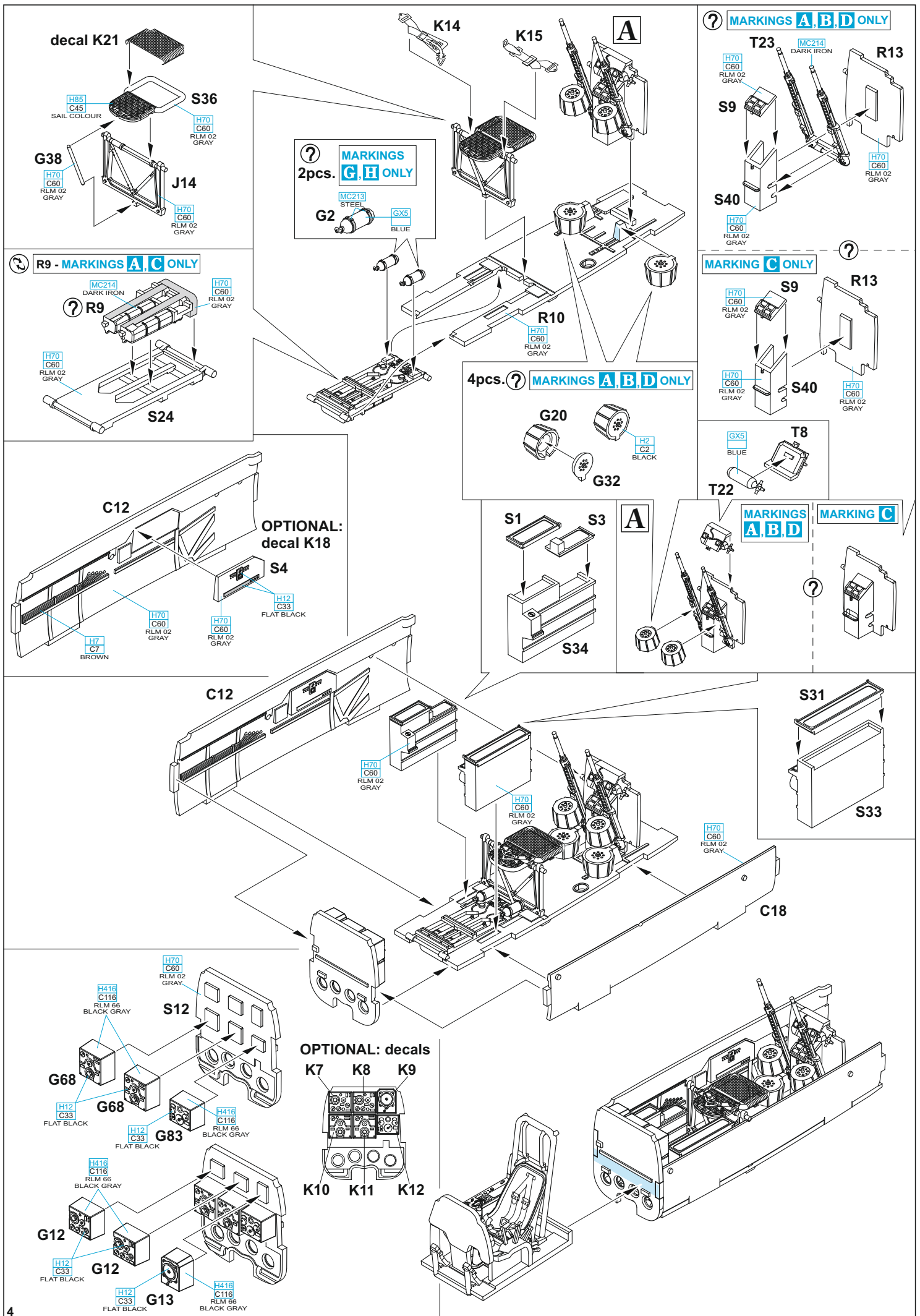

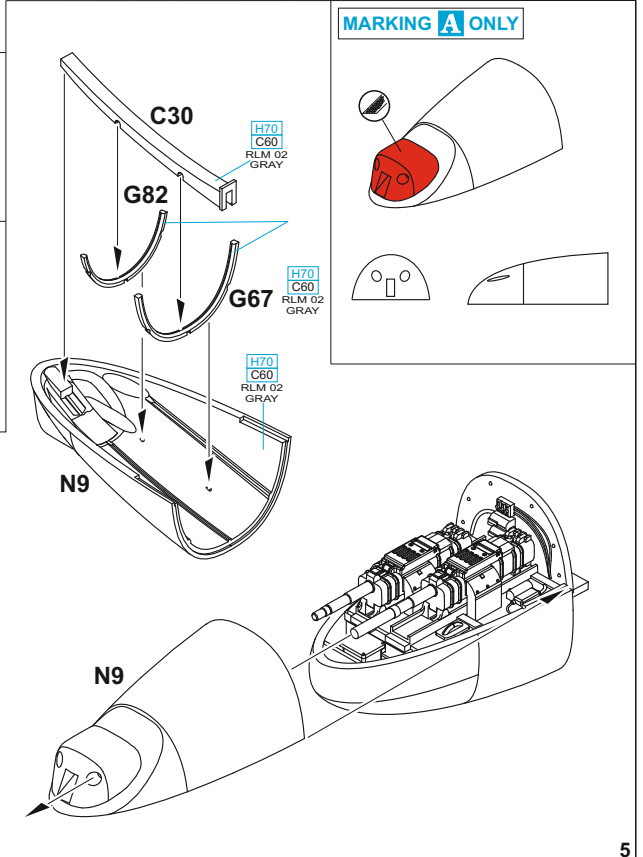
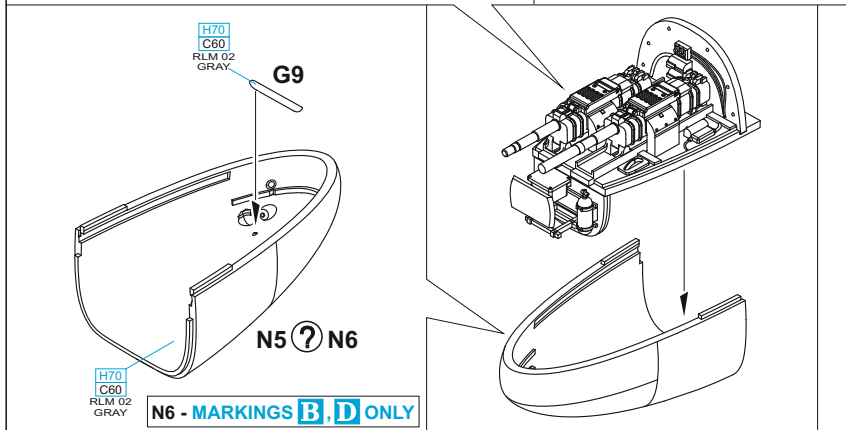
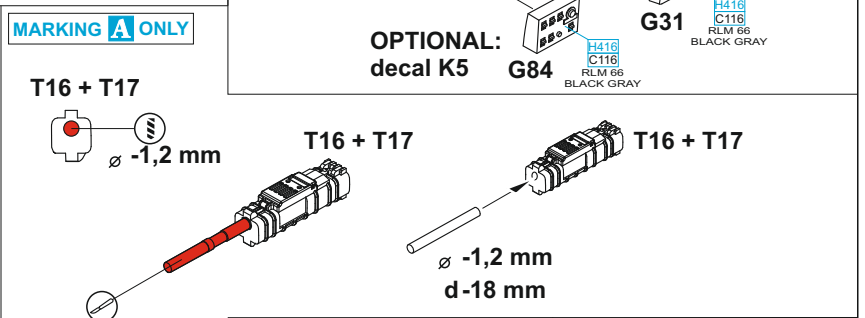
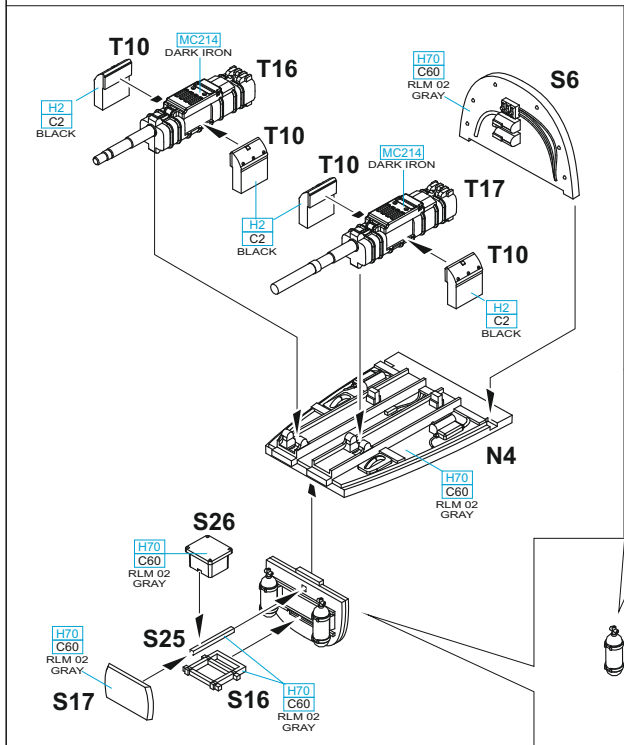
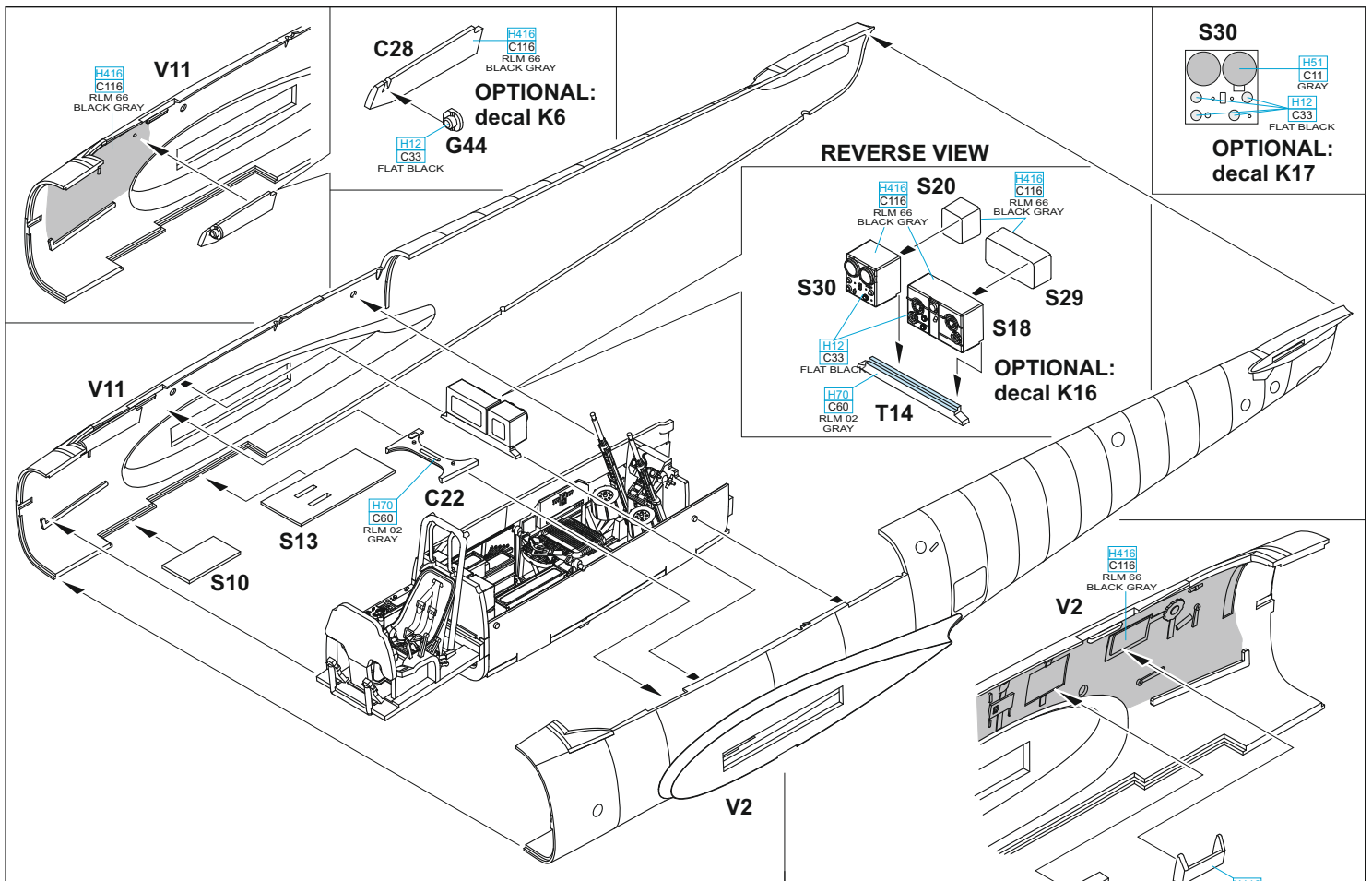

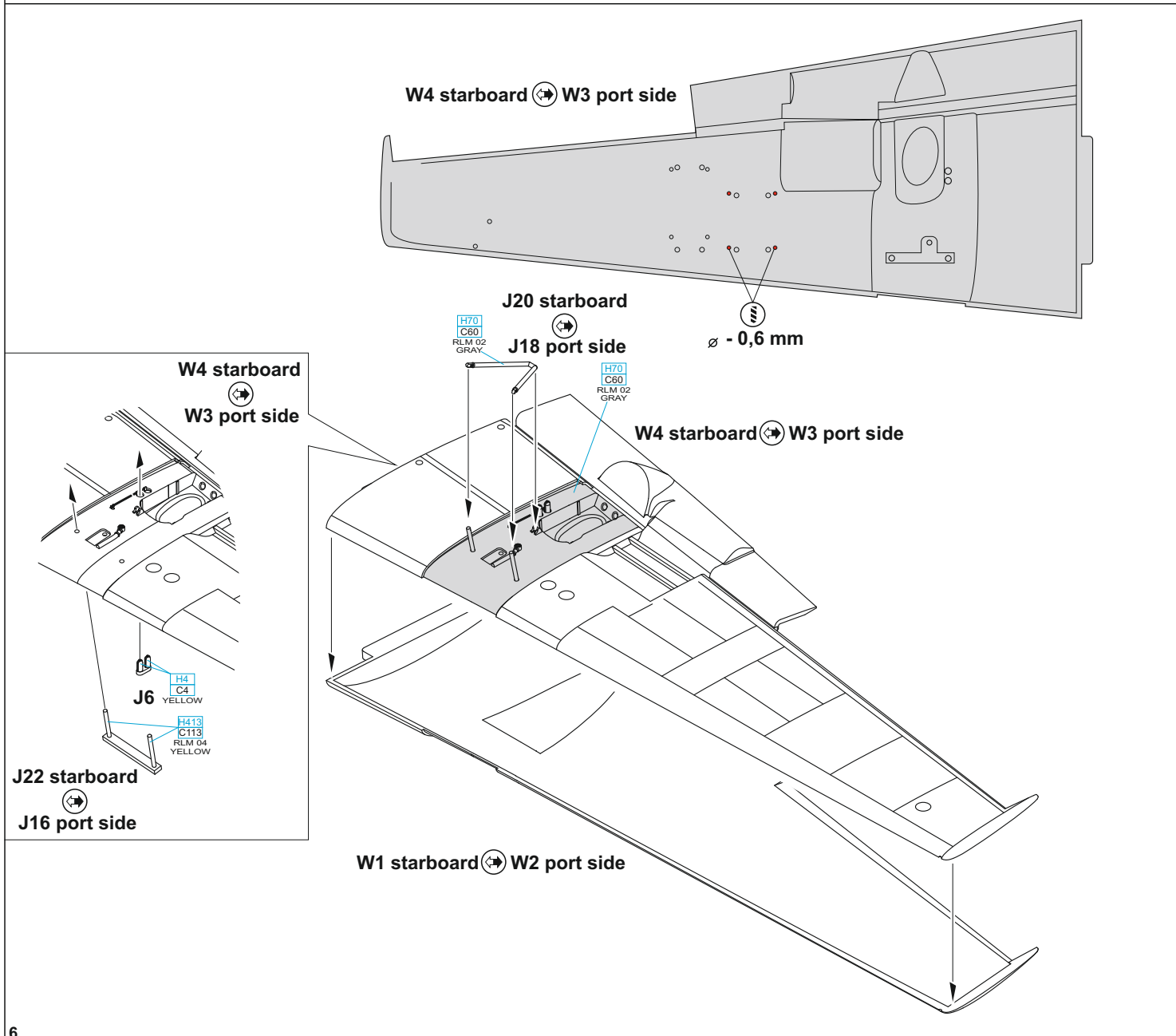
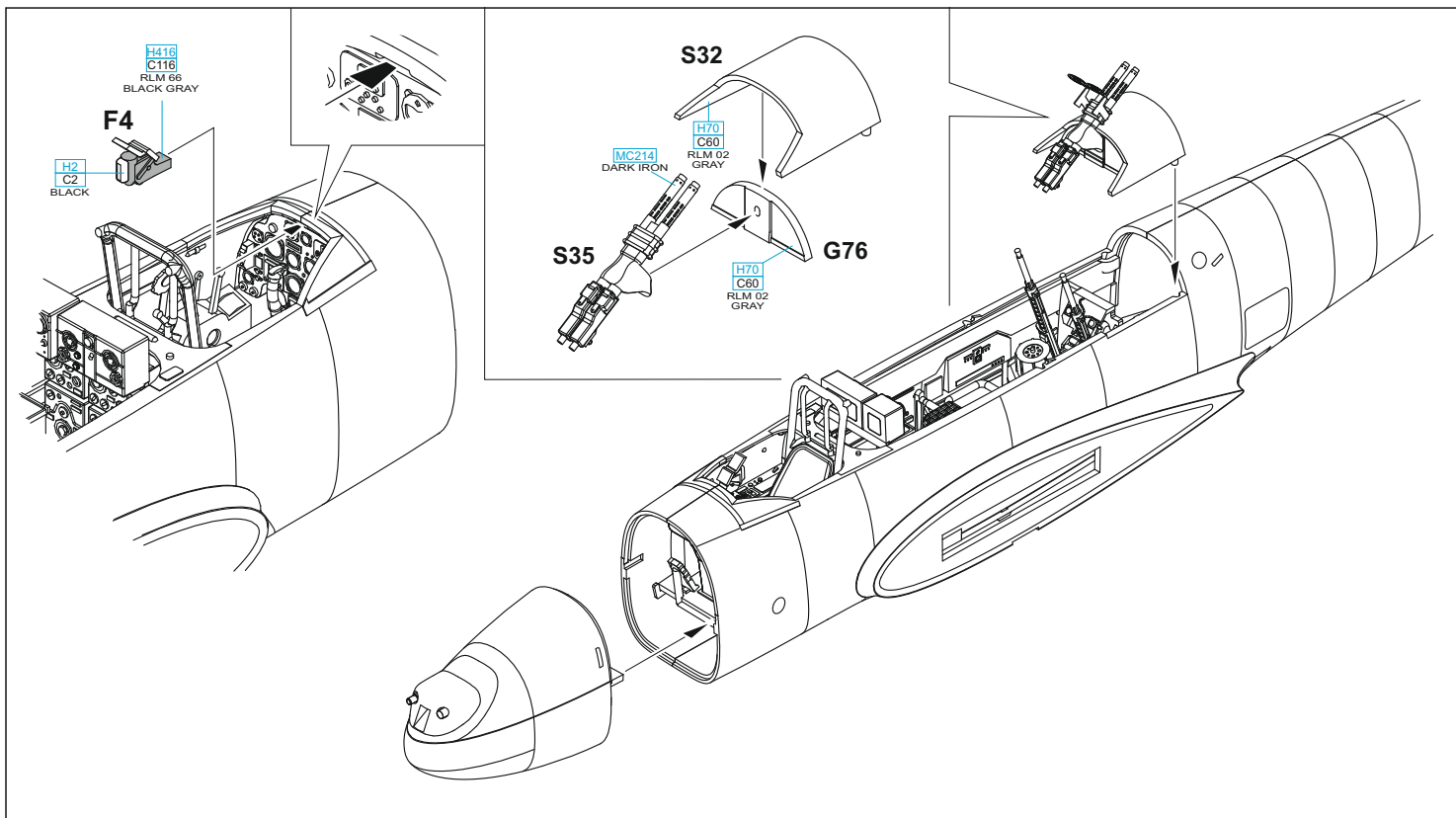

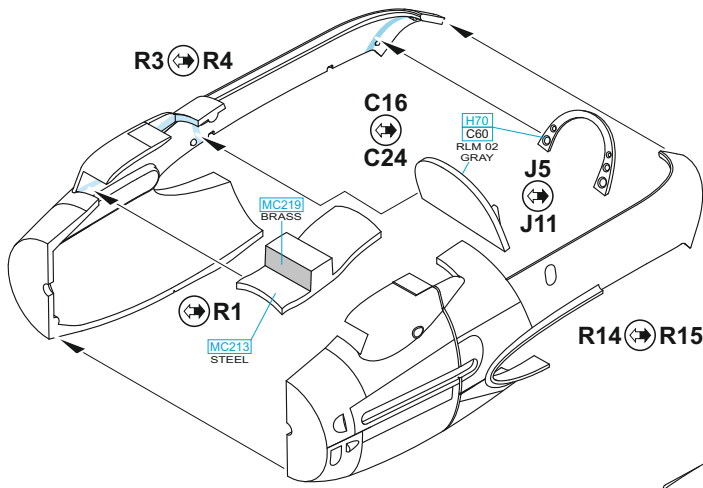

starboard - R3, R14, C16, J5
port side - R4, R15, C24, J11

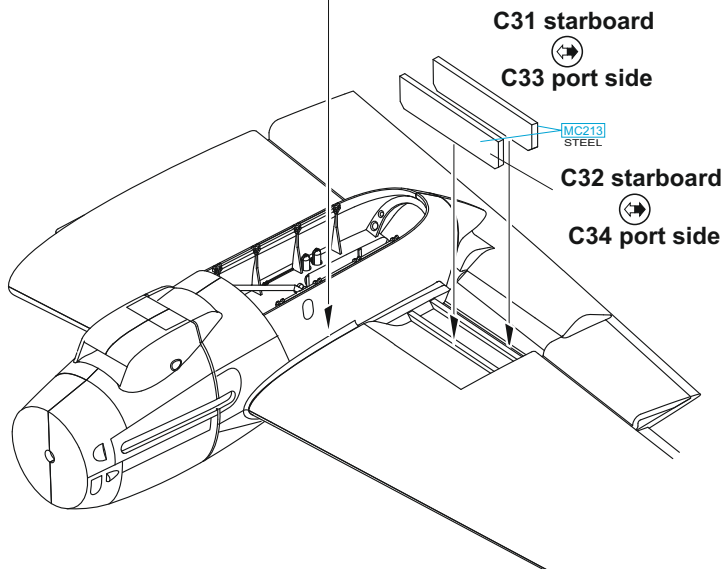
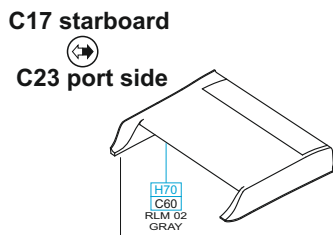
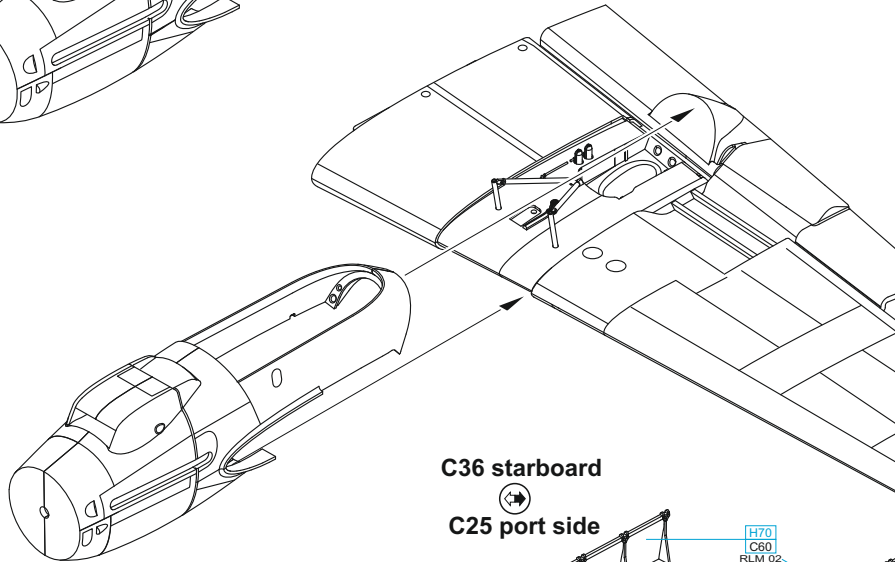

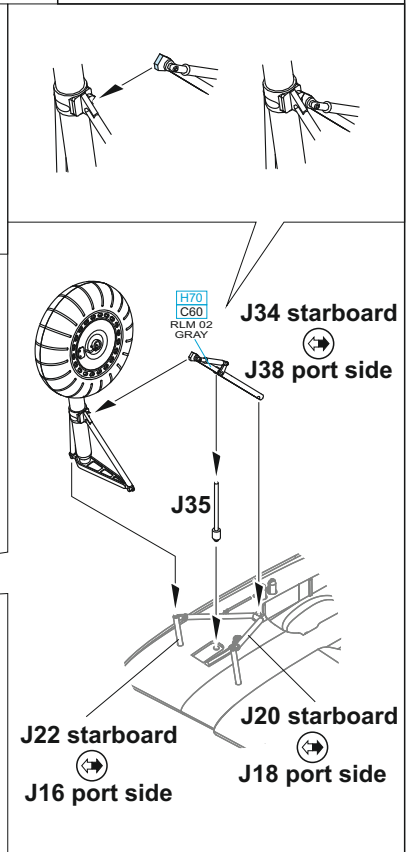
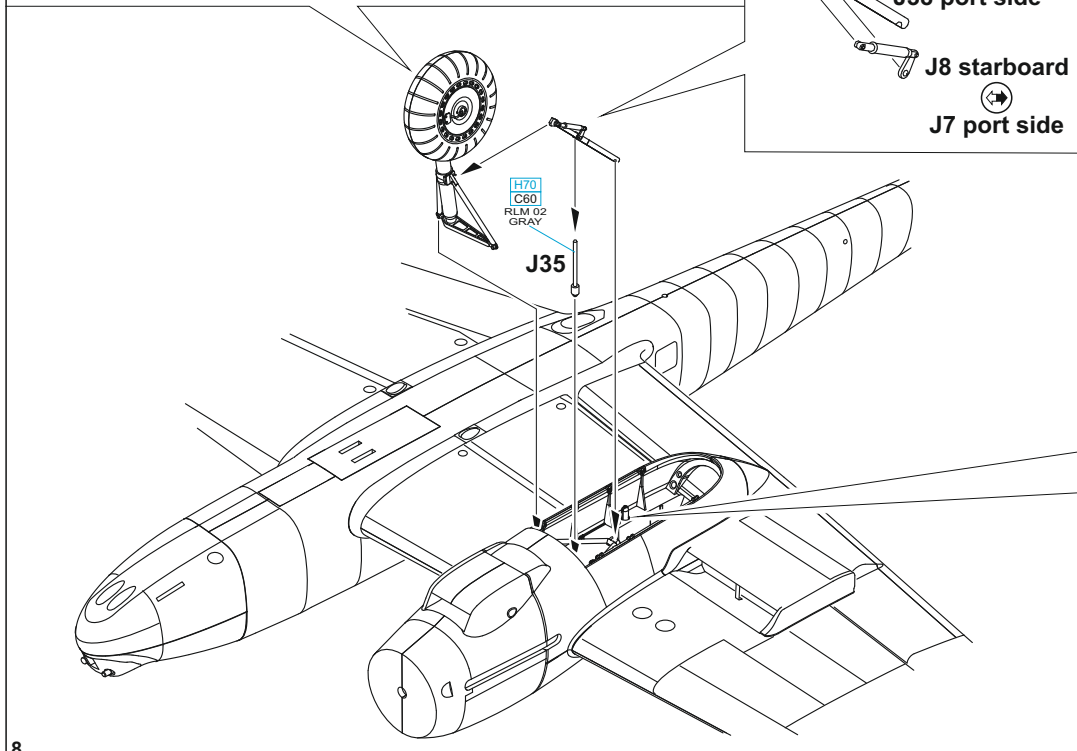
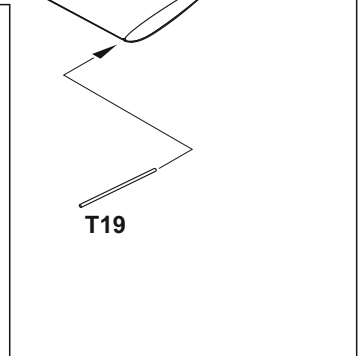
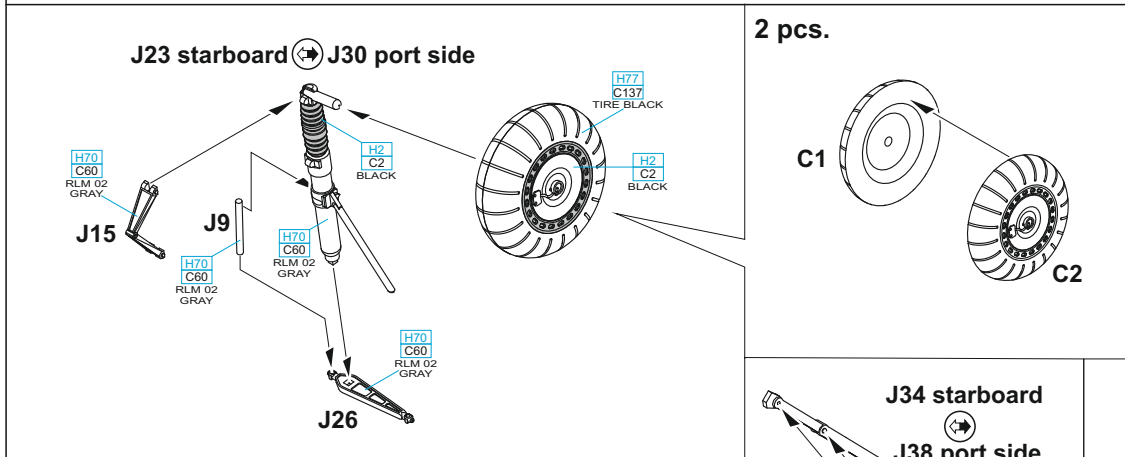
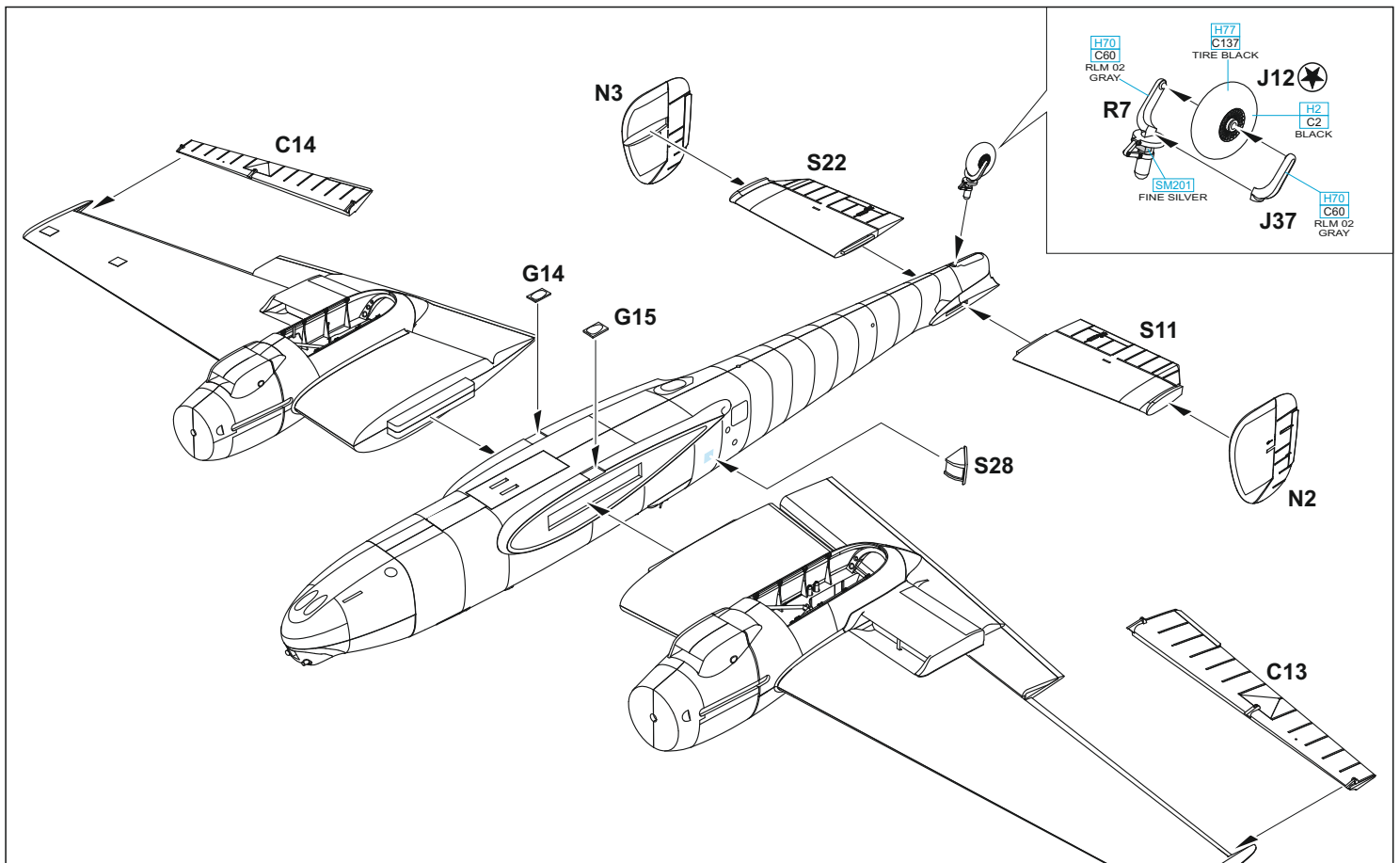

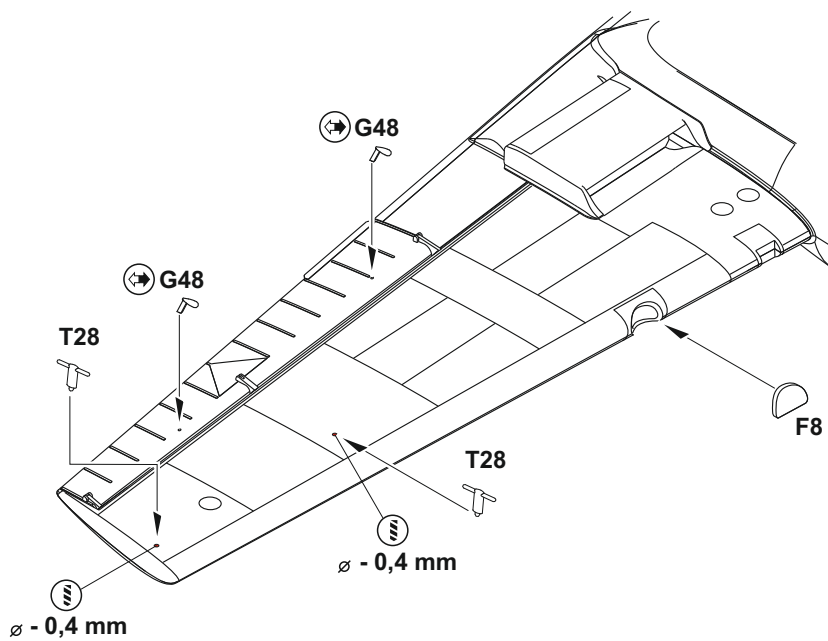
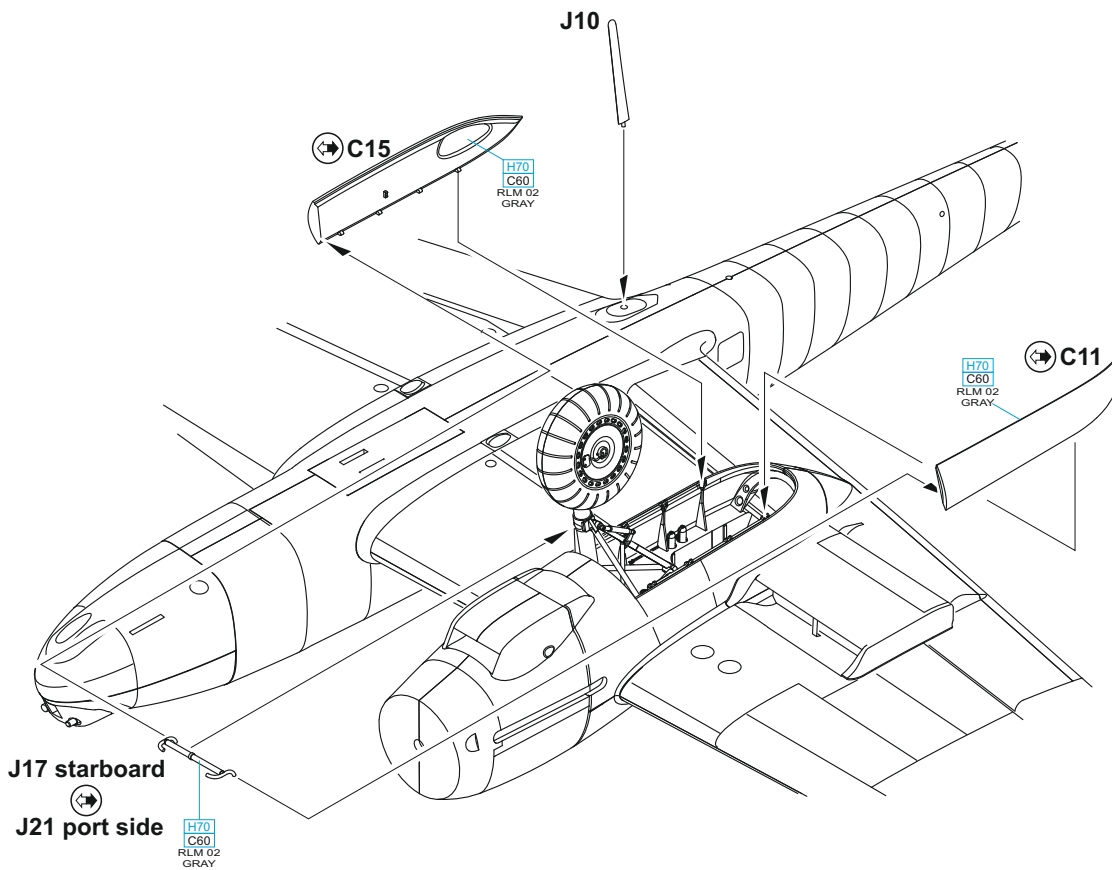

MARKING D

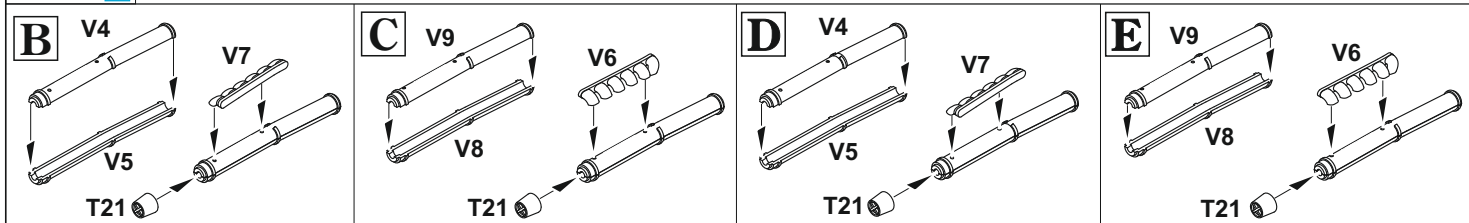

MARKINGS A, B, C

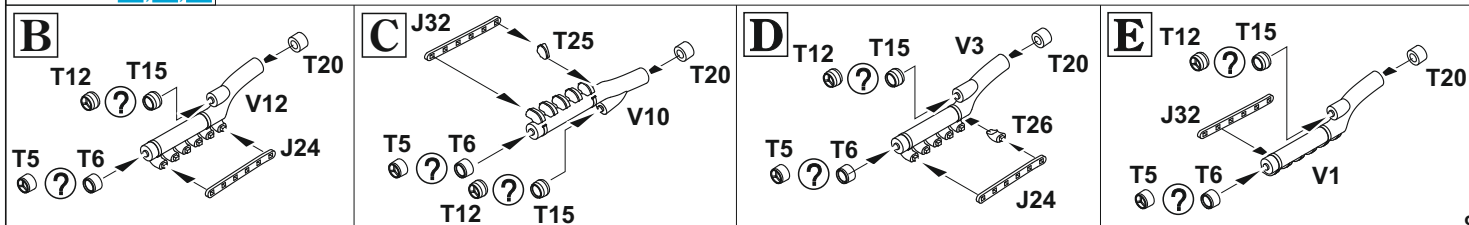

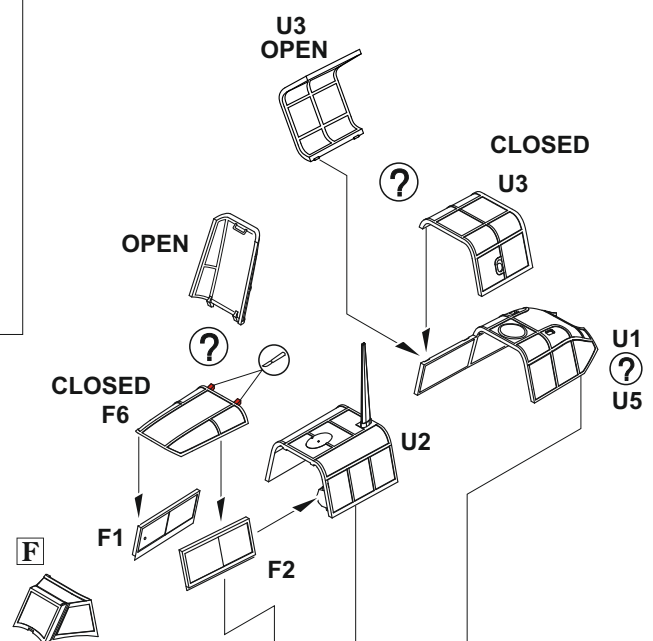
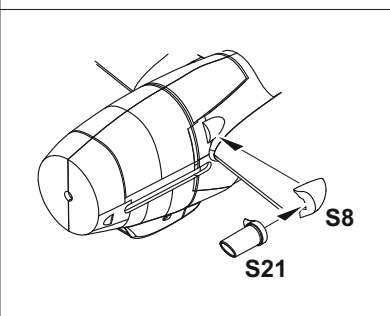
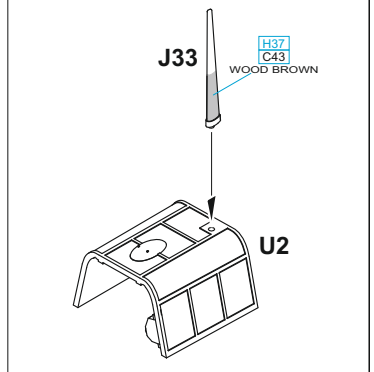
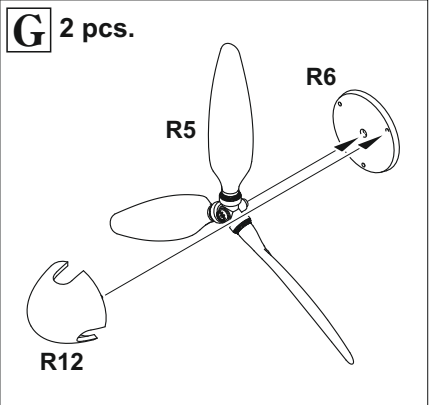
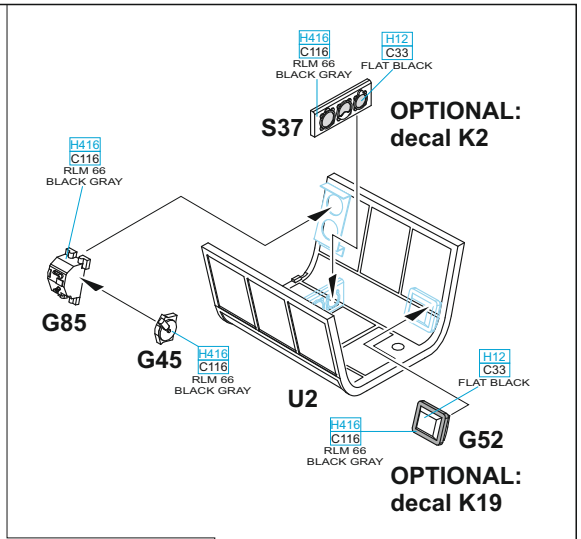
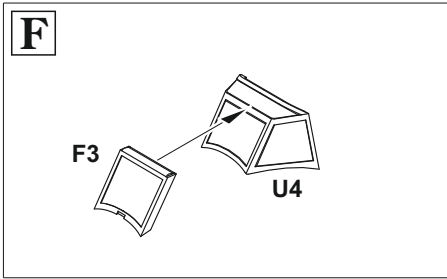

U1 - MARKINGS A, B, D

U5 - MARKING C

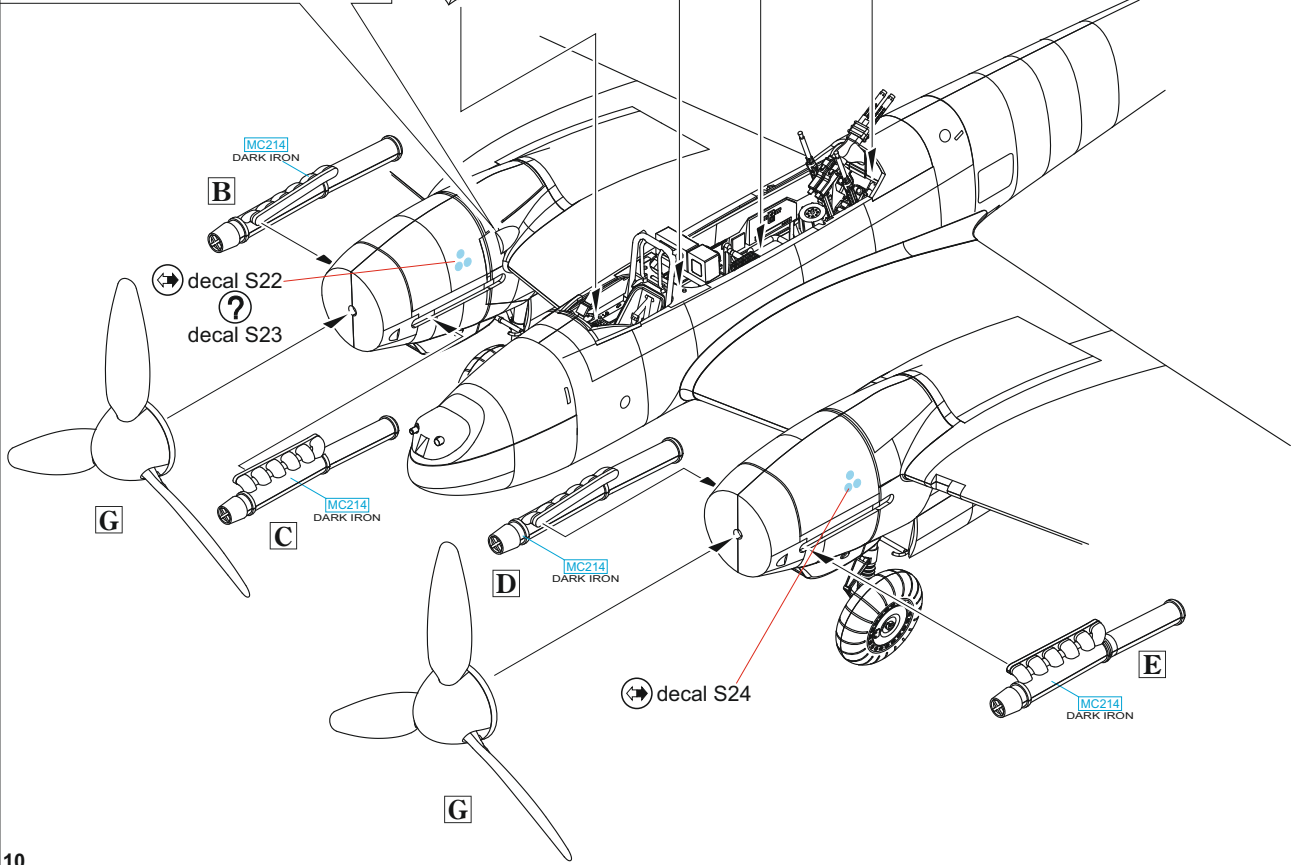

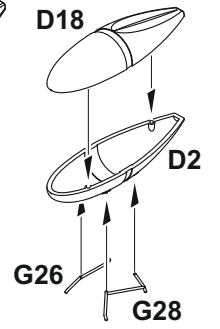
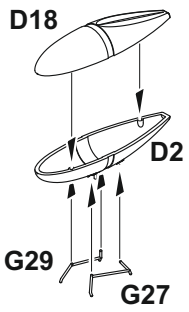
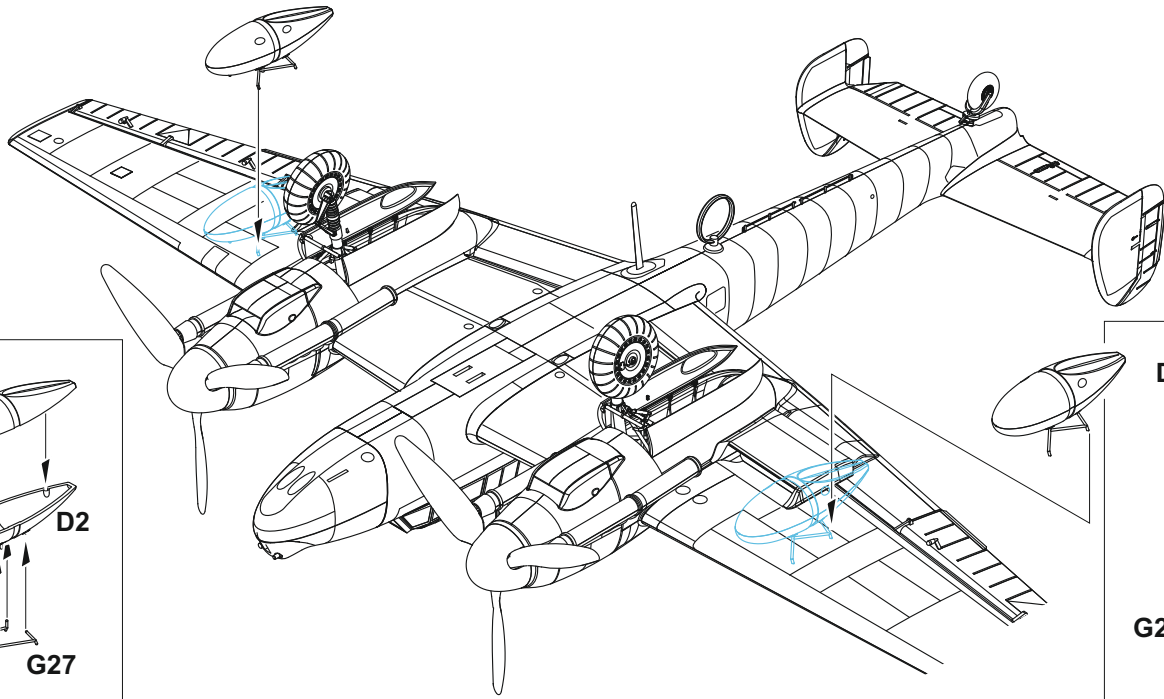

MARKINGS A, B, C

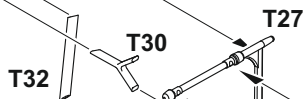
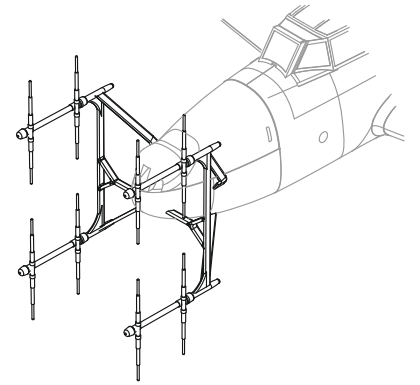
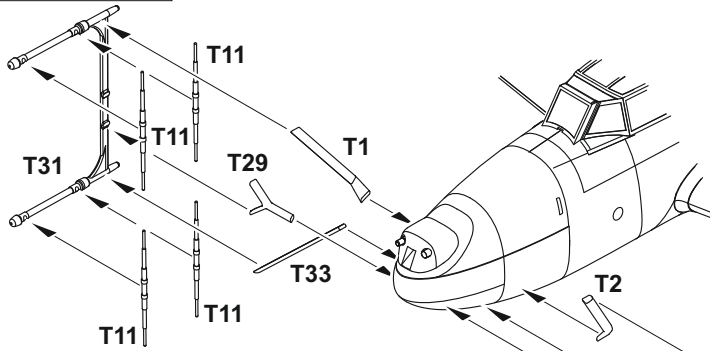

MARKING D

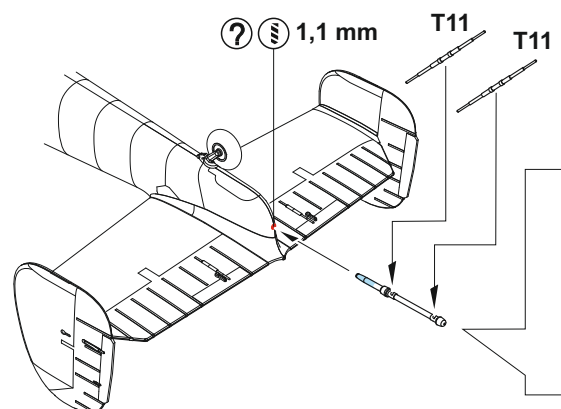
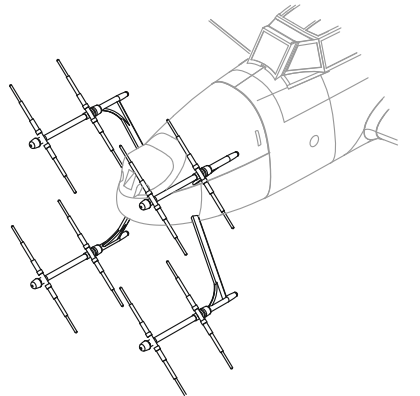
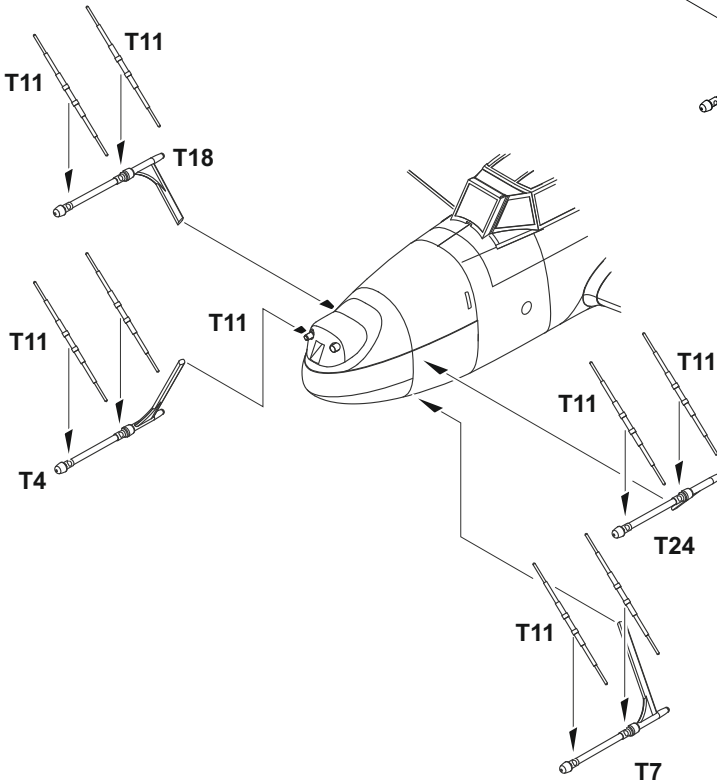

B WNr. 720260, Oblt. Heinz-Wolfgang Schnauer, CO of IV./NJG 1, Sint Truiden, Belgium, April 1944

Heinz-Wolfgang Schnauer, the most successful night fighter ace of all times, recipient of the Knight Cross with Oak Leaves, Swords and Diamonds, flew from the beginning of his military aviation career as a night fighter. In total he shot down 121 enemy aircraft, predominantly four-engine British bombers. During the whole war he was wounded only once and none of his crew members was ever wounded in combat. Schnauer survived the war and at the end of hostilities he decided to concentrate on the family wine business. He died on June 15, 1950, two days after the car crash in which he collided with a truck in Cestas near Bordeaux in France. Schnauer, nicknamed "The Night Ghost of St. Trond", flew this Bf 110G-4 during the spring months of 1944 when he assumed command of IV. Gruppe Nachtjagdgeschwader 1. The aircraft original camouflage of RLM 74 and RLM 75 on the upper surfaces partially showed through the overcoat of RLM 76. The lower and side surfaces remained in the original coat of RLM 76, the starboard wing undersurfaces were painted black. The bottom position weapons were deleted on this aircraft.

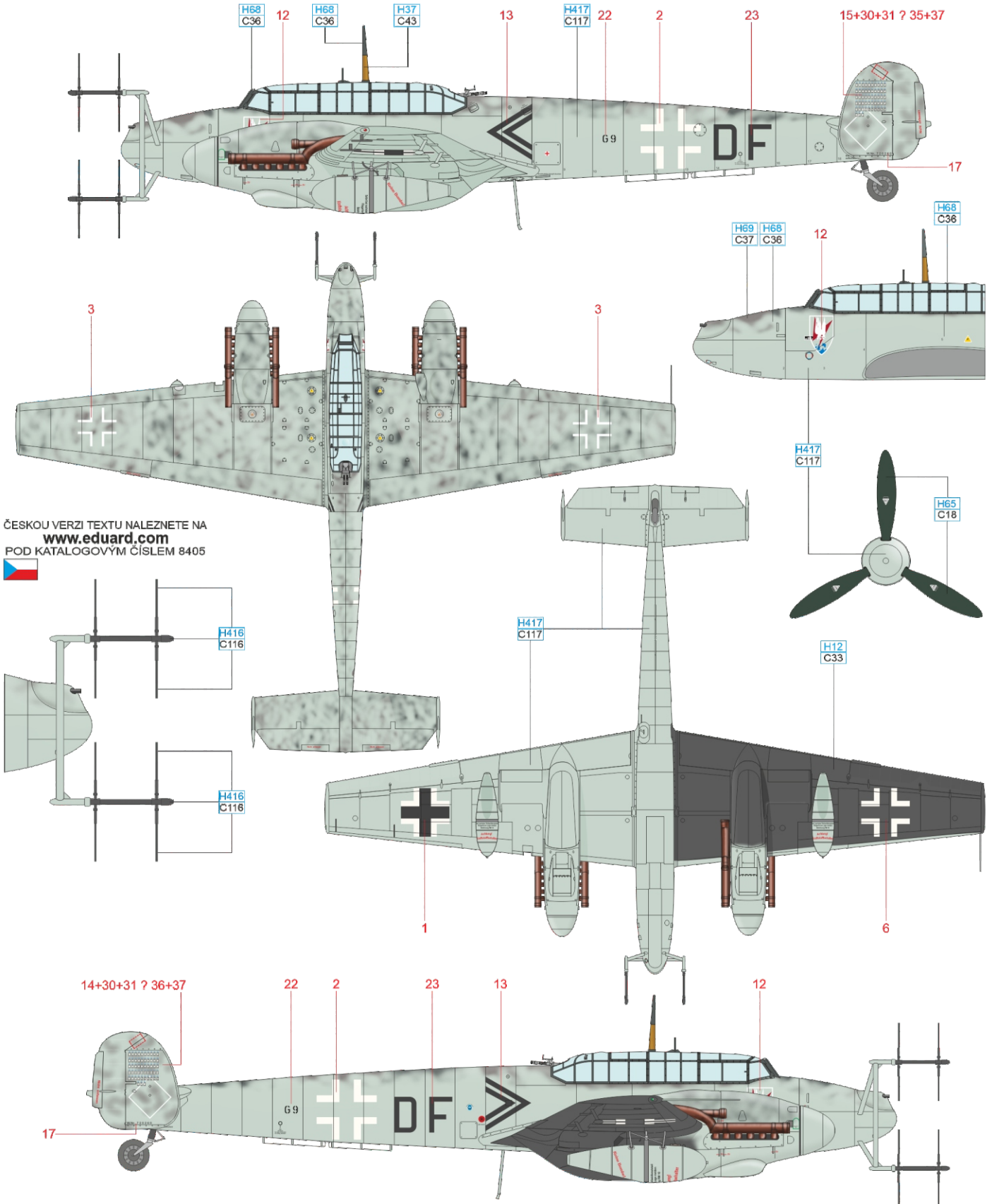

WOOD BROWN	H37 C43	RLM 76	H417 C117	RLM 75	H69 C37	RLM 74	H68 C36	RLM 66	H416 C116	RLM 70	H65 C18	FLAT BLACK	H12 C33
------------	---------	--------	-----------	--------	---------	--------	---------	--------	-----------	--------	---------	------------	---------

The 4./NJG 3 unit was formed in March 1945, out of Nachtjagdstaffel Norwegen, a unit that operated independently from Norway. The purpose of the unit was to intercept allied aircraft over Scandinavia. Besides the Bf 110G, the unit also flew the Ju 88G and He 219. Its last function was on May 8, 1945, evacuating German unit officers from the surrounding areas. Aircraft B4+KA probably did not take part in this final action, because the end of the war found the aircraft still at Kjevik, in Norway. The aircraft carried FuG 220 SN-2b with vertical dipoles, and with an older type of mounting. Originally, the aircraft carried a camouflage scheme of RLM 74 and RLM 75 fields on upper surfaces, and RLM 76 on the undersurfaces, but the upper surfaces were later oversprayed with RLM 76 (apart of the nose) and darkened by "snakes" of RLM 71. Starboard wing undersurfaces and engine cowl were oversprayed in black. This aircraft is recorded as crewed by Fw. Kurt Keilig (pilot), Fw. Kurt Schroter (radio operator) and Uffz. Karl Stamminger (mechanic).

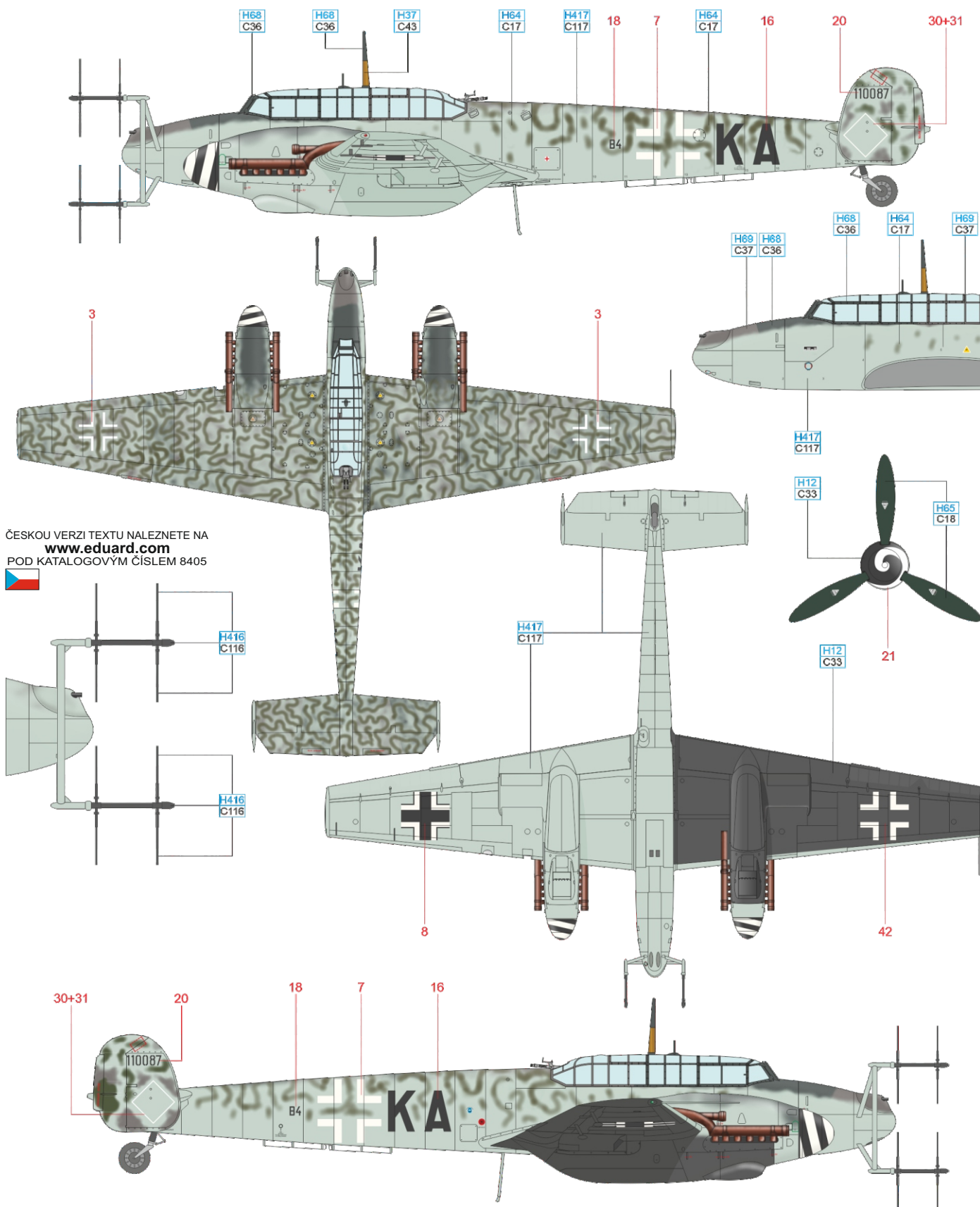

ČESKOU VERZI TEXTU NALEZNETE NA
www.eduard.com
 POD KATALOGOVÝM ČÍSLEM 8405

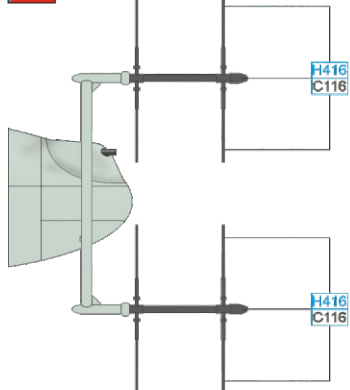

D Hptm. Wilhelm Johnen, CO of III./NJG 6, Neuberg, Germany, 1945

Messerschmitt Bf 110G-4 coded ZZ+FR from 7./NJG 6 was one of the aircraft the Allies found at the Neuberg airbase in the spring of 1945. Even though according to its codes it belonged to 7. Staffel it was actually a personal aircraft of Wilhelm Johnen, III./NJG 6 commanding officer. This airplane is much less known than the other Johnen's aircraft coded C9+EN in which he performed an emergency landing due to the damaged engine in the night of April 27-28, 1944. Bf 110G-4 ZZ+FR was his last aircraft from the later production, equipped with the FuG 220 SN-2d antennae with dipoles fixed at 45 degrees, Eberspächer type exhausts and Schräge Musik cannons. The whole aircraft was oversprayed in RLM 76, upper surfaces were darkened by small patches of RLM 75. According to photos, the aircraft lacked weapons in the bottom of the nose.

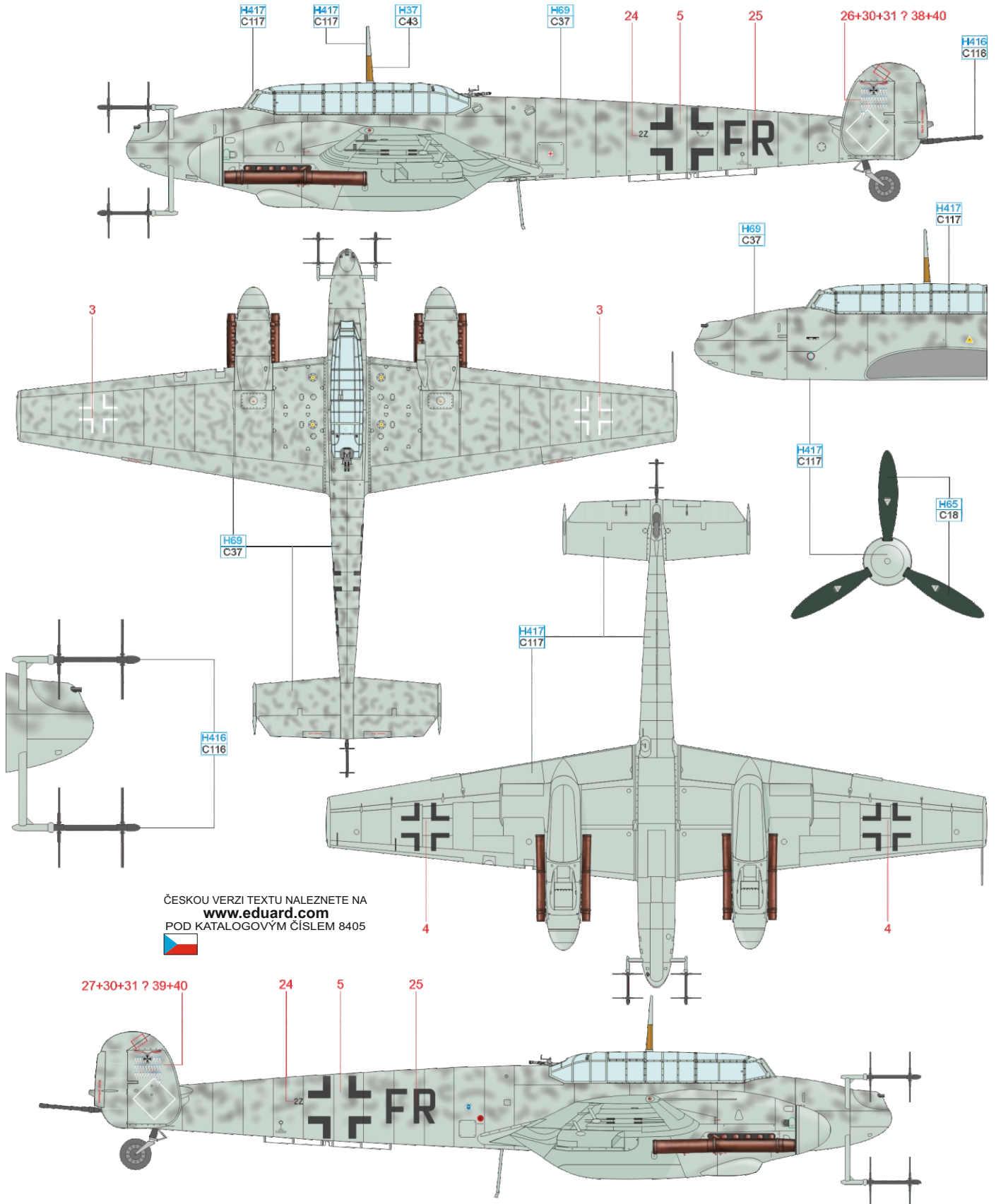

ČESKOU VERZI TEXTU NALEZNETE NA
www.eduard.com
 POD KATALOGOVÝM ČÍSLEM 8405



