

Bf 109G-10

item No. R0022

No other aircraft is so intimately connected with rise and fall of the German Luftwaffe during the WWII like the Messerschmitt Bf 109. It became the true workhorse of the war.

The history of the Bf 109 begins with the requirement L.A. 1432/33 issued by Reich Ministry of Aviation (RLM) in late March 1933. It called for the development of a single-engined monoplane fighter. Proposals were submitted by Arado, Heinkel, Focke-Wulf and Bayerische Flugzeugwerke. The design bureau of the last-mentioned company was led by its technical director Willy Messerschmitt, who was riding a wave of popularity based on the success of his liaison aircraft, the Bf 108. Messerschmitt's goal was to create an aircraft with the best possible performance for the specified weight and size. Over the subsequent months, several prototypes were built that served first and foremost in development flights and further modifications. The aircraft was relatively small, and compared to the prevailing trends of the time, sported several quite revolutionary features such as low wing design, retractable landing gear, wing with a thin airfoil, wing slats, landing flaps, weapons firing through the propeller hub, and so on. Even the enclosed cockpit and the method of the airframe design were not very common just four years prior to the beginning of the Second World War. At its conception, the Bf 109 was a very promising asset despite some powerplant troubles. These were solved by the introduction of the DB 601. This engine, together with its extrapolated development DB 605, is umbilically connected to the success of the Bf 109. These two-row, twelve-cylinder inverted V engines powered tenths of thousands of 109s in over 25 versions and variants.

From Spanish War to the Reich Defence

The first combat use of Bf 109 occurred during Spanish Civil War, where three developmental Bf 109s were deployed in December 1936. The main reason of revealing the modern fighter to the world was quite down-to-earth: To validate its abilities in modern aerial combat. Shortly thereafter, production aircraft in the form of the Bf 109B-1 began to reach 2.J/88, the Legion Condor. The desire of Germany to demonstrate its aerial prowess to potential foes was advanced further in international sport meets. The triumphs attained in Zurich in the summer of 1937 were complemented several months later by grabbing the speed record of 379.63 mph (610.95 km/h). In very short order, the progressive developments represented by the C, D and E versions appeared. Despite this, the delivery of the aircraft to combat units did not sustain a rate that was desired by military brass. Even by August 1938 the Bf 109 accounted for less than half of the 643 front line fighters in service. The later months saw an increase in these rates. By the time of the invasion of Poland (which saw the participation of only a little more than 200 aircraft) the Luftwaffe possessed the best fighter produced in continental Europe. The elegance of the Bf 109 crested with the "Friedrich". Following a largely defensive stance over the Channel and northern France, the Bf 109F took on a more offensive role in Operation Barbarossa in the east, and in northern Africa. In later

duties with the "Jagdwaffe" during the second phase of the war in the east, and in the "Defence of the Reich" from 1943 to 1945, the Bf 109s served in the form of the G version, followed by the K. Even if it was clear the development of the Bf 109 was depleted by the end of the war, the aircraft was still able to keep pace with the foes that it encountered. Besides its primary purpose as a fighter, the Bf 109 also appeared as a fighter-bomber, reconnaissance, night fighter, trainer and rammjäger.

The kit: Bf 109G-10 Erla

The Bf 109G (Gustav) was a direct successor to the Bf 109F. The main difference was the more powerful DB 605 engine, which was a further development of the DB 601. There were several versions and subversions of the Bf 109G and its development was reaching the new stage with the Bf 109K (Kurfürst) variant. For Kurfürst, new DB 605D unit was prepared, however, this one was also used for an interim solution that was developed at the Erla factory. It was based on the airframe of the G-14 design, which had appeared in July 1944 as a replacement for the G-6, incorporating all the minor improvements of the G-6. The DB 605D engine, like the DB 605AS one, received a larger supercharger from the DB 603, as well as automatic altitude-dependent supercharger rpm control. Deliveries of the DB 605DM and DMO engines began during summer of 1944, the main production version was the DB 605DB using B4 gasoline with the MW50 system, and the DB 605DC, using 96-octane C3 gasoline and without the MW50 system.

The DB 605D engines were exclusively installed together with larger FO 987 type oil coolers, a larger 54-litre oil tank and a larger compressor air intake. Production of the Bf 109G-10 ran from the autumn of 1944, common features also included larger ALF 907C wing radiators instead of the original ALF 750B, larger air intake to the compressor and larger VDM 9-12159 type propellers with wider propeller blades. A canopy with simplified Erlahaube framing and a tall rudder became standard as well. The Bf 109G-10 was produced at the Erla Leipzig, Messerschmitt AG Regensburg and Wiener Neustädter Flugzeugwerke. And although the G-10 version was intended to be a transitional type before production of the heavily modernized Bf 109K began, in fact the first Erla Leipzig-produced aircraft did not reach Luftwaffe units until October 1944, essentially at the same time as the first Bf 109K-4s.

The Erla aircraft differed from the examples of other two manufacturers, as they sported different engine cowling. It lacked the blister fairings forward and below of the exhaust stacks. These were necessitated by enlarged engine crankcase and different oil lines. But the Erla factory designed new cowlings, while WNF and Mtt Reg. applied the fairings to the original ones. Some 2,600 of the Bf 109G-10 were produced, the production ended in March 1945.

ATTENTION



UPOZORNĚNÍ



ACHTUNG



ATTENTION



注意



Carefully read instruction sheet before assembling. When you use glue or paint, do not use near open flame and use in well ventilated room. Keep out of reach of small children. Children must not be allowed to suck any part, or pull vinyl bag over the head.



Před započítím stavby si pečlivě prostudujte stavební návod. Při používání barev a lepidel pracujte v dobře větrané místnosti. Lepidla ani barvy nepoužívejte v blízkosti otevřeného ohně. Model není určen malým dětem, mohlo by dojít k požití drobných dílů.

INSTRUCTION SIGNS * INSTR. SYMBOLS * INSTRUKTION SINNBILDEN * SYMBOLES * 記号の説明

OPTIONAL
VOLBABEND
OHNOUTSAND
BROUSITOPEN HOLE
VYVRTAT OTVORSYMETRICAL ASSEMBLY
SYMETRICKÁ MONTÁŽREMOVE
ODŘÍZNOUTREVERSE SIDE
OTOČITAPPLY EDUARD MASK
AND PAINT
POUŽIT EDUARD MASK
NABARVITPLEASE, CHECK THE LATEST VERSION OF THE INSTRUCTIONS ON www.eduard.com

PARTS



DÍLY



TEILE



PIÈCES



部品

O>

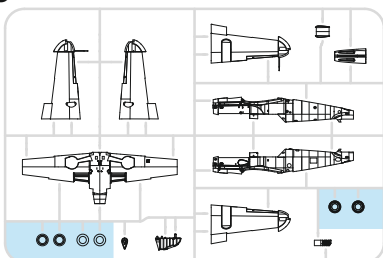

P> 2 pcs.

PLASTIC PARTS

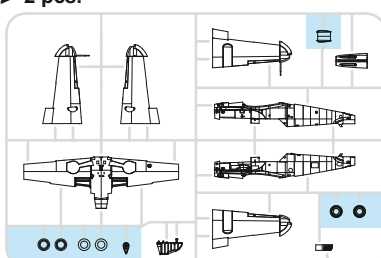

U> 2 pcs.

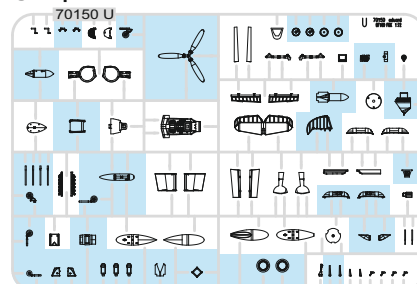

J> 2 pcs.

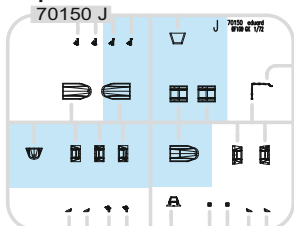

V> 2 pcs.

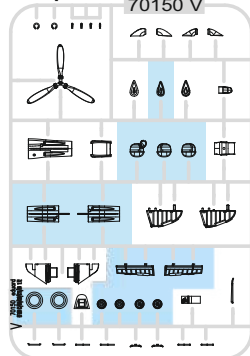

PE - PHOTO ETCHED DETAIL PARTS

2 pcs.



2 pcs.

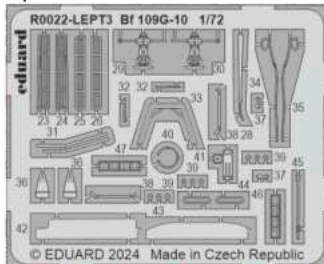

RP - RESIN PARTS

RP14
2 pcs.RP13
2 pcs.

RP65 2 pcs.



RP66 2 pcs.



RP111

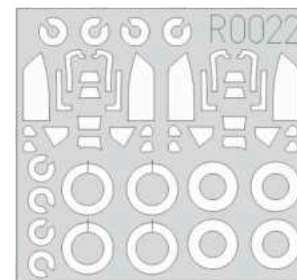

RP110

RP112
2 pcs.

-Parts not for use. -Teile werden nicht verwendet. -Pièces à ne pas utiliser. -Tyto díly nepoužívejte při stavbě. - 使用しない部品

COLOURS



BARVY



FARBEN



PEINTURE



色

GSI Creos (GUNZE)		
AQUEOUS	Mr.COLOR	
H2	C2	BLACK
H11	C62	FLAT WHITE
H12	C33	FLAT BLACK
H43	C100	WINE RED
H47	C41	RED BROWN
H64	C17	RLM71 DARK GREEN
H65	C18	RLM70 BLACK GREEN
H68	C36	RLM74 DARK GRAY
H69	C37	RLM75 GRAY
H70	C60	RLM02 GRAY
H74	C26	GREEN BLUE
H77	C137	TIRE BLACK
H90	C47	CLEAR RED
H94	C138	CLEAR GREEN
H319	C319	LIGHT GREEN
H324	C324	LIGHT GRAY

GSI Creos (GUNZE)		
AQUEOUS	Mr.COLOR	
H413	C113	RLM04 YELLOW
H414	C114	RLM23 RED
H416	C116	RLM66 BLACK GRAY
H417	C117	RLM76 LIGHT BLUE
H421	C121	RLM81 BROWN VIOLET
H422	C122	RLM82 LIGHT GREEN
Mr.METAL COLOR		
MC213		STEEL
MC214		DARK IRON
MC219		BRASS
Mr.COLOR SUPER METALLIC		
SM201		SUPER FINE SILVER
Mr.COLOR GX		
GX05		SUSIE BLUE

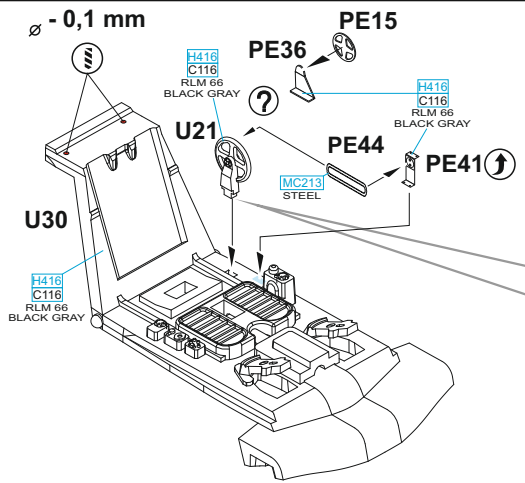

R0022 - LEPT1 - MARKINGS **A, B, C, D, E, F, G, H**
 R0022 - LEPT2 - MARKINGS **I, J**

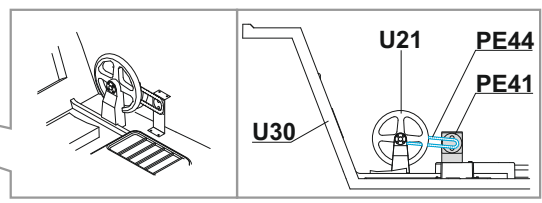

A
 MARKINGS **A, B, C, D, E, F, G, H**

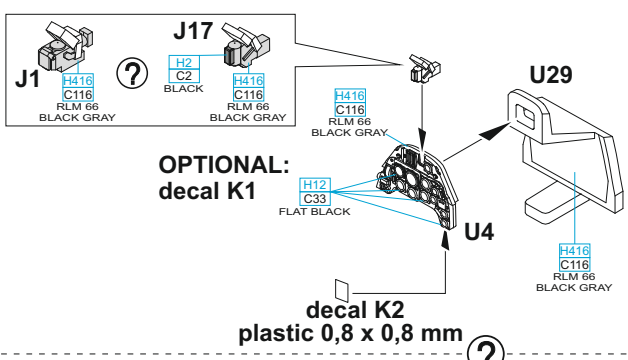

MARKINGS **I, J**

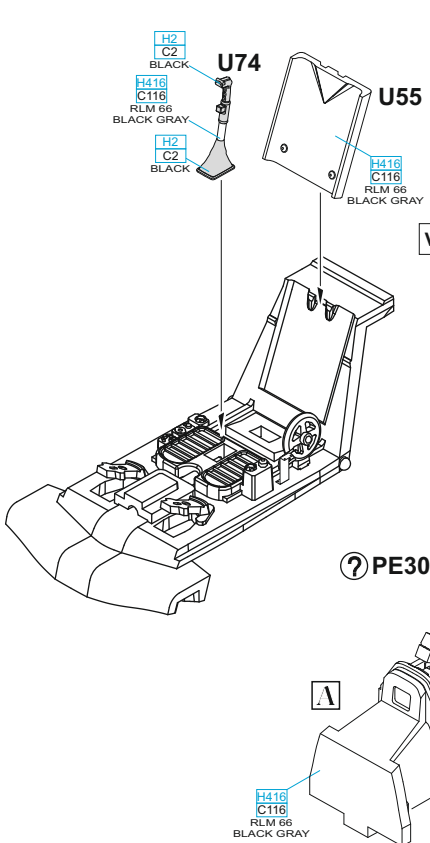
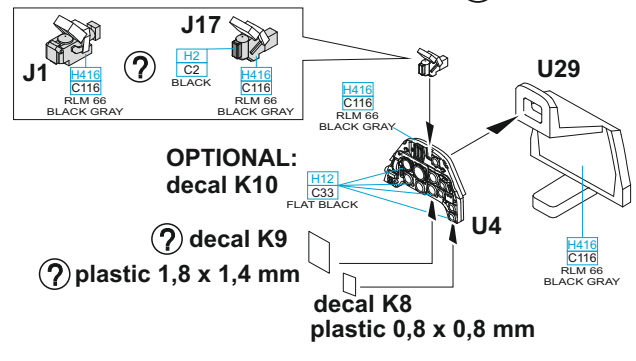

V11 - MARKINGS **A, B, C** ONLY

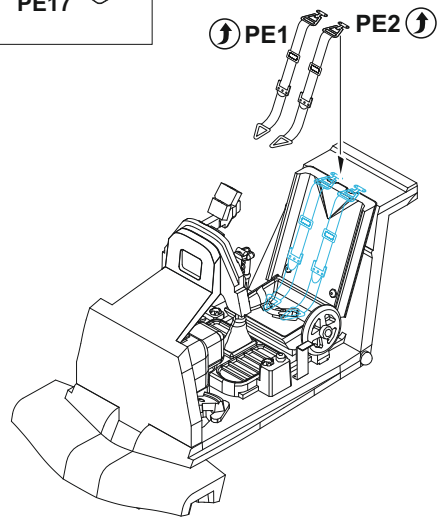
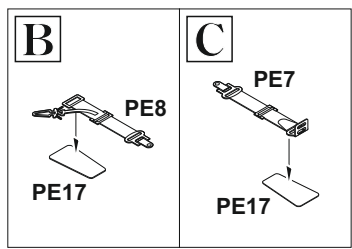

O7, O15 - MARKINGS F, G, H

P7, P15 - MARKINGS A, B, C, D, E, I, J

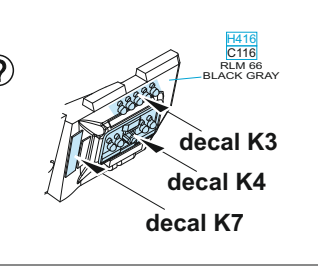
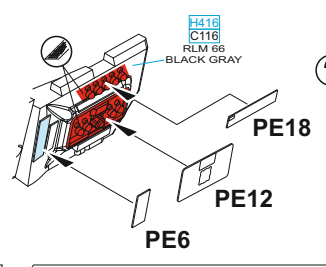
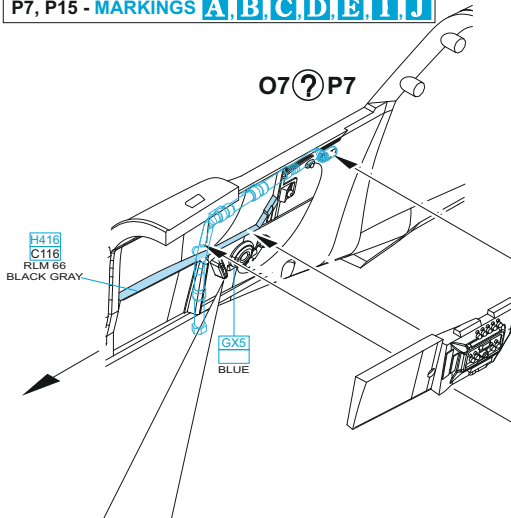

O8 - MARKINGS F, G, H
P8 - MARKINGS A, B, C, D, E, I, J

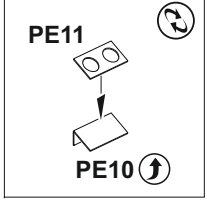
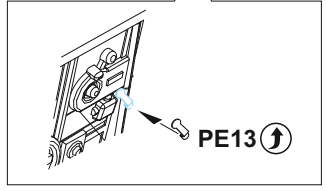
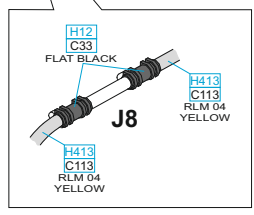
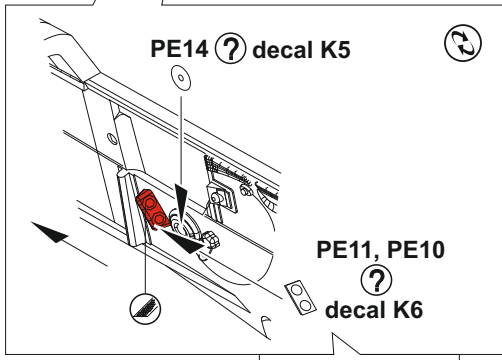
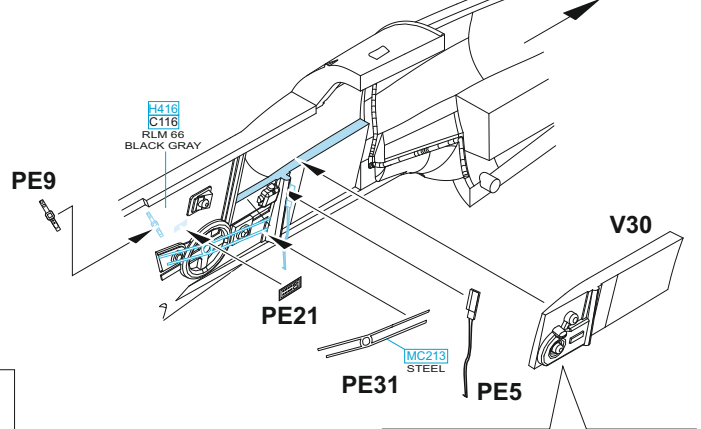

V23 - MARKINGS A, B, C, D, E, F, G, H
V22 - MARKINGS I, J

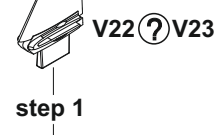

P7, P8 - MARKINGS A, B, C, D, E, I, J
O7, O8 - MARKINGS F, G, H

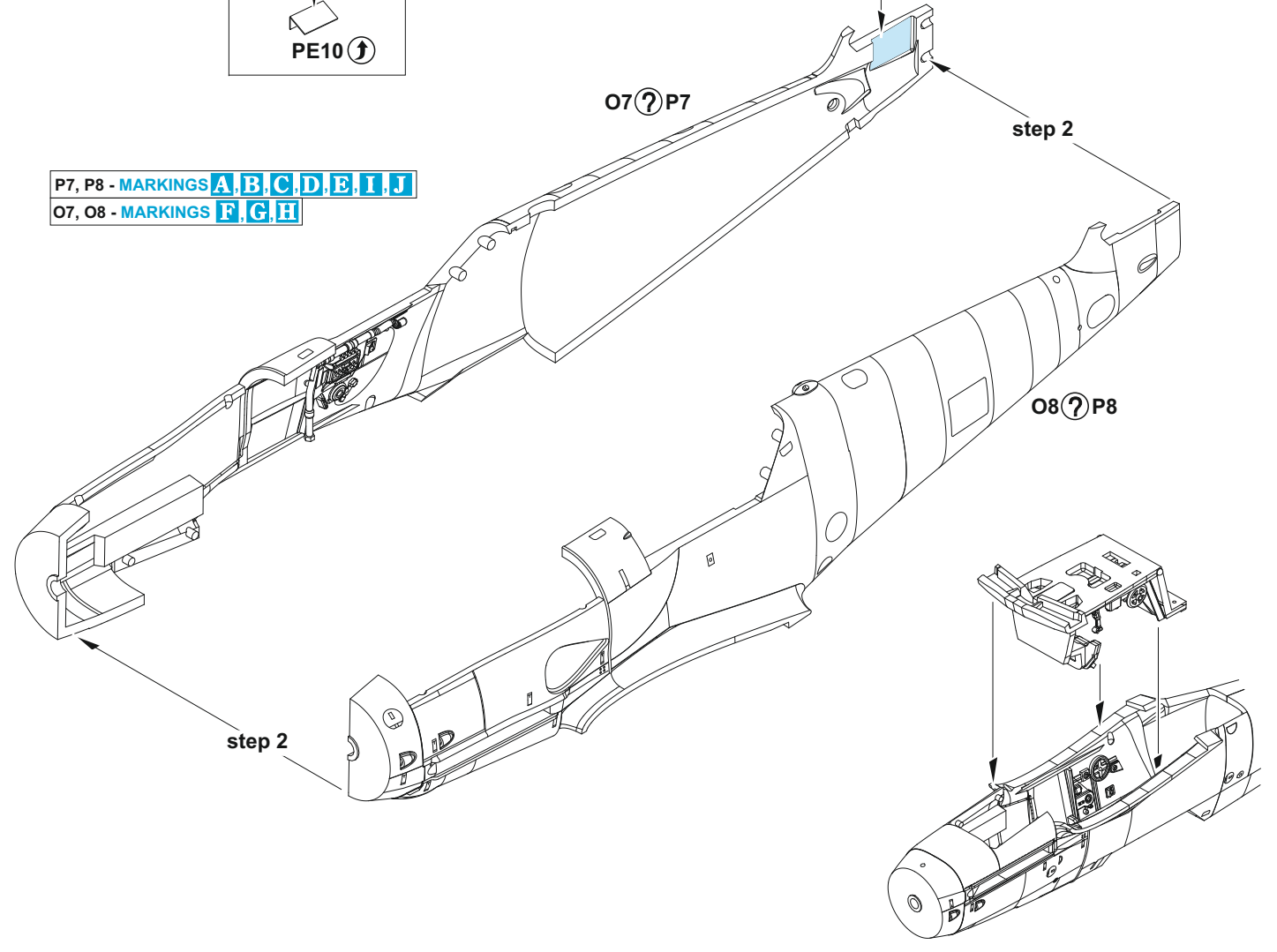

H77
C137
TIRE BLACK

U11

H70
C60
RLM 02
GRAY

U12

H77
C137
TIRE BLACK

O1 ? P1

O1 - MARKINGS F, G, H

P1 - MARKINGS A, B, C, D, E, I, J

O3 ? P3

∅ - 0,6 mm ?

CENTRAL RACK

J19

O13 ? P13

?

O2 ? P2

O4 ? P4

H70
C60
RLM 02
GRAY

P4, P13 - MARKINGS A, B, C

P2, P3 - MARKINGS D, E, I, J

O2, O3 - MARKINGS F, G

O4, O13 - MARKING H

O1 ? P1

CLOSE

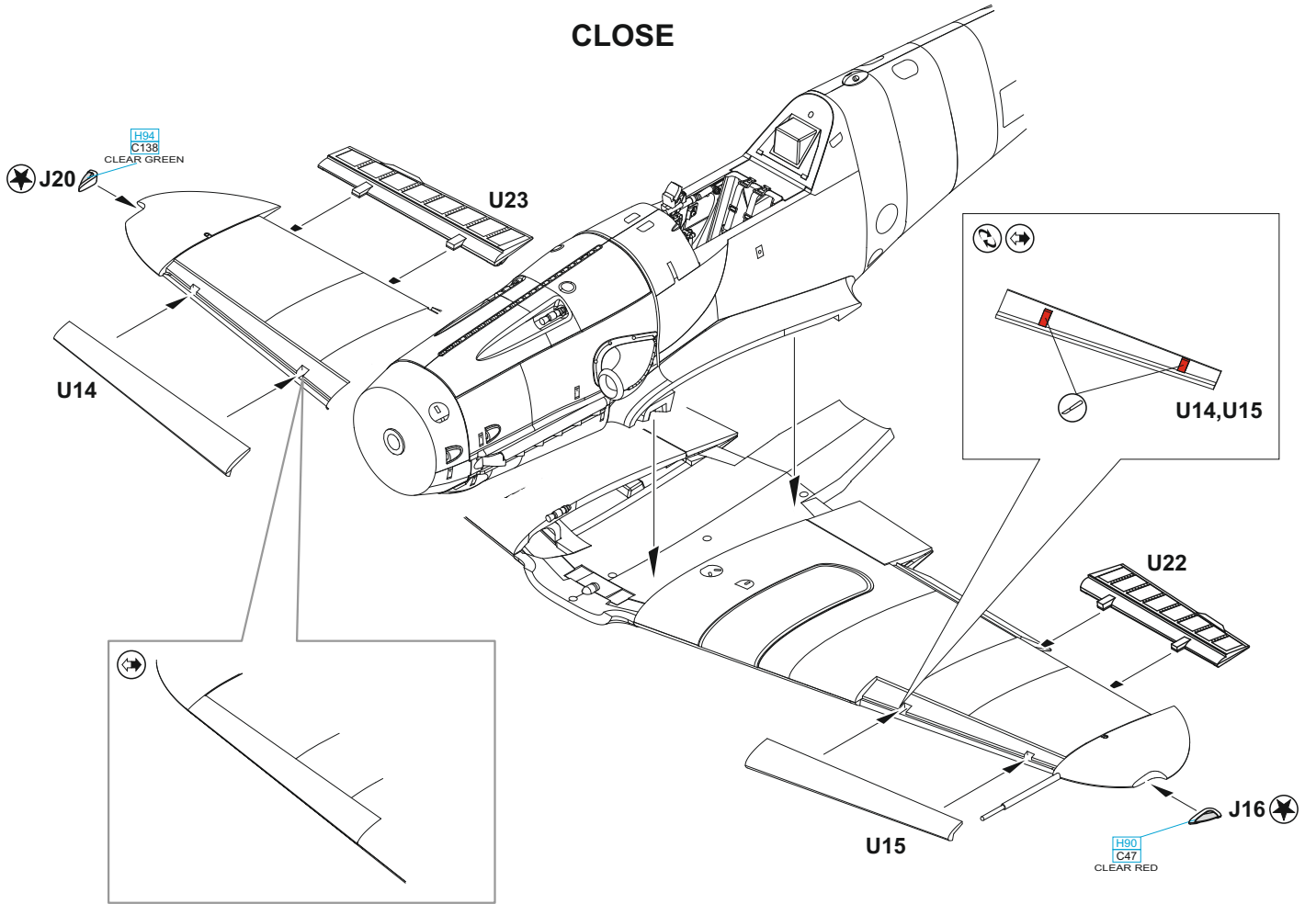

OPEN

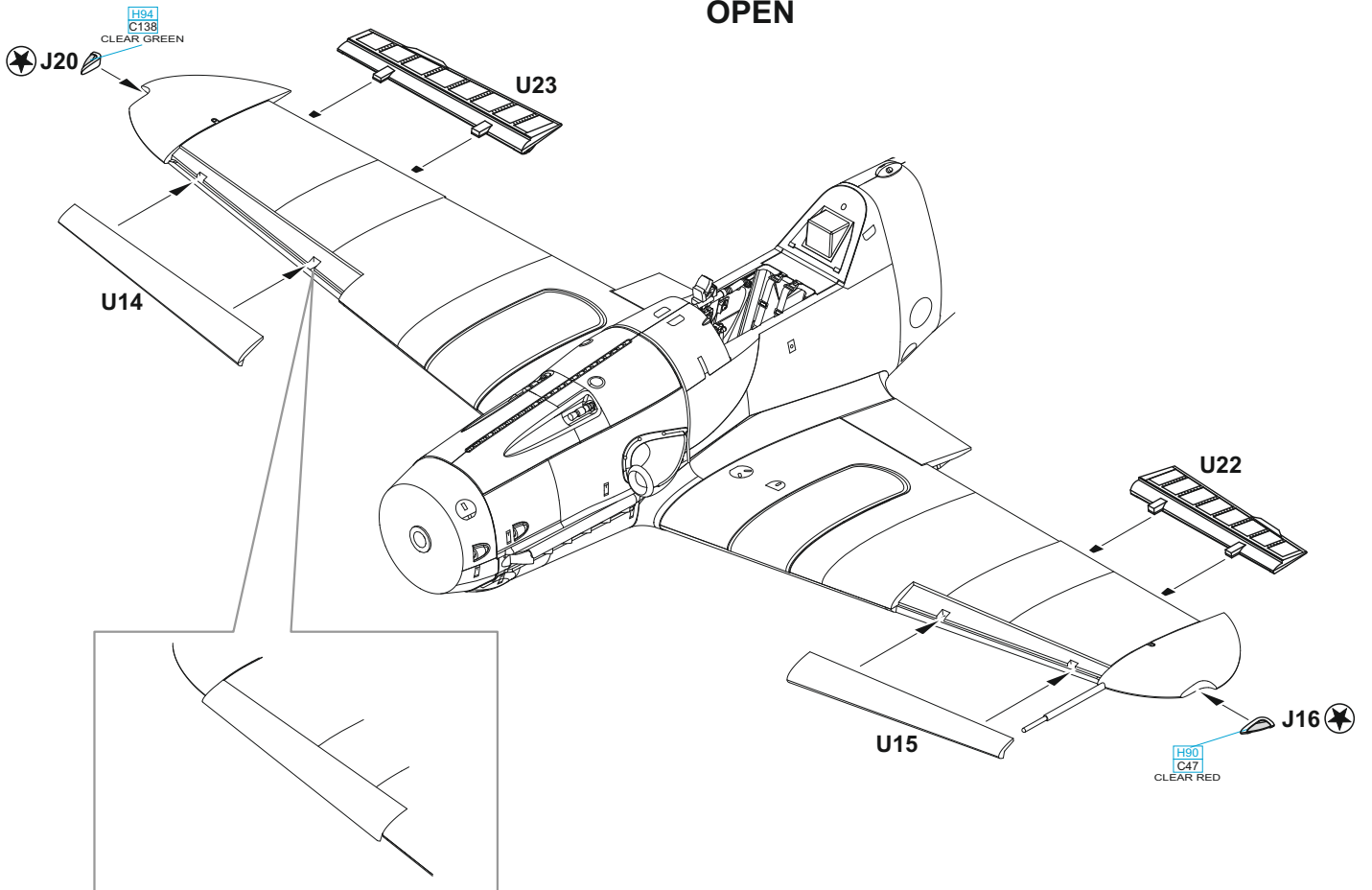

FRONT VIEW

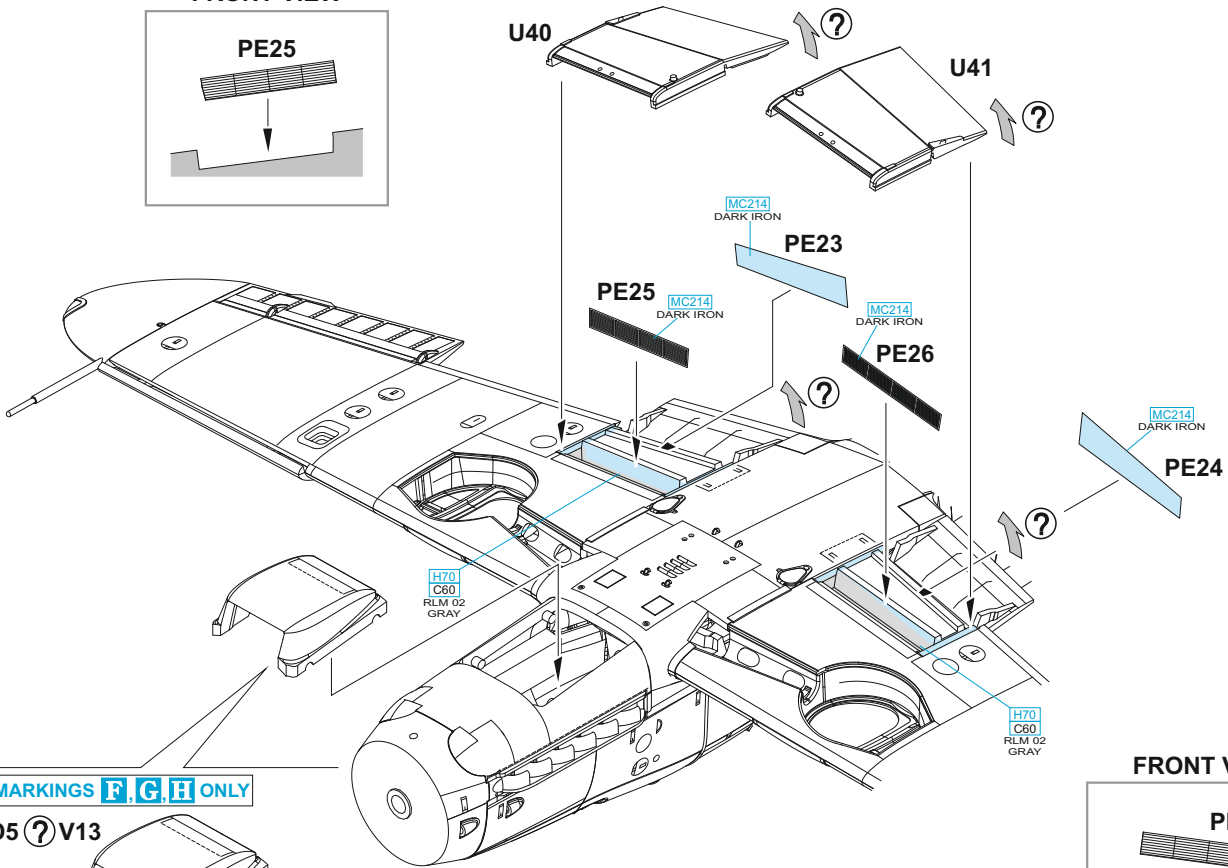
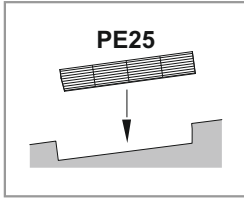

FRONT VIEW

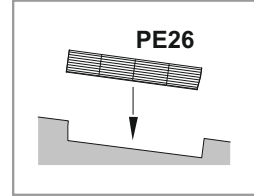

O5 - MARKINGS F, G, H ONLY

O5 ? V13

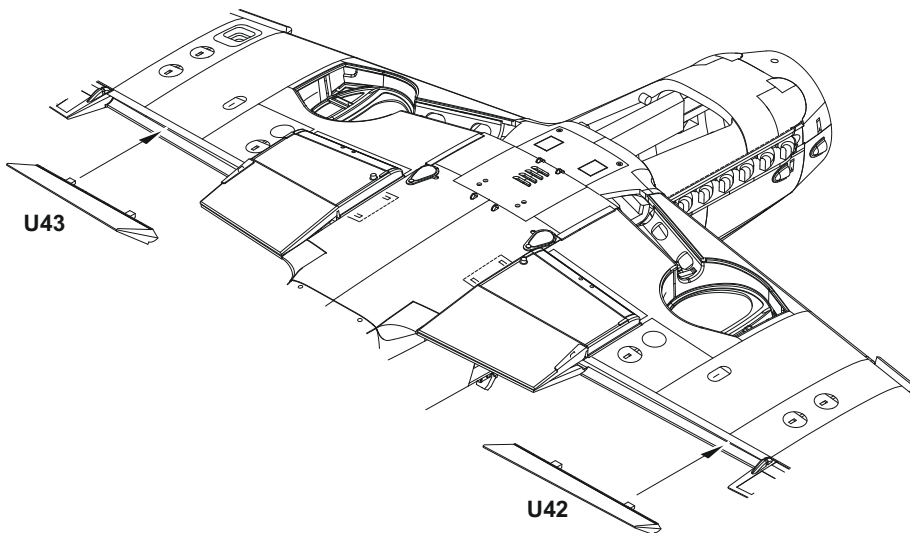
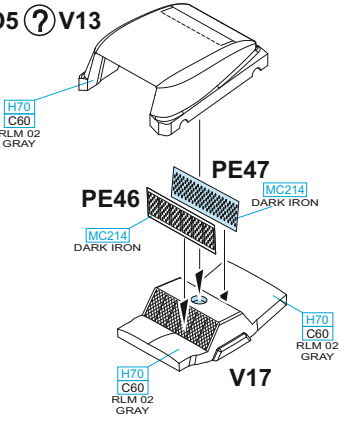

RP110, RP111 - MARKINGS **A B C H**
 RP65 - MARKINGS **D E F G I J**

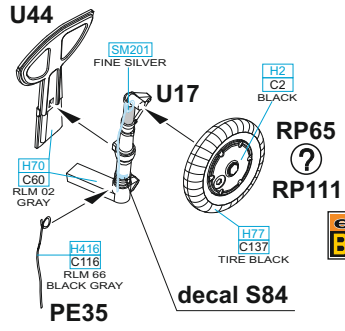
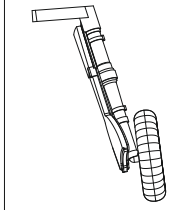
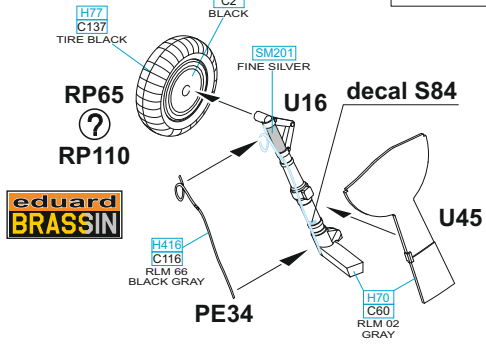
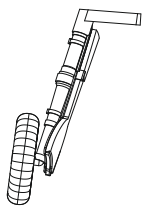

RP66 - MARKINGS **A B C**
 RP112 - MARKINGS **D E F G H I J**

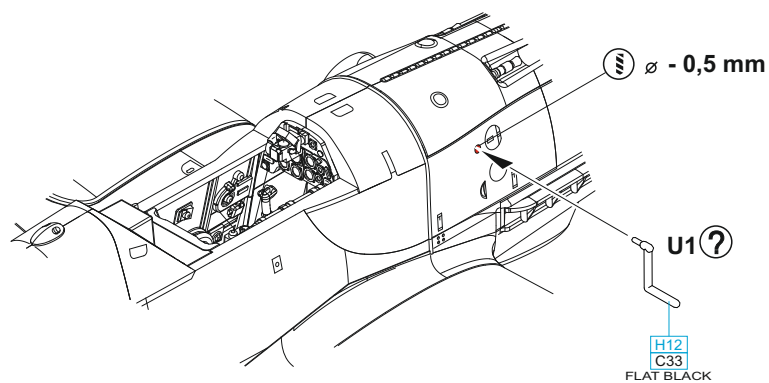
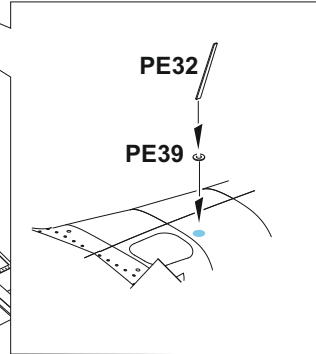
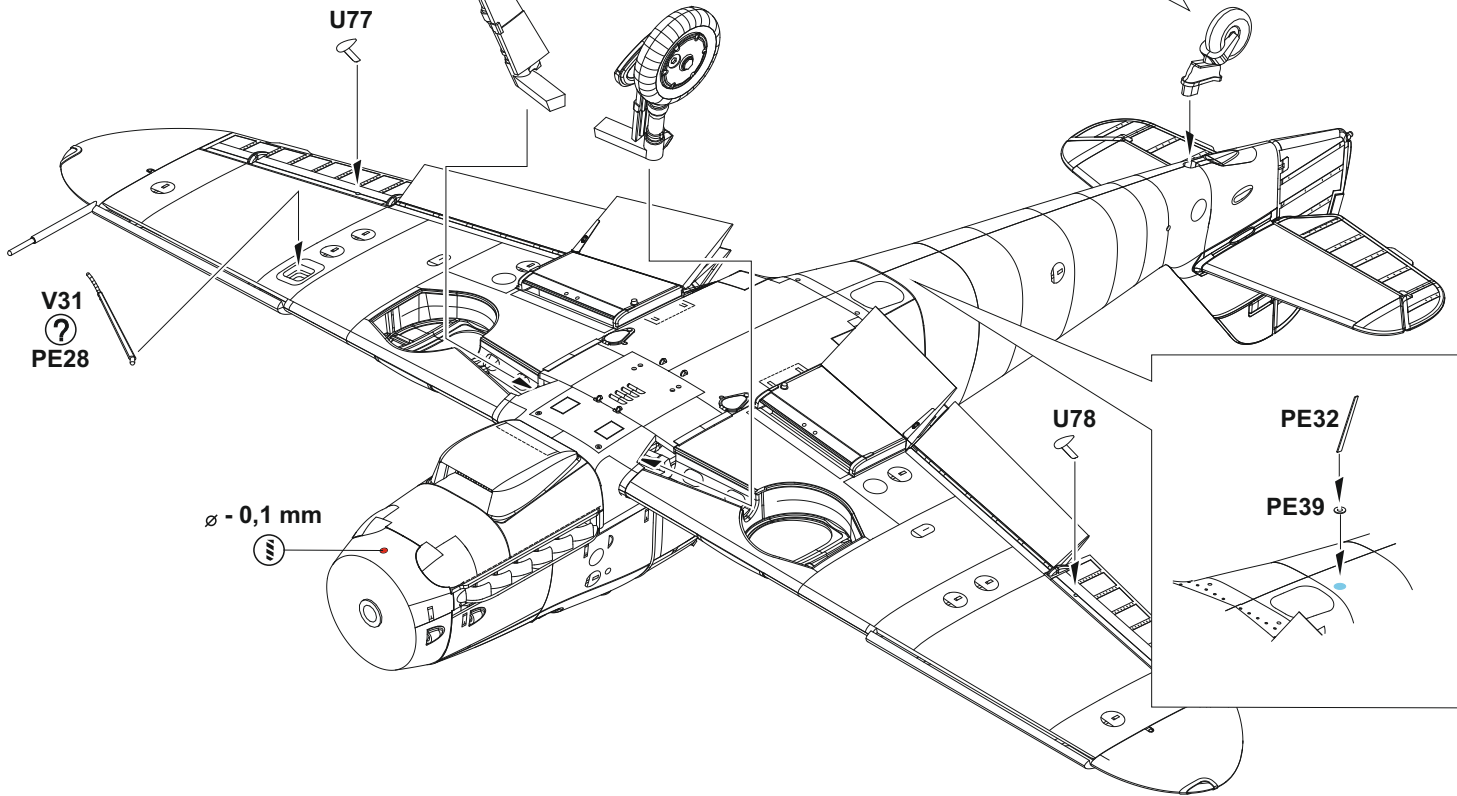
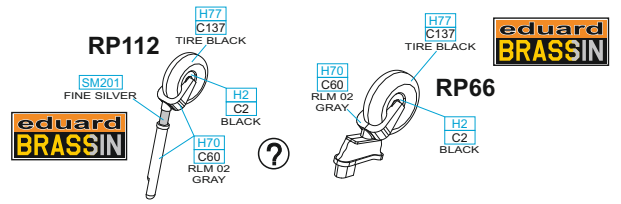

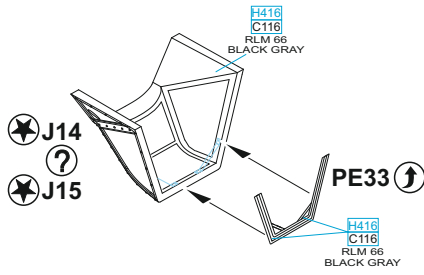

J14 - MARKINGS **F, G, H**
 J15 - MARKINGS **A, B, C, D, E, I, J**

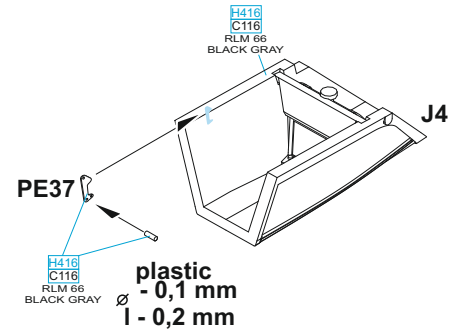
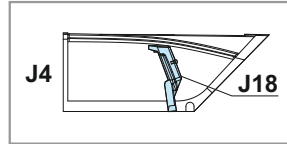
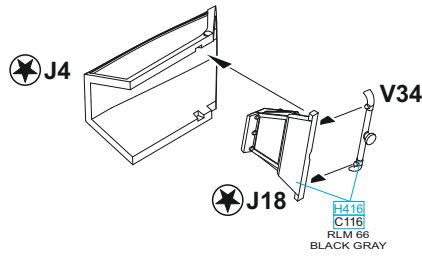

plastic
 - 0,1 mm
 l - 0,2 mm

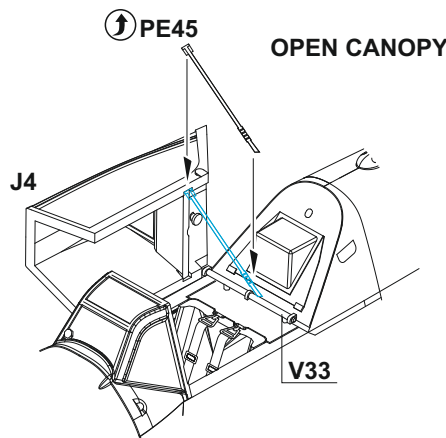
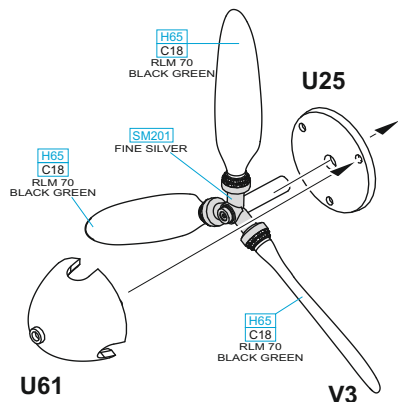
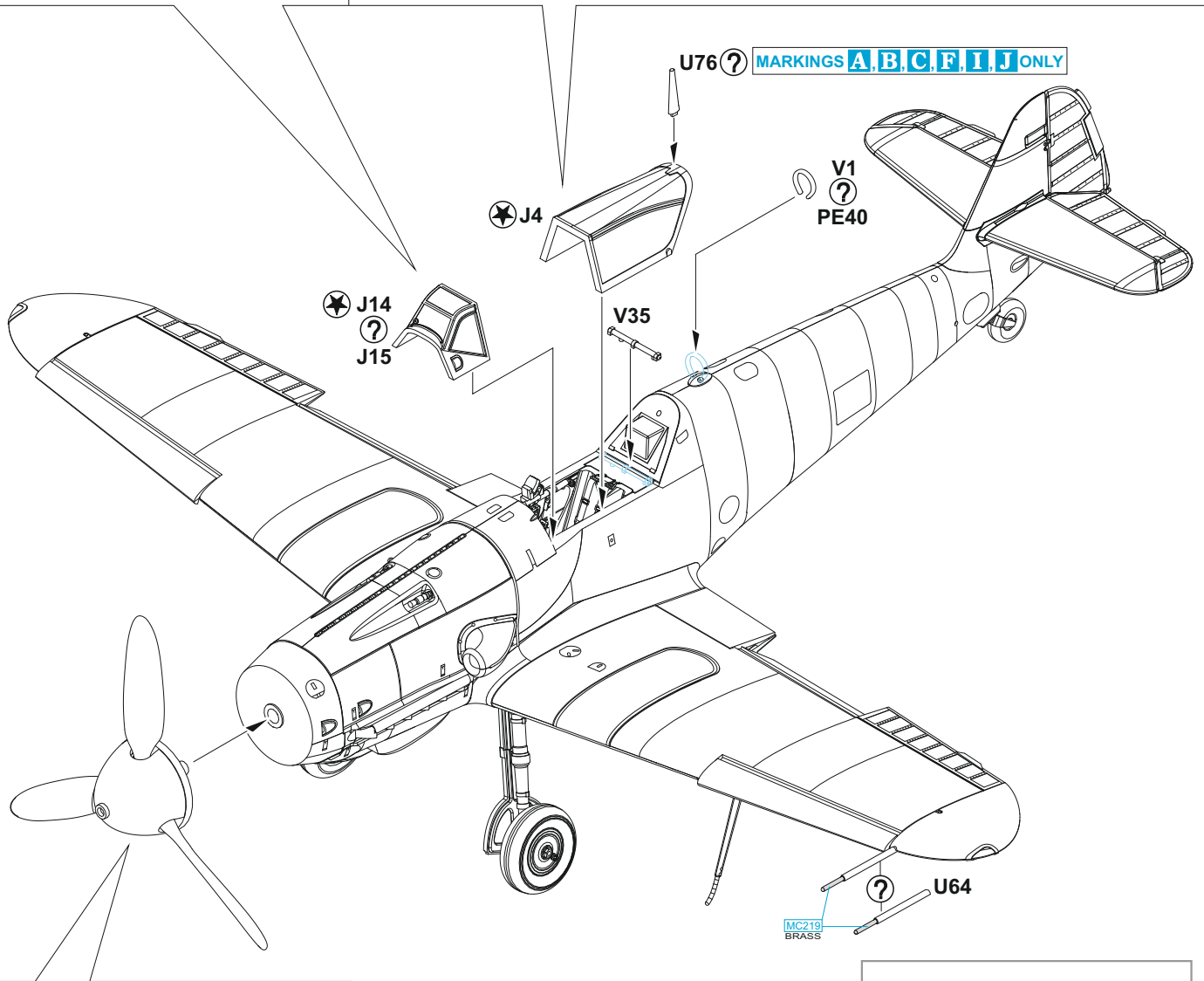

OPEN CANOPY

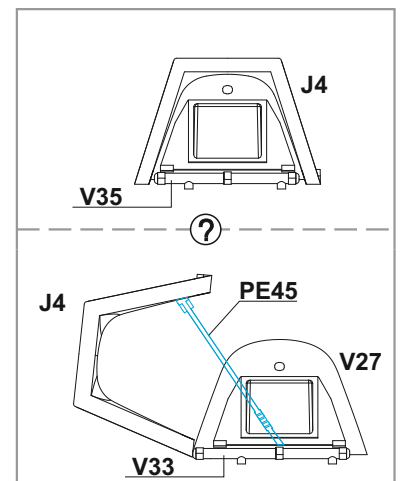

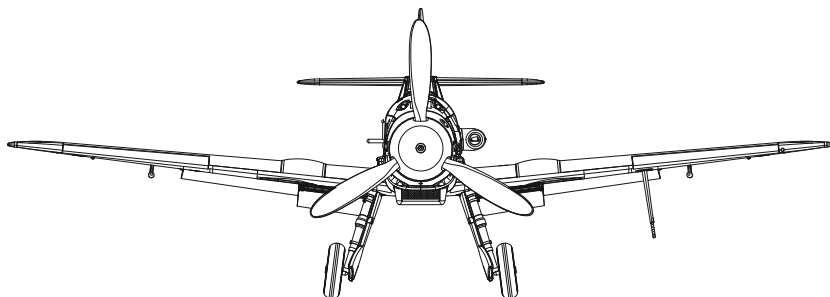
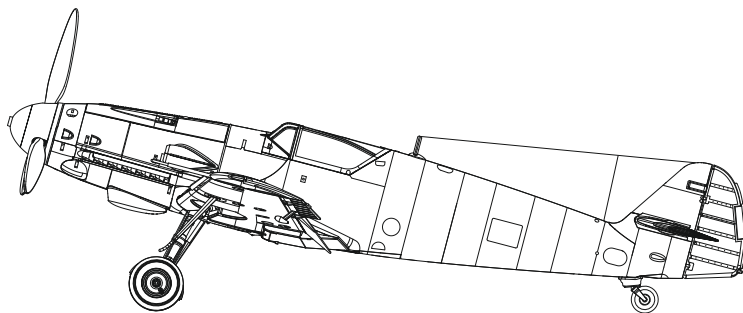
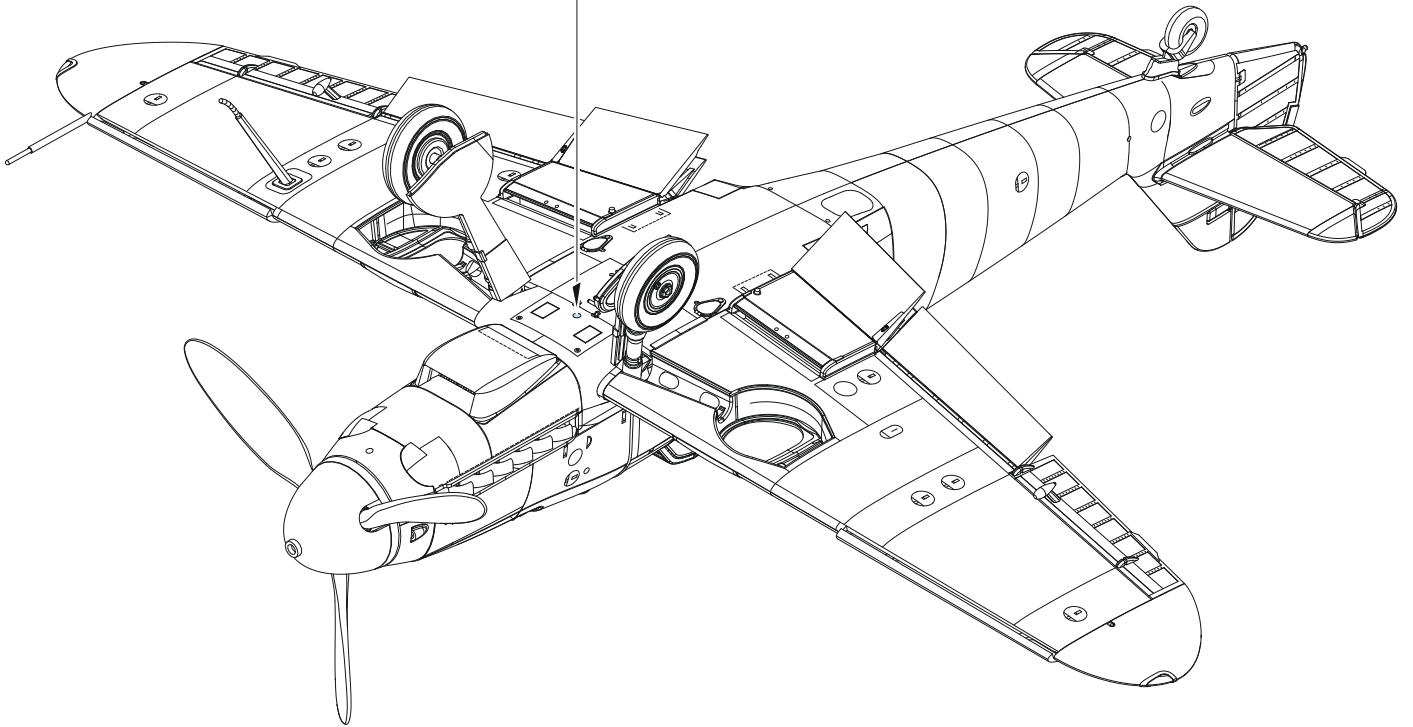
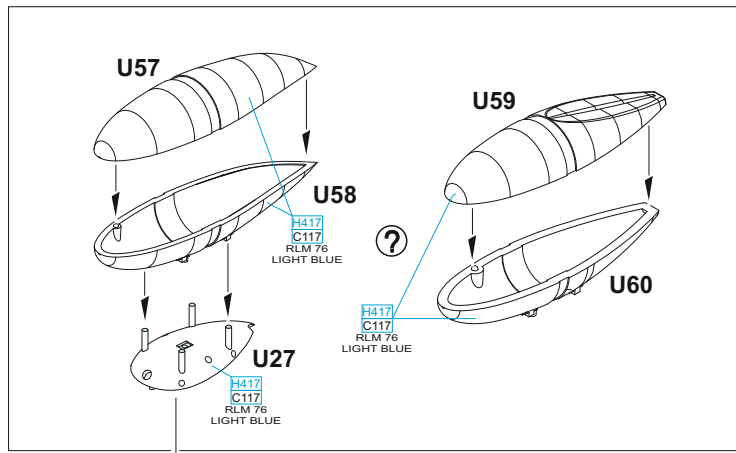

A Bf 109G-10/U4, WNr. 613165, 101. Puma vadászrepülő osztály, Neubiberg, Germany, May 1945

In the end of May 1945, the remaining Hungarian air units were concentrated on the Tulln airport in Austria from where they flew the missions over Wien and Brno areas. On April 5, when the frontline approached Tulln, these units transferred to the Raffelding airfield from where they continued to fly sorties to support the ground units around Wien. At the end of war the Hungarian aviators, same as their German colleagues, preferred to surrender to the US Army, therefore, on May 8, 1945, 101. osztály pilots flew the remaining aircraft over to the Bavarian Neubiberg. The aircraft manufactured in the Diana factory were camouflaged with the same colors as the aircraft manufactured in Wiener Neustadt. The photographs of black 16 show that the Hungarian national insignias were spray-painted directly on the camouflage, the German markings were not applied at all.

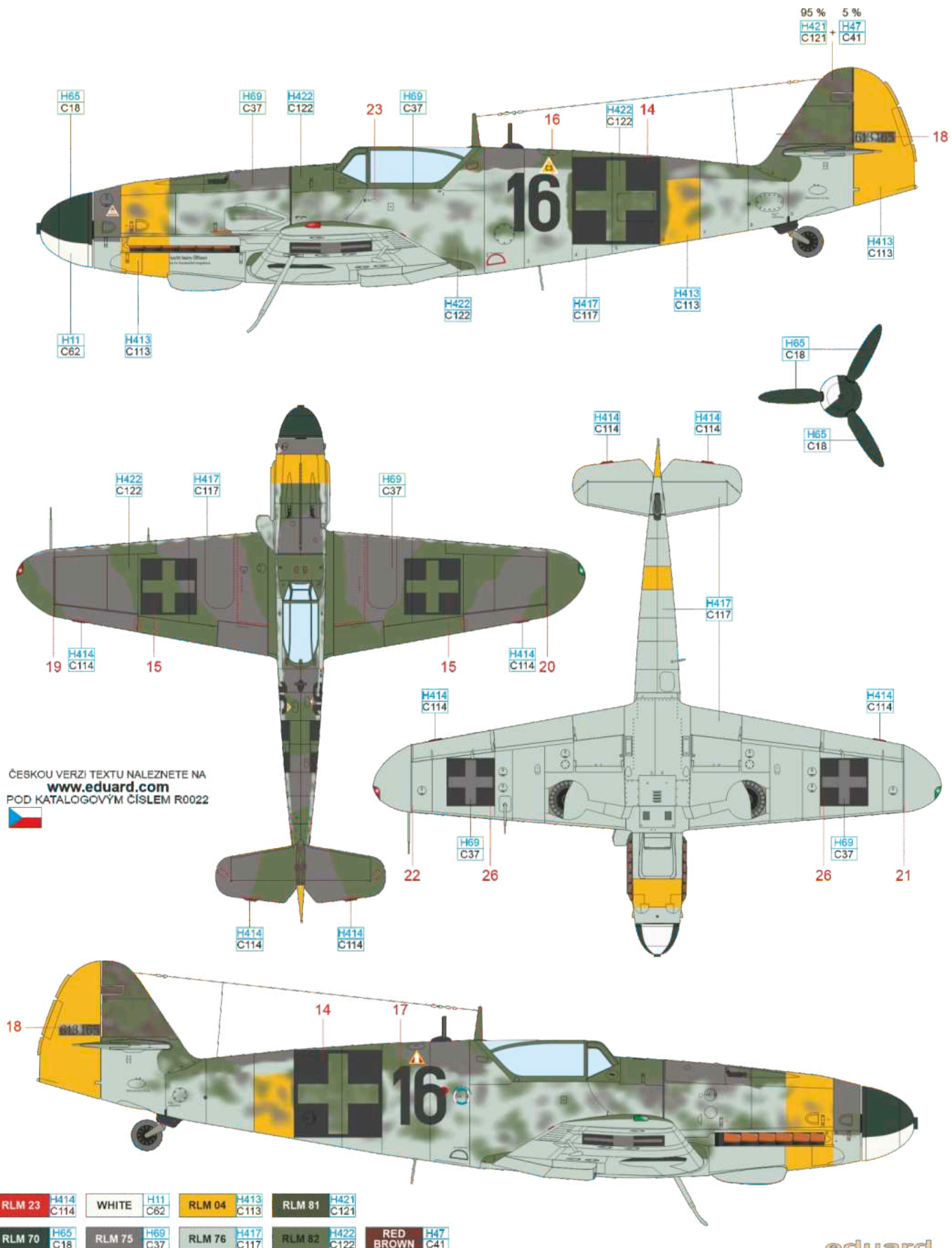

B Bf 109G-10/U4, II./JG 52, Brno, Protectorate of Bohemia and Moravia, April 1945

In the final weeks of fighting in Austria and Moravia in the spring of 1945, Luftwaffe fighter units were also being disbanded in this part of the European battlefield. First, II./JG 51 was disbanded on April 12, and five days later, the same fate afflicted I./JG 53. The aircraft marked White 11 (produced in the Wiener Neustädter Flugzeugwerke factory) was transferred to 7./JG 52, commanded by Heinz Ewald. The Messerschmitt had the inscription *Rosemarie* under the cockpit and sported repainted insignia of JG 53 and II./JG 51. Ofw. Richter flew White 11 into American captivity at Neubiberg on May 8, 1945, although he was not member of II./JG 52. Heinz Ewald was released from American captivity in Fürstenfeldbruck on June 22, 1945.

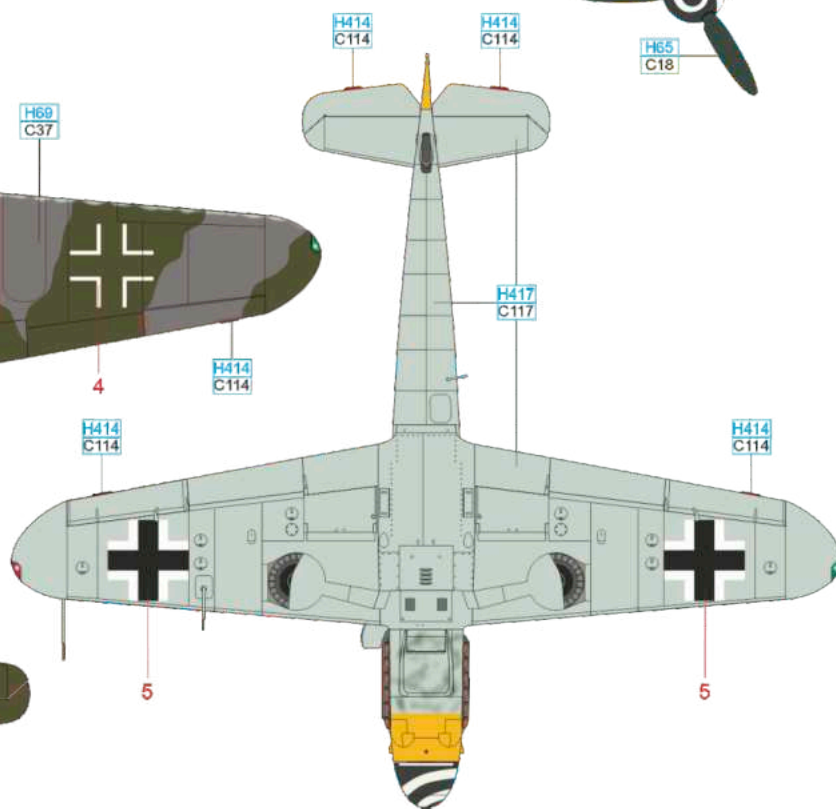
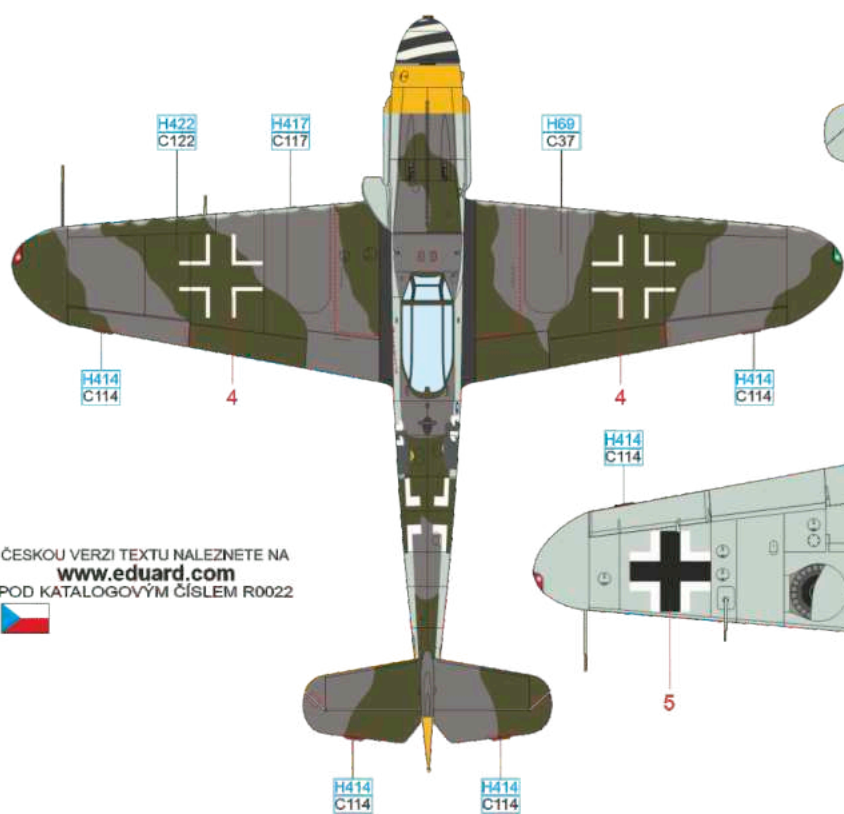
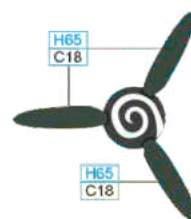
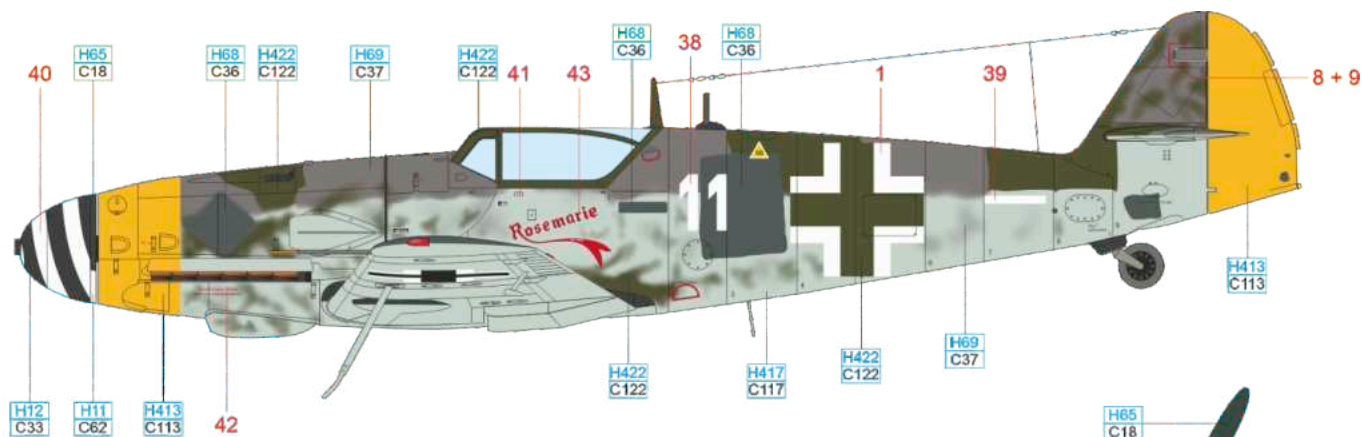

ČESKOU VERZI TEXTU NALEZNETE NA
www.eduard.com
 POD KATALOGOVÝM ČÍSLEM R0022

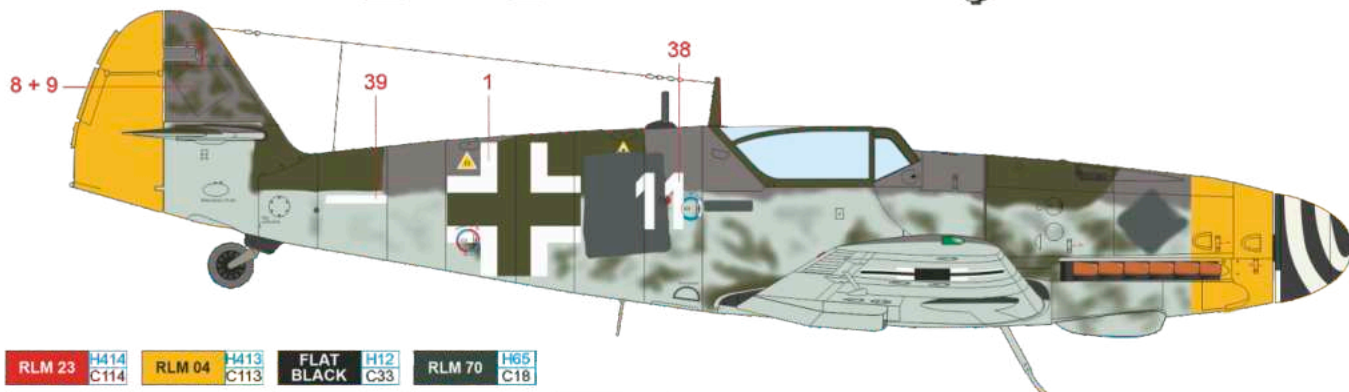

RLM 23	H414 C114	RLM 04	H413 C113	FLAT BLACK	H12 C33	RLM 70	H65 C18
RLM 82	H422 C122	RLM 76	H417 C117	RLM 75	H69 C37	RLM 74	H68 C36
				WHITE	H11 C62		

C Avia S-99, Police Air Patrol Unit, Czechoslovak Police Air Force, Prague-Kbely, 1947

This aircraft, allocated to the air detachment of SNB (Sbor národní bezpečnosti - National Security Corps) got to the air for the first time in summer 1946. The upper and side surfaces were camouflaged in steel grey paint, the lower surfaces were sprayed in darker grey color. The engine cowlings, wings leading edges and elevators of the SNB Air Patrol aircraft were painted in scarlet red. The code letters were painted in the same color outlined in white. The national insignia was in the form of white outlined spherical triangle. The vertical tail stabilizer carried a small black numeral 4.

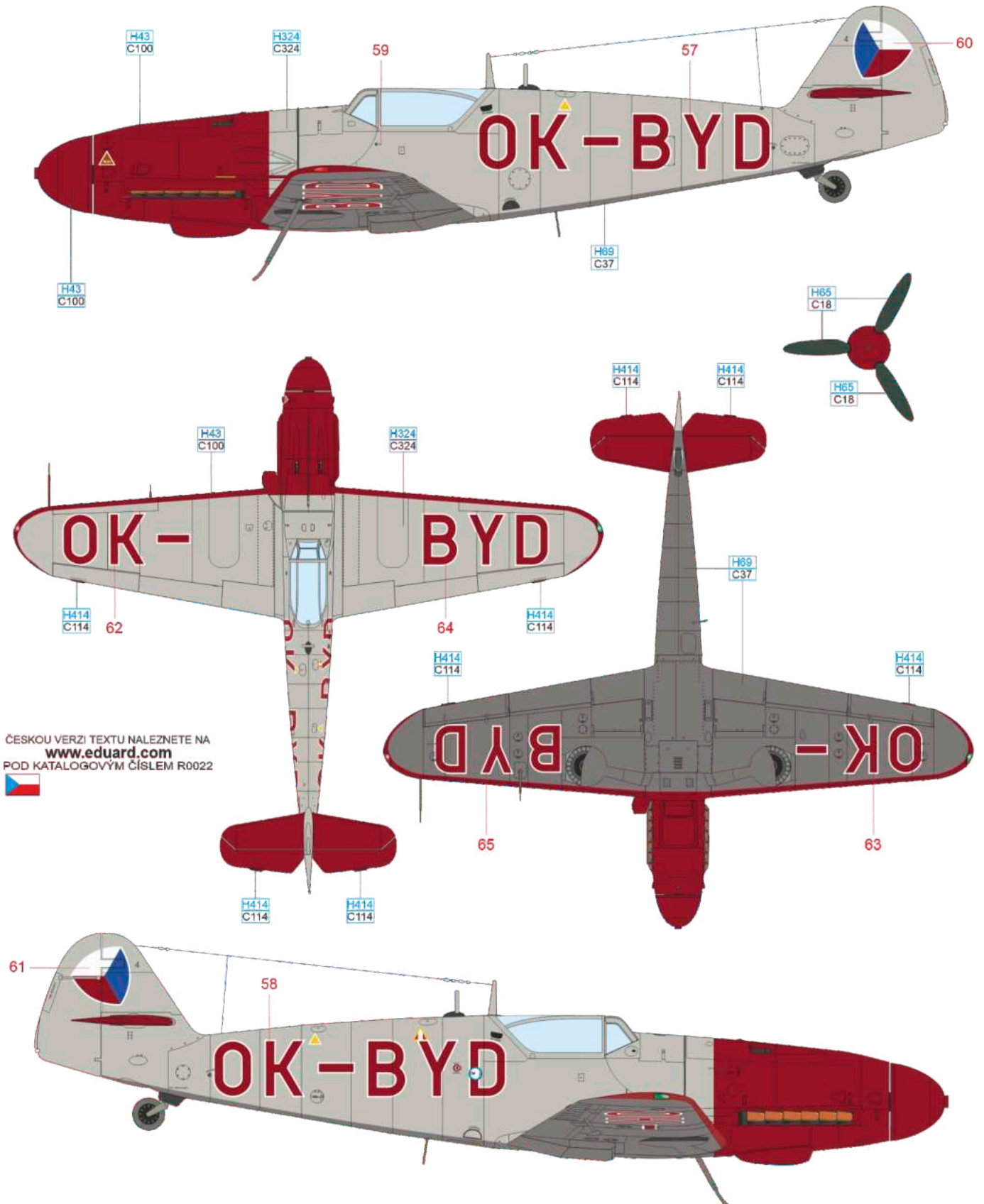

ČESKOU VERZI TEXTU NALEZNETE NA
www.eduard.com
 POD KATALOGOVÝM ČÍSLEM R0022



LIGHT GRAY	H324 C324	RLM 75	H69 C37	WHITE	H43 C100	RLM 70	H65 C18	RLM 23	H414 C114
------------	-----------	--------	---------	-------	----------	--------	---------	--------	-----------

D Bf 109G-10, 1./KG(J) 6, Prague-Kbely, Protectorate of Bohemia and Moravia, March/April 1945

The huge losses suffered by Luftwaffe fighter units were one of the reasons that led in October 1944 to the decision to reduce the number of bomber assets and to distribute their personnel among fighter squadrons following the necessary conversion training. One of the Geschwader units affected by this change was KG 6. The unit was redesignated as KG(J) 6 and was re-equipped with the Bf 109G-10s and K-4s. Training was undertaken at Prague-Kbely, Prague-Ruzyně and also at Klecany airfields. On March 31, KG(J) 6 aircraft fought against 309th FS/31st FG Mustangs over Prague. The resulting heavy losses led to the disbandment of the unit a few days later, on April 9. This aircraft, manufactured at the Messerschmitt factory in Regensburg, was abandoned at Kbely, probably due to irreparable damage, where it was photographed after the war. The KG(J) 6 ownership was indicated by the red and black chessboard band on the rear part of the fuselage.

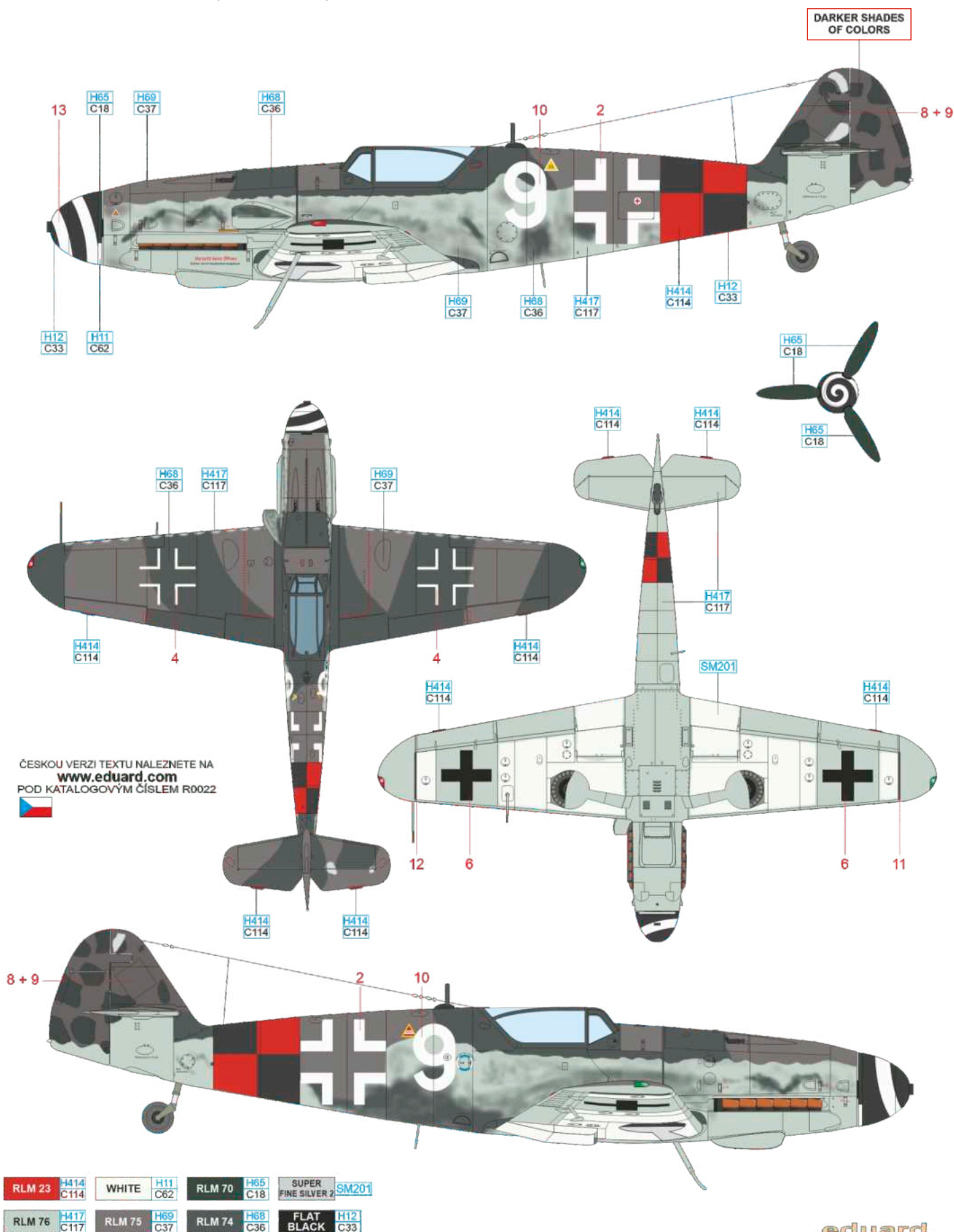

ČESKOU VERZI TEXTU NALEZNETE NA
www.eduard.com
 POD KATALOGOVÝM ČÍSLEM R0022



RLM 23	H414 C114	WHITE	H11 C62	RLM 70	H65 C18	SUPER FINE SILVER 2	SM201
RLM 76	H417 C117	RLM 75	H69 C37	RLM 74	H68 C36	FLAT BLACK	H12 C33

E Bf 109G-10, 13./JG 27, Schleswig-Holstein, Germany, March 1945

After the Allied landings in Normandy in early June 1944, IV. Gruppe JG 27 moved from Hungary to the French airfield of Champfleury-la-Perthe and began their participation in combat on the Western Front. After suffering heavy losses, the unit went to Lower Saxony for rest and replenishment. The unit was assigned to the Defense of the Reich system and was disbanded on March 31, 1945. Pilots and personnel were distributed among the other units of JG 27. The white wave marking on the rear fuselage identified this aircraft, manufactured at the Messerschmitt factory in Regensburg, as being assigned to the IV. Gruppe, and the green band was recognition marking of the Defense of the Reich unit JG 27.

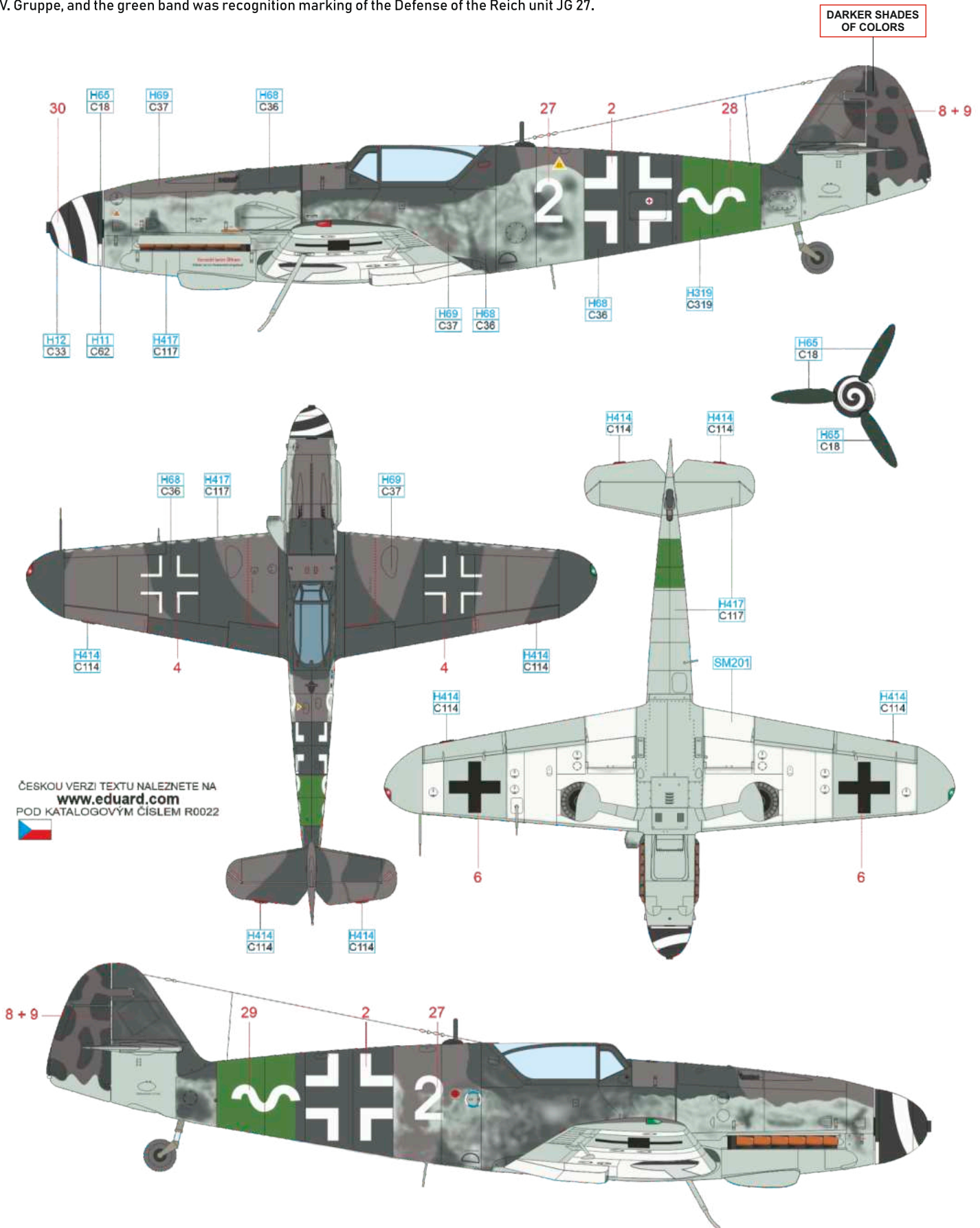

ČESKOU VERZI TEXTU NALEZNETE NA
www.eduard.com
 POD KATALOGOVÝM ČÍSLEM R0022



RLM 23	H414 C114	LIGHT GREEN	H319 C319	WHITE	H11 C62	FLAT BLACK	H12 C33
RLM 76	H417 C117	RLM 75	H69 C37	RLM 74	H68 C36	RLM 70	H65 C18
						SUPER FINE SILVER 2	SM201

F Bf 109G-10, Hptm. Erich Hartmann, CO of I./JG 52, Görlitz, Germany, April 1945

Erich Hartmann, the most successful fighter pilot of all times, first joined the 7. Staffel of JG 52 on October 10, 1942. He stayed with Jagdgeschwader 52 till the end of the World War Two; in fact, he became the commander of its I. Gruppe. The total count of his victories was 352. For his exceptional success he was awarded the Knight's Cross of the Iron Cross with Oak Leaves, Swords and Diamonds. After WWII he was transferred to the POW camp in the Ural Mountains in Soviet Union and was not released until 1955. The following year he joined the ranks of Western German Luftwaffe. He became commander of JG 71, the first Luftwaffe squadron equipped with jet-powered fighter aircraft. He retired in 1970 and died on September 20, 1993. Hartmann's aircraft, manufactured at the Erla factory in Leipzig, carried a black tulip marking outlined in white on the nose. Below the cockpit on the left side there was a heart painted with the name of Hartmann's wife. The Gruppe leader marking took the shape of a double wedge, but only as a white outline.

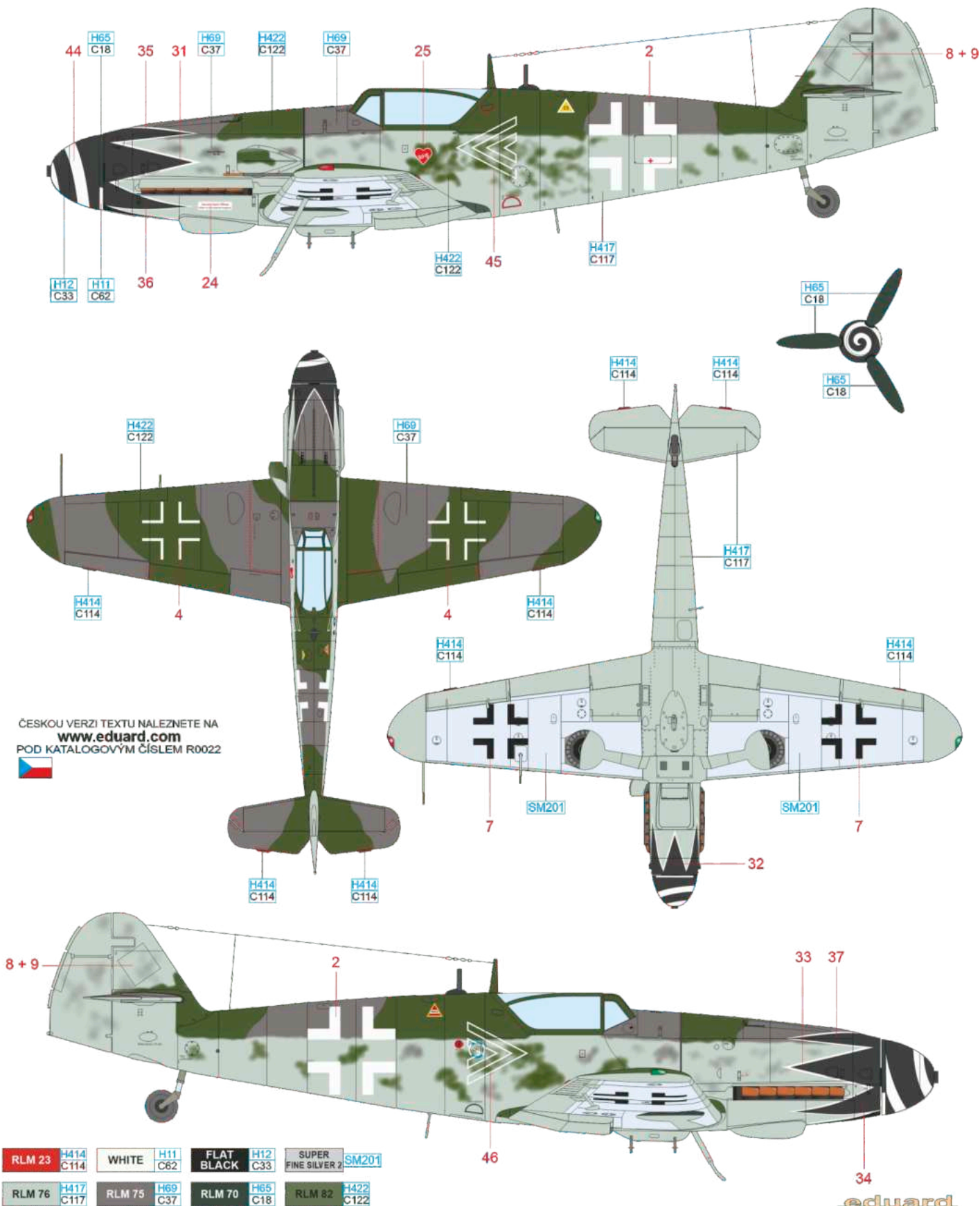

H Bf 109G-10, WNr. 152xx6, 11./JG 300, Prague-Kbely, Czechoslovakia, May 1945

The aircraft found in front of the hangar at Prague-Kbely airport in the end of war comes from the production series 152xxx produced in Erla factory in Leipzig. The aircraft from this manufacturing batch had wings featuring larger bulges enabling the installation of the larger wheels i.e., the same type used on Bf 109G-10 planes manufactured at WNF factory and it's Diana branch. The fuselage and wings were probably spray painted in RLM 81/82 colors even though some researchers incline towards a single color camouflage variation sprayed in RLM 81. The wing lower surfaces were not painted at all with the exemption of parts coming from subcontractors which were painted in RLM 76. The engine cowling, coming from a different airframe, is camouflaged in RLM 74/75/76 colors. Of the serial number painted on the vertical tail surface only first three digits (152) and the last one (6) are legible.

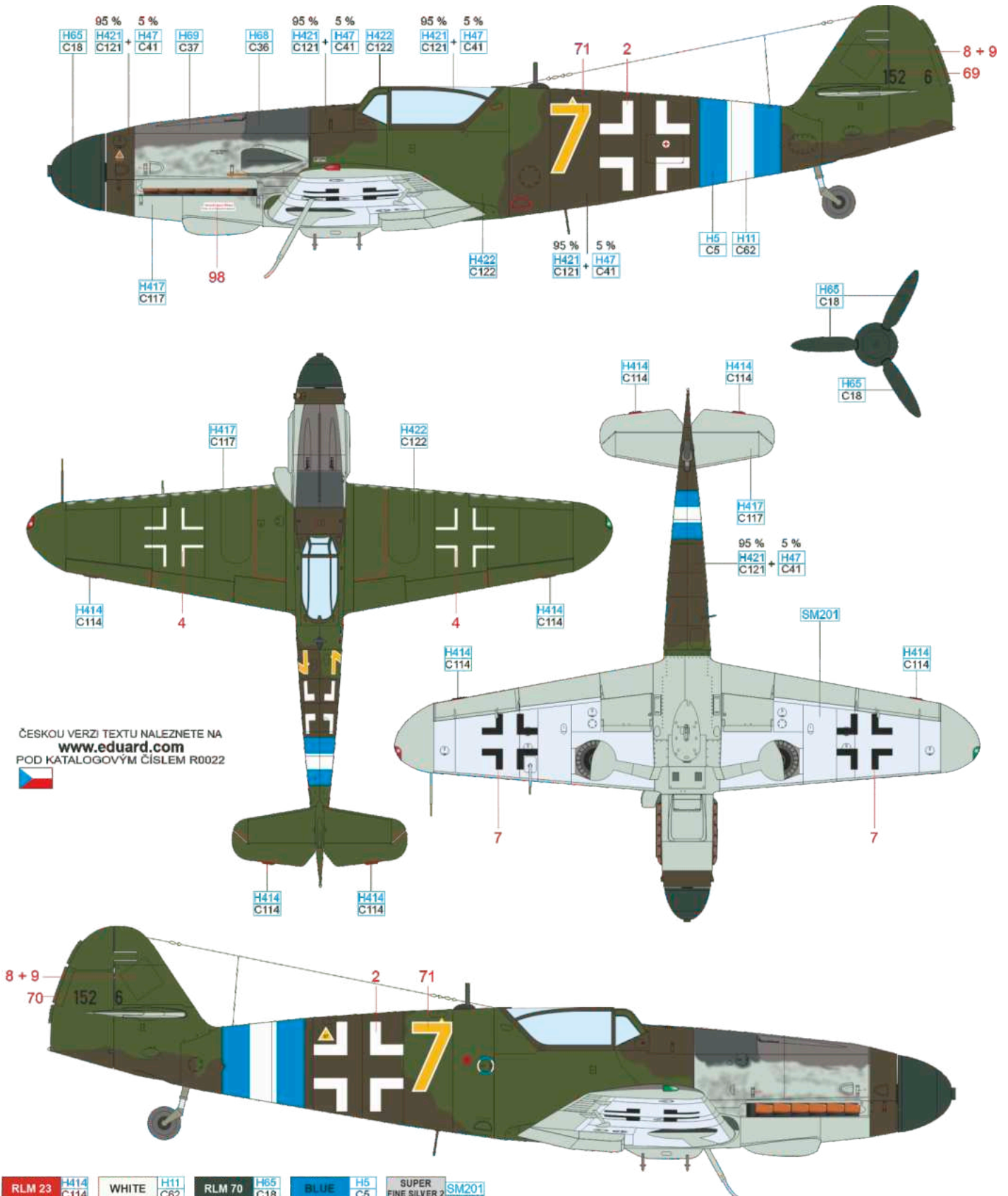

ČESKOU VERZI TEXTU NALEZNETE NA
www.eduard.com
 POD KATALOGOVÝM ČÍSLEM R0022



RLM 23	H414 C114	WHITE	H11 C62	RLM 70	H65 C18	BLUE	H5 C5	SUPER FINE SILVER 2	SM201		
RLM 76	H417 C117	RLM 75	H69 C37	RLM 74	H68 C36	RLM 81	H421 C121	RLM 82	H422 C122	RED BROWN	H47 C41

One of the last established Luftwaffe units was Jagdgeschwader 6 established in July 1944. Its Stab plus I. and II. Gruppe were activated in Königsberg (nowadays Kaliningrad) and equipped with Fw 190A fighters. Its III. Gruppe was established in October 1944 by re-naming I./JG 5 and equipped with Messerschmitts Bf 109G. On January 1, 1945, the entire unit took part in the operation Bodenplatte, an attack of the fighter units on the Allied airports located on the liberated territories of the Western Europe. Bf 109G-14/AS marked Green 1 was photographed in May 1945 at the airport in Twente. It was reported that it had probably landed here due to the engine failure on its return from the operation Bodenplatte. JG 6 aircraft typically carried red-white-red markings on the rear fuselage, this particular aircraft sported only 2 bands.

