



**Spektrum Firma 40 Amp Brushed  
SMART ESC with Receiver**

---

**Spektrum Firma 40 A gebürsteter SMART-  
Geschwindigkeitsregler mit Empfänger**

---

**Variateur ESC SMART à balais  
Spektrum Firma 40 AMP avec récepteur**

---

**SMART ESC a spazzole Spektrum  
Firma 40 Amp con Ricevitore**

---

**HORIZON**  
H O B B Y



**SPEKTRUM**®

## NOTICE

All instructions, warranties and other collateral documents are subject to change at the sole discretion of Horizon Hobby, LLC. For up-to-date product literature, visit [horizonhobby.com](http://horizonhobby.com) or [towerhobbies.com](http://towerhobbies.com) and click on the support or resources tab for this product.

## Meaning of Special Language

The following terms are used throughout the product literature to indicate various levels of potential harm when operating this product:

**WARNING:** Procedures, which if not properly followed, create the probability of property damage, collateral damage, and serious injury OR create a high probability of superficial injury.

**CAUTION:** Procedures, which if not properly followed, create the probability of physical property damage AND a possibility of serious injury.

**NOTICE:** Procedures, which if not properly followed, create a possibility of physical property damage AND a little or no possibility of injury.



**WARNING:** Read the ENTIRE instruction manual to become familiar with the features of the product before operating. Failure to operate the product correctly can result in damage to the product, personal property and cause serious injury.

This is a sophisticated hobby product. It must be operated with caution and common sense and requires some basic mechanical ability. Failure to operate this Product in a safe and responsible manner could result in injury or damage to the product or other property. This product is not intended for use by children without direct adult supervision. Do not attempt disassembly, use with incompatible components or augment product in any way without the approval of Horizon Hobby, LLC. This manual contains instructions for safety, operation and maintenance. It is essential to read and follow all the instructions and warnings in the manual, prior to assembly, setup or use, in order to operate correctly and avoid damage or serious injury.

**Age Recommendation: Not for children under 14 years.  
This is not a toy.**

**NOTICE:** This product is only intended for use with unmanned, hobby-grade, remote-controlled vehicles and aircraft. Horizon Hobby disclaims all liability outside of the intended purpose and will not provide warranty service related thereto.

## Waterproof Component

---

Your new Horizon Hobby® Spektrum™ 40A Brushed Waterproof 2-in-1 ESC and Receiver has been designed and built to allow you to operate the product in many “wet conditions”, including puddles, creeks, wet grass, snow and even rain.

While waterproof, this component has not been designed to be immersed in water for long periods of time and should NOT be treated like a submarine. In addition, most metal parts, including any screws and nuts, as well as the contacts in the electrical cables, will be susceptible to corrosion if additional maintenance is not performed after running in wet conditions.

To maximize the long-term performance of your ESC and to keep the warranty intact, it should only be used as described in the “Usage Conditions” section of this manual. Additionally, the procedures described in the “Wet Conditions Maintenance” section must be performed regularly if you choose to run in wet conditions. If you are not willing to perform the additional care and maintenance required, then you should not operate your vehicle in those conditions.



**CAUTION:** Failure to exercise caution while using this product and comply with the following precautions could result in product malfunction and/or void the warranty.

### General Precautions

- Read through the wet conditions maintenance procedures and make sure that you have all the tools you will need to properly maintain your ESC.
- Do not operate your ESC where it could come in contact with salt water (ocean water or water on salt-covered roads), contaminated or polluted water. Salt water is very conductive and highly corrosive, so use caution.

## Usage Conditions

Your ESC will operate successfully in any of the following, individual-usage scenarios:

- 2 hours continuous operation in damp grass or vegetation.
- 2 hours continuous operation in heavy fog (95% humidity, saturated air, condensing water).
- 1 hour continuous operation in light rain (<0.10 in/2.5mm per hour).
- 15 minutes continuous operation in heavy rain (>0.30 in/7.6mm per hour).
- 1 hour continuous operation in light sleet (<0.10 in/2.5mm per hour).
- 1 hour continuous operation in light snow (<0.25 in/6.35mm per hour).
- 45 minutes continuous operation in standing or running fresh water (the water level should always remain below the vehicle frame), or constant splashing water, without any immersion of waterproof component(s).
- 5 minutes continuous operation in standing or running fresh water (the water level should never rise higher than 0.5 in (about 10mm) above the vehicle frame), constant splashing water, or frequent, intermittent immersion of waterproof component(s).
- 1 hour continuous operation in damp sand, dirt, mud or snow (the material level should always be below the vehicle frame), constant splatter without any immersion or coverage of waterproof component(s).

Furthermore, when appropriate maintenance procedures (as described below) are performed promptly following exposure, the ESC will remain best protected from corrosion or other long-term, water-related damage.

## Wet Conditions Maintenance

- Gently rinse the mud and dirt off the ESC with a garden hose.
- Remove the battery pack(s) and dry the contacts.
- If you have an air compressor or a can of compressed air available, blow off the ESC to help remove any water that may have gotten into small crevices or corners. Dry any water that may be inside a recessed connector housing.
- Let the ESC air dry before you store it. Water may continue to seep or evaporate out of tight areas for a few hours.

**NOTICE:** Never use a pressure washer to clean your vehicle.

# Contents

---

Specifications .....	7
Diagram .....	8
Installation .....	9
Binding.....	9
ESC and Transmitter Calibration .....	10
Operation .....	10
Failsafe .....	10
Programming and Update Ports .....	11
ESC Programming.....	11
Programmable Features .....	12
Receiver Firmware Updates .....	14
LED Indicators .....	15
Receiver Troubleshooting Guide .....	16
Telemetry Troubleshooting Guide.....	17
ESC Troubleshooting Guide.....	17
1-YEAR LIMITED WARRANTY .....	19
Warranty and Service Contact Information .....	23
FCC Information.....	23
Compliance Information for Canada.....	24
Compliance Information for the European Union.....	25

## Features

---

### **Firma 40 Amp Brushed SMART ESC with Receiver**

This ESC and receiver combination is compatible with Spektrum DSM2®/DSMR® surface transmitters, and includes built-in SMART telemetry. Use a Spektrum transmitter with SMART compatible telemetry to view ESC and battery data.

An update may be required for your transmitter for SMART features, see [SpektrumRC.com](http://SpektrumRC.com) for more information.

There are three servo ports (Steering, Aux 1, Aux 2). The throttle is internally connected to the ESC and does not have a servo port.

There are no telemetry ports, all telemetry features are integrated.

<b>Specifications</b>	<b>SPMXSE1040RX</b>
Type	Waterproof DSMR ESC/Receiver 2-in-1 with SMART Telemetry
Dimensions (L × W × H)	54mm × 33.5mm × 20.5mm
Antenna Length	31mm
Channels	4 (No Throttle Servo Output)
Weight	68g
Band	2404 MHz – 2476 MHz
Servo Output Voltage	6V up to 3A, Shared with Auxiliary Light Connectors
Telemetry Features	Battery Voltage, Current, ESC Temp, Battery Data (with SMART Battery)
Battery Input Connector	IC3™ (EC3™ Compatible)
Voltage Range	2–3S Li-Po*/5–9S NiMH
Max Current	40A Continuous/ 180A Burst
Motor Connectors	3.5mm Bullet
Compatible Motors (Based on Battery Voltage)	Brushed Below 8.4V; Down to 12T Below 12.6V; Down to 30T

\*Default setting for low voltage cutoff is Li-Po. Optional Dynamite DYN3005 Program Card required to change the Battery Type Setting.

## Diagram

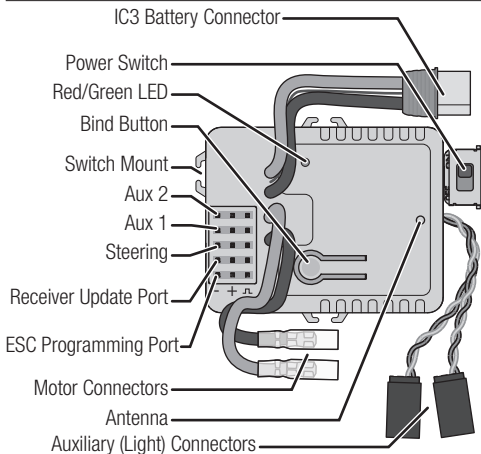

**NOTICE:** Always disconnect the battery from the ESC when you have finished operating your vehicle. If you leave the battery connected with the power switch in the OFF position, the ESC will continue to draw current when connected to the battery, resulting in possible damage to the battery through over-discharge.

**NOTICE:** Do not connect a dedicated receiver battery to the servo or programming ports. When the ESC/Receiver is turned On it will provide the servo ports with 6V regulated power from the main battery. If a dedicated receiver battery is connected to the servo ports, the ESC/receiver may be damaged.

## Installation

---

1. Determine how to mount the ESC/Receiver as specified by your vehicle's instruction manual, or in an area with adequate airflow and protection from damage. Ensure all wiring connections can be reached prior to mounting. For the best reception performance choose a mounting arrangement that will put the antenna as high as possible in the vehicle, away from metal or carbon fiber.
2. Use double-sided foam tape on the bottom of the case to secure the ESC/Receiver in position.
3. Connect the red power connectors together and the black power connectors together between the ESC and the motor.
4. If you need to reverse the motor direction you can reverse the power connections between the motor and ESC.
5. Secure all wiring and ensure the 2-in-1 has good airflow.
6. There is an integrated slide mount on each side of the case for the switch. Choose a mounting position; the switch can be installed on one of the slide mounts, or mounted elsewhere with double-sided foam tape.

**NOTICE:** Do not cut, kink, or modify the antenna. Damage to the antenna or shortening it will reduce the range.

## Binding

---

1. Begin with no battery connected.
2. Press and hold the bind button on the receiver.
3. Throttle should be at neutral to set failsafe. Power ON the receiver. The red LED flashes, indicating the receiver is in bind mode. Release the bind button after the red LED begins to flash. The motor will make continuous descending tones until binding is complete.
4. Put your transmitter in bind mode.
5. The bind process is complete when the green LED on the receiver remains lit.

## **ESC and Transmitter Calibration**

---

1. Begin with no battery connected.
2. Ensure your transmitter is powered ON, the throttle is not reversed, the throttle trim is neutral and the throttle travel range is at 100%. Disable any special functions such as ABS, etc.
3. Keep the throttle at neutral and power ON the ESC.
4. The ESC/Receiver automatically calibrates the throttle range after 3 seconds.
5. The LED will blink and the motor will beep to indicate the battery mode selection.
6. One long LED blink and one long beep will indicate when the ESC is ready to run.

## **Operation**

---

1. Power on the transmitter.
2. Power on the receiver.
3. The green LED on the receiver will be illuminated when it is connected to your transmitter.
4. Disconnect your battery from the ESC/Receiver after operation.

## **Failsafe**

---

In the unlikely event that the radio link is lost during use, the 2-in-1 will drive the throttle channel to the neutral (throttle off) position. If the 2-in-1 is powered on prior to turning on the transmitter, it will enter failsafe mode, leaving throttle off. When the transmitter is turned on, normal control will resume.

## Programming and Update Ports

---

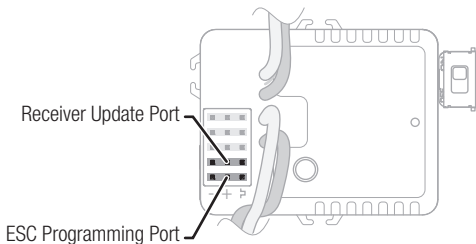

## ESC Programming

---

The ESC portion of the 2-in-1 may be programmed from the optional Dynamite DYNS3005 Program Card.

To change settings with the programming box:

1. Begin with no battery connected.
2. Connect the cable for the programming box into the programming port as shown.
3. Connect a battery and power ON the ESC.
4. Select the programming choices.
5. Power off the ESC.
6. Disconnect the cable for the programming box.

## Programmable Items

---

Optional programming box DYNS3005 required

1. Running mode
2. Battery Type Li-Po/NiMH (Li-Po has Low Voltage Cutoff)
3. Cutoff Voltage
4. Start-up Force (%)
5. Max Forward Force (%)
6. Max Reverse Force (%)
7. Max Brake Force (%)
8. Initial Brake Force (%)
9. Drag Brake (%)
10. Drag Brake Rate Control (Level)
11. Neutral Range (%)
12. Start Mode/Punch (Level)
13. PWM Frequency
14. Freewheeling

## Programmable Values

	1	2	3	4	5	6	7	8	9
1.	Fwd/ Brk	Fwd/ Rev/ Brk	Fwd/ Rev						
2.	Li-Po	NiMH							
3.	Off	Auto (low)	Auto (Med)	Auto (High)					
4.	0	2	4	6	8	10	12	14	16
5.	25	50	75	100					
6.	25	50	75	100					
7.	0	12	25	37	50	62	75	87	100
8.	0	6	12	18	25	31	37	43	50
9.	0	5	10	50	60	70	80	90	100
10.	1	2	3	4	5	6	7	8	9
11.	3	4	5	6	7	8	9	10	12
12.	1	2	3	4	5	6	7	8	9
13.	1K	2K	4K	8K	16K				
14.	On	Off							

Blacked out cells with white text represent the default settings.

ESC can be returned to default settings by pressing "Reset" and then "OK" buttons on the programming box.

## Receiver Firmware Updates

If firmware updates are made available for the receiver side of the 2-in-1, you can install the update yourself. The Spektrum USB programming cable (SPMA3065, not included) and a PC are required for updates. Go to the product page at [SpektrumRC.com](http://SpektrumRC.com) for update information and to register your receiver. Registration is required to download updates.

### Update Process

1. Register your receiver and download the Spektrum programmer and the firmware update for the 2-in-1 (when available).
2. Install the Spektrum programmer on your PC and open the app. Connect the USB programming cable to your PC and allow it to install the drivers.

**NOTICE:** In the programmer app there is an option to power the receiver from the PC. Leave this box checked. **DO NOT connect a power source to the receiver at the same time as the USB cable.**

If the box in the programmer app is checked to power the receiver from the computer, and the USB cable is plugged into the receiver, and a power source is plugged into the receiver, there is a high probability of causing permanent damage to the PC.

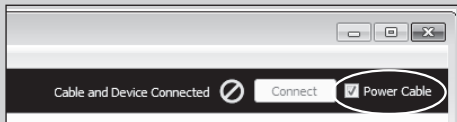

Make sure this check-box is checked to power the receiver from the PC during the update.

3. With the vehicle and receiver powered off, plug the updater cable into the programming port on the 2-in-1. DO NOT turn on the vehicle or receiver when the USB cable is connected. The PC should connect with the receiver automatically.
4. Follow the on screen prompts in the to install the firmware file on the 2-in-1.
5. When the update is complete, unplug the updater cable from the receiver.

## LED Indicators

Upon powering ON the ESC, the red LED will blink and the motor will emit a series of beeps to indicate its status.

The number of tones indicates (1) the ESC is in operation (2) the battery mode detected and (3) the ESC is in a ready-to-use state.

Feature	Red LED Status	Motor Sound
1. ESC Is In Operation	Rapid Blinking	4 Changing Tones
2. Ni-MH/Ni-CD Battery 2S Li-Po Battery 3S Li-Po Battery	1 Blink 2 Blinks 3 Blinks	1 Short Tone 2 Short Beeps 3 Short Beeps
3. ESC Ready No Transmitter Signal	2 Short Blinks Red Blink Repeating	2 Ascending Tones Descending Tones Repeating

DURING OPERATION	LED STATUS
Stop	Green Solid
Forward partial throttle	Green Solid, Red Blinks
Full Throttle	Green and Red Solid
Reverse partial throttle	Green Solid, Red Blinks
Full Throttle	Green and Red Solid
Partial Brake	Green Solid, Red Blinks
Full Brake	Green and Red Solid
Battery Low Voltage or No Signal	Red Blinks
Overheat	Green Blinks
Over Current Protection	Green and Red Triple Blinks

# Receiver Troubleshooting Guide

Problem	Possible Cause	Solution
The system will not connect	Your transmitter and receiver are too close together	Move transmitter 8 to 12 feet away from receiver
	You are near metal objects	Move to an area with less metal
	The receiver is bound to a different model memory	Make sure the correct model memory is active in your transmitter
	Your transmitter was placed into bind mode and is no longer bound to your receiver	Rebind your transmitter and receiver, and then re-calibrate
The receiver goes into failsafe a short distance away from the transmitter	Check for damage on the receiver antenna	Make sure your receiver antenna is protected and located as high as practical
		Replace the receiver or contact Horizon Product Support
The receiver stops responding during operation	Low receiver battery voltage. If the battery voltage is low, it may drop below 3.5V momentarily, causing the receiver to brown-out, then reconnect	Charge the receiver or vehicle battery. Spektrum receivers require at least 3.5V to operate
	Loose or damaged wires or connectors between battery and receiver	Check the wires and connection between the battery and receiver. Repair or replace wires and/or connectors

## Telemetry Troubleshooting Guide

Problem	Possible Cause	Solution
No telemetry options are available in the transmitter	You are using a transmitter that does not include telemetry features	Consider changing to a transmitter which includes telemetry
	Your transmitter is in 5.5ms mode	Select a different DSMR protocol, rebind and then recalibrate
The telemetry screen is blank	The telemetry screen needs to be configured in the transmitter telemetry menu	Configure the telemetry screen

## ESC Troubleshooting Guide

Problem	Possible Cause	Solution
ESC ON - No motor function, audible tone or LED	Battery/connection issue	Recharge/replace battery. Secure all connections
	Damaged ESC/switch	Repair/replace ESC switch/ESC
	Damaged motor	Repair/replace
Motor-Stops and LED blinks	Low voltage protection	When the ESC LED blinks, recharge/replace battery
	Overheat protection	When the LED blinks, let motor/ESC cool, change set up or gearing to avoid overheating
Motor-Accelerates irregularly	Battery issue	Repair damaged wiring/replace battery
	Incorrect gearing	Adjust/replace gearing
	Worn or damaged motor	Repair/replace motor

Motor- Does not turn continuously in response to throttle	ESC/motor damaged	Repair/replace wiring or motor/ESC
Motor- Slows but will not stop	Incorrect transmitter/ESC calibration	Adjust throttle travel/other throttle settings on the transmitter/ESC. Repeat the ESC Calibration Procedure
Steering servo- Operates; motor does not run	Damaged motor	Test the motor apart from the vehicle system, repair/replace motor as needed
	Incorrect transmitter/ESC calibration	Adjust throttle travel/other throttle settings on the transmitter/ESC. Repeat the ESC Calibration Procedure
Steering/ motor- not functioning	Low battery voltage	Recharge/replace
	Wrong model memory selected on transmitter	Select correct model settings on your transmitter, refer to transmitter and/or receiver manual
	Receiver not bound to transmitter	Bind transmitter to receiver, refer to transmitter and/or receiver manual
Vehicle- Does not operate at full speed	Battery issue	Recharge/replace
	Incorrect transmitter/ESC calibration	Adjust throttle travel/other throttle settings on the transmitter/ESC. Repeat the ESC Calibration Procedure

# 1-YEAR LIMITED WARRANTY

---

**What this Warranty Covers** - Horizon Hobby, LLC, (Horizon) warrants to the original purchaser that the product purchased (the "Product") will be free from defects in materials and workmanship for a period of 1 year from the date of purchase.

## **What is Not Covered**

This warranty is not transferable and does not cover (i) cosmetic damage, (ii) damage due to acts of God, accident, misuse, abuse, negligence, commercial use, or due to improper use, installation, operation or maintenance, (iii) modification of or to any part of the Product, (iv) attempted service by anyone other than a Horizon Hobby authorized service center, (v) Product not purchased from an authorized Horizon dealer, (vi) Product not compliant with applicable technical regulations, or (vii) use that violates any applicable laws, rules, or regulations.

OTHER THAN THE EXPRESS WARRANTY ABOVE, HORIZON MAKES NO OTHER WARRANTY OR REPRESENTATION, AND HEREBY DISCLAIMS ANY AND ALL IMPLIED WARRANTIES, INCLUDING, WITHOUT LIMITATION, THE IMPLIED WARRANTIES OF NON-INFRINGEMENT, MERCHANTABILITY AND FITNESS FOR A PARTICULAR PURPOSE. THE PURCHASER ACKNOWLEDGES THAT THEY ALONE HAVE DETERMINED THAT THE PRODUCT WILL SUITABLY MEET THE REQUIREMENTS OF THE PURCHASER'S INTENDED USE.

## **Purchaser's Remedy**

Horizon's sole obligation and purchaser's sole and exclusive remedy shall be that Horizon will, at its option, either (i) service, or (ii) replace, any Product determined by Horizon to be defective. Horizon reserves the right to inspect any and all Product(s) involved in a warranty claim. Service or replacement decisions are at the sole discretion of Horizon. Proof of purchase is required for all warranty claims. SERVICE OR REPLACEMENT AS PROVIDED UNDER THIS WARRANTY IS THE PURCHASER'S SOLE AND EXCLUSIVE REMEDY.

## **Limitation of Liability**

HORIZON SHALL NOT BE LIABLE FOR SPECIAL, INDIRECT, INCIDENTAL OR CONSEQUENTIAL DAMAGES, LOSS OF PROFITS OR PRODUCTION OR COMMERCIAL LOSS IN ANY WAY, REGARDLESS OF WHETHER SUCH CLAIM IS BASED IN CONTRACT, WARRANTY, TORT, NEGLIGENCE, STRICT LIABILITY OR ANY OTHER THEORY OF LIABILITY, EVEN IF HORIZON HAS BEEN ADVISED OF THE POSSIBILITY OF SUCH DAMAGES. Further, in no event shall the liability of Horizon exceed the individual price of the Product on which liability is asserted. As Horizon has no control over use, setup, final assembly, modification or misuse, no liability shall be assumed nor accepted for any resulting damage or injury. By the act of use, setup or assembly, the user accepts all resulting liability. If you as the purchaser or user are not prepared to accept the liability associated with the use of the Product, purchaser is advised to return the Product immediately in new and unused condition to the place of purchase.

## **Law**

These terms are governed by Illinois law (without regard to conflict of law principals). This warranty gives you specific legal rights, and you may also have other rights which vary from state to state. Horizon reserves the right to change or modify this warranty at any time without notice.

## **WARRANTY SERVICES**

### **Questions, Assistance, and Services**

Your local hobby store and/or place of purchase cannot provide warranty support or service. Once assembly, setup or use of the Product has been started, you must contact your local distributor or Horizon directly. This will enable Horizon to better answer your questions and service you in the event that you may need any assistance. For questions or assistance, please visit our website at [www.horizonhobby.com](http://www.horizonhobby.com), submit a Product Support Inquiry, or call the toll free telephone number referenced in the Warranty and Service Contact Information section to speak with a Product Support representative.

## Inspection or Services

If this Product needs to be inspected or serviced and is compliant in the country you live and use the Product in, please use the Horizon Online Service Request submission process found on our website or call Horizon to obtain a Return Merchandise Authorization (RMA) number. Pack the Product securely using a shipping carton. Please note that original boxes may be included, but are not designed to withstand the rigors of shipping without additional protection. Ship via a carrier that provides tracking and insurance for lost or damaged parcels, as Horizon is not responsible for merchandise until it arrives and is accepted at our facility. An Online Service Request is available at [http://www.horizonhobby.com/content/service-center\\_render-service-center](http://www.horizonhobby.com/content/service-center_render-service-center). If you do not have internet access, please contact Horizon Product Support to obtain a RMA number along with instructions for submitting your product for service. When calling Horizon, you will be asked to provide your complete name, street address, email address and phone number where you can be reached during business hours. When sending product into Horizon, please include your RMA number, a list of the included items, and a brief summary of the problem. A copy of your original sales receipt must be included for warranty consideration. Be sure your name, address, and RMA number are clearly written on the outside of the shipping carton.

**NOTICE: Do not ship LiPo batteries to Horizon. If you have any issue with a LiPo battery, please contact the appropriate Horizon Product Support office.**

## Warranty Requirements

For Warranty consideration, you must include your original sales receipt verifying the proof-of-purchase date. Provided warranty conditions have been met, your Product will be serviced or replaced free of charge. Service or replacement decisions are at the sole discretion of Horizon.

## **Non-Warranty Service**

Should your service not be covered by warranty, service will be completed and payment will be required without notification or estimate of the expense unless the expense exceeds 50% of the retail purchase cost. By submitting the item for service you are agreeing to payment of the service without notification. Service estimates are available upon request. You must include this request with your item submitted for service. Non-warranty service estimates will be billed a minimum of ½ hour of labor. In addition you will be billed for return freight. Horizon accepts money orders and cashier's checks, as well as Visa, MasterCard, American Express, and Discover cards. By submitting any item to Horizon for service, you are agreeing to Horizon's Terms and Conditions found on our website [http://www.horizonhobby.com/content/service-center\\_render-service-center](http://www.horizonhobby.com/content/service-center_render-service-center).

**ATTENTION: Horizon service is limited to Product compliant in the country of use and ownership. If received, a non-compliant Product will not be serviced. Further, the sender will be responsible for arranging return shipment of the un-serviced Product, through a carrier of the sender's choice and at the sender's expense. Horizon will hold non-compliant Product for a period of 60 days from notification, after which it will be discarded.**

10/15

# Warranty and Service Contact Information

Country of Purchase	Horizon Hobby	Contact Information	Address
United States of America	Horizon Service Center (Repairs and Repair Requests)	servicecenter.horizonhobby.com/RequestForm/	2904 Research Rd. Champaign, Illinois, 61822 USA
	Horizon Product Support (Product Technical Assistance)	productsupport@horizonhobby.com.	
		877-504-0233	
	Sales	websales@horizonhobby.com	
800-338-4639			

## FCC Information

### Supplier's Declaration of Conformity

**SPMXSE1040RX**

**Contains FCC ID: BRWWAC01T**

 This device complies with part 15 of the FCC Rules. Operation is subject to the following two conditions: (1) This device may not cause harmful interference, and (2) this device must accept any interference received, including interference that may cause undesired operation.

 **CAUTION:** changes or modifications not expressly approved by the party responsible for compliance could void the user's authority to operate the equipment.

**NOTE:** This equipment has been tested and found to comply with the limits for a Class B digital device, pursuant to part 15 of the FCC Rules. These limits are designed to provide reasonable protection against harmful interference in a residential installation. This equipment generates, uses and can radiate radio frequency energy and, if not installed and

used in accordance with the instructions, may cause harmful interference to radio communications. However, there is no guarantee that interference will not occur in a particular installation. If this equipment does cause harmful interference to radio or television reception, which can be determined by turning the equipment off and on, the user is encouraged to try to correct the interference by one or more of the following measures:

- Reorient or relocate the receiving antenna.
- Increase the separation between the equipment and receiver.
- Connect the equipment into an outlet on a circuit different from that to which the receiver is connected.
- Consult the dealer or an experienced radio/TV technician for help.

Horizon Hobby, LLC

2904 Research Rd.,

Champaign, IL 61822

Email: [compliance@horizonhobby.com](mailto:compliance@horizonhobby.com)

Web: [HorizonHobby.com](http://HorizonHobby.com)

## **Compliance Information for Canada**

---

CAN ICES-3 (B)/NMB-3(B)

Contains IC: 6157A-WAC01T

This device complies with Industry Canada licence-exempt RSS standard(s).

Operation is subject to the following two conditions:

- (1) this device may not cause interference,
- (2) this device must accept any interference, including interference that may cause undesired operation of the device.

## Compliance Information for the European Union

---



### **EU Compliance Statement: SPMXSE1040RX**

Horizon Hobby, LLC hereby declares that this product is in compliance with the essential requirements and other relevant provisions of the RED and EMC Directives.

A copy of the EU Declaration of Conformity is available online at:

<http://www.horizonhobby.com/content/support-render-compliance>

Frequency Band: 2402 - 2478 MHz

Max EIRP: 20dBm

### **Instructions for disposal of WEEE by users in the European Union**



This product must not be disposed of with other waste. Instead, it is the user's responsibility to dispose of their waste equipment by handing it over to a designated collection point for the recycling of waste electrical and electronic equipment. The separate collection

and recycling of your waste equipment at the time of disposal will help to conserve natural resources and make sure that it is recycled in a manner that protects human health and the environment. For more information about where you can drop off your waste equipment for recycling, please contact your local city office, your household waste disposal service or where you purchased the product.



© 2020 Horizon Hobby, LLC. Firma, the Firma Logo, IC3, EC3, DSM2, DSMR, the Smart Technology logo, and the Horizon Hobby logo are trademarks or registered trademarks of Horizon Hobby, LLC.

The Spektrum trademark is used with permission of Bachmann Industries, Inc.

All other trademarks, service marks and logos are property of their respective owners.

US 9,930,567. US 10,419,970.

SPMXSE1040RX

Created 01/2020

63612