



www.axialracing.com

READY-TO-RUN

CAPPA™

1/10TH SCALE ELECTRIC 4WD UNLIMITED TRAIL BUGGY



INSTRUCTION MANUAL
BEDIENUNGSANLEITUNG
MANUEL D'UTILISATION
MANUALE DI ISTRUZIONI

HORIZON®
H O B B Y

NOTICE

All instructions, warranties and other collateral documents are subject to change at the sole discretion of Horizon Hobby, LLC. For up-to-date product literature, visit horizonhobby.com or towerhobbies.com and click on the support or resources tab for this product.

MEANING OF SPECIAL LANGUAGE

The following terms are used throughout the product literature to indicate various levels of potential harm when operating this product:

WARNING: Procedures, which if not properly followed, create the probability of property damage, collateral damage, and serious injury OR create a high probability of superficial injury.

CAUTION: Procedures, which if not properly followed, create the probability of physical property damage AND a possibility of serious injury.

NOTICE: Procedures, which if not properly followed, create a possibility of physical property damage AND a little or no possibility of injury.

 **WARNING:** Read the ENTIRE instruction manual to become familiar with the features of the product before operating. Failure to operate the product correctly can result in damage to the product, personal property and cause serious injury.

This is a sophisticated hobby product. It must be operated with caution and common sense and requires some basic mechanical ability. Failure to operate this Product in a safe and responsible manner could result in injury or damage to the product or other property. This product is not intended for use by children without direct adult supervision. Do not use with incompatible components or alter this product in any way outside of the instructions provided by Horizon Hobby, LLC. This manual contains instructions for safety, operation and maintenance. It is essential to read and follow all the instructions and warnings in the manual, prior to assembly, setup or use, in order to operate correctly and avoid damage or serious injury.

Age Recommendation: Not for children under 14 years. This is not a toy.

SAFETY PRECAUTIONS AND WARNINGS

As the user of this product, you are solely responsible for operating in a manner that does not endanger yourself and others or result in damage to the product or property of others.

This model is controlled by a radio signal subject to interference from many sources outside your control. This interference can cause momentary loss of control, so it is advisable to always keep a safe distance in all directions around your model as this margin will help avoid collisions or injury.

- Never operate your model with low transmitter batteries.
- Always operate your model in open spaces away from full-size vehicles, traffic and people.
- Never operate the model in the street or in populated areas for any reason.
- Carefully follow the directions and warnings for this and any optional support equipment (chargers, rechargeable battery packs, etc.) you use.
- Keep all chemicals, small parts and anything electrical out of the reach of children.
- Never lick or place any portion of the model in your mouth as it could cause serious injury or even death.
- Exercise caution when using tools and sharp instruments.
- Take care during maintenance as some parts may have sharp edges.
- Immediately after using your model, do NOT touch equipment such as the motor, electronic speed control and battery, because they generate high temperatures. You may burn yourself seriously touching them.
- Do not put fingers or any objects inside rotating and moving parts, as this may cause damage or serious injury.
- Always turn on your transmitter before you turn on the receiver in the car. Always turn off the receiver before turning your transmitter off.
- Keep the wheels of the model off the ground when checking the operation of the radio equipment.

 **WARNING AGAINST COUNTERFEIT PRODUCTS:** Always purchase from a Horizon Hobby, LLC authorized dealer to ensure authentic high-quality Spektrum product. Horizon Hobby, LLC disclaims all support and warranty with regards, but not limited to, compatibility and performance of counterfeit products or products claiming compatibility with Spektrum technology.

TABLE OF CONTENTS

Water-resistant Vehicle with Waterproof Electronics	3	vehicle maintenance	9
box Contents	4	AE-5L Forward/reverse ESC with drag brake	10
Required Equipment	4	Troubleshooting.....	10
recommended tools.....	4	Notes.....	11
Getting started checklist.....	5	Limited Warranty.....	12
Vehicle parts.....	5	Warranty and Service Contact Information	12
Charge the vehicle battery.....	6	FCC Information.....	13
Install the transmitter batteries.....	6	IC Information.....	13
Transmitter functions	6	Compliance Information for the European Union	13
Install the vehicle battery.....	7	Exploded Views.....	50
Binding.....	8	Parts Lists.....	54
Range-checking the radio system	8	Electronics	55
Using the DIG transmission.....	8		

WATER-RESISTANT VEHICLE WITH WATERPROOF ELECTRONICS

Your new Horizon Hobby vehicle has been designed and built with a combination of waterproof and water-resistant components to allow you to operate the product in many “wet conditions,” including puddles, creeks, wet grass, snow and even rain.

While the entire vehicle is highly water-resistant, it is not completely waterproof and your vehicle should NOT be treated like a submarine. The various electronic components used in the vehicle, such as the Electronic Speed Control (ESC), servo(s) and receiver are waterproof, however, most of the mechanical components are water-resistant and should not be submerged.

Metal parts, including the bearings, hinge pins, screws and nuts, as well as the contacts in the electrical cables, will be susceptible to corrosion if additional maintenance is not performed after running in wet conditions. To maximize the long-term performance of your vehicle and to keep the warranty intact, the procedures described in the “Wet Conditions Maintenance” section below must be performed regularly if you choose to run in wet conditions. If you are not willing to perform the additional care and maintenance required, then you should not operate the vehicle in those conditions.



CAUTION: Failure to exercise caution while using this product and complying with the following precautions could result in product malfunction and/or void the warranty.

GENERAL PRECAUTIONS

- Read through the wet conditions maintenance procedures and make sure that you have all the tools you will need to properly maintain your vehicle.
- Not all batteries can be used in wet conditions. Consult the battery manufacturer before use. Caution should be taken when using Li-Po batteries in wet conditions.
- Most transmitters are not water-resistant. Consult your transmitter’s manual or the manufacturer before operation.
- Never operate your transmitter or vehicle where lightning may be present.
- Do not operate your vehicle where it could come in contact with salt water (ocean water or water on salt-covered roads), contaminated or polluted water. Salt water is very conductive and highly corrosive, so use caution.
- Even minimal water contact can reduce the life of your motor if it has not been certified as water-resistant or waterproof. If the motor becomes excessively wet, apply very light throttle until the water is mostly removed from the motor. Running a wet motor at high speeds may rapidly damage the motor.
- Driving in wet conditions can reduce the life of the motor. The additional resistance of operating in water causes excess strain. Alter the gear ratio by using a smaller pinion or larger spur gear. This will increase torque (and motor life) when running in mud, deeper puddles, or any wet conditions that will increase the load on the motor for an extended period of time.

WET CONDITIONS MAINTENANCE

- Drain any water that has collected in the tires by spinning them at high speed. With the body removed, place the vehicle upside down and pull full throttle for a few short bursts until the water has been removed.



CAUTION: Always keep hands, fingers, tools and any loose or hanging objects away from rotating parts when performing the above drying technique.

- Remove the battery pack(s) and dry the contacts. If you have an air compressor or a can of compressed air, blow out any water that may be inside the recessed connector housing.
- Remove the tires/wheels from the vehicle and gently rinse the mud and dirt off with a garden hose. Avoid rinsing the bearings and transmission.

NOTICE: Never use a pressure washer to clean your vehicle.

- Use an air compressor or a can of compressed air to dry the vehicle and help remove any water that may have gotten into small crevices or corners.
- Spray the bearings, drive train, fasteners and other metal parts with a water-displacing light oil. Do not spray the motor.
- Let the vehicle air dry before you store it. Water (and oil) may continue to drip for a few hours.
- Increase the frequency of disassembly, inspection and lubrication of the following:
 - Front and rear axle hub assembly bearings.
 - All transmission cases, gears and differentials.
 - Motor—clean with an aerosol motor cleaner and re-oil the bushings with lightweight motor oil.

BOX CONTENTS

- STX3™ 3Ch 2.4GHz FHSS Radio Transmitter (SPMSTX300)
- (4) AA Alkaline batteries
- Capra™ 1.9 Unlimited Trail Buggy RTR
 - 35T Electric Motor (AX31312)
 - SRX300 3CH Receiver (SPMSRX300)
 - S614 Metal Gear Servo 23T WP (SPMS614)
 - AE-5L ESC w/LED Ports and Lights (DYNS2213)

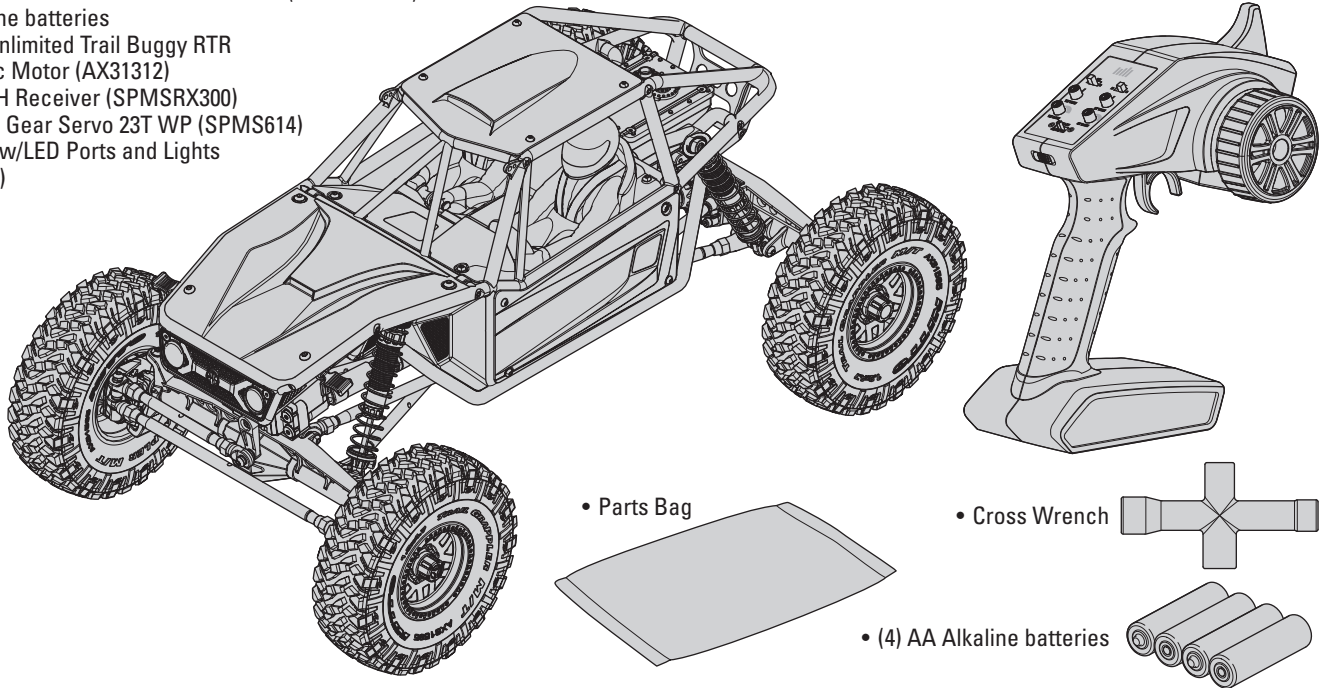

• Parts Bag

• Cross Wrench

• (4) AA Alkaline batteries

REQUIRED EQUIPMENT

- 2-3S Shorty LiPo Battery (96mm maximum width, IC3™ Connector Required)

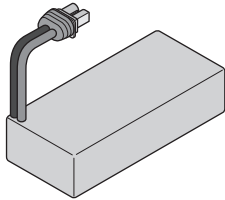

- Battery charger compatible with the chosen vehicle battery

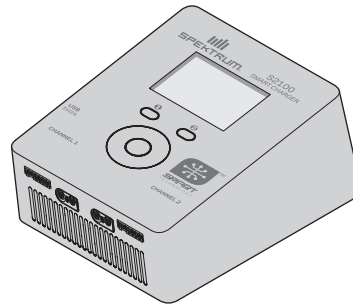

RECOMMENDED TOOLS

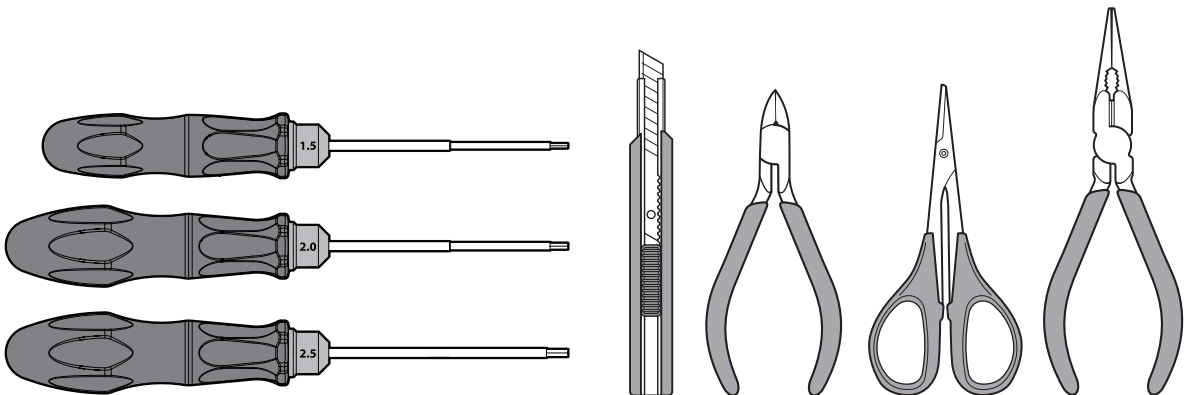

• Hex Drivers (1.5, 2.0, 2.5mm)

• Hobby Knife

• Side Cutter

• Curved Scissors

• Long-nose Plier

GETTING STARTED CHECKLIST

Read the manual
Familiarize yourself with the vehicle and its components
Check all screws, especially the driveshaft setscrews, for tightness from the factory
Charge the vehicle battery
Install 4 AA batteries in the transmitter

Power on the transmitter
Install the vehicle battery in the vehicle
Check for proper function of the throttle and steering
Range check the radio system
Drive the vehicle, challenge yourself and have FUN!
Perform any necessary vehicle maintenance

VEHICLE PARTS

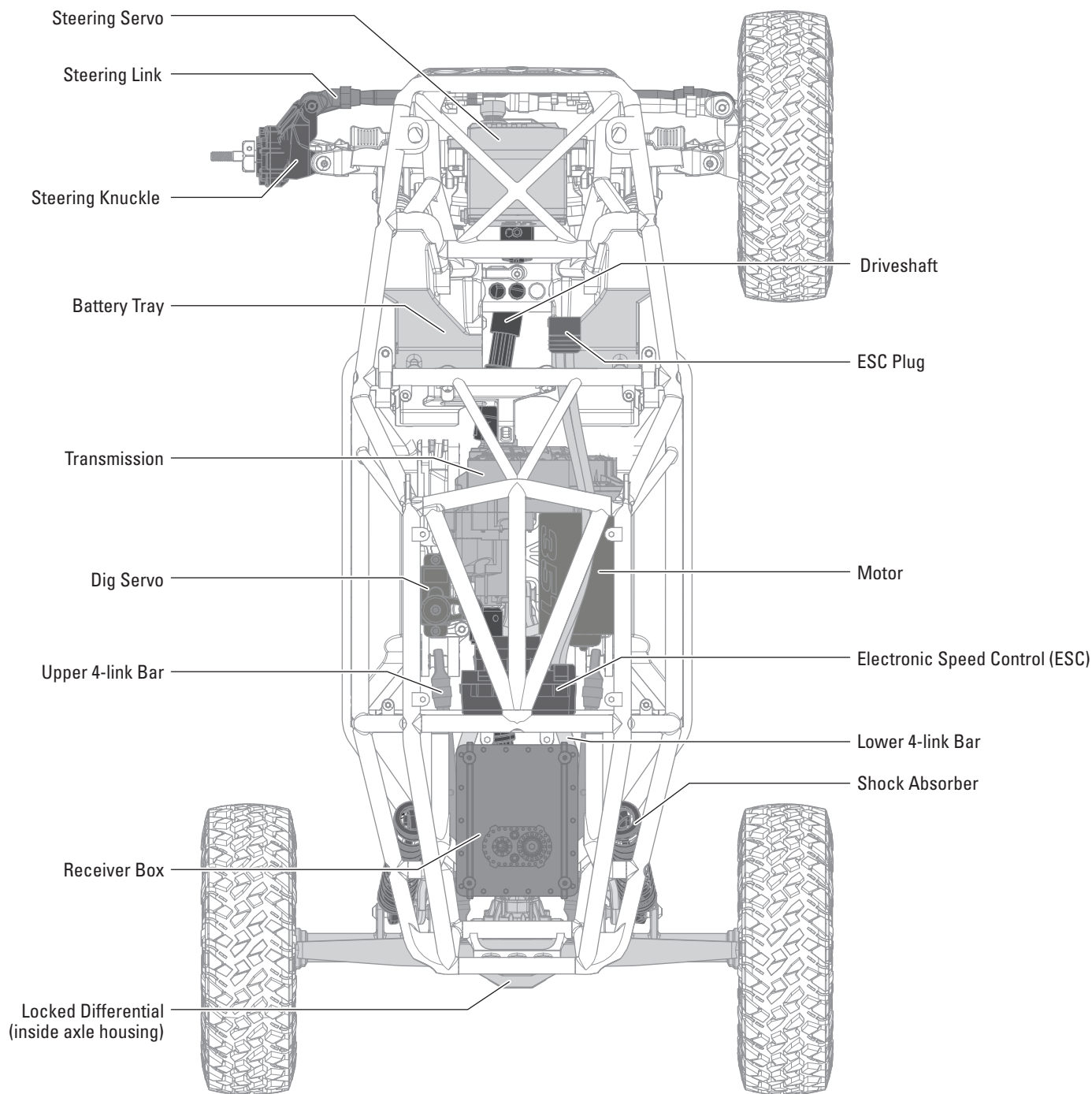

CHARGE THE VEHICLE BATTERY

Follow the manufacturer's directions for your charger to properly charge the vehicle battery.

CAUTION: Only use chargers designed to charge the chosen battery type. Using an incompatible charger or incorrect charge settings could result in fire causing person injury or property damage.

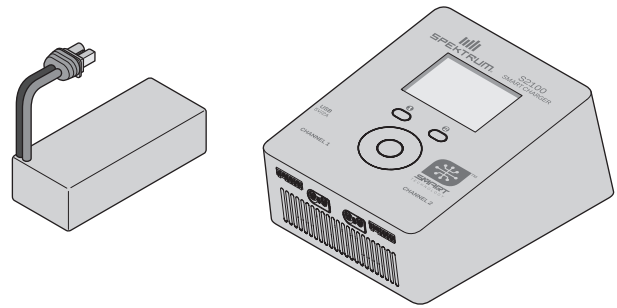

INSTALL THE TRANSMITTER BATTERIES

This transmitter requires 4 AA batteries.

1. Remove the battery cover from the transmitter.
2. Install the batteries as shown.
3. Install the battery cover.

CAUTION: NEVER remove the transmitter batteries while the model is powered on. Loss of model control, damage, or injury may occur.

CAUTION: If using rechargeable batteries, charge only rechargeable batteries. Charging non-rechargeable batteries may cause the batteries to burst, resulting in injury to persons and/or damage to property.

CAUTION: Risk of explosion if battery is replaced by an incorrect type. Dispose of used batteries according to national regulations.

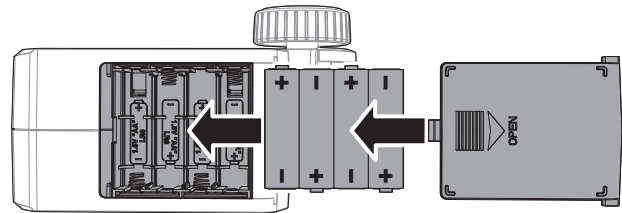

TRANSMITTER FUNCTIONS

A. Servo Reversing

To reverse the Throttle (TH) or Steering (ST) channel, switch the position of the correlating switch—"N" is for normal, "R" is for reverse.

B. Throttle Trim

Adjusts the throttle neutral point

C. Steering Trim

Adjusts the steering center point. Normally, the steering trim is adjusted until the vehicle tracks straight.

D. Throttle Rate

Adjusts the end point of the throttle

E. Steering Rate

Adjusts the end point of the steering

F. Indicator Lights

- Solid red lights: Indicates radio connectivity and adequate battery power
- Flashing red lights: Indicates the battery voltage is critically low. Replace batteries

G. Throttle Limit

Limits throttle output to 50/75/100%

Select 50% or 75% for less experienced drivers or when you are driving the vehicle in a small area.

H. Antenna

I. Power Button

J. Throttle/Brake

K. Steering Wheel

L. Channel 3 Buttons: Top and Bottom

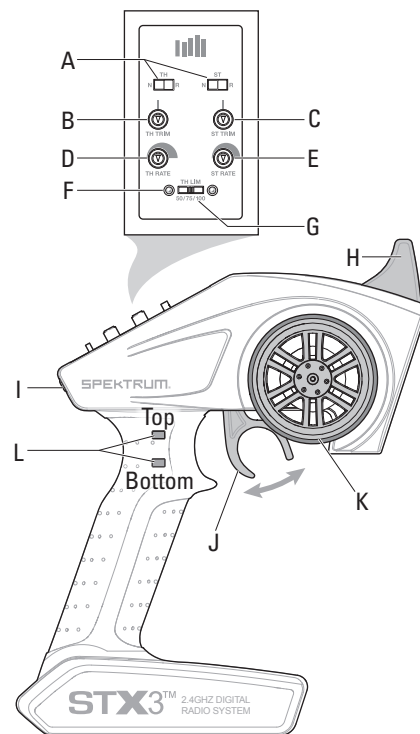

SETTING TRAVEL ENDPOINTS FOR CHANNEL 3

Follow the instructions below to set the travel endpoint of an accessory or servo on channel 3 if needed:

1. Press and hold the CH 3 "Top" button, while powering ON the transmitter. Continue to hold the Top button until the transmitter LED flashes 5 times.
2. Release the Top button
3. Use the CH3 Top and Bottom buttons to adjust the accessory or servo to the desired first end point position.
4. Turn the steering wheel fully clockwise (right) to confirm the first position. The LED will flash once to confirm the first position has been saved.
5. Use the CH3 Top and Bottom buttons to adjust the accessory or servo to the desired second end point position.
6. Turn the steering wheel clockwise (right) to confirm the second position. The LED will flash twice to confirm the second position has been saved.
7. Power off the transmitter to save the settings

INSTALL THE VEHICLE BATTERY

NOTICE: Power to the vehicle is controlled by connecting and disconnecting the battery from the ESC. Always power on the transmitter first before connecting the vehicle battery. Always disconnect the battery from the ESC when not in use.

1. Power on the transmitter.

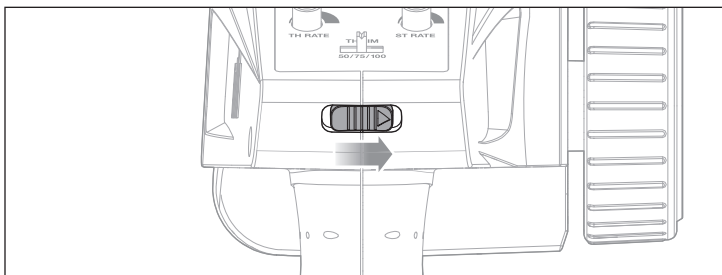

2. Remove the body clips and open the hood.

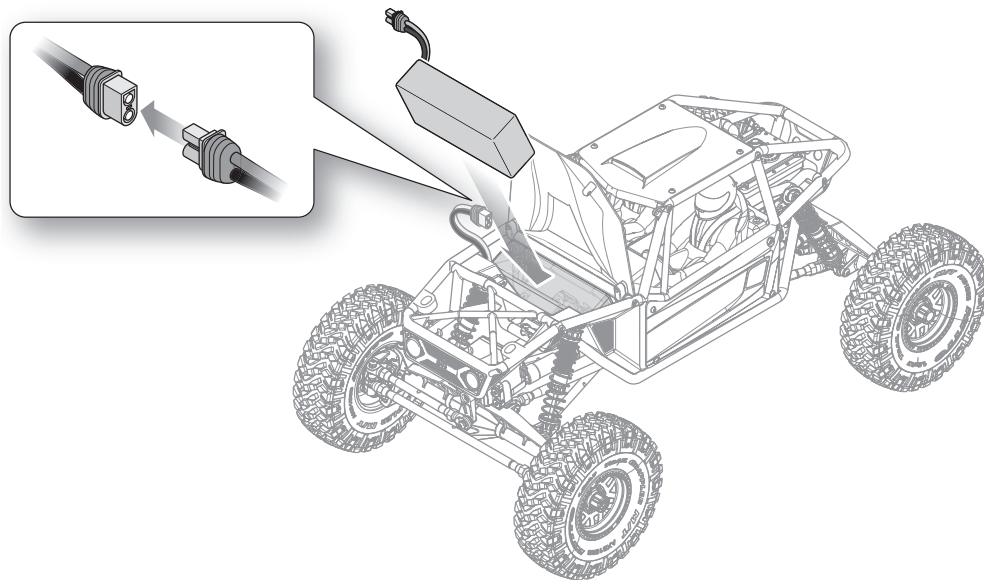
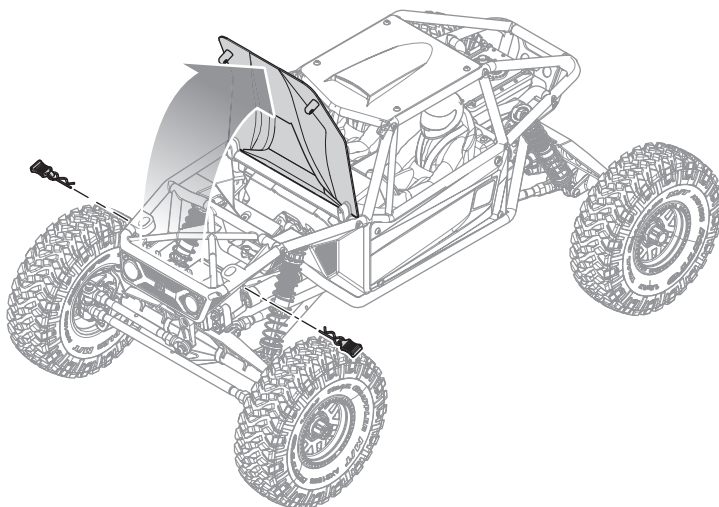

3. Connect the battery to the ESC. Close the hood and replace the body clips.

NOTICE: Always disconnect the battery from the ESC before powering off the transmitter. Powering off the transmitter first may result in loss of control.

BINDING

Binding is the process of programming the receiver to recognize the GUID (Globally Unique Identifier) code of a single specific transmitter. The STX3™ transmitter and SPMSRX300 receiver are bound at the factory. If you need to rebind, follow the instructions below.

1. Insert the bind plug in the BIND port on the receiver.
2. Connect a fully charged battery pack to the ESC.
3. Power on the ESC. The red receiver LED flashes, indicating the receiver is in bind mode.
4. Center the ST TRIM and TH TRIM dials on the transmitter.
5. Turn and hold the steering wheel fully right, then power the transmitter on.
6. When the receiver LED stops flashing, release the steering wheel.
7. Remove the bind plug, then power off the receiver to save the settings.
8. Power off the transmitter.
9. Store the bind plug in a convenient place.

You must rebind when:

- Different failsafe positions are desired e.g., when throttle or steering reversing has been changed.
- Binding the receiver to a different transmitter.

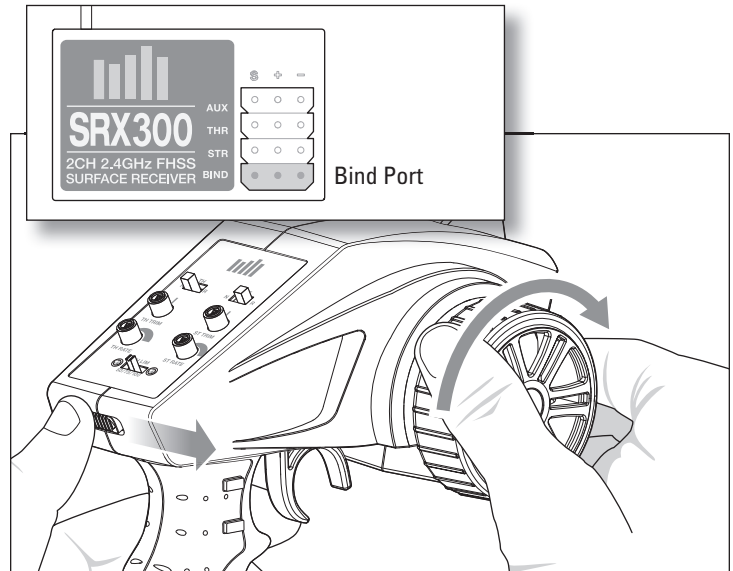

RANGE-CHECKING THE RADIO SYSTEM

The radio system should be checked before operating the vehicle to ensure proper operation and adequate range.

1. Turn on the transmitter.
2. Connect the battery in the vehicle.
3. Have a friend hold the vehicle while keeping hands and loose clothing away from moving parts.
4. Walk away until you are at the maximum planned operating distance from the vehicle.
5. Turn the steering wheel side to side and operate the throttle, both forward and reverse, checking for any erratic behavior.
6. If any erratic behavior is exhibited, DO NOT operate the vehicle. Call customer service for assistance.



USING THE DIG TRANSMISSION

The Axial Capra includes a "Dig" transmission which allows the rear axle to lock while still allowing the front wheels to spin. Use this feature in close quarters to turn the vehicle tighter than is possible with normal 4 wheel drive or to preload the suspension when needed.

To use the Dig function:

1. Press the channel 3 "Top" button on the transmitter. The Dig function engages, locking the rear axle.
2. Advance the throttle and turn the steering wheel left or right to tightly pivot the vehicle around.
3. Press the channel 3 "Bottom" button to disengage the Dig function.

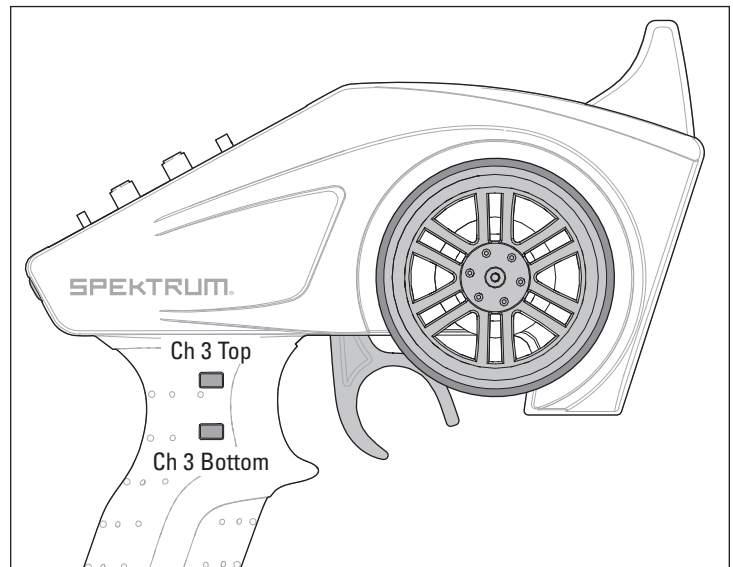

VEHICLE MAINTENANCE

Just like a full size car or truck your RC vehicle must undergo periodic maintenance in order to ensure peak performance. Preventative maintenance will also help avoid needless breakages which could result in costly repairs. Below are some suggestions to properly maintain your vehicle.

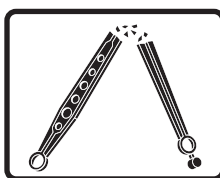
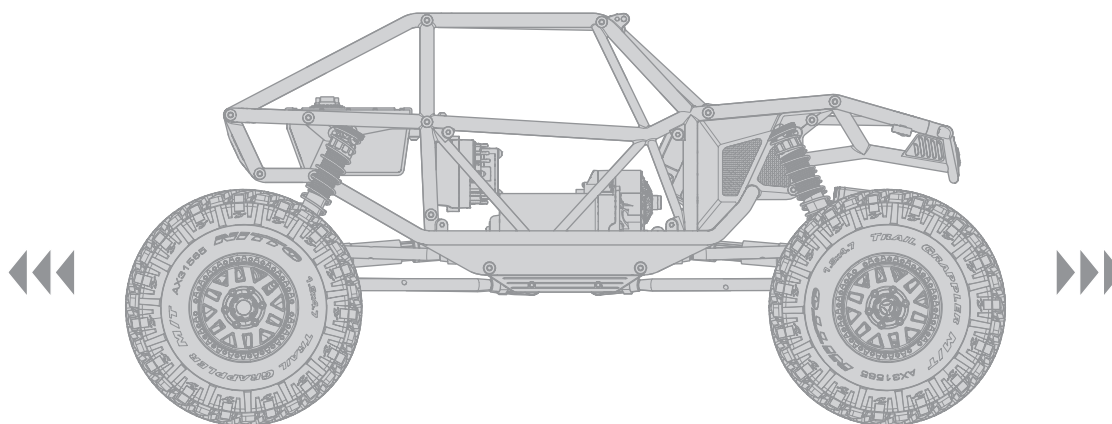

Replace any noticeable bent or broken parts

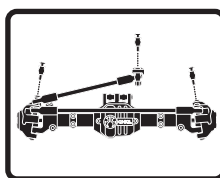

Check for wear on the ball joints in the steering and suspension links (replace if necessary)

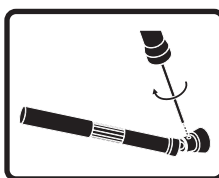

Check driveshaft set screws and apply thread locking compound if necessary

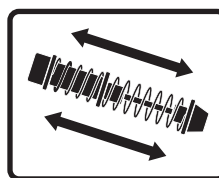

Inspect shock absorbers for smooth dampened operation

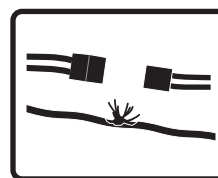

Check for any loose connections or frayed wiring

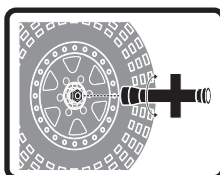

Check the wheel nuts for tightness

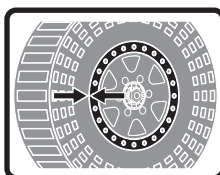

Ensure the wheel beads are still firmly bonded around the entire circumference of the rim

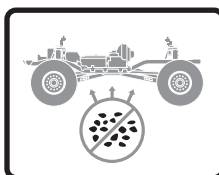

Keep the chassis free of dirt and debris

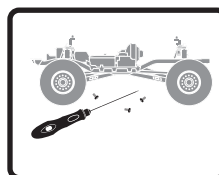

Check for loose screws on the chassis, especially the knuckle, C-hub and axle lockout screws

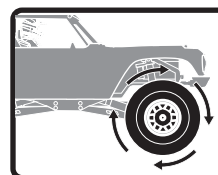

Check the driveline for smooth, bind free operation

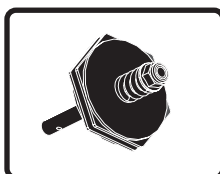

If applicable, check the slipper clutch for proper operation

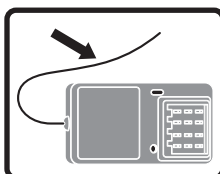

Check the receiver antenna for damage

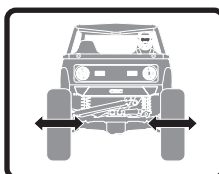

Check the steering operation for any binding

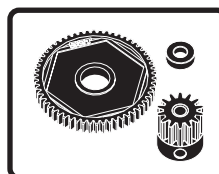

Inspect the spur and pinion gears for damage

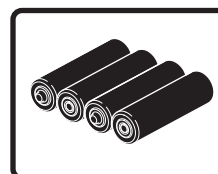

Replace the transmitter batteries when indicated by the transmitter, as described in the Transmitter Functions section

AE-5L FORWARD/REVERSE ESC WITH DRAG BRAKE

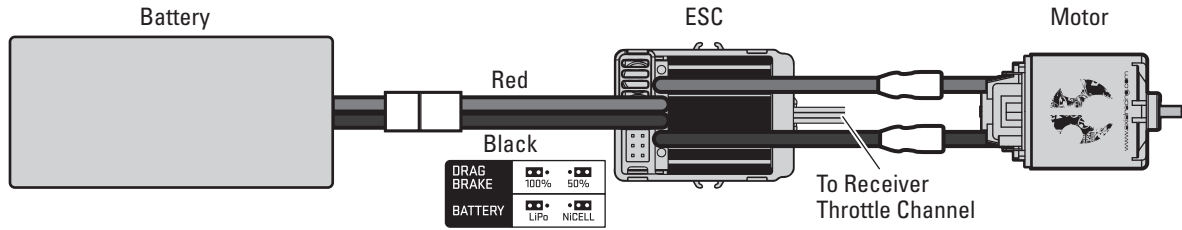

SETUP

Throttle calibration should not be needed out of the box. However, in order to make the throttle range of different transmitters, the calibration of the ESC is necessary:

- Mount the ESC in an area that is well ventilated and isolated from vibration and shock.
- Connect the ESC motor wires to the motor red-to-red and black-to-black.
- Plug the receiver into the throttle channel of the receiver.
- Before plugging the battery into the ESC, make sure your transmitter is on and the throttle trim is set to zero.
- Connect the battery to the ESC. The vehicle will be powered on when the battery is connected.

CAUTION: Keep all body parts and loose clothing away from any moving parts while the battery is connected to the ESC.

CAUTION: Always connect the ESC only to a proper power source that has the correct voltage and polarity. Incorrect voltages or reversed polarity will damage the ESC. Damage to the ESC caused by improper voltage or polarity is not covered under warranty.

- Test forward and reverse control using the transmitter.

To calibrate the ESC:

- Power the transmitter on and set the throttle control to neutral.
- Connect the battery to the ESC and wait 3 seconds to let the ESC initiate a self-test and automatic throttle calibration.
- The ESC is ready to run when a long beep sound is emitted from the motor.
- Always disconnect the battery when the vehicle is not in use.

NOTES

- The drag brake is set to 100% from the factory.
- The LiPo cut-off is set to "ON" from the factory.

ESC SPECIFICATIONS

Input Voltage	2-3S LiPo, 5-9 Cells NiMH/NiCd
Size	46.5mm x 34mm x 28.5mm
Weight	70g
Motor Limit	12T 2S/18T 3S
On-Resistance FET	.002
Rated/Peak Current	180A
Braking Current	90A
BEC Voltage/A	6.0V 3.0A Peak
PWM Frequency	1KHz

ESC SOUND STATUS

1 Short Beep	Battery is NiMH/NiCd
2 Short Beeps	Battery is 2S LiPo
3 Short Beeps	Battery is 3S LiPo
1 Long Beep	Self-test and throttle calibration is OK and ESC is ready to run

TROUBLESHOOTING

PROBLEM	POSSIBLE CAUSE	SOLUTION
Vehicle does not move	Batteries are not installed properly in the transmitter	Ensure the transmitter batteries are properly installed
	Weak or no battery in the vehicle	Install a freshly charged vehicle battery
	Damaged motor	Replace the motor
	Frayed or broken wiring	Replace any damaged wiring
	ESC is shut down by heat protection circuit	Allow the ESC to cool down completely
Loss of vehicle control	Improper antenna placement	Ensure the transmitter antenna is not blocked and the receiver antenna is located properly
	Weak or no batteries in the transmitter or vehicle	Install a freshly charged vehicle battery and new transmitter batteries
	Neutral or trim position is incorrect	Adjust the steering trim
	Receiver and/or battery not connected properly	Check all receiver and battery connections
Steering and/or throttle function is reversed	Servo travel is reversed at the transmitter	Set the transmitter servo reversing switch to the correct position
	Motor wires are not connected properly	Check all motor wires for correct polarity and secure connection

NOTES

LIMITED WARRANTY

What this Warranty Covers

Horizon Hobby, LLC, (Horizon) warrants to the original purchaser that the product purchased (the "Product") will be free from defects in materials and workmanship for a period of 2 years from the date of purchase.

What is Not Covered

This warranty is not transferable and does not cover (i) cosmetic damage, (ii) damage due to acts of God, accident, misuse, abuse, negligence, commercial use, or due to improper use, installation, operation or maintenance, (iii) modification of or to any part of the Product, (iv) attempted service by anyone other than a Horizon Hobby authorized service center, (v) Product not purchased from an authorized Horizon dealer, or (vi) Product not compliant with applicable technical regulations or (vii) use that violates any applicable laws, rules, or regulations.

OTHER THAN THE EXPRESS WARRANTY ABOVE, HORIZON MAKES NO OTHER WARRANTY OR REPRESENTATION, AND HEREBY DISCLAIMS ANY AND ALL IMPLIED WARRANTIES, INCLUDING, WITHOUT LIMITATION, THE IMPLIED WARRANTIES OF NON-INFRINGEMENT, MERCHANTABILITY AND FITNESS FOR A PARTICULAR PURPOSE. THE PURCHASER ACKNOWLEDGES THAT THEY ALONE HAVE DETERMINED THAT THE PRODUCT WILL SUITABLY MEET THE REQUIREMENTS OF THE PURCHASER'S INTENDED USE.

Purchaser's Remedy

Horizon's sole obligation and purchaser's sole and exclusive remedy shall be that Horizon will, at its option, either (i) service, or (ii) replace, any Product determined by Horizon to be defective. Horizon reserves the right to inspect any and all Product(s) involved in a warranty claim. Service or replacement decisions are at the sole discretion of Horizon. Proof of purchase is required for all warranty claims. SERVICE OR REPLACEMENT AS PROVIDED UNDER THIS WARRANTY IS THE PURCHASER'S SOLE AND EXCLUSIVE REMEDY.

Limitation of Liability

HORIZON SHALL NOT BE LIABLE FOR SPECIAL, INDIRECT, INCIDENTAL OR CONSEQUENTIAL DAMAGES, LOSS OF PROFITS OR PRODUCTION OR COMMERCIAL LOSS IN ANY WAY, REGARDLESS OF WHETHER SUCH CLAIM IS BASED IN CONTRACT, WARRANTY, TORT, NEGLIGENCE, STRICT LIABILITY OR ANY OTHER THEORY OF LIABILITY, EVEN IF HORIZON HAS BEEN ADVISED OF THE POSSIBILITY OF SUCH DAMAGES. Further, in no event shall the liability of Horizon exceed the individual price of the Product on which liability is asserted. As Horizon has no control over use, setup, final assembly, modification or misuse, no liability shall be assumed nor accepted for any resulting damage or injury. By the act of use, setup or assembly, the user accepts all resulting liability. If you as the purchaser or user are not prepared to accept the liability associated with the use of the Product, purchaser is advised to return the Product immediately in new and unused condition to the place of purchase.

Law

These terms are governed by Illinois law (without regard to conflict of law principals). This warranty gives you specific legal rights, and you may also have other rights which vary from state to state. Horizon reserves the right to change or modify this warranty at any time without notice.

WARRANTY SERVICES

Questions, Assistance, and Services

Your local hobby store and/or place of purchase cannot provide warranty support or service. Once assembly, setup or use of the Product has been started, you must contact your local distributor or Horizon directly. This will enable Horizon to better answer your questions and service you in the event that you may need any assistance. For questions or assistance,

please visit our website at www.horizonhobby.com, submit a Product Support Inquiry, or call the toll free telephone number referenced in the Warranty and Service Contact Information section to speak with a Product Support representative.

Inspection or Services

If this Product needs to be inspected or serviced and is compliant in the country you live and use the Product in, please use the Horizon Online Service Request submission process found on our website or call Horizon to obtain a Return Merchandise Authorization (RMA) number. Pack the Product securely using a shipping carton. Please note that original boxes may be included, but are not designed to withstand the rigors of shipping without additional protection. Ship via a carrier that provides tracking and insurance for lost or damaged parcels, as Horizon is not responsible for merchandise until it arrives and is accepted at our facility. An Online Service Request is available at http://www.horizonhobby.com/content/service-center_render-service-center. If you do not have internet access, please contact Horizon Product Support to obtain a RMA number along with instructions for submitting your product for service. When calling Horizon, you will be asked to provide your complete name, street address, email address and phone number where you can be reached during business hours. When sending product into Horizon, please include your RMA number, a list of the included items, and a brief summary of the problem. A copy of your original sales receipt must be included for warranty consideration. Be sure your name, address, and RMA number are clearly written on the outside of the shipping carton.

NOTICE: Do not ship Li-Po batteries to Horizon. If you have any issue with a Li-Po battery, please contact the appropriate Horizon Product Support office.

Warranty Requirements

For Warranty consideration, you must include your original sales receipt verifying the proof-of-purchase date. Provided warranty conditions have been met, your Product will be serviced or replaced free of charge. Service or replacement decisions are at the sole discretion of Horizon.

Non-Warranty Service

Should your service not be covered by warranty, service will be completed and payment will be required without notification or estimate of the expense unless the expense exceeds 50% of the retail purchase cost. By submitting the item for service you are agreeing to payment of the service without notification. Service estimates are available upon request. You must include this request with your item submitted for service. Non-warranty service estimates will be billed a minimum of 1/2 hour of labor. In addition you will be billed for return freight. Horizon accepts money orders and cashier's checks, as well as Visa, MasterCard, American Express, and Discover cards. By submitting any item to Horizon for service, you are agreeing to Horizon's Terms and Conditions found on our website http://www.horizonhobby.com/content/service-center_render-service-center.

ATTENTION: Horizon service is limited to Product compliant in the country of use and ownership. If received, a non-compliant Product will not be serviced. Further, the sender will be responsible for arranging return shipment of the un-serviced Product, through a carrier of the sender's choice and at the sender's expense. Horizon will hold non-compliant Product for a period of 60 days from notification, after which it will be discarded.

10/15

WARRANTY AND SERVICE CONTACT INFORMATION

Country of Purchase	Horizon Hobby	Contact Information	Address
United States of America	Horizon Service Center (Repairs and Repair Requests)	servicecenter.horizonhobby.com/RequestForm/	2904 Research Rd Champaign, IL 61822
	Horizon Product Support (Product Technical Assistance)	productsupport@horizonhobby.com 877-504-0233	
	Sales	websales@horizonhobby.com 800-338-4639	
European Union	Horizon Technischer Service	service@horizonhobby.eu	Hanskampring 9 D 22885 Barsbüttel, Germany
	Sales: Horizon Hobby GmbH	+49 (0) 4121 2655 100	

FCC INFORMATION

FCC ID: BRWSTX3

This device complies with part 15 of the FCC rules. Operation is subject to the following two conditions: (1) This device may not cause harmful interference, and (2) this device must accept any interference received, including interference that may cause undesired operation.

 **CAUTION:** Changes or modifications not expressly approved by the party responsible for compliance could void the user's authority to operate the equipment.

This product contains a radio transmitter with wireless technology which has been tested and found to be compliant with the applicable regulations governing a radio transmitter in the 2.400GHz to 2.4835GHz frequency range.

SUPPLIER'S DECLARATION OF CONFORMITY

Axial Capra 1.9 (AXI03000)

 This device complies with part 15 of the FCC Rules. Operation is subject to the following two conditions: (1) This device may not cause harmful interference, and (2) this device must accept any interference received, including interference that may cause undesired operation.

 **CAUTION:** changes or modifications not expressly approved by the party responsible for compliance could void the user's authority to operate the equipment.

NOTE: This equipment has been tested and found to comply with the limits for a Class B digital device, pursuant to part 15 of the FCC Rules. These limits are designed to provide reasonable protection against harmful interference in a residential installation. This equipment generates, uses and can radiate radio frequency energy and, if not installed and used in accordance with the instructions, may cause harmful interference to radio communications. However, there is no guarantee that interference will not occur in a particular installation. If this equipment does cause harmful interference to radio or television reception, which can be determined by turning the equipment off and on, the user is encouraged to try to correct the interference by one or more of the following measures:

- Reorient or relocate the receiving antenna.
- Increase the separation between the equipment and receiver.
- Connect the equipment into an outlet on a circuit different from that to which the receiver is connected.
- Consult the dealer or an experienced radio/TV technician for help.

Horizon Hobby, LLC
2904 Research Rd.,
Champaign, IL 61822
Email: compliance@horizonhobby.com
Web: HorizonHobby.com

IC INFORMATION

CAN ICES-3 (B)/NMB-3(B)

IC: 6157A-STX3

This device complies with Industry Canada licence-exempt RSS standard(s). Operation is subject to the following two conditions:

(1) this device may not cause interference, and (2) this device must accept any interference, including interference that may cause undesired operation of the device.

COMPLIANCE INFORMATION FOR THE EUROPEAN UNION

EU COMPLIANCE STATEMENT:

Axial Capra 1.9 (AXI03000)

Horizon Hobby, LLC hereby declares that this product is in compliance with the essential requirements and other relevant provisions of the RED and EMC Directives.

A copy of the EU Declaration of Conformity is available online at: <http://www.horizonhobby.com/content/support-render-compliance>.

INSTRUCTIONS FOR DISPOSAL OF WEEE BY USERS IN THE EUROPEAN UNION



This product must not be disposed of with other waste. Instead, it is the user's responsibility to dispose of their waste equipment by handing it over to a designated collection point for the recycling of waste electrical and electronic equipment. The separate collection and recycling of your waste equipment at the time of disposal will help to conserve natural resources and ensure that it is recycled in a manner that protects human health and the environment. For more information about where you can drop off your waste equipment for recycling, please contact your local city office, your household waste disposal service or where you purchased the product.



E328

**WHEELS AND TIRES
REIFEN UND RÄDER
ROUES ET PNEUS
RUOTE E PNEUMATICI**

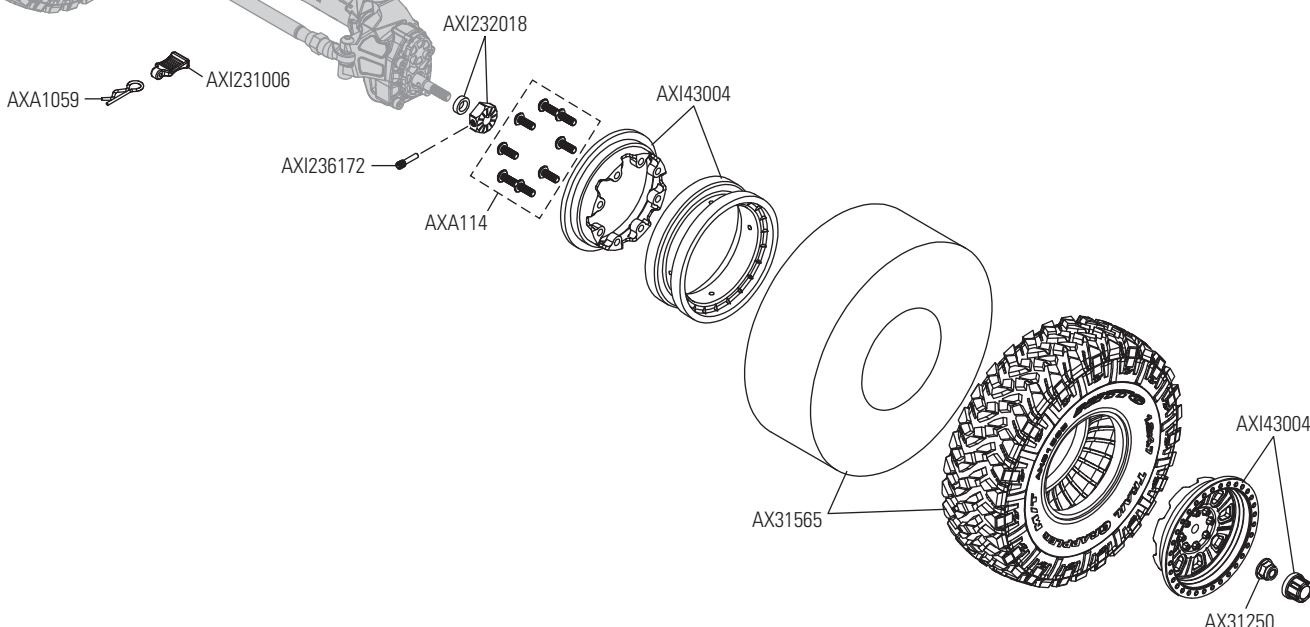
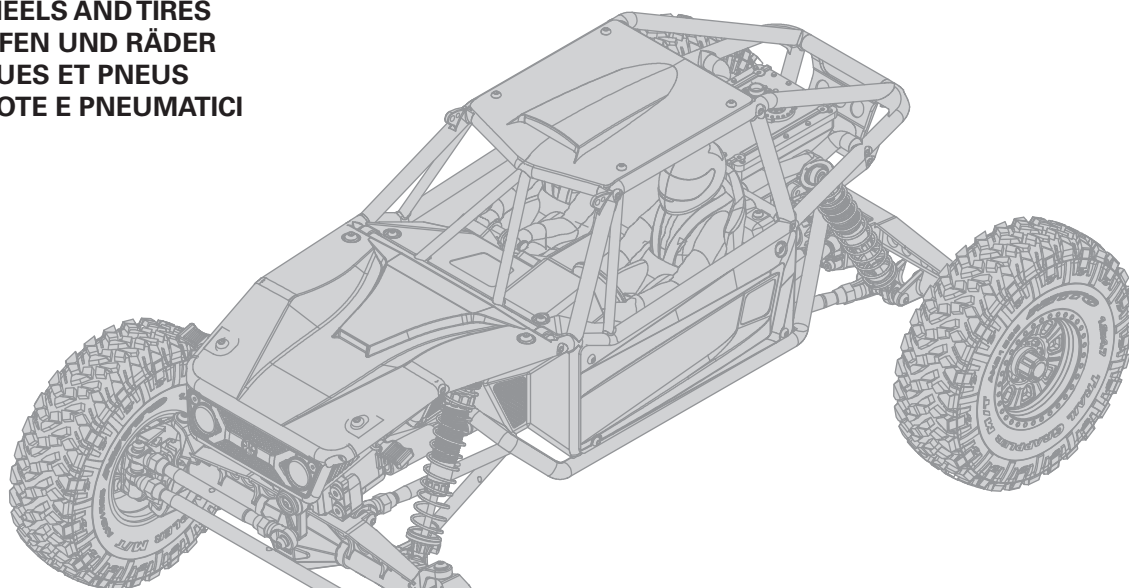

**SHOCK ABSORBERS
STOSSDÄMPFER
AMORTISSEURS
AMMORTIZZATORI**

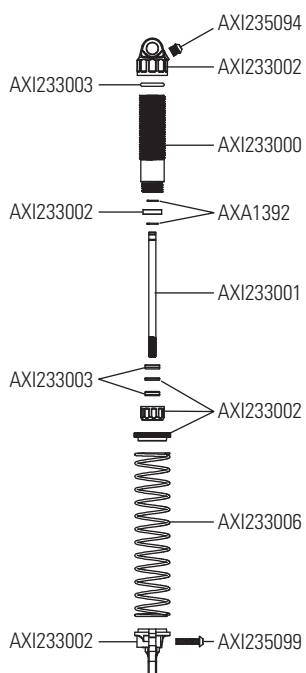

PARTS LISTS // TEILELISTEN // LISTE DES PIÈCES // ELENCO COMPONENTI

Part #	Description	Beschreibung	Description	Descrizione
AXI230010	Head Light Lens	Scheinwerferlinse	Lentilles de phares	Lenti per faro
AXI230011	Interior Set	Interieurset	Ensemble d'intérieur	Set interni
AXI230012	Body Panel Set (Clear)	Karosserieteilesatz, farblos	Ensemble de panneaux de carrosserie, transparent	Set pannelli carrozzeria, trasparente
AXI231005	Skid Plate	Motorschutz	Plaque de protection	Piastra di protezione
AXI231006	UTB Cage Set Complete	Überrollkäfigset, komplett	Ensemble de cages complet	Set scocca completo
AXI232002	6-Bolt Differential Locker	6-Schrauben-Differenzial-Sicherung	Blocage différentiel à 6 boulons	Blocco differenziale 6 bulloni
AXI232003	6 Bolt Heavy Duty Gear Set	6-Schrauben-Schwerlast-Zahnradatz	Ensemble d'engrenages haute résistance à 6 boulons	Set ingranaggio impieghi gravosi 6 bulloni
AXI232004	F9 Portal Axl housing FR	Currie F9-Portalachsgehäuse, vorne	Carter d'essieu du portique Currie F9, avant	Currie F9 Portal, alloggiamento assale, anteriore
AXI232005	F9 Portal Axl housing RR	Currie F9-Portalachsgehäuse, hinten	Carter d'essieu du portique Currie F9, arrière	Currie F9 Portal, alloggiamento assale, posteriore
AXI232006	F9 Portal Str knucl & Cap	Currie F9 Portal-Achsschenkel und -abdeckung	Rotule de direction et coiffe du portique Currie F9, arrière	Currie F9 Portal, fuso a snodo e tappo
AXI232007	32P Portal Gr Set 23T/12T 2pc	32P Portalachssatz 23T/12T (2)	Ensemble engrenage portique 32P 23T/12T (2)	Set ingranaggi 32P Portal 23T/12T (2)
AXI232008	Portal Stub Axle (2)	Portalachsschenkel (2)	Demi-essieu du portique (2)	Fusello Portal (2)
AXI232009	F9 Universal Axle Set (2pc)	Currie F9-Universalachsset (2)	Ensemble d'essieux universels Currie F9 (2)	Currie F9, set assale universale (2)
AXI232010	F9 Straight Axle Shaft 2pc	Currie F9, Gerade Achswelle (2)	Ensemble d'essieux droits Currie F9 (2)	Currie F9, set assale dritto (2)
AXI232011	Dig Transmission Case Set	Grabgetriebe-Abdeckungssatz	Ensemble boîtier de transmission dig	Set scatola cambio dig
AXI232012	Dig Trans Metal Gear Set	Grabgetriebe-Metalgetriebesatz	Ensemble d'engrenages métalliques de transmission dig	Set ingranaggi trasmissione dig in metallo
AXI232013	Dig Transmission Shaft Set	Grabtriebewellensatz	Ensemble d'arbres de transmission dig	Set albero trasmissione dig
AXI232014	Dig Trans Dig Cmpnts	Grabgetriebe, „Grab“-komponenten	Composants « dig » transmission dig	Componenti trasmissione dig
AXI232015	Dig Trans Slipper Pads/Plts	Grabgetriebe-Gleitschuhe/-platten	Sabots de pistons/plaques de sabot de transmission dig	Piastre/pattini di scorrimento trasmissione dig
AXI232016	Dig Trans Mnts&Srvo Svr Set	Grabgetriebe-Halterungen und Servo-Saversatz	Ensemble supports et économiseur de servo de transmission dig	Set salvaservo e supporti trasmissione dig
AXI232017	Wild Boar Driveshaft Set	Wild Boar-Antriebswellensatz	Ensemble d'arbres de transmission Wild Boar	Set albero di trasmissione Wild Boar
AXI232018	12mm Hex Pin and Spacer (4)	12-mm-Sechskantstift und Abstandhalter (4)	Broche hexagonale 12mm et entretoise (4)	Distanziale e perno esagonale 12mm (4)
AXI233000	Thrd AL Shk Bdy 11x41.5mm HA 2pc	Gewinde-Aluminium-Stoßdämpfergehäuse 11x41,5mm HA (2)	Carrosserie d'amortisseurs en aluminium fileté 11x41,5mm HA (2)	Scocca ammortizzatore filettata in alluminio 11x41,5mm HA (2)
AXI233001	Shock Shaft M3x53.4 (2pcs)	Kolbenstange M3 x 53,4 mm (2)	Bras d'amortisseur M3x53,4mm (2)	Albero ammortizzatore M3x53,4mm (2)
AXI233002	Shock Prts Molded	Stoßdämpferteile, gegossen	Pièces de l'amortisseur moulées	Parti ammortizzatore stampate
AXI233003	Shock O-Ring Set	O-Ring-Satz für den Stoßdämpfer	Ensemble de joints toriques d'amortisseur	Set O-Ring ammortizzatore
AXI233004	Spring 13x70mm .72lbs/in Prpl(2)	Feder 13x70mm 0,72 lbs/in (326 g/Zoll), violett (2)	Ressort 13x70mm 0,72lbs/po, violet (2)	Molla 13x70mm 0,72lbs/in (326 g/pollice), viola (2)
AXI233006	Spring 13x70mm 1.72lbs/in Red(2)	Feder 13x70mm 1,72 lbs/in (780 g/Zoll), rot (2)	Ressort 13x70mm 1,72lbs/po, rouge (2)	Molla 13x70mm 1,72lbs/in (780 g/pollice), rosso (2)
AXI233008	Spring 13x70mm 2.4lbs/in Grn(2)	Feder 13x70mm 2,4 lbs/in (1,08 kg/Zoll), grün (2)	Ressort 13x70mm 2,4lbs/po, vert (2)	Molla 13x70mm 2,4lbs/in (1,08 kg/pollice), verde (2)
AXI234003	Pvt Ball,Stainless12.75mm(4)	Kugelzapfen, Edelstahl 12,75 mm (4)	Rotule, acier inoxydable 12,75mm (4)	Pivot ball, inossidabile, 12,75mm (4)
AXI234004	Susp Pvt Ball, Stainless 7.5mm	Kugelzapfen für Federung, Edelstahl 7,5 mm	Rotule de suspension, acier inoxydable 7,5mm	Pivot ball sospensioni, indossabile, 7,5mm
AXI234005	Steering Lnks Stainless Stl	Spurstangen, Edelstahl	Tringleries de direction, acier inoxydable	Tiranti sterzo, inossidabili
AXI234006	HD Rod Ends M4 20pcs	Schwerlast-Stangenköpfe M4 (20)	Embouts de bielle haute résistance M4 (20)	Teste a snodo per impiego gravoso M4 (20)
AXI234007	SS M6x 111mm Link (2pcs)	Edelstahlglied M6 x 111 mm (2)	Liaison en acier inoxydable M6x111mm (2)	Braccetti in acciaio inossidabile M6x111mm (2)
AXI234008	SS M6x 111mm Link (2pcs)	Edelstahlglied M6x111mm (2)	Liaison en acier inoxydable M6x111mm (2)	Braccetti in acciaio inossidabile M6x111mm (2)
AXI234009	Stainless Steel M6 x 89mm Link	Edelstahlglied M6x89mm (2)	Liaison en acier inoxydable M6x89mm (2)	Braccetti in acciaio inossidabile M6x89mm (2)
AXI235014	M2.5 x 10mm, Cap Head Screw (10)	Inbusschraube, M2,5x10mm (10)	Vis d'assemblage creuse, M2,5x10mm (10)	Vite a testa cilindrica M2,5x10mm (10)
AXI235016	M2.5 x 16mm, Cap Head Screw (10)	Inbusschraube, M2,5x16mm (10)	Vis d'assemblage creuse, M2,5x16mm (10)	Vite a testa cilindrica M2,5x16mm (10)
AXI235094	M2.5 x 3mm, Button Head (10)	Rundkopfschraube, M2,5x3mm (10)	Vis à tête bombée, M2,5x3mm (10)	Vite a testa tonda M2,5x3mm (10)
AXI235097	M2.5 x 6mm, BHS (10)	Rundkopfschraube, M2,5x6mm (10)	Vis à tête bombée, M2,5x6mm (10)	Vite a testa tonda M2,5x6mm (10)
AXI235098	M2.5 x 8mm Button Head Screw(10)	Rundkopfschraube, M2,5x8mm (10)	Vis à tête bombée, M2,5x8mm (10)	Vite a testa tonda M2,5x8mm (10)
AXI235099	M2.5 x 10mm, Button Head (10)	Rundkopfschraube, M2,5x10mm (10)	Vis à tête bombée, M2,5x10mm (10)	Vite a testa tonda M2,5x10mm (10)
AXI235102	M2.5 x 18mm, BHS (10)	Rundkopfschraube, M2,5x18mm (10)	Vis à tête bombée, M2,5x18mm (10)	Vite a testa tonda M2,5x18mm (10)
AXI235109	M3 x 14mm, Button Head Screw(10)	Rundkopfschraube, M3x14mm (10)	Vis à tête bombée, M3x14mm (10)	Vite a testa tonda M3x14mm (10)
AXI235169	M2.5 x 12mm, Flat Head Screw(10)	Flachkopfschraube, M2,5x12mm (10)	Vis à tête plate, M2,5x12mm (10)	Vite a testa piana M2,5x12mm (10)
AXI235330	M3x30mm,Cup Point Set Screw (10)	Stellschraube mit Ringschneide M3x30mm (10)	Vis de fixation à bout cuvette M3x30mm (10)	Vite di fermo senza testa M3x30mm (10)
AXI236171	M2.5 x 10mm Pin (6)	Stift M2,5x10mm (6)	Axe M2.5x10 mm (6)	Perno M2,5x10mm (6)
AXI236172	Screw Shaft M3x2.0x12mm	Schraubenschaft M3x2x12mm	Tige de vis M3x2x12 mm	Albero filettato M3x2x12mm
AXI43004	3pc Raceline Mnstr bdlk whl (2)	3x Raceline Monster Beadlock-Rad (2)	3 pièces de verrou de talon Raceline Monster (2)	Cerchio Beadlock Raceline Monster in 3 pezzi (2)
AXIC0012	AXA120 Hex Socket Btn Hd M3x25mm	Sechskant-Rundkopfschraube M3x25mm	Douille à six pans à tête bombée M3x25mm	Vite a testa tonda con esagono incassato M3x25mm

Part #	Description	Beschreibung	Description	Descrizione
AXIC0013	AXA013 Cap Hd M2x6mm Blk Oxide	Inbusschraube, M2x6mm, Schwarzoxid	Vis d'assemblage creuse M2x6mm brunie	Vite a testa cilindrica M2x6mm ossido nero
AXIC0115	AXA115 Hex Skt Butn Head M3x10mm	Sechskant-Rundkopfschraube, M3x10mm	Douille à six pans à tête bombée M3x10mm	Vite a testa tonda con esagono incassato M3x10mm
AXIC0118	AXA144 Hex Flt Hd M3x8mm Blk10mm	Sechskant-Flachkopfschraube, M3x8mm, schwarz (10)	Douille à six pans à tête plate M3x8mm noire (10)	Vite a testa piana esagonale M3x8mm nero (10)
AXIC0146	AXA146 Hex Skt Flat Hd M3x12mm	Sechskant-Flachkopfschraube, M3x12mm	Douille à six pans à tête plate M3x12mm	Vite a testa piana con esagono incassato M3x12mm
AXIC0218	AXA1218 Bearing 5x10x4mm	Lager 5x10x4mm	Roulement 5x10x4mm	Cuscinetto 5x10x4mm
AXIC0221	AXA1221 Bearing 5x11x4mm	Lager 5x11x4mm	Roulement 5x11x4mm	Cuscinetto 5x11x4mm
AXIC0286	AXA0286 Screw Shaft M4x2.5x12mm	Schraubenschaft M4x2,5x12 mm	Tige de vis M4x2,5x12mm	Albero filettato M4x2.5x12mm
AXIC0291	AXA291 Set Scr M4x4mm Blk Ox(6)	Stellschraube, M4x4mm, Schwarzoxid (6)	Vis de fixation M4x4mm brunie (6)	Vite di fermo M4x4 mm ossido nero (6)
AXIC0795	AX31586 Wb8-hd Std Driveshafts	WB8-HD Standard-Antriebswelle	Arbre de transmission standard WB8-HD	Albero di trasmissione standard WB8-HD
AXIC1009	AXA0109 Hex Skt Oversize M3x10mm	Sechskant-Übergröße M3x10mm	Douille à 6 pans surdimensionnée M3x10mm	Viti oversize con esagono incassato M3x10mm
AXIC1148	AX31148 Wb8-hd Drvshft Coupler	WB8-HD-Antriebswellenkupplung	Ensemble de couplage d'arbre de transmission WB8-HD	Accoppiamento albero trasmissione WB8-HD
AXIC1180	AXA118 Hex Socket BtnHd M3x18mm(10)	Sechskant-Rundkopfschraube M3x18mm (10)	Douille à six pans à tête bombée M3x18mm (10)	Viti a testa tonda con esagono incassato M3x18mm (10)
AXIC1243	AXA1243 Bearing 15x21x4mm (2)	Lager 15x21x4mm (2)	Roulement à billes 15x21x4mm (2)	Cuscinetto 15x21x4mm (2)
AXIC3066	AX31066 Cap Hd M2x8mm Blk (10)	Inbusschraube M2x8mm, schwarz (10)	Vis d'assemblage creuse M2x8mm noire (10)	Vite a testa cilindrica M2x8mm nero (10)
AXIC3150	AX31250 Ser Nyl Nut Blk 4mm(10)	Nylon-Feststellflanschmutter, 4mm (10)	Contre-écrou en nylon strié 4mm (10)	Dato flangiato Nylock nero 4mm (10)
AXIC3165	AX30165 Pin 2.5x12mm (6)	Stift 2,5x12mm (6)	Axe M2,5x12mm (6)	Perno 2,5x12mm (6)
AXIC4406	AX31406 Bearing 7x14x3.5mm (2)	Lager 7x14x3,5mm (2)	Roulement 7x14x3,5mm (2)	Cuscinetto 7x14x3,5mm (2)
AXIC4407	AX31407 Bearing 5x14x5mm (2)	Lager 5x14x5mm (2)	Roulement 5x14x5 mm (2)	Cuscinetto 5x14x5mm (2)
AX31565	1.9" Nitto Trail Grappler Monster Truck R35 Compound Tire (2)	1,9 Zoll Nitto Trail Grappler Monster-Truck R35 Compound Reifen (2)	Pneu 1.9" Nitto Trail Grappler Monster Truck R35 Compound (2)	Pneumatico compound 1.9" Nitto Trail Grappler Monster Truck R35 (2)
DYNS2213	WPAE-5L Brshd ESC LED Port w/IC3	WPAE-5L gebürsteter Geschwindigkeitsregler LED-Anschluss mit IC3	Port DEL de variateur ESC à balais WPAE-5L avec IC3	ESC con spazzole WPAE-5L porta LED con IC3
SPMS614	S614 Metal Gear Servo 23T WP	S614 Metallgetriebeservo 23T WP	Servo à engrenages métalliques S614, 23 dents, étanche	Servo con ingranaggi in metallo S614 23T WP
SPMSRX300	SRX300 3CH Receiver	SRX300 3CH Empfänger	Récepteur 3 canaux SRX300	Ricevitore SRX300 3 canali
SPMSSX107	SX107 Micro Metal Gear Servo	SX107 Mikro-Metallgetriebeservo	Micro servo à engrenages métalliques SX107	Micro servo con ingranaggi in metallo SX107
SPMSTX300	Stx 3Ch 2.4 Ghz Fhss Radio Sys	Stx 2,4 Ghz Fhss-Funksys Mit 3 Kan	Système Radio Stx 3 Canaux 2,4 Ghz Fhss	Sistema Radio Fhss Stx 3 Ch 2,4 Ghz

ELECTRONICS // ELETTRONICA // COMPOSANTS ÉLECTRONIQUES // ELETTRONICA

Part #	Description	Beschreibung	Description	Descrizione
AX31312	35T Electric Motor	35T Elektromotor	Moteur électrique 35T	Motore elettrico 35T
SPMSTX300	STX3 3CH Radio	STX3 3CH Sender	Radio 3 canaux STX3	Radiocomando STX3 3 canali
SPMSRX300	SRX300 3CH Receiver	SRX300 3CH Empfänger	Récepteur 3 canaux SRX300	Ricevitore SRX300 3 canali
SPMS614	S614 Metal Gear Servo 23T WP	S614 Metallgetriebeservo 23T WP	Servo à engrenages métalliques S614, 23 dents, étanche	Servo con ingranaggi in metallo S614 23T WP
SPMSSX107	SX107 Micro Metal Gear Servo	SX107 Mikro-Metallgetriebeservo	Micro servo à engrenages métalliques SX107	Micro servo con ingranaggi in metallo SX107
DYNS2213	AE-5L ESC w/LED Ports and Lights (2 White, 4 White, 2 Red)	AE-5L Geschwindigkeitsregler mit LED-Anschlüssen und -Leuchten (2 x weiß, 4 x weiß, 2 x rot)	Variateur ESC AE-5L avec ports et témoins DEL (2 blancs, 4 blancs, 2 rouges)	ESC AE-5L con porte e luci LED (2 bianche, 4 bianche, 2 rosse)

OFFICIALLY LICENSED BY:

AXI03000



EXPLORE

facebook.com/axialinc | instagram.com/axialracing | twitter.com/axialrc
youtube.com/axialvideos | flickr.com/axialrc



©2019 Horizon Hobby, LLC.

Axial, the Axial logo, Capra, DSM, STX3, IC3 and the Horizon Hobby logo are trademarks or registered trademarks of Horizon Hobby, LLC. The Spektrum trademark is used with permission of Bachmann Industries, Inc. Nitto® and Trail Grappler® are registered trademarks of Nitto Tire U.S.A., Inc. The CRC name and logo are trademarks or registered trademarks of Casey Currie Motorsports. The Raceline Wheels name and logo are trademarks or registered trademarks of Allied Wheel Components, Inc. All other trademarks, service marks and logos are property of their respective owners.

Completed 11/19

AXI03000

59181.1