



EstesRockets.com

SATURN V SKYLAB

1973



MODEL ROCKET INSTRUCTIONS

KEEP FOR FUTURE REFERENCE

IMPORTANT: Please record date found on decal and keep for future reference. _____

READ ALL INSTRUCTIONS. Make sure you have all parts and supplies. Test fit all parts before applying glue.

The uncrewed Skylab was launched aboard a modified Saturn V launch vehicle from NASA's Kennedy Space Center. The initial concept for the United States' first space station was devised at NASA's Marshall Space Flight Center. Marshall managed the development of Skylab hardware, provided the Saturn launch vehicles for the four Skylab missions and directed many of the space station's experiments. Over the course of its human

occupation from May 25, 1973, to February 8, 1974, three crews visited Skylab, carried out 270 scientific and technical investigations and logged a combined 171 days on orbit. From – NASA.gov
Enjoy building your Saturn V Skylab and all the dreams it may inspire!

SUPPLIES:

#220, #320, #400 AND #600 SANDPAPER
PENCIL
TWEEZERS
HOBBY KNIFE AND SEVERAL SHARP BLADES
YELLOW GLUE
TUBE-TYPE PLASTIC CEMENT
LIQUID PLASTIC CEMENT
PERMANENT SPRAY ADHESIVE (NOT ARTIST'S OR REPOSITIONABLE)
EPOXY

CA
CA ACCELERATOR
SANDING SEALER (OR SANDABLE AUTO PRIMER)
PUTTY FOR PLASTIC MODELS
PAINTER'S MASKING TAPE
SMALL PAINT BRUSH
FLAT BLACK PAINT
FLAT WHITE PAINT
SILVER PAINT

Do not use lacquer based paints! They can melt the surface of the plastic parts.

Please be extremely careful using cyanoacrylate adhesive (CA). Avoid getting in your eyes or on your skin. Safety glasses are recommended. Use adhesives and paint only in areas with adequate ventilation. Read all instructions.

Before beginning to build with vac-formed plastic parts, read the following carefully.

Cutting Vac-Formed Parts

Cutting vac-formed plastic parts requires patience. Applying light pressure, make repeated passes with the blade to cut through the plastic. Be sure to keep the blade in the same cut line each time; too much pressure will cause the blade to move and not cut cleanly.

Sanding and Trimming Vac-Formed Parts

Once the part is free of excess plastic, sand the edges to remove any flash and to provide a smooth, flat bonding surface. Secure a sheet of #220 or #320 grit sandpaper to a flat surface. (You may want to use wet-or-dry sandpaper with a little water to avoid clogging or loading the sandpaper with plastic dust.) Move each part in a circle against the sandpaper with pressure evenly distributed to avoid uneven sanding. Applying too much pressure can cause uneven edges. When working with thin edges, be careful not to remove too much plastic or generate too much heat that may warp and destroy the part.

NOTE: Double sided tape may be used to hold small parts. Use a file to remove excess plastic on hard to hold small parts.

Adhesives for Vac-Formed Parts

Because vac-formed parts are thinner than injection molded parts, different adhesives should be used. Two basic types give good results and you should have both on hand when building this model.

First is liquid plastic cement. Our preferred brands are Plastic Weld Cement* (Plastruc*), Testor's Plastic Cement #3502*, Tenax 7R*, and Testor's* or Tamiya* glue pens. Liquid cements work on styrene by dissolving the plastic and creating a chemically welded bond. As a result, a little bit goes a long way! Liquid cements are usually applied with an artist's brush. The trick to using plastic cement is to take advantage of the liquid flowing out from the brush by allowing

cement to bleed into close fitting parts and then squeezing the parts together to bond. Work on a small area at one time as plastic cement sets quickly.

The second adhesive to have on hand is a super glue or cyanoacrylate for plastics. We recommend Plasti-Zap*. You'll also want to use CA accelerators for plastics for these, but use a toothpick or a pipette to apply accelerator one drop at a time. When sprayed from their normal applicators, most regular CA accelerators will soften and stain plastic surfaces.

Filling the Seams

This is a necessary step in constructing vac-formed models. Because these models have seams, they need to be filled and smoothed. The putties we recommend are 3M Accyl-Blue* (Usually found at auto body supply shops - one tube will last a long time.) and Squadron* Green or White Putty (usually found in hobby shops.)

When working with putty or filler use as little as possible. Excess putty in a seam creates extra work in sanding it away, as well as the possibility of a "sinkhole" (where the putty collapses the skin of the plastic and eats it away.) Use masking tape along seams to minimize excess putty from adhering to the work area. Use multiple layers when building up low areas, rather than one thick layer of putty. Doing so will reduce shrinkage, cracking, and the risk of sinkholes. Let the putty dry overnight before attempting to sand it away. Wet-or-dry sandpaper, used wet, works best. Start with #220 grit and work your way through #320 to #400. Then polish the area with #600.

The marks ESTES®, the Estes® rocket logo, and Porta-Pad® are marks of Estes Industries, LLC registered in the U.S. and other countries. *All other product names and marks are the property of their respective owners.

PARTS

073213
Nose cone

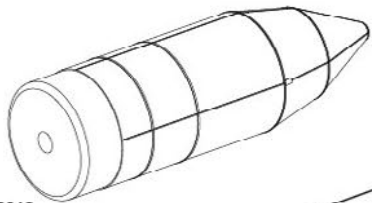

030460
Spacer ring display coupler



030434
Third stage body tube

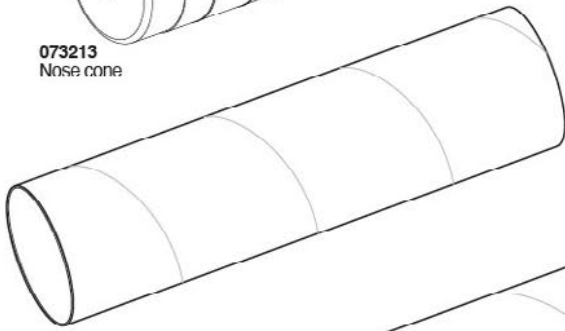

030280
Main body coupler
1 3/8" (3.5 cm)

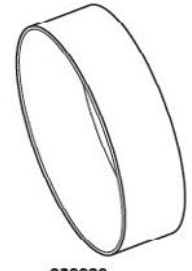

030449
Main body tube

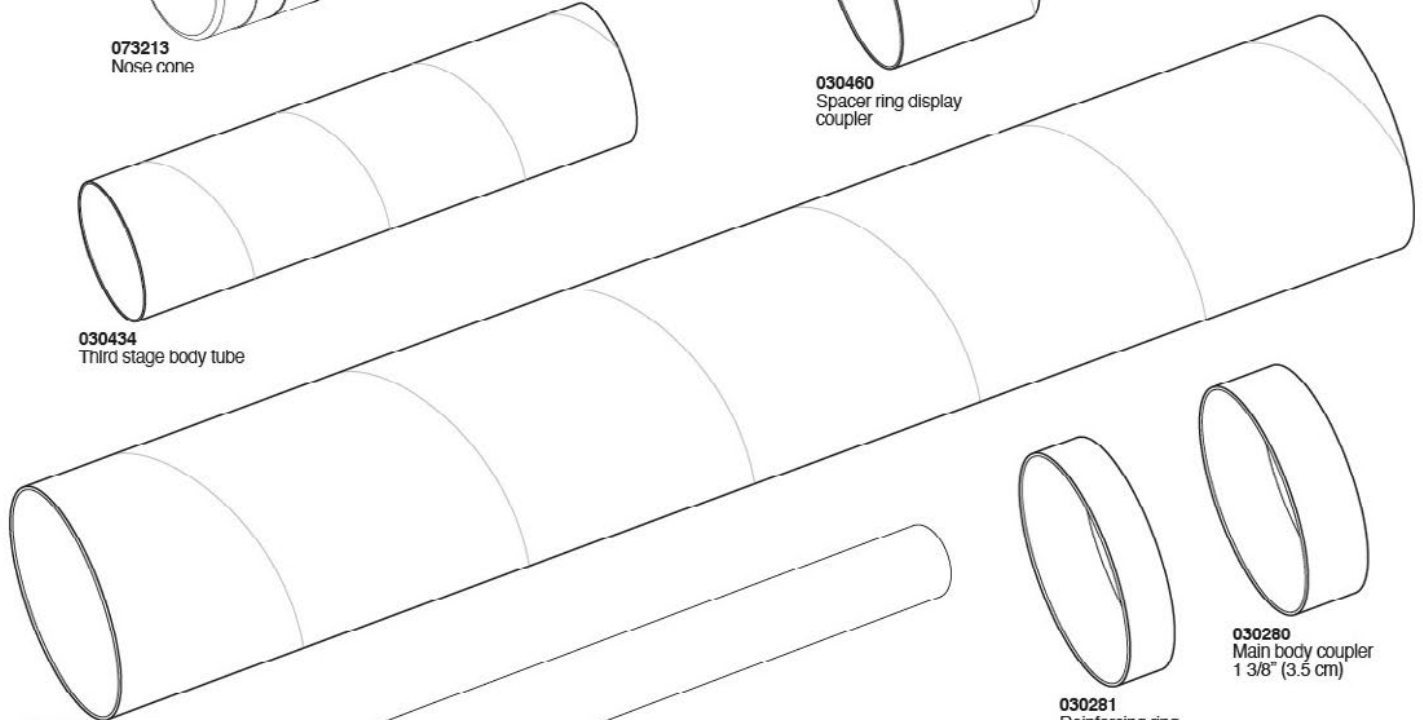

030281
Reinforcing ring
1" (25 mm)

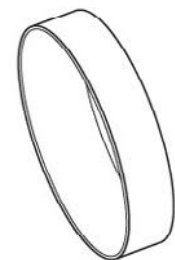

031963
Engine mount tube

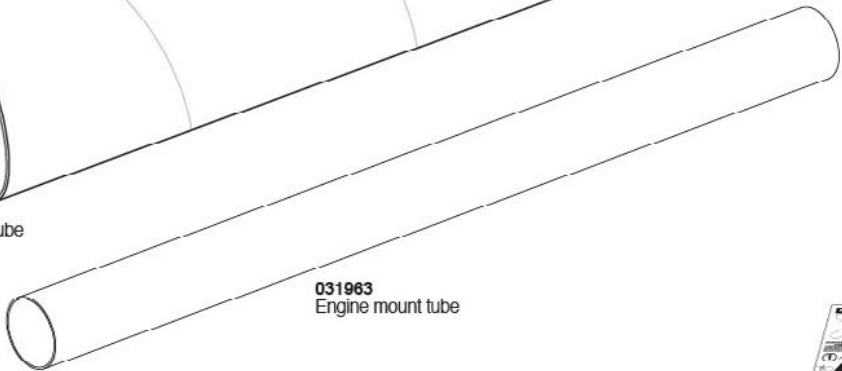

038363
Shock cord



035826
Parachute 24" (61 cm)

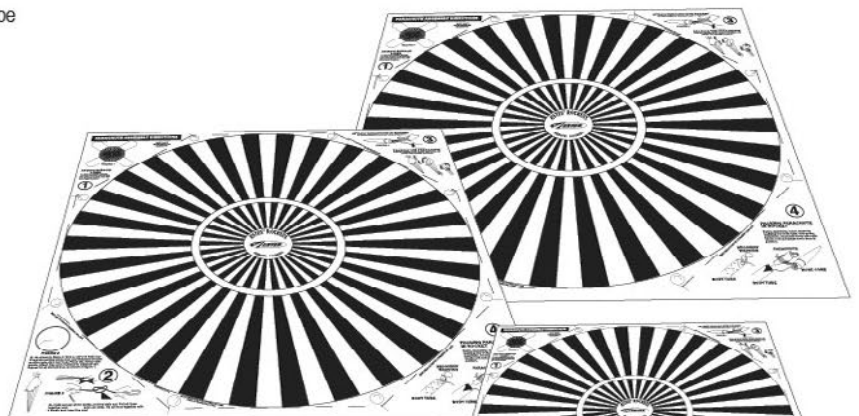

035827
Parachute 18" (46 cm)

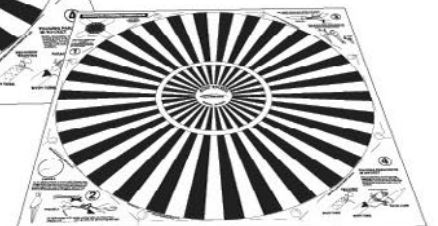

038408
Tape disk strip

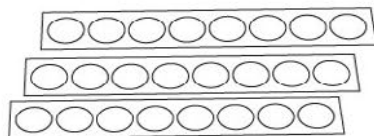

072412
Engine retainer



085705
Clay

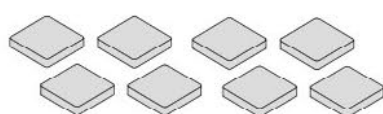

038236
Shroud line (3 bundles)

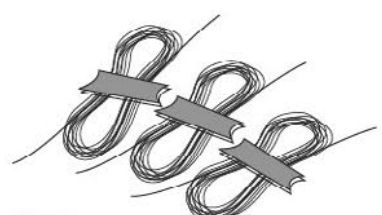

CARD STOCK

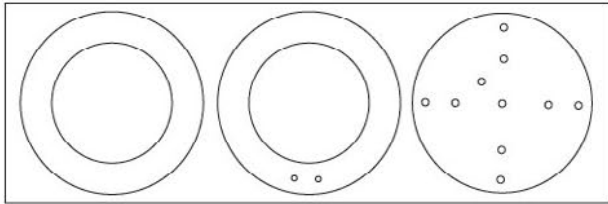

032471
L/C centering rings

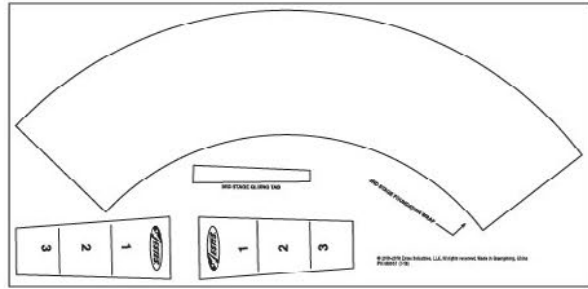

083951
Printed card (shock cord mounts, 3rd stage foundation wrap)

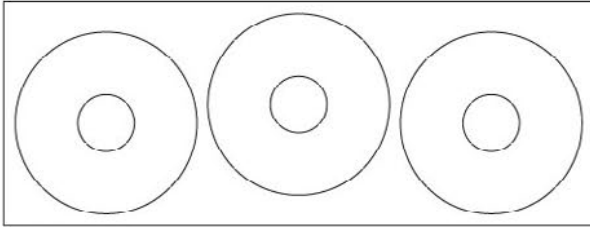

090062B-1973
L/C engine mount centering rings

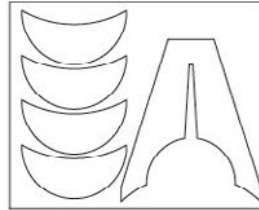

090052A-1973
L/C Fin assembly parts

087091
VACUUM FORMED PARTS

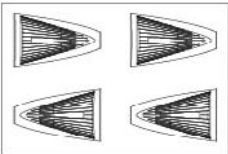

Fairing sheet

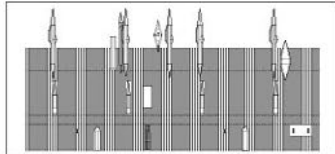

Second stage wrap

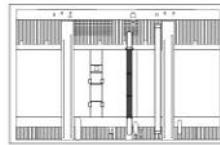

3rd stage wrap



Upper 2nd stage wrap

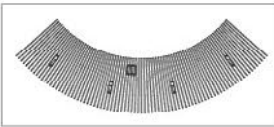

BODY WRAP REDUCTION



Intertank wrap



1st stage wrap

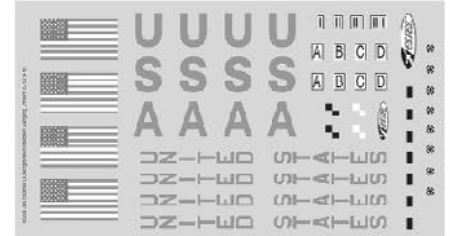

090001-1973
Waterslide decal

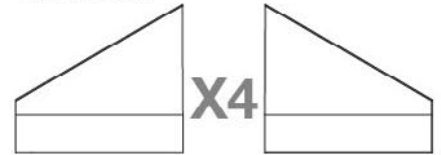

073156
Injected molded fins

PLASTIC PARTS

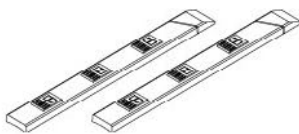

033624
Solar array wings

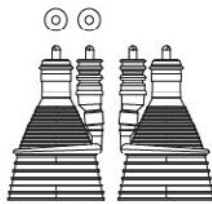

X5

033200
Engine nozzles



038182
Launch lugs



033625
Half round tunnels

MARK TUBES

1. Use a door frame as a guide to draw a straight line down the main and third stage body tubes.

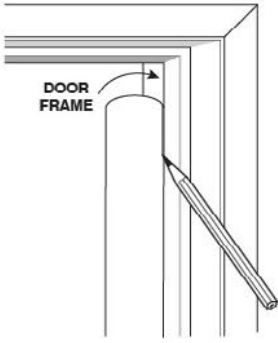

2. Mark the alignment line on the main body tube at $3''$ (7.6 cm), $8\frac{7}{16}''$ (21.4 cm), and at $18\frac{3}{8}''$ (46.7 cm). The end you measure from is now the REAR of the tube.

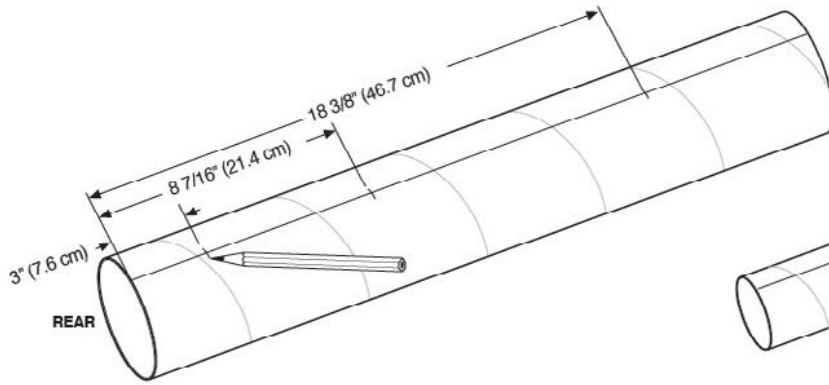

3. Mark alignment line as shown. This is now the FRONT of the tube.

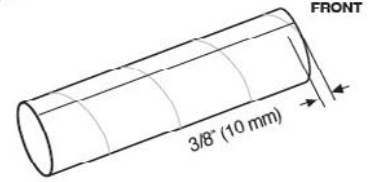

ASSEMBLE ENGINE MOUNT

1.

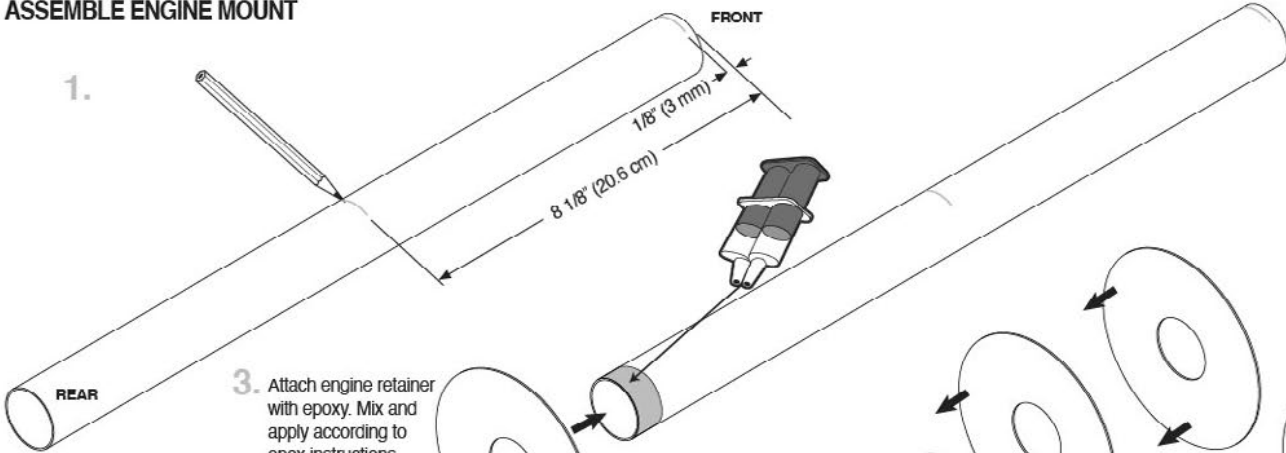

3. Attach engine retainer with epoxy. Mix and apply according to epox instructions. Let dry.

2. Rough up inside surface with sandpaper.

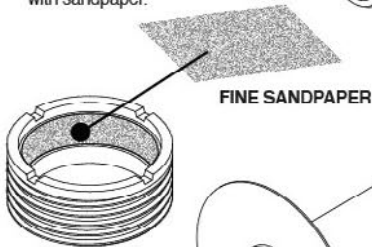

4. Apply glue on marks made in step 1

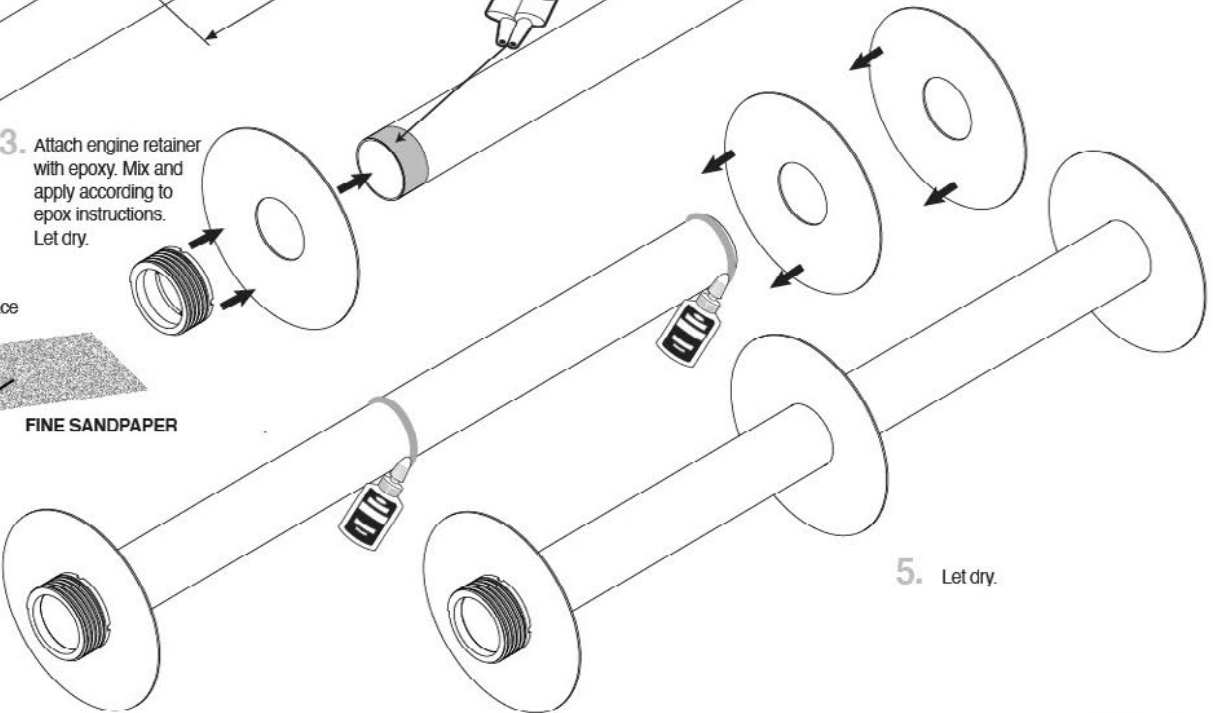

5. Let dry.

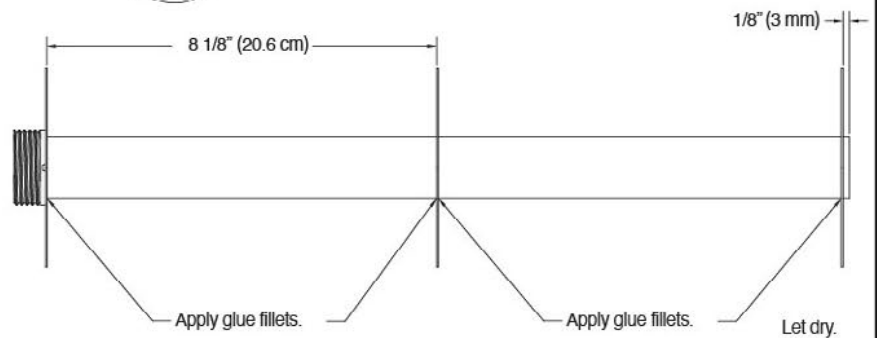

INSTALL ENGINE MOUNT AND CENTERING RINGS

1. Slide the front ring on the engine mount into the rear end of the main body tube, apply a ring of glue just inside the rear of the body tube, then slide the rest of the engine mount in until the rear ring is $3\frac{3}{8}$ " (8.6 cm) from the rear end of the body tube. Apply a bead of glue to the ring/tube joints at each end, let dry, then fillet the joints.

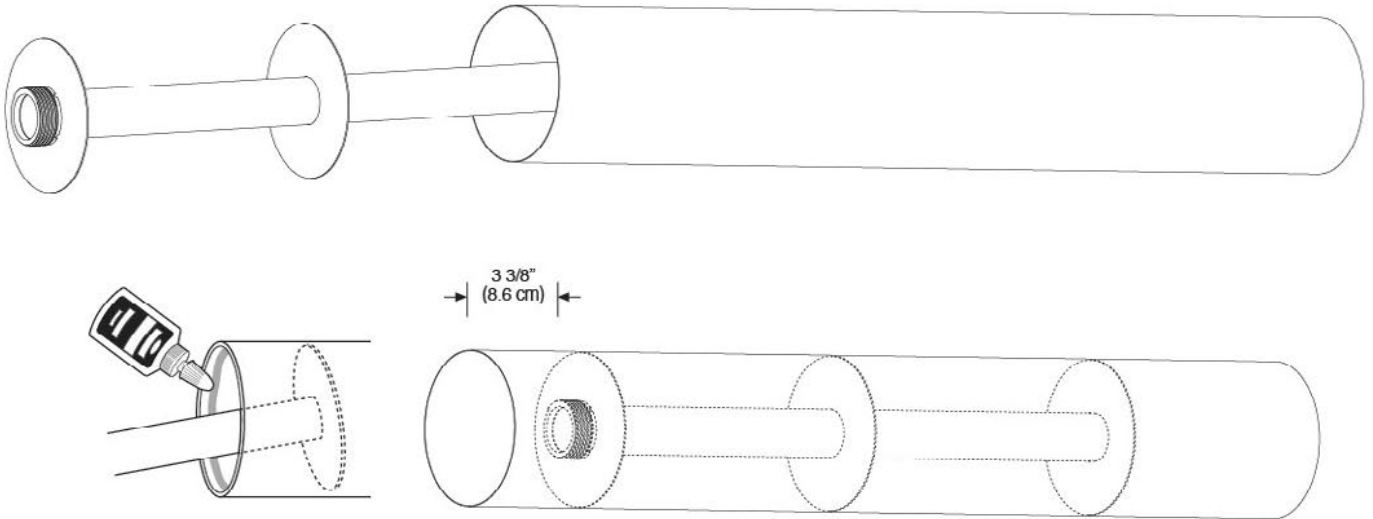

2. Apply a bead of glue around inside of tube assembly at rear of tube as shown. Insert reinforcing ring inside of tube assembly leaving $\frac{3}{4}$ " (19 mm) of tube assembly exposed. Let dry.

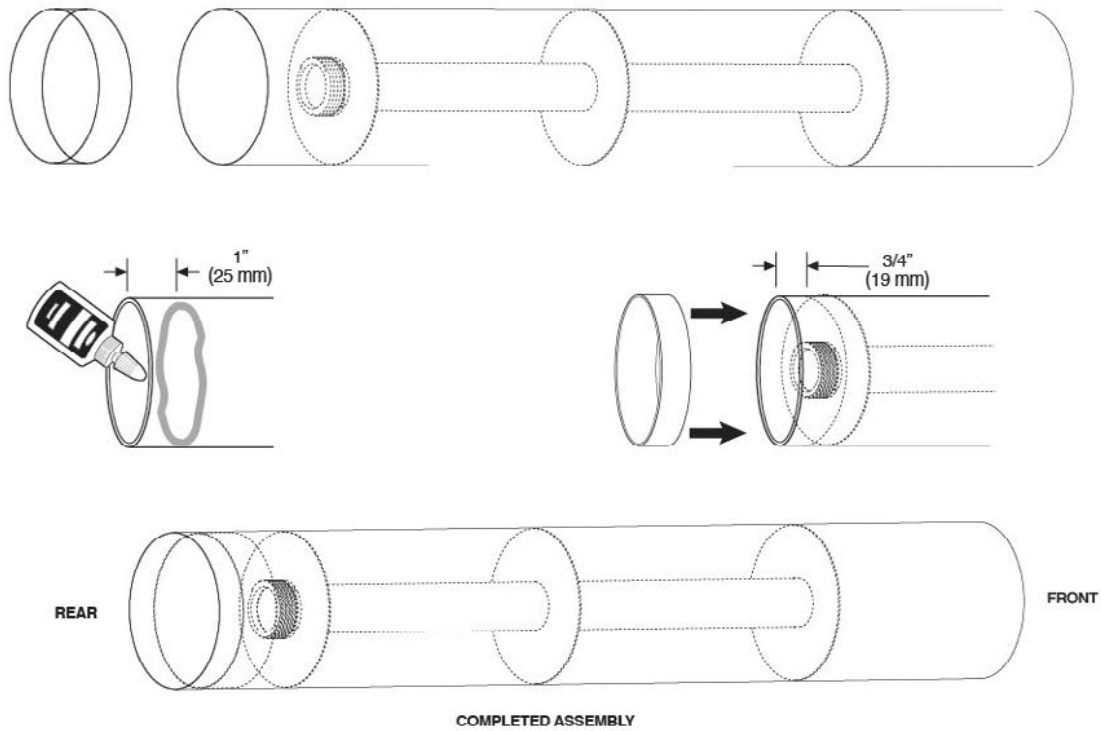

3. Carefully extend the marks you made on the main body tube alignment line all the way around the tube, making sure the rings you draw are straight. (Use a thick piece of paper or masking tape as an aid in drawing the rings.)

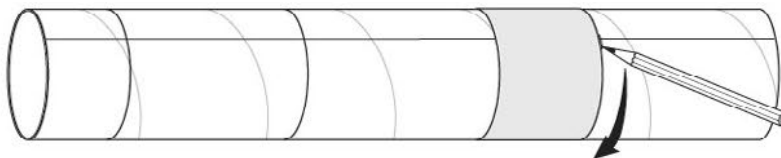

INSTALL THIRD STAGE CENTERING RINGS

1. Carefully remove the third stage centering rings from their laser-cut card.

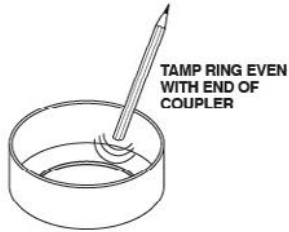
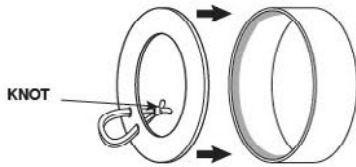

4. Align the reference line you drew earlier on the third stage body tube with the string loop, and glue the tube into the coupler assembly. (Be sure to note the front of the tube.) Let dry.

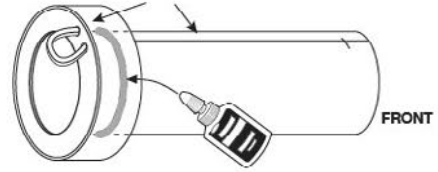

2. Cut a piece of line 5" (12.7 cm) long, double it, and thread the ends into the holes in the laser-cut ring as shown. Test fit and glue the ring into the main body coupler so that the knot is on the inside of the coupler and the ring is flush with the coupler edge.

3. Glue the other ring into the other end of the coupler so that it is flush with the coupler edge.

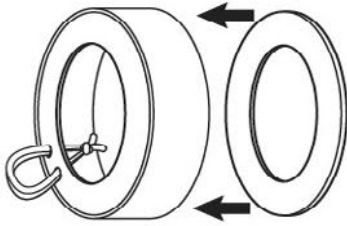

5. Glue the center from one of the laser-cut rings onto the bottom of the tube/coupler assembly.

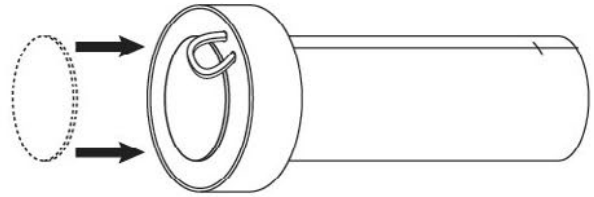

INSTALL THIRD STAGE FOUNDATION WRAP

1. Carefully cut along the outside edges of the third stage foundation wrap and glue tab. Curl the wrap, use low tack masking tape to tape the ends together, and glue the tab to the inside seam leaving about 1/16" (2 mm) of clearance at both the top and bottom as shown. Let dry.

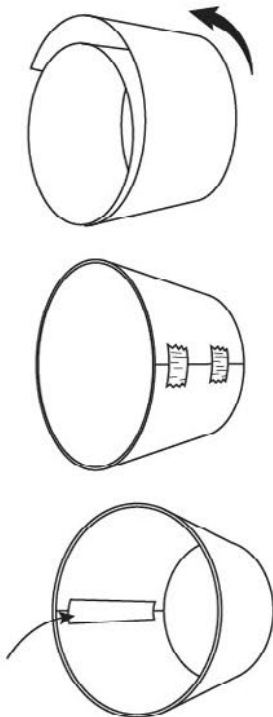

2. Slide the wrap onto the coupler, draw a line around the body tube at the front of the wrap, and remove. Apply a ring of glue around the tube at the mark, and slide the wrap back into place making sure to align the seam in the wrap with the alignment line on the tube.

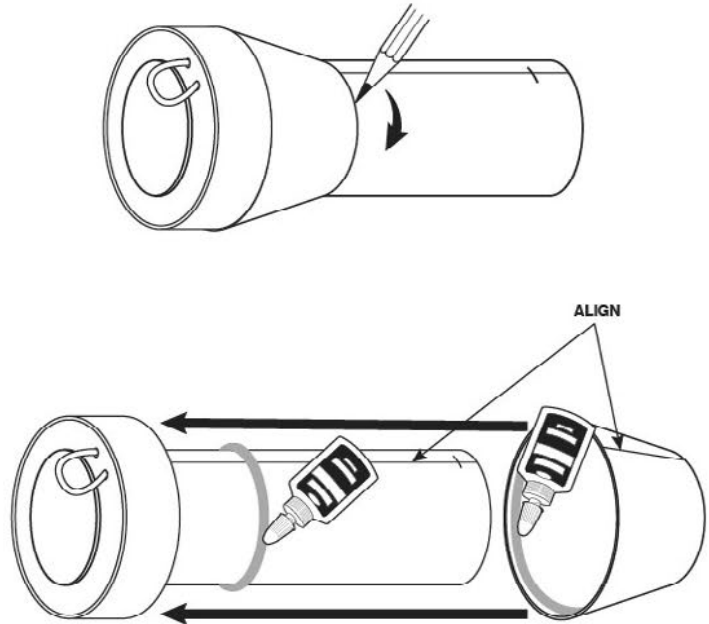

APPLY TUBE WRAPS

1. Orient wraps according to the diagram and lightly mark the top of each wrap for later reference. Be sure to note and mark the top of the intertank wrap before removing from sheet. Use a hobby knife to carefully remove the vac-form wraps from the excess plastic cutting along the corrugation on the left side and leaving some excess plastic on the right. Test fit and trim as necessary. Use the dimensions shown to cut the lower 1st stage wrap from the vac-form sheet.

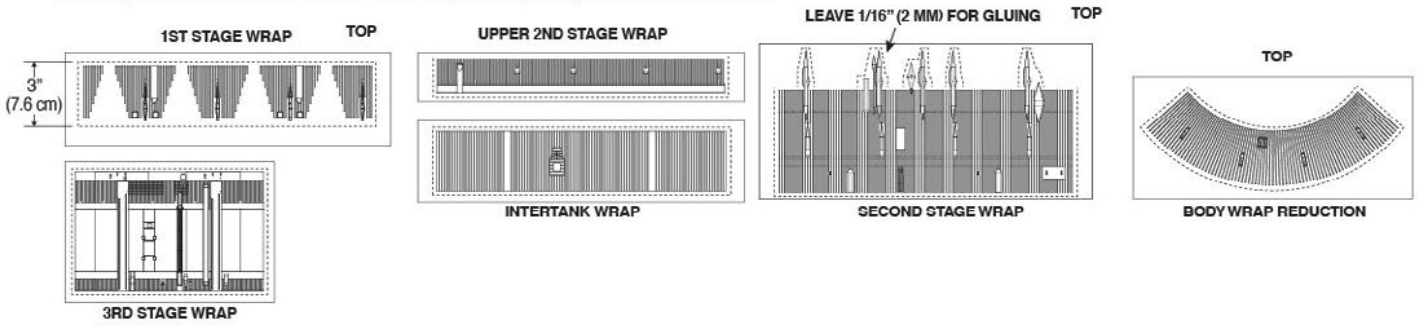

2. Lightly spray the lower 1st stage wrap with spray adhesive, align the edge of the wrap with the alignment line on the main body tube, and apply wrap to the 3" (7.6 cm) ring you drew earlier.

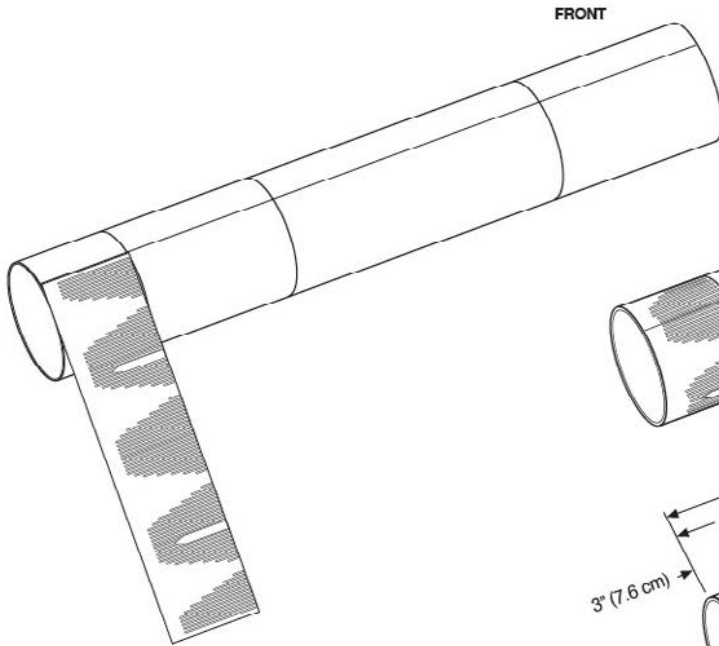

3. Once dry, extend alignment lines along each side of the two tunnels on the vac-form wrap for 11" (27.9 cm). Use these lines as guides and affix the intertank and second stage wraps. (Be sure your tunnel locations line up).

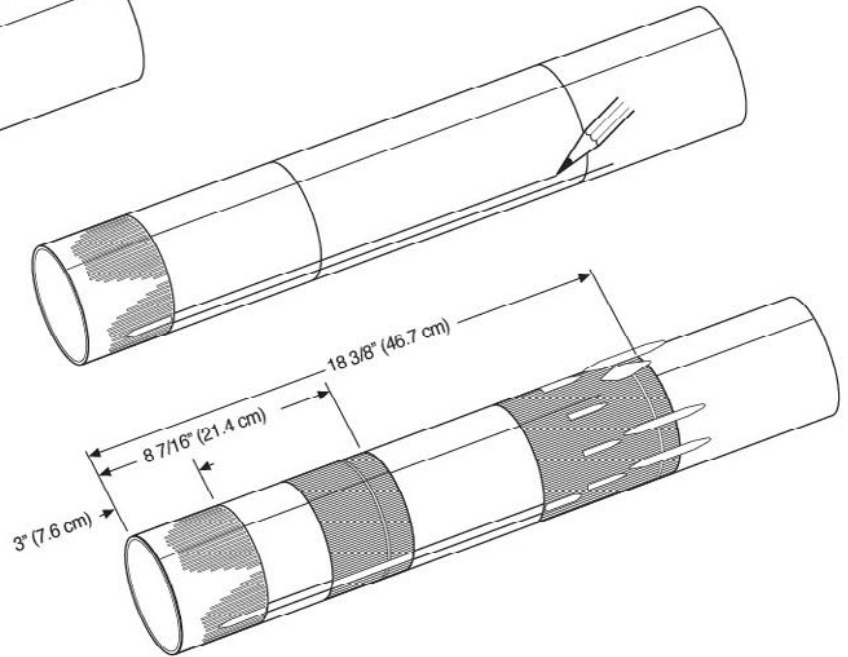

4. Once the second stage wrap is dry, extend 6" (15.2 cm) alignment lines from the sides of the forward tunnel to use as guides and apply the upper second stage wrap.

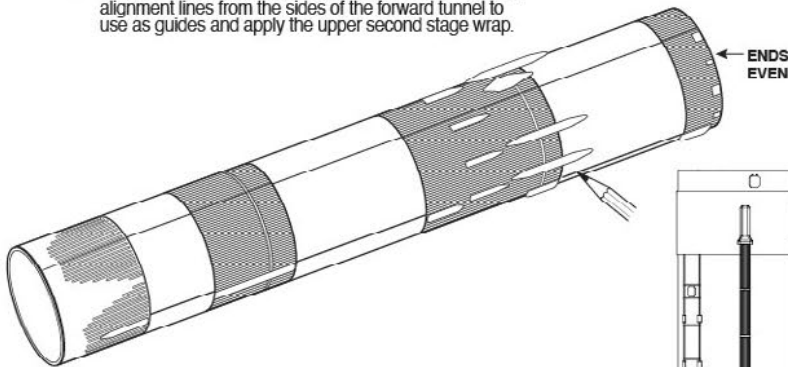

5. Apply the upper third stage wrap to the third stage body tube shown on the third stage assembly. Apply reduction wrap where shown on the third stage assembly.

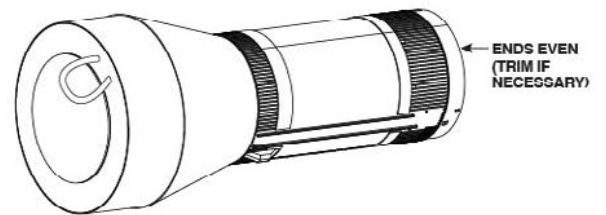

Align this feature of lower wrap with this feature of upper wrap.

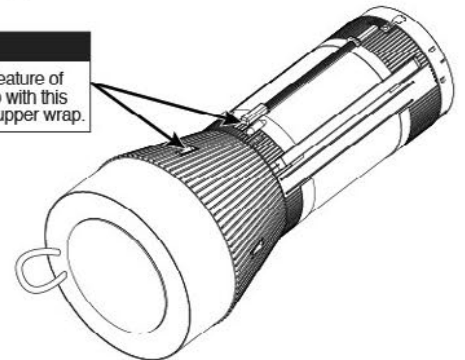
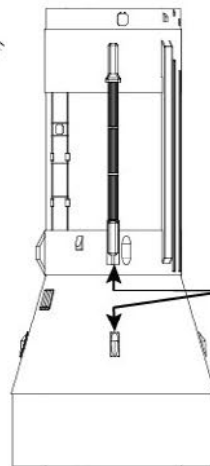

ASSEMBLE FINS

1.



2. Let dry

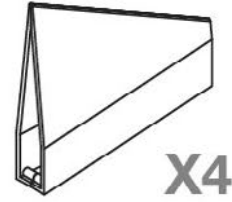

X4

PREPARE FAIRINGS

1. Use a hobby knife to carefully remove the fairings, leaving 1/16" (2 mm) of flash.

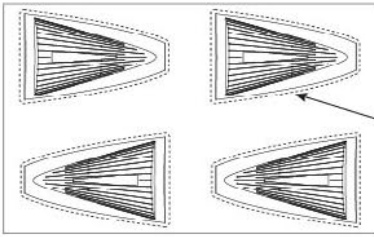

1/16" (2 mm)

2. Use a hobby knife to carefully remove the fairing bases and the alignment guide.

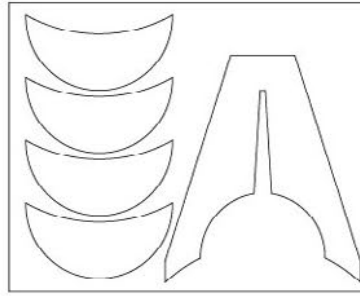

3. Use plastic cement to attach the fairing bases to the inside bottom of the fairings.



4. Let dry.

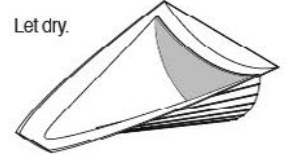

5. Use a hobby knife to carefully remove the flashing from the fairings.

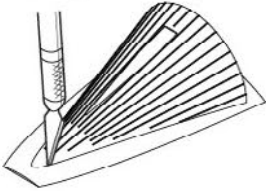

6. Remove the fin slot indentations and bottom ledge from each fairing.

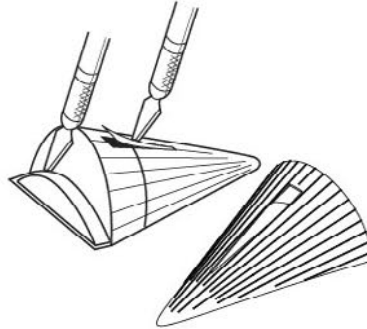

7. Test fit, trim, and sand each fairing to fit each fin and each fairing to fit on the lower first stage wrap.

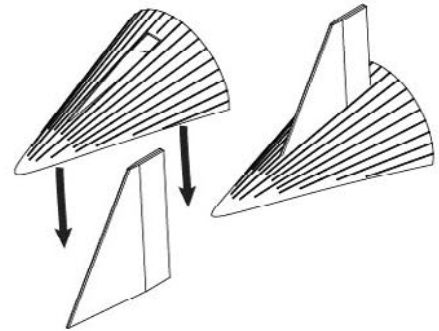

8. Test fit fin and shroud at location shown. Use card stock alignment guide for correct positioning.

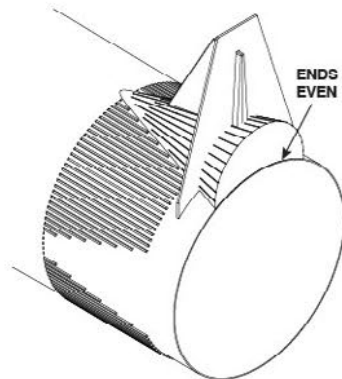
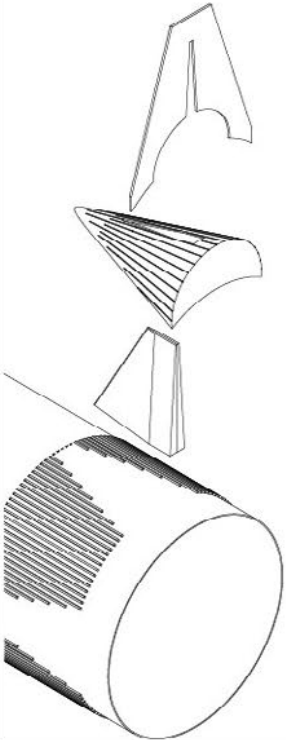

ENDS
EVEN

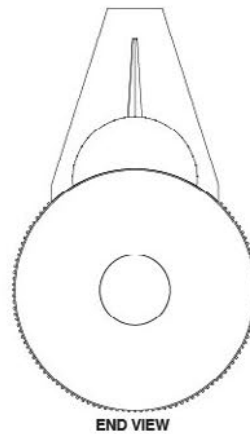

END VIEW

9. Trim as needed for a perfect fit.

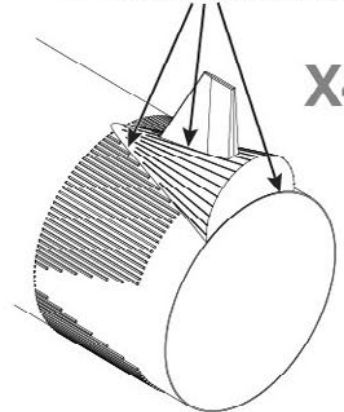

X4

ATTACH FINS AND FAIRINGS

1. Apply plastic cement to root edge of fin. Use shroud and card stock alignment guide for correct placement.

2. Hold in place until glue sets.

3. Remove fairing and apply glue fillet around fin joint.

4. Apply plastic cement as indicated and replace fairing.

5. When fins and fairings are dry, apply a reinforcing coating of liquid cement to the fin, fairing, and wrap joints. Let dry. Fill any holes with putty and sand flush.

6. Once the fairings are permanently affixed, cut away the areas on the tube where shown.

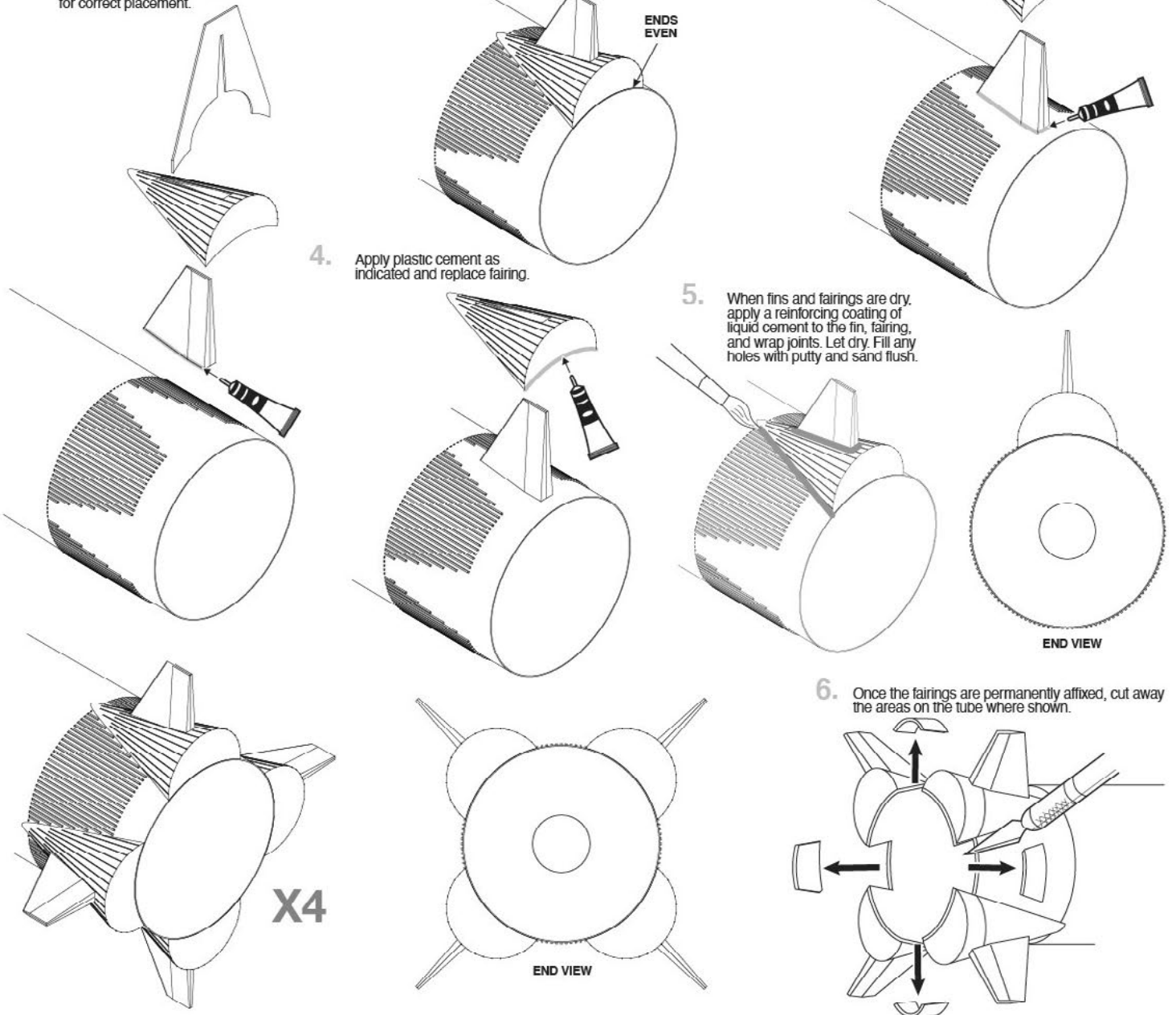

X4

ATTACH PLASTIC TUNNELS

1. Mark and cut the half round tunnels to continue between the 1st stage wrap and intertank wrap (both sides), between the intertank and second stage (both sides), and between the second stage and upper 2nd stage (one side), then use plastic cement to apply to body tube.

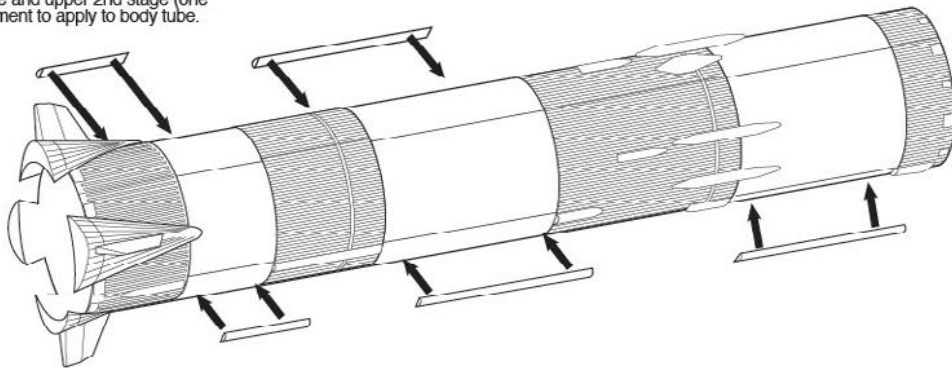

INSTALL CLAY NOSE WEIGHT

1. Roll clay into "snakes".

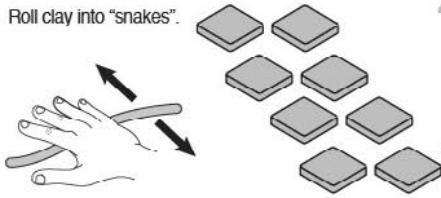

2. Insert "snakes" into nose cone.

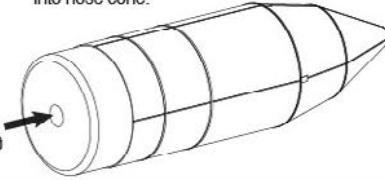

3. Use dowel rod, launch rod or similar tool to compress clay into tip of nose cone.

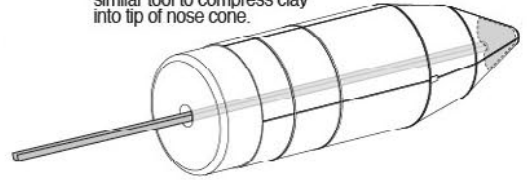

COMPLETE UPPER STAGE

1. Use plastic cement to glue the plastic solar array wing parts to the 3rd stage wrap.

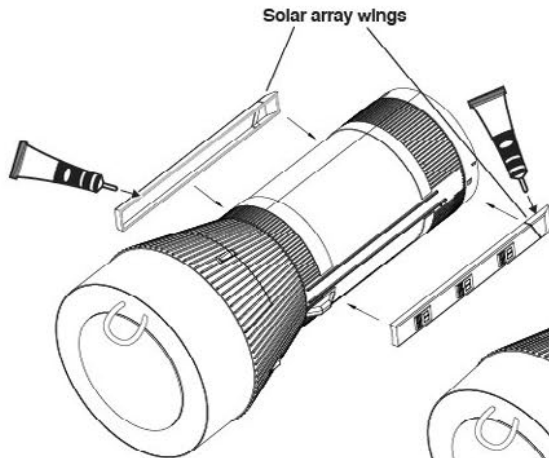

Solar array wings

- 2.

Do not permanently glue in place until the final balance of the model is performed. See page 12 for the center of gravity balance point.

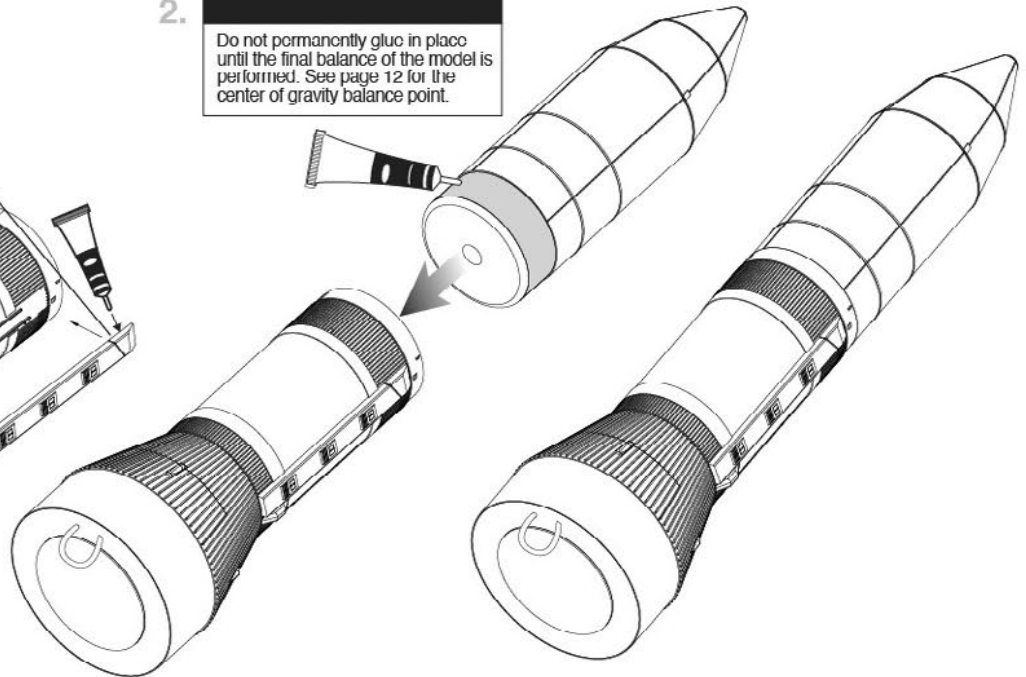

You may want to wait to glue these pieces together until after they have been painted.

ASSEMBLE AND INSTALL NOZZLES

1. Use a hobby knife to remove and trim the nozzle halves and supply tubes from the plastic tree. Use liquid plastic cement or plastic CA to glue the nozzle halves together, and then to attach the supply tubes. Be sure to note that the middle (heavy) portion of the tubes point down toward the nozzles. Hold tubes in place until cement sets, check that tube is straight, and let dry.

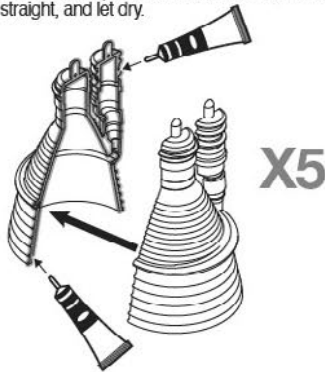

X5

2. Paint the nozzle assemblies silver and let dry overnight.

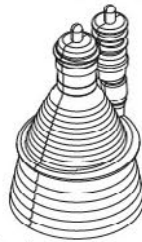

3. Use a hobby knife to remove the bulkhead from its laser-cut card. Position the bulkhead over the nozzles. Place the plastic washers over the nozzle hubs on bulkhead. Use the spacer ring to press the bulkhead down onto nozzles and to ensure that the nozzles all sit evenly on a flat surface. You will notice that the spacing between the spacer ring and the washers is tight. Position the washers so that they do not interfere with the fit of the spacer ring to the bulkhead.

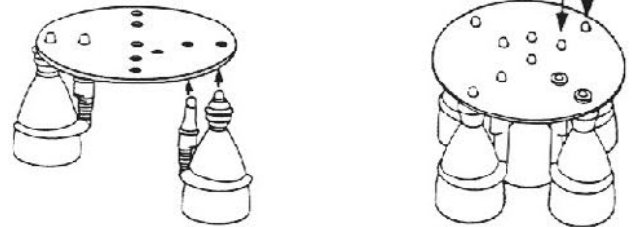

4. Use liquid plastic cement or plastic CA to glue the washers in place and let dry.

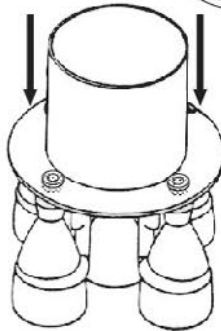

5. Remove the spacer ring, apply yellow glue and reposition on bulkhead

For display purposes only. Remove for flight.

INSTALL LAUNCH LUGS

If you do not intend to fly your Saturn V, you may want to skip this step as launch lugs are only necessary on a flight model.

1. Use plastic cement to glue the launch lugs over the alignment line on the main body tube 1/4" (6 mm) below the second stage wrap and just above the first stage wrap as indicated. Let dry.

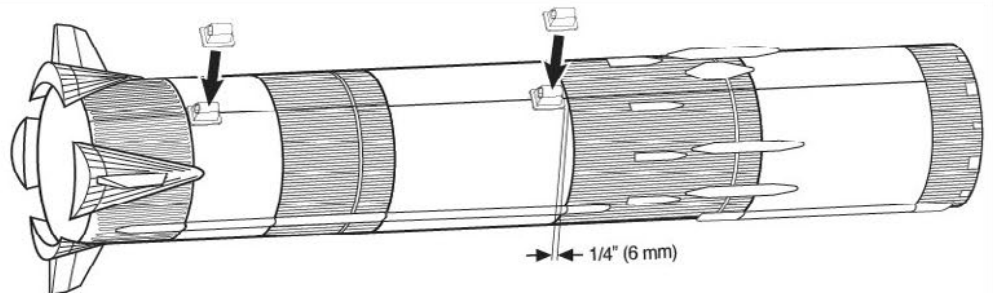

← 1/4" (6 mm)

INSTALL SHOCK CORD MOUNTS

1. Test fit the separate sections of the body together, and sand as necessary to achieve a good fit
2. Cut out the two shock cord mounts on card 083591. Fold.
3. Lay shock cord onto shock cord mount at an angle as shown and apply glue to section two. Fold section 1 over
4. Apply glue to section 3. Fold forward again. Clamp firmly until glue sets. Repeat for the other shock cord and mount.
5. Apply glue to each mount and apply mounts to opposite sides of the main body tube at least 2" (5.1 cm) down
6. Tie a double knot at the free end of each shock cord.

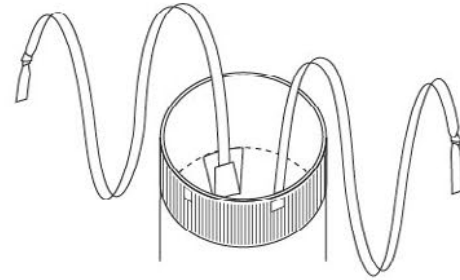
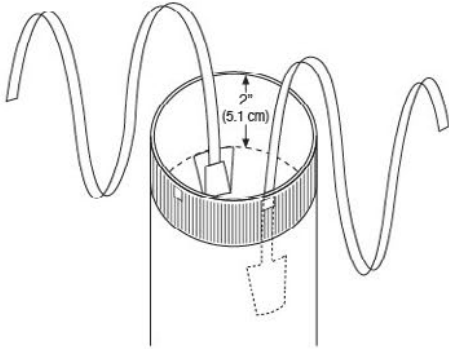
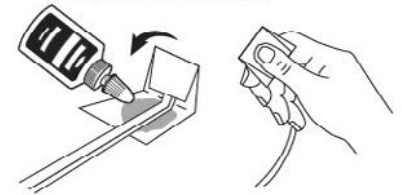
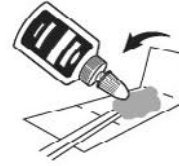
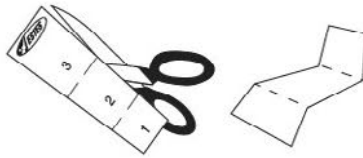

PREPARE RECOVERY SYSTEM

1. Build all three parachutes according to the instructions printed on the parachute borders.
2. Form a loop in the shroud lines of one of the 24" (61 cm) parachutes and lay a mounted shock cord over loop.
3. Pass parachute through loop and pull tight. Repeat with the other 24" (61 cm) parachute and mounted shock cord.

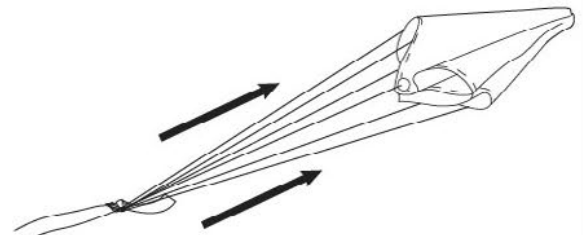
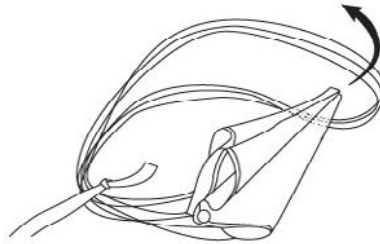
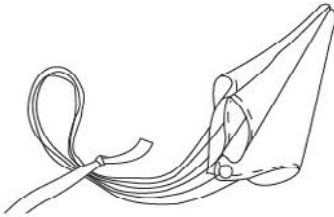

PREPARE THIRD STAGE RECOVERY SYSTEM

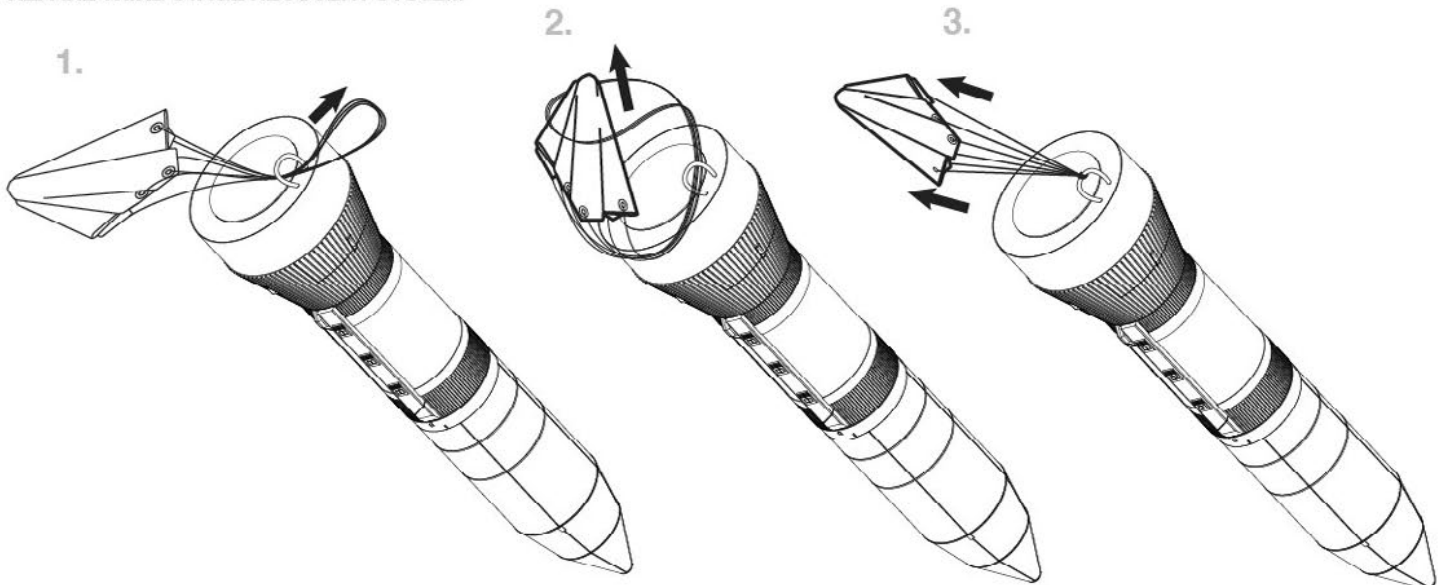

PAINT ROCKET

Before painting, check that all parts are firmly attached, and that any small gaps have been filled using putty or glue. If you did not fill the spirals in the body tubes earlier, do so now. Spray adhesive can be removed with a tissue dipped in enamel thinner (use sparingly!), and wood glue or CA can be removed using a fine grain sandpaper. If you do not wish to mask off the model, you may spray the entire model white, then use bottle paint for the black and silver (or gunmetal) areas. Again, **DO NOT USE LACQUER BASED PAINTS**. They will attack the plastic parts of your Saturn V. If you have any doubt about the paints you wish to use, use a piece of scrap plastic as a test surface.

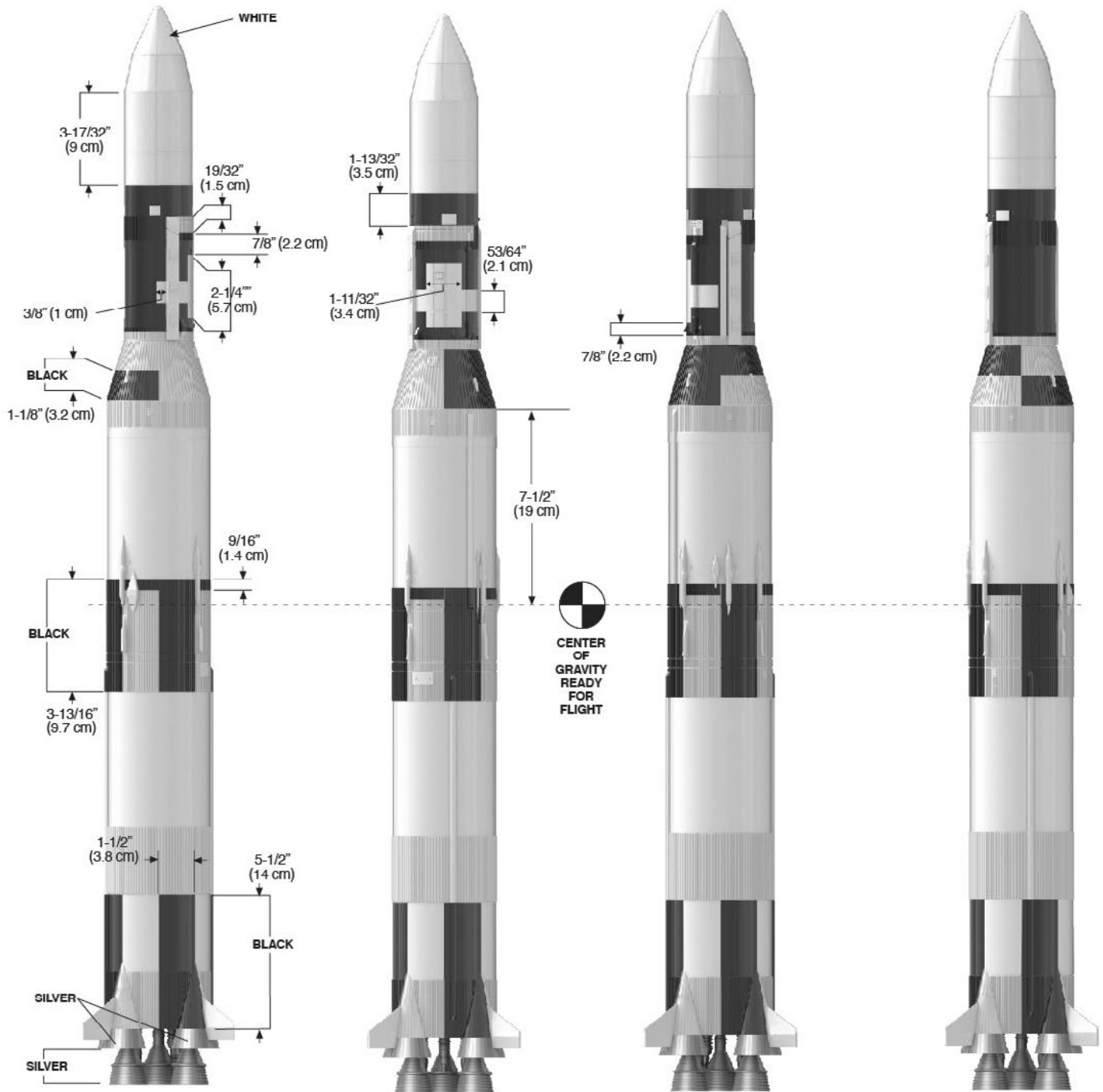

PREPARE FLIGHT RECOVERY

1. Crumple and place four squares of recovery wadding into the front of engine mount tube.
2. Lay six squares of wadding flat in the bottom of parachute compartment.

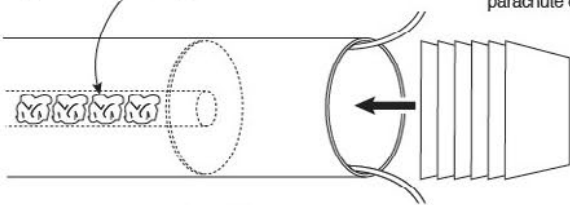

3. Spike, fold, and roll the 24" (61 cm) parachutes and insert into parachute compartment.

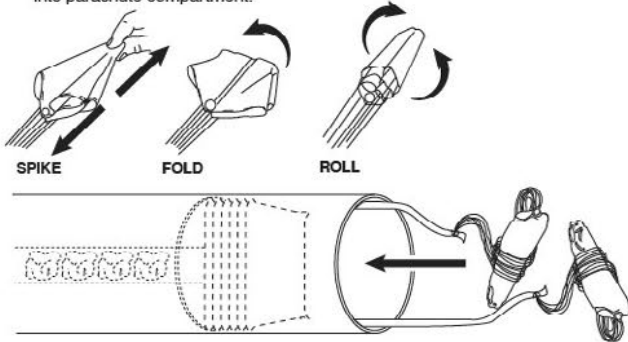

4. Lay two flat squares of wadding on top of parachutes.

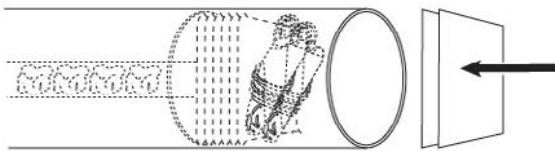

5. Fold and roll the forward section parachute, and lay parachute on the wadding in the middle of the parachute compartment. Insert the forward section into the main body tube, and twist back and forth to make sure the sections do not bind. Sand if necessary.

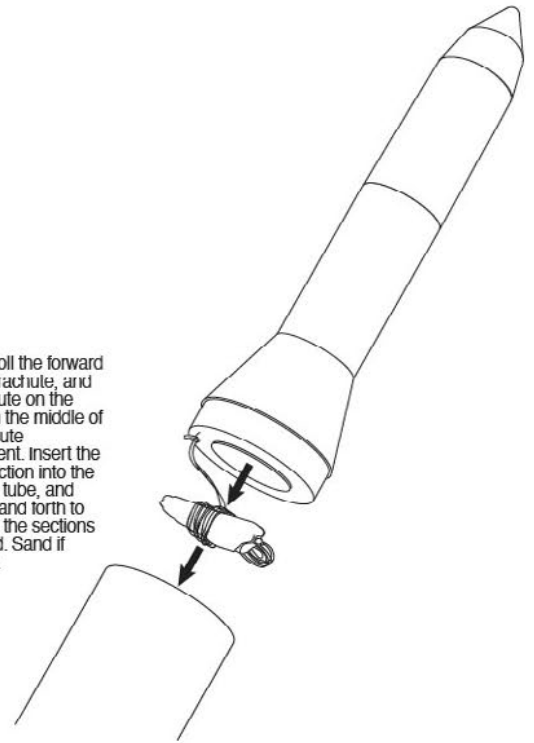

PREPARE ENGINE RETENTION

1. Wrap 6 to 8 layers of masking tape over nozzle end of motor. Overlap end of engine by 1/4 inch (6 mm).

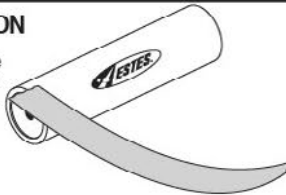

2. Trim off excess tape.

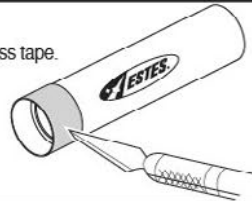

- 3.



PREPARE ENGINE

- 1.

ENGINE

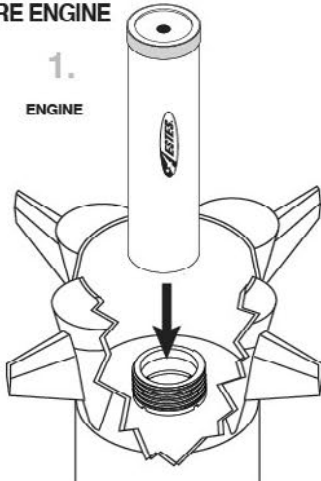

STARTER

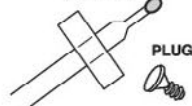

Use 1 each.

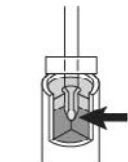

TIP MUST TOUCH PROPELLANT!

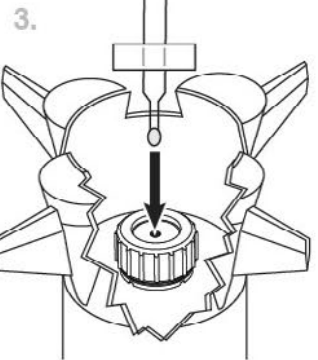
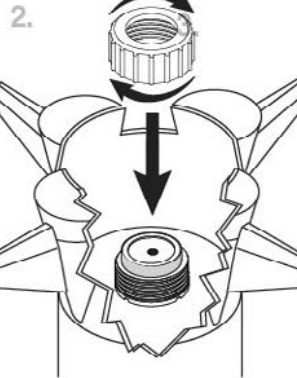

- 4.

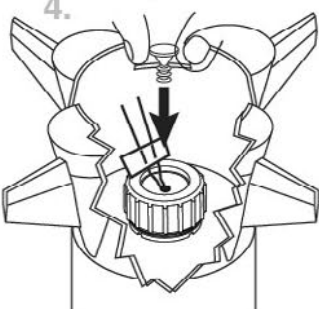

- 5.

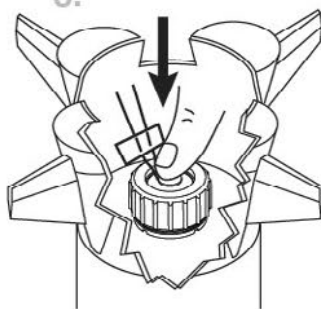

- 6.



To avoid serious injury, read instructions & NAR Safety Code included with engines. **PREPARE YOUR ENGINE ONLY WHEN YOU ARE OUTSIDE AT THE LAUNCH SITE PREPARING TO LAUNCH.** If you do not use your prepared engine, remove the starter before storing your engine.

SEE OUR ENTIRE FLEET OF SCALE KITS AT
estesrockets.com



2056
U.S. Army Patriot M-104



3228
V2



1293
Black Brant III



1921
Mercury Redstone 4
Liberty Bell 7



7000
Bull Pup 12-D



7255
Little Joe I



9720
Doorknob



2446
Mini Honest John

Rockets not to scale with each other.

COUNTDOWN AND LAUNCH

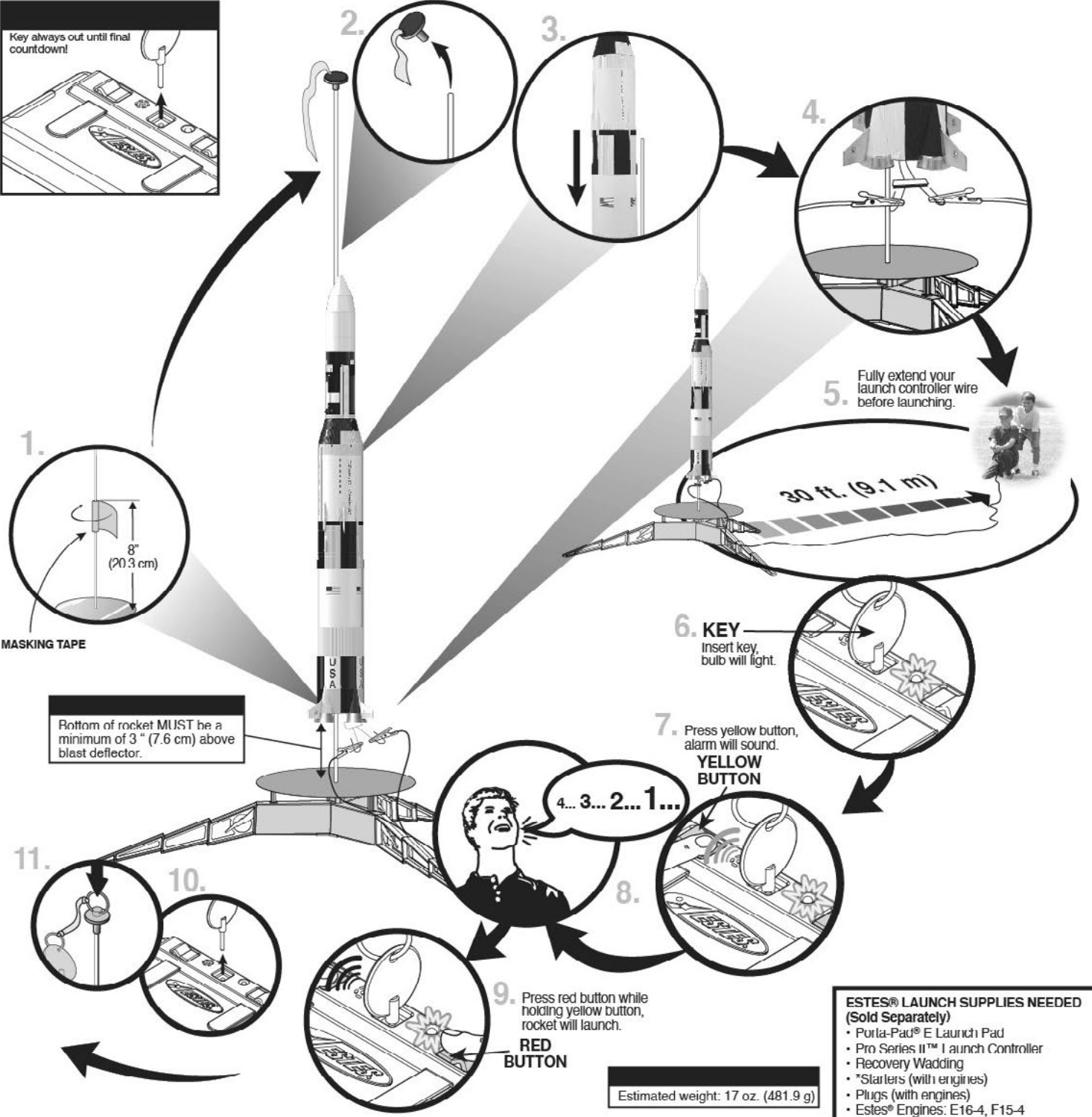

- ESTES® LAUNCH SUPPLIES NEEDED (Sold Separately)**
- Porta-Pad® E Launch Pad
 - Pro Series II™ I Launch Controller
 - Recovery Wadding
 - *Starters (with engines)
 - Plugs (with engines)
 - Estes® Engines: E16-4, F15-4

PRECAUTIONS



PRE-LAUNCH CHECK For safety, never launch a damaged rocket. Check the rocket's body, nose cone and fins. Also, check the engine mount, recovery system and launch lug(s). Repair any damage before launching the rocket.

FLYING YOUR ROCKET Choose a large field (500 ft [152 m] square) free of dry weeds and brown grass. The larger the launch area, the better your chance of recovering your rocket. Football fields and playgrounds are great. Launch only with little or no wind and good visibility. Always follow the National Association of Rocketry (NAR) SAFETY CODE.

MISFIRES TAKE THE KEY OUT OF THE CONTROLLER. WAIT ONE MINUTE BEFORE GOING NEAR THE ROCKET. Disconnect the micro-clips and remove the engine. Take the plug and starter out of the engine. A burned starter means the starter tip was not touching engine propellant. Install a new starter; be sure the tip is touching propellant inside the engine. Push the plug in place. Repeat steps under Countdown and Launch.