

NOTE:
Always keep the key **OUT** until final countdown.

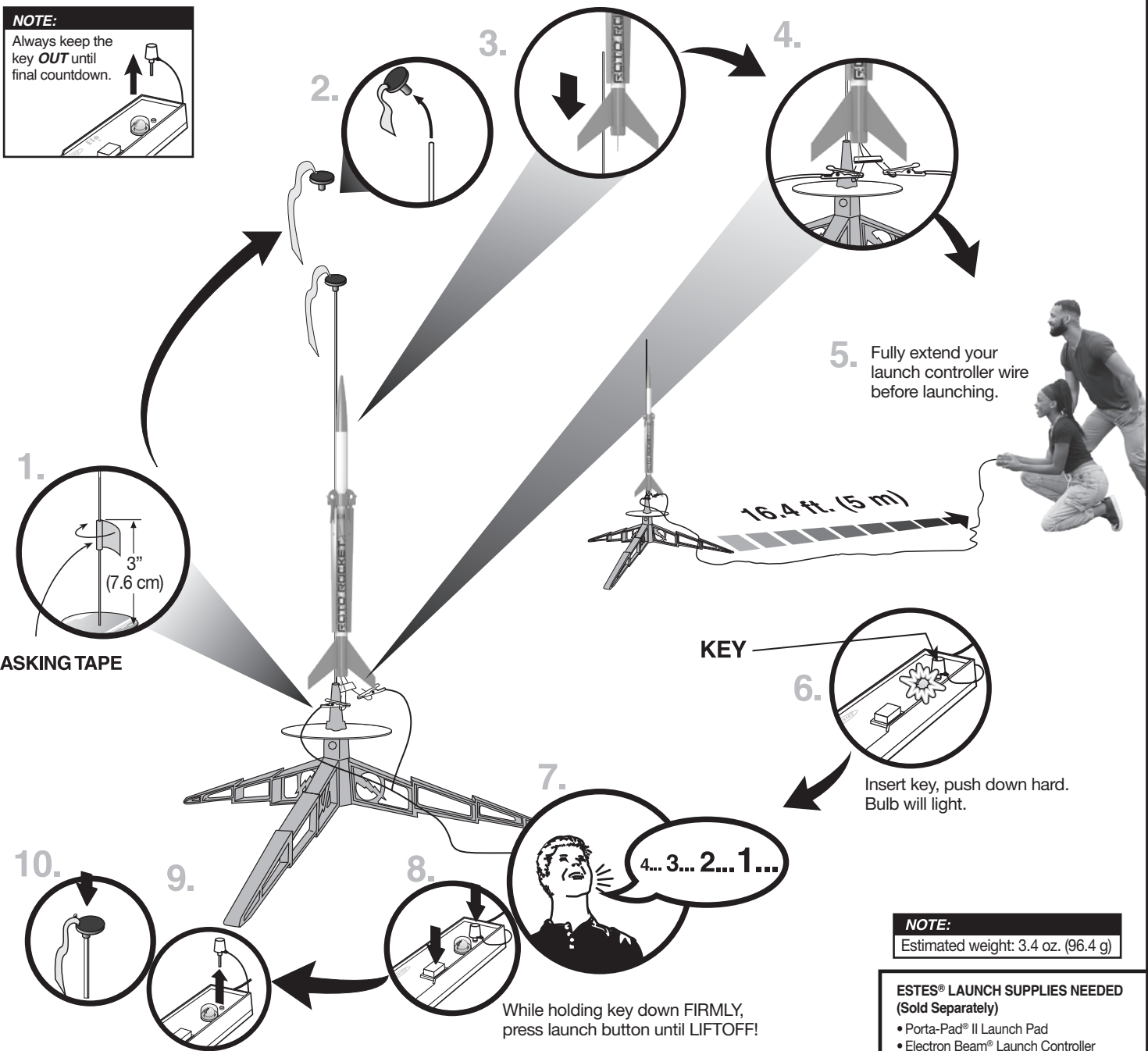

NOTE:
Estimated weight: 3.4 oz. (96.4 g)

- ESTES® LAUNCH SUPPLIES NEEDED (Sold Separately)**
- Porta-Pad® II Launch Pad
 - Electron Beam® Launch Controller
 - Recovery Wadding
 - Starters (with engines)
 - Plugs (with engines)
 - Estes® Engines: C5-3, C6-3

PRECAUTIONS



PRE-LAUNCH CHECK For safety, never launch a damaged rocket. Check the rocket's body, nose cone and fins. Also, check the engine mount, recovery system and launch lug(s). Repair any damage before launching the rocket.

FLYING YOUR ROCKET Choose a large field (500 ft. [152 m] square) free of dry weeds and brown grass. The larger the launch area, the better your chance of recovering your rocket. Launch only with little or no wind and good visibility. Always follow the National Association of Rocketry (NAR) SAFETY CODE (enclosed).

MISFIRES TAKE THE KEY OUT OF THE CONTROLLER. WAIT ONE MINUTE BEFORE GOING NEAR THE ROCKET. Disconnect the micro-clips and remove the engine. Take the plug and starter out of the engine. A burned starter means the starter tip was not touching engine propellant. Install a new starter; be sure the tip is touching propellant inside the engine. Push the plug in place. Repeat steps under Countdown and Launch.



ROTO ROCKET

AGES 10+



Skill Level **BEGINNER**

MODEL ROCKET INSTRUCTIONS

KEEP FOR FUTURE REFERENCE

IMPORTANT: Please record date found on decal and keep for future reference.

READ ALL INSTRUCTIONS. Make sure you have all parts and supplies. Test fit all parts before applying glue. Refer to your glue manufacturer's dry times during build.

SUPPLIES

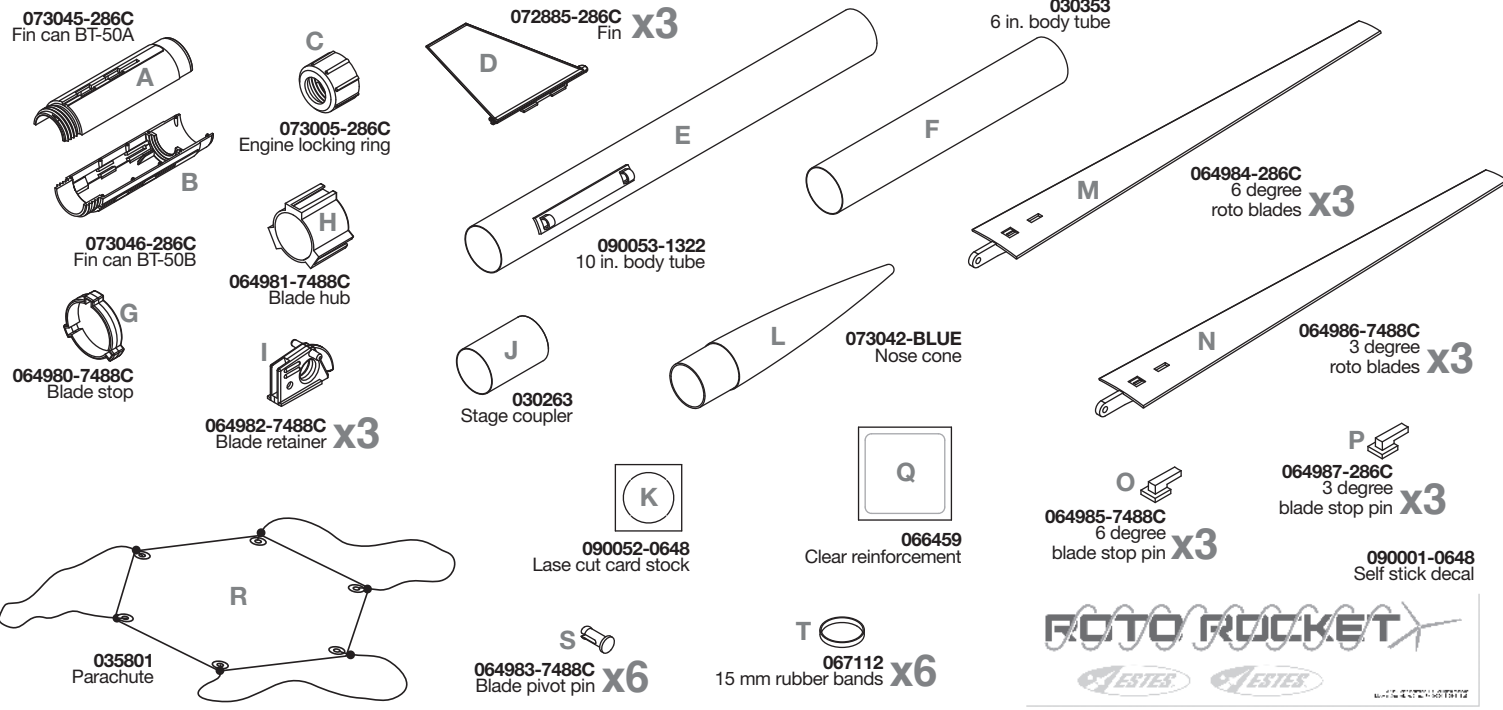
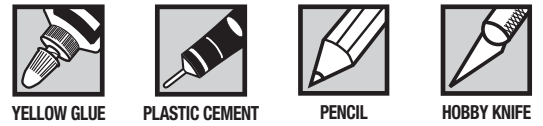

PREPARE FIN CAN ASSEMBLY

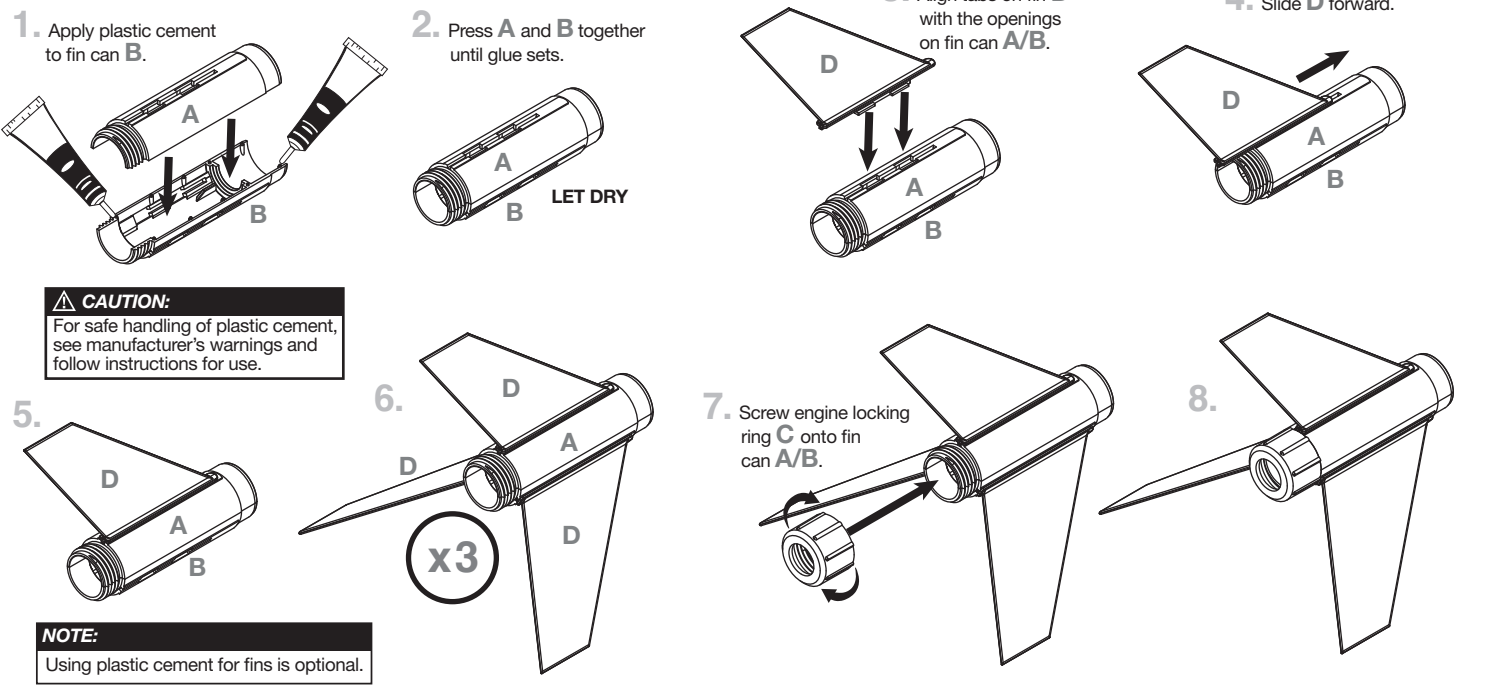

CAUTION:
For safe handling of plastic cement, see manufacturer's warnings and follow instructions for use.

NOTE:
Using plastic cement for fins is optional.

ATTACH FIN CAN TO MAIN BODY TUBE

1. Apply plastic cement to the inside end of body tube E closest to the launch lug.

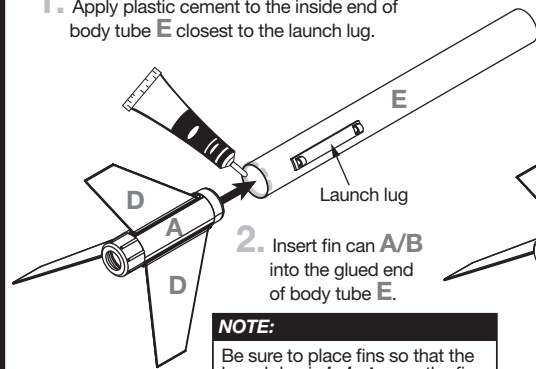

NOTE:
Be sure to place fins so that the launch lug is *in between* the fins.

3. Remove backing from clear reinforcement Q and place over launch lug on body tube E.

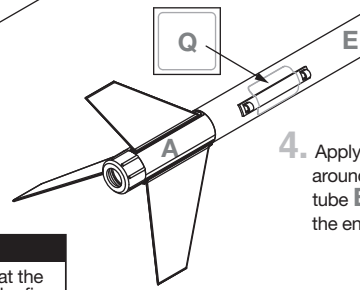

4. Apply plastic cement around outside of tube E 3/4 in. from the end.

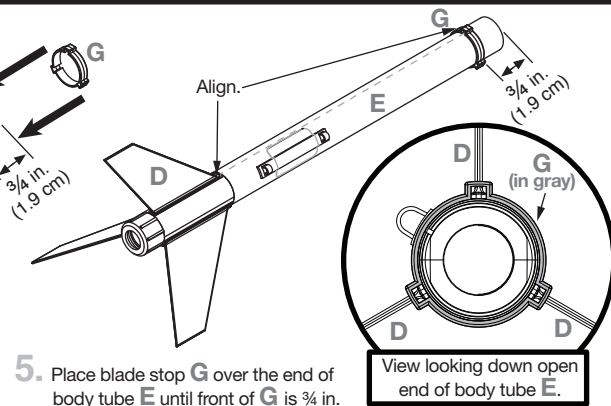

5. Place blade stop G over the end of body tube E until front of G is 3/4 in. distance from front of E. Be sure to align the protrusions on G with the fins D.

View looking down open end of body tube E.

PACKING THE PARACHUTE

1. Push recovery wadding down towards end of the body tube.

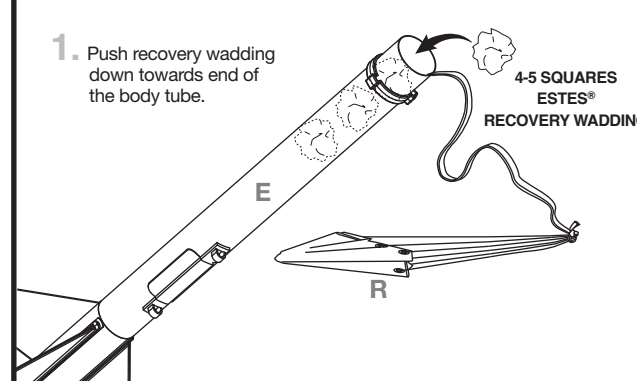

4-5 SQUARES
ESTES®
RECOVERY WADDING

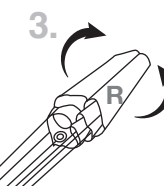
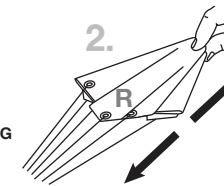

4. Wrap parachute shroud lines loosely around the parachute R and insert into body tube E with the bottom of the parachute going in first.

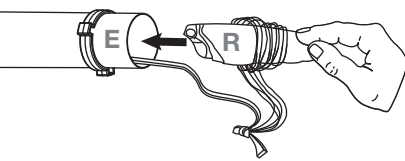

5. Be sure to leave the center tip of parachute R sticking out from tube E slightly.



NOTE:
Recovery wadding and parachute must slide easily into body tube. If too tight, redo.

PARACHUTE ATTACHMENT

1. Pull out the shock cord from inside of body tube E. Do not remove completely, keep other end attached inside body tube.

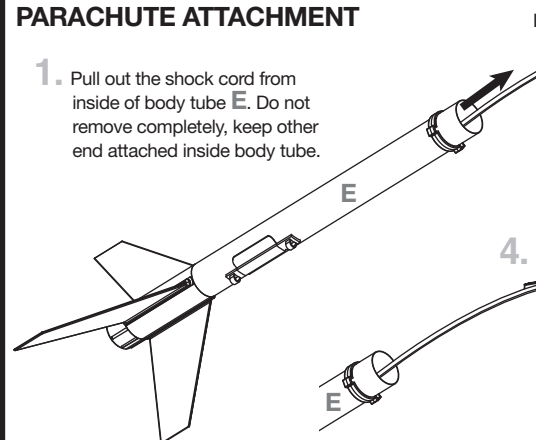

2. Tie a loop at the end of the shock cord.

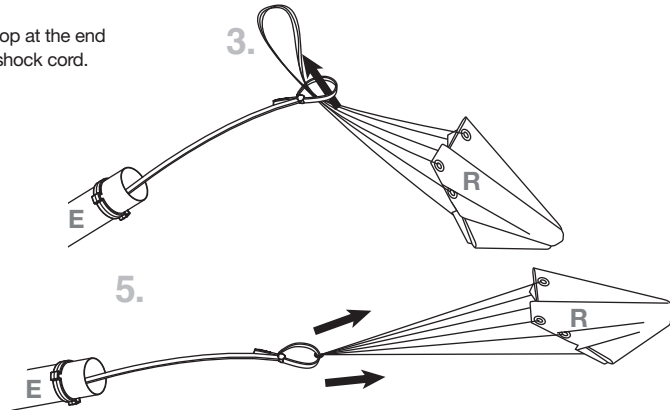

5.

PREPARE NOSE ASSEMBLY

1. Apply plastic cement to the end of tube F.

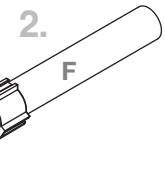
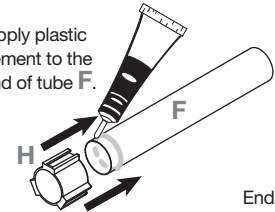

Ends even

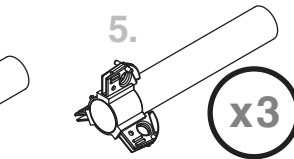
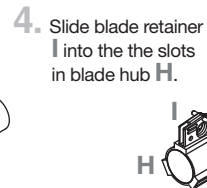

6. Using a hobby knife, cut out the circle in laser cut card stock K.

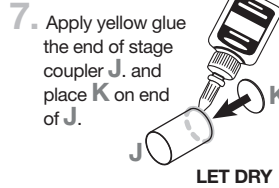
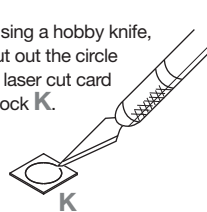

LET DRY

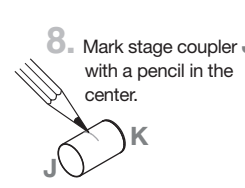

8. Mark stage coupler J with a pencil in the center.

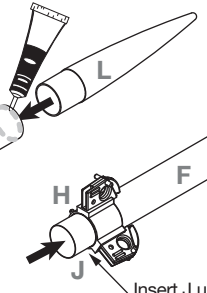
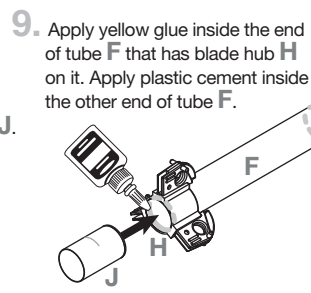

Insert J up to center line.

PREPARE BLADES AND INSTALLATION

1. Apply plastic cement to the opening on the top of roto blade M.

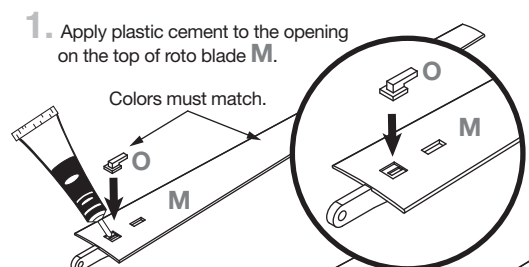

Colors must match.

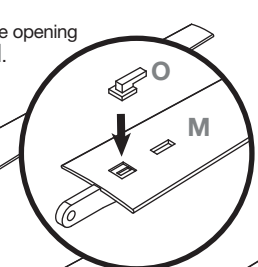

2. Insert blade stop pin O into place.

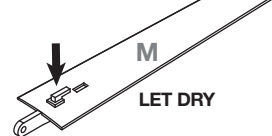

3. Turn roto blade M over, slide end of roto blade into blade retainer I slot and align the hole at the end of the blade with the hole in blade retainer I.

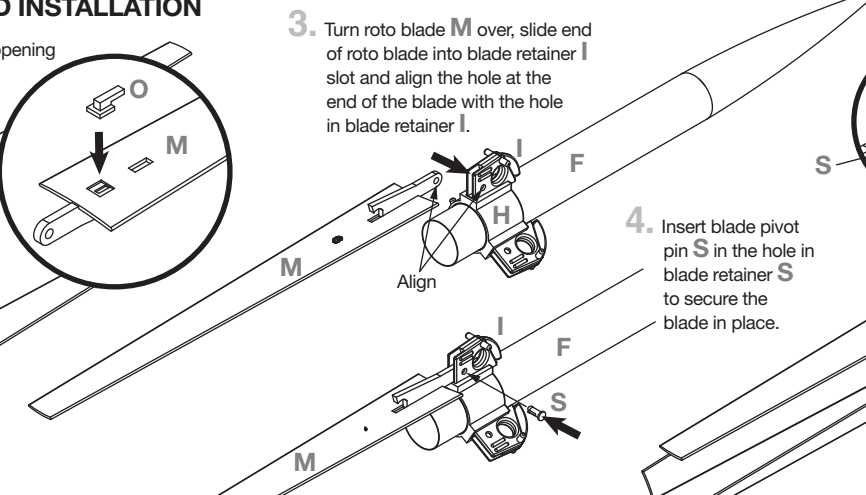

4. Insert blade pivot pin S in the hole in blade retainer S to secure the blade in place.

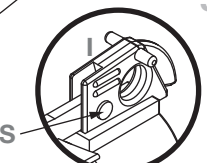

5. Repeat the steps for all three blades. Be sure all three blades are the same color.

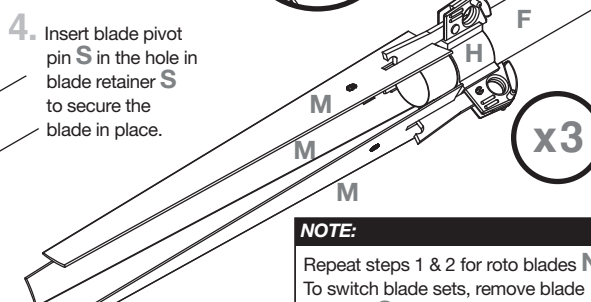

NOTE:
Repeat steps 1 & 2 for roto blades N. To switch blade sets, remove blade pivot pin S and repeat steps 3-5.

PREPARE ENGINE

1. Use one each.

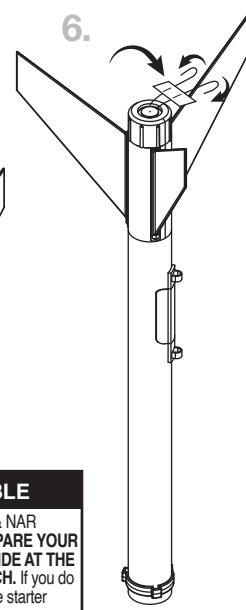
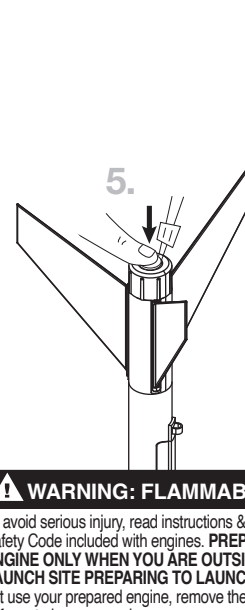
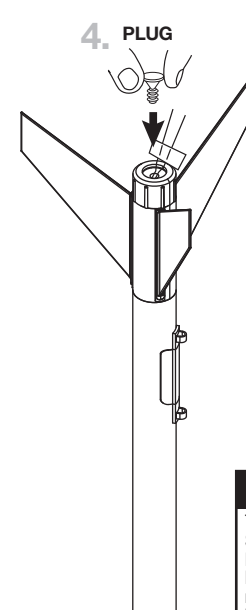
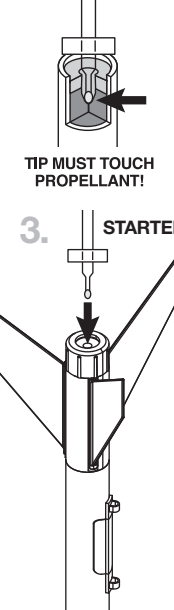
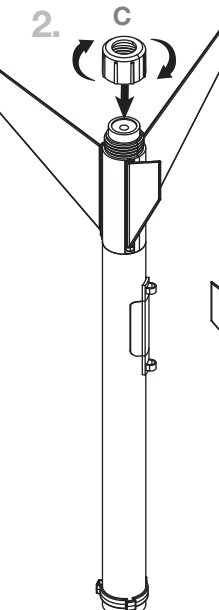
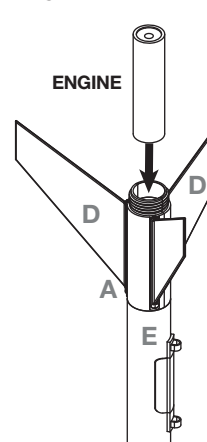
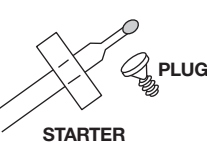

TIP MUST TOUCH PROPELLANT!

WARNING: FLAMMABLE
To avoid serious injury, read instructions & NAR Safety Code included with engines. **PREPARE YOUR ENGINE ONLY WHEN YOU ARE OUTSIDE AT THE LAUNCH SITE PREPARING TO LAUNCH.** If you do not use your prepared engine, remove the starter before storing your engine.

PREPARE BLADES FOR FLIGHT

1. Fold roto blades down. Align the tips of blade stop pin O with the opening of G. Slide nose cone section down into place.

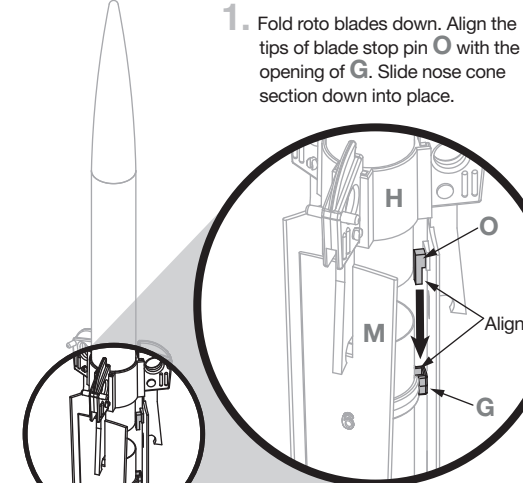

3. Stretch rubber bands T from the notch on the top of blade retainer I, over the guide bars on I, then under the notch on roto blade M.

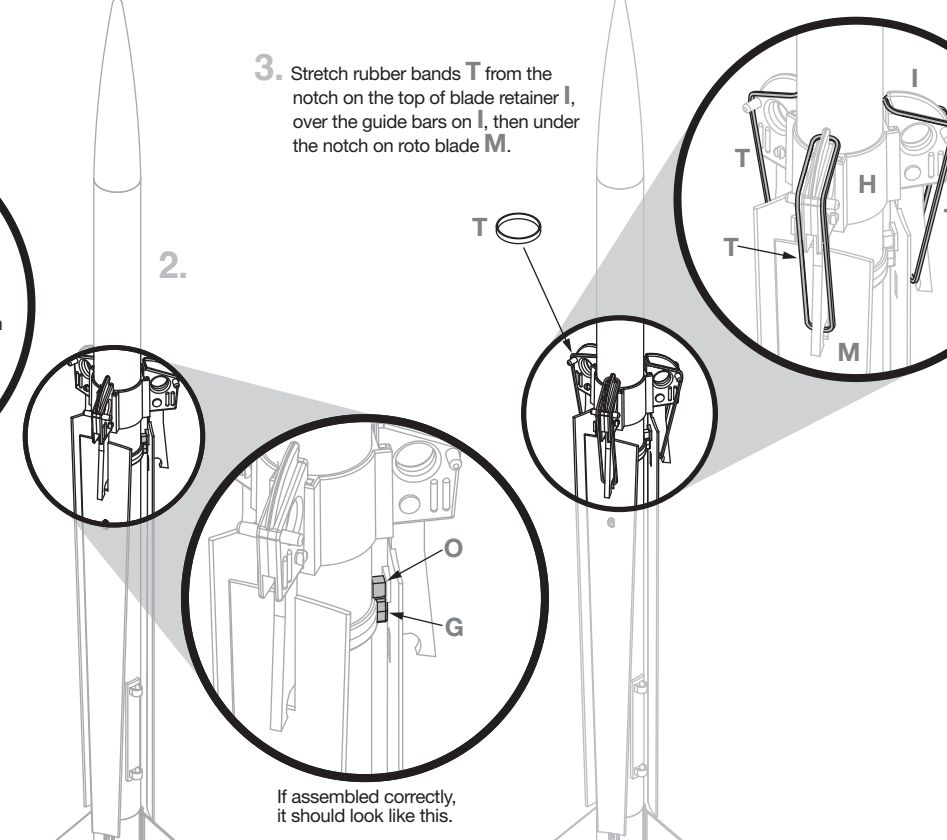

If assembled correctly, it should look like this.