

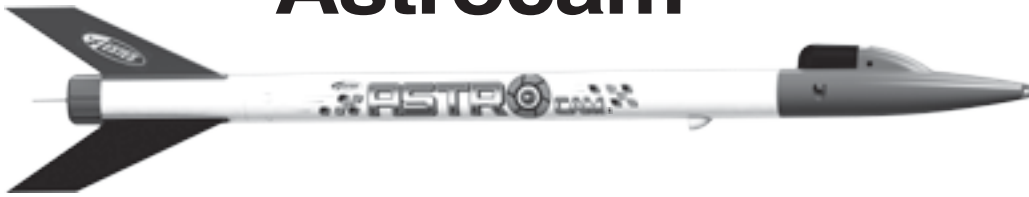

EstesRockets.com

Astrocam®

5325



MODEL ROCKET INSTRUCTIONS

KEEP FOR FUTURE REFERENCE

IMPORTANT: Please record date found on package and keep for future reference.

READ ALL INSTRUCTIONS. Make sure you have all parts and supplies.



090001-5325
Self-stick decal

073211/212
Engine mount
fin can unit
(1 fin slot)

085890
Body tube

073217
Camera/
memory card

072840
Nose cone

073209/210
Shock cord mount/anchor

073113
String

067112
Rubber Bands
X6

038364
Shock cord

072697
Engine retainer cap

072700
Fins

035801
Parachute

ASSEMBLE ENGINE MOUNT FIN CAN UNIT

1. Press firmly together.

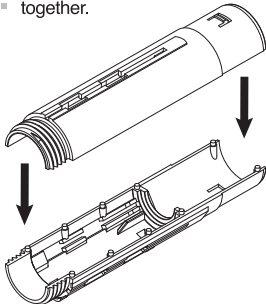

2.

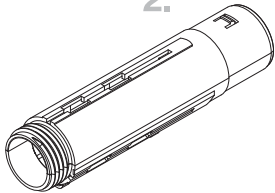

3. Insert fin into slot.

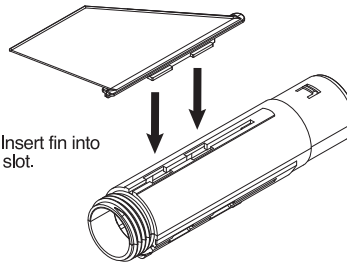

4. Slide fin forward until it stops.

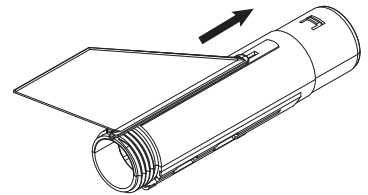

5.

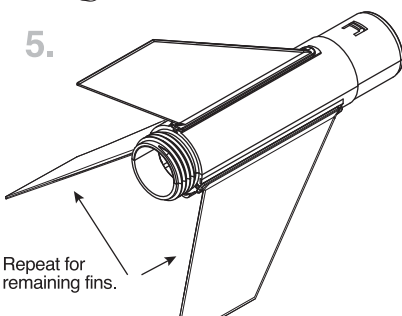

Repeat for remaining fins.

6.

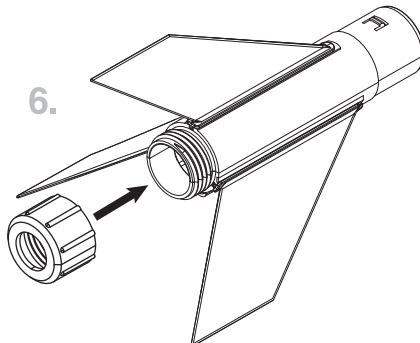

7. Screw engine retainer cap onto fin can unit.

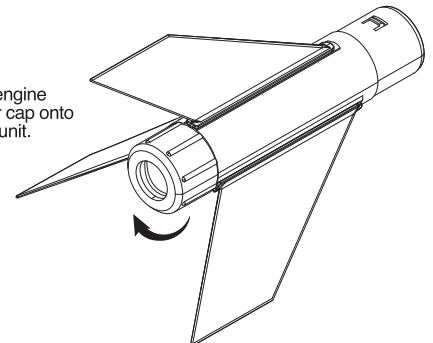

ATTACH BODY TUBE & SHOCK CORD MOUNT

1. Align slots in body tube with notches on fin can unit. Slide body tube over fin can unit until notches on fin can match up with slots in body tube.

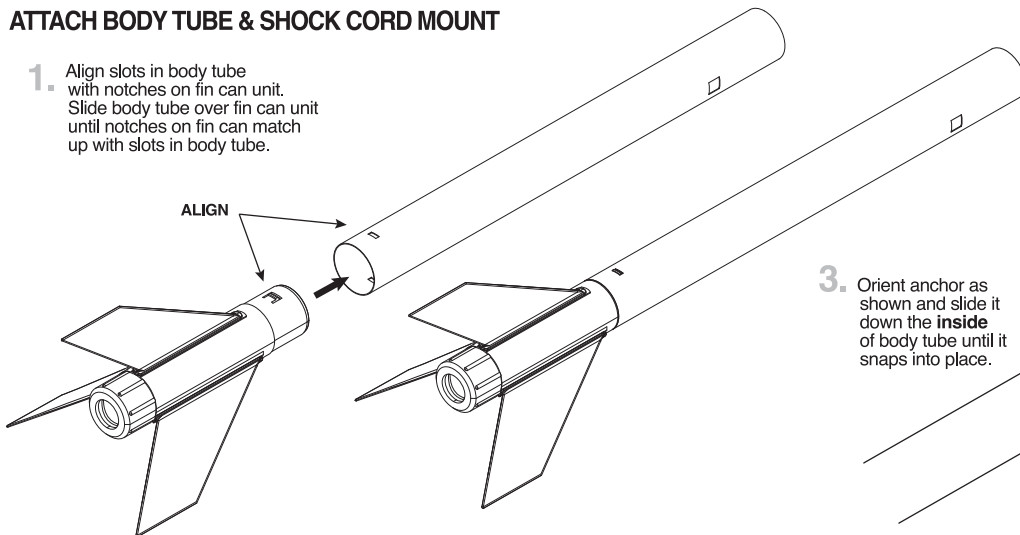

2. Insert mount through square hole.

ROUND END TO FRONT

3. Orient anchor as shown and slide it down the **inside** of body tube until it snaps into place.

NOTE:

You may need a pen or pencil to help push anchor in place.

INSTALL SHOCK CORD

1. Tie double knot in end of shock cord.

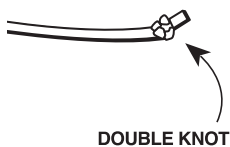

2. Insert **unknotted** end of shock cord through opening of shock cord mount.

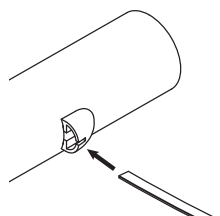

- 3.

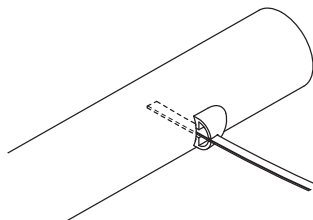

4. Pull on shock cord to confirm knot is snug and won't pull through shock cord mount.

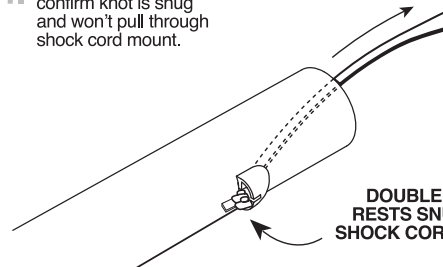

ATTACH PARACHUTE AND SHOCK CORD

1. Attach single string to top of nose cone and tie double knot.

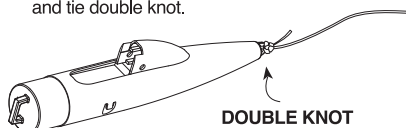

2. On opposite end of single string make a small loop and tie double knot again.

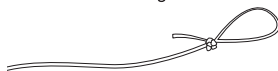

- 3.

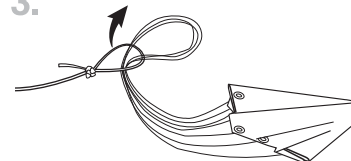

- 4.

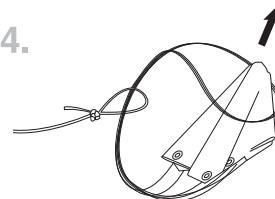

- 5.

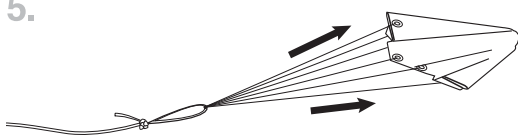

6. Attach shock cord to bottom of nose cone and tie double knot.

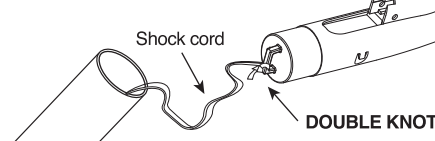

PREPARE FLIGHT RECOVERY

3-4 SQUARES ESTES® RECOVERY WADDING

1. Push recovery wadding down towards end of body tube.

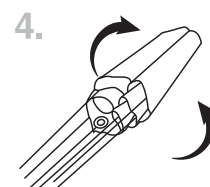
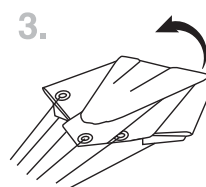
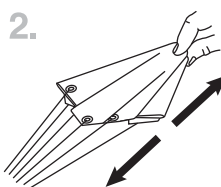
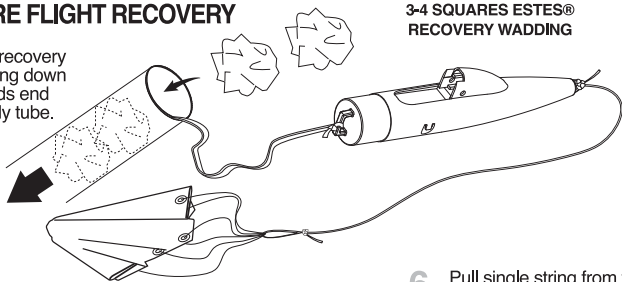

5. Wrap shroud lines loosely and insert parachute into body tube

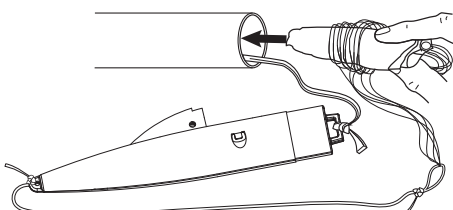

6. Pull single string from top tight down groove on bottom of nose cone and hold with thumb while inserting into body tube

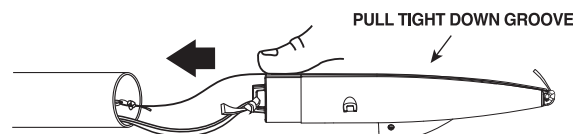

- 7.

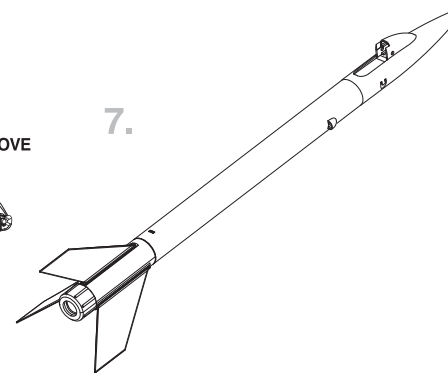

NOTE:

Recovery wadding and parachute must slide easily into body tube. If too tight, redo.

APPLY DECALS



PREPARE ENGINE

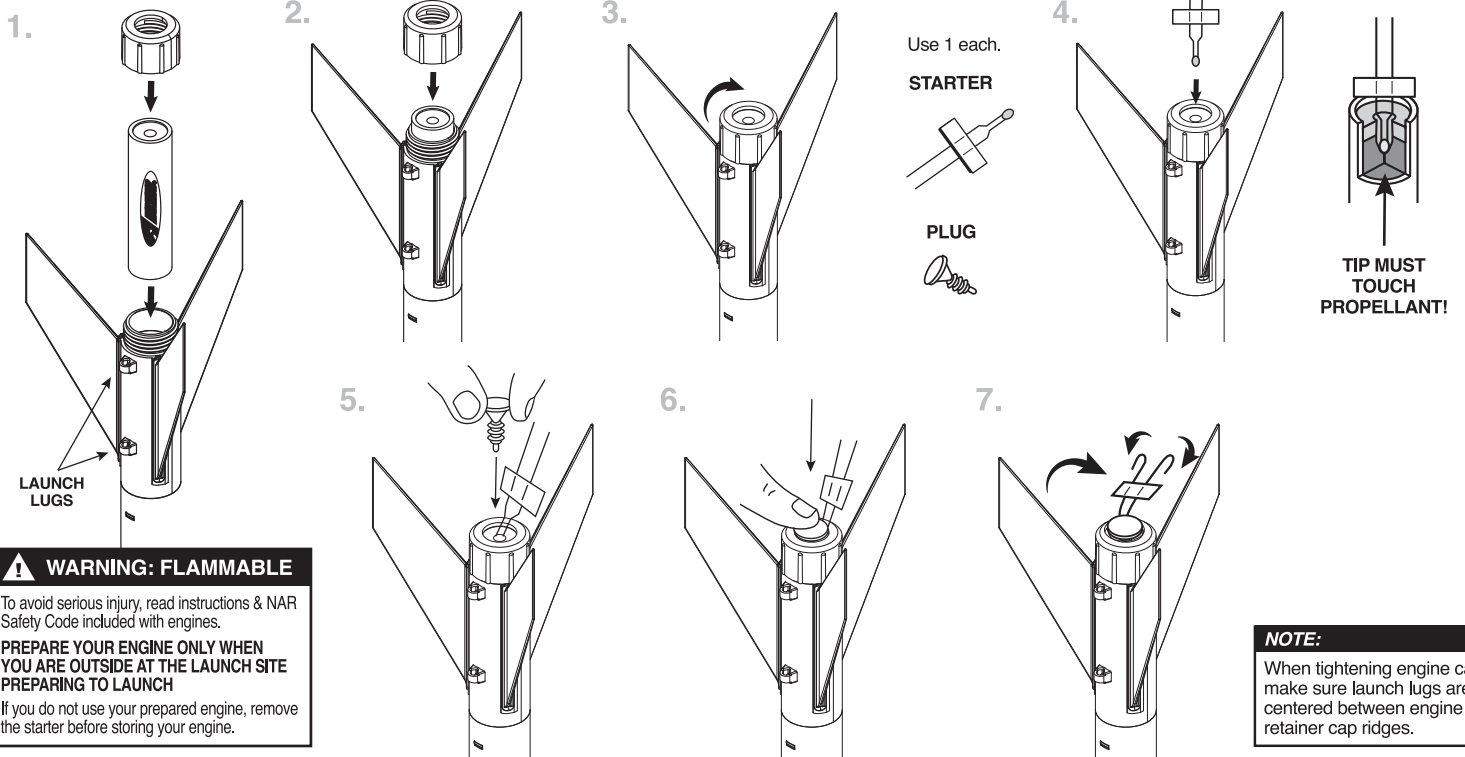

PREPARE CAMERA

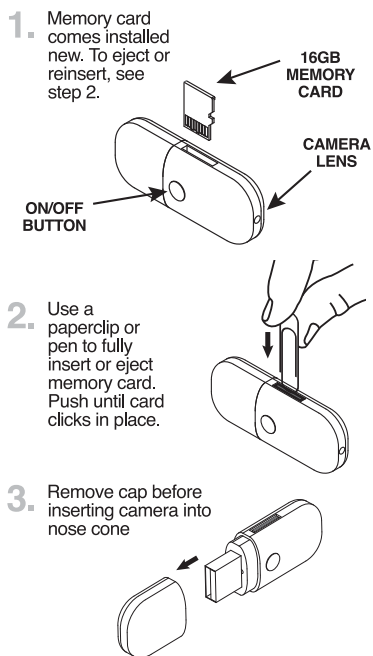

INSERT CAMERA

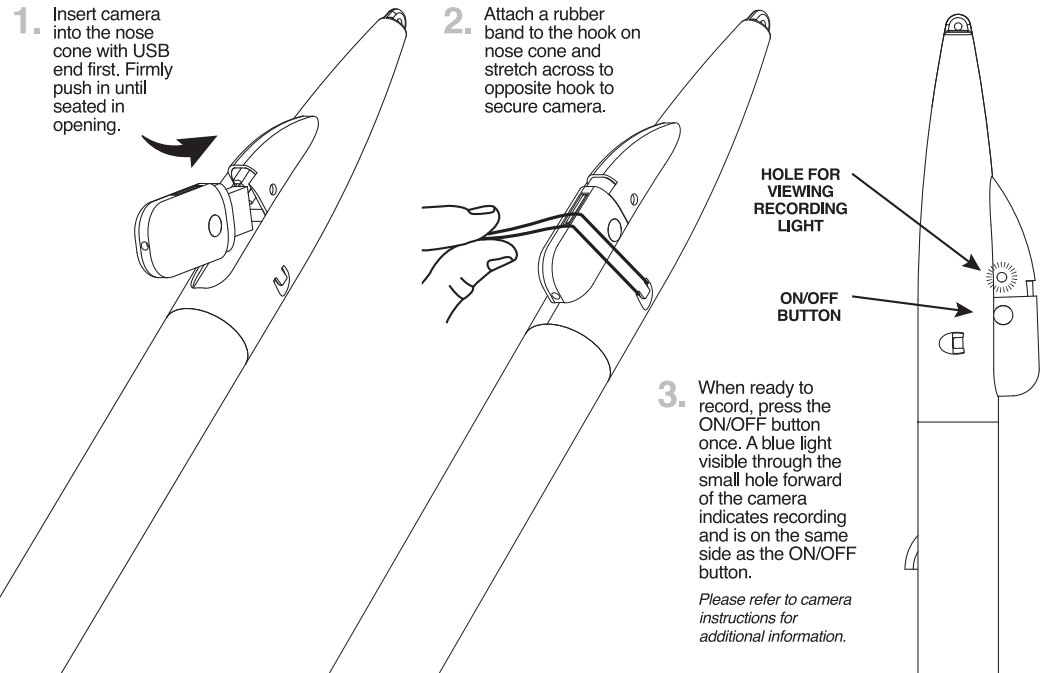

COUNTDOWN AND LAUNCH

NOTE:

Key always out until final countdown!

ESTES® LAUNCH SUPPLIES INCLUDED

(Starter Set Contains)

- Porta-Pad II® Launch Pad
- Electron Beam® Launch Controller
- Recovery Wadding
- Starters (with engines)
- Plugs (with engines)
- B6-4, C6-5 Engines (one each)

NOTE:

Be sure and turn camera on before launching. Press the ON/OFF button once to begin recording.

Please refer to camera instructions for additional information.

NOTE:

Fully extend your launch controller wire before launching.

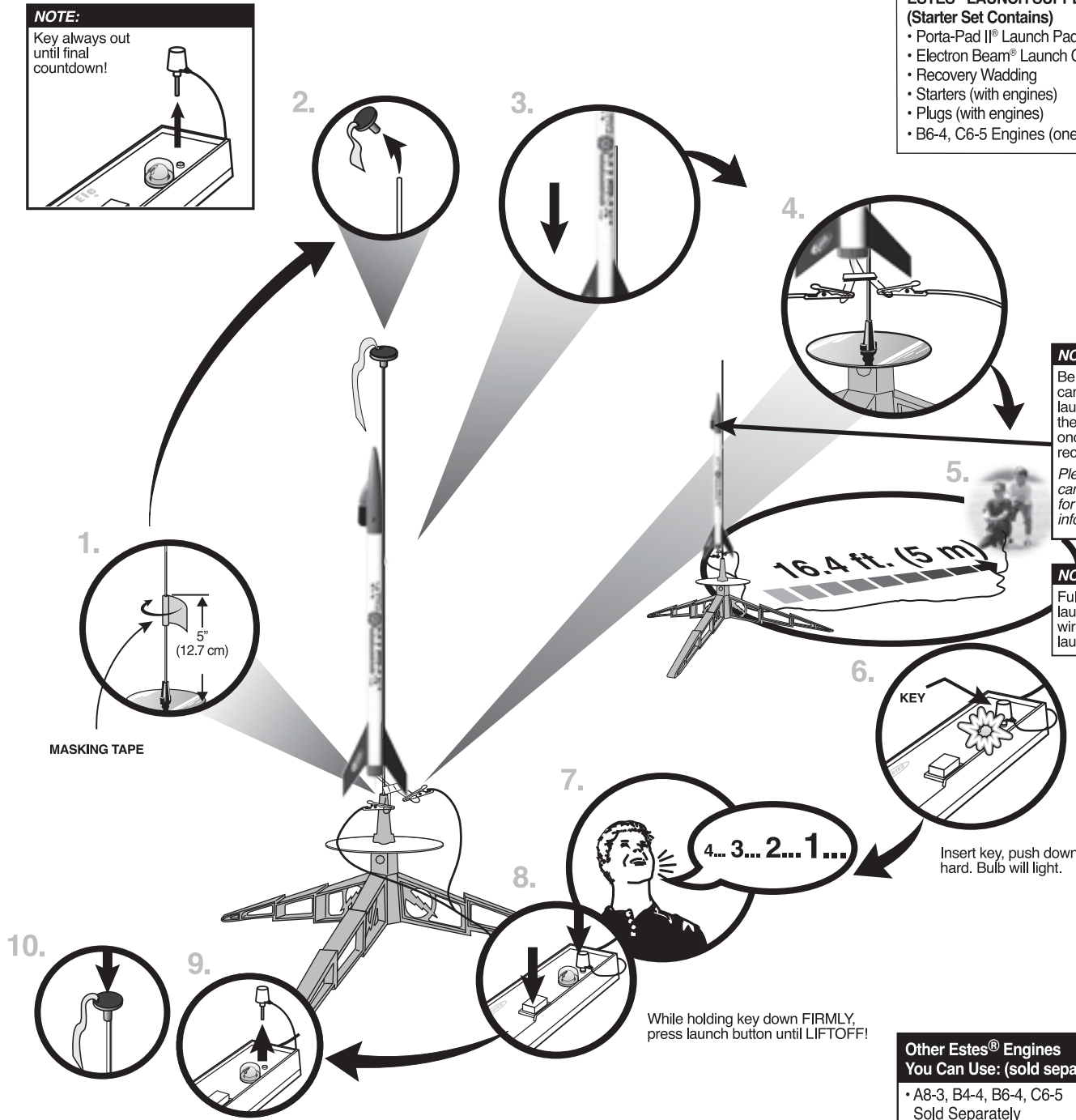

MASKING TAPE

16.4 ft. (5 m)

4... 3... 2... 1...

While holding key down FIRMLY, press launch button until LIFTOFF!

Other Estes® Engines You Can Use: (sold separately)

- A8-3, B4-4, B6-4, C6-5 Sold Separately

NOTE:

Estimated weight: 1.5 oz. (42.6 g)

PRECAUTIONS



NAR SAFETY CODE



NO DRY GRASS OR WEEDS

PRE-LAUNCH CHECK: For safety, never launch a damaged rocket. Check the rocket's body, nose cone and fins. Also, check the engine mount, recovery system and launch lug(s). Repair any damage before launching the rocket.

FLYING YOUR ROCKET: Choose a large field (500 ft. [152 m] square) free of dry weeds and brown grass. The larger the launch area, the better your chance of recovering your rocket. Football fields and playgrounds are great. Launch only with little or no wind and good visibility. Always follow the National Association of Rocketry (NAR) SAFETY CODE (enclosed).

MISFIRES: TAKE THE KEY OUT OF THE CONTROLLER. WAIT ONE MINUTE BEFORE GOING NEAR THE ROCKET. Disconnect the micro-clips and remove the engine. Take the plug and starter out of the engine. A burned starter means the starter tip was not touching engine propellant. Install a new starter; be sure the tip is touching propellant inside the engine. Push the plug in place. Repeat steps under Countdown and Launch.

