



EstesRockets.com

SPACE 2 INSPIRE™

9428

AGES
10+

Skill Level

BEGINNER



MODEL ROCKET INSTRUCTIONS

KEEP FOR FUTURE REFERENCE

IMPORTANT: Please record date found on decal and keep for future reference. _____

READ ALL INSTRUCTIONS. Make sure you have all parts and supplies. Test fit all parts before applying glue. Refer to your glue manufacturer's dry times during build.

SUPPLIES



PLASTIC CEMENT



FINE SANDPAPER

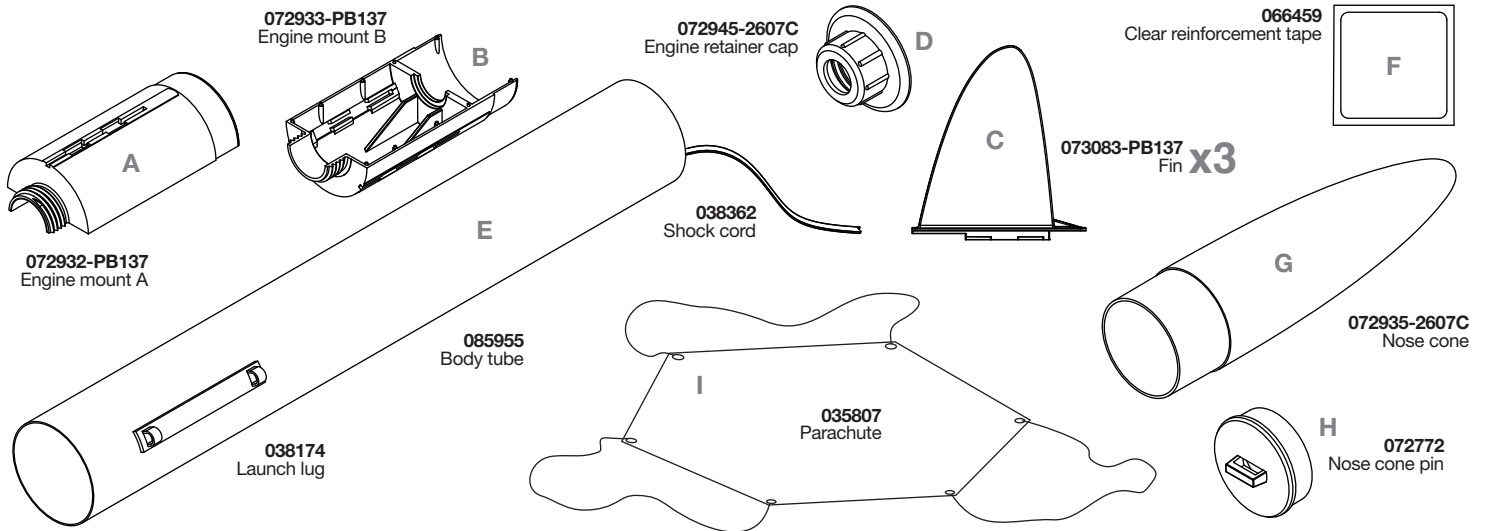

ASSEMBLE FIN CAN UNIT

1. Apply plastic cement to the edges of engine mount B.

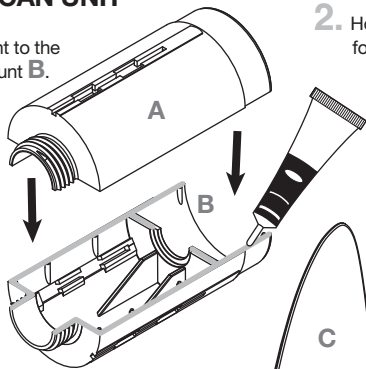

2. Hold A and B together for 20 seconds.

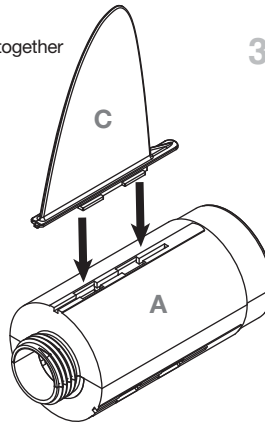

3. Insert fin C into A/B fin can unit and slide forward to lock into place.

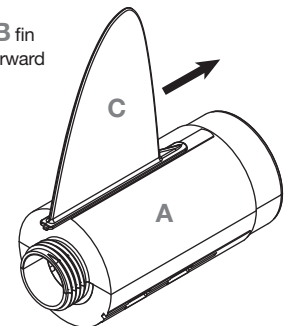

CAUTION:
For safe handling of plastic cement, see manufacturer's warnings and follow instructions for use.

4. Repeat steps 2 and 3 for all three fins.

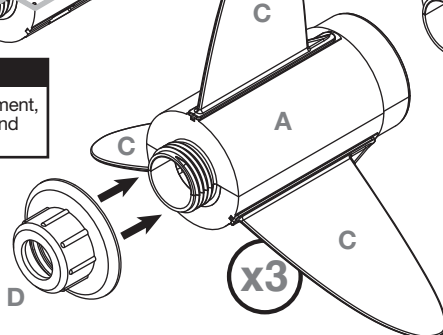

5. Screw engine retainer cap D onto A/B fin can unit.

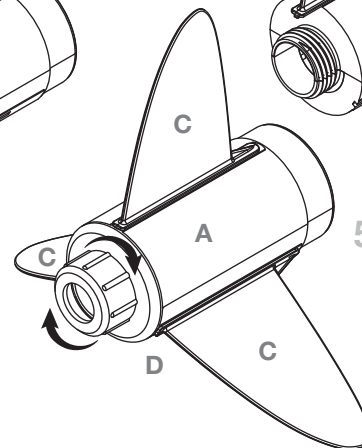

ASSEMBLE FIN CAN UNIT AND BODY TUBE

1. Apply plastic cement to the inside end of body tube **E**.

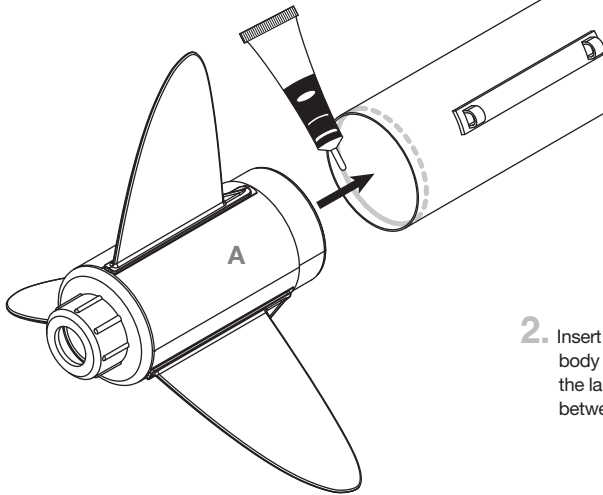

2. Insert fin can unit into body tube **E** ensuring the launch lug is centered between two fins.

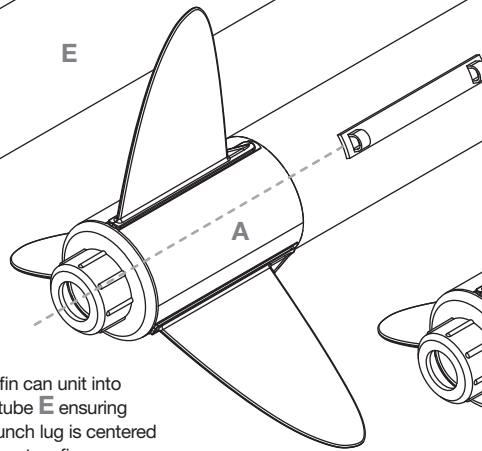

3. Remove the backing from clear reinforcement tape **F** and place it over the launch lug.

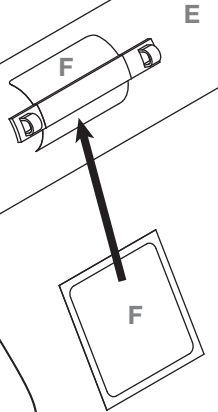

LET DRY

ASSEMBLE NOSE CONE

1. Apply plastic cement to the inside of nose cone **G**.

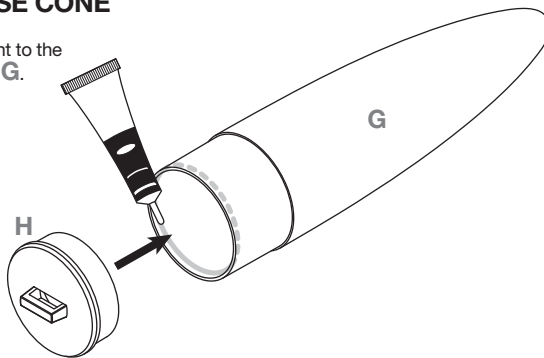

2. Insert nose cone pin **H** into nose cone **G**.

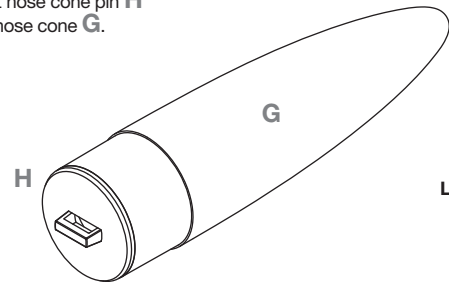

LET DRY

ASSEMBLE RECOVERY SYSTEM

1.

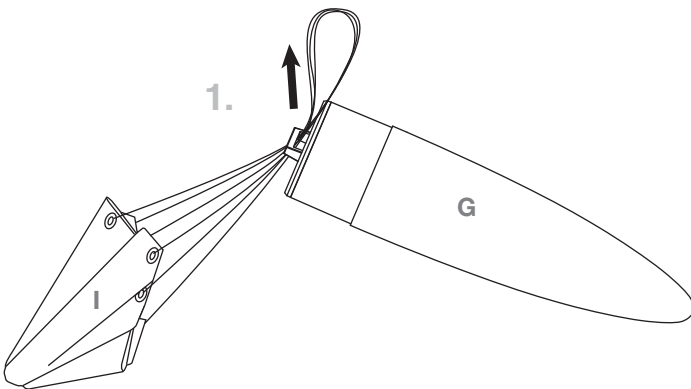

2.

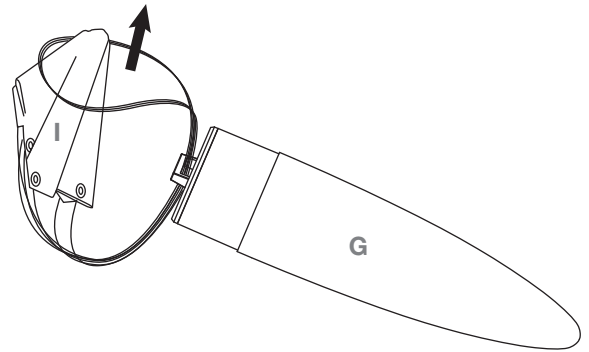

3.

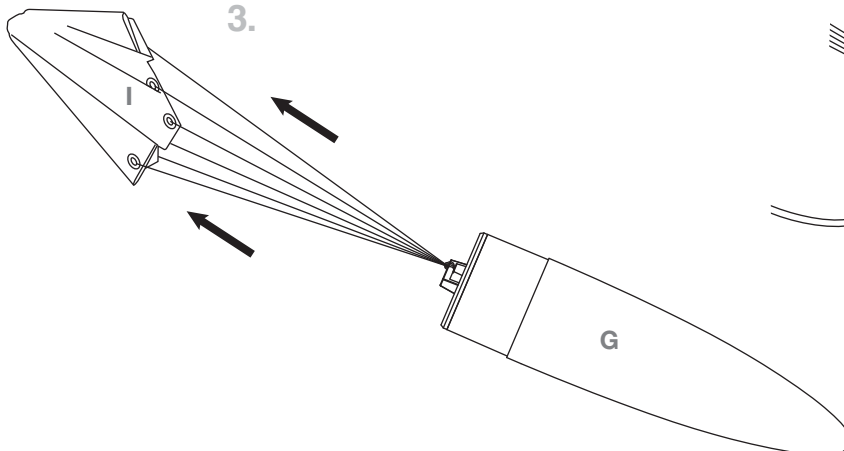

4. Tie shock cord to nose cone pin **H**.

DOUBLE KNOT

PREPARE RECOVERY SYSTEM

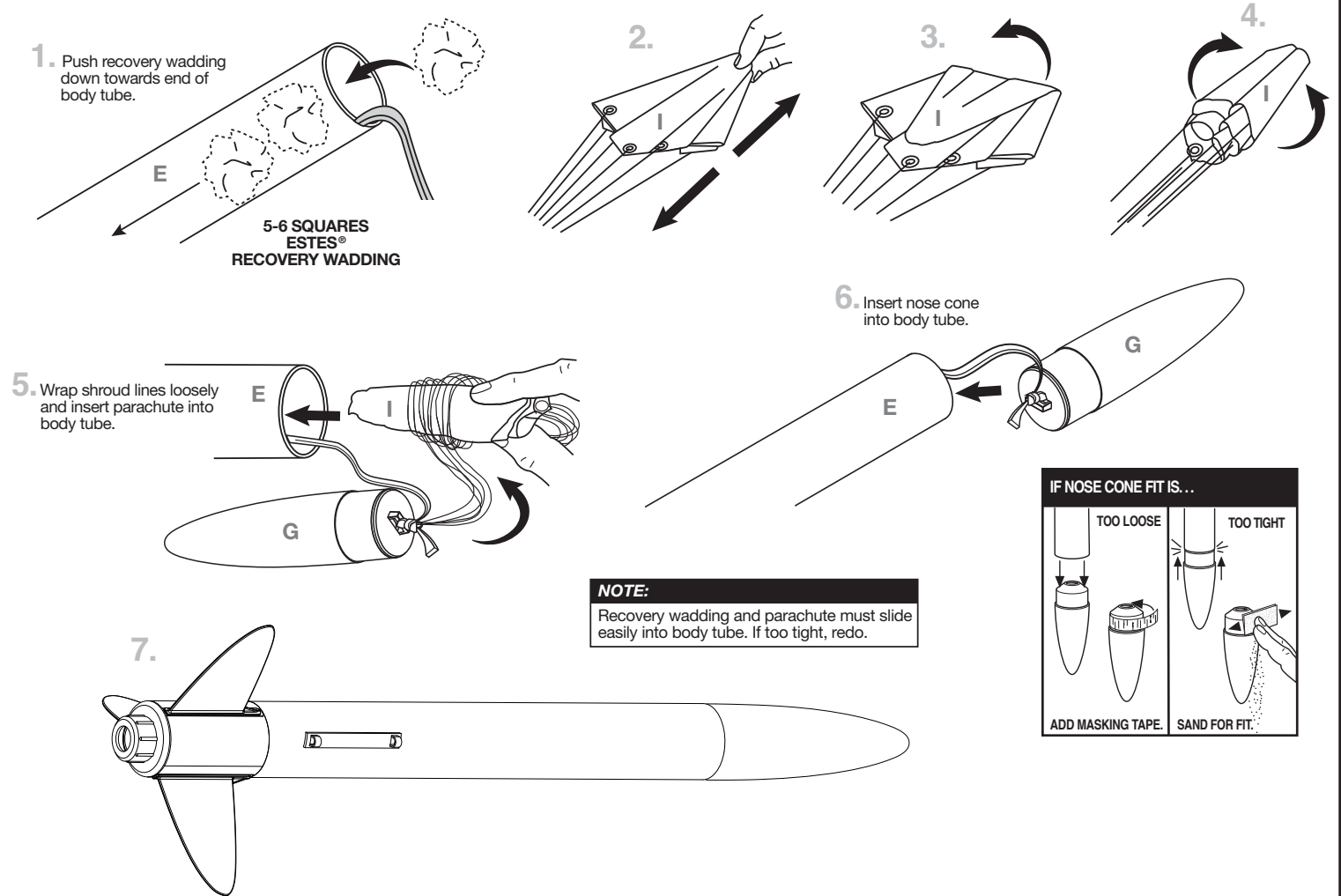

PREPARE ENGINE

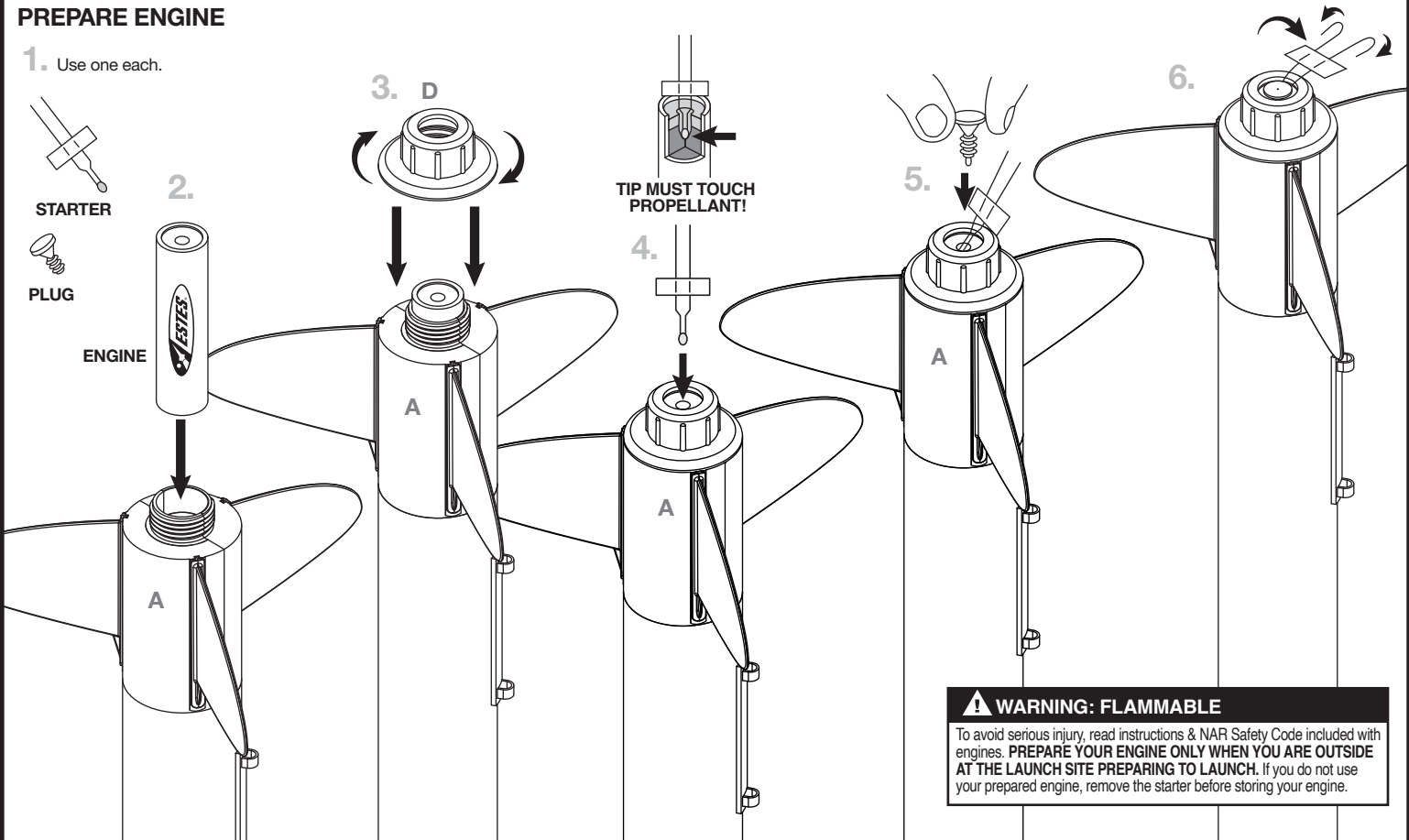

COUNTDOWN AND LAUNCH

NOTE:

Always keep the key **OUT** until final countdown.

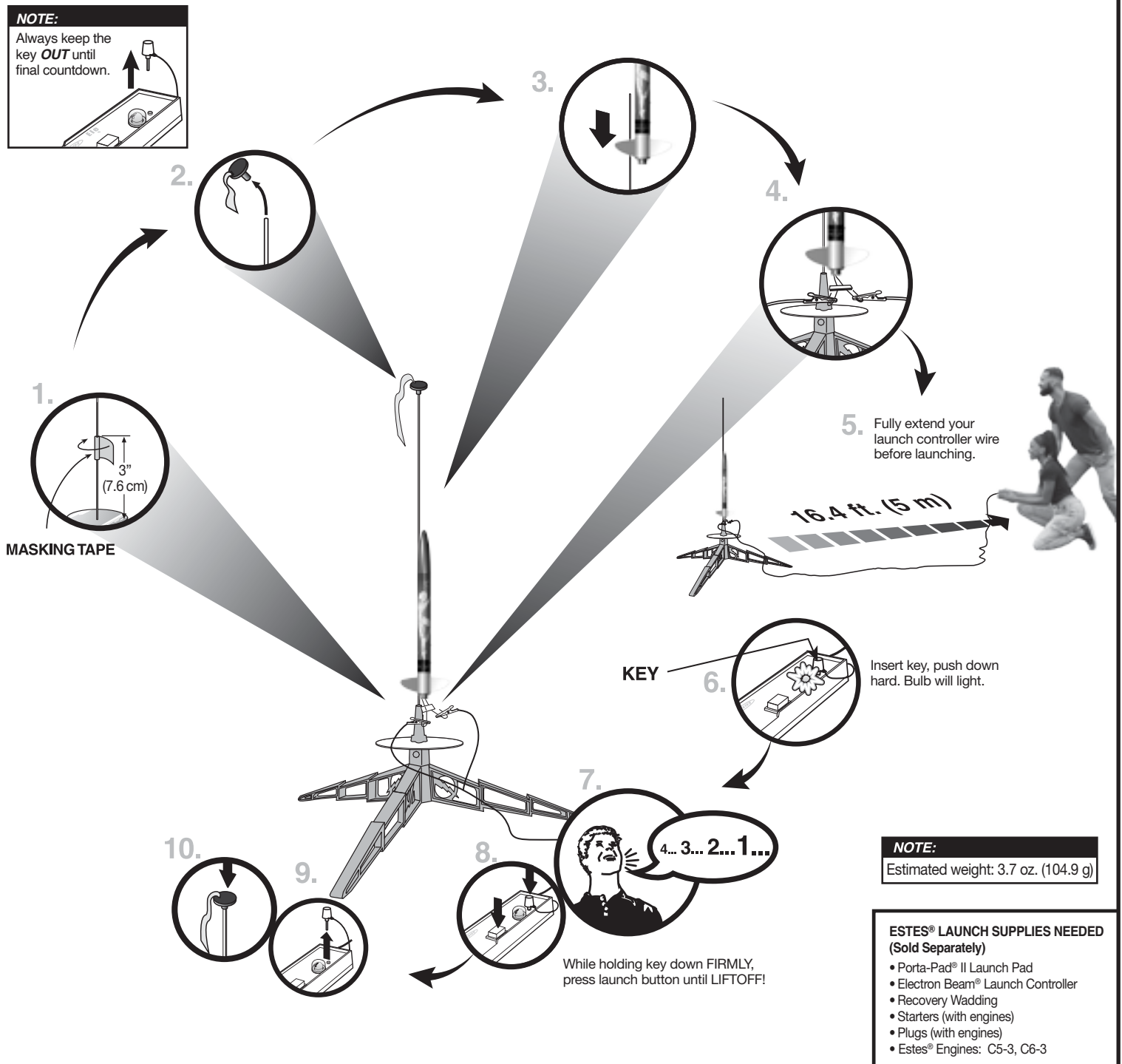

PRECAUTIONS



NAR SAFETY CODE



NO DRY GRASS OR WEEDS

PRE-LAUNCH CHECK For safety, never launch a damaged rocket. Check the rocket's body, nose cone and fins. Also, check the engine mount, recovery system and launch lug(s). Repair any damage before launching the rocket.

FLYING YOUR ROCKET Choose a large field (1000 ft. [305 m] square) free of dry weeds and brown grass. The larger the launch area, the better your chance of recovering your rocket. Launch only with little or no wind and good visibility. Always follow the National Association of Rocketry (NAR) SAFETY CODE (enclosed).

MISFIRES TAKE THE KEY OUT OF THE CONTROLLER. WAIT ONE MINUTE BEFORE GOING NEAR THE ROCKET. Disconnect the micro-clips and remove the engine. Take the plug and starter out of the engine. A burned starter means the starter tip was not touching engine propellant. Install a new starter; be sure the tip is touching propellant inside the engine. Push the plug in place. Repeat steps under Countdown and Launch.