



EstesRockets.com

PRO SERIES II

9725

1:18 ATHENA H

AGES 18+



Skill Level
EXPERT

MODEL ROCKET INSTRUCTIONS

KEEP FOR FUTURE REFERENCE

IMPORTANT: Please record date found on decal and keep for future reference. _____

READ ALL INSTRUCTIONS. Make sure you have all parts and supplies. Test fit all parts before applying glue. Refer to your glue manufacturer's dry times during build.

SUPPLIES



SCISSORS



HOBBY KNIFE



SOFT LEAD PENCIL



RULER



FINE SANDPAPER



YELLOW GLUE

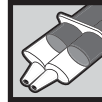

EPOXY



CA GLUE



MASKING TAPE



SPRAY ADHESIVE



WHITE PRIMER



PAINT (Listed on Pg. 5)



CLEAR COAT (OPTIONAL)

032416 x4 Fin Half **F**

032417 x4 Fin Half **G**

085705 Clay x2 **M**

072412 Engine Retainer Set **K**

032418-A Spin Motor Half x2 **R**

032418-B Spin Motor Half x2 **S**

032418-E Spin Ring x2 **O**

032418-C Spin Ring Top **P**

032418-D Spin Ring Bottom **Q**

032419 Scale Launch Lug **J**

090050B-9725 Centering Ring **C**

090051-9725 Laser Cut Raceway **I**

032851 Vacuum Form Wrap **T**

031940 Engine Mount **A**

090050A-9725 Centering Ring w/ Notch **B**

031971 Body Tube **N**

031972 Body Tube **E**

073241 Nose Cone/ Transition **L**

038358 Aramid Cord **D**

038374 Elastic shock cord **V**

038181 Launch Lug x2 **H**

090001-9725 Decals **U**

035814 Nylon Parachute **U**

Paint masks / marking guides

Roll pattern paint masks

ASSEMBLE ENGINE MOUNT & INSTALL ARAMID CORD

1. Apply yellow glue to the end of engine mount **A**.

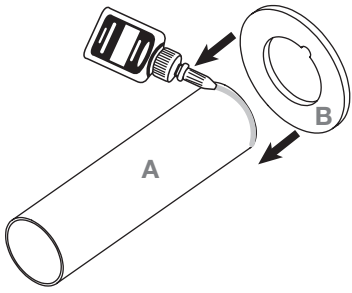

2. Slide centering ring **B** over the end of engine mount tube **A**. Make sure the centering ring is flush with the end of the engine mount tube.

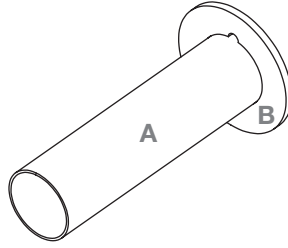

3. Apply yellow glue 0.5 in. from opposite end of engine mount tube **A**.

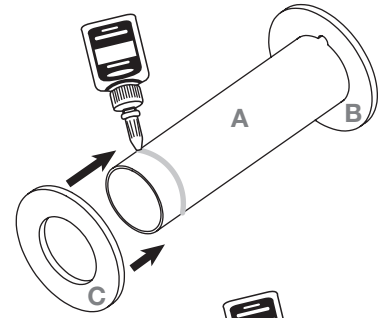

4. Apply glue fillets on the inside joint of centering ring **B** and on both sides of centering ring **C**.

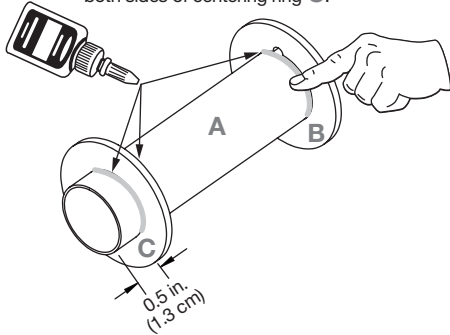

5. Thread Aramid cord **D** through notch in centering ring **B**.

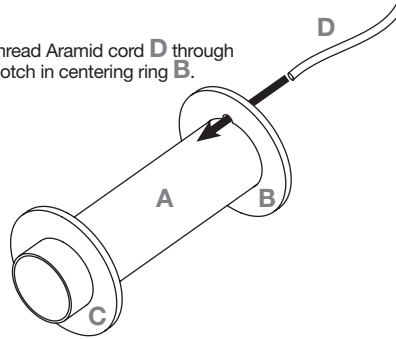

6. Loop Aramid cord **D** around engine mount tube **A** and tie a knot. Apply a drop of glue to the knot.

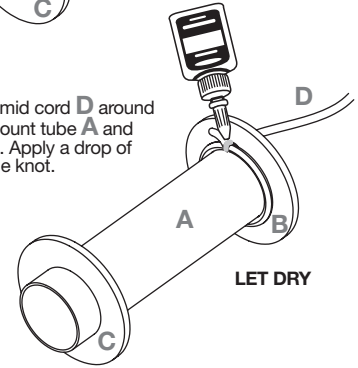

TUBE MARKING

1. Cut out fin marking guide from marking guide template sheet.

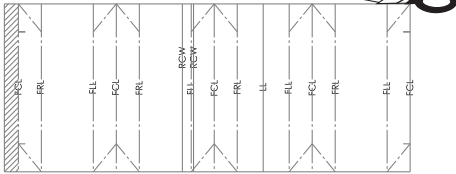

2. Wrap fin marking guide around body tube **E** and secure with a piece of tape. This will be the base of the rocket.

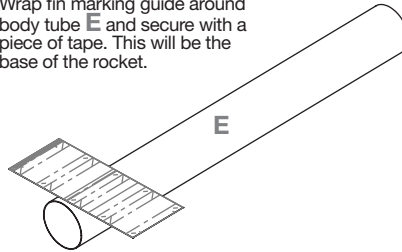

3. Using a pencil, make marks on body tube **E** based on all 15 lines from the fin marking guide.

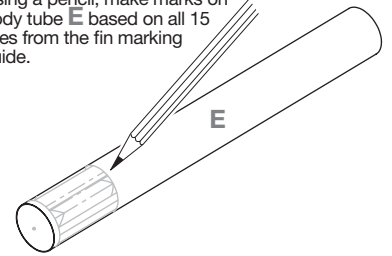

4. Remove the fin marking guide and use a door frame to extend all of the lines on body tube **E**.

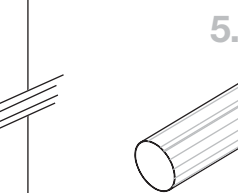
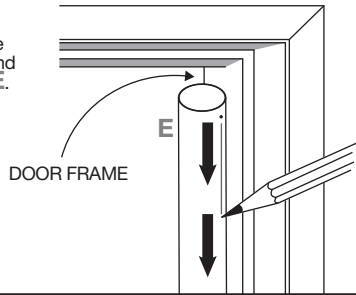

NOTE:
Letter each line same as the template for your reference in later steps.

INSTALL ENGINE MOUNT

1. Apply yellow glue inside the base of body tube **E**. Thread Aramid cord **D** through the body tube and insert the engine mount assembly into the base of body tube **E**.

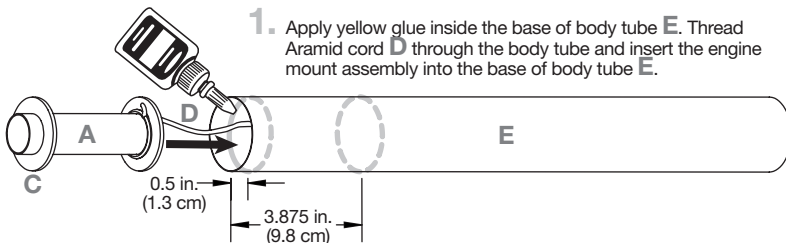

2.

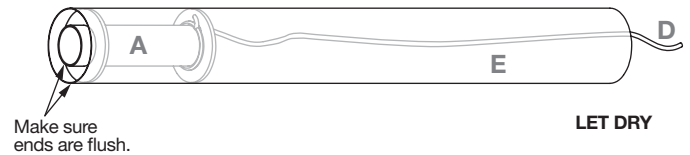

FIN ASSEMBLY

1. Apply CA glue to all bonding surfaces of fin half **G**. Align fin halves **F** and **G** and press together.

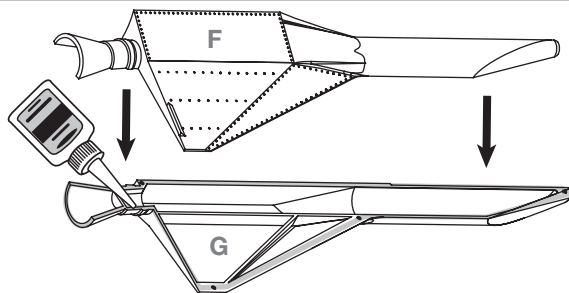

2. Repeat for all four fins.

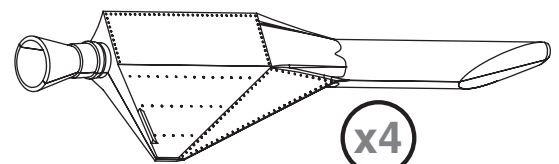

CAUTION:
For safe handling of CA glue, see manufacturer's warnings and follow instructions for use.

LET DRY

ATTACH FINS

1. Apply CA glue to entire mounting surface of F/G fin assembly.

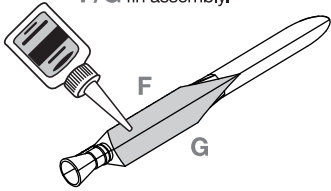

2. Attach F/G fin assembly to base of body tube E, aligning fin with the fin lines marked on the body tube. Be sure the fin base is flush with the end of body tube E.

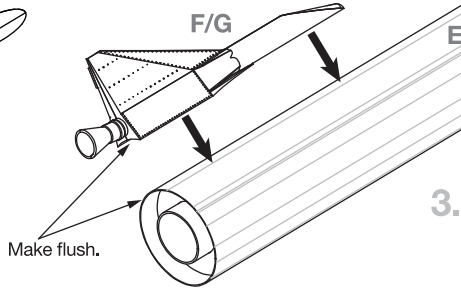

3. Repeat for all four fins. Use fin alignment guide on marking guide template to ensure the fins are at 90° angles.

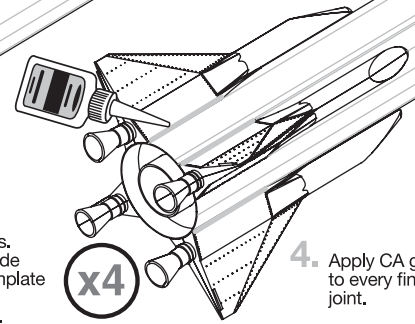

4. Apply CA glue fillets to every fin connection joint.

LET DRY

ATTACH LAUNCH LUGS

1. Using yellow glue, attach launch lugs H to body tube E, aligning them with the launch lug line on the body tube. Attach one launch lug 0.5 in. from the base of the body tube and the other 6 in. higher.

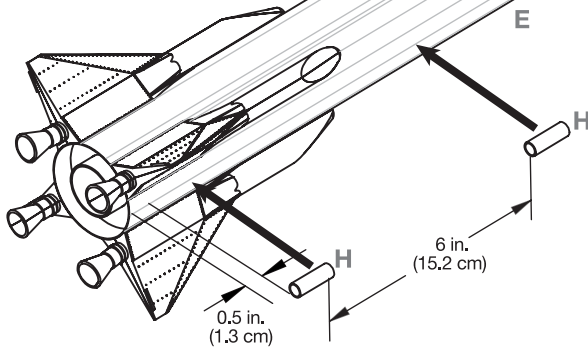

2.

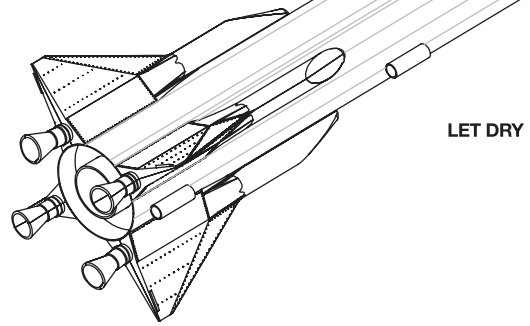

LET DRY

SHAPING AND ATTACHING RACEWAY

1. Sand both sides of raceway I and carefully cut out strips with a sharp hobby knife.

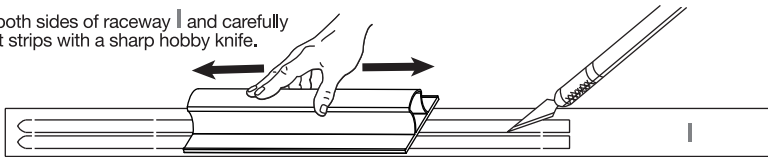

2. Using sandpaper, bevel the top corners of raceway I to round them over. Then bevel the rounded ends of the raceway as shown on the image to the right. Only one end of each raceway piece needs to be beveled.

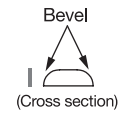

3. Using yellow glue, attach the upper raceway I to the top of body tube E. Align it between the raceway line marked on the body tube and make sure the rounded end is flush with the top of the body tube. Then attach the lower raceway, aligning the end with the upper raceway and with the rounded end pointing toward the base of the body tube.

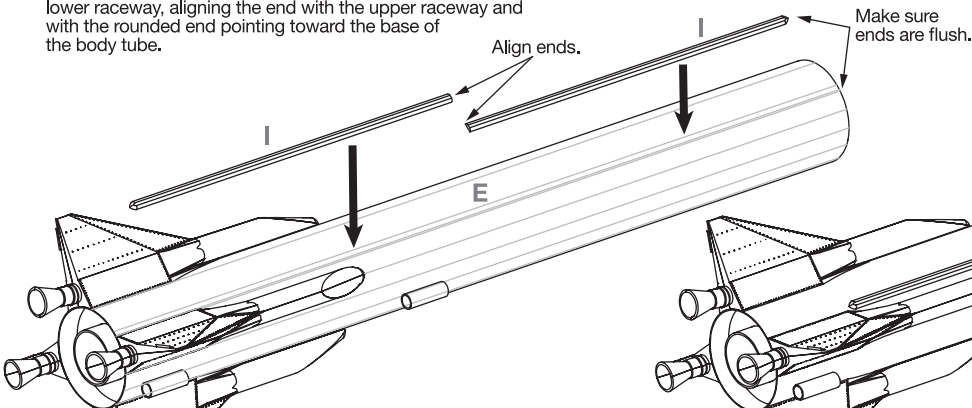

4.

LET DRY

ATTACH SCALE LAUNCH LUG

1. Using CA glue, attach scale launch lug J on the opposite side of the body tube from the launch lugs H 2.125 in. from the body tube base.

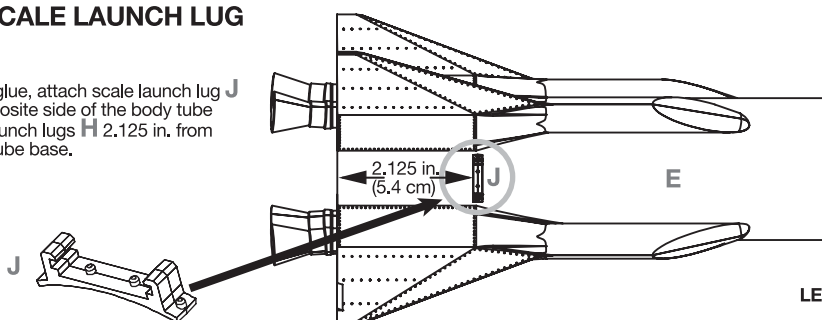

LET DRY

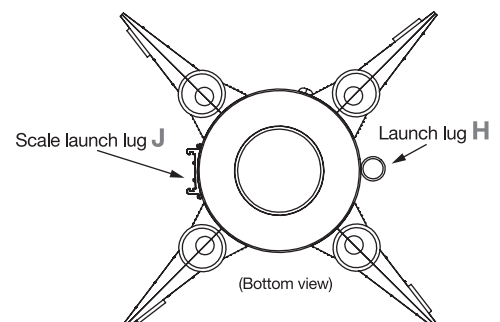

(Bottom view)

INSTALL ENGINE RETAINER

1. Roughen the inside of engine retainer **K** with a piece of sandpaper.

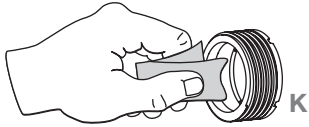

2. Apply epoxy to the inside of engine retainer **K**.

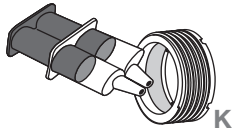

3. Place engine retainer **K** on engine mount tube **A** with notches facing towards the rocket.

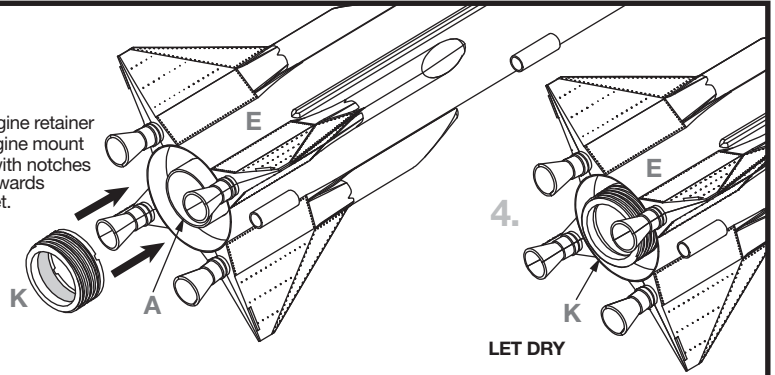

ASSEMBLE FORWARD SECTION

1. Using a sharp hobby knife, cut nose cone/transition **L** to separate the nose cone from the transition.

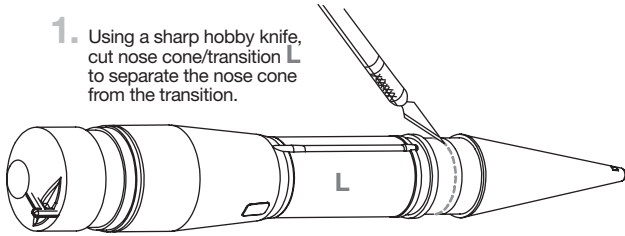

2. After **L** pieces have been separated, roll one piece of clay **M** with your hands to soften and push inside the nose cone.

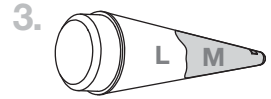
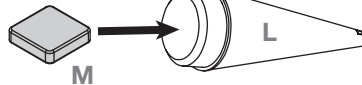

4. Apply CA glue to the inside of one end of body tube **N** and insert nose cone and transition **L** into the body tube.

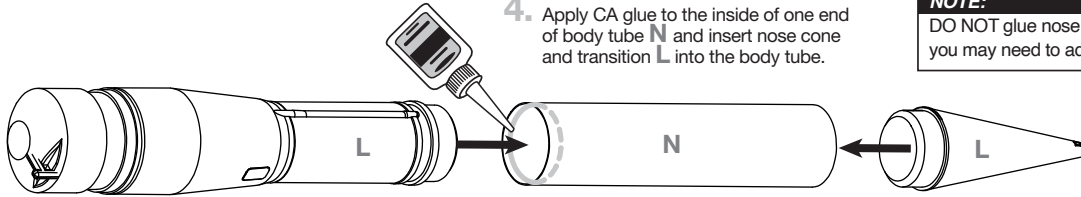

NOTE:
DO NOT glue nose cone in as you may need to add more clay.

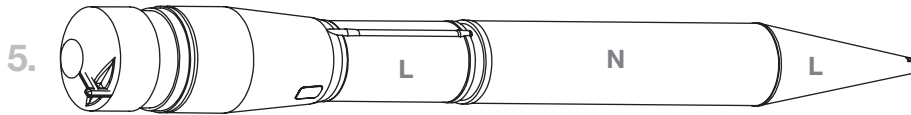

LET DRY

SPIN RING ASSEMBLY

1. Apply CA glue to both joining faces of spin rings **O**. Press together.

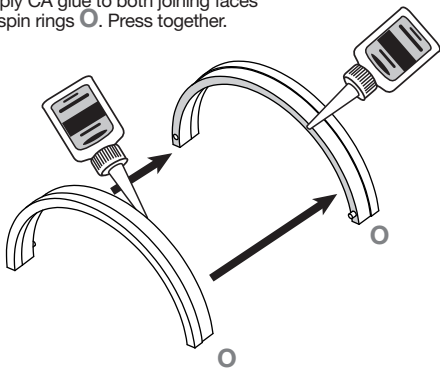

2.

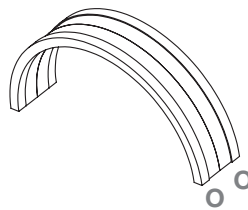

3. Apply CA glue to both joining faces of spin rings **P** and **Q**. Press together.

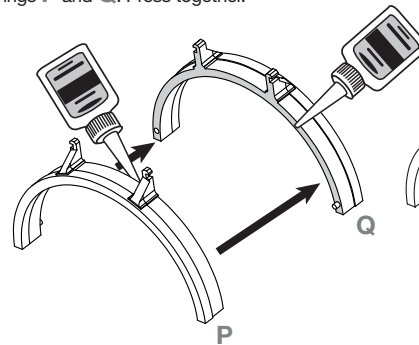

4.

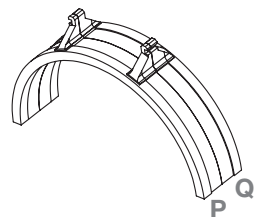

LET DRY

SPIN MOTOR ASSEMBLY

1. Apply CA glue to both joining faces of spin motor halves **R** and **S**. Press together.

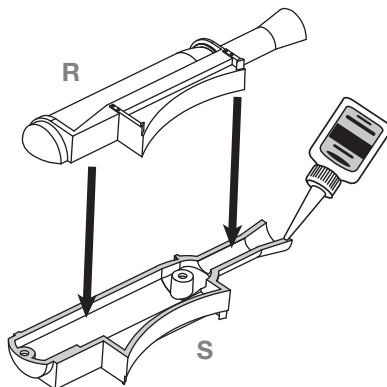

2. Repeat for both spin motors.

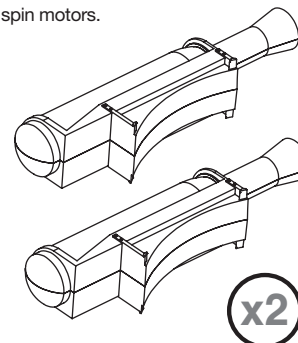

x2

LET DRY

ATTACH SPIN RINGS

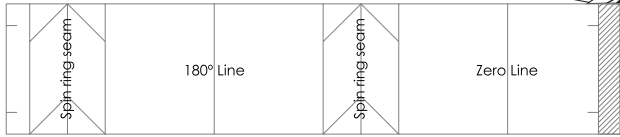

1. Cut out spin motor marking guide from marking guide template sheet.

2. Wrap guide around the shoulder of the forward section. Align the overlap section with the mold seam on transition L. Secure in place with tape.

3. Mark all lines from guide onto the shoulder. Be sure to mark the "zero line" all the way up the transition as this will be necessary for aligning the vacuum form wrap. Remove guide and set aside. Be sure to keep it as you will need it in the painting steps.

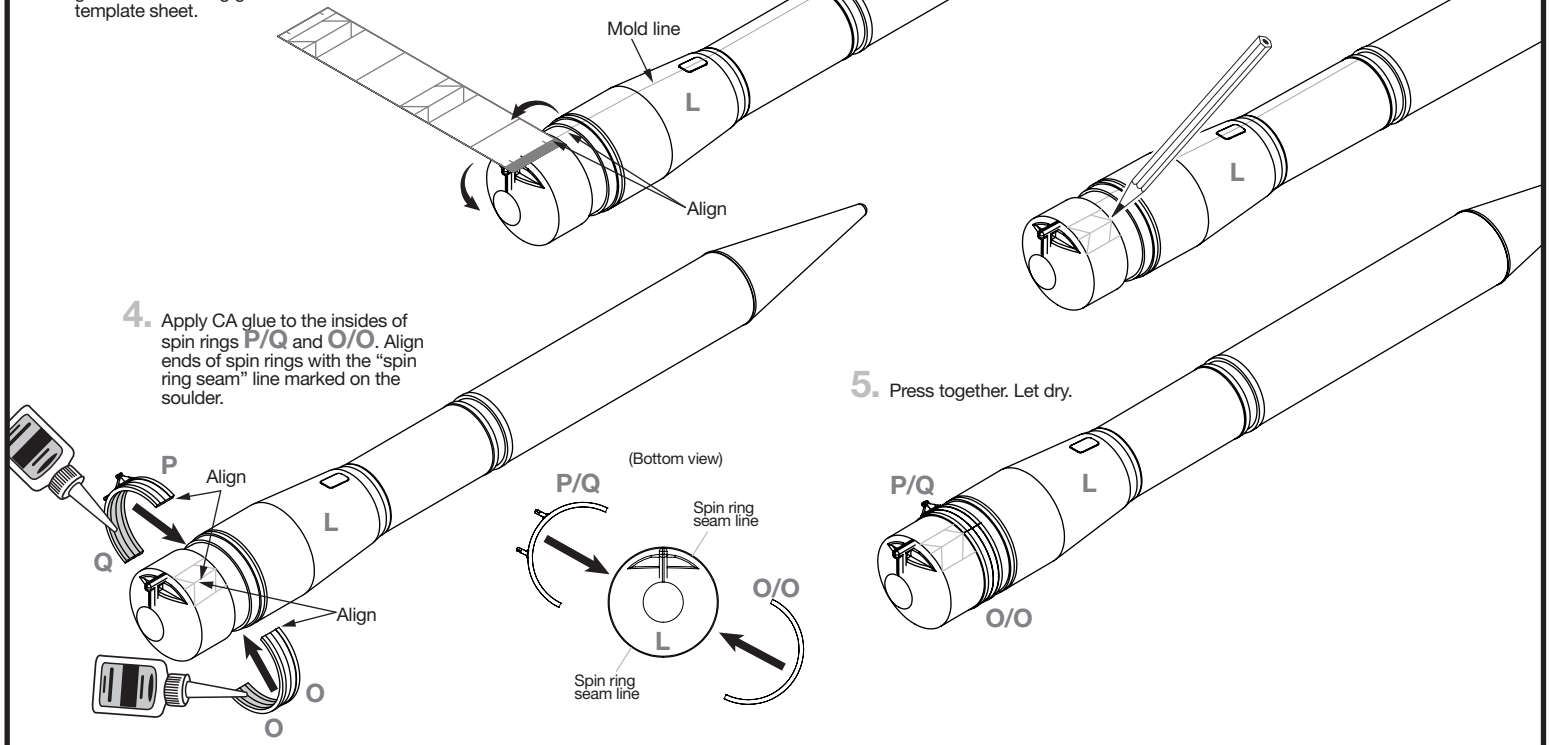

VACUUM FORM WRAP INSTALLATION

1. Trim the edges of vacuum form wrap T. Spray the back with spray adhesive. Use multiple light coats of spray adhesive.

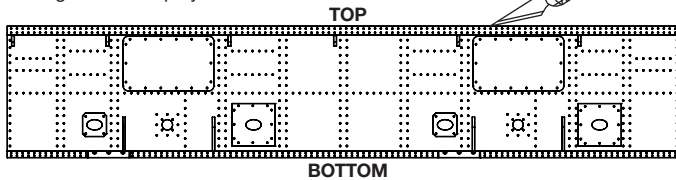

CAUTION:
For safe handling of spray adhesive, see manufacturer's warnings and follow instructions for use.

2. Align one edge of vacuum form wrap T with the "zero line" and wrap around the base of the transition.

3. Apply CA glue to the seam and edges of vacuum form wrap T.

LET DRY

PAINT INSTRUCTIONS

PAINT COLORS

Flat White Paint
Flat Black Paint
Daylight Red Paint
Rust Colored Paint
Flat Gray Paint
Flat Tan Paint
Sliver Paint

1. Prime the rocket and paint it flat white. Let dry.

2. Reuse the spin motor marking guide to mark the 180° line up the length of the forward section.

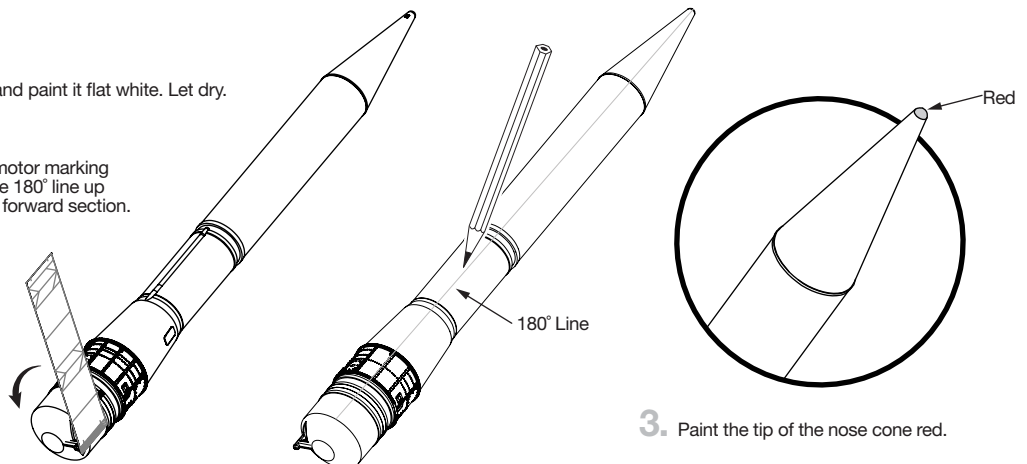

CAUTION:
For safe handling of spray paints, see manufacturer's warnings and follow instructions for use.

3. Paint the tip of the nose cone red.

PAINT INSTRUCTIONS (CONTINUED)

4. Cut out the nose cone paint mask from marking guide template sheet and tape together into cone.

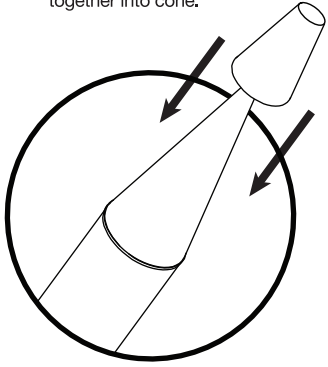

5. Place mask over nose cone and mark around the circumference of the nose cone above and below the mask.

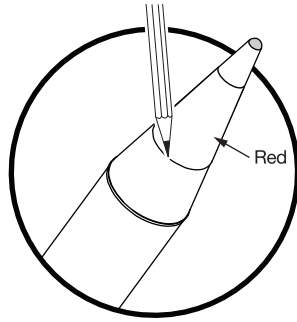

6. Cut out upper BT paint mask from the roll pattern paint mask template page and align the overlap with the 180° line. Wrap around the forward section and secure with tape. Mark area exposed in template to be masked with tape and painted black.

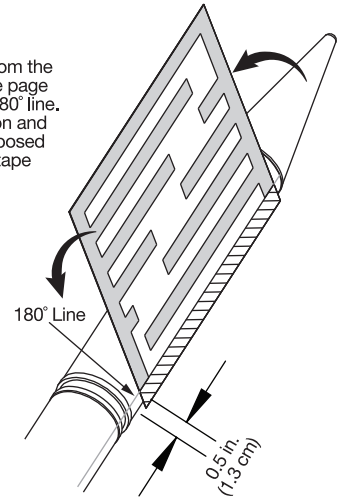

7. Cut out upper transition paint mask from marking guide template sheet and align as shown. Wrap around the upper transition and secure with tape. Mark the lines above and below the template to be masked and painted red.

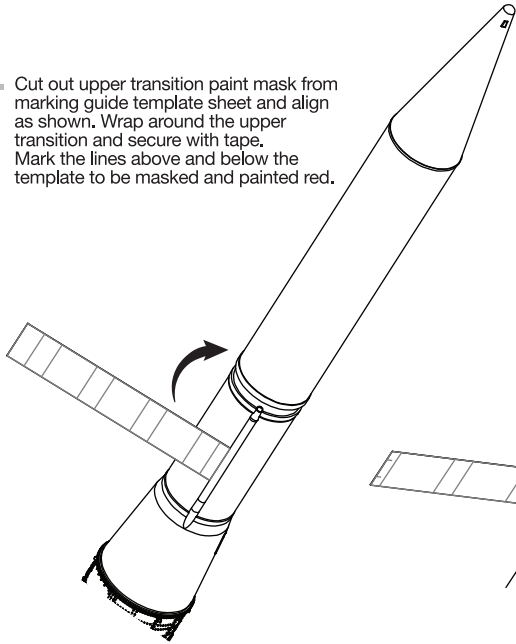

8. Cut out lower transition paint mask from marking guide template sheet and align the overlap with the 180° line. Wrap around the lower transition and secure with tape. Mark the lines above and below the template to be masked and painted red.

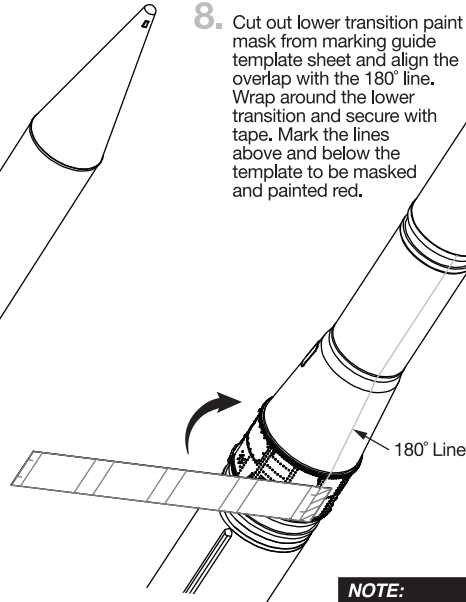

9. Cut out lower BT-70 paint mask from roll pattern paint mask template page and align the edge with the raceway and under the spin ring. Mark area exposed in template to be masked with tape and painted black.

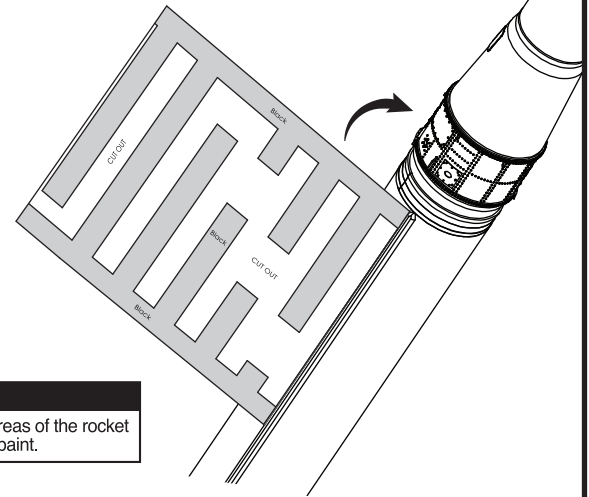

NOTE:
Be sure to mask off all areas of the rocket before applying colored paint.

10. Paint the side of the "nose" of the upper fin with rust colored paint. Paint engine nozzles rust colored as well.

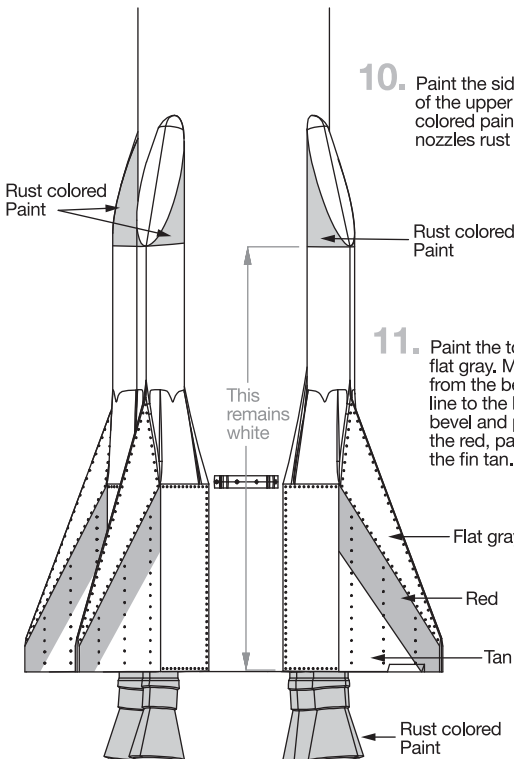

11. Paint the top bevels of the fin with flat gray. Measure 1/2 in. (13 mm) from the bevel and mark a parallel line to the bevel. Paint between bevel and parallel line red. Below the red, paint the bottom part of the fin tan.

12. Paint both spin motors completely with silver.

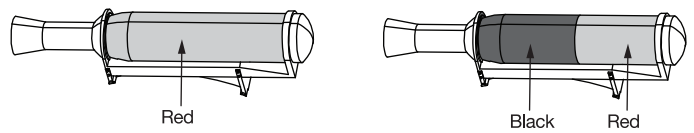

13. Paint one spin motor tank all red.

14. Paint the other spin motor tank half black and half red.

15. Mask the spin ring and paint it silver.

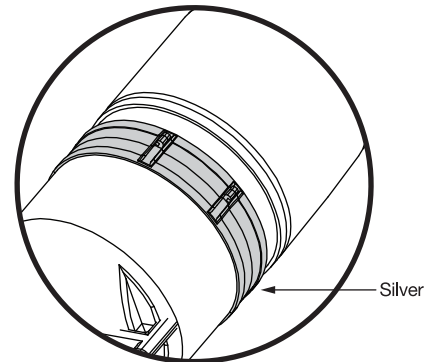

NOTE:
Please refer to box art for painting reference.



LEFT



FRONT (180°)



RIGHT



BACK (0°)

ATTACH SPIN MOTORS

1. Apply CA glue to the contact surface of the spin motor **R/S**. Align with the spin motor alignment lines and attach the spin motor to the spin rings.

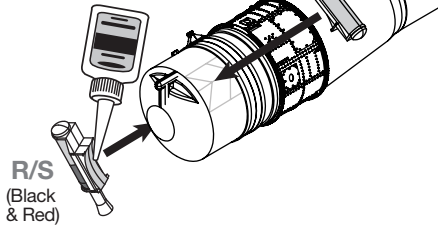

2. Be sure the spin motor (**R/S**) nozzle is facing counter-clockwise when viewed from the bottom. Press together.

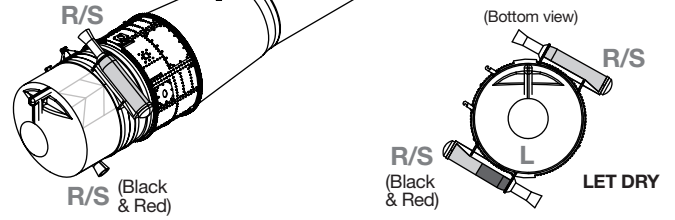

PREPARE RECOVERY SYSTEM

1. Tie a loop at the end of aramid cord **D**.

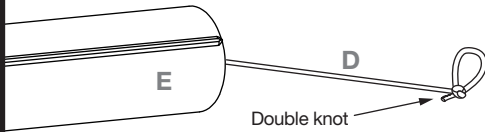

2. Tie one end of shock cord **V** to the loop in aramid cord **D**.

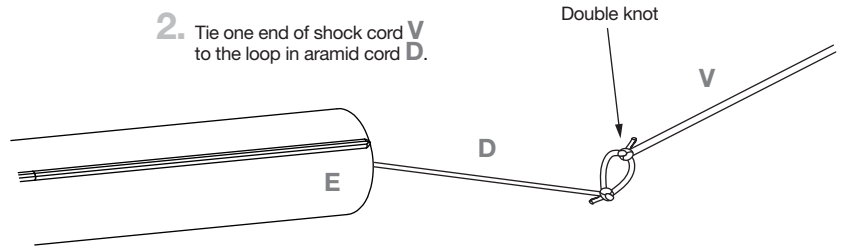

3. Tie a loop approx 3 in. from the end of shock cord **V**. Tie shock cord to transition **L**.

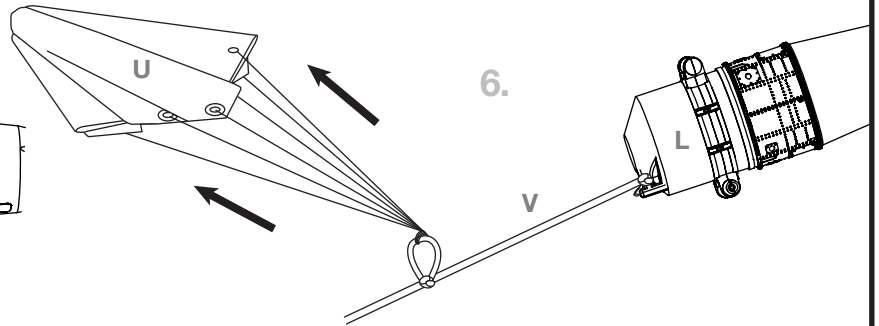
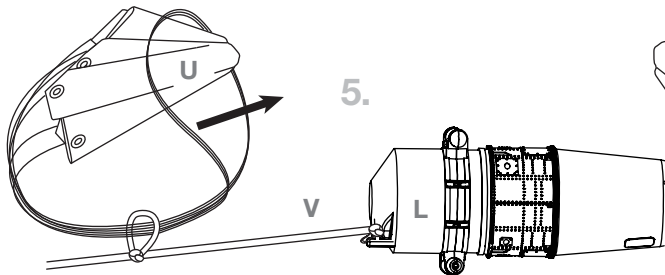
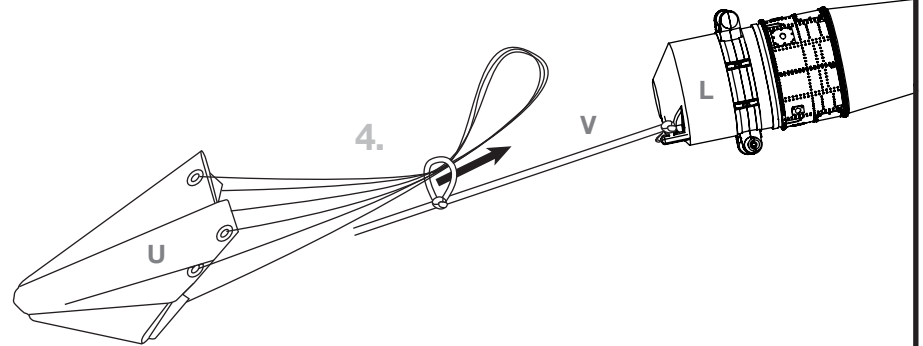
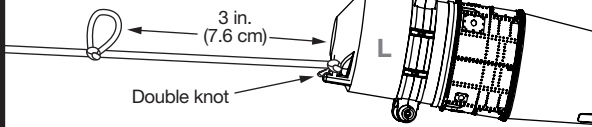

FLIGHT PREPARATION

1. Push recovery wadding down towards end of body tube **E**.

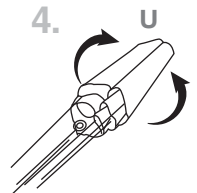
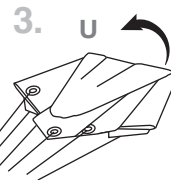
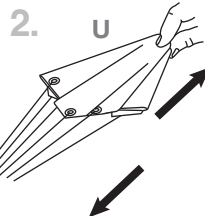
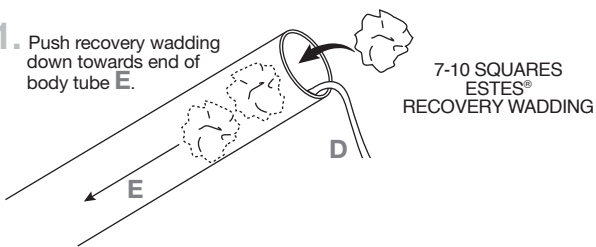

5. Wrap shroud lines loosely and insert parachute into body tube **E**.

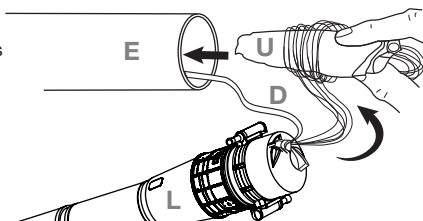

NOTE:

Recovery wadding and parachute must slide easily into body tube. If too tight, redo.

ENGINE PREPARATION

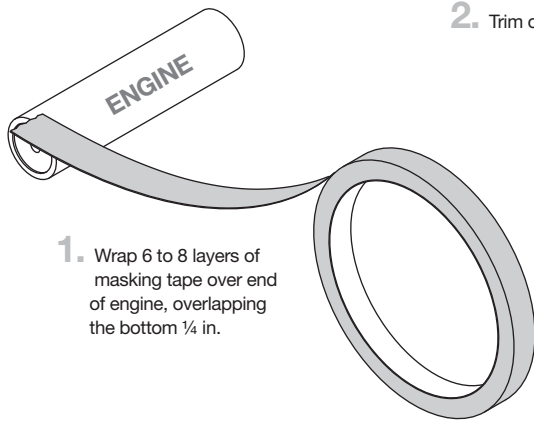

1. Wrap 6 to 8 layers of masking tape over end of engine, overlapping the bottom 1/4 in.

2. Trim off excess tape.

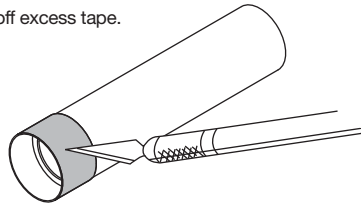

- 3.

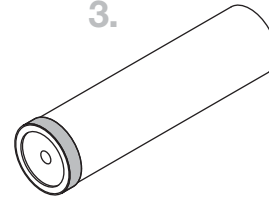

4. Use one each.

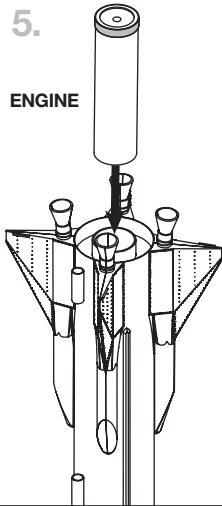
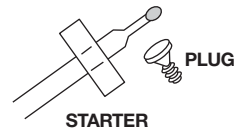

- 5.

ENGINE

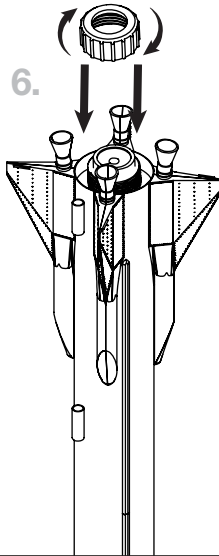

- 6.

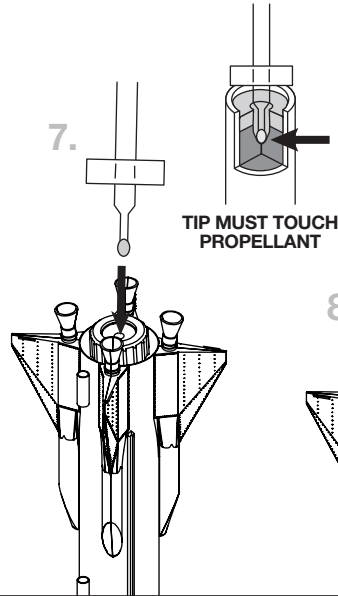

- 7.

TIP MUST TOUCH PROPELLANT

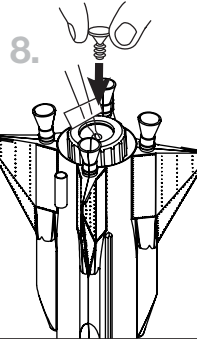

- 8.

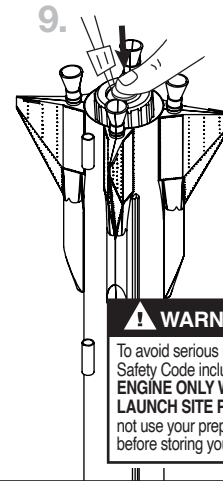

- 9.

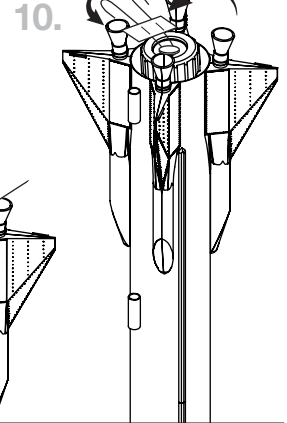

- 10.

⚠ WARNING: FLAMMABLE

To avoid serious injury, read instructions & NAR Safety Code included with engines. **PREPARE YOUR ENGINE ONLY WHEN YOU ARE OUTSIDE AT THE LAUNCH SITE PREPARING TO LAUNCH.** If you do not use your prepared engine, remove the starter before storing your engine.

CHECK CENTER OF GRAVITY

1. After the engine is installed, ensure that the center of gravity is 28 in. (71.1 cm) from the front of the rocket. The center of gravity can be further forward of this point, but cannot be further back from this point. If the center of gravity is further back than 28 in., add more clay to the nose cone to add weight and bring the center of gravity forward.

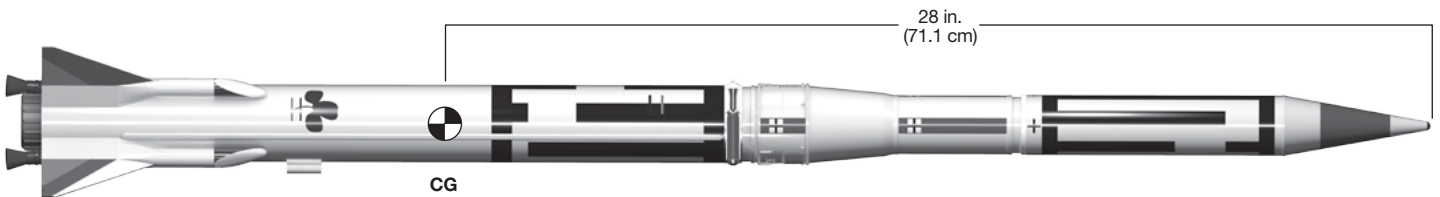

2. Apply CA glue to the inside of body tube N. Insert nose cone L into body tube N.

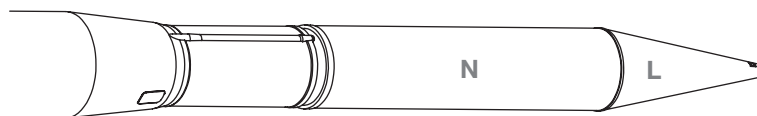
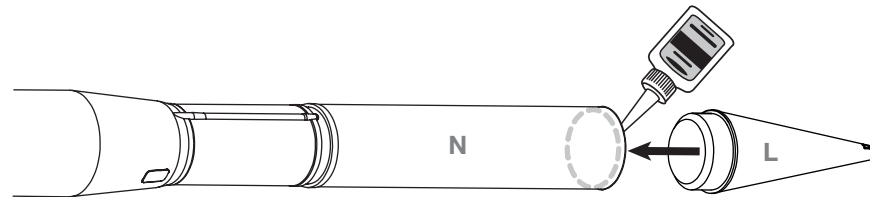

LET DRY

COUNTDOWN AND LAUNCH

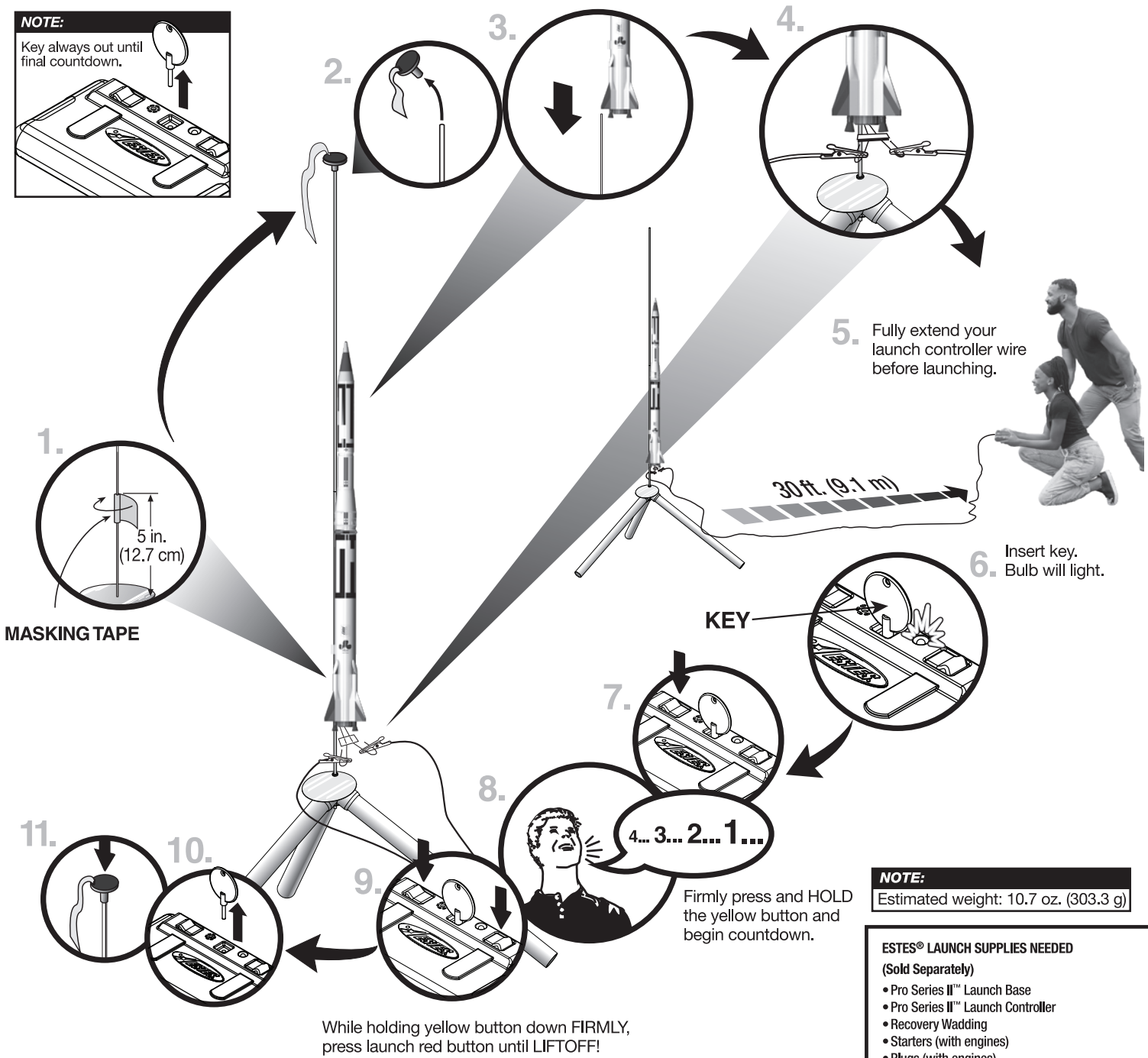
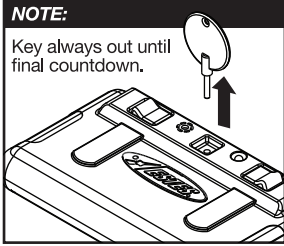

NOTE:
Estimated weight: 10.7 oz. (303.3 g)

- ESTES® LAUNCH SUPPLIES NEEDED**
(Sold Separately)
- Pro Series II™ Launch Base
 - Pro Series II™ Launch Controller
 - Recovery Wadding
 - Starters (with engines)
 - Plugs (with engines)
 - Recommended Estes® Engines: D12-3, E12-4, E16-4, F15-4

PRECAUTIONS



NAR SAFETY CODE



NO DRY GRASS OR WEEDS

PRE-LAUNCH CHECK For safety, never launch a damaged rocket. Check the rocket's body, nose cone and fins. Also, check the engine mount, recovery system and launch lug(s). Repair any damage before launching the rocket.

FLYING YOUR ROCKET Choose a large field (1000 ft. [305 m] square) free of dry weeds and brown grass. The larger the launch area, the better your chance of recovering your rocket. Launch only with little or no wind and good visibility. Always follow the National Association of Rocketry (NAR) SAFETY CODE (enclosed).

MISFIRES TAKE THE KEY OUT OF THE CONTROLLER. WAIT ONE MINUTE BEFORE GOING NEAR THE ROCKET. Disconnect the micro-clips and remove the engine. Take the plug and starter out of the engine. A burned starter means the starter tip was not touching engine propellant. Install a new starter; be sure the tip is touching propellant inside the engine. Push the plug in place. Repeat steps under Countdown and Launch.



Paint Masks / Marking Guides



Upper transition paint mask

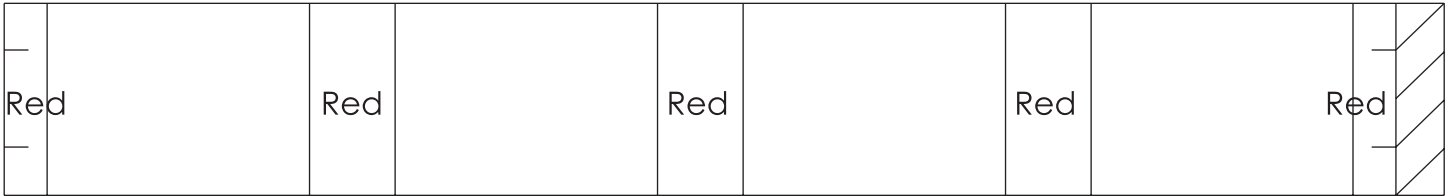

Lower transition paint mask

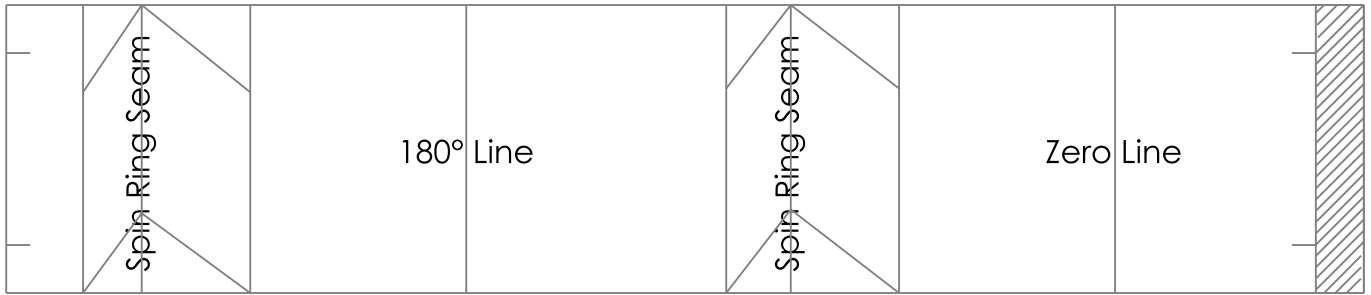

Spin Motor Marking Guide

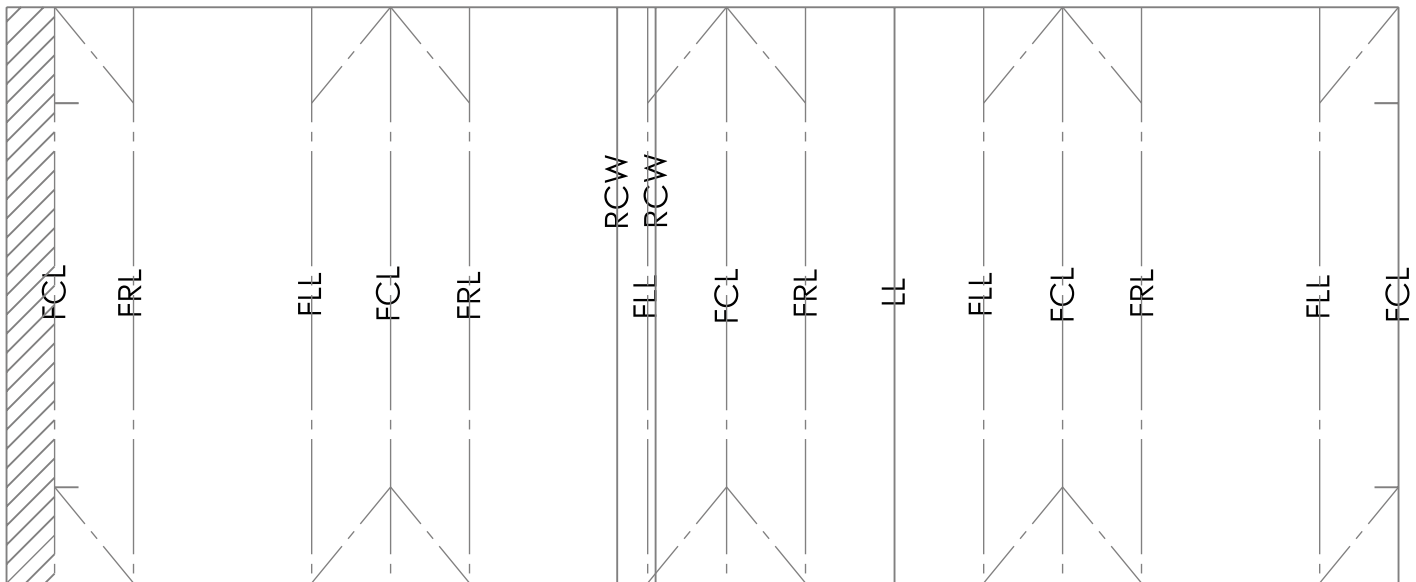

Fin Marking Guide

FLL - Fin Left Line
FCL - Fin Center Line
FRL - Fin Right Line

RCW - Raceway
LL - Launch Lug

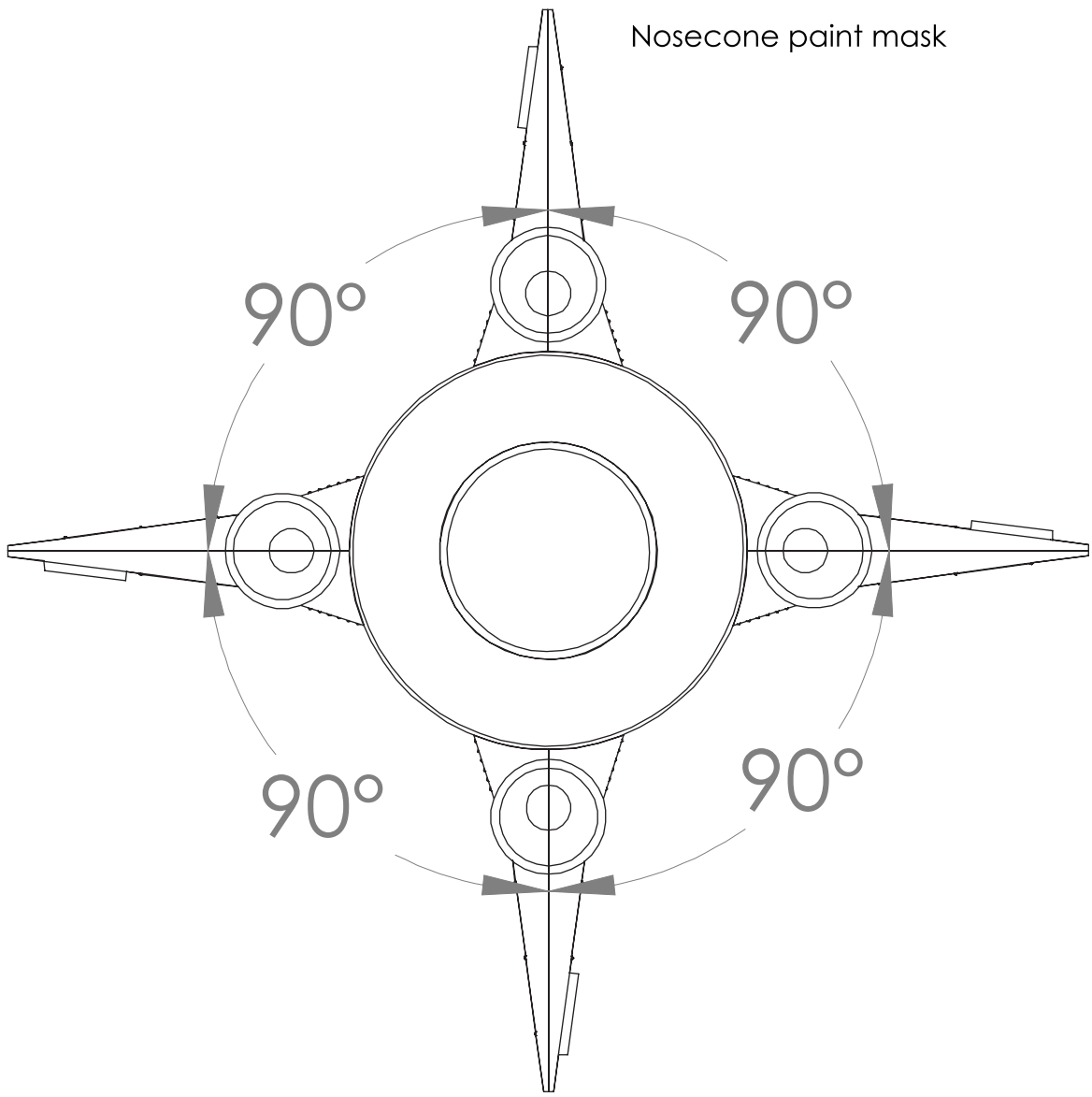
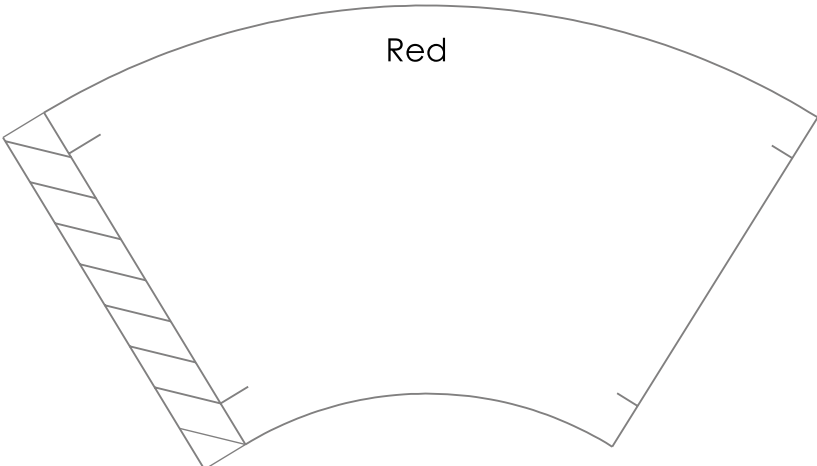

Athena H roll pattern paint masks

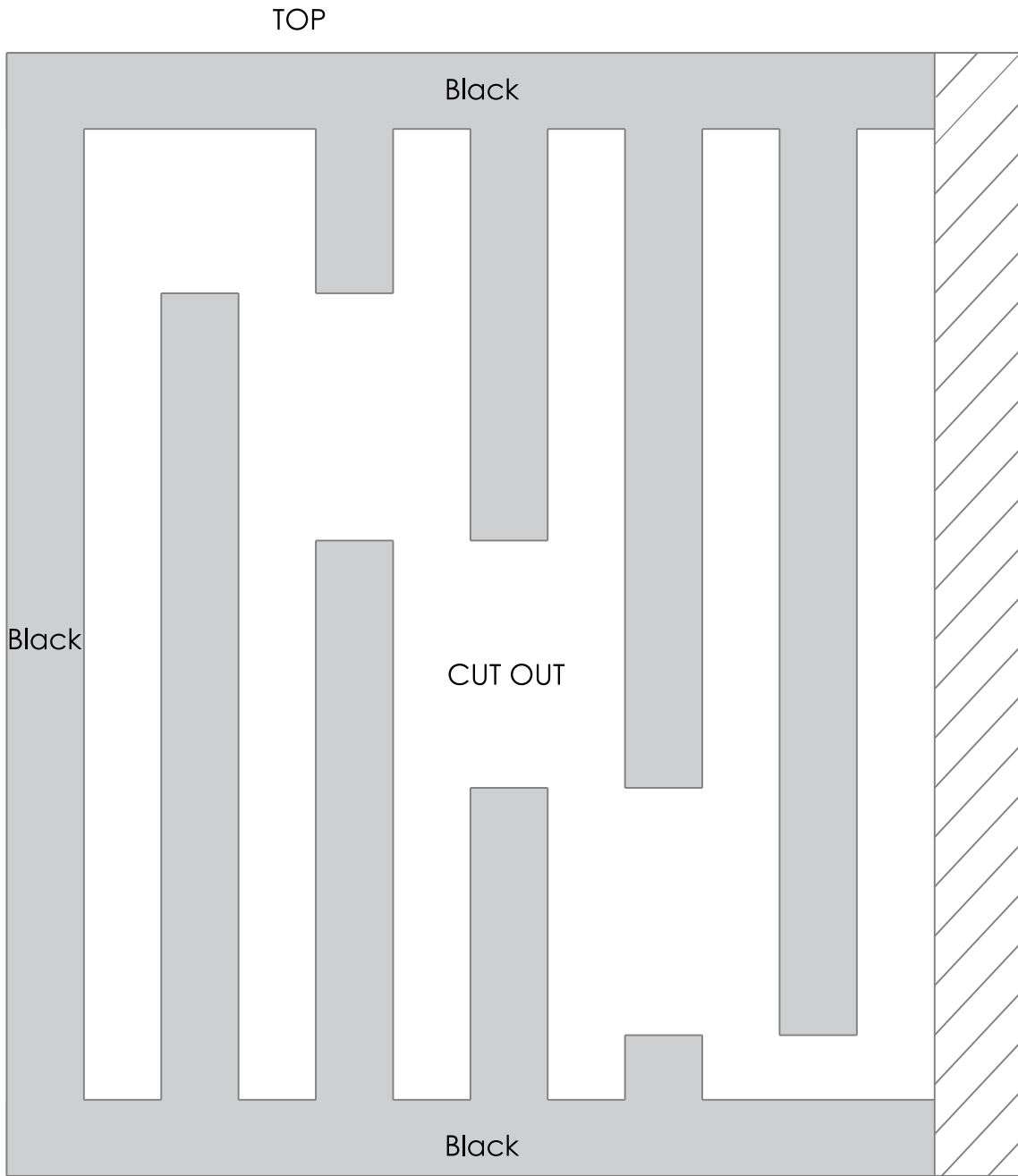

upper BT-Athena paint mask

TOP

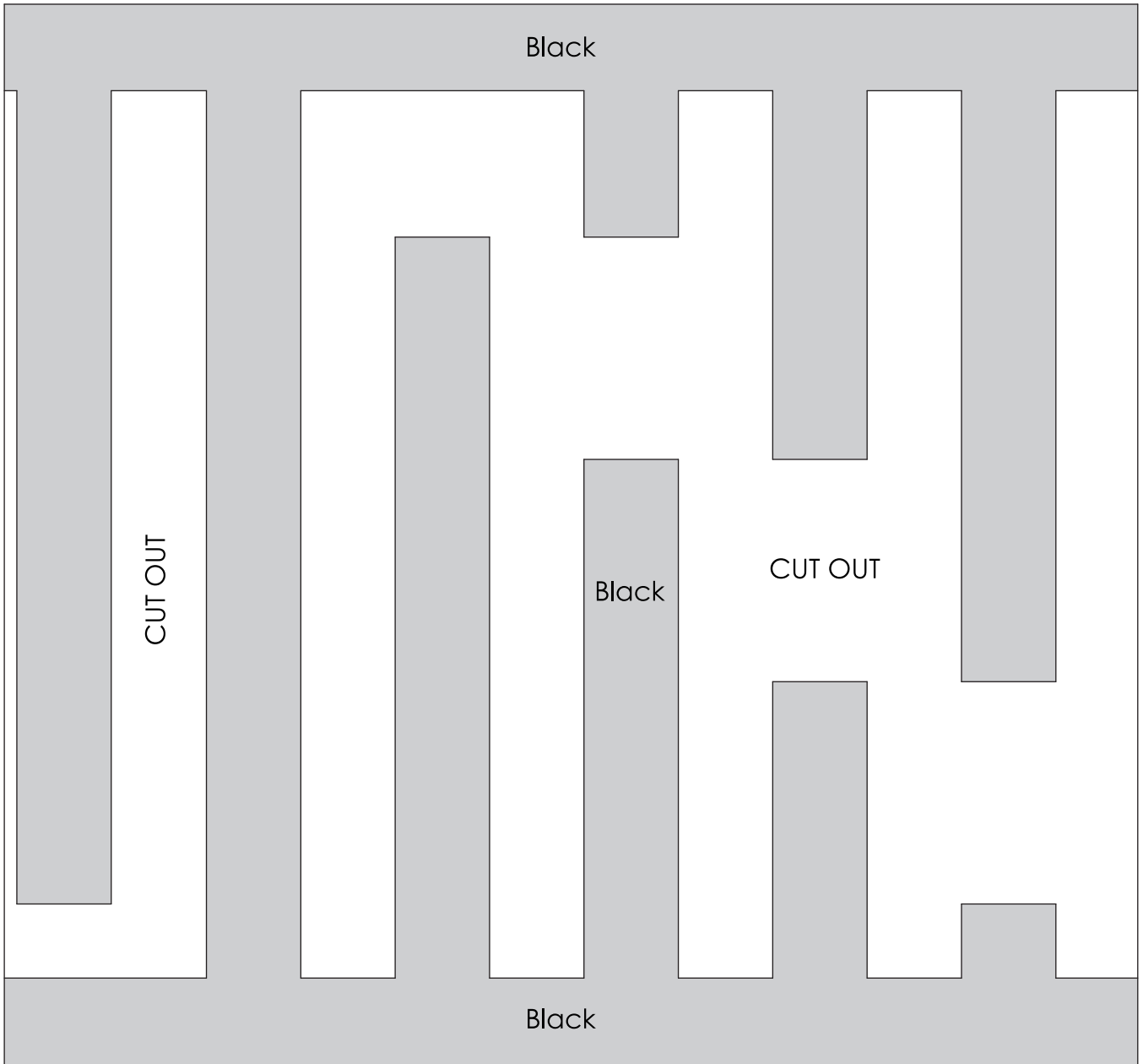

lower BT-70 paint mask