



EstesRockets.com

PRO SERIES II

SCORPIO™

9733/2326

AGES
18+



Skill Level

INTERMEDIATE

MODEL ROCKET INSTRUCTIONS

KEEP FOR FUTURE REFERENCE

IMPORTANT: Please record date found on decal and keep for future reference. _____

CAUTION:

May not apply to all kits. For safe handling of plastic cement, epoxy, spray adhesive, CA glue, CA accelerator, paint/finishing materials, see manufacturer's warnings and follow instructions for use. To avoid injury, use extreme caution when using hobby knife, scissors, drills, and any cutting tools.

SUPPLIES



HOBBY KNIFE



FINE SANDPAPER



EPOXY



CLEAR TAPE



MASKING TAPE



RULER



WHITE PRIMER



GRAY PAINT



CLEAR COAT (OPTIONAL)

Parts to be 3D printed

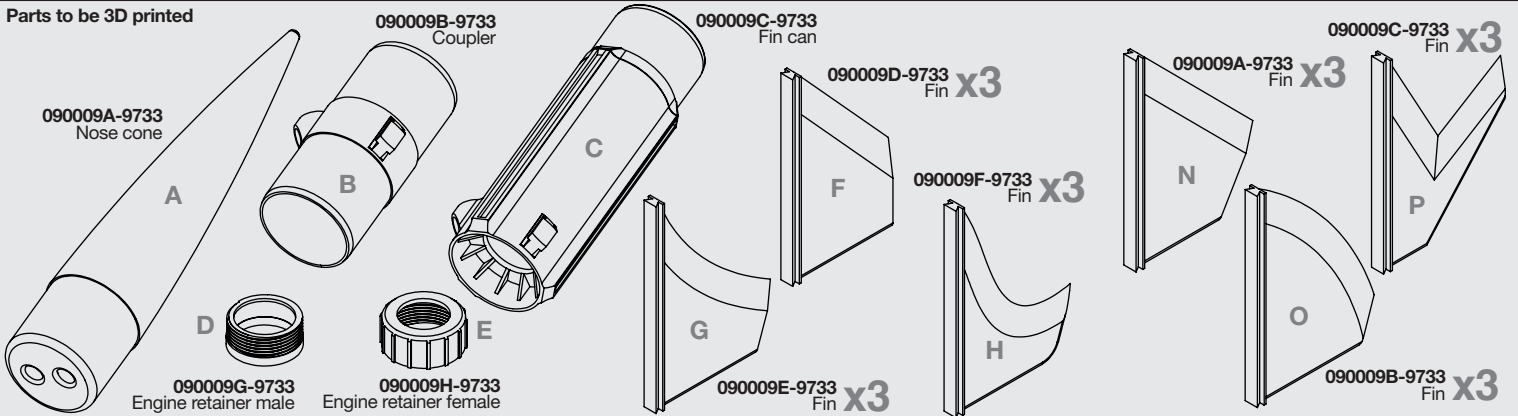

090009A-9733
Nose cone

090009B-9733
Coupler

090009C-9733
Fin can

090009D-9733
Fin x3

090009C-9733
Fin x3

090009A-9733
Fin x3

090009F-9733
Fin x3

090009E-9733
Fin x3

090009B-9733
Fin x3

090009G-9733
Engine retainer male

090009H-9733
Engine retainer female

031360
Engine mount tube

030615
Body tube x2

038374
Shock cord

038358
300# Aramid cord

302247
24 in. Rip stop parachute

090001-9733
Water slide decals

3D PRINT PARTS ORIENTATION AND SETTINGS

General Printer Setting Recommendations:

- Recommended filaments: PLA+, PETG, ABS.
- No supports necessary (support settings are at the consumers discretion if they are desired).
- Wall thickness of 3 lines wide with a 0.4mm nozzle.
- 7 Percent infill (gyroid).
- Use of a 3mm or wider brim is recommended for bed adhesion.

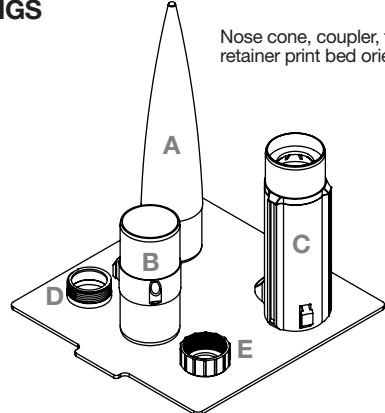

Nose cone, coupler, fin can, and engine retainer print bed orientations.

Fin print bed orientations.

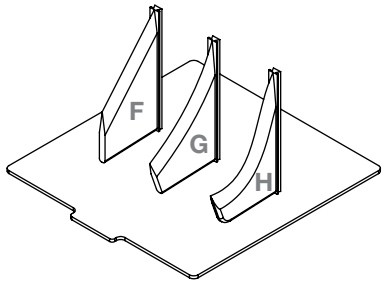

3D PRINT POST PROCESSING

1. Use a sharp hobby knife to carefully separate the fin locking ring by slowly cutting around the circumference, so that it can rotate freely. Be careful not to cut too deep.

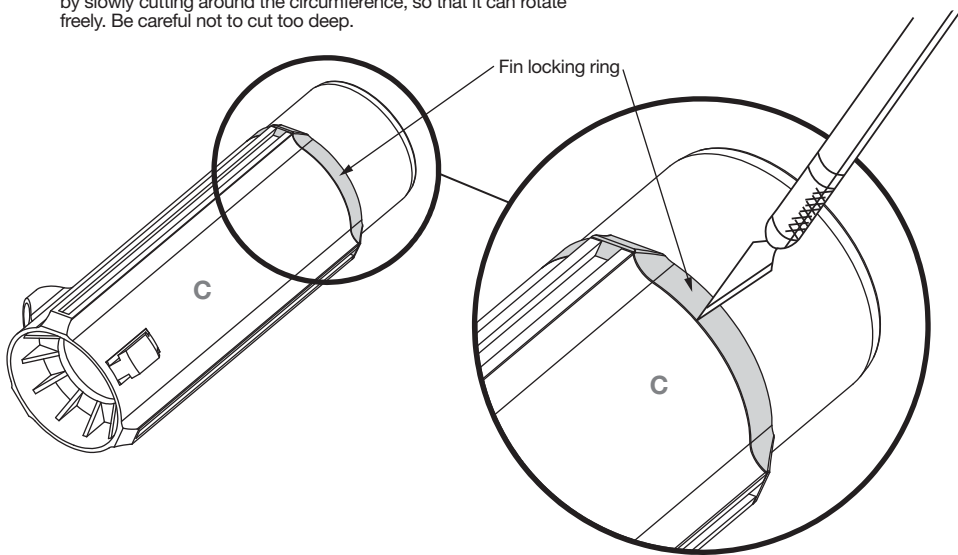

2. Locking ring should be able to move in either direction.

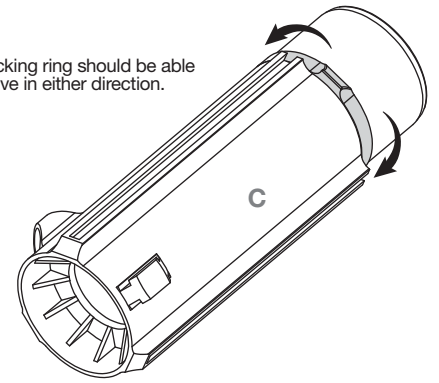

NOTE:

On any parts that a brim was applied, remove excess plastic to ensure a proper fit.

NOTE:

Test fit parts together before gluing. Sand off any burrs causing fit issues.

ASSEMBLE FIN CAN

1. Apply epoxy inside fin can C on the inside of the centering ring as shown below.

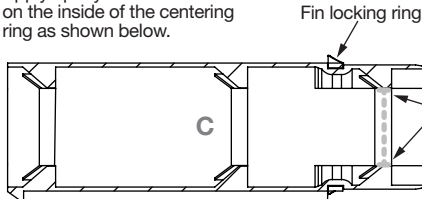

FIN CAN CROSS SECTION

Fin locking ring

2. Apply epoxy 1 in. from end of engine mount tube I. Insert tube I into fin can C.

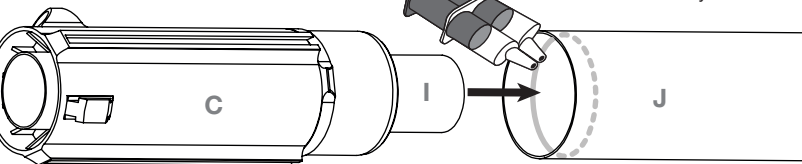
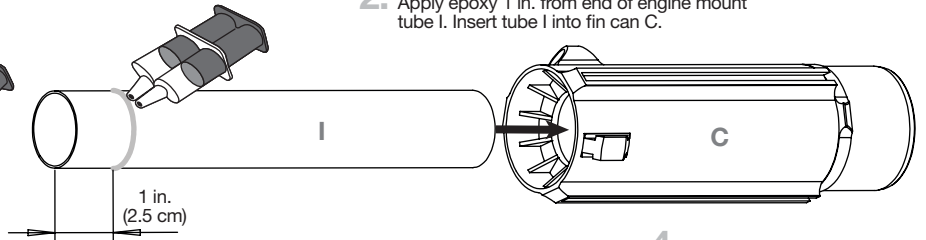

4. Apply epoxy to the inside of one body tube J. Insert fins can into body tube.

3. Make sure the end of tube I and fin can C are flush.

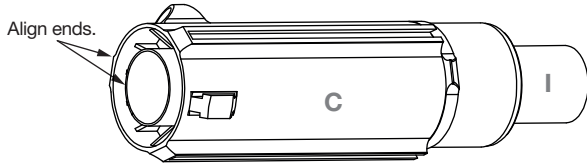

LET DRY

NOTE:

Ensure no epoxy gets on the fin locking ring. It must remain free to rotate.

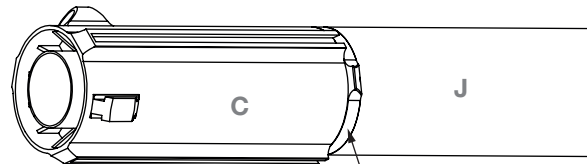

Fin locking ring

LET DRY

UPPER BODY ASSEMBLY

1. Apply epoxy inside tube J. Insert the open end of coupler B into tube J.



2. Be sure the launch lugs and rail guides are aligned.

NOTE:

Using a launch rod or rail can aid in aligning parts.



LET DRY

3. Tie Aramid cord K with a double knot onto eye hole of coupler B. Apply a dab of epoxy to the knot and let dry.

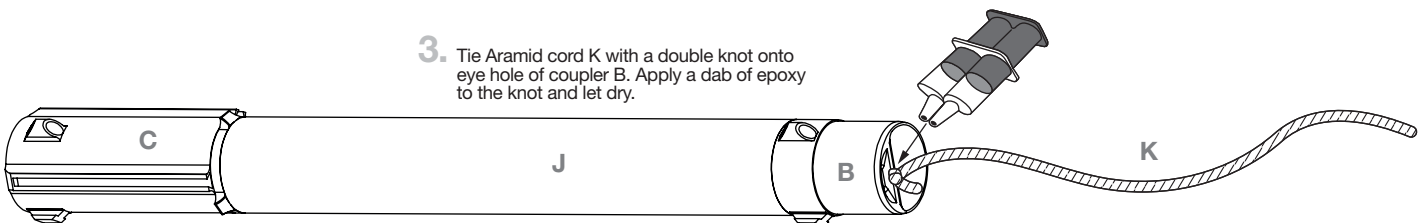

UPPER BODY ASSEMBLY (CONTINUED)

4. Apply epoxy to the inside of the other body tube J. Thread Aramid cord K through the body tube. Insert coupler B into tube J.

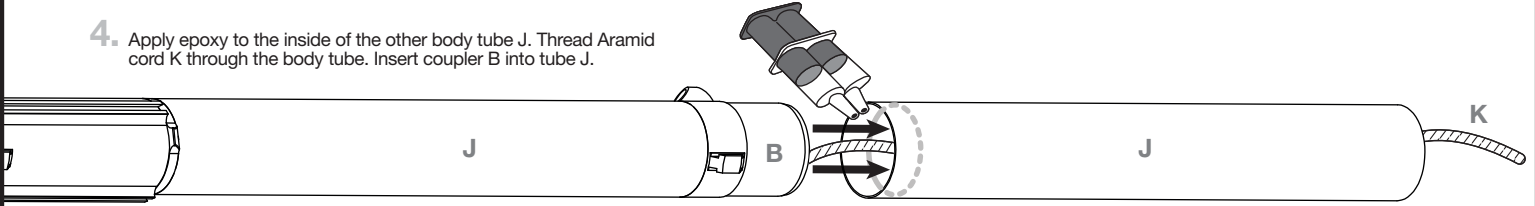

5.

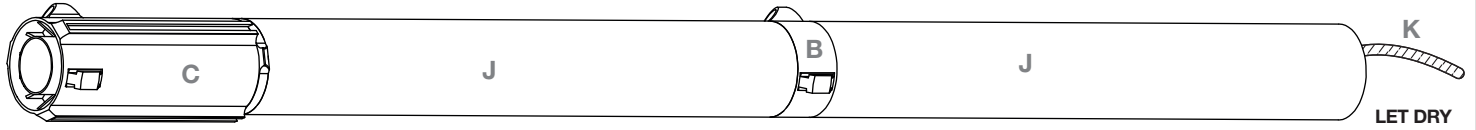

ATTACH ENGINE RETAINER

1. Roughen inside of engine retainer D with sandpaper.



2. Apply epoxy to engine mount tube.

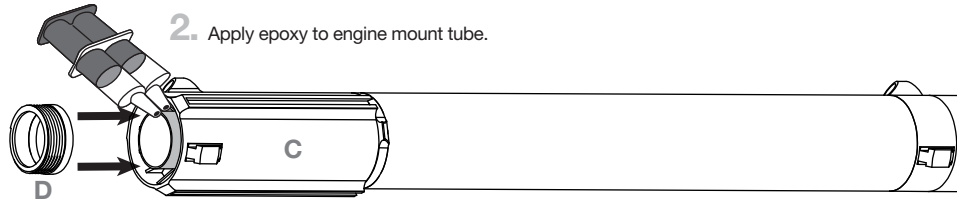

3. Place engine retainer over engine mount tube until ends are flush. LET DRY

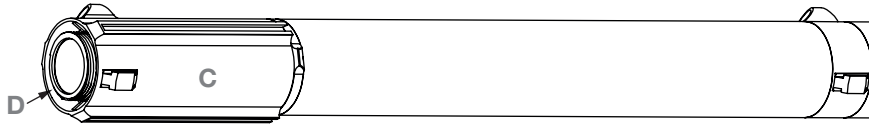

ASSEMBLE RECOVERY SYSTEM

1. Tie a loop at the end of Aramid cord K using a double knot.

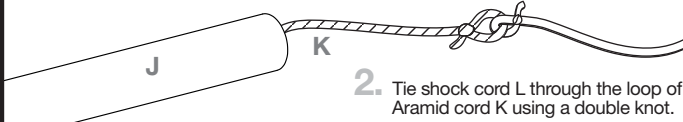

2. Tie shock cord L through the loop of Aramid cord K using a double knot.

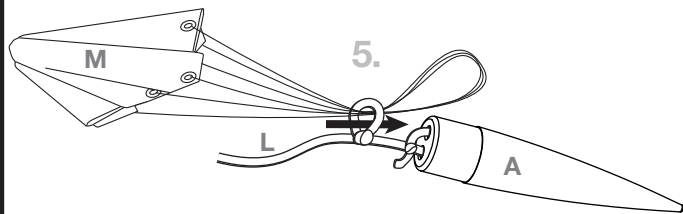

3. Tie a loop 6 in. from the free end shock cord L.

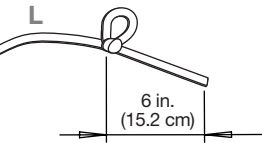

4. Loop the free end of the shock cord through the holes in nose cone A. Tie shock cord in a double knot.

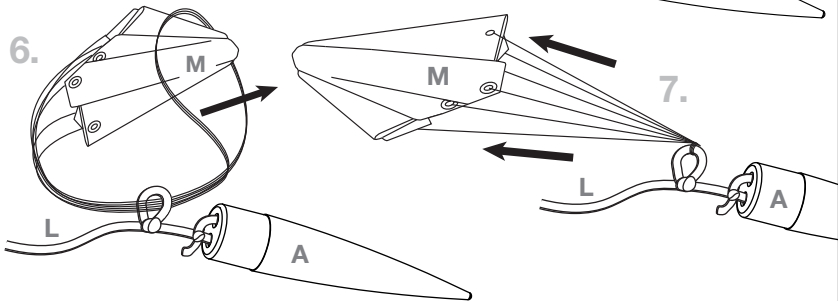
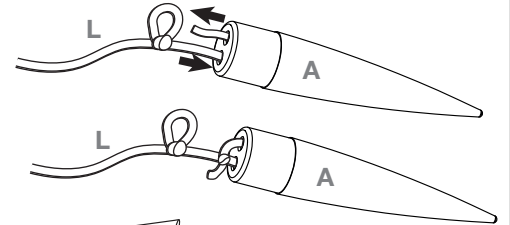

FIN ASSEMBLY

1. Move fin locking ring into open position.

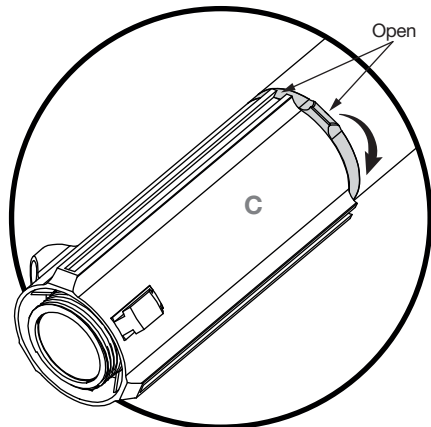

2. Slide fin into groove in fin can.

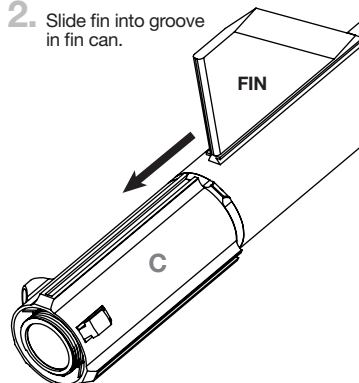

NOTE:
Do NOT orient fins upside down. Only orient fins with tapered leading edge facing up.

3. Repeat for all 3 fins.

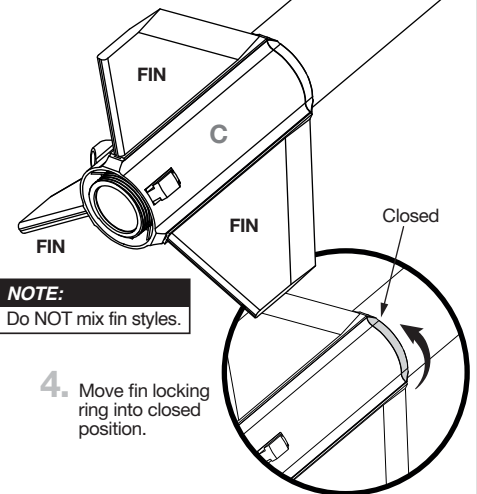

NOTE:
Do NOT mix fin styles.

4. Move fin locking ring into closed position.

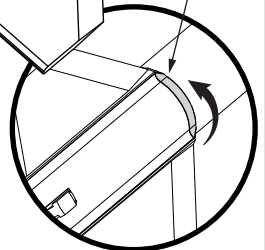

PREPARE RECOVERY

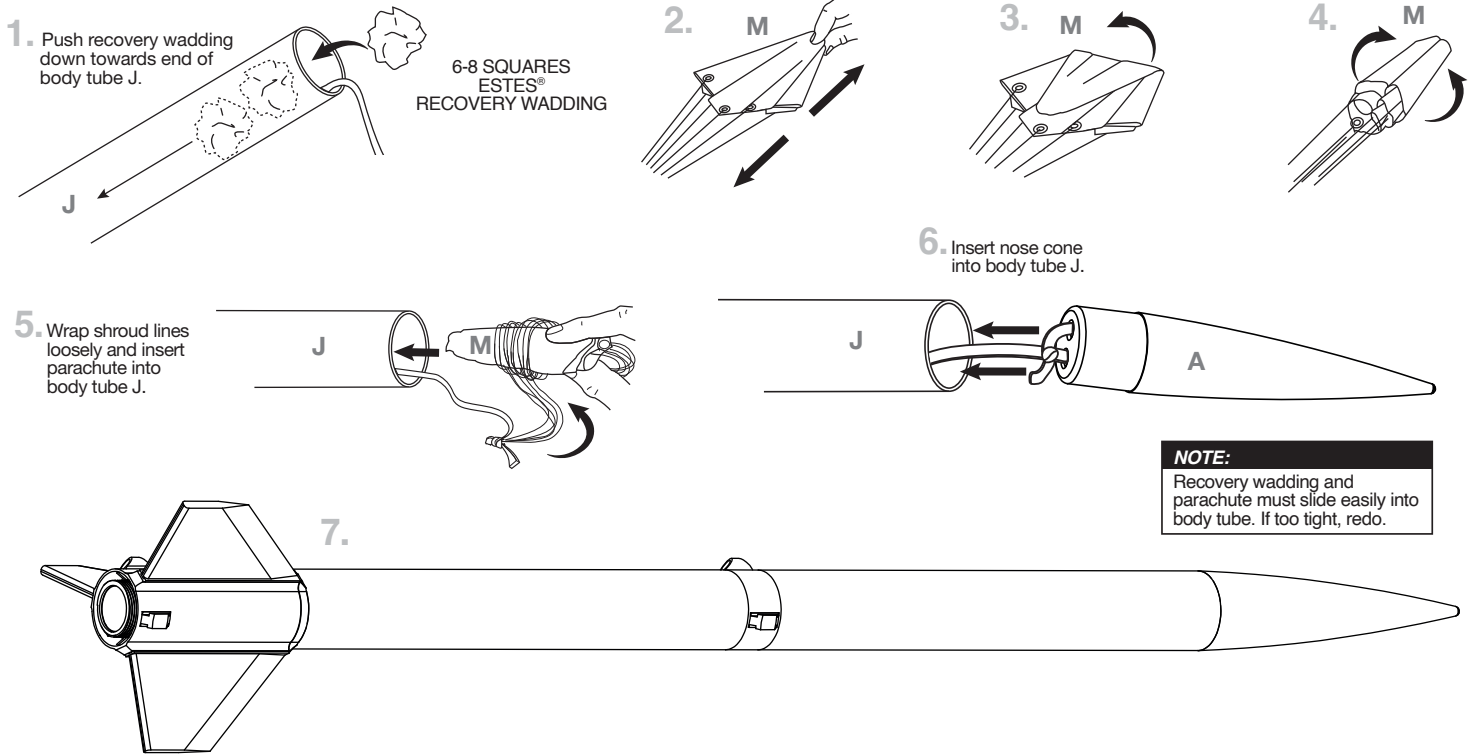

PREPARE ENGINE

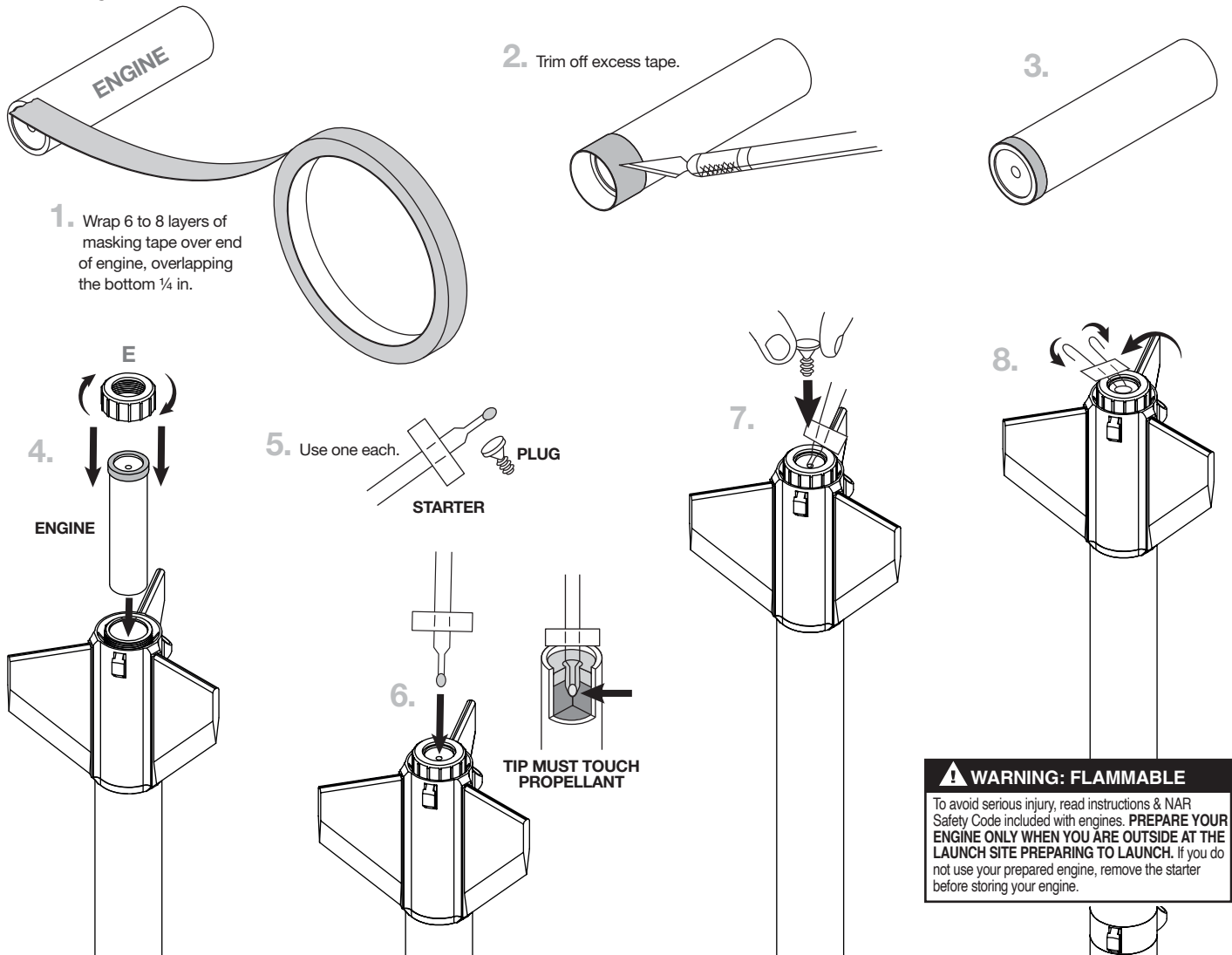

INSTRUCTIONS FOR ADDITIONAL FINS (2326) - SOLD SEPARATELY

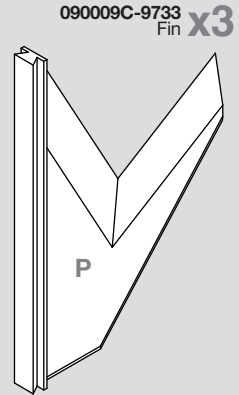
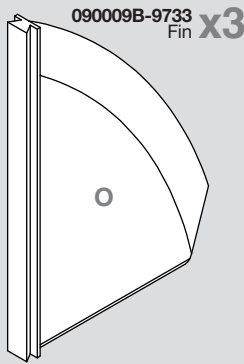
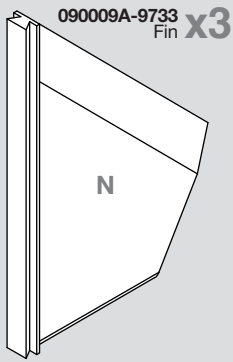

Fin print bed orientations.

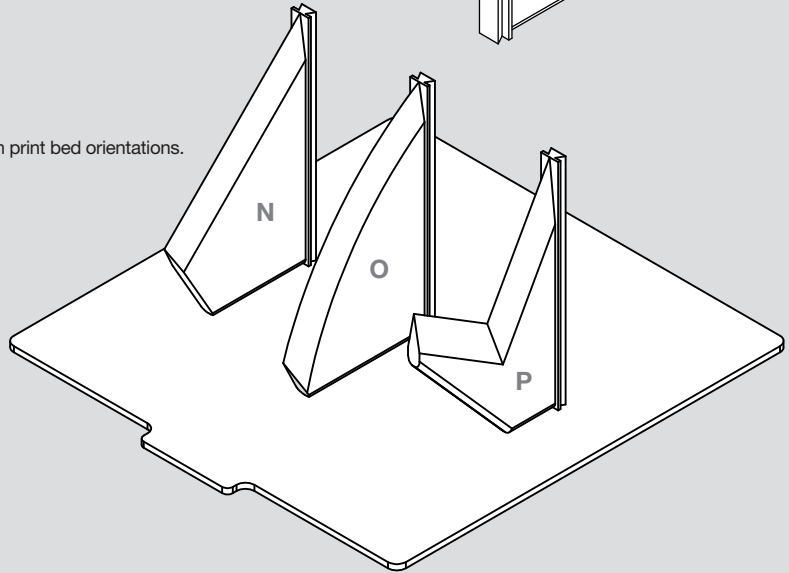

General Printer Setting Recommendations:

- Recommended filaments: PLA+, PETG, ABS.
- No supports necessary (support settings are at the consumers discretion if they are desired).
- Wall thickness of 3 lines wide with a 0.4mm nozzle.
- 7 Percent infill (gyroid).
- Use of a 3mm or wider brim is recommended for bed adhesion.

FIN ASSEMBLY

1. Move fin locking ring into open position.

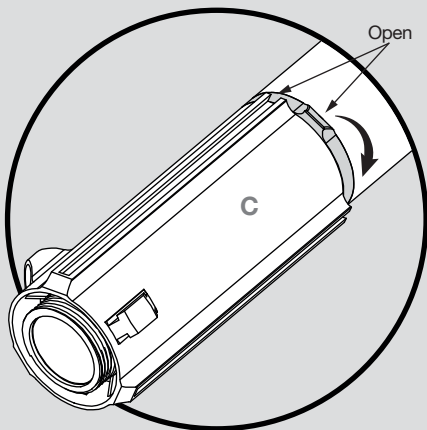

2. Slide fin into groove in fin can.

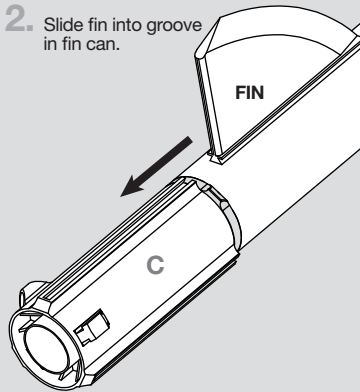

3.

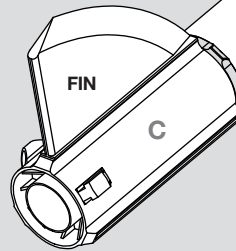

5. Move fin locking ring into closed position.

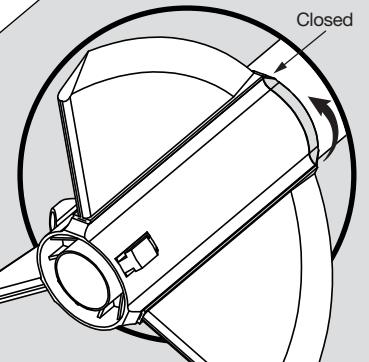

4. Repeat for all 3 fins.

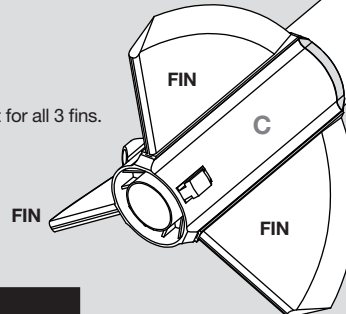

FIN CROSS SECTION

Sand or add tape.

NOTE:

Do NOT orient fins upside down. Only orient fins with tapered leading edge facing up.

NOTE:

If fin fit is too tight, sand root edge. If fin fit is too loose, add tape.

NOTE:

Do NOT mix fin styles.

COUNTDOWN AND LAUNCH

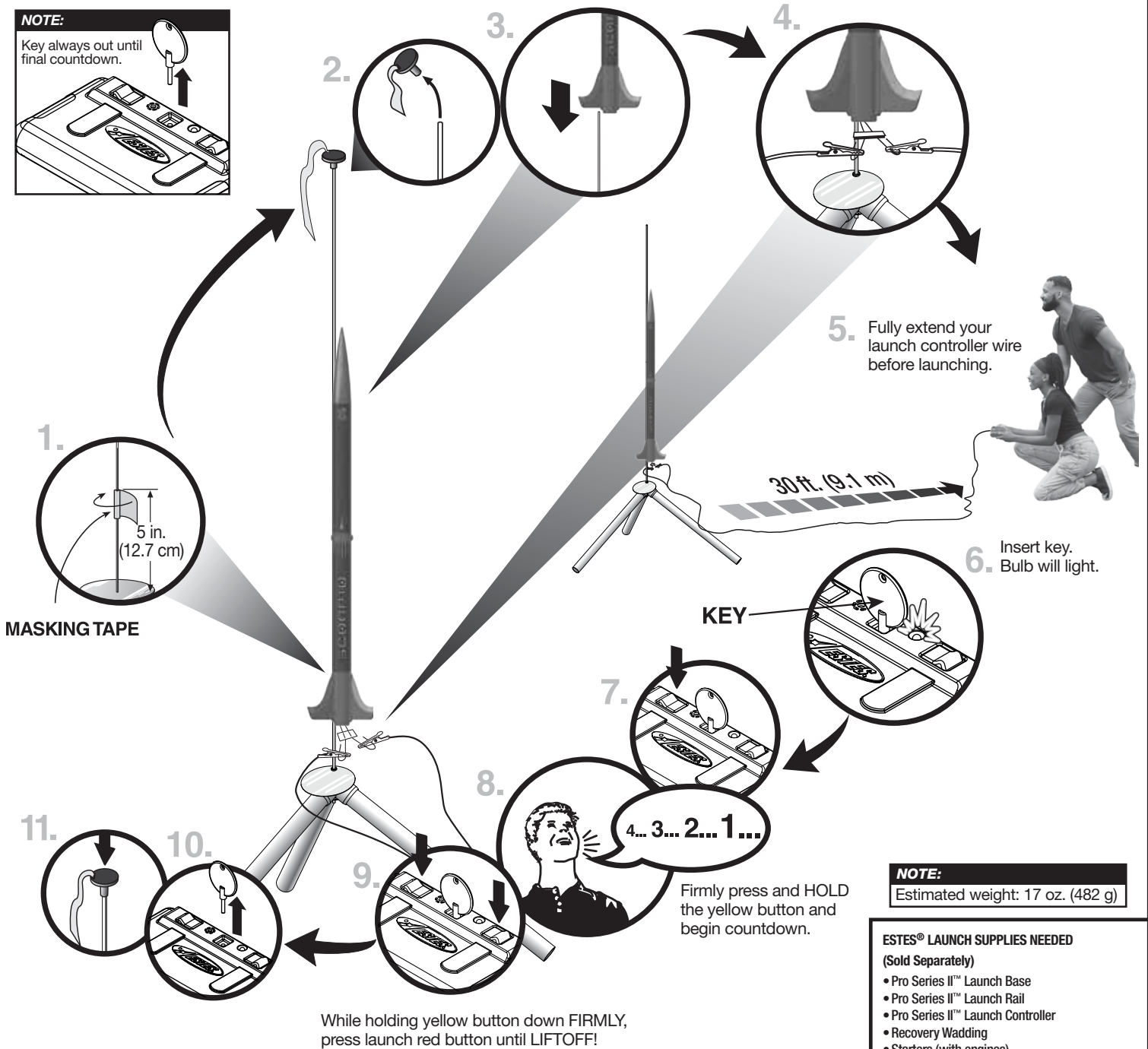
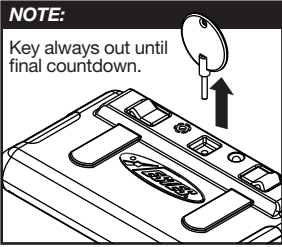

PRECAUTIONS



NAR SAFETY CODE



NO DRY GRASS OR WEEDS

PRE-LAUNCH CHECK For safety, never launch a damaged rocket. Check the rocket's body, nose cone and fins. Also, check the engine mount, recovery system and launch lug(s). Repair any damage before launching the rocket.

FLYING YOUR ROCKET Choose a large field (1000 ft. [305 m] square) free of dry weeds and brown grass. The larger the launch area, the better your chance of recovering your rocket. Launch only with little or no wind and good visibility. Always follow the National Association of Rocketry (NAR) SAFETY CODE (enclosed).

MISFIRES TAKE THE KEY OUT OF THE CONTROLLER. WAIT ONE MINUTE BEFORE GOING NEAR THE ROCKET. Disconnect the micro-clips and remove the engine. Take the plug and starter out of the engine. A burned starter means the starter tip was not touching engine propellant. Install a new starter; be sure the tip is touching propellant inside the engine. Push the plug in place. Repeat steps under Countdown and Launch.

