



EstesRockets.com

AGES  
18+

# APOLLO 11 SATURN V

1967



Skill Level

**MASTER**

## MODEL ROCKET INSTRUCTIONS

### KEEP FOR FUTURE REFERENCE

**IMPORTANT:** Please record date found on decal and keep for future reference. \_\_\_\_\_

**READ ALL INSTRUCTIONS.** Make sure you have all parts and supplies. Test fit all parts before applying glue.

On May 25th, 1961 President John F. Kennedy issued a challenge to Congress that he felt would "... hold the key to our future on Earth." The call to put a man on the moon was sounded, and the answer still resounds throughout the world today. It is hard to imagine the incredible effort it took to make "... one small step for man, one giant leap for mankind." At the time the decision was made to undertake a manned lunar landing, nothing even close to a rocket with the necessary capabilities existed. After an intensive evaluation and development process, the Saturn V was ultimately chosen as the best course of action.

On July 16th, 1969 the Saturn V launched Apollo 11 into space and history. It is truly mind boggling to attempt to conceive the influences still apparent in everyday life thanks to that mission, and even harder to believe that it was over 50 years ago. Here at Estes, we have decided to take a look back in order to imagine the future. The Saturn V has remained a much sought after kit throughout the years. We believe this is because the Saturn V ignites the imagination. Having accomplished putting a man on the moon reminds us all that the possibilities are endless. Enjoy building your Apollo 11 Saturn V, and all the dreams it may inspire.

### SUPPLIES:

#220, #320, #400 AND #600 SANDPAPER  
PENCIL  
TWEEZERS  
HOBBY KNIFE AND SEVERAL SHARP BLADES  
YELLOW GLUE  
TUBE-TYPE PLASTIC CEMENT  
LIQUID PLASTIC CEMENT  
PERMANENT SPRAY ADHESIVE (NOT ARTIST'S OR REPOSITIONABLE)  
CA  
CA FOR PLASTICS  
CA ACCELERATOR

CA ACCELERATOR FOR PLASTICS  
SANDING SEALER (OR SANDABLE AUTO PRIMER)  
SQUADRON GREEN OR WHITE PUTTY  
MASKING TAPE  
SMALL PAINT BRUSH  
FLAT BLACK ENAMEL BOTTLE PAINT  
FLAT BLACK ENAMEL SPRAY PAINT  
FLAT WHITE ENAMEL BOTTLE PAINT  
FLAT WHITE ENAMEL SPRAY PAINT  
ENAMEL SILVER SPRAY PAINT  
1/4" LAUNCH ROD  
NEEDLE NOSE PLIERS

### OPTION:

You may want bottle silver or enamel gunmetal spray paint instead of silver, "dull cote" spray paint. (Be sure to follow instructions and cautions.)

### NOTE:

Do not use lacquer based paints! They can melt the surface of the plastic parts.

### CAUTION

Please be extremely careful using cyanoacrylate adhesive (CA). Avoid getting in your eyes or on your skin. Safety glasses are recommended. Use adhesives and paint only in areas with adequate ventilation. Read all instructions.

### Before beginning to build with vac-formed plastic parts, read the following carefully.

#### Cutting Vac-Formed Parts

Cutting vac-formed plastic parts requires patience. Applying light pressure, make repeated passes with the blade to cut through the plastic. Be sure to keep the blade in the same cut line each time; too much pressure will cause the blade to move and not cut cleanly.

#### Sanding and Trimming Vac-Formed Parts

Once the part is free of excess plastic, sand the edges to remove any flash and to provide a smooth, flat bonding surface. Secure a sheet of #220 or #320 grit sandpaper to a flat surface. (You may want to use wet-or-dry sandpaper with a little water to avoid clogging or loading the sandpaper with plastic dust.) Move each part in a circle against the sandpaper with pressure evenly distributed to avoid uneven sanding. Applying too much pressure can cause uneven edges. When working with thin edges, be careful not to remove too much plastic or generate too much heat that may warp and destroy the part. **NOTE:** Double sided tape may be used to hold small parts. Use a file to remove excess plastic on hard to hold small parts.

#### Adhesives for Vac-Formed Parts

Because vac-formed parts are thinner than injection molded parts, different adhesives should be used. Three basic types give good results and you should have both on hand when building this model.

The first type is spray adhesive. We recommend 3M Super 77. Be sure to use it in a well ventilated area.

Second is liquid plastic cement. Our preferred brands are Plastic Weld Cement (Plastruc), Testor's Plastic Cement #3502, Tenax 7R, and Testor's or Tamiya glue pens.

Liquid cements work on styrene by dissolving the plastic and creating a chemically welded bond. As a result, a little bit goes a long way! Liquid cements are usually applied with an artists brush. The trick to using plastic cement is to take advantage of the liquid flowing out from the brush by allowing cement to bleed into close fitting parts and then squeezing the parts together to bond. Work on a small area at one time as plastic cement sets quickly.

The third adhesive to have on hand is a super glue or cyanoacrylate for plastics. We recommend Plasti-Zap. You'll also want to use CA accelerators for plastics for these, but use a toothpick or a pipette to apply accelerator one drop at a time. When sprayed from their normal applicators, most regular CA accelerators will soften and stain plastic surfaces.

#### Filling the Seams

This is a necessary step in constructing vac-formed models. Because these models have seams, they need to be filled and smoothed. The putties we recommend are 3M Accyl-Blue (Usually found at auto body supply shops - one tube will last a long time.) and Squadron Green or White Putty (usually found in hobby shops.)

When working with putty or filler use as little as possible. Excess putty in a seam creates extra work in sanding it away, as well as the possibility of a "sinkhole" (where the putty collapses the skin of the plastic and eats it away.) Use masking tape along seams to minimize excess putty from adhering to the work area. Use multiple layers when building up low areas, rather than one thick layer of putty. Doing so will reduce shrinkage, cracking, and the risk of sinkholes. Let the putty dry overnight before attempting to sand it away. Wet-or-dry sandpaper, used wet, works best. Start with #220 grit and work your way through #320 to #400. Then polish the area with #600.

**PARTS**

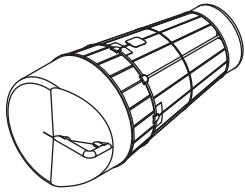

**072400**  
LEM shroud

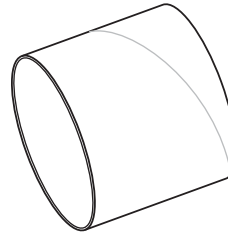

**030460**  
Spacer ring display coupler

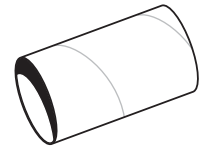

**046004**  
L.E.M. body tube

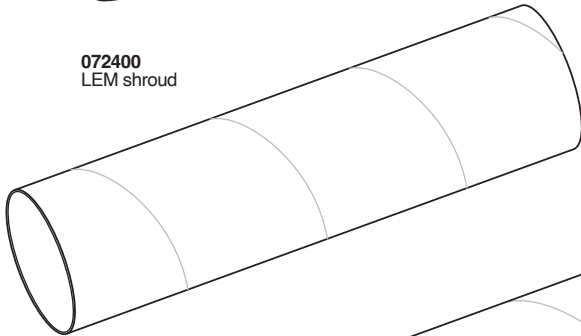

**030434**  
Third stage body tube

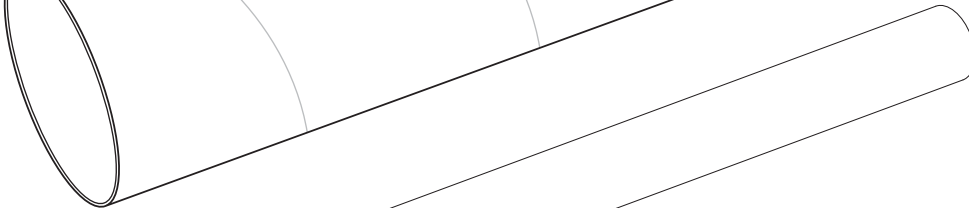

**030449**  
Main body tube



**031963**  
Engine mount tube

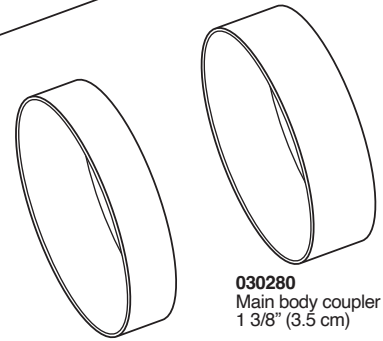

**030280**  
Main body coupler  
1 3/8" (3.5 cm)

**030281**  
Reinforcing ring  
1" (25 mm)

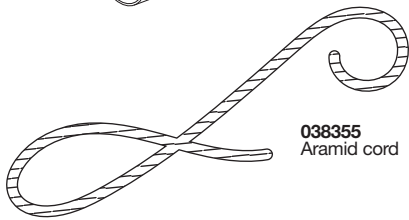

**038355**  
Aramid cord

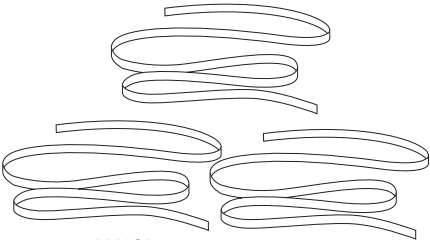

**038363**  
Shock cord

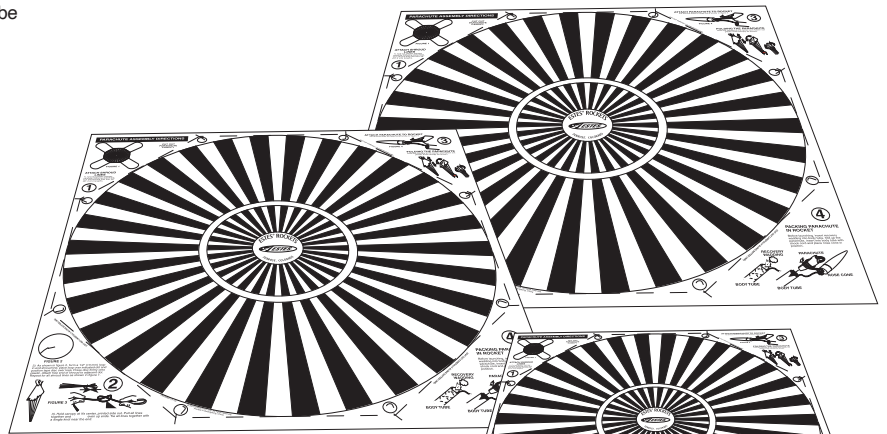

**035826**  
Parachute 24" (61 cm)

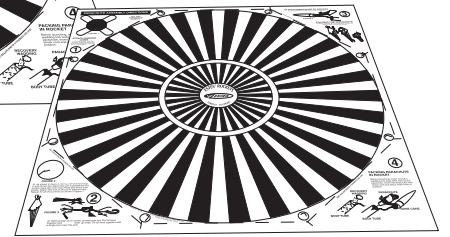

**035827**  
Parachute 18" (46 cm)

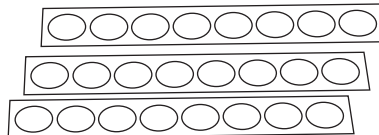

**038408**  
Tape disk strip

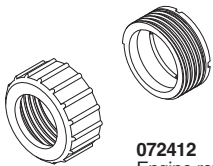

**072412**  
Engine retainer

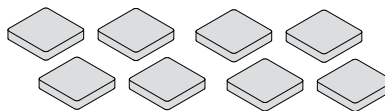

**085705**  
Clay

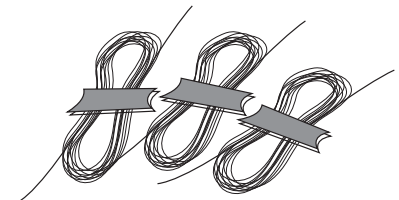

**038236**  
Shroud line (3 bundles)

**CARD STOCK**

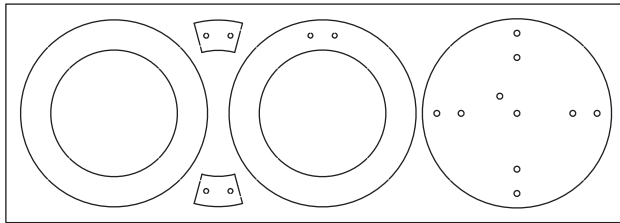

**090052C-1973**  
L/C centering rings

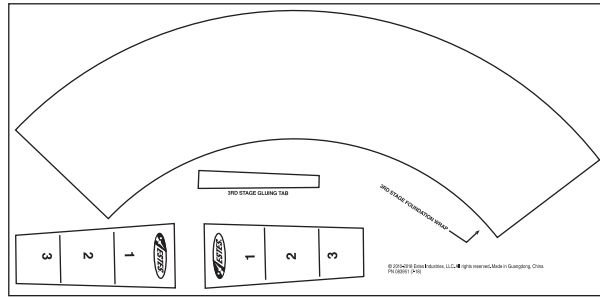

**083951**  
Printed card (shock cord mounts, 3rd stage foundation wrap)

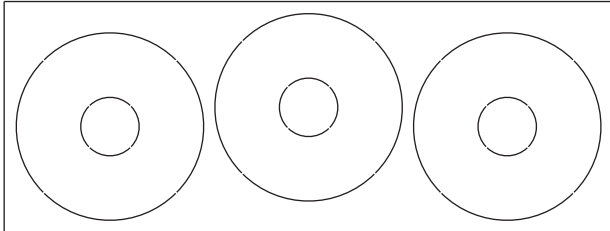

**090052A-1973**  
L/C engine mount centering rings

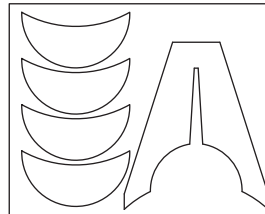

**090052B-1973**  
L/C Fin assembly parts

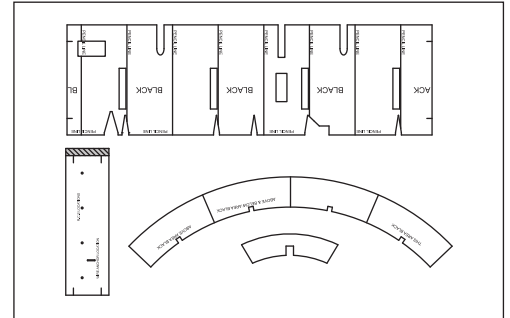

**090057-1967**  
Paint masking templates

**087091**  
**VACUUM FORMED PARTS**

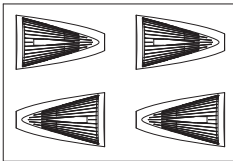

Fairing sheet

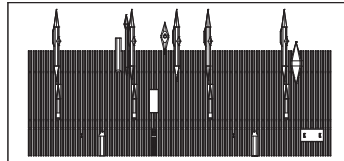

Second stage wrap

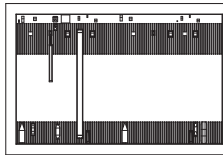

3rd stage wrap



Upper 2nd stage wrap

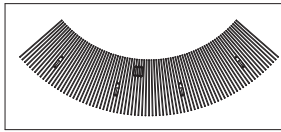

BODY WRAP REDUCTION

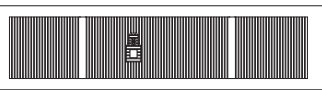

Intertank wrap

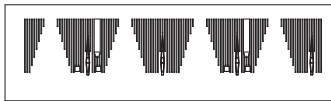

1st stage wrap

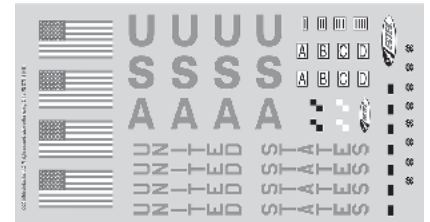

**090001-1973**  
Waterslide decal



**090001-1969**  
Waterslide decal

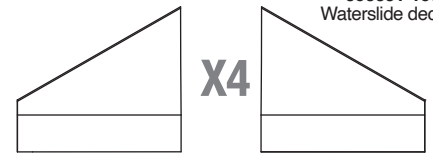

**073156**  
Injected molded fins

**PLASTIC PARTS**

**033201**  
Plastic parts set

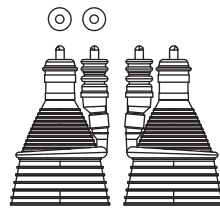
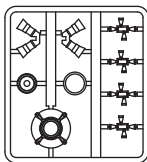

**X5**  
**033200**  
Engine nozzles



**038331**  
Brass wire



**030442**  
Escape motor body

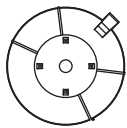

(This piece not needed)



**038265**  
Snap swivel



**038182**  
Launch lugs

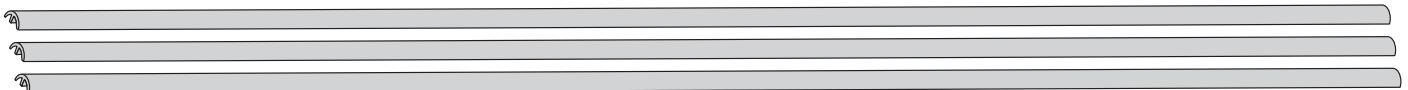

**033625**  
Half round tunnels

## MARK TUBES

1. Use a door frame as a guide to draw a straight line down the main and third stage body tubes.
2. Mark the alignment line on the main body tube at 3" (7.6 cm), 8 7/16" (21.4 cm), and 18 3/8" (46.7 cm). The end you measure from is now the REAR of the tube.
3. Mark alignment line as shown. This is now the FRONT of the tube.

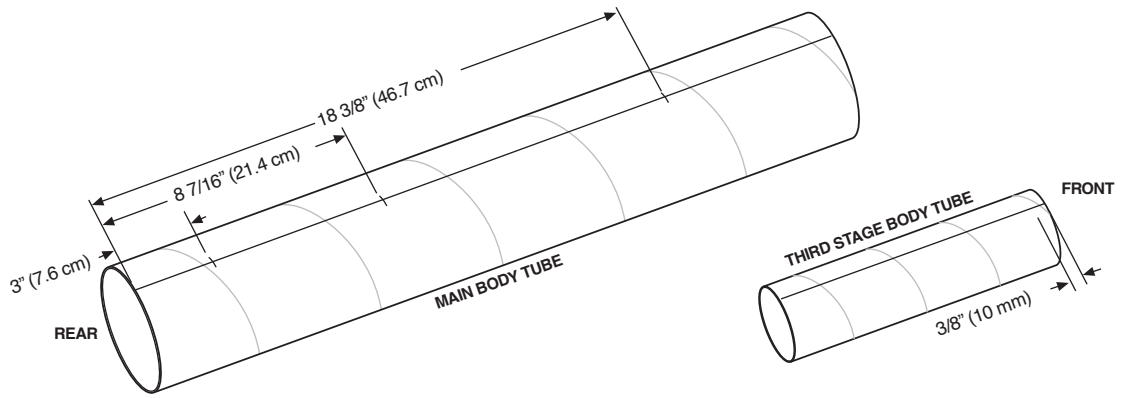
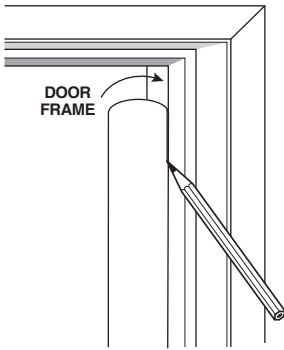

## ASSEMBLE ENGINE MOUNT

1. Mark three circular spots on the side of the tube.
2. Mark 1/8" (3 mm) and 8 1/8" (20.6 cm) from the REAR end.
3. Rough up inside surface with sandpaper. **FINE SANDPAPER**
4. Attach engine retainer with epoxy. Mix and apply according to epox instructions. Let dry.
5. Apply glue on marks made in step 1.
6. Let dry.

**CAUTION:**  
For safe handling of epoxy, see manufacturer's warnings and follow instructions for use.

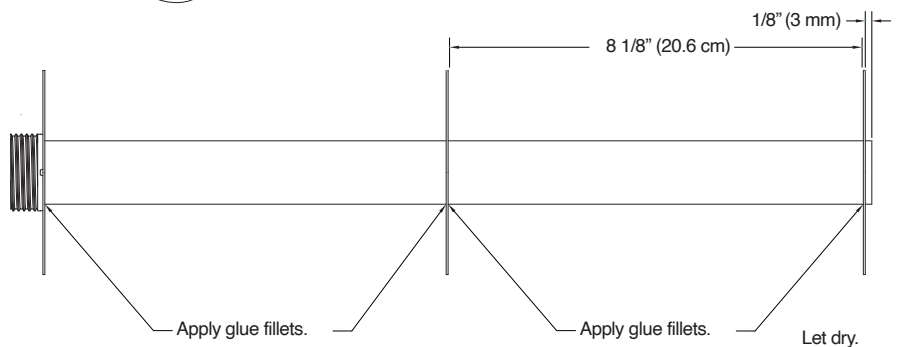

## INSTALL ENGINE MOUNT AND CENTERING RINGS

1. Slide the engine mount into the body tube until the rear ring is  $3\frac{3}{8}$ " (8.6 cm) from the rear end of the body tube. Apply a bead of glue to the ring/tube joints at each end, let dry, then fillet the joints.

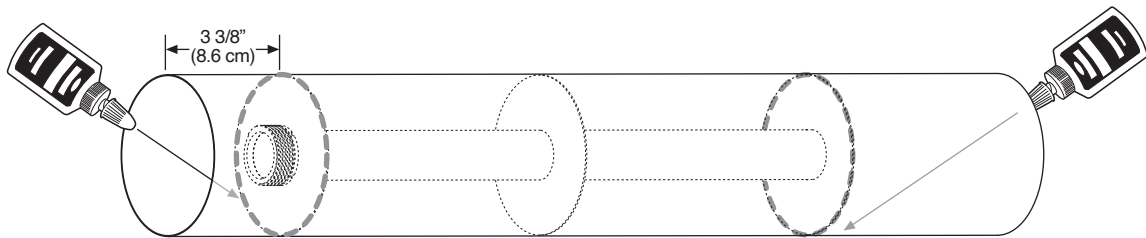
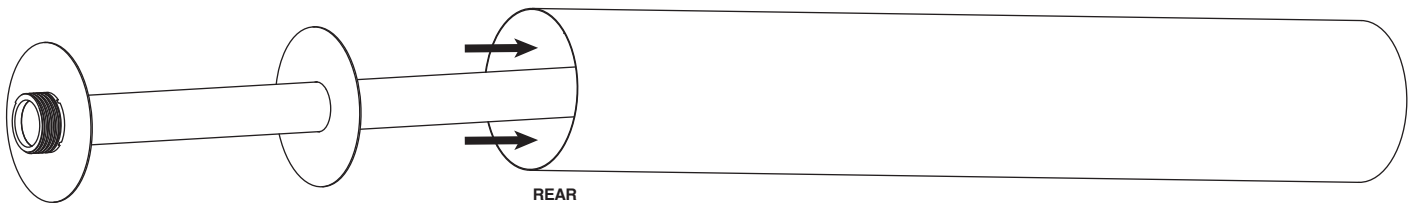

2. Apply a bead of glue around inside of tube assembly at rear of tube as shown. Insert reinforcing ring inside of tube assembly leaving  $\frac{3}{4}$ " (19 mm) of tube assembly exposed. Let dry.

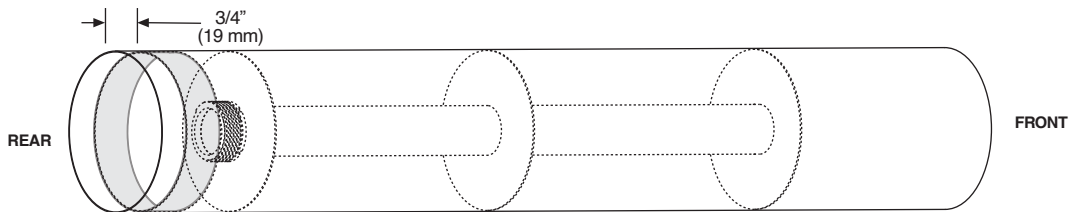
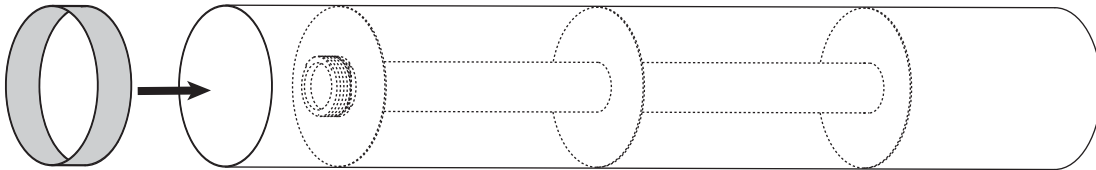
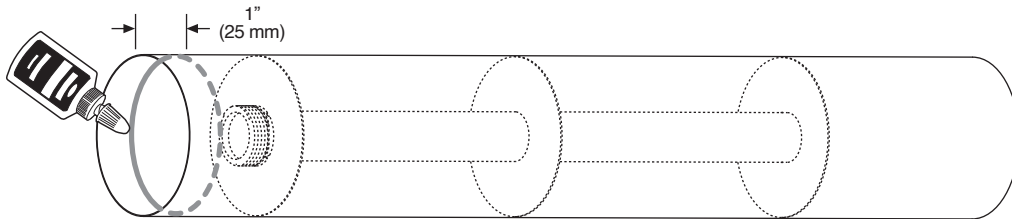

COMPLETED ASSEMBLY

**NOTE:**

Be sure to take note of the front and back of engine mount assembly.

3. Carefully extend the marks you made on the main body tube alignment line all the way around the tube, making sure the rings you draw are straight. (Use a thick piece of paper or masking tape as an aid in drawing the rings.)

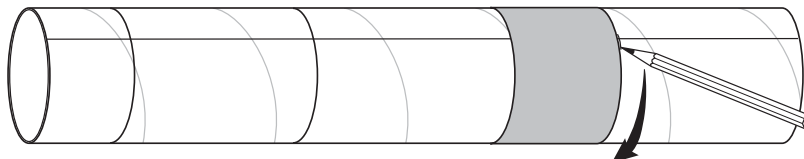

## INSTALL THIRD STAGE CENTERING RINGS

- 
- 
- 
- 
- Apply glue to the bottom inside edge of main body coupler.
- Use the end of a pencil to push down the ring.

**NOTE:**  
Join parts on a flat surface.
- Apply glue to the outside back edge of third stage body tube.
- 
- Cut a 6 in. piece of aramid cord. Thread through holes and tie a double knot.
- Glue the center from one of the laser cut rings onto the bottom of the tube/coupler assembly.
- 
- Apply glue to inside edge of coupler.
- Apply glue around ring and tube joint.

## INSTALL THIRD STAGE FOUNDATION WRAP

- Carefully cut along the outside edges of the third stage foundation wrap and glue tab. Curl the wrap, use low tack masking tape to tape the ends together, and glue the tab to the inside seam leaving about 1/16" (2 mm) of clearance at both the top and bottom as shown. Let dry.
- Slide the wrap onto the coupler, draw a line around the body tube at the front of the wrap, and remove. Apply a ring of glue around the tube at the mark, and slide the wrap back into place making sure to align the seam in the wrap with the alignment line on the tube.

## ASSEMBLE AND INSTALL NOZZLES

1. Use a hobby knife to remove and trim the nozzle halves and supply tubes from the plastic sprue. Use liquid plastic cement or plastic CA to glue the nozzle halves together, and then to attach the supply tubes. Be sure to note that the middle (heavy) portion of the tubes point down toward the nozzles. Hold tubes in place until cement sets, check that tube is straight, and let dry.
2. Paint the nozzle assemblies gun metal gray or silver and let dry overnight.
3. Use a hobby knife to remove the bulkhead from its laser-cut card. Position the bulkhead over the nozzles. Place the plastic washers over the nozzle nubs on bulkhead. Use the spacer ring to press the bulkhead down onto nozzles and to ensure that the nozzles all sit evenly on a flat surface. You will notice that the spacing between the spacer ring and the washers is tight. Position the washers so that they do not interfere with the fit of the spacer ring to the bulkhead.

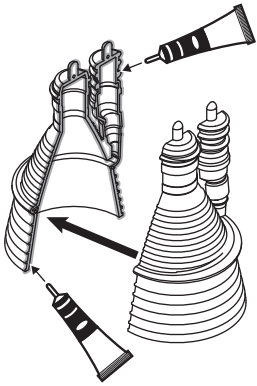

**CAUTION:**  
For safe handling of plastic cement, see manufacturer's warnings and follow instructions for use.

X5

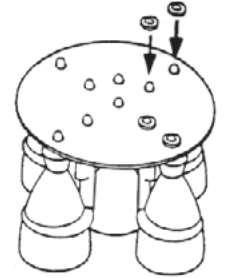
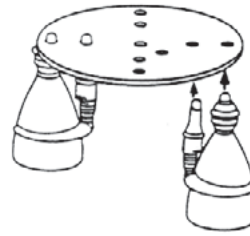
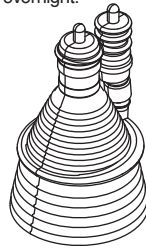

4. Use liquid plastic cement or plastic CA to glue the washers in place and let dry.

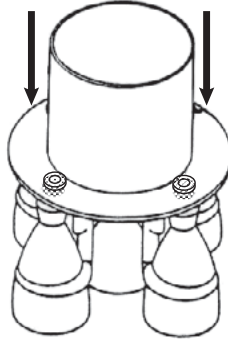

5. Remove the spacer ring, apply yellow glue and reposition on bulkhead.

**NOTE:**  
For display purposes only. Remove for flight.

## APPLY TUBE WRAPS

1. Orient wraps according to the diagram and lightly mark the top of each wrap for later reference. Be sure to note and mark the top of the inter tank wrap before removing from sheet. Use a hobby knife to carefully remove the vac-form wraps from the excess plastic cutting along the corrugation on the left side and leaving some excess plastic on the right. Test fit and trim as necessary. Use the dimensions shown to cut the lower 1st stage wrap from the vac-form sheet.

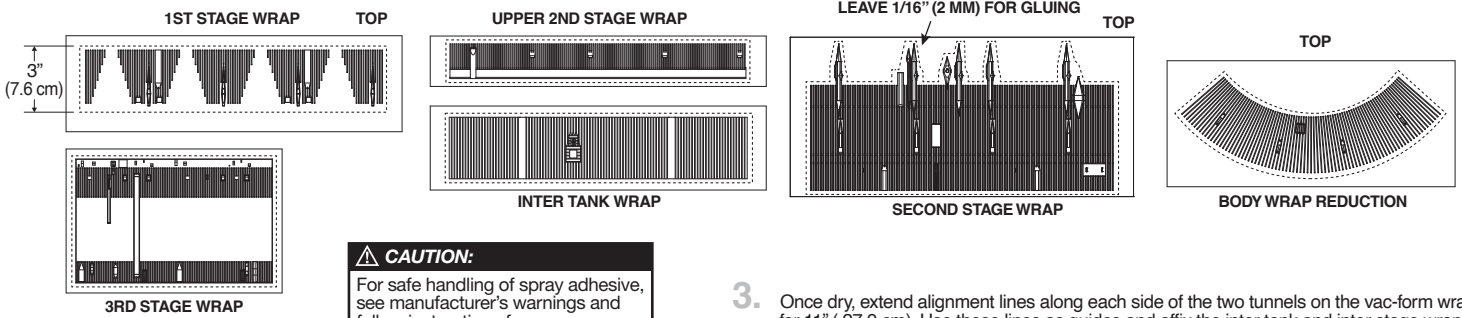

2. Lightly spray the lower 1st stage wrapper with spray adhesive, align the edge of the wrapper with the alignment line on the main body tube, and apply wrapper to the 3" (7.6 cm) ring you drew earlier.

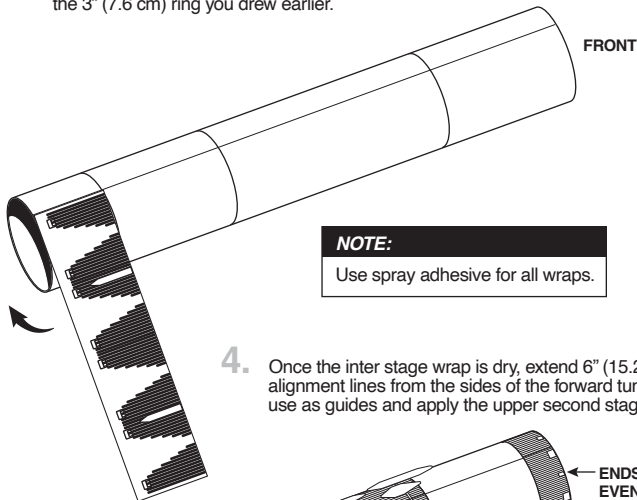

3. Once dry, extend alignment lines along each side of the two tunnels on the vac-form wrap for 11" (27.9 cm). Use these lines as guides and affix the inter tank and inter stage wraps. (Be sure your tunnel locations line up).

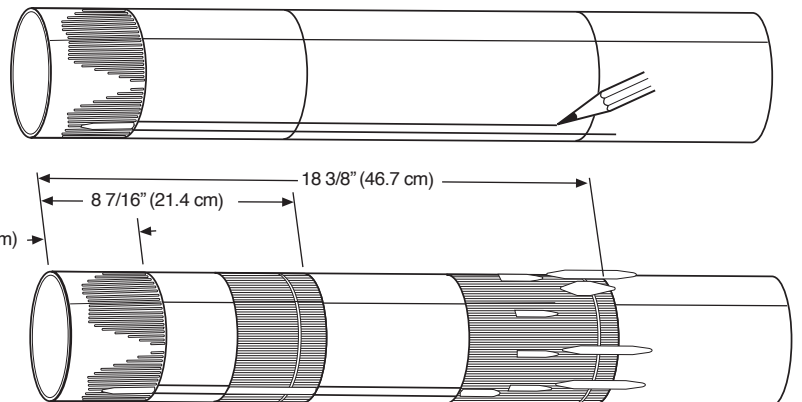

4. Once the inter stage wrap is dry, extend 6" (15.2 cm) alignment lines from the sides of the forward tunnel to use as guides and apply the upper second stage wrap.

5. Apply the upper third stage wrapper to the third stage body tube shown on the third stage assembly. Apply body wrap reduction.

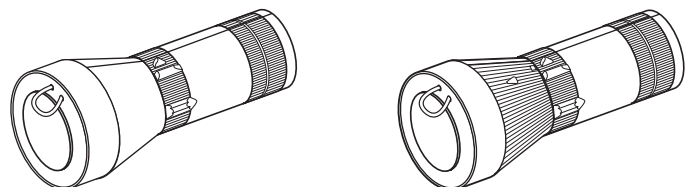
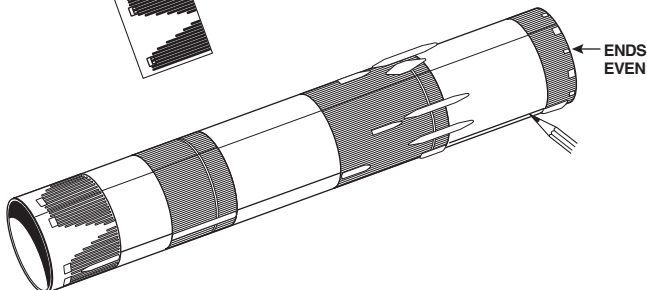

## ASSEMBLE FINS

1.

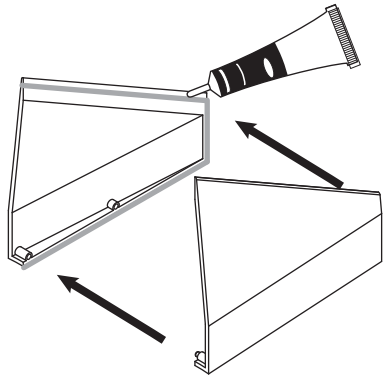

2. Let dry.

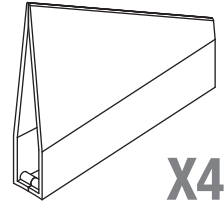

## PREPARE FAIRINGS

1. Use a hobby knife to carefully remove the fairings, leaving 1/16" (2 mm) of flash.

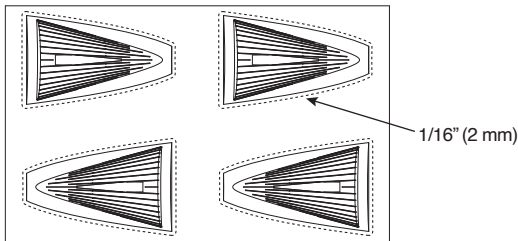

2. Use a hobby knife to carefully remove the fairing bases and the alignment guide.

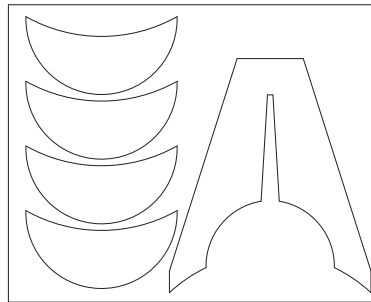

3. Use plastic cement to attach the fairing bases to the inside bottom of the fairings.

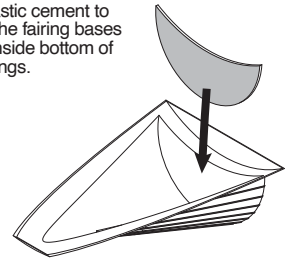

4. Let dry.

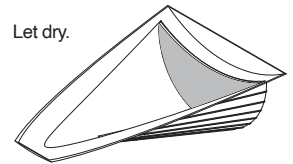

5. Use a hobby knife to carefully remove the flashing from the fairings.

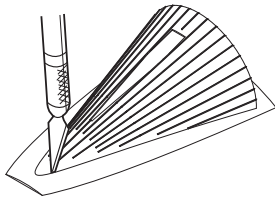

6. Remove the fin slot indentations and bottom ledge from each fairing.

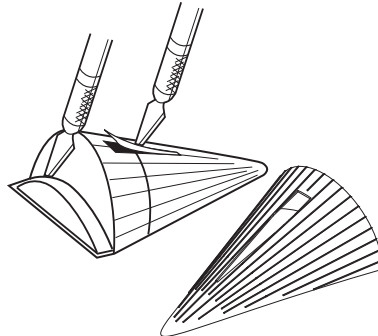

7. Test fit, trim, and sand each fairing to fit each fin and each fairing to fit on the lower first stage wrap.

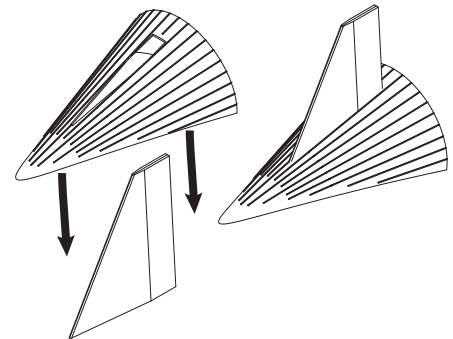

8. Test fit fin and shroud at location shown. Use card stock alignment guide for correct positioning.

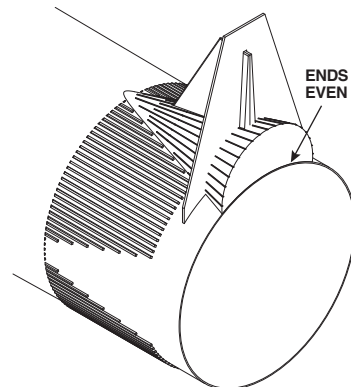
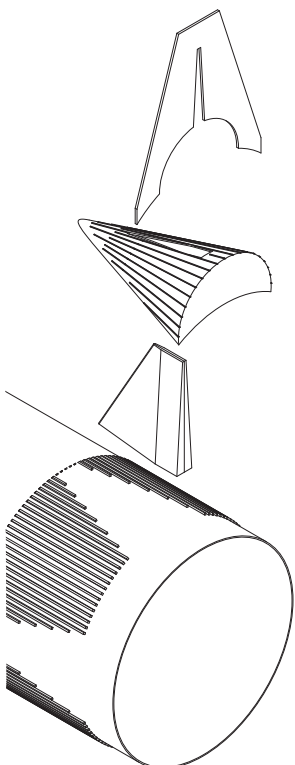

9. Trim as needed for a perfect fit.

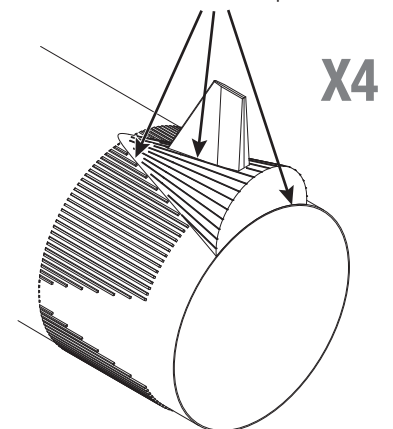
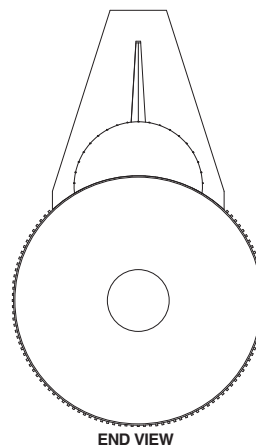

## ATTACH FINS AND FAIRINGS

1. Apply plastic cement to root edge of fin. Use shroud and card stock alignment guide for correct placement.

2. Hold in place until glue sets.

3. Remove fairing and apply glue fillet around fin joint.

4. Apply plastic cement as indicated and replace fairing.

5. When fins and fairings are dry, apply a reinforcing coating of liquid cement to the fin, fairing, and wrap joints. Let dry. Fill any holes with putty and sand flush.

6. Once the fairings are permanently affixed, cut away the areas on the tube up to the reinforcing ring where shown.

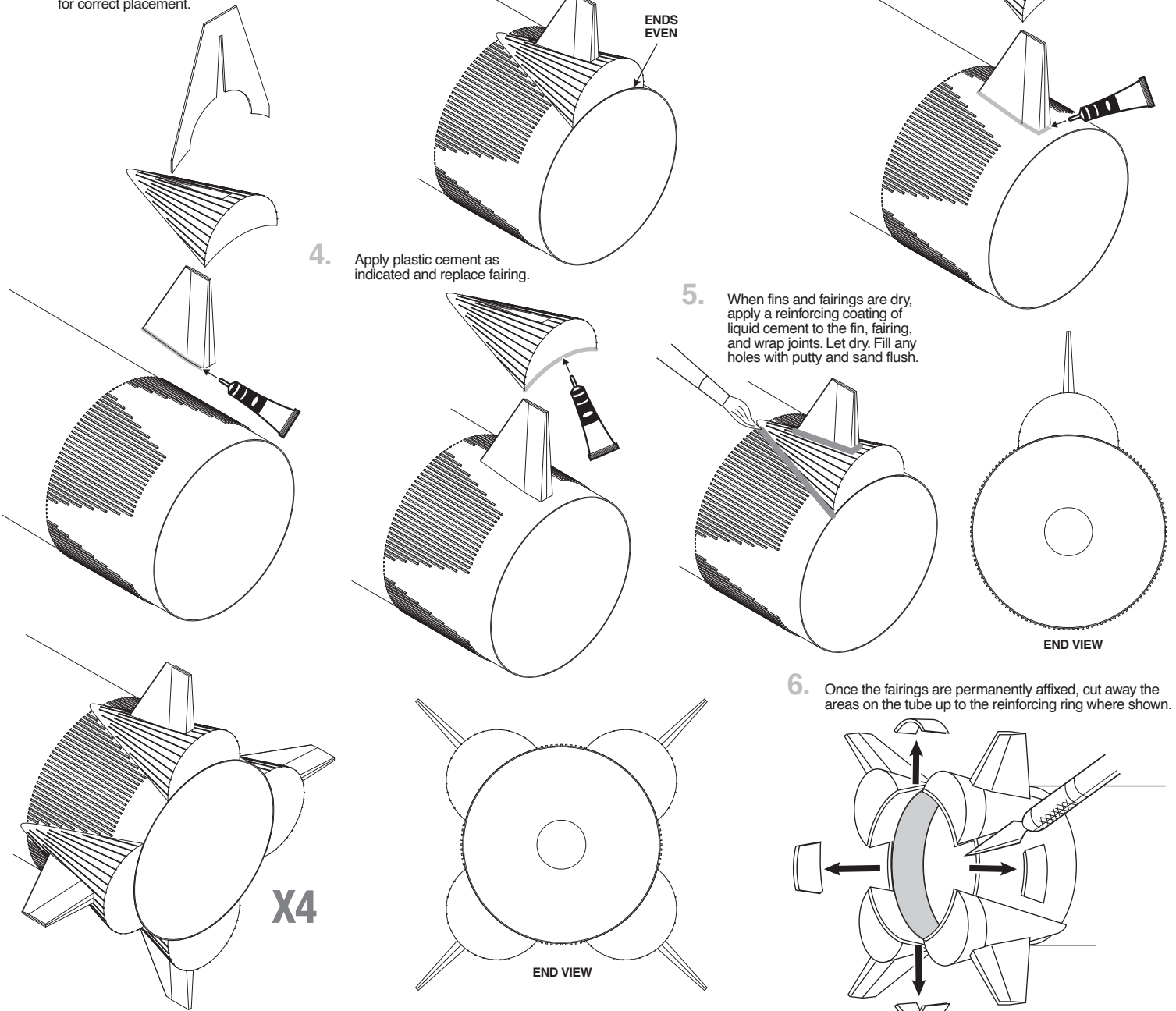

## ATTACH PLASTIC TUNNELS

1. Mark and cut the half round tunnels to continue between the 1st stage wrap and intertank wrap (both sides), between the intertank and second stage (both sides), and between the second stage and upper 2nd stage (one side), then use plastic cement to apply to body tube.

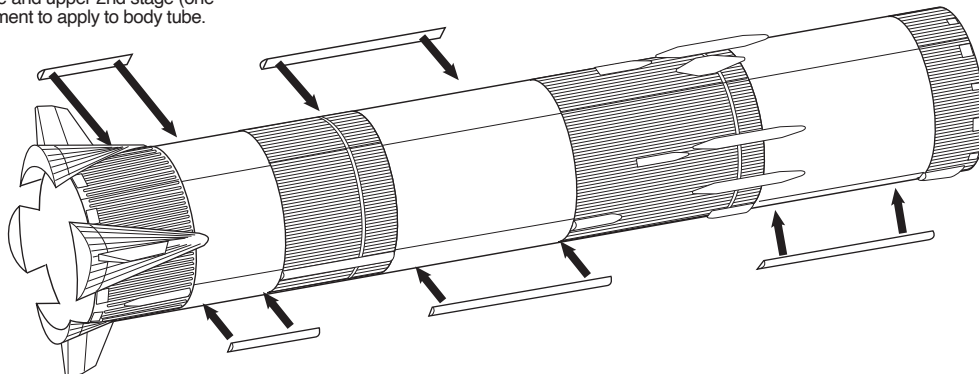

## ASSEMBLE TOWER

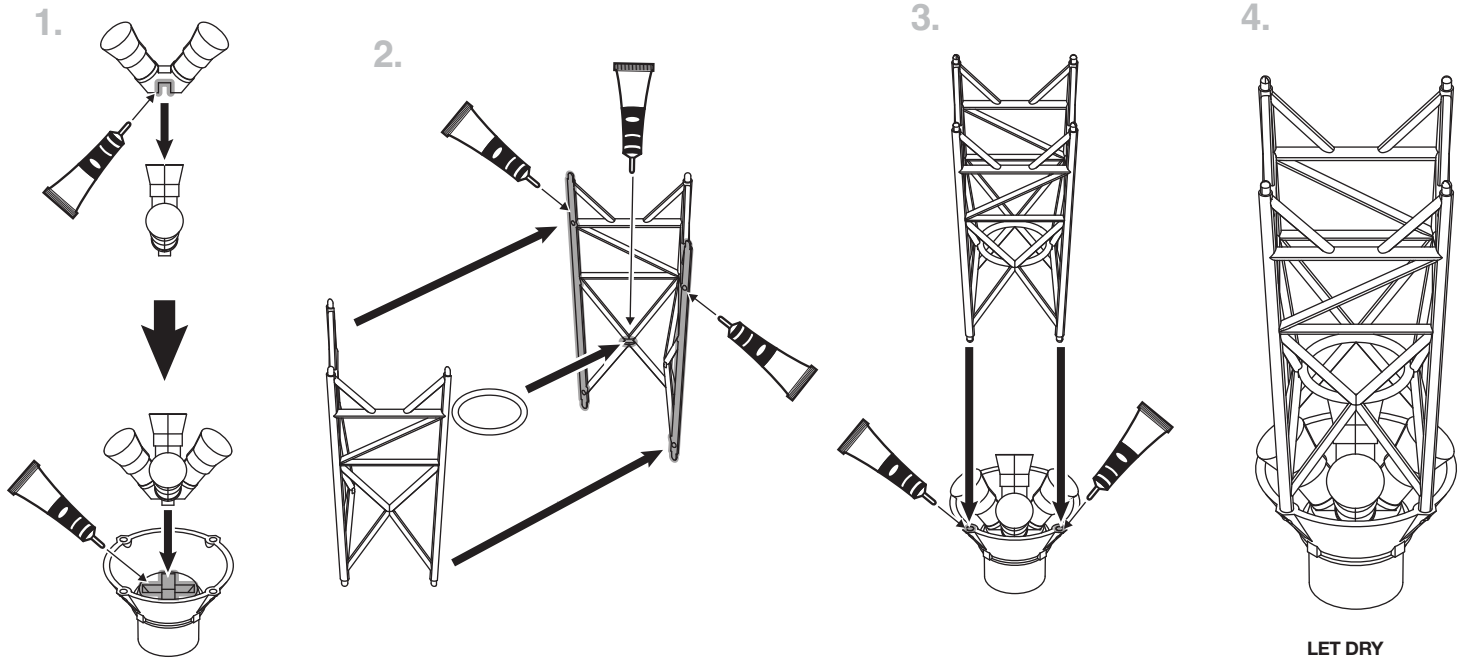

## ASSEMBLE CAPSULE

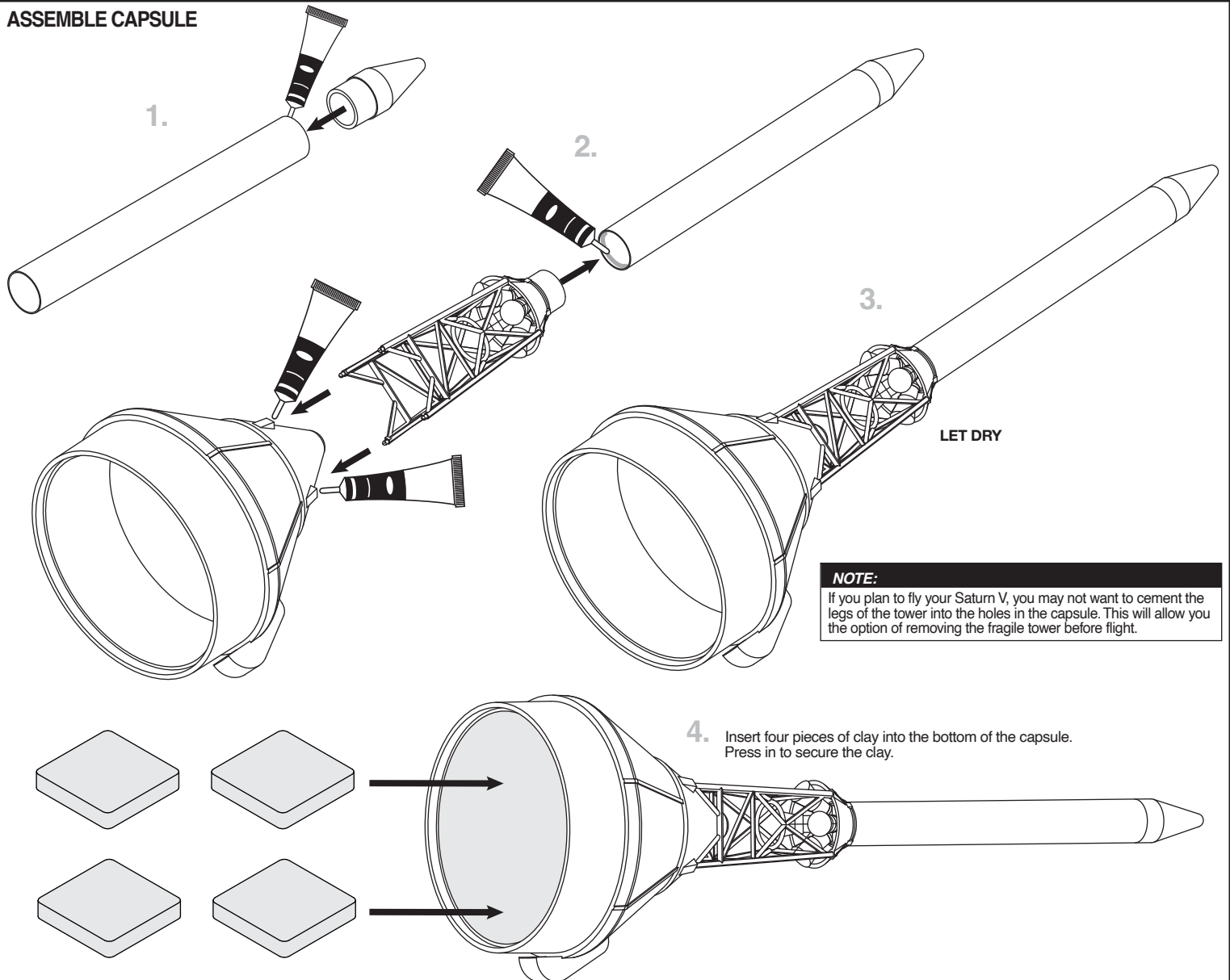

# INSTALL WIRE ANCHOR & TEST FIT NOSE CONE ASSEMBLY

1. Cut template out from template sheet.

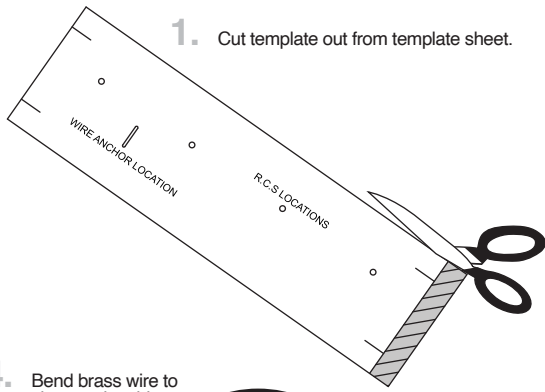

2.

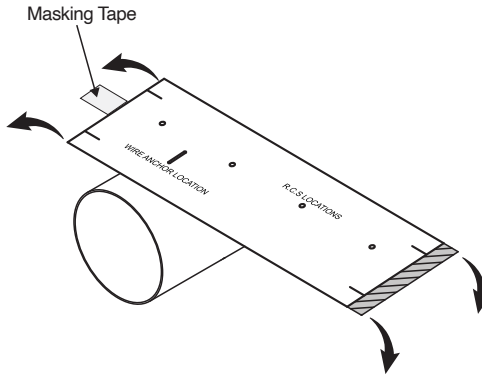

3. Rotate back and forth to create hole.

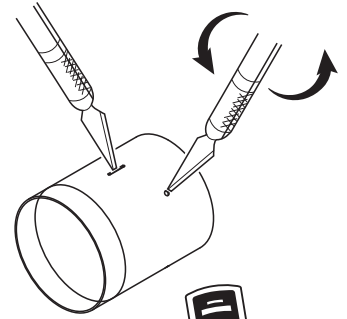

4. Bend brass wire to shape using this template.

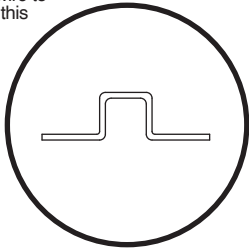

5.

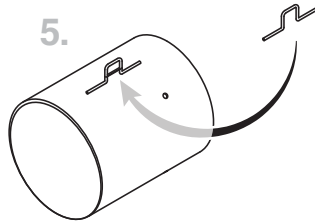

6.

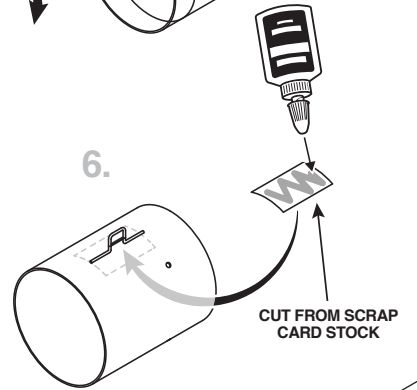

**NOTE:**  
Do not glue at this time. Only test fit. Final assembly will be after painting and checking center of gravity.

8. Insert four pieces of clay into the bottom of the capsule. Press in to secure the clay.

7.

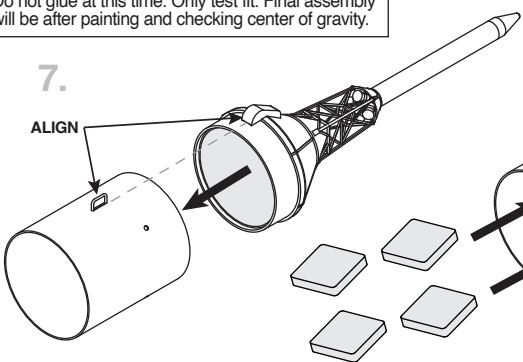

9.

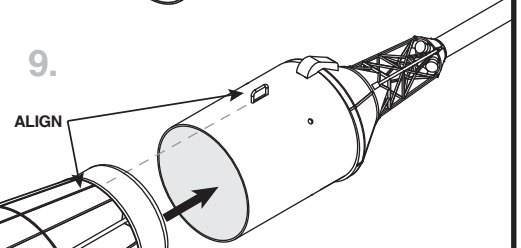

10.

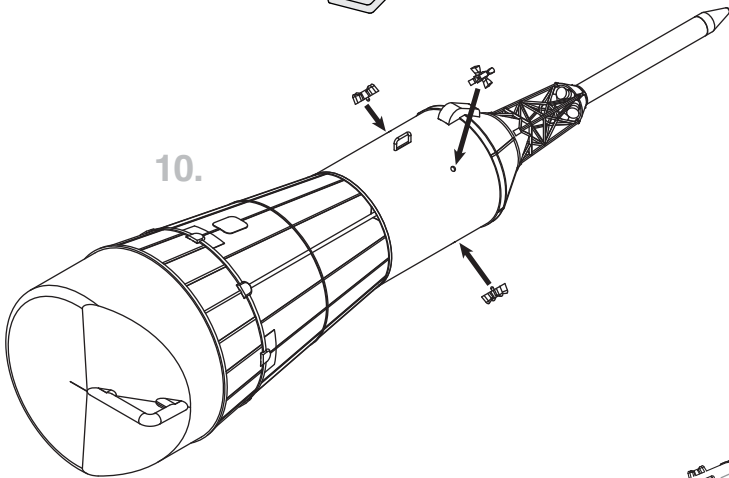

11.

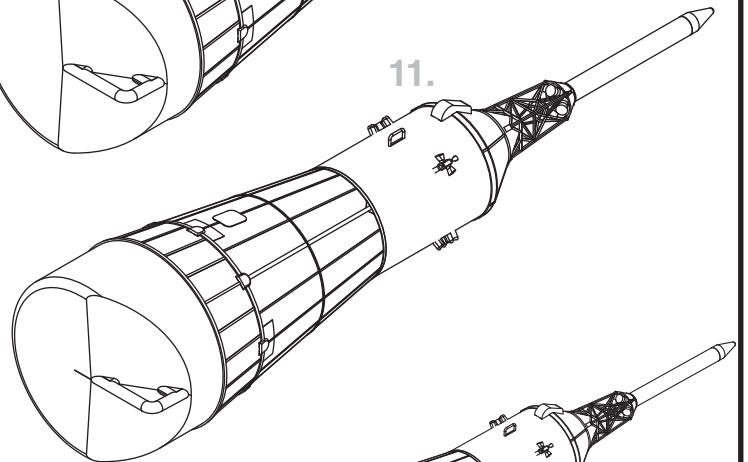

12.

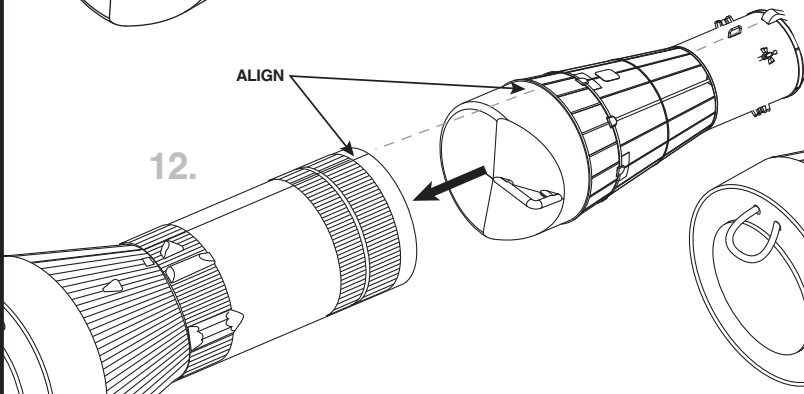

13.

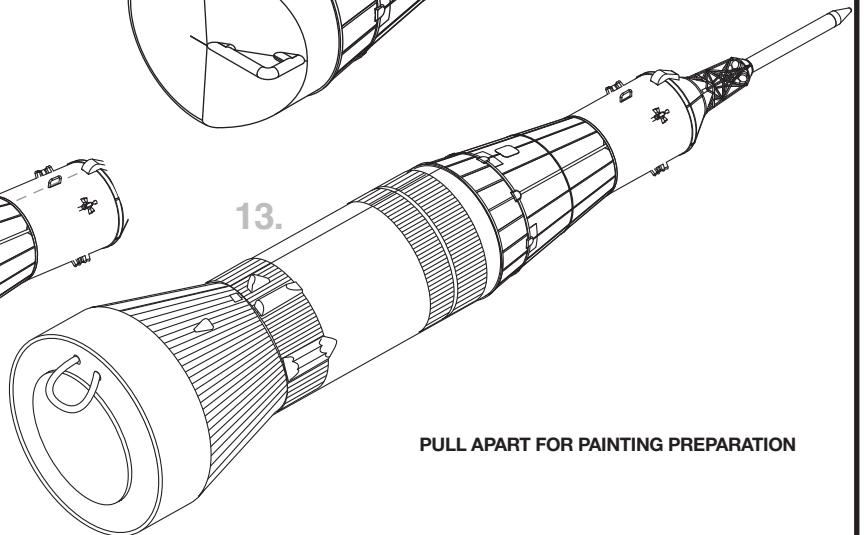

PULL APART FOR PAINTING PREPARATION

## INSTALL LAUNCH LUGS

### NOTE:

If you do not intend to fly your Saturn V, you may want to skip this step as launch lugs are only necessary on a flight model.

1. Use plastic cement to glue the launch lugs over the alignment line on the main body tube  $1/4"$  (6 mm) below the second stage wrap and just above the first stage wrap as indicated. Let dry.

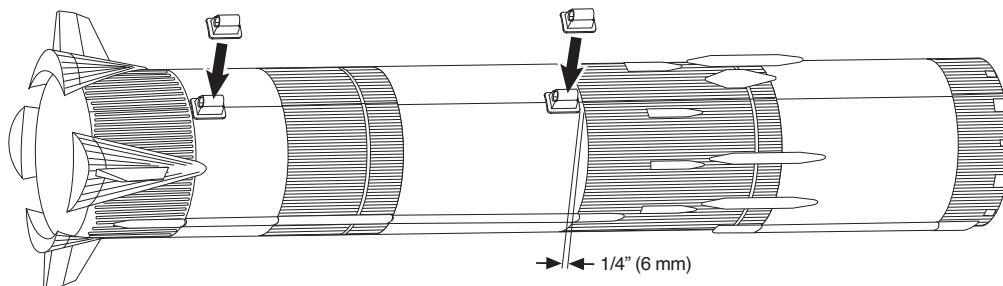

## INSTALL SHOCK CORD MOUNTS

1. Test fit the separate sections of the body together, and sand as necessary to achieve a good fit.
2. Cut out the two shock cord mounts on card 083591. Fold.
3. Lay shock cord onto shock cord mount at an angle as shown and apply glue to section two. Fold section 1 over.
4. Apply glue to section 3. Fold forward again. Clamp firmly until glue sets. Repeat for the other shock cord and mount.

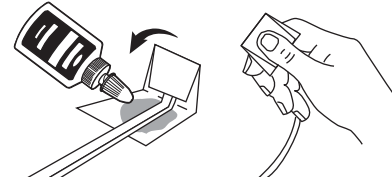
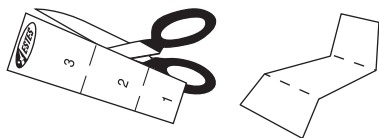

5. Apply glue to each mount and apply mounts to opposite sides of the main body tube at least  $2"$  (5.1 cm) down.

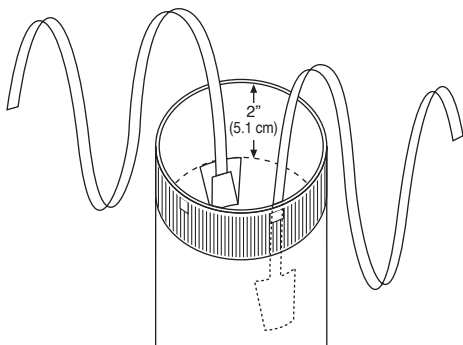

6. Tie a double knot at the free end of each shock cord.

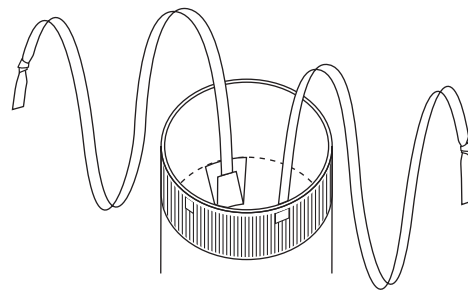

## PREPARE RECOVERY SYSTEM

1. Build all three parachutes according to the instructions printed on the parachute borders.
2. Form a loop in the shroud lines of one of the  $24"$  (61 cm) parachutes and lay a mounted shock cord over loop.
3. Pass parachute through loop and pull tight. Repeat with the other  $24"$  (61 cm) parachute and mounted shock cord.

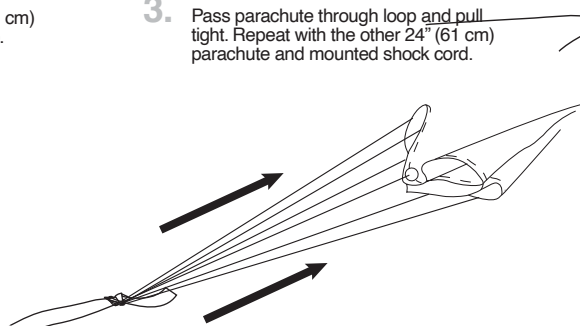
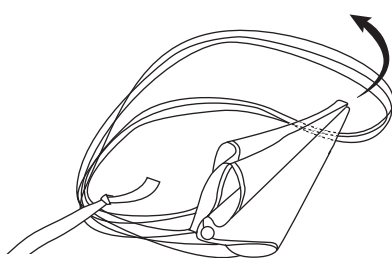
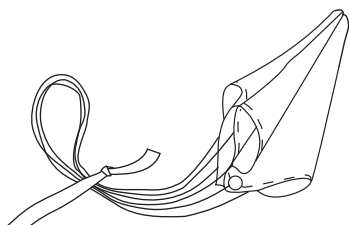

## PREPARE THIRD STAGE RECOVERY SYSTEM

1. Form a loop with the shroud lines on the  $18"$  (46 cm) parachute, and tie the remaining shock cord to the loop with a double knot.
2. Tie the free end of the shock cord to the loop at the rear of the third stage.
3. Measure a  $13"$  (33 cm) piece from the remaining aramid cord and tie one end to the snap swivel.

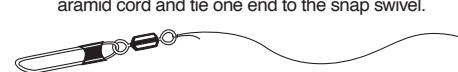
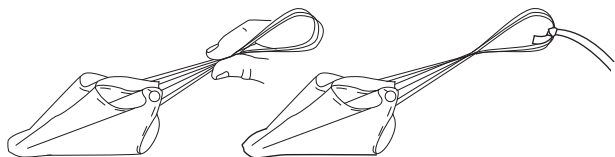

4. Tie the other end of the line to the shock cord  $15"$  (38 cm) from the rear of the third stage, then knot the shock cord over the line.

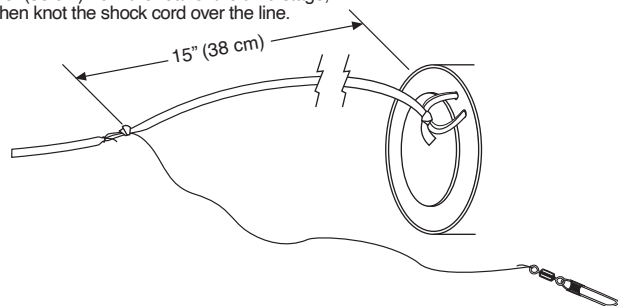

5. Snap the front of the snap swivel onto the brass anchor at the top of the L.E.M. (The snap swivel allows you to detach this portion of the recovery system and pack into the body tube for display.) Unhook for painting.

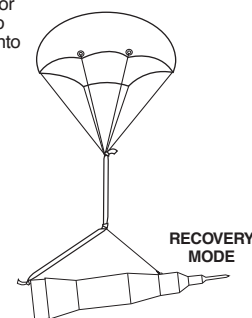
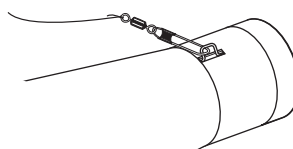

# MASK MODEL FOR PAINTING

1. Cut template out from template sheet.

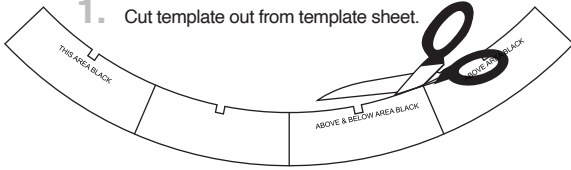

**NOTE:**

Use the model views on next spread for correct template placement taking into account the areas that are colored black and white.

2. Use masking tape to secure template in place.

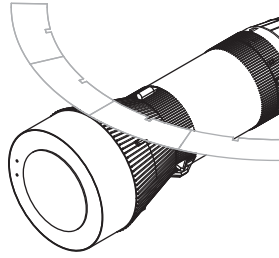

3. Make pencil marks around the top of the template and at each line on the template. Extend lines forward and back.

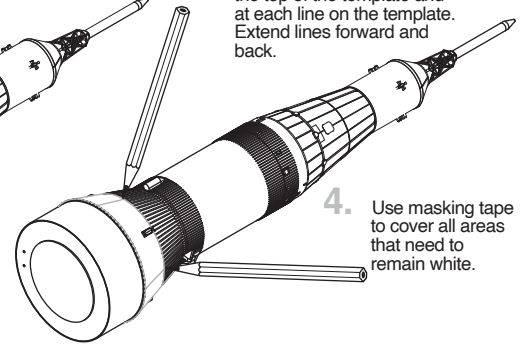

4. Use masking tape to cover all areas that need to remain white.

5. Cut the perimeter of the template with scissors. Cut out the inner areas marked with gray with a sharp hobby knife.

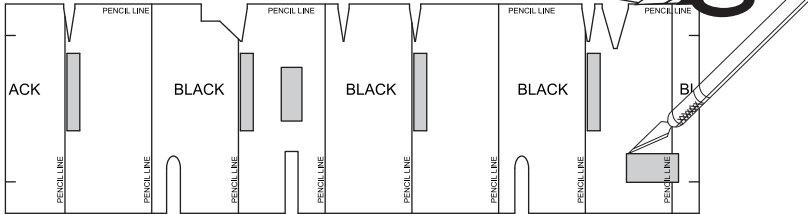

6. Align mask with the features on the second stage wrap. Wrap mask around the tube and secure in place with tape.

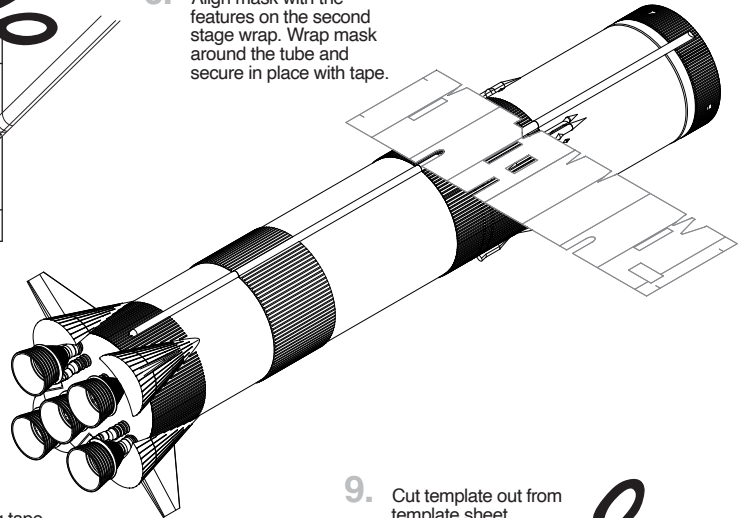

7. Make a pencil mark on both ends of the template on every line that says "PENCIL LINE". Extend lines between marks.

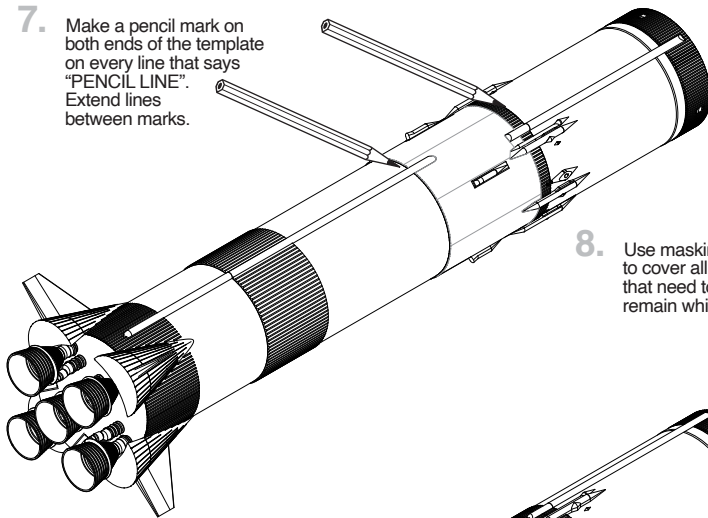

8. Use masking tape to cover all areas that need to remain white.

9. Cut template out from template sheet.

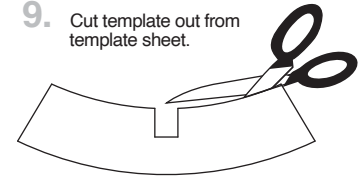

10. Wrap mask around fairing. Secure in place with tape.

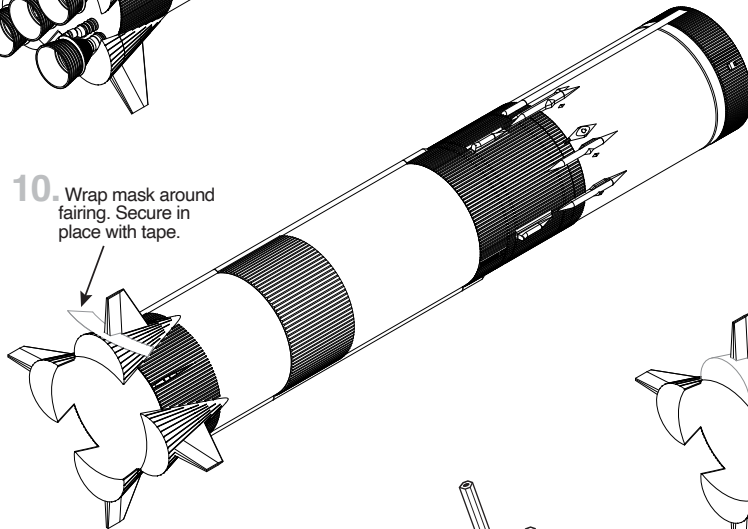

11. Make a pencil mark along the top of the template.

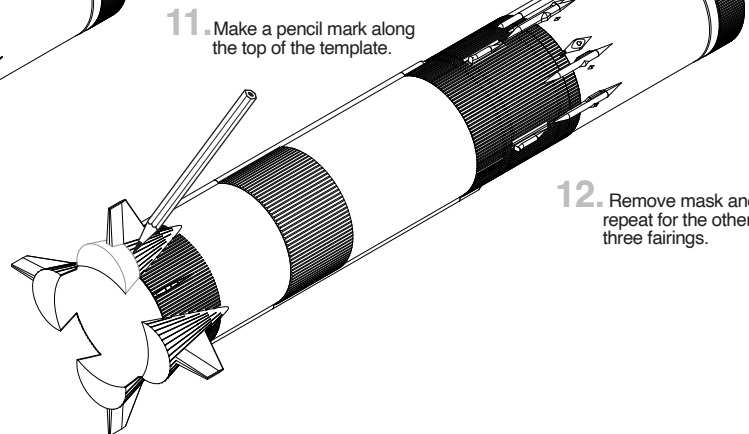

12. Remove mask and repeat for the other three fairings.

13. Make a pencil mark at the top of the fairings. Make another pencil mark above the blow molded feature between the fairings.

14. Extend those pencil marks forward.

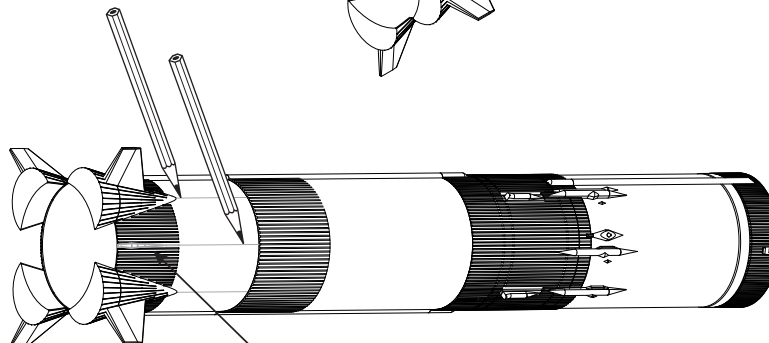

BLOW MOLDED FEATURE

15. Use masking tape to cover all areas that need to remain white or silver.

## PAINT ROCKET

Before painting, check that all the grain on wooden parts is filled, that all parts are firmly attached, and that any small gaps have been filled using putty or glue. If you did not fill the spirals in the body tubes earlier, do so now. Spray adhesive can be removed with a tissue dipped in enamel thinner (use sparingly!), and wood glue or CA can be removed using a fine grain sandpaper. If you do not wish to mask off the model, you may spray the entire model white, then use bottle paint for the black and silver (or gunmetal) areas. Again, **DO NOT USE LACQUER BASED PAINTS**. They will attack the plastic parts of your Saturn V. If you have any doubt about the paints you wish to use, use a piece of scrap plastic as a test surface. Follow the instructions in step 25 to pack your parachutes before painting.

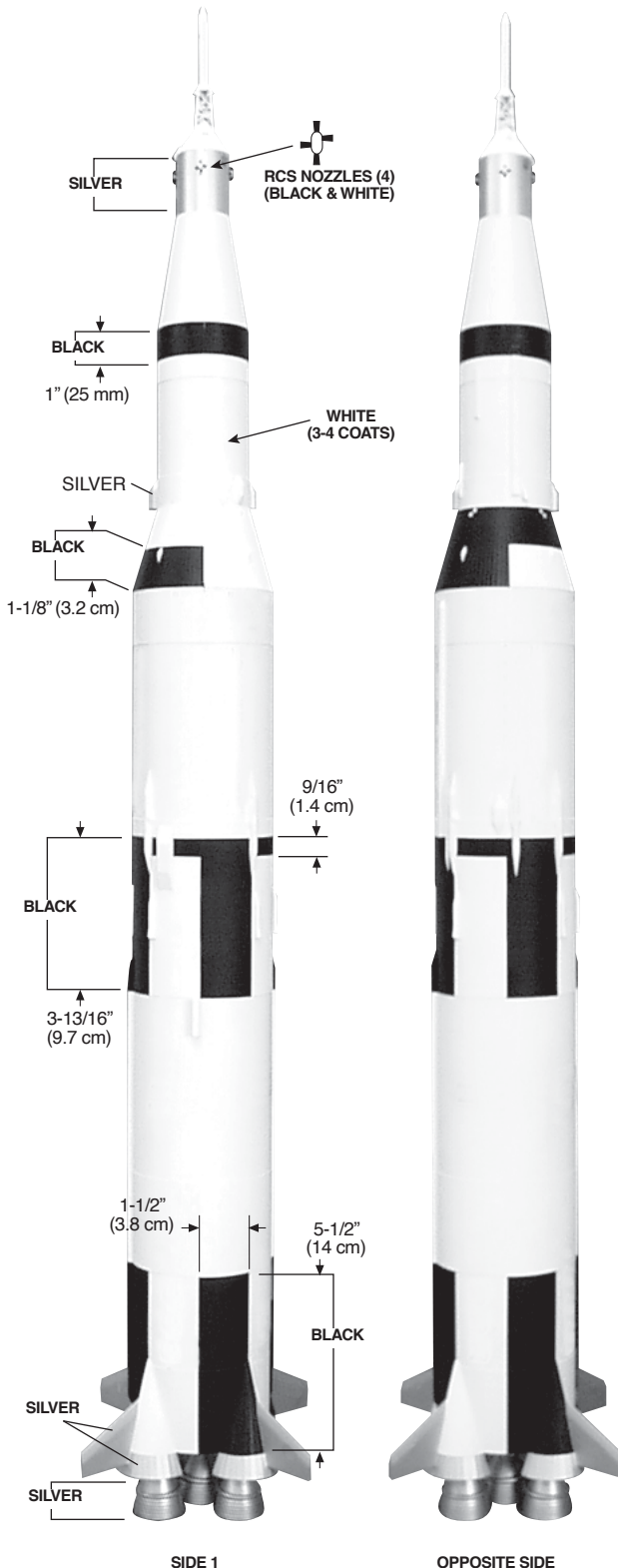

### CAUTION:

For safe handling of spray paint, see manufacturer's warnings and follow instructions for use.

1. Remove the display nozzle assembly and paint the visible (rear) section silver or gunmetal gray. Spray a coat of good quality sandable primer (suitable for plastics and paper) over the entire surface of the model. Let dry, then examine the model for flaws. Correct as necessary. Prime and sand the model until you are satisfied with the finish.
2. Spray the entire model with 3-4 coats of flat white and let dry at least 24 hours. While paint is drying, carefully study the diagram for the location of the black, gunmetal gray, and silver areas. Careful masking is required to obtain the correct paint pattern.

**MASKING NOTES:** Special automotive masking or pin-striping tape is preferred for use due to the low tack and flexibility of the material. If using ordinary masking tape, press it against a plate of glass to remove some of the adhesive before applying to the model. When masking surfaces that have a compound curve, use narrow tape or cut your tape into narrow strips so that it will stretch and follow the curve. Carefully mask all paint separation points, then cover the large exposed areas with paper or plastic (the less tape touching the model the better) making sure the edges are taped down to prevent overspray. In all cases, mask off the coupler shoulder to prevent paint from building up on the mating surfaces. Spray another coat of white to seal the masked area and minimize overspray and let dry. Once dry, spray the color onto the masked area. As soon as the paint is dry to the touch, carefully remove the masking.

3. Mask off the fins and engine fairings and paint them silver or gun metal gray (be consistent with the color you painted the display nozzle assembly.)
4. Cut out the masking guide for the Service Module (SM), and paint the exposed SM surfaces silver.
5. Paint the plastic RCS nozzles as shown.
6. Use the diagram to mask and paint the roll pattern.
7. Once the roll pattern is complete and dry, use CA to apply the RCS nozzles.
8. Place the capsule on top of the L.E.M. assembly, rotate until plastic tab is aligned with seam and hook, make an alignment mark, and apply with CA.

## APPLY DECALS

1. Cut out one decal at a time from the sheet. Soak the decals, one at a time, in warm water for 15-30 seconds until decal will slide easily from the backing paper. Transfer the decal to the model, and gently blot away excess water and air bubbles with a soft cloth.

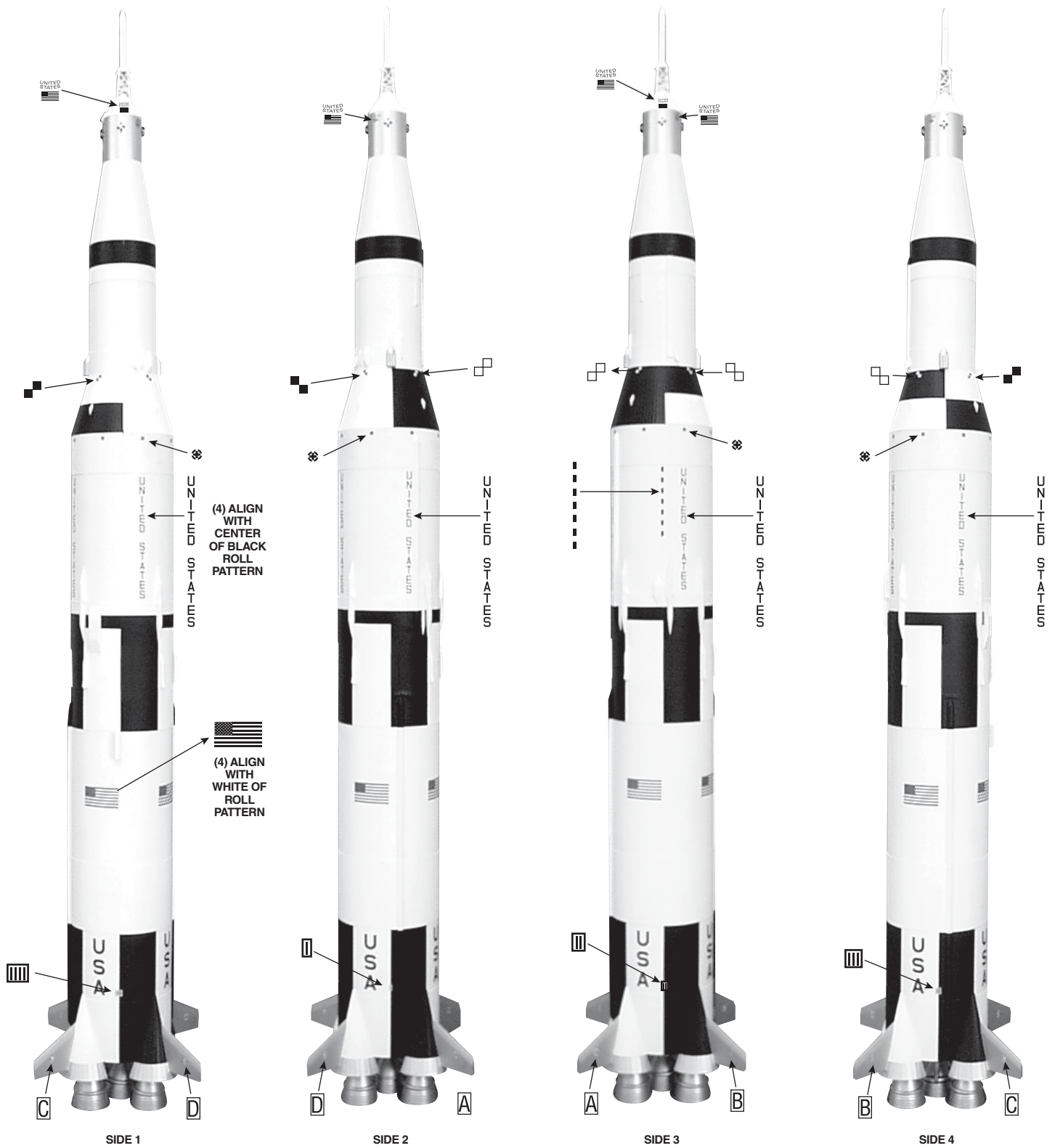

2. The "USA", American flag, and "United States" decals are centered vertically within the paint patterns, and horizontally between the body wraps. Measure and place light tic marks to help you properly orient decals. Raised squares on the second stage and reduction wraps provide locations for the camera and target decals.
3. Finish by painting the entire model with a flat clear coat.

## PREPARE FLIGHT RECOVERY

1. Crumple and place four squares of recovery wadding into the front of engine mount tube.
2. Lay six squares of wadding flat in the bottom of parachute compartment.

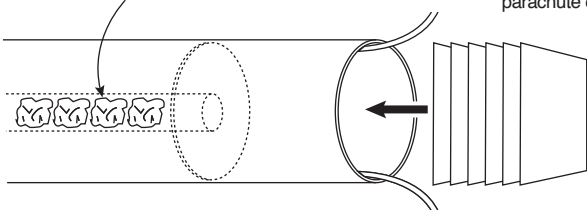

3. Spike, fold, and roll the 24" (61 cm) parachutes and insert into parachute compartment.

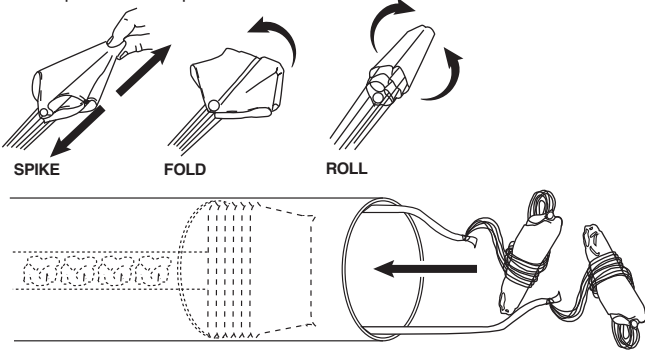

4. Lay two flat squares of wadding on top of parachutes.

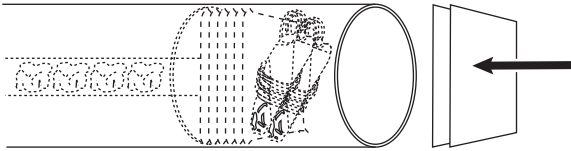

5. Fold and roll the forward section parachute, and lay parachute on the wadding in the middle of the parachute compartment. Insert the forward section into the main body tube, and twist back and forth to make sure the sections do not bind. Sand if necessary.

**NOTE:**  
If needed, sand inside edge of body tube to smooth out any burrs before inserting nose cone.

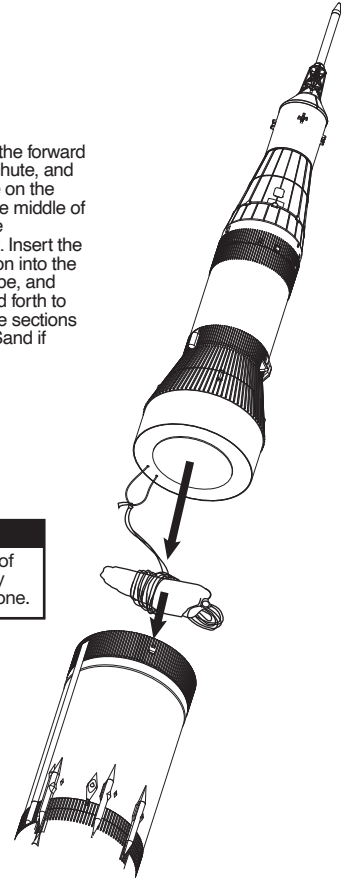

## PREPARE ENGINE RETENTION

1. Wrap 6 to 8 layers of masking tape over nozzle end of motor. Overlap end of engine by 1/4 inch (6 mm).
2. Trim off excess tape.

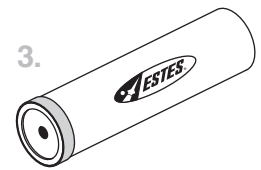
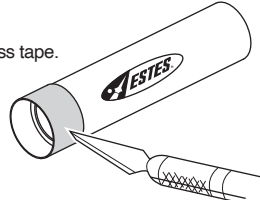
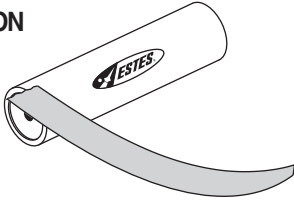

## PREPARE ENGINE

1. ENGINE

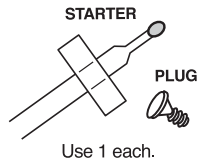
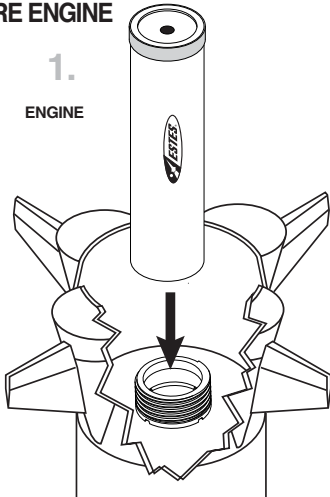

Use 1 each.

**TIP MUST TOUCH PROPELLANT!**

- 2.

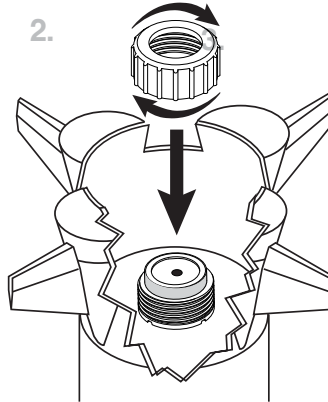

- 3.

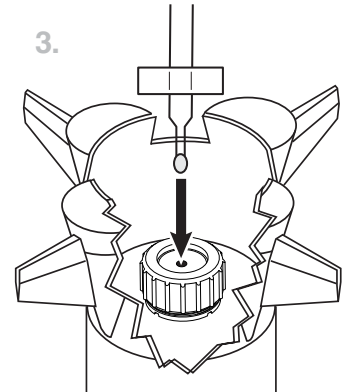

- 4.

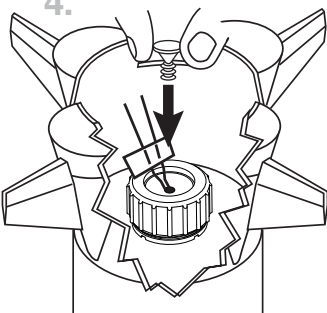

- 5.

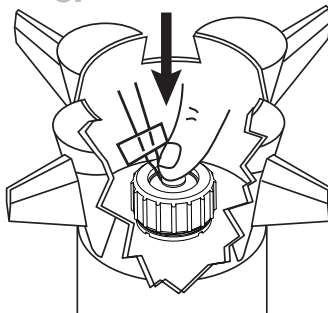

- 6.

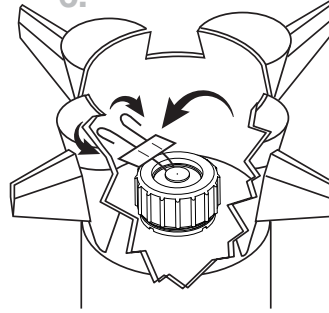

**WARNING: FLAMMABLE**

To avoid serious injury, read instructions & NAR Safety Code included with engines. **PREPARE YOUR ENGINE ONLY WHEN YOU ARE OUTSIDE AT THE LAUNCH SITE PREPARING TO LAUNCH.** If you do not use your prepared engine, remove the starter before storing your engine.

CHECK CENTER OF GRAVITY FOR STABLE FLIGHT AND FINAL ASSEMBLY

1.

Ready for flight with Engine Installed

**CAUTION:**  
Be sure that the center of gravity is in the correct location for a stable flight before first launch. Be sure to check the center of gravity with an engine installed before moving on to steps 2-5.

**NOTE:**  
Add more weight to the nose cone until you get the correct center of gravity.

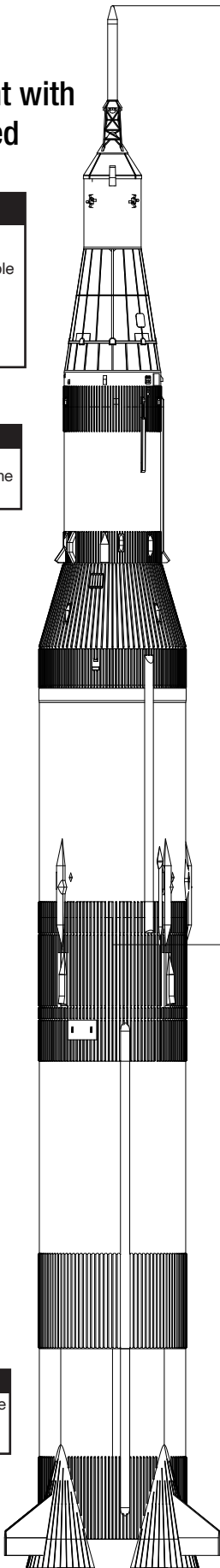

25.25 in.  
(64.2 cm)



**NOTE:**  
Be sure display nozzles are not attached when checking center of gravity.

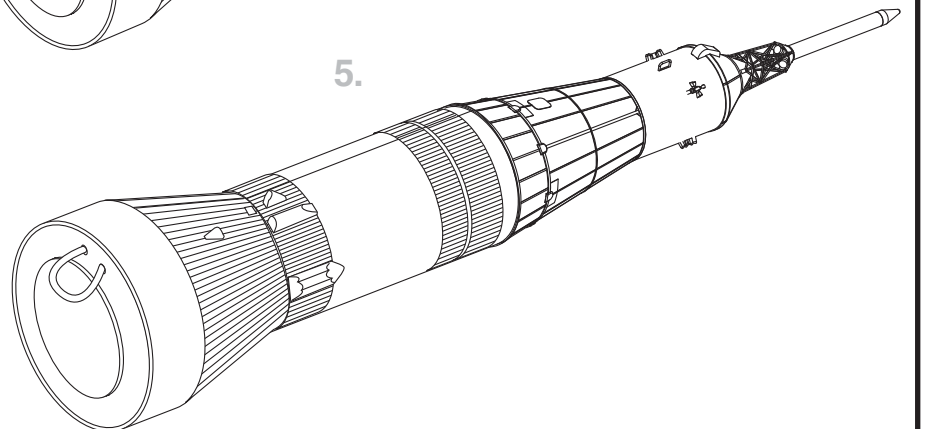
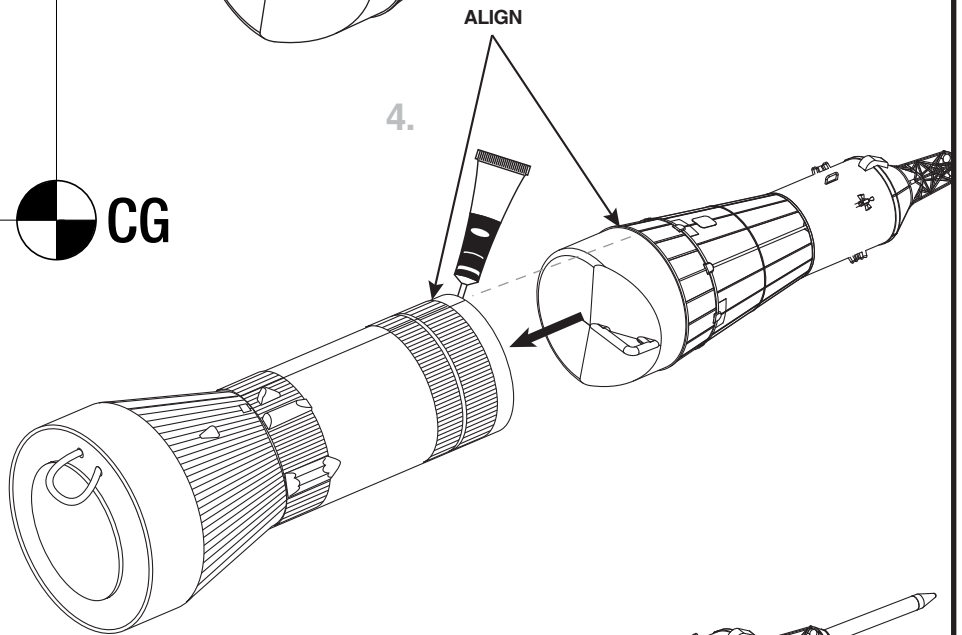
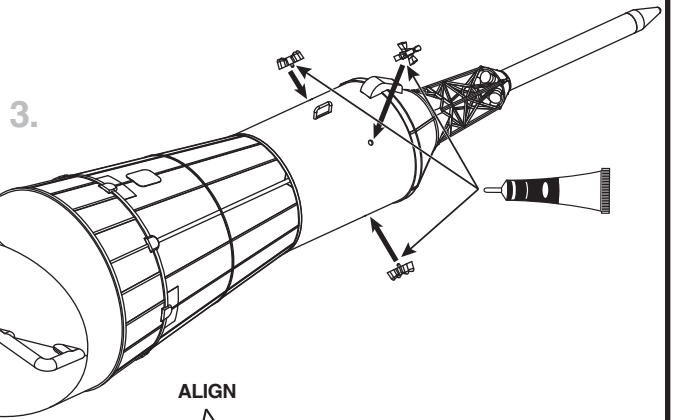
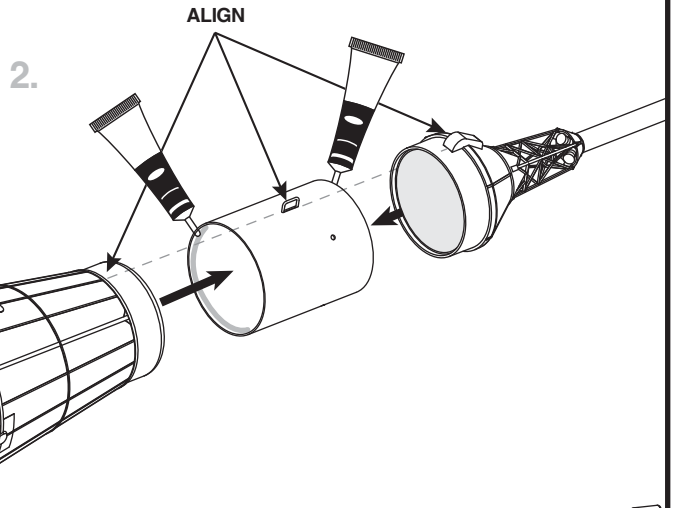

# COUNTDOWN AND LAUNCH

**NOTE:**  
Key always out until final countdown!

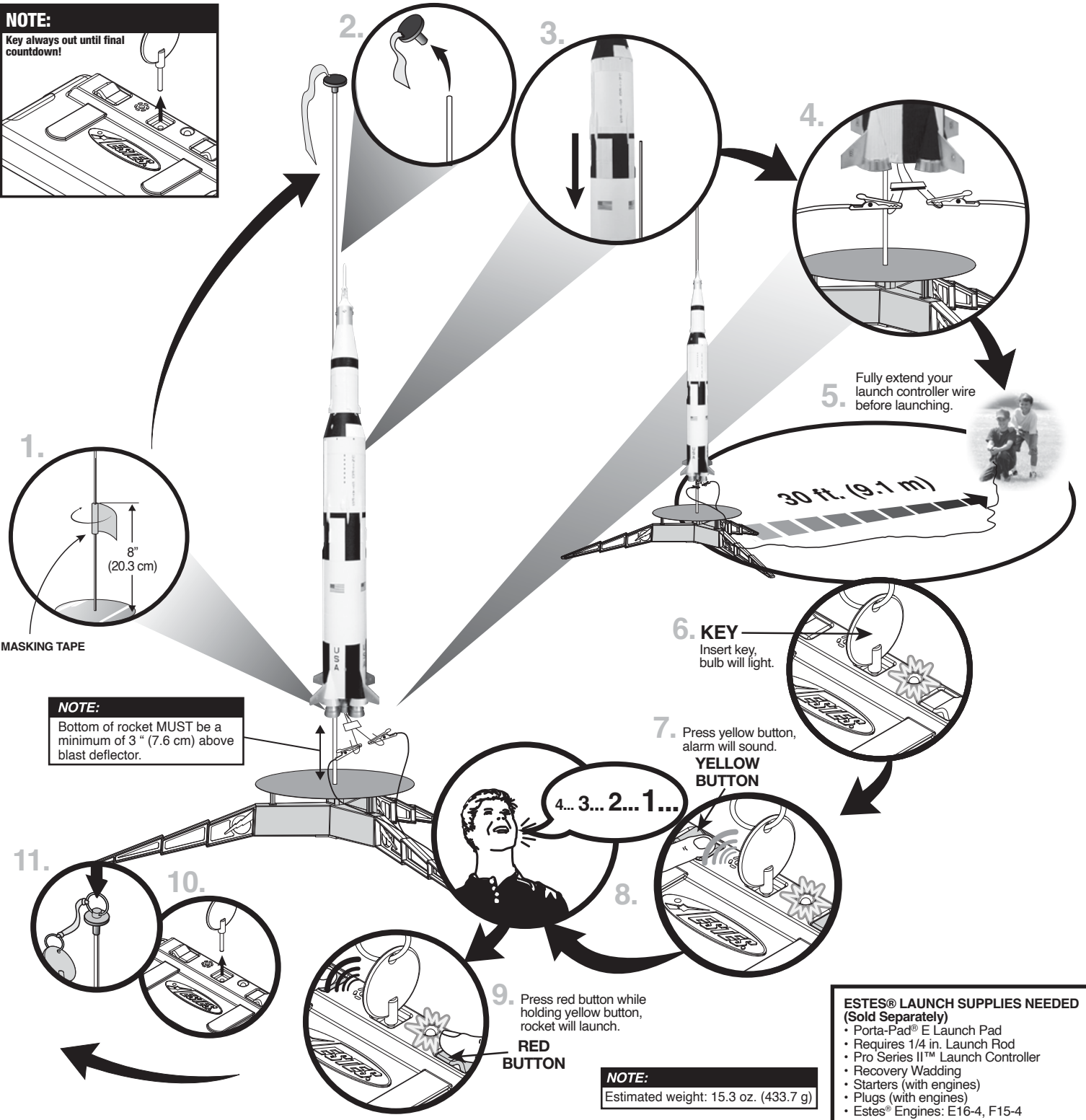

**1.** MASKING TAPE

8" (20.3 cm)

**NOTE:**  
Bottom of rocket MUST be a minimum of 3" (7.6 cm) above blast deflector.

**NOTE:**  
Estimated weight: 15.3 oz. (433.7 g)

- ESTES® LAUNCH SUPPLIES NEEDED (Sold Separately)**
- Porta-Pad® E Launch Pad
  - Requires 1/4 in. Launch Rod
  - Pro Series II™ Launch Controller
  - Recovery Wadding
  - Starters (with engines)
  - Plugs (with engines)
  - Estes® Engines: E16-4, F15-4

## PRECAUTIONS

**NAR SAFETY CODE**

**NO DRY GRASS OR WEEDS**

**PRE-LAUNCH CHECK** For safety, never launch a damaged rocket. Check the rocket's body, nose cone and fins. Also, check the engine mount, recovery system and launch lug(s). Repair any damage before launching the rocket.

**FLYING YOUR ROCKET** Choose a large field (500 ft [152 m] square) free of dry weeds and brown grass. The larger the launch area, the better your chance of recovering your rocket. Football fields and playgrounds are great. Launch only with little or no wind and good visibility. Always follow the National Association of Rocketry (NAR) SAFETY CODE.

**MISFIRES TAKE THE KEY OUT OF THE CONTROLLER. WAIT ONE MINUTE BEFORE GOING NEAR THE ROCKET.** Disconnect the micro-clips and remove the engine. Take the plug and starter out of the engine. A burned starter means the starter tip was not touching engine propellant. Install a new starter; be sure the tip is touching propellant inside the engine. Push the plug in place. Repeat steps under Countdown and Launch.