

Da Vinci Machines Series

Da Vinci

Armoured car

- Armoured combat vehicles designed by Leonardo da Vinci
- Operated by mechanical spring

ACADEMY

HOBBY MODEL KITS

18136



Leonardo da Vinci
(1452-1519)

Parts Locating Diagram

A

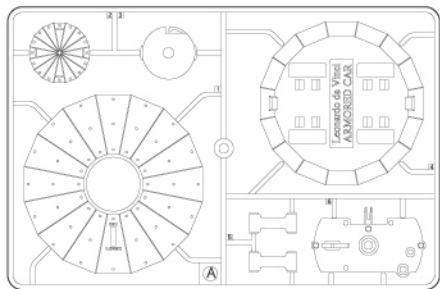

B

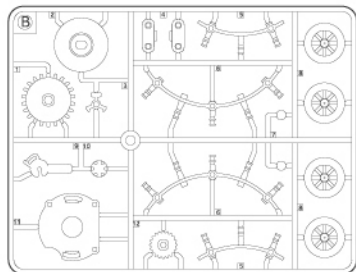

● Spare parts: B7X1

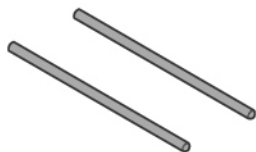

Shaft 2EA

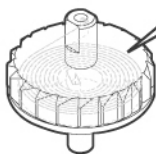

Spring Winding Unit

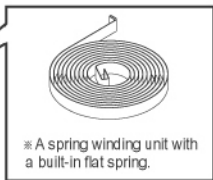

※ A spring winding unit with a built-in flat spring.

1

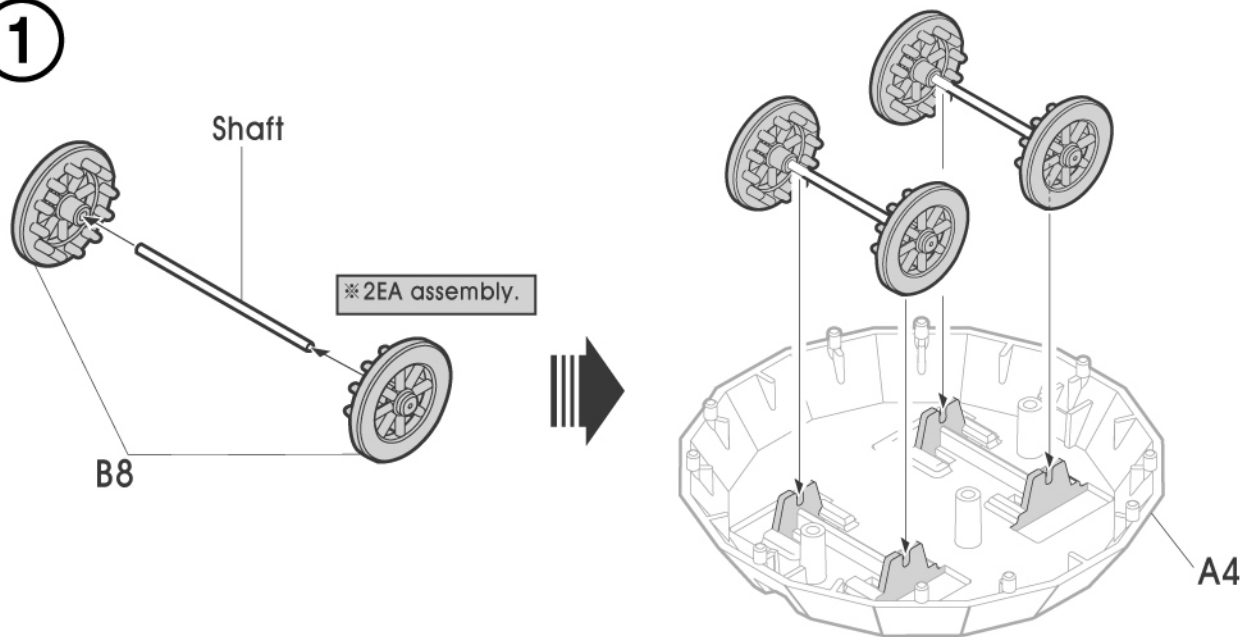

2

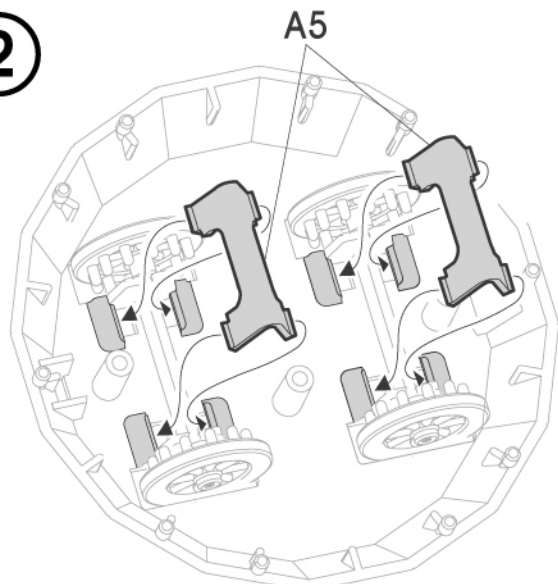

※ Align the pegs and holes, then push together.

3

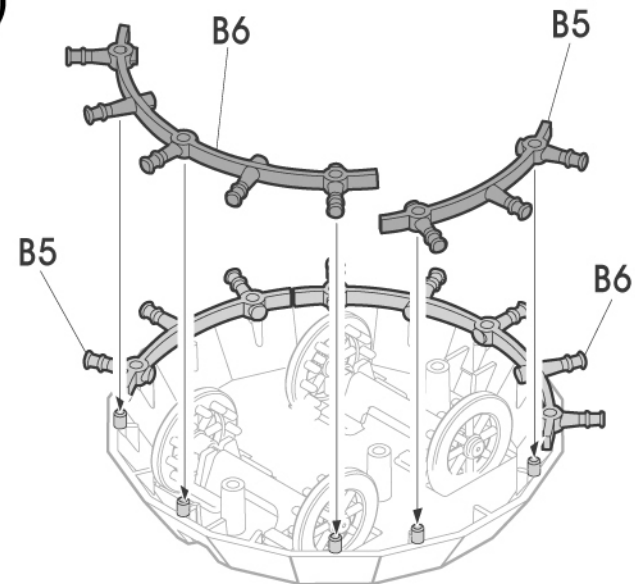

4

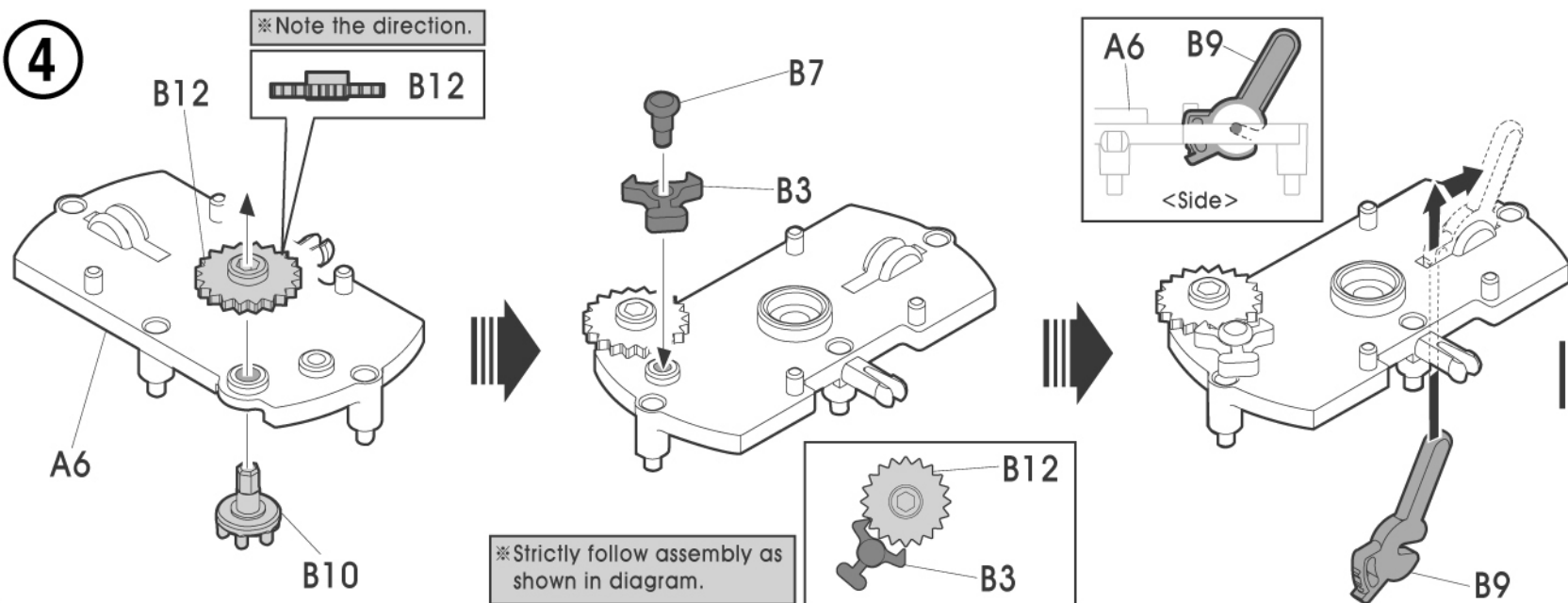

5

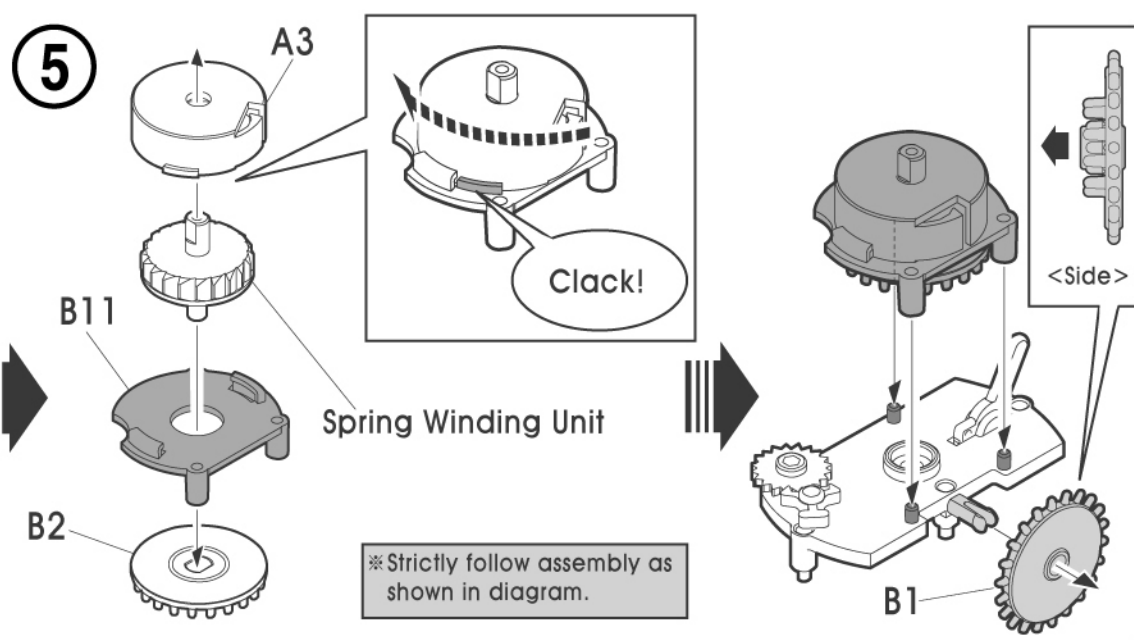

6

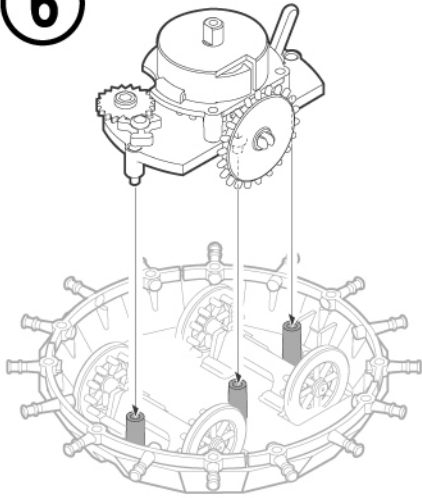

7

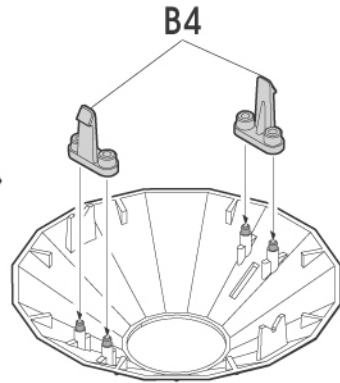

8

※Strictly follow the assembly order as shown by the numbers.

A2

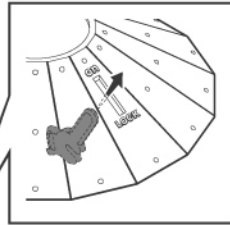

A1

1

※Align the pegs and holes, then push together.

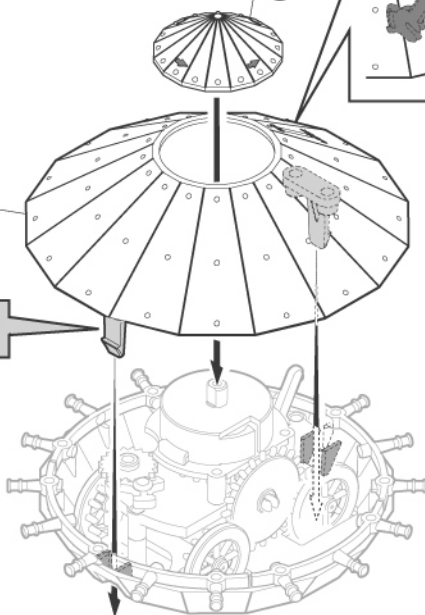

■Finished Model Views

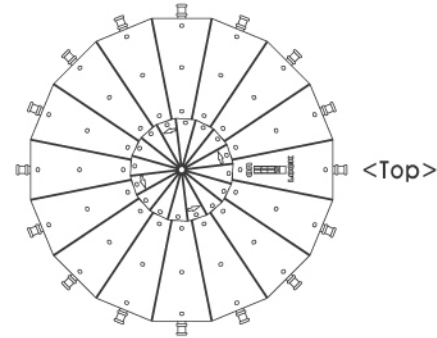

<Top>

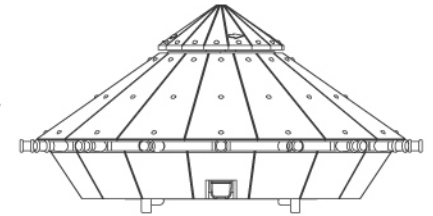

<Front>

■How to Operate

※Follow these 4 step in the order shown.

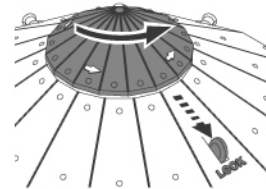

1 Put lever in the 'LOCK' position.

2 Wind in the direction of the arrows.

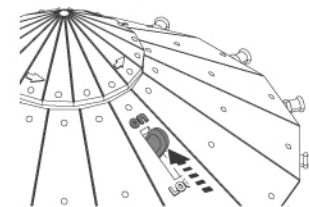

3 When Spring Winding Unit stops, it is fully wound. Do not force beyond this point.

4 Move lever to the "on" position.

Direction of Travel! ←

